



US 20150374249A1

(19) **United States**
(12) **Patent Application Publication**
Elliott et al.

(10) **Pub. No.: US 2015/0374249 A1**
(43) **Pub. Date: Dec. 31, 2015**

(54) **PERSONAL HEALTH DATA COLLECTION**

(52) **U.S. Cl.**

(71) Applicant: **LÉMAN MICRO DEVICES SA,**
Lausanne (CH)

CPC *A61B 5/02233* (2013.01); *A61B 5/0261*
(2013.01); *A61B 5/489* (2013.01); *A61B*
5/7405 (2013.01); *A61B 5/742* (2013.01);
A61B 5/6897 (2013.01); *A61B 5/6898*
(2013.01)

(72) Inventors: **Christopher Elliott,** St. Sulpice (CH);
Mark-Eric Jones, Cossonay-Ville (CH);
Mikhail Nagoga, Pully (CH); **Shady**
Gawad, Lonay (CH); **Gabriel Klein,**
Montpreveyres (CH)

(57) **ABSTRACT**

(21) Appl. No.: **14/767,444**

(22) PCT Filed: **Feb. 13, 2014**

(86) PCT No.: **PCT/IB2014/058969**

§ 371 (c)(1),

(2) Date: **Aug. 12, 2015**

This disclosure provides a personal hand-held monitor (PHHM) which comprises a signal acquisition device for acquiring signals which can be used to derive a measurement of a subject's blood pressure (BP), the signal acquisition device being integrated with a personal hand-held computing device (PHHCD). The signal acquisition device comprises a blood flow occlusion means adapted to be pressed against one side only of a body part or to have one side only of a body part pressed against it, a means for measuring the pressure applied by or to the body part, and a means for detecting the flow of blood through the body part in contact with the blood flow occlusion means. The blood flow occlusion means comprises at least part of an external surface of the PHHM and wherein the pressure is sensed by means of a flexible and essentially incompressible gel in which is immersed a pressure sensor. The pressure sensor is adapted to provide electrical signals to the processor of the PHHCD.

(30) **Foreign Application Priority Data**

Feb. 13, 2013 (GB) 1302548.1
Sep. 23, 2013 (GB) 1316914.9
Sep. 23, 2013 (GB) 1316915.6

Publication Classification

(51) **Int. Cl.**

A61B 5/022 (2006.01)
A61B 5/00 (2006.01)
A61B 5/026 (2006.01)

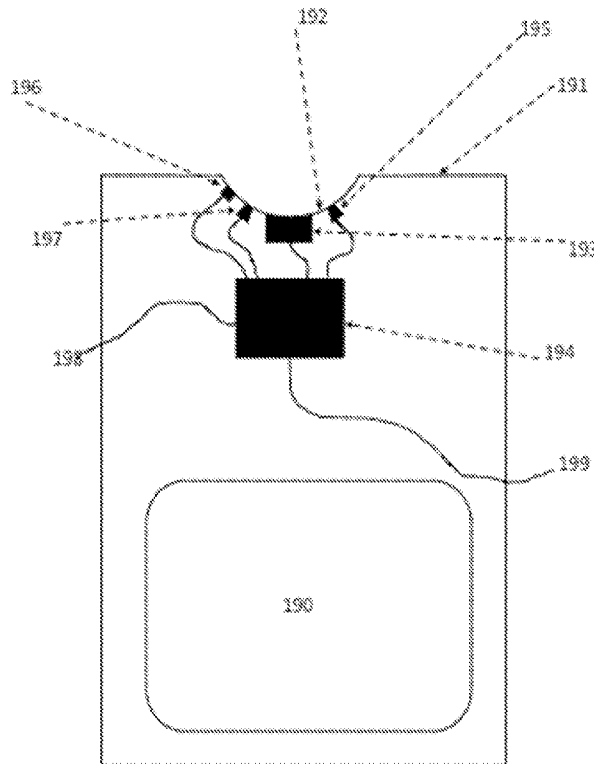

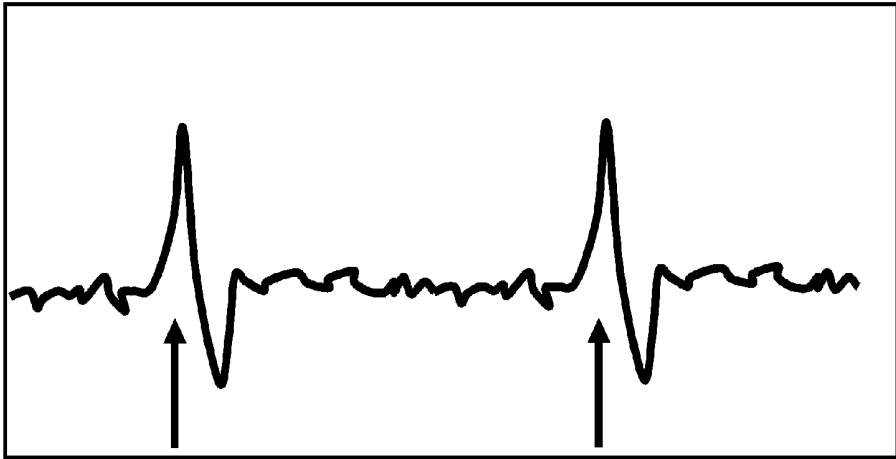

Figure 1: The amplified and filtered potential difference.

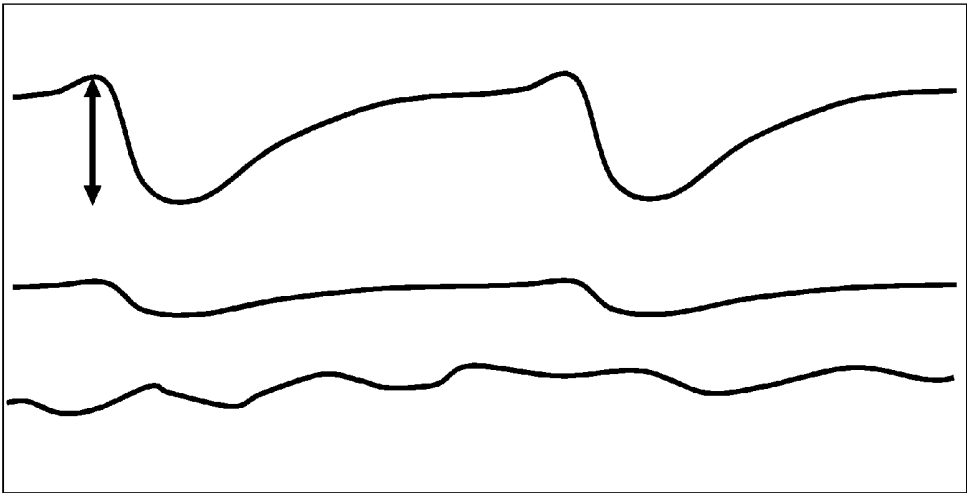

Figure 2: Schematic drawings of PPG signals

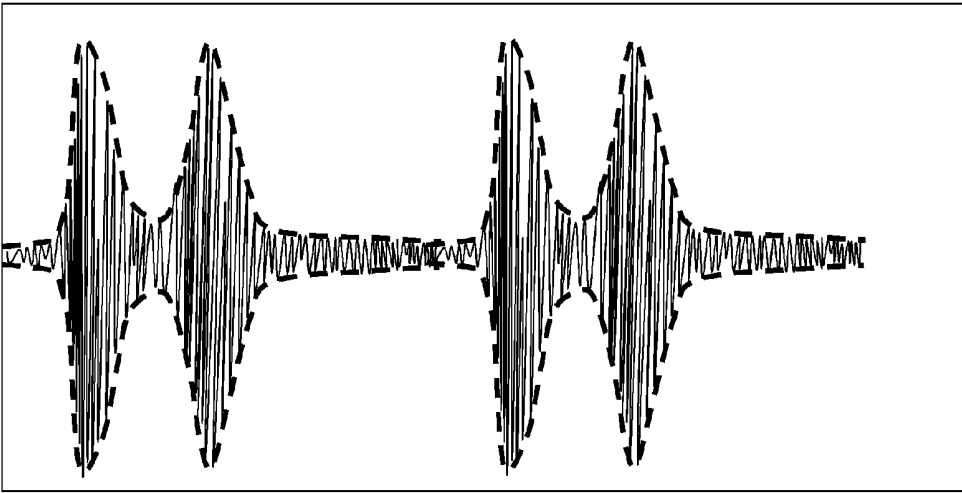

Figure 3: signal collected by the acoustic sensor

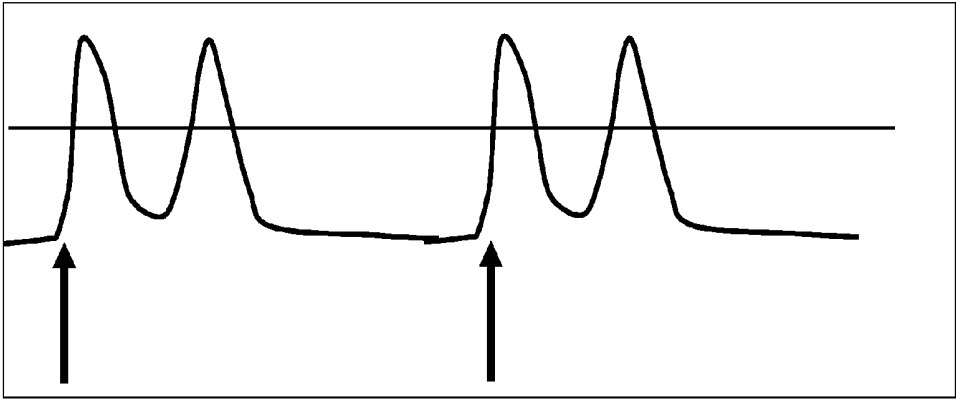

Figure 4: The acoustic envelope.

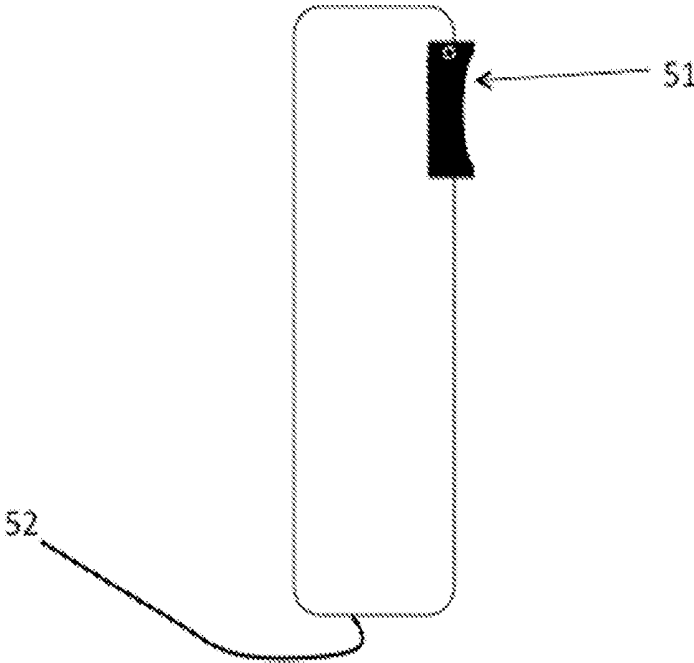

Figure 5

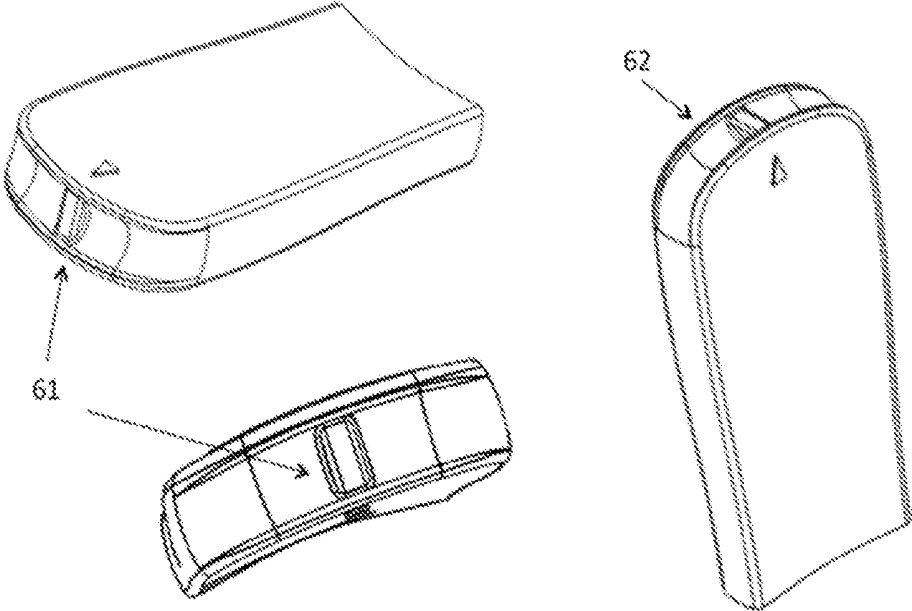

Figure 6

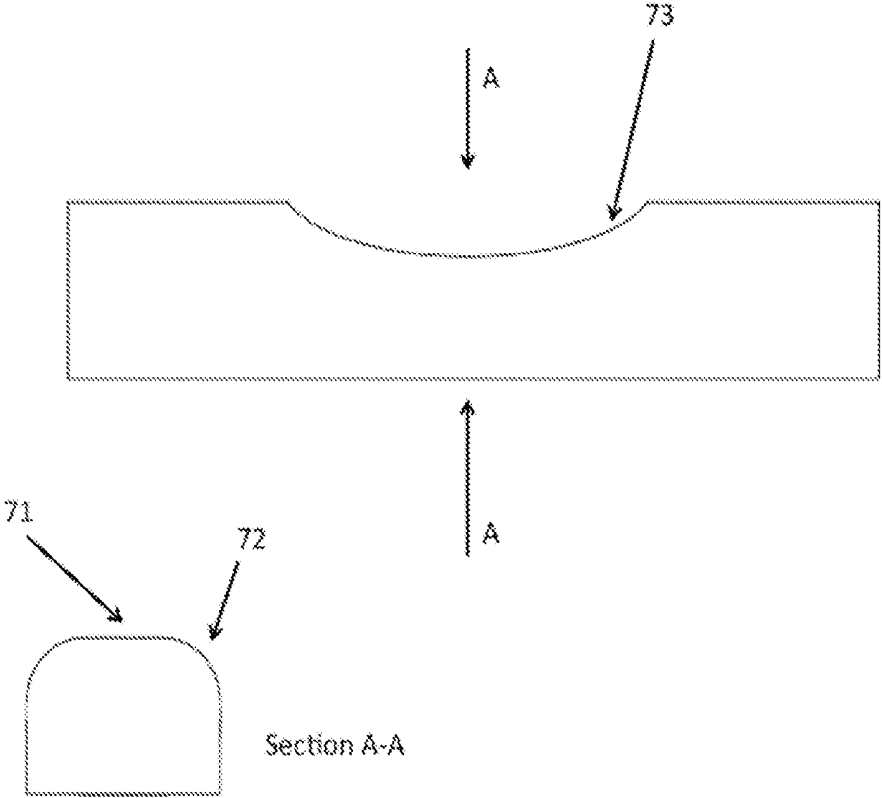

Figure 7

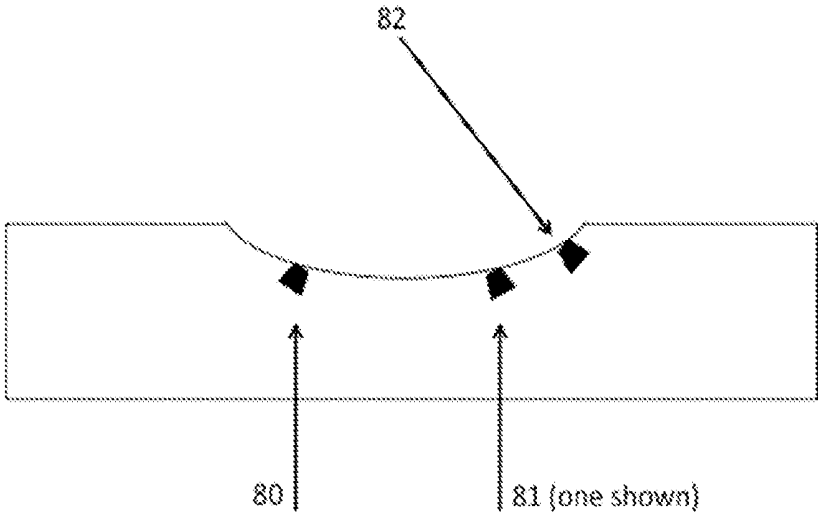

Figure 8

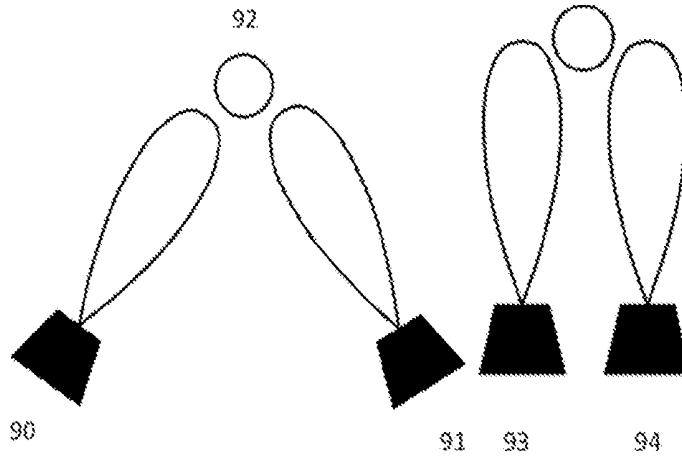

Figure 9a

Figure 9b

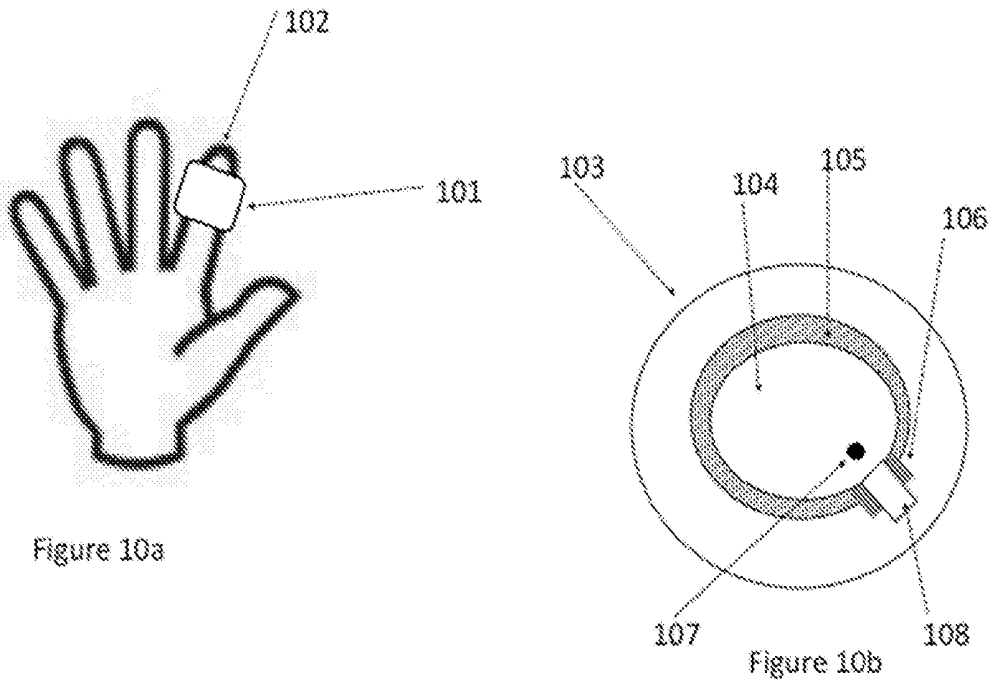

Figure 10a

Figure 10b

Figure 10

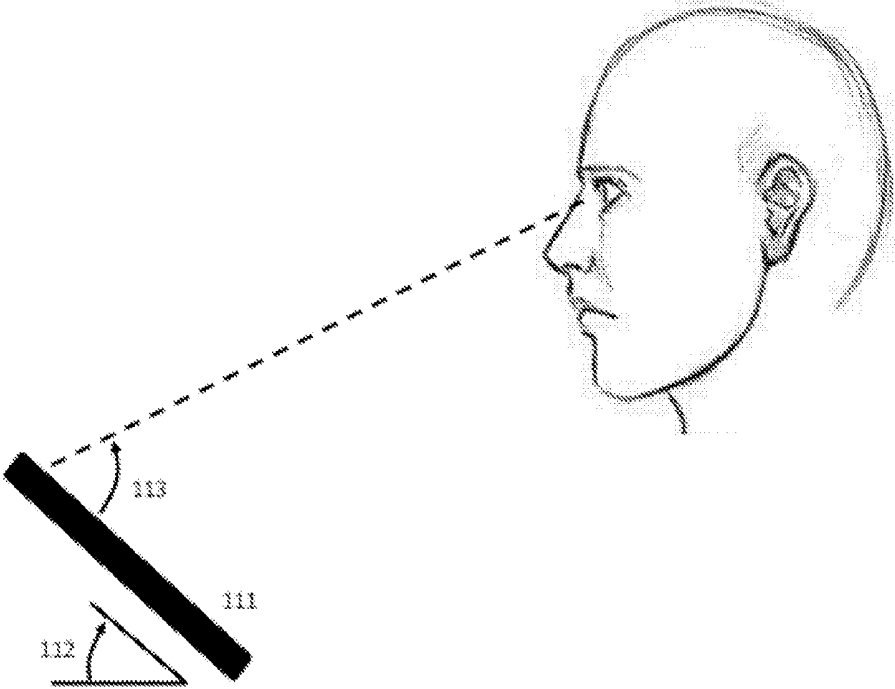

Figure 11

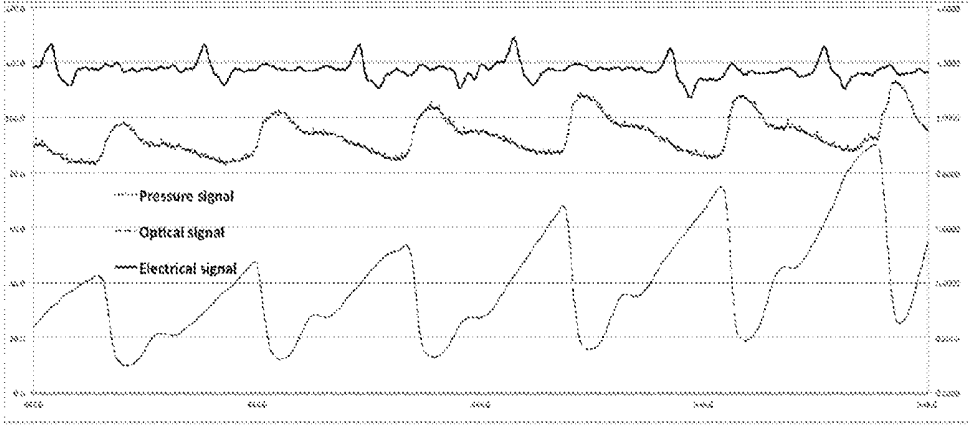

Figure 12

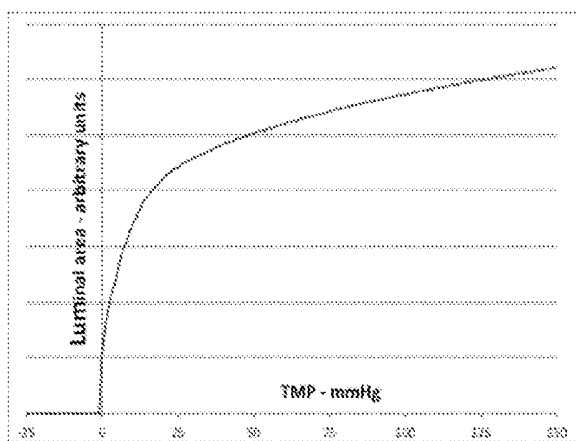

Figure 13

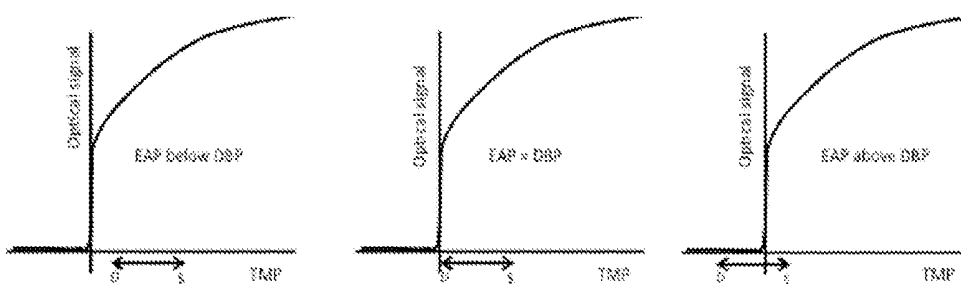

Figure 14

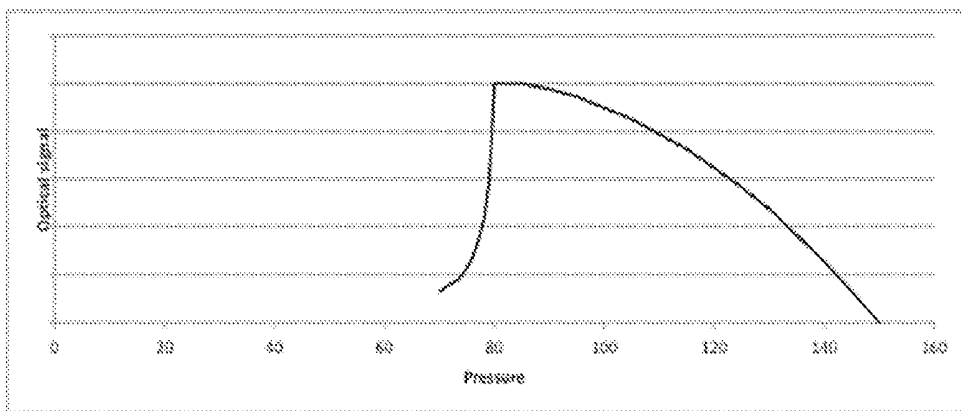

Figure 15

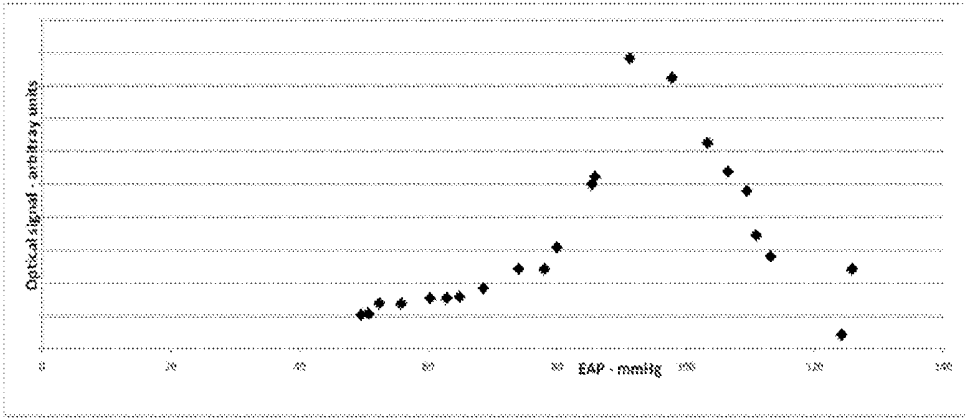

Figure 16

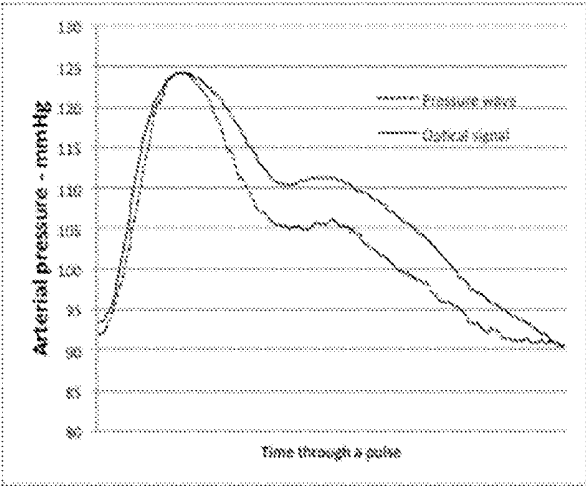

Figure 17

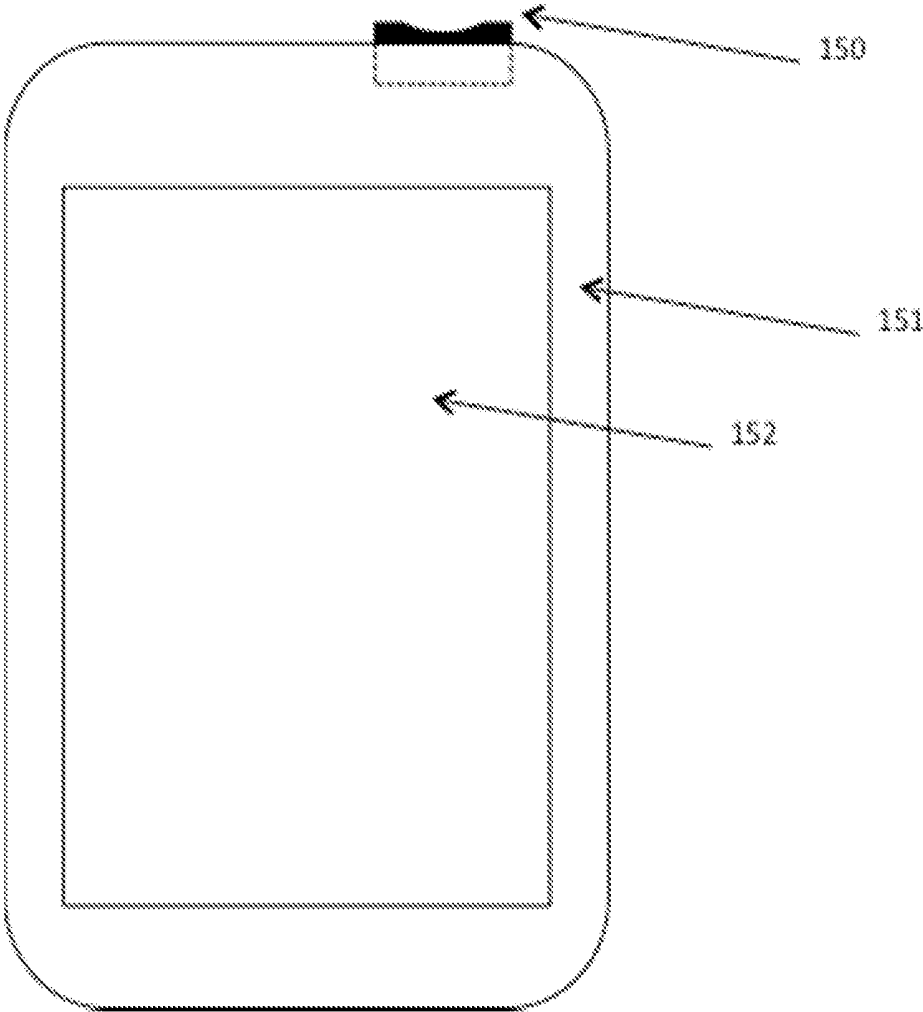

Figure 18

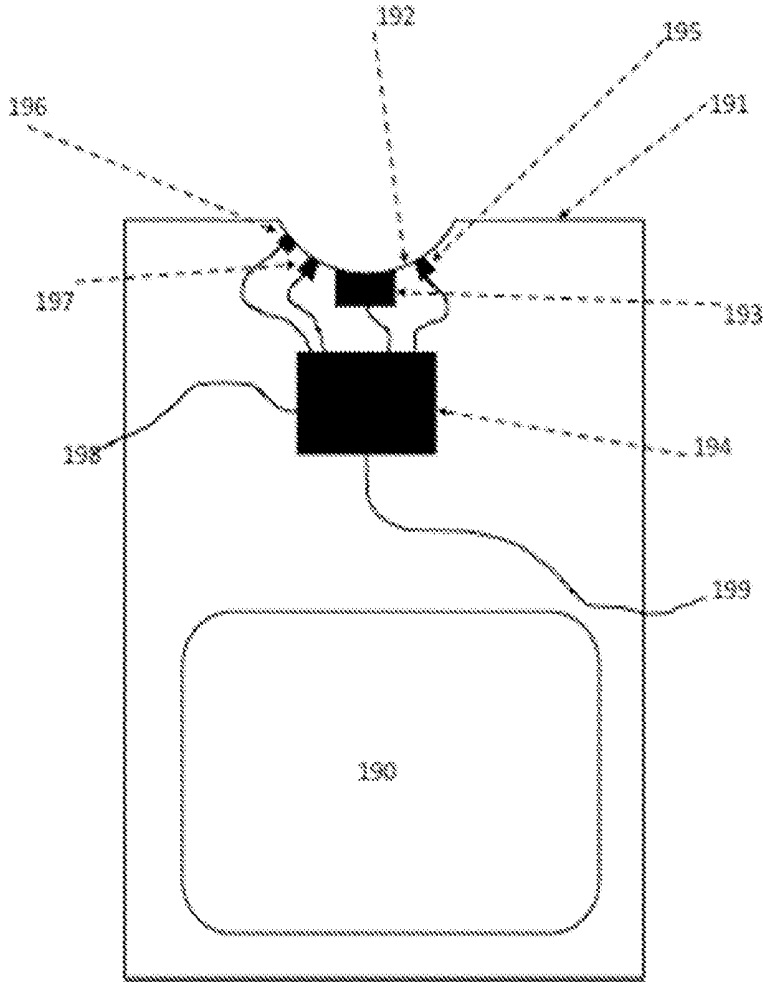

Figure 19

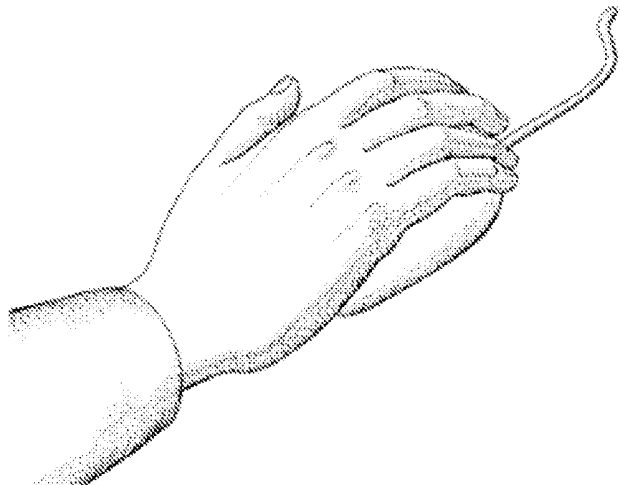

Figure 20

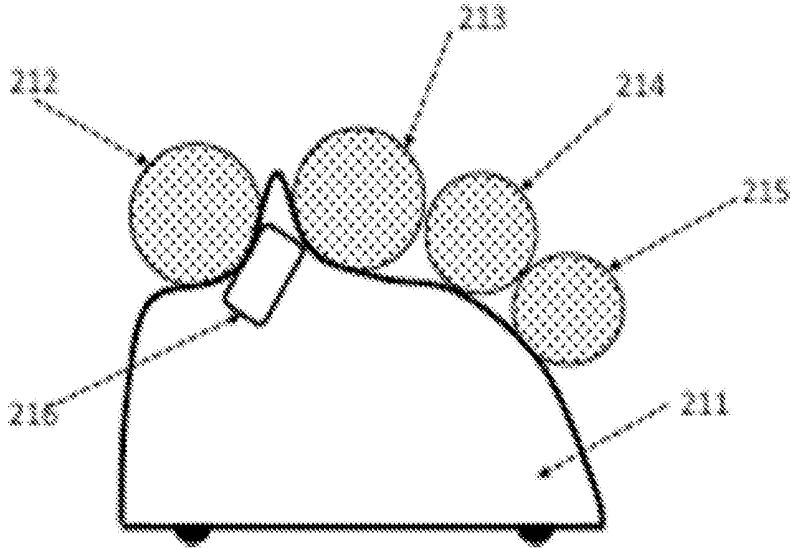

Figure 21

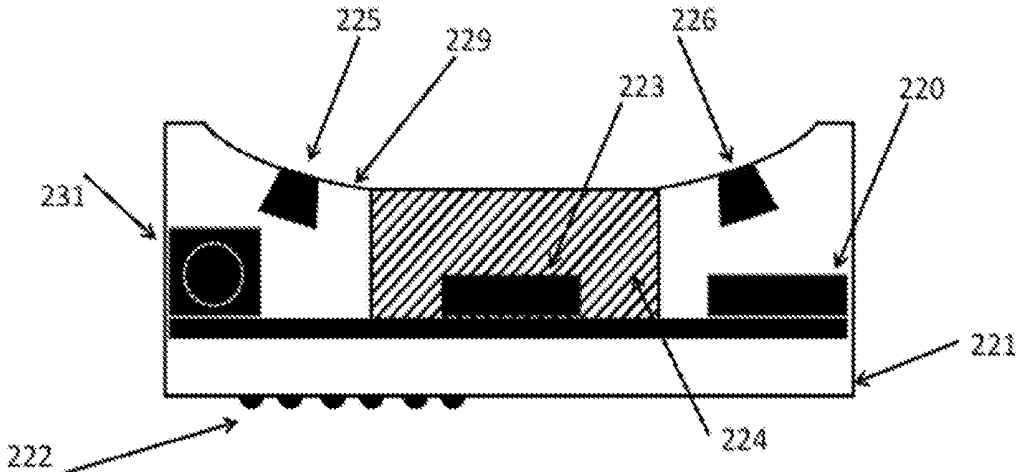

Figure 22a

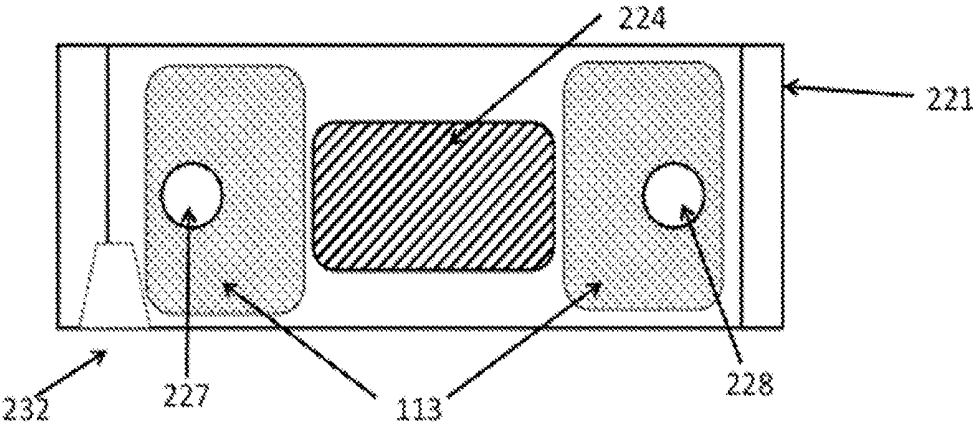

Figure 22b

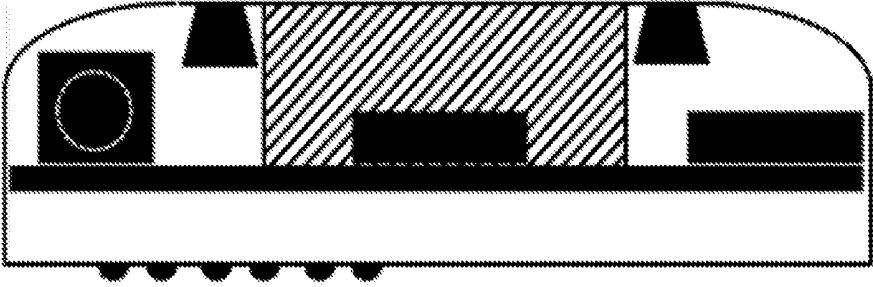

Figure 23

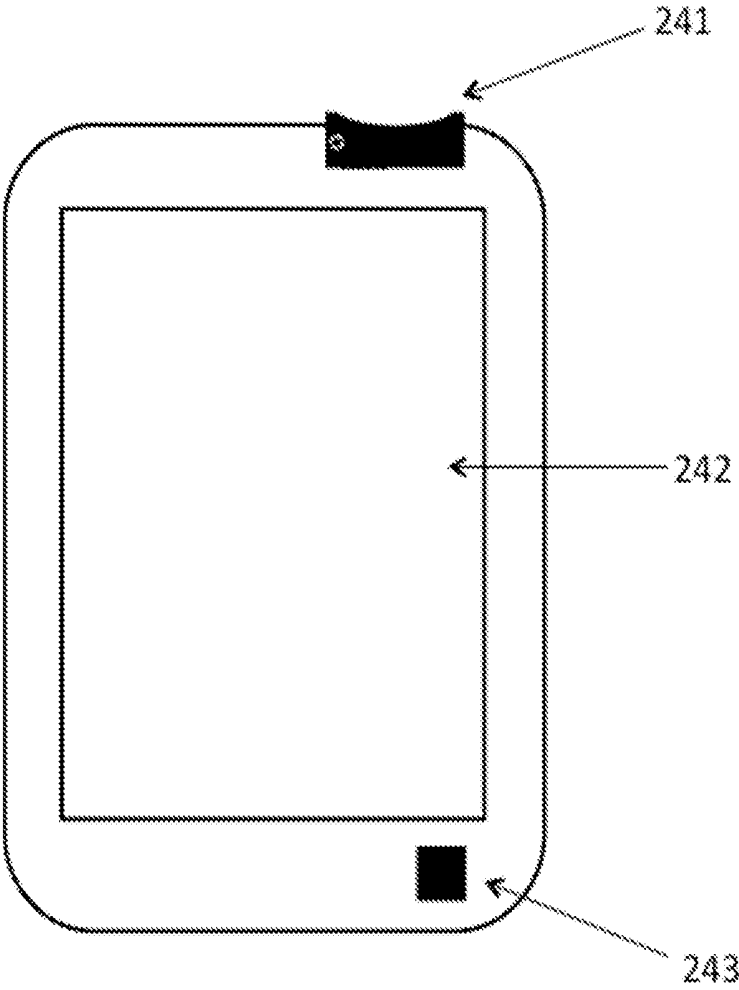

Figure 24

PERSONAL HEALTH DATA COLLECTION

FIELD OF THE INVENTION

[0001] The present invention relates to means for collecting personal health data. In particular, the invention relates to a personal hand-held monitor (hereafter “a PHHM”) comprising a signal acquisition device for acquiring signals which can be used to derive one or more measurements of a parameter related to the health of a user.

[0002] In one aspect, the signal acquisition device is integrated with a personal hand-held computing device (hereafter “a PHHCD”). Such a PHHM is primarily intended for use by consumers. The PHHM uses the processor of the PHHCD to control and analyse signals received from the signal acquisition device. The present invention also relates to a signal acquisition device adapted to be integrated with such a PHHCD.

[0003] In another aspect, the PHHM is integrated with a dedicated computing device for general use. Such a PHHM is a stand-alone device primarily intended for use by healthcare professionals.

[0004] The present invention further relates to systems for operating the PHHM and for handling the signals acquired by the signal acquisition device. The present invention yet further relates to a system for analysing, storing and transmitting signals acquired by the PHHM via the internet or for regulating the uses to which the data derived from those signals may be put.

BACKGROUND TO THE INVENTION

[0005] Cellphones (also known as mobile phones) are a part of everyday life. In the developed world, a large majority of adults have a cellphone. The use of cellphones is also becoming much more prevalent in developing countries as it enables such countries to develop a communications system without the need to install cabling. There have been various proposals for using cellphones in healthcare. However, all of these proposals have drawbacks.

[0006] Leslie, I et al., “Mobile Communications for medical care”, Final Report, 21 Apr. 2011, reports on a major study by the University of Cambridge which identified the crucial contribution that cellphone networks will make to healthcare in developed, low income and emerging countries by transferring “vital signs” and other data from local measurement devices to a central data collection and processing computer. It identified two separate industrial communities—those who make cellphones and those who make medical devices.

[0007] Ladeira D et al., “Strategic Applications Agenda Version 3”, Working Group on Leading Edge Applications, January 2010, www.emobility.eu.org, is an e-mobility study which considered the wide implications of networked health care and stated: “Smart phones can collect measurement results automatically and wirelessly from the measuring devices and seamlessly transfer the collected data to the doctor for further analysis”.

[0008] “Healthcare unwired—new business models delivering care anywhere” PricewaterhouseCoopers’ Health Research Institute, September 2010, is a study which addresses the opportunity presented by wide access to communications but from the perspective of the medical profession and its impact on the medical business model.

[0009] In a review in 2009, the Apple Company identified a growing demand for using its iPhone® as part of a commu-

nications chain from medical devices to practitioners and others (see <http://medicalconnectivity.com/2009/03/19/apple-targets-health-care-with-iphone-30-os/>).

[0010] These reports are based on the use of existing medical devices and existing cellphone technology and therefore require the presence of both a medical device industry and a cellphone industry.

[0011] Tablet computers and portable personal computers are also becoming small enough to be used as PHHCDs. Many such devices also include communications facilities such as WiFi or wireless telephone connectivity.

[0012] Personal digital assistant devices (“PDAs”) are also now well-known and include a processor for enabling a user to store and retrieve personal data.

[0013] Hand-held games consoles are also now well-known and are used to enable games to be played by a user holding the console. The console includes a processor which derives signals from various sensors in the console and transmits these to a remote station for analysis and control of the game display.

[0014] Hand-held devices are frequently used to control televisions and other domestic electronic appliances. Such hand-held devices include electronics to detect the actions of the user and communicate them to the appliance.

[0015] There is growing recognition of the importance of allowing people to take greater control of their health. The internet has given access to extensive medical and diagnostic information so that patients may interact more effectively with their doctors but there is little direct exploitation of personal measurements. For example, a review of 23,000 medical “apps” that run on smartphones or tablet computers found that only 159 of them use data from sensors (Walsh, Medtech Summit, Dublin 2013). There is a shortage of measurement devices that are accurate, affordable, easy to use and readily available. Effective integration of measurements of vital signs, such as pulse rate, blood pressure (hereafter “BP”), body temperature, blood oxygen and respiration rate, with PHHCDs would greatly enhance the value of these apps and the ability of people to manage their health.

[0016] Blood Pressure Measurement

[0017] BP is a fundamental diagnostic, used throughout the world to assess health. A recent review (Smulyan H et al., “BP measurement: retrospective and prospective Views”, American Journal of Hypertension, advance online publication 24 Feb., 2011; doi:10.1038/ajh.2011.22) opens with the words: “Measurement of the arterial blood pressure (BP) is a time-honored, vital piece of medical information whose accuracy is seldom questioned”. The basic measurements are the diastolic BP (DBP), the lowest pressure observed during the pulse cycle, and systolic BP (SBP), the highest pressure observed during the pulse cycle.

[0018] There are three established methods for measuring arterial BP without inserting a measurement device into the artery: the auscultatory, oscillometric and volume clamp methods. There are also relative measurement methods that detect changes in BP but which require calibration for each user.

[0019] The Riva-Ricci Auscultatory Method

[0020] In this method, an inflatable cuff is inflated to occlude the flow in an artery, usually the brachial (upper arm) artery. The cuff is then more slowly deflated to allow blood to begin to flow again. During deflation, Korotkoff sounds are detected using a stethoscope and the occurrence of those sounds is correlated with the pressure in the cuff as shown by

a mercury sphygmomanometer attached to the cuff. Smulyan (loc. cit.) reported that comparisons of auscultatory measurements with invasive measurements show that: "For SBP, the average differences between the two methods in the five studies ranged from 0.9 to 12.3 mm Hg with standard deviations that ranged from 1.3 to 13.0 mm Hg (FIG. 1). For DBP, the average differences ranged from 8.3 to 18 mm Hg with standard deviations that ranged from 1.1 to 9.3 mm Hg The reasons for the inaccuracy are multiple and include both observer errors and methodological errors. Some common observer errors are digit preferences, inattention, too rapid cuff deflation and hearing deficits. Methodological errors involve selection of a single beat for measurement when there are beat-to-beat variations in the pulses and sequential rather than simultaneous comparisons".

[0021] The method has other limitations: it uses a mercury column to measure pressure and there are strong environmental objections to the use of mercury; it requires a trained practitioner; putting on a cuff is inconvenient and time consuming; and the measurements are not available digitally.

[0022] The Automatic Oscillometric Method

[0023] In this method, an inflatable cuff is inflated to occlude the flow in an artery, usually the brachial or radial (wrist) artery. The cuff is then more slowly deflated to allow blood to begin to flow again. During deflation, the flow is detected by observing small pressure fluctuations introduced into the cuff by the pulse. Smulyan (loc. cit.) reported that comparisons of oscillometric measurements with auscultatory measurements show that, for an automatic device: ". . . 73, 87, and 96% of the automatic measurements must lie within 5, 10, and 15 mm Hg of the auscultatory values . . . but, there is no standardized algorithm for identifying either the oscillometric SBP or IMP, Each device manufacturer has its own algorithm for BP detection, all are proprietary and unavailable for independent study . . . other problems with the measurement include errors related to irregular cardiac rhythm, variations in the rate of cuff deflation, volume of air within the cuff and compressibility of the BA".

[0024] This method also requires the use of an inconvenient cuff.

[0025] The Volume Clamp Method

[0026] This method also uses an inflatable cuff which is inflated to hold an artery, usually a finger artery, at a constant cross-sectional area throughout the pulse cycle. The volume clamp method is less accepted and less well known than the other two methods but has the potential to be more accurate and objective than the other two.

[0027] A review by Imholz et al., (Cardiovascular Research 38 [1998] 605-616) of the Finapres® device, which operates according to the volume clamp method, found that: "Many papers report on the accuracy of the device in comparison with intra-arterial or with noninvasive but intermittent BP measurements. We compiled the results of 43 such papers and found systolic, diastolic and mean accuracies, in this order, ranging from -48 to 30 mmHg, from -20 to 18 mmHg, and from -13 to 25 mmHg We conclude that Finapres accuracy and precision usually suffice for reliable tracking of changes in BP. Diagnostic accuracy may be achieved with future application of corrective measures".

[0028] There has been further development of this method and its accuracy has improved but it is not seen as a viable alternative to the other two established methods. This may be in part because the volume clamp method is technically more complicated than the other two methods.

[0029] Relative Measurements

[0030] There are several ways of detecting changes in BP which require calibration (and sometimes frequent re-calibration) by one of the other methods in order to give an absolute value. These include applanation tonometry and measurement of pulse wave velocity. The volume clamp method also fall into this category.

[0031] WO2013/001265

[0032] WO2013/001265 discloses a PPHM comprising a signal acquisition device for acquiring signals which can be used to derive a measurement of a parameter related to the health of the user, the signal acquisition device being integrated with a PPHCD.

[0033] The PPHM of WO2013/001265 must be of such a size and weight that it can readily be manipulated by a normal adult using one hand to hold the PPHM and the other hand to enter or retrieve data. Preferably, the PPHCD includes communications facilities, such as WiFi or wireless telephone connectivity.

[0034] By "integrated" in WO2013/001265 and in the present application is meant that the signal acquisition device and the PPHCD form a single physical unit wherein the signal acquisition device and the PPHCD remain in fixed relationship when either is moved. All electrical connections are provided within the PPHM.

[0035] The acquired signals may be analogue or digital and, if analogue, may be converted to digital form for subsequent analysis by the processor of the PPHCD or for analysis by a remote data processing facility with which the PPHCD communicates using the internet or other data communication means.

[0036] The PPHCD with which the signal acquisition device of WO2013/001265 is integrated may be a cellphone, a tablet computer, a PDA, a games console or any other computing device which can readily be manipulated by a normal adult using one hand to hold the device and the other hand to enter or retrieve data.

[0037] The disclosure in WO2013/001265 shows the merging of medical technology with PPHCD technology by combining proven technological principles with novel implementation to create a PPHM which allows its user to acquire measurements of personal health data solely by using the PPHM. If desired, the user may communicate those measurements to other parties.

[0038] The use of the PPHM of WO2013/001265 is a significant improvement over the use of the systems described in the studies referred to above because the signal acquisition device is integrated with the PPHCD. Since the signal acquisition device must be small enough to be integrated with the PPHCD without reducing its portability and is able to make use of the infrastructure of the PPHCD, such as its display and battery, it will be significantly less expensive than many of the known medical devices, which are too expensive for most users in low income or emerging countries and would deter even those in developed countries. The signal acquisition device exploits micro-electronic technology to reduce size and cost to a level at which the signal acquisition device integrated with a PPHCD can become ubiquitous and personal to the user.

[0039] Preferably, the signal acquisition device of the PPHM of WO2013/001265 is adapted to acquire signals while in contact with or very close to one or more parts of the user's body.

[0040] In particular, the signal acquisition device may be adapted to acquire signals while at least a part of it is in contact with:

[0041] one or more of the user's digits, especially one or more fingers;

[0042] the skin near the carotid artery;

[0043] the user's chest, advantageously close to the heart; and/or

[0044] the inside of a user's ear or mouth.

[0045] The signal acquisition device of the PHHM of WO2013/001265 includes one or more sensors for acquiring signals which can be used to derive a measurement of a parameter which is useful in relation to personal health. Preferably, the one or more sensors is/are for acquiring signals related to BP, pulse wave velocity, BP waveform, temperature, blood oxygen partial pressure, electrocardiogram, heart rate and/or respiratory rate. The signal acquisition device may include sensors for acquiring signals from which measurements of more than one of the above-mentioned parameters can be derived. The signal acquisition device preferably includes one or more sensor(s) for acquiring signals from which measurements of BP, using, for instance, one or more of sphygmomanometry, photoplethysmography and measurement of pulse wave velocity, can be derived.

[0046] The PHHM of WO2013/001265 may include one or more of the following sensors and means. Particularly preferred combinations of these sensors and means are referred to below.

[0047] Temperature Sensor

[0048] The signal acquisition device of the PHHM of WO2013/001265 may include a temperature sensor for acquiring signals from which a measurement of local body temperature (i.e. the temperature near the location at which the sensor is applied to the body) can be derived by the processor of the PHHCD. Advantageously, the signal acquisition device also includes a sensor for acquiring signals from which a measurement of ambient temperature can be derived by the processor. This may be the same sensor as is used in connection with measuring local temperature or may be a separate sensor. Preferably, the processor is adapted to derive the user's core body temperature from the signals acquired by the temperature sensor.

[0049] As is well known, the temperature of a surface may be estimated by measuring the thermal radiation it emits. For typical body temperatures, the radiation is concentrated at far infra-red wavelengths. It may be detected by a bolometer, in which a target is heated by the incident radiation and its temperature measured, either directly by detecting the change in its resistance or indirectly using a thermocouple, thermistor or other similar device. The field of view may be defined by a lens or window. The temperature sensor may be adapted to receive radiation from the inside of the ear or the temporal artery on the forehead as in existing medical devices using this technique.

[0050] The temperature sensor is preferably positioned so as to be able to sense the temperature of the user's ear, whether or not the user is making a telephone call. Alternatively, the temperature sensor may be positioned so that it is able to make measurements of the surface temperature of the body part on which any other measurement made by the PHHM, such as a measurement of BP, is to be made.

[0051] Alternatively, the temperature sensor may be located such that the user may orientate its direction by manipulating the PHHM such that it is able to sense the

temperature of the body part or other item chosen, for example an item of the user's clothing. The processor of the PHHM may in this case be adapted to derive a signal indicative of ambient temperature and/or to provide instructions to the user to orient the PHHM so that signals indicative of body temperature and ambient temperature are obtained.

[0052] The signal acquisition device may include more than one temperature sensor for sensing temperature at different locations.

[0053] The temperature sensor may be used for measurement of the temperature of other items, for example food, domestic heating systems or wine.

[0054] Electrical Sensor

[0055] The heart is triggered by electrical signals that can be detected on the skin, which is the basis of the electrocardiogram (ECG). A simple version of this can detect the time at which the electrical signal that initiates a heartbeat occurs by measuring the potential difference between two separated parts of the body. With appropriate electronic processing, the time of occurrence of each initiation signal can be measured to within a few milliseconds.

[0056] The signal acquisition device of the PHHM of WO2013/001265 may include an electrical sensor comprising two electrodes which are electrically isolated from each other but which can be contacted by two different parts of a user's body. Preferably, the two electrodes can be contacted by one finger from each hand of the user. Preferably, one of the electrodes of the electrical sensor is associated with a blood flow occlusion means (see below). The other electrode will be located on a separate part of the PHHM. Preferably, the blood flow occlusion means is constructed with a surface that gives a good electrical connection, such as an array of micro-pyramids.

[0057] Preferably, the signal which is acquired by the electrical sensor is a measure of the potential difference between the two electrodes which is related to the potential difference between the two different body parts. Preferably, the processor of the PHHCD is adapted to amplify the signals from the electrical sensor and, if desired, to filter the signals before, during or after amplification. An amplified and filtered signal produced by the processor will generally have the form shown in FIG. 1 in the attached drawings where the x axis represents time and the y axis represents potential difference. The arrows in FIG. 1 indicate the time at which the electrical signal stimulates the heart to initiate systole.

[0058] Blood Flow Occlusion Means

[0059] The signal acquisition device of the PHHM of WO2013/001265 may comprise a blood flow occlusion means for restricting or completely blocking the flow of blood through a part of a user's body and a pressure sensor for determining the pressure applied by or to the blood flow occlusion means.

[0060] The signal acquisition device of the PHHM of WO2013/001265 preferably includes a blood flow occlusion means which can be used by pressing it against a body part, such as a toe or finger, preferably a finger, where arterial blood flow through the body part is affected by pressure exerted on only one side of the body part, or vice versa.

[0061] The degree of occlusion may be detected by an oscillometric method or by analysis of the signals from a blood photosensor as described below.

[0062] The blood flow occlusion means may comprise a button that is pressed against the body part. Preferably, the button is a region of a plate, which region may move inde-

pendently from the remainder of the plate and is connected to a force sensor. The force sensor is adapted to measure the force applied to the button but minimise the distance the button may move. Typically, the plate is of 10 mm by 20 mm with a circular button of typically of 3 to 5 mm in diameter or a non-circular button of similar area. Preferably, the distance the button moves when subject to the force of the body part is no more than 0.1 mm.

[0063] Pressing the button against the body part creates a pressure within the body part. The body part in contact with the button pushes against the button with a force approximately equal to the pressure within the body part multiplied by the area of the button. By measuring the force, the PHHM can make an accurate estimate of the pressure within the body part.

[0064] The signal acquisition device may include a plurality of buttons, each of which is connected to a separate force sensor.

[0065] Blood Photosensor for Photoplethysmography (PPG)

[0066] Pulse oximeters using PPG have been on the market since the 1980s. They are used to estimate the degree of oxygenation in arterial blood. Red and infra-red light is transmitted towards a body part. The infra-red light is more strongly absorbed by oxygenated blood than by non-oxygenated blood; red light is more strongly absorbed by non-oxygenated blood than by oxygenated blood. The change in the infra-red absorption during systole is a measure of the amount of oxygenated blood. The level of red light absorption between systoles is a measure of the total amount of blood being illuminated and is used for calibration.

[0067] Available pulse oximeters suffer from the disadvantage that they are stand-alone devices, unable to work cooperatively with other measurement devices, and required to include all of the necessary measurement infrastructure, such as batteries and displays. A pulse oximeter may be incorporated with the other aspects of the PHHM of WO2013/001265 so as to share the costs and volume of the said infrastructure and to allow it to work with those other aspects at the same time, thus providing more useful information to the user.

[0068] Preferably, the signal acquisition device of the PHHM of WO2013/001265 includes a PPG sensor. This uses one or more photosensors. The photosensor(s) may be arranged for transmission or scattering measurement. In transmission mode, the photosensor comprises one or more photo-emitters arranged to transmit light through the body part and one or more photo-detectors arranged to detect light transmitted from the photo-emitter(s) through that part. In scattering mode, the photosensor comprises one or more photo-emitters arranged to transmit light towards the body part and one or more photo-detectors arranged to detect light from the photo-emitter(s) scattered by the body part. Preferably, in scattering mode, the photo-detector(s) is(are) arranged in close proximity to the photo-emitter(s).

[0069] Preferably, in either case, the photosensor(s) is/are adapted to emit and detect light at two or more wavelengths. There may be a single, multiplexed photo-emitter adapted to emit light of two selected, different wavelengths or at least two photo-emitters, each of which is adapted to emit light of a selected, different wavelength. For either alternative of the photo-emitter(s), in one alternative, there is one multiplexed photo-detector which can detect light at the selected wavelengths. In another alternative, there are two or more photo-

detectors, each of which is adapted to detect light of a selected, different wavelength.

[0070] Preferably, one of the wavelengths is chosen so that the light is absorbed more strongly by oxygenated blood than by deoxygenated blood. A suitable wavelength is 940 nm. Another wavelength is chosen so that the light is absorbed more strongly by deoxygenated blood than by oxygenated blood. A suitable wavelength is 660 nm.

[0071] Preferably, the signal acquisition device is adapted to acquire a signal from the photo-detector(s) when no light is emitted from the photo-emitter(s). This allows a further calibration of the signals obtained at the first and, if used, second wavelength(s).

[0072] FIG. 2 in the attached drawings shows schematically the variation in oxygenated blood signal (top line), deoxygenated blood signal (middle line) and ambient light signal (bottom line).

[0073] Acoustic Sensor

[0074] The PHHM of WO2013/001265 may include an acoustic sensor for acquiring signals related to the sounds produced by the heartbeat. The acoustic sensor may be a separate microphone, geophone or vibration sensor or may be the microphone provided in a standard cellphone or tablet computer for speech reception or it may be the force or pressure sensor used to measure the pressure in the body part during arterial occlusion. Preferably the processor of the PHHM is adapted to process the signals acquired by the acoustic sensor to determine the time at which the heart beats.

[0075] FIG. 3 in the attached drawings shows a typical waveform of the "lub-dub" beat of the heart which would be acquired by the acoustic sensor. Two successive pulses are shown. The signal consists of an audio signal within an envelope of amplitude generally of the form shown in FIG. 4 in the attached drawings.

[0076] Movement Sensor

[0077] The PHHM of WO2013/001265 may also include a movement sensor which is adapted to detect the location of the part of the user's body on which the signal acquisition device is located. Preferably, the processor of the PHHM is adapted to correlate the signal from the movement sensor with the signal from a pressure sensor to enable calibration of BP measurement. Preferably, the processor of the PHHM is adapted to issue instructions audibly or visibly to the user to move the body part so that such calibration can take place. The movement sensor may be an existing component of the PHHCD. It may detect inertial forces due to the acceleration of the PHHCD or pressure changes with altitude.

[0078] Ultrasonic Sensor

[0079] The signal acquisition device of the PHHM of WO2013/001265 may include an ultrasonic sensor for forming an image of the cross-section of the artery and/or to use Doppler interferometry to estimate the flow velocity of the blood within the artery. Said ultrasonic sensor may consist of a set of individual elements that form an array.

[0080] Personal Data Entry Means

[0081] Preferably, the PHHM of WO2013/001265 includes a personal data entry means and is adapted to store other personal data. The personal data entry means is preferably a keypad or touchscreen, advantageously the normal keypad or touchscreen of the PHHCD. The data which can be entered by these means may include but are not restricted to: height, weight, waist circumference, finger diameter and age.

[0082] Further Sensors and Means

[0083] The PHHM of WO2013/001265 may further include means for applying electrical signals to the user's body and for detecting the signals produced in response to those signals, for instance to measure body properties such as body mass index.

[0084] The PHHM of WO2013/001265 may include a sensor adapted to acquire signals from which the identity of the user can be derived, such as for taking a fingerprint of the user. This makes it possible to ensure that the derived measurements relating to the user's health can be associated directly to the user. Such an identity sensor may be associated with the blood flow occlusion means or may be associated with an electrode of an electrical sensor. It is possible to locate the identity sensor in such a way that it is almost impossible for the measured medical indicators to be of any person other than the identified user.

[0085] Data Analysis

[0086] The sensors and means of the PHHM of WO2013/001265 may be used in various combinations to allow for the acquisition of various health-related data. The PHHM may include one or more of the temperature sensor, electrical sensor, blood flow occlusion means, blood photosensor for PPG, acoustic sensor, movement sensor, ultrasonic sensor and preferably includes at least the first four of these. Preferred combinations of sensors and means are set forth in the Table provided at the end of this description, together with indications of the health-related data that may be derived using these combinations. However, other combinations can be used to provide further health-related data and WO2013/001265 is not to be limited to the combinations set forth in the Table provided at the end of this description.

[0087] Algorithms relating the combination of signals from any or all of the sensors and means contained in the PHHM of WO2013/001265 and from other sensors that may be part of the PHHCD may be used to convert the acquired signals to the relevant health-related data or improve the accuracy of the deduced medical indicators ("vital signs"), such as systolic and diastolic BP. Other medical indicators that are less well-known but which are recognised by medical specialists, such as arterial wall stiffness and pulse arrhythmia, may also be extracted. Any or all of these models may be coded as software and can be loaded onto the PHHM or onto a remote computer for processing of the signals.

[0088] Preferably, the processor of the PHHM of WO2013/001265 is adapted to provide audible or visual instructions to the user to enable the user to use the PHHM optimally. In this case, it is preferred that the processor is adapted so that the instructions are interactive and based on signals received from the signal acquisition device, which can be used to determine whether the signal acquisition device is in the best position or being used correctly.

[0089] It is preferred that the processor is adapted to take multiple measurements and correlate all those measurements to provide a better indication of the health data.

[0090] Body Temperature

[0091] The accuracy of the estimate of core temperature can be improved by adapting the processor of the PHHCD of the PHHM of WO2013/001265 to provide audible or visual feedback for instructing the user to move the PHHM so as to give the maximum temperature reading, for example when the PHHM is against the user's ear and is moved to ensure that the sensor is directed to the warmest place.

[0092] Preferably, the temperature sensor is positioned in the PHHM so that the PHHM is able to cover the body part whose temperature is being measured, such as the ear. In this case, in use, the temperature may rise towards core temperature because drafts are excluded by the presence of the PHHM. The temperature sensor may be collocated or combined with a loudspeaker or other device used to reproduce sound in the PHHCD.

[0093] Preferably, the processor is adapted to record the measured temperature over a period of several seconds and to use a mathematical model to extrapolate to an expected equilibrium temperature.

[0094] The processor of the PHHM may be adapted to analyse the signals from the temperature sensor to provide an estimate of the core body temperature of the user. The processor may be further adapted to carry out analysis to identify trends in core temperature and other derived information of diagnostic value.

[0095] Pulse Rate

[0096] The time of each pulse may be determined from the electrical signal, which indicates initiation of the systole, and also from the time of arrival of the systolic pulse at the body part against which the device is pressed, indicated by the pressure on the pressure or force sensor in the occlusion means and by the absorption peak detected by the optical sensor and/or by the acoustic sensor, if present.

[0097] The average pulse rate most compatible with all of the data from each of those sensors is found by means of an optimising mathematical algorithm which the processor of the PHHCD of the PHHM of WO2013/001265 is adapted to operate. This may be a simple least-squares difference calculation with weighting or may use a Bayesian estimator or other optimising technique to find the most likely estimate.

[0098] Pulse Arrhythmia

[0099] Arrhythmia is a term used to refer to the variation of the interval between pulses. The patterns of such variations are a valuable diagnostic tool.

[0100] The variations may be obtained from the same data as is used to find the average pulse rate, again optionally using an optimising mathematical algorithm.

[0101] Blood Pressure

[0102] BP may be estimated by combining the data from four different types of evidence: pulse wave velocity, pulse volume, sphygmomanometry and pulse rate. Sphygmomanometry is itself derived from two different measurements, from the high frequency signals from the pressure sensor and from the blood photosensor(s). External data, such as height, weight, age and sex of the user, may also be exploited. There are thus five separate measurements and several pieces of data that may be combined using an optimising mathematical algorithm such as a Bayesian estimator to obtain the most reliable estimate of BP.

[0103] The resulting values are the systolic and diastolic BP at the location of the body part at which the measurement was made. Other diagnostic information may be extracted from the signals by means of further mathematical models. For example, the analysis may calculate the BP at another point on the body, such as the upper arm so as to allow direct comparison with the measurements by a conventional cuff-based sphygmomanometer. It may also calculate pressure at the aorta and also arterial stiffness.

[0104] Optionally the PHHM of WO2013/001265 may include a further temperature sensor to detect the artery to be tested.

[0105] Blood Pressure Measurements

[0106] Each of the measurements of BP is described below.

[0107] Pulse Wave Velocity

[0108] Pulse wave velocity (PWV) may be derived from pulse wave transition time (PWTT). The use of PWV to estimate BP is described in detail by Padilla et al. (Padilla J et al., "Pulse Wave Velocity and digital volume pulse as indirect estimators of BP: pilot study on healthy volunteers" *Cardio-vasc. Eng.* (2009)9:104-112), which in turn references earlier work on a similar subject from 1995 and its specific use for estimating of BP in 2000. The technique is described in U.S. Pat. No. 5,865,755 dated Feb. 2, 1999. It relies on the observation that the speed at which a blood pulse travels along the arteries is a function of the arterial BP.

[0109] Preferably, the processor of the PHHM of WO2013/001265 is adapted to derive an estimate of PWV from the signals obtained from the electrical sensor and the PPG sensor. The processor is adapted to process the signal from the electrical sensor to provide an indication of the time at which systole (the heart beat) is initiated and to process the signal from the photosensor to determine the time of occurrence of the peak in the oxygenated signal, which indicates the time at which the pulse reaches the measurement point. The interval between these is a measure of the time taken for the pulse to travel from the heart to the measurement point (the PWTT). The processor is adapted to determine the BP in relation to this interval, which is typically 300 ms for measurements at the end of the wrist or hand.

[0110] Preferably, the processor of the PHHM of WO2013/001265 is adapted to make use of two further pieces of information to estimate PWV: the time delay between the electrical initiation signal and the initiation of systole by the heart; and the length of the path between the heart and the measurement point.

[0111] Preferably, the processor is adapted to analyse an acoustic signal to extract the envelope (analogous to detection in radio signals) and to use a threshold set automatically to identify the point that indicates the initiation of systole. In practice, this could be at a defined fraction of the change from background to peak, as shown in FIG. 4 in the attached drawings, where the vertical arrows indicate the time at which the heart responds to a physiological electrical initiation signal and initiates systole. This is typically a few tens of milliseconds after the electrical initiation signal. Alternatively, the processor is adapted to match a curve to the waveform to make a more robust estimate.

[0112] Alternatively, the time delay may be estimated by measuring the PWTT to two different parts of the body, such as the carotid artery and the finger. The time delay can then be found from knowledge of the typical ratio of the path lengths from the heart to the two different parts of the body.

[0113] Preferably, the PHHM is adapted to store the time delay in non-volatile memory. It may be stored automatically when measured or entered into memory by user input using a keypad or touchscreen, advantageously the normal keypad or touchscreen of the PHHCD.

[0114] Preferably, the PHHM is adapted to store in non-volatile memory a value related to the length of the path between the heart and the measuring point. It may be entered into memory by user input using a keypad or touchscreen. The value entered may be an exact measure of the length or may be a value which is approximately proportional to the actual length, such as the user's height.

[0115] Pulse Volume

[0116] Pulse volume may be derived from the blood photosensor (PPG) of the PHHM of WO2013/001265. The use of PPG for estimating BP was reported by X. F. Teng and Y. T. Zhang at the IEEE EMBS, Cancun, Mexico, Sep. 17-21, 2003. The basic technique is the subject of U.S. Pat. No. 5,140,990, dated Aug. 25, 1992. The change of the infra-red absorption during systole is a measure of the change in volume of the artery being illuminated, which is related to the pressure within the artery.

[0117] Further data may be derived from analysis of the shape of the absorption peak during systole, such as analysis of the total area under the peak.

[0118] Preferably, for the signal for oxygenated blood, the processor of the PHHM is adapted to derive properties of the blood flow such as the relative amplitude and timing of the direct and reflected pressure wave from the shape of the curve such as from the area under the peak, its width at half-height and the height and width of the shoulder. Optionally, the processor of the PHHM of WO2013/001265 may be adapted to calculate ratios of these to reduce the effect of variations in illumination and location relative to the body part. These ratios may be used to characterise the properties of the blood flow.

[0119] The processor of the PHHM is preferably adapted to analyse the signals from the PPG sensor to provide a direct estimate of systolic and diastolic BP at the point of measurement.

[0120] Sphygmomanometry (Arterial Occlusion)

[0121] Sphygmomanometry is a mature technique for measuring BP which has been in use for more than 100 years. Variable external pressure is applied with a cuff around the body part within which an artery runs. The pressure reduces the cross-section of the artery and restricts the flow of blood during systole.

[0122] Sphygmomanometry is conventionally conducted with a cuff that surrounds the body part and is inflated to a pressure at which all blood flow is stopped; the pressure is then slowly released. Systolic BP is measured by finding the smallest pressure that completely occludes the flow. Diastolic BP is measured by finding the largest pressure that does not cause any occlusion. The flow traditionally is detected by a skilled practitioner using a stethoscope to hear the sounds of the blood flowing (Korotkoff sounds).

[0123] Automatic sphygmomanometers detect the flow either by detecting fluctuations in pressure in the cuff caused by the flow (oscillometric method, see, for example, the Free-scale Application Note AN1571, "Digital BP Meter") or by optically sensing small movements of the skin. The magnitude of those fluctuations is an indicator of the degree of occlusion. More recently, PPG has been used by combining sphygmomanometry with the measurement of pulse volume (see Reisner et al., "Utility of the Photoplethysmogram in Circulatory Monitoring" *Anesthesiology* 2008; 108:950-8).

[0124] The signal acquisition device of the PHHM of WO2013/001265 may use any blood flow occlusion means. It may use either or both of the pressure fluctuations and the measurement of pulse volume to determine the systolic and diastolic pressures.

[0125] Unlike conventional sphygmomanometry, flow may be detected at a range of pressures in any order and the data fitted to a known mathematical equation. It is preferred that the processor of the PHHM of WO2013/001265 is adapted to issue audible or visual instructions to the user to vary the force

applied to the body part to cover a wide enough range of pressures to give a good fit to that mathematical equation. For instance, if the user has not pressed hard enough against the blood flow occlusion means to occlude completely a blood vessel during a systole, the device may be programmed to issue an instruction to the user to press harder on the occlusion means (or vice versa) so that the required data can be acquired.

[0126] This capability allows the pressure applied to the occlusion means to be apparently random. In carrying out BP monitoring, the user may vary the pressure applied by or to the blood flow occlusion means in a random manner. However, the data from the blood flow sensor can be correlated with the signal from the pressure sensor of the blood flow occlusion means to fit the measured data to a known theoretical relationship between flow rate and pressure (see, for example, the model shown on page 954 of Reisner (loc. cit.).

[0127] Pulse Rate

[0128] Pulse rate may be measured separately and can be used as an indicator of BP. Al Jaafreh (“New model to estimate mean BP by heart rate with stroke volume changing influence”, Proc 28th IEEE EMBS Annual Intl Conf 2006) concludes that: “The relationship between heart rate (HR) and mean BP (MBP) is nonlinear”. The paper then shows how allowance for stroke volume can compensate for some of that non-linearity. Stroke volume is estimated separately (see below) and personal data may also be used.

[0129] Other Measurements

[0130] Blood Oxygen

[0131] The blood photosensor of the PHHM of WO2013/001265 can use PPG to estimate blood oxygen levels. At least four variables may be derived from the measured absorption at two wavelengths. These are the amplitude of the detected signal at each wavelength at systole and between systoles. The arrow in FIG. 2 shows one of the values that may be derived from these, the height of the peak corresponding to the change in oxygenated blood signal at systole. It is established that these four values may be analysed to estimate the oxygenation of the blood (see for example Azmal et al., “Continuous Measurement of Oxygen Saturation Level using Photoplethysmography signal”, Intl. Conf. on Biomedical and Pharmaceutical Engineering 2006, 504-7).

[0132] Pulse Wave Velocity

[0133] The pulse wave transition time may be measured as set out above and converted into an estimate of Pulse Wave Velocity. This information is of direct diagnostic value to a skilled medical practitioner, especially if considered with all the other data obtainable from the signal acquisition device of the PHHM of WO2013/001265.

[0134] Respiration Cycle

[0135] The state of the respiration cycle may be detected from several of the data sets measurable by the PHHM of WO2013/001265:

[0136] pulse rate (measured by an electrical sensor and a blood photosensor, see above);

[0137] mean BP (see above); and

[0138] amplitude of the systolic pulse (measured by PPG, see above).

[0139] The results of all of these measurements may be combined using an optimising mathematical algorithm such as a Bayesian estimator to obtain the most reliable description of the amplitude and phase of the respiratory cycle.

[0140] Blood Flow Rate/Heart Stroke Volume

[0141] The volume pumped by the heart on each pulse is conventionally measured using an ultrasound scan. The cross-sectional area of the aorta is estimated from the image and the flow rate from the Doppler shift. This is a mature and inexpensive technique but is only available at the doctor’s office.

[0142] Before ultrasound was readily available, a convenient and almost non-invasive technique was to estimate the time taken for blood to circulate around the body. This is related to the pulse rate and the volume pumped on each pulse. The technique used a strong-tasting but harmless chemical that was injected into a vein in the arm and the time measured before it reached the patient’s tongue and could be tasted.

[0143] The PHHM of WO2013/001265 can be adapted to allow a similar measurement to be made by perturbing the respiratory cycle. The PHHCD may be adapted to instruct the user to hold his/her breath. The level of oxygen in the lungs starts to fall and the oxygenation of the blood in the lungs falls with it. Once this blood reaches the body point at which measurements are being made, the blood oxygen level will be seen to fall. The time interval, when combined with assumed or entered data as to the path length, is a measure of flow velocity. The PHHCD then instructs the user to start breathing again and the time taken for the blood oxygen level to start to rise again may also be measured.

[0144] Remote Data Processing

[0145] The PHHM of WO2013/001265 is capable of making and displaying measurements of any or any combination or all of the “vital signs” listed above without any external data processing. Additional features and improved accuracy may be provided by external data processing, using the communications capability of the PHHCD to connect to the internet, a cellular telephone network or other communications means.

[0146] Preferably, each PHHM of WO2013/001265 has a unique, unalterable, electronically-readable identifier. This may be provided during manufacture or testing. Furthermore, each PHHM preferably includes circuitry to encrypt the measured data in a manner which is unique to that device.

[0147] The PHHCD of the PHHM of WO2013/001265 may read the unique identifier when the PHHM is first used and transmit that identifier to a remote secure data service (RSDS) by means of the Internet. The RSDS downloads to the PHHCD the necessary software, calibration data and a decryption key to extract the data from the PHHM. This is a more reliable way of ensuring the proper calibration of the signal acquisition device and minimises the time required for installation and final test of the PHHM into the PHHCD. The PHHCD is preferably further programmed to communicate the measured data directly to the user, for instance via a visual display or audibly. Preferably, the communication is via a visual display. If desired, the processor may be programmed so that the display shows not only the measured parameter(s) but also trends in the measured parameter(s).

[0148] Optionally, the software may be time-limited, requiring the user to revalidate it with the RSDS after a fixed period of time. Optionally, the user may be required to pay a licence fee for some or all of the capability to be enabled.

[0149] Alternatively, the decryption key and calibration data may be retained by the RSDS. The PHHCD transmits the encrypted raw data from the PHHM to the RSDS for analysis.

The RSDS then returns the decrypted, calibrated data for further processing and display to the user.

[0150] The RSDS may carry out further processing of the measured data to obtain greater accuracy or to derive further diagnostic or indicative data. These data may be retransmitted to the PHHCD for display to the user.

[0151] The PHHCD may also be programmed by the RSDS to transmit the acquired signals or the derived measurements to a remote location, for instance a user's, clinician's, health care provider's or insurance company's computer system where the acquired signals or measurements may be processed remotely, for instance to provide a more accurate analysis, or for the results of the analysis to be interpreted either automatically or by a skilled doctor. If the processor is so programmed, it may also be adapted to receive the results of such analysis and display such results to the user, as described above.

[0152] The PHHCD of the PHHM of WO2013/001265 may also be programmed by the RSDS to permit third party applications (commonly known as "apps") access to the data from the PHHM. Such permission may be made subject to the payment of a licence fee or to the app having been endorsed by the relevant regulatory authorities.

[0153] The PHHCD of the PHHM of WO2013/001265 may also be programmed to provide information related to the derived measurement(s), such a normal ranges or recommendations for action.

[0154] The RSDS can offer a service to store many measurements from a PHHM and analyse trends and other derived information for the user. This may be linked to an automatic alert service in the event of any significant change in the data. In addition, the signals or measurements can be anonymized and gathered from groups of or all PHHMs of WO2013/001265 so that they can be used for research purposes.

[0155] Physical Construction

[0156] A number of different sensors and means, as referred to above, can be incorporated into the PHHM of WO2013/001265. They can be incorporated individually or in any combination of two or more sensors. For instance, a combination of a sensor for measuring the pressure applied by or to a blood flow occlusion means, a photosensor for measuring blood flow in a body part to which the pressure is applied and an electrical sensor for measuring pulse rate is particularly useful for providing more accurate data for determining BP. Preferably, the PHHM of WO2013/001265 integrates one or more Application Specific Integrated Circuits (ASIC), one or more Micro-Engineered Measurement Systems (MEMS) and/or photo-emitters and/or photo-detectors. They may be integrated as separate silicon devices in a single package or, preferably, some or all of them may be incorporated on one or more silicon devices. Such integration will bring several benefits, included reduced cost, improved reliability, reduced size and mass and reduced power consumption.

[0157] Preferably, the PHHM of WO2013/001265 exploits the other capabilities of PHHCD for calibration and operation.

THE PRESENT INVENTION

[0158] The present invention provides significant improvements over aspects of the PHHM disclosed in WO2013/001265. The PHHM of the present invention addresses the weaknesses of the established methods in that: it provides

objective, precise, repeatable, absolute and accurate results; it does not use toxic materials; it is easy to use without specialist training; and it uses only inexpensive, simple and reliable technology.

[0159] The invention disclosed in WO2013/001265 includes many advances on the previous state of the art but still has limitations. This application discloses several enhancements and refinements to the PHHM as described therein that can improve its usability, cost, effectiveness and/or ease of integration with the PHHCD.

[0160] There are several aspects to the present invention. For convenience, they are described separately but it is apparent to a person skilled in the art that they may be used cooperatively to create a unified device in which the various aspects work cooperatively to share data and/or enhance their mutual performance and/or reduce costs and complexity. It will also be appreciated that the aspects of the present invention described below can be used together in any combination of two or more of the aspects, in particular for the purposes set out in the Table at the end of this description and may be used in combination with the features described above in connection with WO2013/001265.

[0161] For convenience, the description herein describes the body part as a finger, but it will be apparent to a person skilled in the art that the device may be applied to other body parts.

[0162] First Aspect

[0163] In a first aspect, the present invention relates to a PHHM as defined in WO2013/001265 and as set out above which can be applied by a user, such as the subject whose BP is to be measured or a medical practitioner who wishes to measure the BP of the subject, to a subject's body part and wherein the PHHCD is primarily intended to provide a processing means for the PHHM rather than having some other function, such as mobile telephony, to which the PHHM is added. This is referred to as a dedicated computing module. The PHHM may also be connected to a computer. The elements of the PHHM or the module in which they are integrated may be incorporated in a device designed specifically for the purpose.

[0164] In one embodiment, shown in FIG. 5, the signal acquisition device is shown at 51. The PHHM of FIG. 5 is connected to a computer by means of a cable 52. However, the PHHM of FIG. 5 may alternatively be connected to a computer by wireless means such as Bluetooth.

[0165] The PHHM of FIG. 5 may also be equipped with data entry means and a display (not shown in FIG. 5) which may be combined as a touchscreen and used to communicate with the user (the subject or a health care professional) and used by the user to activate the PHHM and to enter personal data or identifying data, such as a personal identification number.

[0166] In another form, shown in three views in FIG. 6 in the attached drawings, the PHHM is ergonomically curved to fit into the hand. The open surface 61 of the signal acquisition device and the top shape 62 is designed to hold a finger comfortably along it.

[0167] Second Aspect

[0168] In a second aspect, the present invention relates to a PHHM as defined in WO2013/001265 and as set out above comprising a signal acquisition device for acquiring signals which can be used to derive a measurement of a parameter related to the health of the user, the signal acquisition device being integrated with a PHHCD, which PHHM includes an

electrical sensor comprising at least three electrodes electrically isolated from each other but which can be contacted by different parts of a user's body. Preferably, two electrodes can be contacted by one finger from each hand of the user and a third electrode can be contacted by a hand. Preferably, one of the electrodes of the electrical sensor is associated with a blood flow occlusion means as described above in connection with WO2013/001265 or as described below in connection with the present invention. The other electrodes will be located on a separate part of the PHHM. Preferably, the electrodes are constructed with a surface that gives a good electrical connection, such as an array of micro-pyramids or a material such as silver/silver chloride.

[0169] Preferably, the signal which is acquired by the electrical sensor is a measure of the potential difference between two of the electrodes, preferably in contact with the fingers, which is related to the potential difference between the two different body parts. A third electrode is used to provide an earth reference. Preferably, the processor of the PHHCD is adapted to amplify the signals from the electrical sensor and, if desired, to filter the signals before, during or after amplification. An amplified and filtered signal produced by the processor will generally have the form shown in FIG. 1 in the attached drawings where the x axis represents time and the y axis represents potential difference. The arrows in FIG. 1 indicate the time at which the electrical signal stimulates the heart to initiate systole.

[0170] Third and Fourth Aspects

[0171] According to a third aspect of the present invention, there is provided a PHHM adapted to provide a BP measurement comprising:

[0172] a housing, the housing including an open surface against which, in use, a subject's body part can be pressed or which, in use, can be pressed against a subject's body part so that pressure can be applied to the subject's body part to occlude an artery in the body part;

[0173] a pressure sensor associated with the open surface for providing an electrical signal related to the pressure exerted by the open surface on the body part or vice versa;

[0174] an optical sensor associated with the open surface for providing an electrical signal related to the luminal area of the artery which, in use, is occluded by the open surface; and

[0175] processing means for controlling the device and for receiving and analysing electrical signals from the pressure sensor and the optical sensor to provide a measurement of the subject's SBP and/or DBP.

[0176] According to a fourth aspect of the present invention, there is provided a PHHM adapted to provide a BP measurement comprising:

[0177] a housing, the housing including an open surface against which, in use, a subject's body part can be pressed or which, in use, can be pressed against a subject's body part so that pressure can be applied to the subject's body part to occlude an artery in the body part;

[0178] a pressure sensor associated with the open surface for providing an electrical signal related to the pressure exerted by the open surface on the body part or vice versa; and

[0179] processing means for controlling the device and for receiving and analysing the electrical signals from the pressure sensor to provide a measurement of the subject's SBP and/or DBP.

[0180] The open surface must be suitable for applying pressure to a part of a subject's body or for having a part of the subject's body pressed against it. It is therefore located on an

outer surface of the PHHM. If the open surface is in a dedicated module, it is located on the face of the module which, when the module is connected to the remainder of the PHHM, is an outer face of the PHHM. Preferably the open surface is sized so that it can interact with a subject's finger. The open surface may be flat. However, preferably, the open surface is a concave area in one face of the housing. The concave area may be part circular in cross-section. Preferably, the concave area has a radius of from 5 to 15 mm, more preferably from 7 to 13 mm, most preferably from 9 to 11 mm, and an arc length of from 5 to 15 mm, more preferably from 7 to 13 mm, most preferably from 9 to 11 mm. Preferably, the open surface is saddle-shaped, i.e. it has a central part with a constant radius and has parts on either side of the central part which slope away from the central part as shown in FIG. 7 of the attached drawings (see below).

[0181] In either of the third and fourth aspects of the invention, the PHHM may also include an electrical sensor as described above with reference to WO2013/001265 or with reference to the second aspect of the present invention for providing an electrical signal related to the time at which an electrical signal which initiates a heartbeat in the subject occurs.

[0182] Fifth, Sixth and Seventh Aspects

[0183] According to a fifth aspect of the present invention, there is provided a PHHM comprising a signal acquisition device for acquiring signals which can be used to derive a measurement of a parameter related to the health of the user, the signal acquisition device being integrated with a PHHCD, which PHHM includes a blood flow occlusion means which is a button which is approximately rectangular with a length of 5 to 10 mm and a width of 5 to 10 mm or is a circular button of 3 to 5 mm in diameter or is a non-circular button of similar area.

[0184] According to a sixth aspect of the present invention, there is provided a PHHM comprising a signal acquisition device for acquiring signals which can be used to derive a measurement of a parameter related to the health of the user, the signal acquisition device being integrated with a PHHCD, which PHHM includes a blood flow occlusion means which is a button, which is at least a part of an external surface of the PHHM which is saddle-shaped, i.e. approximately of the shape shown in FIG. 7 in the attached drawings, wherein the button is physically separated from the surrounding surface. In FIG. 7 there is a curved surface 73 in one plane and, in the other plane, a central flat area 71 with curved sides 72.

[0185] Preferably, the button is covered by a thin continuous membrane to exclude contaminants. In this case, preferably, the button is co-planar with the remainder of the surface. However, the button may comprise the whole of the saddle-shaped surface. Preferably, the saddle-shaped external surface is continuous and sealed.

[0186] Preferably, the distance the button moves when subject to the force of the body part is no more than 0.01 mm.

[0187] According to a seventh aspect of the present invention, there is provided a PHHM comprising a signal acquisition device for acquiring signals which can be used to derive a measurement of a parameter related to the health of the user, the signal acquisition device being integrated with a PHHCD, which PHHM includes a blood flow occlusion means that is a sealed vessel containing an essentially incompressible fluid in which is immersed a pressure sensor which is adapted to provide electrical signals to the processor of the PHHCD. The fluid may be a quasi-solid gel or may be a liquid. The incom-

pressible fluid is preferably covered by a flexible membrane forming some or all of the occlusion means.

[0188] Preferably, the processor is adapted to extract a waveform from the electrical signals, typically similar in shape to the waveform shown in the top line of FIG. 2.

[0189] Eighth, Ninth and Tenth Aspects

[0190] Infra-red light is preferentially absorbed by oxygenated haemoglobin so the amount of absorption is approximately proportional to the amount of arterial blood through which the light passes. For a given length of artery, the amount of arterial blood is proportional to the luminal area of the artery so the absorption signal is also approximately proportional to the luminal area.

[0191] As the artery expands on each systole and contracts on diastole, the absorption of infra-red light varies with the pulse.

[0192] The optical sensor used in the device of WO2013/001265 is required to transmit only one wavelength of light, preferably in the infra-red range, to enable a measurement of BP to be taken. Thus, the optical sensor may comprise only a single photoemitter and a single photodetector. However, as the additional cost of enabling the optical sensor to transmit a second wavelength of light is small, according to a seventh aspect of the present invention, the optical sensor is able to transmit light at two wavelengths so that an estimate of blood oxygenation can be made at the same time as a measurement of BP.

[0193] According to an eighth aspect of the present invention, the processing means is adapted to correlate signals received from a pressure sensor with the signals received from the optical sensor so that the pressure exerted between an occlusion means and the body part can be correlated with the change of luminal area of the artery with each pulse as a function of the applied pressure. The correlated values can then be fitted to a curve to provide measurements of the subject's SBP and/or DBP.

[0194] According to a ninth aspect of the present invention, there is provided a PHHM comprising a signal acquisition device for acquiring signals which can be used to derive a measurement of a parameter related to the health of the user, the signal acquisition device being integrated with a PHHCD, which PHHM includes PPG sensor including one or more photosensors, wherein the or each photo-emitter and/or the or each photo-detector is/are provided with one or more lenses to narrow the field of view.

[0195] According to a tenth aspect of the present invention, there is provided a PHHM comprising a signal acquisition device for acquiring signals which can be used to derive a measurement of a parameter related to the health of the user, the signal acquisition device being integrated with PHHCD, which PHHM includes a PPG sensor including two or more photosensors, wherein there are either two photo-emitters or two photo-detectors arranged such that light emitted in two different directions can be detected, and the processor of the PHHCD is adapted to process the signals received from each direction to locate a blood vessel, preferably an artery, in the user's body. FIG. 8 in the attached drawings shows such an arrangement with one photo-detector 80 and two photo-emitters 81 and 82.

[0196] The difference between the signals received from each of the photo-emitters is indicative of the displacement of the artery with respect to them.

[0197] Advantageously, the PHHCD is adapted to provide a visible or audible signal to the user to move a body part to

optimise the position of the photo-sensor with respect to the blood vessel, preferably an artery. Alternatively, the PHHCD is adapted to compensate the signals from the photo-detector (s) when the blood vessel is not optimally positioned with respect to the photo-sensor.

[0198] Preferably, in either of the ninth and tenth aspects of the invention, the optical axes of the photo-emitter(s) and photo-detector(s) are aligned: to maximise the sensitivity of the signal produced by the photo-detectors to absorption of the emitted light by blood. FIG. 9a shows such a configuration of one photo-emitter 90 and one photo-detector 91. The two optical components are aligned so that they are both directed towards the artery 92 in order to maximise its effect on the detected signal.

[0199] Alternatively, the optical axes are aligned to minimise the sensitivity of the signal produced by the photo-detectors to the location of the blood vessel. FIG. 9b shows such a configuration of one photo-emitter 93 and one photo-detector 94. The two optical components are aligned so that a small movement of an artery relative to the optical components causes one to be better aligned and the other worse, thus reducing the effect of such a movement on the returned signal.

[0200] In a further alternative embodiment, the PHHM is adapted to detect the optical signals and pressure signals at a range of pressures and determine if these correspond to the signals of a correctly-located artery. The PHHM is adapted such that, if they are not, the PHHM will issue visible and/or audible signals instructing the user to reposition the body part and try again.

[0201] Eleventh Aspect

[0202] According to an eleventh aspect of the present invention, there is provided a PHHM comprising a signal acquisition device for acquiring signals which can be used to derive a measurement of a parameter related to the health of the user, the signal acquisition device being integrated with a PHHCD, which PHHM is adapted to detect the presence of a body part, such as a finger and adapted to initiate operation of the PHHM and, optionally, the provision of instructions to the user on receipt of a signal by the sensor.

[0203] Twelfth Aspect

[0204] According to a twelfth aspect of the present invention, there is provided a PHHM comprising a signal acquisition device for acquiring signals which can be used to derive a measurement of a parameter related to the health of the user, the signal acquisition device being integrated with a PHHCD, which PHHM includes a photo-sensor for detecting the flow of blood through a blood vessel and an electrical sensor for detecting electrical signals relating to the action of the heart and the PHHM is adapted to use the timing of events detected by the electrical sensor to determine the time or times at which to detect events in the signals produced by the photo-sensor(s).

[0205] Thirteenth Aspect

[0206] According to a thirteenth aspect of the present invention, there is provided a PHHM comprising a signal acquisition device for acquiring signals which can be used to derive a measurement of a parameter related to the health of the user, the signal acquisition device being integrated with a PHHCD, which PHHM includes a blood flow occlusion means which provides an instantaneous estimate of the pressure in the artery by acting as an applanation tonometer.

[0207] Such tonometers do not usually produce an absolute measure of pressure and have to be calibrated by another means, such as occlusion. The PHHM disclosed herein can be

adapted to combine both occlusion and applanation tonometry and so permit the blood occlusion means to be calibrated for use as an applanation tonometer by means of occlusion. This permits, for example, routine measurements to be made quickly using the applanation tonometer mode and occasional calibration measurements to be made using the occlusion mode.

[0208] The estimate of BP may be further refined by the use of other measurements. The Pulse Wave Velocity may be used to make a direct independent estimate of BP as described in detail by Padilla (loc. cit.), which in turn references earlier work on a similar subject from 1995 and its specific use for estimating of BP in 2000. The technique is described in U.S. Pat. No. 5,865,755 dated 2 Feb., 1999.

[0209] Fourteenth and fifteenth Aspects

[0210] According to a fourteenth aspect of the present invention, there is provided PPHM comprising a signal acquisition device for acquiring signals which can be used to derive a measurement of a subject's BP, the signal acquisition device being integrated with a PHHCD, wherein the signal acquisition device comprises a blood flow occlusion means adapted to be pressed against one side only of a body part or to have one side only of a body part pressed against it, a means for measuring the pressure applied by or to the body part, and a means for detecting the flow of blood through the body part in contact with the blood flow occlusion means, wherein the PHHCD is a computer pointing device, commonly referred to as a mouse, or a controller for a television or other domestic electronic appliance so that the subject may, by holding the mouse, or the controller for a television or other domestic electronic appliance enable a measurement of his or her BP and, if desired, some or all of his or her blood oxygen concentration, pulse rate and respiration rate or other physiological vital signs. The PPHM may communicate with the computer with which the pointing device or controller is being used or another computer, either by means of a cable or by wireless means such as Bluetooth.

[0211] Fifteenth Aspect

[0212] As disclosed in WO2013/001265, the PPHM creates a quasi-static pressure on the artery within the body part either by pressing the body part against the PPHM or by pressing the PPHM against the body part (WO2013/001265, page 8, line 19).

[0213] According to a fifteenth aspect of the present invention, there is provided a PPHM which comprises a signal acquisition device for acquiring signals which can be used to derive a measurement of a subject's BP, the signal acquisition device being integrated with a PHHCD, wherein the signal acquisition device comprises a blood flow occlusion means adapted to be pressed against one side only of a body part or to have one side only of a body part pressed against it, a means for measuring the pressure applied by or to the body part, and a means for detecting the flow of blood through the body part in contact with the blood flow occlusion means, wherein the blood flow occlusion means and its associated electronic components are included in a weight for producing a force between the blood flow occlusion means and the body part by acceleration of the weight.

[0214] For example, this could be a weight adapted to press against a finger and be subject to acceleration when the subject walks and swings his or her arms. As an illustration, a swing of 50 cm in 0.5 seconds would create a peak acceleration of around 10 m s^{-2} so a mass of around 50 g would create a pressure of around 200 mm Hg on an area of 20 mm^2 . It

would therefore be possible to occlude the artery by the random movements of the arm when walking with a steel ring 30 mm in diameter and 10 mm wide around the index finger.

[0215] FIG. 10 in the attached drawings shows a PPHM according to this aspect of the invention in which the elements of the PPHM are integrated. FIG. 10a shows the PPHM on a finger. The PPHM comprises a thick ring 101 for location around the middle phalanx of the index finger 102. FIG. 10b shows the cross-section of the PPHM. The ring 103 is adapted to surround the finger 104 with a soft foam padding 105 between them. A hard region 106 causes the ring 101 to press against the finger near an artery 107 and a pressure sensor and its associated electronics 108 are embedded in this hard region. Not shown is the cable or wireless connection from the pressure sensor to the PHHCD.

[0216] Sixteenth and Seventeenth Aspects

[0217] The BP measured by the PPHM of WO2013/001265 is affected by the difference in height between the PPHM and the subject's heart. The magnitude of the effect is approximately 1 mm Hg for every 13.6 mm of height difference.

[0218] Conventional measurements of BP use a brachial cuff, typically more than 100 mm wide. This uncertainty in the measurement height leads to an uncertainty of the measured pressure of the order of 7 mm Hg, although this is not apparent in testing because the ISO standard test for automatic sphygmomanometers uses the same cuff for reference as for the automatic device. There may however be a significant difference between the measured BP and the intra-arterial pressure or aortic pressure. Also, the effective height of the measurement may depend on how the cuff is fitted and how far it is above the elbow, thus reducing the repeatability of the measurements.

[0219] According to a sixteenth aspect of the present invention, there is provided a PPHM which comprises a signal acquisition device for acquiring signals which can be used to derive a measurement of a subject's BP, the signal acquisition device being integrated with a PHHCD, wherein the signal acquisition device comprises a blood flow occlusion means adapted to be pressed against one side only of a body part or to have one side only of a body part pressed against it, a means for measuring the pressure applied by or to the body part, and a means for detecting the flow of blood through the body part in contact with the blood flow occlusion means, wherein PPHM is adapted to estimate the height of the PPHM with respect to a fixed point on the subject's body.

[0220] The PPHM thus includes a system for making more accurate and repeatable measurements than can be achieved with conventional cuffs by making it possible to determine accurately the height of the PPHM. The system may operate with respect to the height of the aortic valve of the heart.

[0221] The pressure sensor or a further pressure sensor of the PPHM may be used to measure atmospheric pressure. The user may take such a measurement when the device is at the same height as the subject's heart and again when the sensor is used to measure BP. The difference between these may be used to correct the measured values of BP for the effect of hydrostatic pressure.

[0222] However, the system may alternatively operate with respect to a fixed point of the subject's anatomy. Such a fixed point is the midpoint between the centres of the pupils of the eyes. Many PHHCDs have a camera for creating an image of the subject's face. Recent PHHCDs include software to analyse that image to detect the pupils and even the direction in

which the subject is looking. Many PHCCDs also include a tilt sensor to detect the angle at which the PHHCD is being held. According to an seventeenth aspect of the invention, a combination of these devices and software is used to determine the distance of the PHHCD from the eyes by estimating the angular distance between the pupils. The angle below horizontal of the PHHCD is estimated from the position in the image of the subject's face at which the pupils are detected and the tilt of the PHHCD. These are combined by simple trigonometry to estimate the vertical distance that the PHHCD is below the subject's eyes. FIG. 11 in the attached drawings illustrates this. The dotted line shows the direction from the camera in the PHHCD 111 to the eyes, at an angle marked 113 with respect to the body of the PHHCD. The tilt angle of the PHHCD is marked 112. The angle 112 at which the PHHCD 111 is oriented is measured by a tilt sensor. The angle 113 between the PHHCD and the direction to the eyes is also measured. The estimate is then used to improve the accuracy of the determination of the subject's BP.

[0223] Eighteenth Aspect

[0224] A housing may be an integral part of device PHHM or may be part of a module which is adapted to be integrated into or attached to the remainder of the PHHM. Such a module for attachment to the remainder of the PHHM includes the housing, a blood flow occlusion means, such as described in WO2013/001265 or as described herein, a pressure sensor, an optical sensor if present, at least one of the electrodes of an electrical sensor if present and electrical connections for connecting these components to the remainder of the PHHM. Such a module for integration with the remainder of the PHHM includes the housing, an occlusion means, a pressure sensor, an optical sensor if present, at least one of the electrodes of an electrical sensor if present and mechanical and electrical connections for connecting these components to the remainder of the PHHM. Such modules form an eighteenth aspect of the present invention.

[0225] Nineteenth Aspect

[0226] According to a nineteenth aspect of the invention, the PHHM also includes a bolometric thermometer for measuring body temperature. WO2013/001265 shows how the clinical accuracy of such a bolometer may be improved by combining it with some or all of the other aspects of the PHHM.

[0227] Preferably, the temperature of the cold junction of the bolometer is determined from the temperature sensing of the other aspects of the PHHM, such as the temperature of the bridge in a pressure sensor or the temperature of an ASIC (described below) sensed by a component included within it. Alternatively, the cold junction sensor of a conventional bolometer provides an indication of the temperature of the pressure sensor bridge and/or the ASIC.

[0228] Alternatively, the temperature sensor may be located such that the user may orientate its direction by manipulating the PHHM such that it is able to sense the temperature of the body part or other item chosen, for example an item of the user's clothing.

[0229] Preferably the PHM is incorporated into a PHHCD which includes a camera and display. These may be used to display an image of the field of view over which the temperature being detected is marked.

[0230] Twentieth Aspect

[0231] As indicated above, a PHHM has been disclosed which comprises a signal acquisition device for acquiring signals which can be used to derive a measurement of a

parameter related to the health of a subject, the signal acquisition device being integrated with a PHHCD, wherein the parameter is BP and the signal acquisition device comprises a blood flow occlusion means adapted to be pressed against one side only of a body part or to have one side only of a body part pressed against it, a means for measuring the pressure applied by or to the body part, and a means for detecting the flow of blood through the body part in contact with the blood flow occlusion means, wherein the blood flow occlusion means comprises a button which is at least part of an external surface of the PHHM which is saddle shaped and the button takes the form of a flexible membrane forming a wall of a sealed vessel containing an essentially incompressible fluid in which is immersed a pressure sensor which is adapted to provide electrical signals to the processor of the PHHCD.

[0232] According to a twentieth aspect of the present invention, there is provided a PHHM which comprises a signal acquisition device for acquiring signals which can be used to derive a measurement of a subject's BP, the signal acquisition device being integrated with a PHHCD, wherein the signal acquisition device comprises a blood flow occlusion means adapted to be pressed against one side only of a body part or to have one side only of a body part pressed against it, a means for measuring the pressure applied by or to the body part, and a means for detecting the flow of blood through the body part in contact with the blood flow occlusion means, wherein the blood flow occlusion means comprises at least part of an external surface of the PHHM wherein the pressure is sensed by means of a flexible and essentially incompressible gel in which is immersed a pressure sensor which is adapted to provide electrical signals to the processor of the PHHCD.

[0233] Twenty first Aspect

[0234] A PHHM has been disclosed which comprises a signal acquisition device for acquiring signals which can be used to derive a measurement of a parameter related to the health of a subject, the signal acquisition device being integrated with a PHHCD, wherein the parameter is BP and the signal acquisition device comprises a blood flow occlusion means adapted to be pressed against one side only of a body part or to have one side only of a body part pressed against it, a means for measuring the pressure applied by or to the body part, and a means for detecting the flow of blood through the body part in contact with the blood flow occlusion means, wherein the blood flow occlusion means comprises a button which is at least part of an external surface of the PHHM which is saddle shaped, wherein the PHHM also serves as the on/off switch or some other subject-operated switch for the PHHCD.

[0235] This may be achieved by means of a physical action, such as by applying force to the PHHM, or by placing the body part in the path of a photo-detector, which may detect the presence of the body part from the change in light intensity detected.

[0236] According to the a twenty first aspect of the present invention, there is provided a PHHM which comprises a signal acquisition device for acquiring signals which can be used to derive a measurement of a parameter related to the health of a subject, the signal acquisition device being integrated with a PHHCD, wherein the PHHM is used to provide a continuously variable means for the subject to control some function of the PHHCD other than the measurements that are made by the PHHM. Such a PHHM is adapted for continuous, or analogue, control by varying the force applied to pressure

sensor, which is then used to control a property of the PHHCD, such as volume or screen brightness.

[0237] Twenty second Aspect

[0238] It is well-known that accurate blood pressure measurements require the subject to be calm and relaxed for a few minutes before taking the measurement. Many PHHCDs have sensors built in that allow them to detect movement and vibration. In the twenty second aspect of the present invention, if the PHM is incorporated in such a PHHCD, said sensor may be used to detect movement of the PHHCD which, if the user is holding the PHHCD, can be used to warn the user to sit calmly for a few minutes or even to prevent any measurements being made until the PHHCD has been at rest for such a time.

[0239] Twenty Third Aspect

[0240] In the twenty third aspect of the present invention, the PHHM is adapted to detect the optical signals and pressure signals at a range of pressures and determine if these correspond to the signals of a correctly located artery. If they do not, the PHHM is adapted to issue visible and/or audible signals instructing the user to reposition the body part and try again. This aspect may be further adapted to provide multiple passes through a measurement sequence to refine the accuracy of the measurement or to reduce the time required to obtain a measurement.

[0241] The PHHM

[0242] Preferably, the PHHM according to any of the aspects of the present invention is of such a size and weight that it can readily be manipulated by a subject using one hand to hold the device against a finger of the other hand to make a measurement or by a medical practitioner holding the device against the subject. Preferably, the PHHM is rectangular, having an upper and a lower face connected by four side faces, wherein the upper face is of sufficient area to accommodate a display means and a data entry means, the distance between the upper and lower faces is small enough to be located on the subject's body part and the open surface is located on one of the side faces. The PHHM may have a width of from 5 to 20 cm, a length of from 10 to 30 cm and a depth of from 0.5 to 2.0 cm. The PHHM may have rounded corners and edges.

[0243] Pressure Sensor

[0244] Pressing the occlusion means against a body part, such as a finger, or vice versa creates a pressure within the body part. The pressure sensor measures, directly or indirectly, the pressure between the occlusion means and the body part.

[0245] The pressure sensor may measure the pressure directly. For instance, the pressure sensor may comprise a pressure-responsive device immersed within a sealed vessel containing an essentially incompressible fluid. The fluid may be a quasi-solid gel or may be a liquid. The incompressible fluid is preferably covered by a flexible membrane forming some or all of the occlusion means.

[0246] Alternatively, the pressure sensor may measure the pressure indirectly. For instance, the pressure sensor may comprise a force-responsive device connected to a region of the occlusion means, which region may move independently from the remainder of the occlusion means. Typically, the region is circular and from 3 to 5 mm in diameter or is non-circular and of similar area. Preferably, the distance the region moves when subject to interaction with a body part, such as a finger, is no more than 0.01 mm. Preferably, the region is co-planar with the remainder of the occlusion means and may be covered by a thin continuous membrane to

exclude contaminants. In use, when a body part, such as a finger, is in contact with the region, the pressure between the body part and the occlusion means is approximately the force measured by the force-responsive device divided by the area of the movable region.

[0247] The pressure sensor may include a plurality of pressure-responsive or force-responsive devices.

[0248] By measuring the pressure or force, the device can make an accurate estimate of the pressure within the subject's body part. As explained below, provided that the occlusion means and the body part are in contact for a sufficient period of time and the pressure between the occlusion means and the body part is varied sufficiently, the processing means can analyse the signals received over a period of time and varying over a range of pressures from the pressure sensor to determine the SBP and/or DBP of the subject. It has been found that it is possible to fit the signals received from the pressure sensor, in whatever order they are received, to a curve from which SBP and/or DBP can be determined.

[0249] Optical Sensor

[0250] The optical sensor provides an electrical signal related to the luminal area of the artery by means of the absorption of light. It draws on the experience of pulse oximeters using photoplethysmography (PPG). As noted above, such pulse oximeters have been on the market since the 1980s. They are used to estimate the degree of oxygenation in arterial blood. The same principles as are described above in connection with the disclosure in WO2013/001265 apply equally to all the aspects of the present invention. Red and infra-red light is transmitted by one or more photoemitters towards a body part and detected by one or more photodetectors after the light has passed through or been reflected by the body part. The infra-red light is more strongly absorbed by oxygenated blood than by non-oxygenated blood (a suitable wavelength is 940 nm); the red light is more strongly absorbed by non-oxygenated blood than by oxygenated blood (a suitable wavelength is 660 nm). The ratio of the fractional changes in red and infra-red intensity is monotonically related to the percentage of oxygenation of the blood. It is also possible to use green light (a suitable wavelength is 520 nm) in place of the red or infra-red light.

[0251] Infra-red light is preferentially absorbed by oxygenated haemoglobin so the amount of absorption is approximately proportional to the amount of arterial blood through which the light passes. For a given length of artery, the amount of arterial blood is proportional to the luminal area of the artery so the absorption signal is also approximately proportional to the luminal area.

[0252] As the artery expands on each systole and contracts on diastole, the absorption of infra-red light varies with the pulse.

[0253] The processing means correlates the signals received from the pressure sensor with the signals received from the optical sensor so that the pressure exerted between the occlusion means and the body part is correlated with the luminal area of the artery. The correlated values can then be fitted to a curve to provide measurements of the subject's SBP and/or DBP.

[0254] Artery Location

[0255] Preferably, the PHHM is adapted to use the optical sensor as described in WO2013/001265 or as described above, in particular in connection with the eighth, ninth, tenth and nineteenth aspects of the invention for locating the artery.

[0256] Processing Means

[0257] The electrical signals produced by the sensor(s) of the PHHM may be analogue or digital and, if analogue, the signals may be converted to digital form, by an analogue-to-digital converter in the sensor or in the processing means, for subsequent analysis. Preferably, the processing means includes one or more amplifiers for amplifying the electrical signals received from the sensor(s) in the device. The processing means may also include filtering means and/or conditioning means for filtering and/or conditioning the received electrical signals. The filtering and/or conditioning means may be arranged operate before, during or after amplification of the received electrical signals.

[0258] Preferably, the processing means includes one or more Application Specific Integrated Circuits (ASIC) and/or one or more Micro-Engineered Measurement Systems (PHHMS). The processing means will include any electronic circuitry associated with the sensor(s) in the device.

[0259] The processing means may comprise a number of separate electronic devices which are preferably integrated into a single package. However, advantageously, some or all of the electronic devices are integrated into a single unit. Such integration will bring several benefits, including reduced cost, improved reliability, reduced size and mass and reduced power consumption.

[0260] Preferably, the processing means is adapted to cause the photoemitter(s), when present, to be switched so that a single multiplexed photo-detector can detect light at the selected wavelengths. Preferably, the processing means is adapted to allow an electrical signal to be acquired from the photodetector(s) for a period in which no light is emitted from the photoemitter(s) to allow a further calibration of the signals.

[0261] Preferably, the processing means is adapted to:

[0262] control and receive electrical signals from the sensor(s) in the device;

[0263] analyse the electrical signals from the sensor(s) in order to determine the BP and, preferably, other diagnostic information; or

[0264] control the display means, if present, for communicating the result of the measurement to the user.

[0265] The processing means may also be adapted to receive and process electrical signals from the data entry device, if present.

[0266] Preferably, the activities associated with artery location are carried out during the initial phase of a two-phase measurement cycle. In the initial phase, the PHHM makes measurements to locate the artery and/or other measurements that ensure that the subsequent phase will be accurate and efficient, such as approximately determining SBP and DBP. In the second phase, the PHHM makes the accurate measurements.

[0267] Preferably, the processing means includes one or more storage devices, such as a flash memory, for storing the electrical signals received from the sensor(s) and/or input from the data entry device and any electrical signals derived from the received signals. In particular, a storage device is preferably provided for storing the historical BP data derived by the processing means for each subject.

[0268] The processing means may also be adapted to communicate with a remote computer, preferably wirelessly via the internet, to allow the output of the processing means to be further analysed, archived and/or communicated.

[0269] Preferably, the processing means is adapted to provide audible or visual instructions, advantageously via the display means, if present, to the user to enable the user to use the device optimally. This includes instructions to vary the force applied to the body part to cover a wide enough range of pressures to give a good fit to the mathematical equation. For instance, if the occlusion means has not been pressed hard enough against the body part to occlude completely an artery during a systole, the device may be programmed to issue an instruction to the user to press harder on the open surface (or vice versa) so that the required electrical signals can be acquired. In this case, it is preferred that the processing means is adapted so that the instructions are interactive and based on signals received from the sensor(s) which can be used to determine whether the device is in the best position or being used correctly.

[0270] The PHHM of any of the aspects of the present invention may also include: a display means for displaying measurements of the subject's SBP and/or DBP; and/or communications means for transmitting the measurements of the subject's SBP and/or DBP; and/or storage means for storing the measurements of the subject's SBP and/or DBP. If present, the storage means may also store other data sent to or generated by the processing means.

[0271] The PHHM of any of the aspects of the present invention may also include a data entry device adapted to be operated by the user so that the user can enter information into the device. The data entry device may be a keypad or a touchscreen. The data entry device may be used to input data for identifying a subject or other user so that different subjects and/or users can use the device. The data that can be entered by use of the data entry means may include, but are not restricted to, the subject's height, weight, waist circumference, finger diameter and age.

[0272] Operation of the PHHM

[0273] The PHHM is operated by holding the occlusion means against a body part, such as a finger, or holding the body part against the occlusion means and varying the force exerted by the body part on the occlusion means or exerted by the occlusion means on the body part to achieve a range of pressures in the body part from below DBP to above SBP. While the force of interaction between the body part and the occlusion means is being varied, the sensor(s) in the device are switched on and the electrical signals generated by the sensor(s) are received and processed by the processing means.

[0274] Unlike conventional sphygmomanometry, flow may be detected at a range of pressures in any order and the data fitted to a mathematical equation.

[0275] Analysis of the Electrical Signals

[0276] The waveforms of typical electrical signals received from optical, pressure and electrical sensors are shown in FIG. 12 in the attached drawings. The primary signals that the processing means extracts from these are the change in absorption on systole (from the optical sensor) and the instantaneous measured pressure at systole and diastole (from the pressure sensor). From these, it is adapted to compute an estimate of the change in the optical signal as a function of pressure. Preferably, the processing means is adapted to use the timing of events detected by the electrical sensor to determine the time or times at which to detect events in the optical and pressure signals.

[0277] The change in the optical signal has already been shown to be approximately proportional to the luminal area of

the artery. The relationship between the luminal area and pressure is referred to as the Arterial Optical/Pressure Curve (AOPC).

[0278] In order to explain the form of the AOPC, it is necessary to consider how the artery behaves. The relationship between luminal area and pressure is as shown in FIG. 13 where TMP is the TransMural Pressure, which is the instantaneous pressure in the artery minus the External Applied Pressure (EAP), which is the pressure generated by the occlusion means and measured by the pressure sensor. Such curves have been reported by several researchers, such as Drzewiecki et al., "Theory of the oscillometric maximum and the systolic and diastolic detection ratios", *Annals of Biomedical Engineering*, 1994, 22, 88-96 and Langeworters et al., "Pressure-diameter relationships of segments of human finger arteries" *Clin. Phys. Physiol. Meas.*, 1986, 7, 43-55, both using in vitro measurements of representative arteries.

[0279] Where the applied pressure is less than DBP, the artery remains open throughout the pulse cycle. The change in luminal area that is approximately proportional to the electrical signal produced by the optical sensor is caused by the stretching of the artery wall as the pressure difference between the inside and outside rises. Where the applied pressure is greater than DBP and less than SBP, the artery collapses during every pulse and, when open, stretches as in the previous case. When the applied pressure is greater than SBP, the artery remains closed throughout the pulse cycle. This is illustrated in FIG. 14.

[0280] The quantitative form of the AOPC is found by fitting the measured values of the optical signal to a parametric representation of the AOPC, such as that proposed by Langeworters et al. (loc. cit.). The parameters of the AOPC may also be informed by an estimate of the arterial stiffness from the Pulse Wave Velocity, derived from the Pulse Wave Transit Time, which in turn is related to the time interval between the peak of the electrical signal and the peak of the optical signal. This technique is described in detail by Padilla (loc. cit.).

[0281] The amplitude of the AOPC at each of DBP and SBP, corresponding to the two ends of the bars marked D . . . S in FIG. 14 is plotted against EAP to give a curve of the form shown in FIG. 15. This Figure shows a simulation for SBP=150 mm Hg and DBP=80 mm Hg. SDB and DBP are marked respectively by the arrows "S" and "D". FIG. 16 shows a measured version of this curve. The processing algorithms use curve fitting routines to estimate DBP and/or SBP to high precision. In particular, there is a clearly visible transition at DBP, a feature absent from measurements made by all other non-invasive sphygmomanometers.

[0282] The electrical signals received by the processing means may be further analysed to extract an estimate of the pressure waveform throughout the pulse cycle. Preferably, the analysis uses one or both of two independent methods: the pressure deficit method and the pulse timing method.

[0283] The pressure deficit method exploits the instantaneous balance between the pressure within the artery and the sum of the pressure applied by the occlusion means (EAP) and the pressure caused by the tension in the artery wall (TMP). Measured values of the optical signal are used to find the corresponding TMP from the AOPC. The instantaneous arterial pressure is then found by adding the TMP to the measured instantaneous EAP. The curve in FIG. 17 shows the result of such a calculation.

[0284] The pulse timing method identifies the times during the pulse cycle at which the optical signal changes from a large signal (small absorption) to a small signal (large absorption) and back, each time being measured with respect to the time of the peak of the electrical signal. The artery opens when the pressure within it exceeds the pressure applied by the occlusion means and collapses when the pressure falls below it. The pressure applied by the occlusion means at the time of these events allows the instantaneous pressure to be mapped through the pulse cycle.

[0285] Preferably, the instantaneous pressure wave derived from either or both of these methods is then used to model the effect of the reflection of the pulse wave from the body part, which in turn may be used to estimate the pressure at other parts of the body including, but not restricted to, the wrist, upper arm and aorta (see, for example, Stergiopolus et al., "Physical basis of pressure transfer from periphery to aorta: a model-based study" *Am. J. Physiol.*, 1998, 274, H1386-H1392).

[0286] Preferably, the models used to analyse the data make use of information provided by the subject such as height, weight, waist circumference, finger diameter and age.

[0287] The estimate of blood pressure may be further refined by the use of other measurements. The Pulse Wave Velocity may be used to make a direct independent estimate of blood pressure as described in detail by Padilla (loc. cit.), which in turn references earlier work on a similar subject from 1995 and its specific use for estimating of BP in 2000. The technique is described in U.S. Pat. No. 5,865,755 dated 2 Feb., 1999. Once the form of the AOPC is found, it is possible to compute the instantaneous pressure throughout the pulse cycle. This allows the PHHM to perform the functions of a tonometer. It also permits a rapid estimate to be made of SBP and DBP, within one cycle, so allowing beat-to-beat monitoring of blood pressure.

[0288] In a further aspect of the analysis, it is well known that respiration modulates the timing of the heartbeat, the amplitude of the ECG signal, the mean and pulse blood pressure and possibly also the Pulse Wave Velocity. The analysis exploits all of these to make several independent measurements, using: the pulse period derived separately from the red and infra-red channels of the optical sensor and from the electrical sensor, the phase difference between said optical and electrical signals, the amplitude and mean values of the PPG signal and the amplitude of the ECG signal. All of these may be subject to noise or inaccuracy. Each is independently analysed to establish its quality, measured using parameters such as the repeatability of the periodicity and the signal/noise ratio. The independent measurements are then combined to give a robust estimate of respiration rate and depth by including all where the quality exceeds an empirically determined threshold.

[0289] Some or all of the data analysis of the signals concerning blood pressure may be conducted on the remote computers. This allows more demanding calculations to be provided, such as the analysis required to find the AOPC and to enable the PHHM to be used as a tonometer. Communication with the remote computers also permits the results to be archived and, if the user so instructs, transferred electronically to third parties such as the user's personal doctor, a medical specialist or a medical or life insurer.

[0290] Further aspects of the aspects of the invention are defined in the dependent claims. The various aspects of the invention disclosed herein may be used in any combination.

[0291] Illustrations

[0292] A number of embodiments of the present invention will now be described by way of example only with reference to the accompanying drawings. It should be clearly understood that the following description is provided purely by way of illustration and that the scope of the invention is not limited to this description; rather the scope of the invention is set out in the attached claims.

[0293] In the attached drawings:

[0294] FIG. 1 shows a generalised amplified and filtered signal acquired by an electrical sensor;

[0295] FIG. 2 shows schematically the variation in oxygenated blood signal (top line), deoxygenated blood signal (middle line) and ambient light signal (bottom line) acquired from a PPG sensor;

[0296] FIG. 3 shows a typical signal waveform of the “lub-dub” beat of a heart acquired by an acoustic sensor;

[0297] FIG. 4 shows the envelope derived from the acoustic signal of FIG. 3; FIGS. 5 and 6 show PHHMs according to embodiments of the present invention; FIG. 7 shows a saddle shaped surface useful as part of a blood occlusion means as disclosed herein; FIGS. 8 and 9 show possible configurations of photo-emitters and/or photo-detectors;

[0298] FIG. 10 shows a dynamic pressure device; FIG. 11 shows the geometry for estimating the height of a PHHCD relative to a subject's eyes; FIG. 12 shows typical signals produced by optical, pressure and electrical sensors;

[0299] FIG. 13 shows an illustration of a BP measurement derived from the electrical signals illustrated in FIG. 12;

[0300] FIG. 14 illustrates the range of arterial pressures from diastolic to systolic on the curve of FIG. 13 at various values of External Applied Pressure (EAP); FIG. 15 shows a theoretical Arterial Optical/Pressure Curve (AOPC);

[0301] FIG. 16 shows a measured AOPC; FIG. 17 shows a reconstructed arterial pressure wave compared with the measured optical signal;

[0302] FIG. 18 shows a cellphone adapted to operate according to the present invention; FIG. 19 shows a sketch of one embodiment of a PHHM according to the invention;

[0303] FIG. 20 shows the way in which a subject holds a computer pointing device (“mouse”);

[0304] FIG. 21 shows a cross-section through the fingers of a subject and computer pointing device; FIG. 22 shows a representation of a module having components of a PHHM integrated therein;

[0305] FIG. 23 shows a different shape of module similar to that shown in FIG. 22; and FIG. 24 shows a module including the elements of a PHHM incorporated within a PHHCD.

[0306] All of the illustrated embodiments of the PHHM include one or more electronic components (not shown) that can include: one or more pressure sensors, one or more analogue to digital converters, one or more temperature sensors, a unique identifier and an interface to the electronic circuits of a PHHCD such as a cellphone. All of the sensors and these components are preferably built within a single module, typically 10 mm×6 mm×4 mm in dimensions. The module is adapted to be installed in the top corner of a cellphone, as

shown in FIG. 18. The module 150 replaces the on/off switch in the cellphone 151 and the user is informed via the cellphone's screen 152.

[0307] FIG. 19 shows a sketch of one embodiment of a PHHM according to the invention, comprising a housing 191 including a blood flow occlusion means in the form of a part-circular open surface 192, which has a width of approximately 10 mm and a depth of approximately 3 mm. A pressure sensor 193, in this case a pressure-responsive device, is located in the centre of the open surface 192. A processing means 194 is connected to the pressure sensor (193) and to one or more photoemitters 195, one or more photodetectors 197 and an electrode 196 forming part of an electrical sensor. Separate cables run to a second electrode 198 forming another part of the electrical sensor. The illustrated PHHM includes a data entry means in the form of a touchscreen 190 which is connected to the processing means by a cable 199. Alternatively, the touchscreen may be connected by a wireless system such as Bluetooth. The touchscreen 190 can be used by the user (the subject or a health care professional) to activate the PHHM and to enter personal data or identifying data, such as a personal identification number.

[0308] FIG. 20 shows the way in which a subject holds a computer pointing device (“mouse”). FIG. 21 shows a cross-section through the fingers of a subject and computer pointing device, where there is the index finger 212, middle finger 213, ring finger 214 and little finger 215. The sensors 216 of the PHHM are incorporated in the body of the pointing device and the index finger rests against them.

[0309] FIG. 22 shows a representation of a module having components of a PHHM integrated therein which may be incorporated by others into their products. FIG. 22a shows a cross-section and FIG. 22b a plan of the module, intended for use where the body part is a finger and incorporating aspects of the invention. The length of the module is approximately 10 mm. The module includes a housing 221 with electrical connectors 222 to connect the module to another device, a pressure sensor 223 embedded in gel 224, infra-red and visible light emitting diodes 105 and photo-detector 226. They access the body part via the windows 227 and 228. The module includes an occlusion means in the form of an open surface 229 against which a finger is pressed. The module includes an ASIC 220 and a bolometric temperature sensor 231, shown as a separate device from the ASIC. Alternatively, it could be incorporated as part of the same ASIC. The bolometric temperature sensor 231 has a window 232 in the side of the module. The module includes two electrodes 223 adapted to be touched by the body part when it is pressed against the open surface 229. Not shown is a further electrode which is adapted to make contact with another body part.

[0310] FIG. 23 shows a different shape of module similar to that shown in FIG. 22 but shaped for use where the body part is the wrist.

[0311] FIG. 24 shows a module including elements of a PHHM incorporated within a PHHCD such as a cellphone. FIG. 24 shows a possible arrangement, with the module 241 located in the position where the on/off switch would normally be in the PHHCD. The PHHCD includes a touchscreen display 242 and a third electrode 243 for the electrical sensor.

Health-related parameter	Measurement technique	Relevant sensors	Notes
Body temperature	Bolometry	Temperature sensor	Bolometry is a mature technique. ThePHHM preferably uses feedback to guide the user to obtain the highest value (for example by moving around over the ear) and a model to extrapolate the changes as measured to estimate an asymptotic value and to correct for ambient.
Pulse rate	Timing of pulses	Electrical sensor	The signal from the electrical sensor will be the most reliable and precisely timed. The signals from the two sensors will also be analysed to provide confirmation of the data and to improve accuracy. The analysis will, like that for BP, seek the most likely value in the light of all of the available evidence.
Pulse arrhythmia	Timing of pulses	Pressure sensor Blood photosensor	
BP (systolic and diastolic)	Pulse Wave Transition Time (PWTT)	Electrical sensor Blood photosensor Acoustic sensor Personal data	Pulse Wave Velocity (PWV) is a direct measure of BP. The electrical sensor may be used to detect the time of initiation of the pulse. The acoustic sensor may be used when the user first calibrates the device to measure the time between electrical signal and start of systole. The PPG sensor may be used to detect the time at which the pulse reaches the finger. The personal data may be used to estimate the path length from heart to PPG sensor.
	Pulse volume	Blood photosensor	The magnitude of the PPG signal is a measure of the change in arterial volume, which is related to BP.
	Sphygmomanometry (occlusion)	Pressure sensor Optical absorption	The applied pressure is measured by the pressure in the pad or the force on the strap or button. The blood flow rate can be detected by small changes in the pressure caused by changes in volume of the artery. The pulse volume depends on the external pressure, unaffected if it is less than diastolic and falling to zero at systolic.
	Timing of pulses	As pulse rate	There is a correlation between pulse rate and BP. Personal data, including records or previous measurements, will add to its relevance.
	Applanat ⁿ tonometry	Pressure sensor	The pressure sensor may also be used as an applanation tonometer, with calibration by occlusion
Blood oxygen	PPG	Blood photosensor	Standard PPG technique, combining measurements of infra-red and visible absorption when the pulse reaches the finger.
Pulse Wave Velocity	PWTT	As above, in BP measurement	
Respiration cycle	Effect on BP and pulse	Blood photosensor Electrical sensor	The respiration cycle is manifested in changes to the interval between pulses, the mean level of BP and the magnitude of the PPG signal The respiration cycle is manifested in changes to the interval between pulses.
Blood flow rate	Perturbation of respiratory cycle	Blood photosensor	The user may be instructed to hold his/her breath. The level of blood oxygen falls after the less oxygenated blood has reached the measurement point, and rises again after a breath is taken and the more oxygenated blood arrives

1. A personal hand-held monitor (PHHM) which comprises a signal acquisition device for acquiring signals which can be used to derive a measurement of a subject's blood pressure (BP), the signal acquisition device being integrated with a personal hand-held computing device (PHHCD), wherein the signal acquisition device comprises a blood flow occlusion means adapted to be pressed against one side only of a body part or to have one side only of a body part pressed against it, a means for measuring the pressure applied by or to the body part, and a means for detecting the flow of blood through the body part in contact with the blood flow occlusion

means, wherein the blood flow occlusion means comprises at least part of an external surface of the PHHM wherein the pressure is sensed by means of a flexible and essentially incompressible gel in which is immersed a pressure sensor which is adapted to provide electrical signals to the processor of the PHHCD.

2. The PHHM of claim 1, wherein the essentially incompressible gel is a fluid covered by a flexible membrane forming some or all of the external surface.

3. A PHHM adapted to provide a BP measurement comprising:

a housing, the housing including a blood flow occlusion means in the form of an open surface against which, in use, a subject's body part can be pressed or which, in use, can be pressed against a subject's body part so that pressure can be applied to the subject's body part to occlude an artery in the body part;

a pressure sensor associated with the open surface for providing an electrical signal related to the pressure exerted by the open surface on the body part or vice versa; and

processing means for controlling the device and for receiving and analysing the electrical signals from the pressure measuring means to provide a measurement of the subject's systolic blood pressure (SBP) and/or diastolic blood pressure (DBP).

4. A PHHM comprising a signal acquisition device for acquiring signals which can be used to derive a measurement of a parameter related to the health of the user, the signal acquisition device being integrated with a PHHCD, wherein the parameter is BP and the signal acquisition device comprises a blood flow occlusion means adapted to be pressed against one side only of a body part or to have one side only of a body part pressed against it, a means for measuring the pressure applied by or to the body part, and a means for detecting the flow of blood through the body part in contact with the blood flow occlusion means, wherein the blood flow occlusion means comprises a button which is at least a part of an external surface of the PHHM which is saddle-shaped.

5. The PHHM of claim 4, where the button comprises a part of the saddle-shaped surface that is able to move independently of the remainder of the surface.

6. The PHHM of claim 5, wherein the button is co-planar with the remainder of the surface.

7. The PHHM of claim 6, wherein the button is covered by a thin continuous membrane to exclude contaminants.

8. The PHHM of claim 4, wherein the button comprises the whole of the saddle-shaped surface.

9. The PHHM of any one of claims 4 to 8, wherein the saddle-shaped external surface is continuous and sealed.

10. The PHHM of any one of claims 4 to 9, wherein the pressure sensor comprises a force-responsive device connected to the button.

11. The PHHM of any one of claims 4 to 10, wherein the distance the button moves when subject to interaction with a body part, such as a finger, is no more than approximately 0.01 mm.

12. A PHHM adapted to provide a BP measurement comprising:

a housing, the housing including a blood flow occlusion means in the form of an open surface against which, in use, a subject's body part can be pressed or which, in use, can be pressed against a subject's body part so that pressure can be applied to the subject's body part to occlude an artery in the body part;

a pressure sensor located in the open surface for providing an electrical signal related to the pressure exerted by the open surface on the body part or vice versa;

an optical sensor associated with the open surface for providing an electrical signal related to the luminal area of the artery which, in use, is occluded by the open surface; and

processing means for controlling the device and for receiving and analysing the electrical signals from the pressure

sensor and the optical sensor to provide a measurement of the subject's SBP and/or DBP.

13. The PHHM of claim 1, claim 3 or claim 12, wherein the blood flow occlusion means is saddle-shaped.

14. The PHHM of any one of claim 3 to 13, wherein the pressure sensor comprises a sealed vessel containing an essentially incompressible fluid in which is immersed a pressure sensing device which is adapted to provide electrical signals to the processing means or the processor of the PHHCD.

15. The PHHM of any one of claim 1 to 14, which is arranged to act as a tonometer.

16. The PHHM of claim 15, which is adapted to calibrate the tonometer by use of occlusion measurements obtained from the pressure sensor when used to occlude an artery.

17. The PHHM of any one of claims 1, 4 and 12 or any claim dependent thereon, wherein the means for detecting the flow of blood through the body part comprises a blood photosensor having one or more photo-emitters for transmitting light to a body part of a user and one or more photo-detectors for detecting light transmitted through or scattered by the body part, wherein the or each photo-emitter and/or the or each photo-detector is/are provided with one or more lenses to narrow the field of view.

18. The PHHM of any one of claims 1, 4 and 12 or any claim dependent thereon, wherein the means for detecting the flow of blood through the body part comprises a blood photosensor having one or more photo-emitters for transmitting light to a body part of a user and one or more photo-detectors for detecting light transmitted through or scattered by the body part, wherein there are either two photo-emitters or two photo-detectors arranged such that light emitted in two different directions can be detected, and the processing means of the processor of the PHHCD is adapted to process the signals received from each direction to locate a blood vessel in the user's body.

19. The PHHM of claim 18, which is adapted to provide a visible or audible signal to the user to move a body part to optimise the position of the photo-sensor with respect to the blood vessel.

20. The PHHM of claim 18 or claim 19, which is adapted to compensate the signals from the photo-detector(s) when the blood vessel is not optimally positioned with respect to the photo-sensor.

21. The PHHM of any one of claims 17 to 20, wherein the optical axes of the photo-emitter(s) and photo-detector(s) are aligned: to maximise the sensitivity of the signal produced by the photo-detectors to absorption of the emitted light by blood; and/or to minimise the sensitivity of the signal produced by the photo-detectors to the location of the blood vessel; and/or to optimise the performance of the personal hand-held monitor.

22. The PHHM of claim 1 or claim 4 or any claim dependent thereon, wherein the PHHM also serves as the on/off switch or some other user-operated control for the PHHCD.

23. The PHHM of any one of claims 1, 4 and 12 or any claim dependent thereon, wherein the processing means or the processor of the PHHCD is adapted to correlate the signals received from the pressure sensor with the signals received from the means for detecting the flow of blood or the optical sensor so that the pressure exerted between the occlusion means and the body part is correlated with the luminal area of the artery and to fit the correlated values to a curve to provide measurements of the subject's SBP and/or DBP.

24. The PHHM of any one of claims 1 to 23, which includes an electrical sensor for providing an electrical signal related to the time at which an electrical signal which initiates a heartbeat in the subject occurs.

25. The PHHM of any one of claims 1 to 24, which is of such a size and weight that it can readily be manipulated by a subject using one hand to hold the device against a part of the subject's body to make a measurement or by a medical practitioner holding the device against the subject.

26. The PHHM of any one of claims 1 to 25, wherein the occlusion means is sized so that it can interact with a subject's finger.

27. The PHHM of any one of claims 1 to 26, wherein the occlusion means is a concave area in one face of the PHHM.

28. The PHHM of claim 27, wherein the concave area is part-circular and has a width of from 5 to 10 mm and a depth at its deepest of from 2 to 4 mm.

29. The PHHM of any one of claims 1 to 28, which includes a plurality of pressure-responsive or force-responsive devices.

30. The PHHM of any one of claims 1 to 30, wherein the processing means or the processor of the PHHCD is adapted to provide audible or visual instructions, advantageously via a display means, if present, to the user to enable the user to use the device optimally.

31. The PHHM of claim 30, wherein the processing means or the processor of the PHHCD is adapted so that the instructions are interactive and based on signals received from the sensor(s) which can be used to determine whether the device is in the best position or being used correctly.

32. A PHHM according to claim 1 or claim 4 or any claim dependent thereon, wherein the PHHCD is a computer pointing device, commonly referred to as a mouse, or a remote controller for a television or other electronic equipment.

33. The PHHM of claim 32, wherein the PHHM communicates with the computer with which the pointing device is being used or another PHHCD by means of a cable or by means of a wireless connection.

34. A PHHM which comprises a signal acquisition device for acquiring signals which can be used to derive a measurement of a subject's BP, the signal acquisition device being integrated with a PHHCD, wherein the signal acquisition device comprises a blood flow occlusion means adapted to be pressed against one side only of a body part or to have one side only of a body part pressed against it, a means for measuring the pressure applied by or to the body part, a means for detecting the flow of blood through the body part in contact with the blood flow occlusion means, wherein the blood flow occlusion means and its associated electronic components are included in a weight for producing a force between the blood flow occlusion means and the body part by acceleration of the weight.

35. The PHHM of claim 34, wherein the blood flow occlusion means is adapted to communicate with the PHHCD by means of a cable or wirelessly.

36. The PHHM of claim 34 or claim 35, wherein the weight is adapted to be fitted such that acceleration arises from natural movements of the body part.

37. The PHHM of any one of claims 34 to 36, wherein the weight is adapted to be fitted such that acceleration arises from deliberate actions of the subject in response to visual or audible instructions from the PHHCD with which the PHHM communicates.

38. The PHHM of any one of claims 1 to 39, which is adapted to estimate the height of the PHHM with respect to a fixed point on the subject's body.

39. The PHHM of claim 38, wherein the fixed point is the subject's eyes and the PHHM is adapted to analyse an image of the subject's face obtained from a camera in a PHHCD to detect the eyes and a measure of the tilt angle of the PHHCD obtained from tilt sensors incorporated within the PHHCD.

40. The PHHM of any one of claims 1 to 39, wherein the PHHM is used to provide a binary or continuously variable means for the subject to enter data to the PHHCD in order to control some function of the PHHCD other than the measurements that are made by the PHHM.

41. A PHHM comprising a signal acquisition device for acquiring signals which can be used to derive measurements of one or more parameters related to the health of the user, wherein the signal acquisition device comprises a blood flow occlusion means adapted to be pressed against one side only of a body part or to have one side only of a body part pressed against it, a means for measuring the pressure applied by or to the body part, and a means for detecting the luminal area of an artery within the body part in contact with the blood flow occlusion means and wherein the PHHM is of such a size and weight that it can readily be manipulated by a subject using one hand to hold the device against a part of the subject's body to make a measurement or by a medical practitioner holding the device against the subject.

42. The PHHM of claim 41, which is adapted to be connected to a dedicated computing module.

43. The PHHM of claim 41, which is integrated with a PHHCD.

44. The PHHM of claim 43, wherein the PHHCD is a games controller, a computer pointing device (usually referred to as a mouse) or remote controller for a television or other electronic equipment.

45. The PHHM of any one of claims 41 to 44, wherein the blood flow occlusion means comprises an open surface which is at least a part of an external surface of the device and which is saddle-shaped with a central flat region and is sized so that it can interact with a subject's finger.

46. The PHHM of any one of claims 41 to 44, wherein the body part is the wrist and the open surface is domed with a central flat region.

47. The PHHM of any one of claims 41 to 46, which includes a means for locating the artery and the PHHM is adapted to process the signals from the pressure sensing means to locate the artery and/or to confirm the correct location of the artery.

48. The PHHM of any one of claims 41 to 47, wherein the PHHM is adapted to estimate the luminal area by the oscillometric method.

49. The PHHM of any one of claims 41 to 48, which is arranged to act as a tonometer.

50. The PHHM of claim 49, wherein the PHHM is adapted to calibrate the tonometer by use of occlusion measurements obtained from the pressure sensor when used to occlude an artery.

51. The PHHM of any one of claims 1 to 50, which includes a body temperature sensor which is a bolometer.

52. The PHHM of claim 51, wherein the temperature of the cold junction of the bolometer is measured using the same sensor as is used to measure the temperature of the pressure sensing means and/or an integrated circuit within the PHHM.

53. The PPHM of claim **51** or claim **52**, wherein the field of view of the bolometer is displayed on a screen of a PPHCD superimposed on an image derived from a camera of the PPHCD.

54. The PPHM of any of claims **1**, **4**, **34**, **39**, **43** and **53** or any claim dependent thereon, which is adapted to use other sensors incorporated within the PPHCD to detect if the PPHCD has been agitated in the period before the measurement and hence to warn the user of possible errors in blood pressure measurement or to prevent such measurements until the PPHCD has been essentially at rest for sufficient time.

55. The PPHM of any one of claim **1** to claim **54**, which is adapted to provide audible or visual instructions requesting the user to adopt two or more phases of operation, the first of which is used to measure the approximate values of SBP and DBP and/or to check that the user's body part is correctly located and/or at a suitable temperature, the second of which is used to make measurements of the said SBP and DBP and the subsequent phases (if any) are used to refine those measurements.

56. The PPHM of claim **55**, wherein the processing means is adapted so that the instructions are interactive and based on signals received from the sensor(s) which can be used to determine whether the device is in the best position or being used correctly.

57. The PPHM of any of claims **1** to **56**, wherein the PPHM has a unique identifier that may be read by the associated processing means.

58. The PPHM of claim **57**, wherein the sensors are calibrated on manufacture and the calibration data for each device associated with its unique identifier so that they may be downloaded to the device via the interne.

59. A PPHM comprising an optical sensor and optionally an electrical sensor, which PPHM is adapted to make an estimate of the rate and depth of respiration by analysing some or all of: the interval between heart beats independently from each of the signals of the optical means and from the signal from an electrical sensor (if fitted), the variations of the mean amplitude and peak to peak amplitude of the signal from the optical means, the amplitude of the signal from the electrical sensor (if fitted) and the variations of the phase difference between the signal from the optical means and the signal from the electrical sensor (if fitted), optionally making a quality assessment of each of those signals and combining them, optionally with a weighting based on the quality assessments.

60. A module comprising a housing, an occlusion means, a pressure sensor, optionally an optical sensor, optionally at least one of the electrodes of an electrical sensor and connections for electrically connecting those components to the remainder of a PPHM according to any one of claims **1** to **59** to form a connected device.

61. A module comprising a housing, an occlusion means, a pressure sensor, optionally an optical sensor, optionally at least one of the electrodes of an electrical sensor and connections for mechanically and electrically connecting those components to the remainder of a PPHM according to any one of claims **1** to **59** to form an integrated device.

62. The PPHM of any one of claims **1**, **4**, **12**, **34** and **41** or any claim dependent thereon, wherein the means for detecting the flow of blood through the body part or the luminal area of an artery comprises a blood photosensor having one or more photo-emitters for transmitting light to a body part of a user, wherein the light is green.

* * * * *

专利名称(译)	个人健康数据收集		
公开(公告)号	US20150374249A1	公开(公告)日	2015-12-31
申请号	US14/767444	申请日	2014-02-13
[标]申请(专利权)人(译)	LEMAN MICRO DEVICES		
申请(专利权)人(译)	LÉMANMICRO DEVICES SA		
当前申请(专利权)人(译)	LÉMANMICRO DEVICES SA		
[标]发明人	ELLIOTT CHRISTOPHER JONES MARK ERIC NAGOGA MIKHALL GAWAD SHADY KLEIN GABRIEL		
发明人	ELLIOTT, CHRISTOPHER JONES, MARK-ERIC NAGOGA, MIKHALL GAWAD, SHADY KLEIN, GABRIEL		
IPC分类号	A61B5/022 A61B5/00 A61B5/026		
CPC分类号	A61B5/14532 A61B2562/0238 A61B5/02233 A61B5/0261 A61B5/489 A61B5/6897 A61B5/6898 A61B5/7405 A61B5/742 A61B2560/0425 A61B5/1455 A61B5/14546 A61B5/0245 A61B5/02427 A61B5/0205 A61B5/14557		
优先权	2013002548 2013-02-13 GB 2013016914 2013-09-23 GB 2013016915 2013-09-23 GB		
外部链接	Espacenet USPTO		

摘要(译)

本公开提供了一种个人手持式监视器 (PHHM) , 其包括用于获取信号的信号采集装置, 该信号可用于导出对象的血压 (BP) 的测量, 该信号采集装置与个人手持式集成。计算设备 (PHHCD) 。信号采集装置包括血流阻塞装置, 该血流阻塞装置适于仅压在身体部位的一侧或仅使身体部分的一侧压在身体部位的一侧, 用于测量由身体部分施加或施加到身体部分的压力的装置, 和用于检测血液流过与血流阻塞装置接触的身体部分的装置。血流阻塞装置包括PHHM的外表面的至少一部分, 并且其中通过柔性且基本上不可压缩的凝胶来感测压力, 其中浸没有压力传感器。压力传感器适于向PHHCD的处理器提供电信号。

