



(19) **United States**
(12) **Patent Application Publication**
ISLAM

(10) **Pub. No.: US 2014/0371555 A1**
(43) **Pub. Date: Dec. 18, 2014**

(54) **SYSTEM AND METHOD FOR VOICE CONTROL OF MEDICAL DEVICES**

(60) Provisional application No. 60/408,025, filed on Sep. 3, 2002.

(71) Applicant: **Omni MedSci, Inc.**, Ann Arbor, MI (US)

Publication Classification

(72) Inventor: **Mohammed N. ISLAM**, Ann Arbor, MI (US)

(51) **Int. Cl.**
A61B 5/00 (2006.01)
A61B 5/024 (2006.01)
A61B 5/021 (2006.01)
A61B 5/1455 (2006.01)

(21) Appl. No.: **14/476,082**

(52) **U.S. Cl.**
CPC *A61B 5/0075* (2013.01); *A61B 5/14551* (2013.01); *A61B 5/024* (2013.01); *A61B 5/021* (2013.01); *A61B 5/0022* (2013.01); *A61B 5/742* (2013.01); *A61B 5/749* (2013.01)
USPC **600/323**; 600/476; 600/479; 600/480

(22) Filed: **Sep. 3, 2014**

Related U.S. Application Data

(60) Continuation of application No. 14/186,814, filed on Feb. 21, 2014, which is a continuation of application No. 13/913,678, filed on Jun. 10, 2013, now Pat. No. 8,848,282, which is a continuation of application No. 13/531,853, filed on Jun. 25, 2012, now Pat. No. 8,679,011, which is a continuation of application No. 13/349,244, filed on Jan. 12, 2012, now Pat. No. 8,472,108, which is a continuation of application No. 13/078,547, filed on Apr. 1, 2011, which is a division of application No. 12/625,253, filed on Nov. 24, 2009, now Pat. No. 8,098,423, which is a division of application No. 12/206,432, filed on Sep. 8, 2008, now Pat. No. 7,633,673, which is a division of application No. 10/812,608, filed on Mar. 30, 2004, now Pat. No. 7,433,116, which is a continuation of application No. 10/757,341, filed on Jan. 13, 2004, now Pat. No. 7,259,906, which is a continuation of application No. 10/652,276, filed on Aug. 29, 2003, now abandoned.

(57) **ABSTRACT**

A diagnostic system includes a plurality of semiconductor diodes, a multiplexer, and one or more waveguide structures to form an output beam. A lens system communicates some of the output beam onto a part of a user's body comprising blood to perform a measurement. A software application is capable of generating data based at least in part on the measurement, and it operates on a control system that may have a touch-screen, a proximity sensor, and a wireless transceiver to transmit wireless data over a wireless link. A host comprises a digital file, control logic at the host to process at least the portion of the wireless data to generate a status of the user, a memory storage device for recording the status, and an output for communicating at least a portion of the status or associated information over a communication link to one or more remote display output devices.

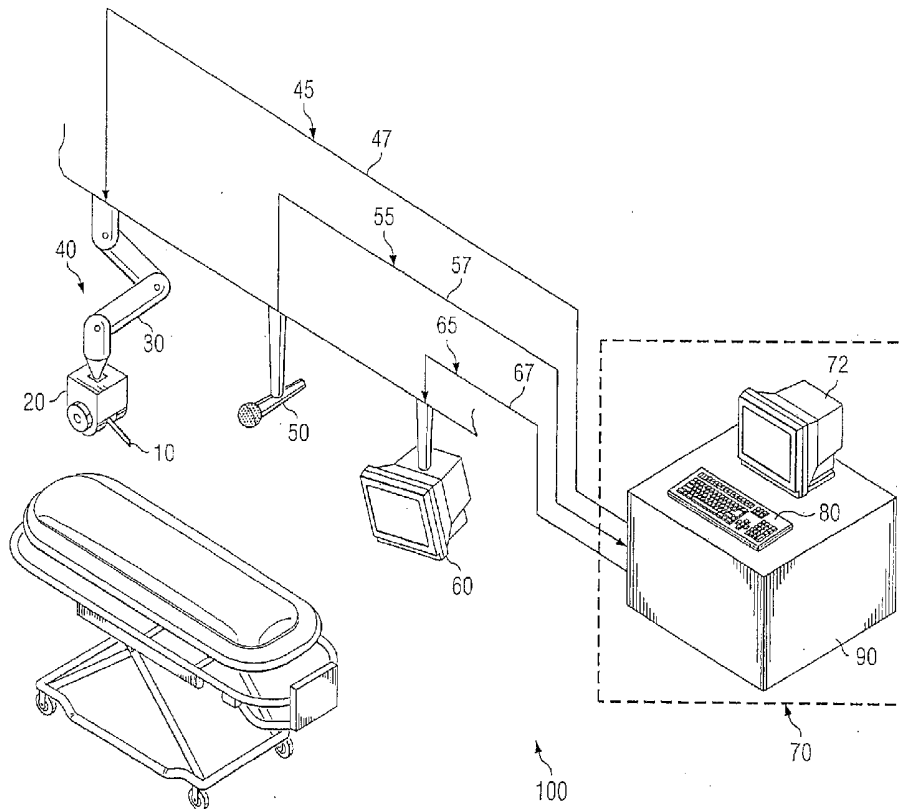

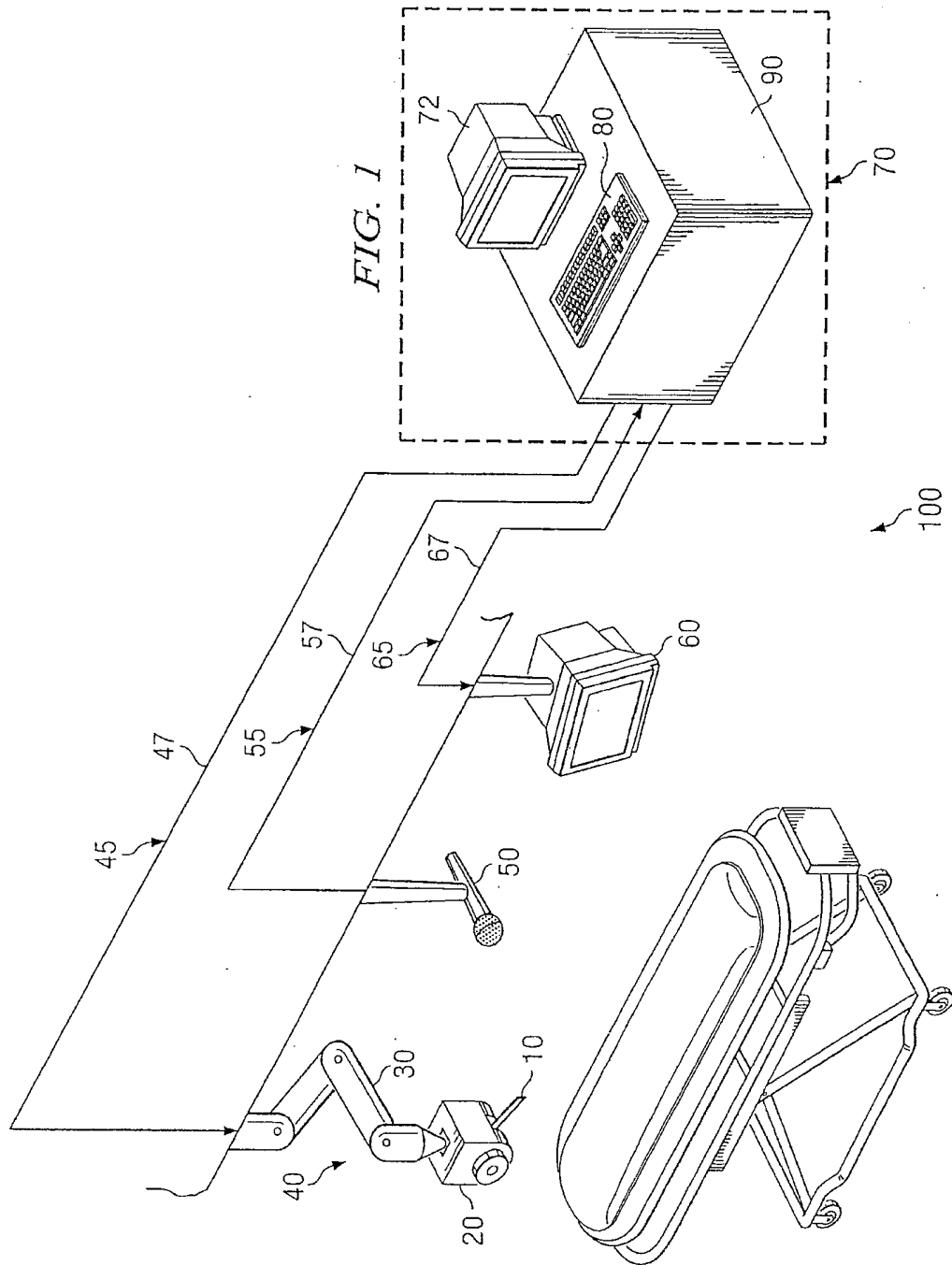

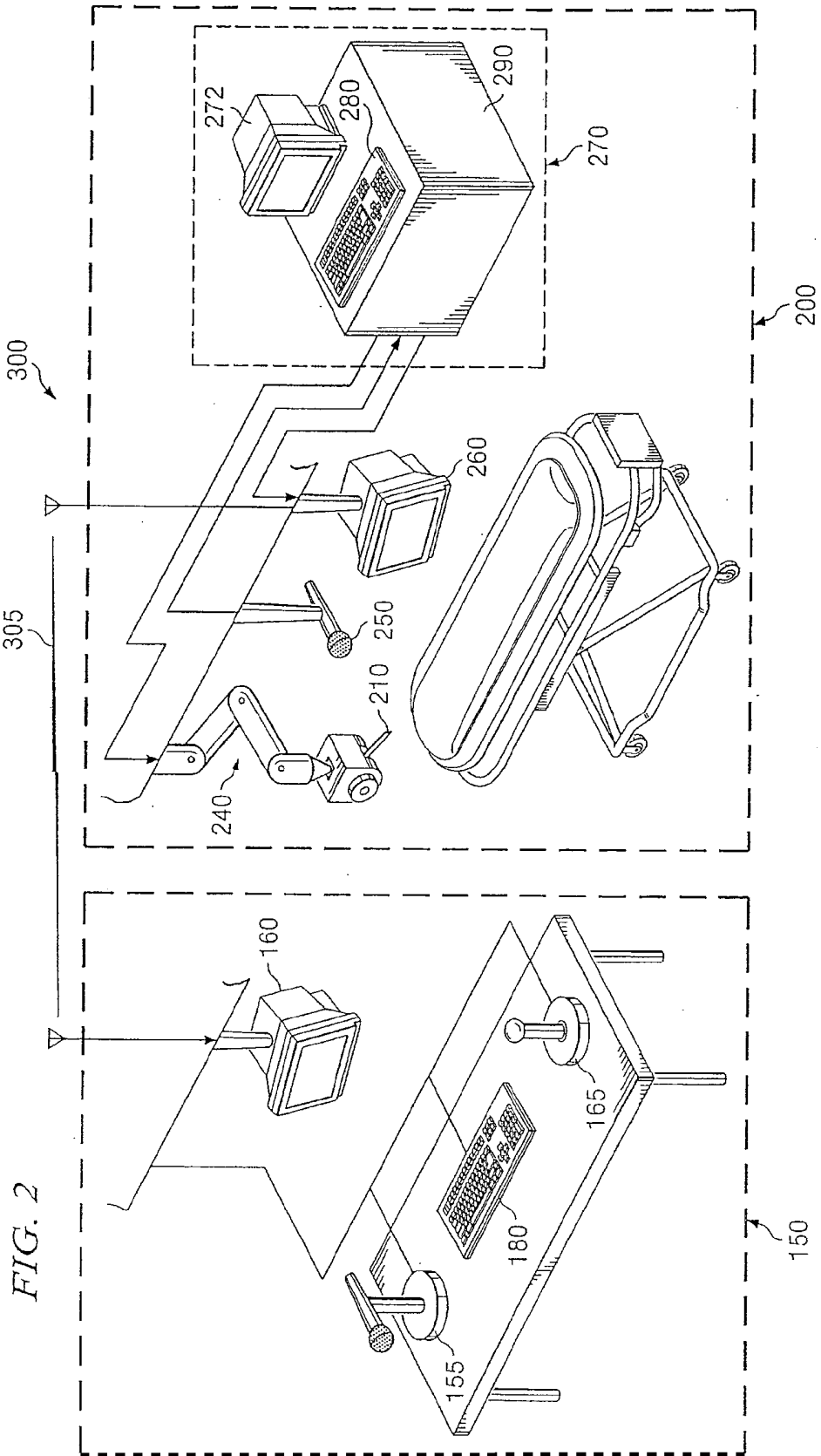

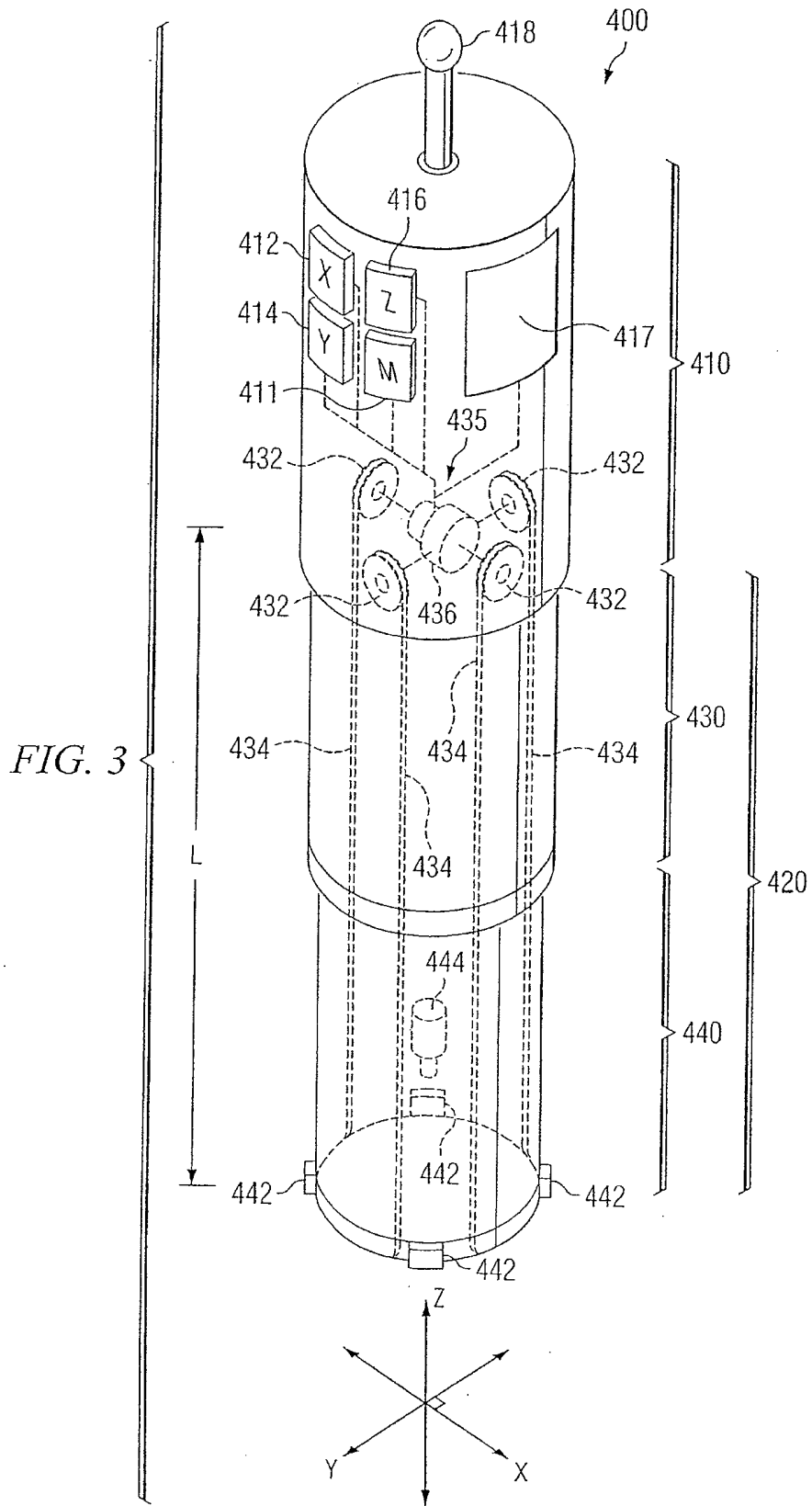

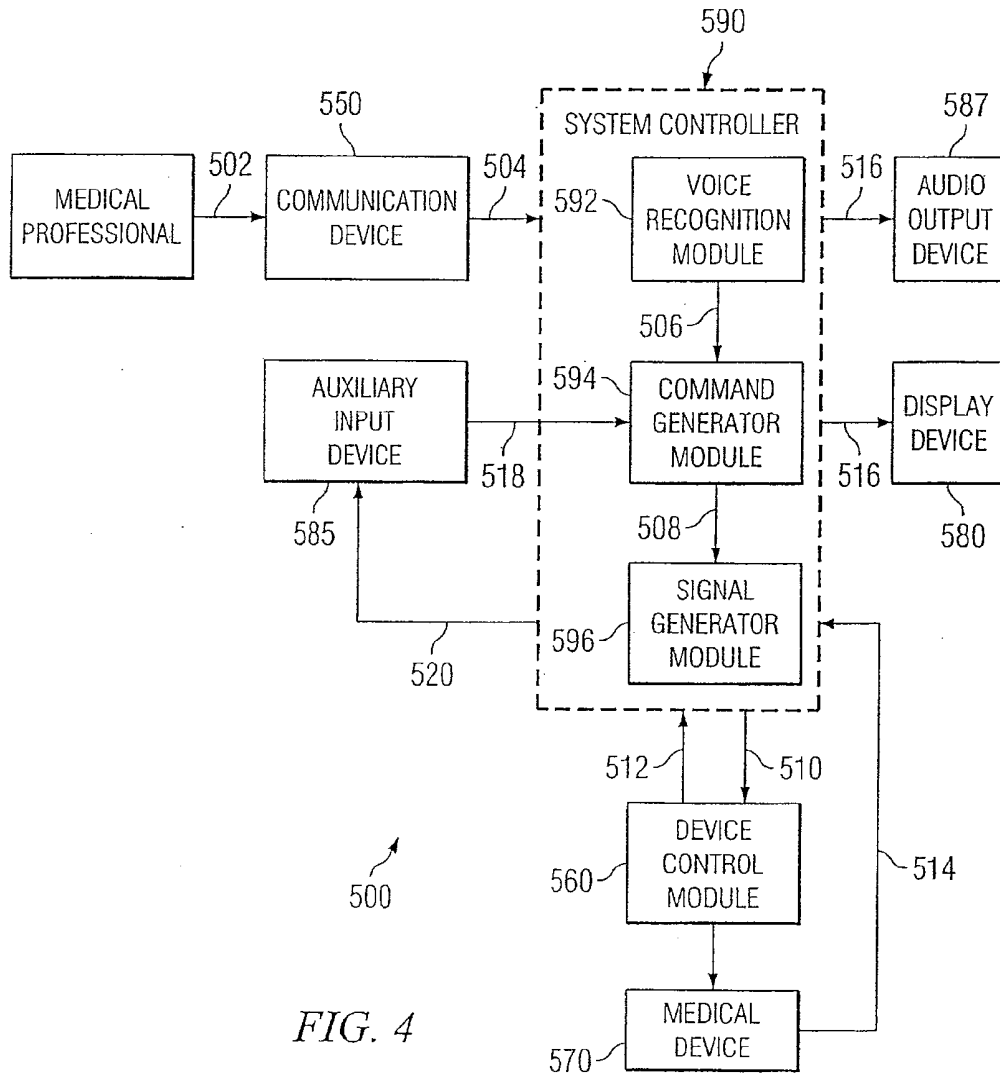

FIG. 4

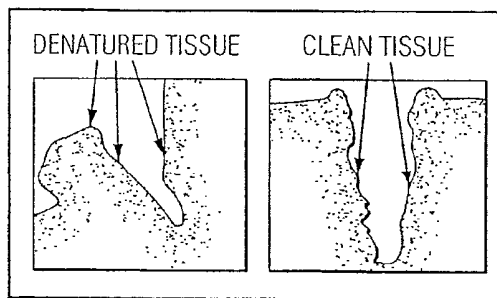

FIG. 6A

FIG. 5

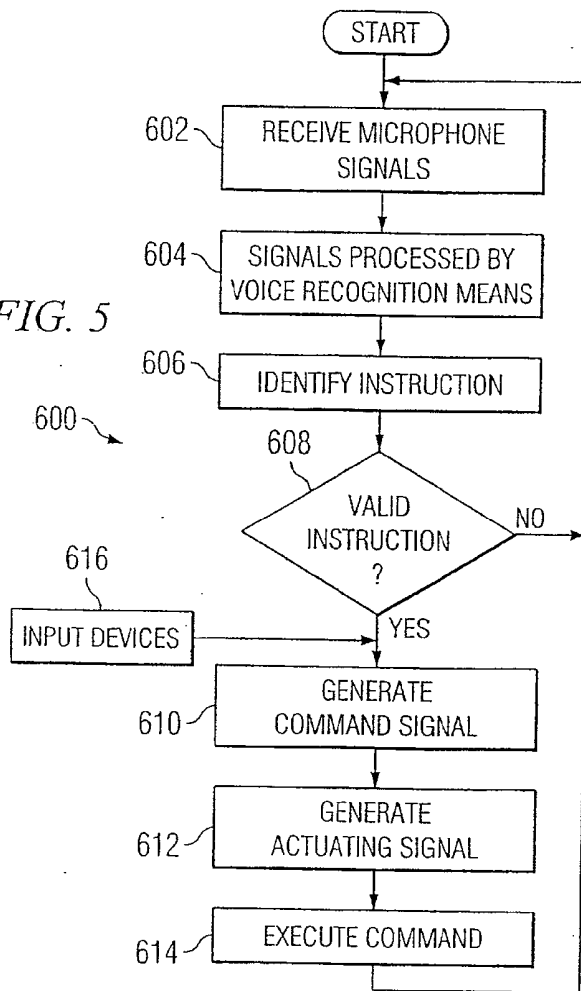
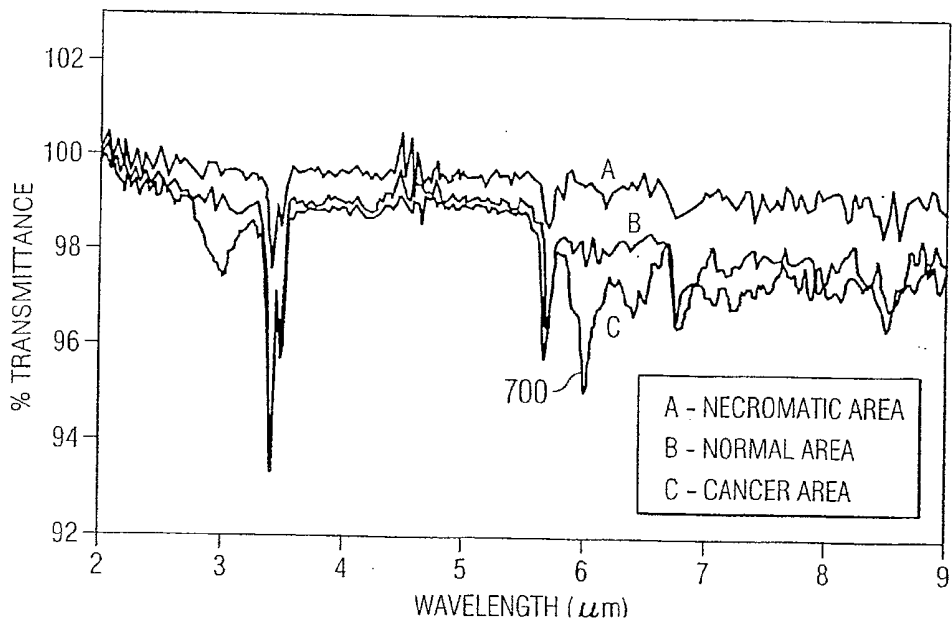

FIG. 6B



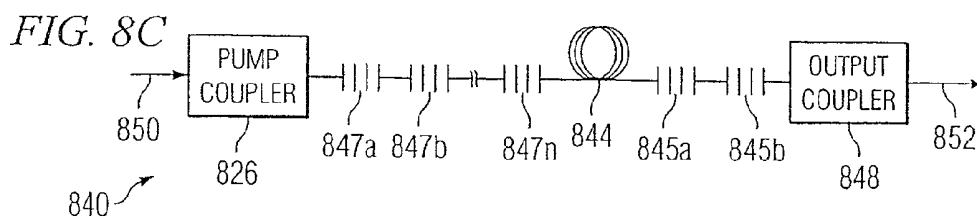
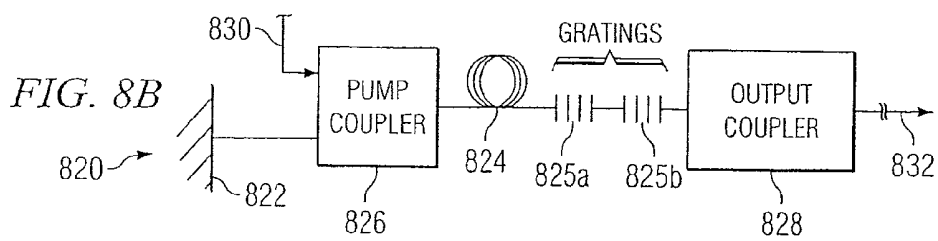
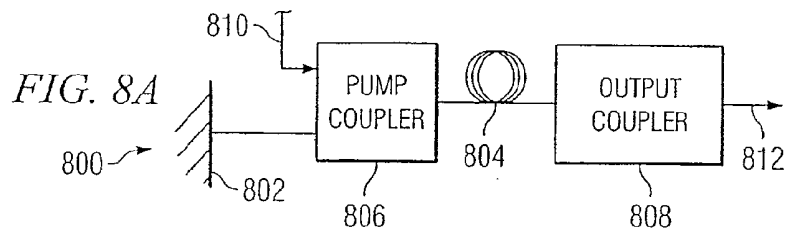
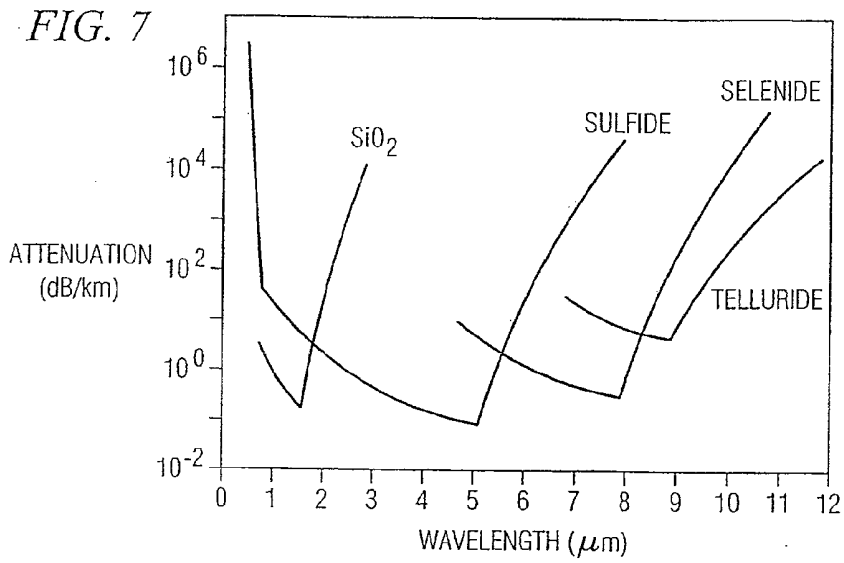

FIG. 8D

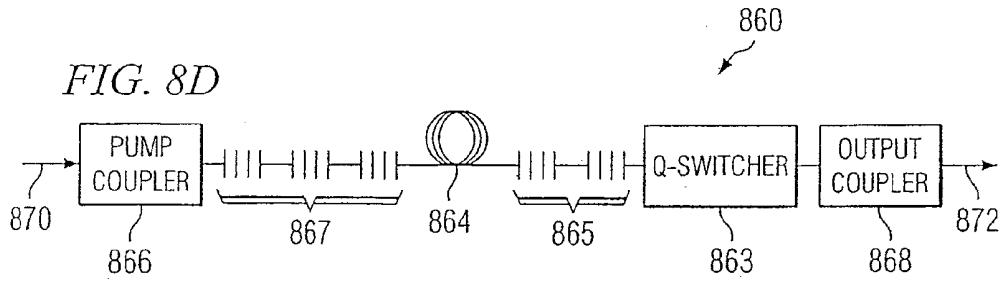

FIG. 9A

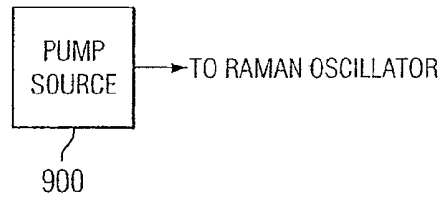

FIG. 9B

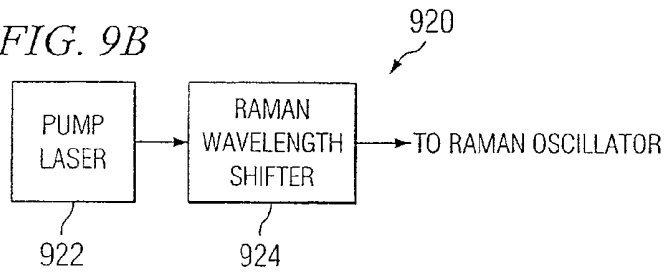
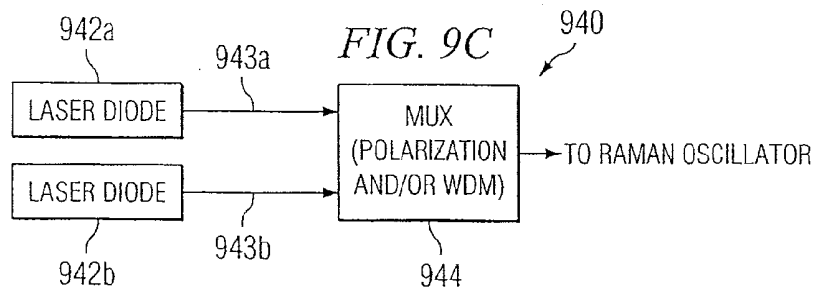

FIG. 9C



SYSTEM AND METHOD FOR VOICE CONTROL OF MEDICAL DEVICES

CROSS-REFERENCE TO RELATED APPLICATIONS

[0001] This application is a continuation of U.S. patent application Ser. No. 14/186,814 filed Feb. 21, 2014, which is a continuation of U.S. patent application Ser. No. 13/913,678 filed Jun. 10, 2013, which is a continuation of U.S. patent application Ser. No. 13/531,853 filed Jun. 25, 2012, which is a continuation of U.S. patent application Ser. No. 13/349,244 filed Jan. 12, 2012 (now U.S. Pat. No. 8,472,108 issued Jun. 25, 2013), which is a continuation of U.S. application Ser. No. 13/078,547 filed Apr. 1, 2011, which is a divisional of U.S. patent application Ser. No. 12/625,253 filed Nov. 24, 2009, now U.S. Pat. No. 8,098,423, issued Jan. 17, 2012, which is a divisional of U.S. patent application Ser. No. 12/206,432, filed Sep. 8, 2008, now U.S. Pat. No. 7,633,673, issued Dec. 15, 2009, which is a divisional of U.S. patent application Ser. No. 10/812,608, filed Mar. 30, 2004, now U.S. Pat. No. 7,433,116, issued Oct. 7, 2008, which is a continuation of U.S. patent application Ser. No. 10/757,341, filed Jan. 13, 2004, now U.S. Pat. No. 7,259,906, issued Aug. 21, 2007, which is a continuation of U.S. patent application Ser. No. 10/652,276 filed Aug. 29, 2003, abandoned. Application Ser. No. 10/652,276 claims the benefit to U.S. Provisional Patent Application No. 60/408,025 filed Sep. 3, 2002, the disclosures of which are incorporated in their entirety by reference herein.

TECHNICAL FIELD

[0002] This invention relates generally to medical devices and more particularly to a system and method for voice control of medical devices.

OVERVIEW

[0003] Medical procedures typically use medical instruments or devices that tend to require a high level of manual dexterity on the part of medical professionals. To achieve this high level of dexterity, medical professionals require years of training and practice. This high level of dexterity and the strain imposed on the medical professional when using those instruments can cause the medical professional to become fatigued during medical procedures. For example, certain medical instruments require the medical professional to use both hands and to stand next to the patient, sometimes in an awkward position through the entire procedure. This can create fatigue, thereby limiting the number of procedures that the medical professional is able to perform in a given period. In addition, the high level of fatigue may lead to unnecessary and dangerous errors occurring during medical procedures.

SUMMARY OF EXAMPLE EMBODIMENTS

[0004] In one embodiment, a light-based medical diagnostic system includes a pump source comprising a plurality of semiconductor diodes with pump beams, a multiplexer capable of combining the plurality of semiconductor diode pump beams and generating at least a multiplexed pump beam comprising one or more wavelengths, a first waveguide structure configured to receive at least a portion of the one or more wavelengths, wherein the first waveguide structure comprises at least in part a gain fiber and outputs a first optical beam, and a second waveguide structure configured to receive at least a portion of the first optical beam and to communicate

at least the portion of the first optical beam to an output end of the second waveguide structure to form an output beam, wherein at least a portion of the output beam comprises at least one wavelength in the range of 1.7 microns or more. A lens system is configured to receive at least the portion of the output beam and to communicate at least the portion of the output beam through a patient's mouth onto a part of a patient's body comprising a patient's blood. In various embodiments, at least the portion of the output beam is adapted for use in medical diagnostics to measure a property of the patient's blood, wherein the medical diagnostics comprise a spectroscopic procedure comprising a differential measurement, wherein the differential measurement is based at least in part on a comparison of amplitudes at a plurality of associated wavelengths transmitted or reflected from the patient's blood.

[0005] In another embodiment, a light-based diagnostic system includes a pump source comprising a plurality of semiconductor diodes with pump beams, a multiplexer capable of combining the plurality of semiconductor diode pump beams and generating at least a multiplexed pump beam comprising one or more wavelengths, first and second waveguide structures, and a lens system. The first waveguide structure is configured to receive at least a portion of the one or more wavelengths, wherein the first waveguide structure comprises at least in part a fused silica fiber, and outputs a first optical beam. The second waveguide structure is configured to receive at least a portion of the first optical beam and to communicate at least the portion of the first optical beam to an output end of the second waveguide structure to form an output beam. The lens system is configured to receive at least a portion of the output beam and to communicate at least the portion of the output beam through an orifice in a patient's body. In various embodiments, at least the portion of the output beam is adapted for use in multi-wavelength diagnostics to measure a property of a part of the patient's body, wherein the multi-wavelength diagnostics comprise a spectroscopic procedure comprising a differential measurement, wherein the differential measurement is based at least in part on a comparison of amplitudes at a plurality of associated wavelengths transmitted or reflected from the part of the patient's body.

[0006] In yet another embodiment, a light-based medical diagnostic system includes a pump source comprising a plurality of semiconductor diodes with pump beams and a multiplexer capable of combining the plurality of semiconductor diode pump beams and generating at least a multiplexed pump beam comprising one or more wavelengths. A first waveguide structure is configured to receive at least a portion of the one or more wavelengths, wherein the first waveguide structure comprises at least in part a fused silica fiber, and outputs a first optical beam. A second waveguide structure is configured to receive at least a portion of the first optical beam and to communicate at least the portion of the first optical beam to an output end of the second waveguide structure to form an output beam. A lens system is configured to receive at least a portion of the output beam and to communicate at least the portion of the output beam onto a part of a patient's body comprising a patient's blood.

[0007] In one embodiment, a medical device comprises an insertable portion capable of being inserted into an orifice associated with a body of a patient. The insertable portion comprising an automated head unit capable of being manipulated in at least two axes of motion based at least in part on one

or more control signals. The medical device further comprises one or more controllers coupled to the automated head unit. In one particular embodiment, the one or more controllers generate the one or more control signals based at least in part on an input signal.

[0008] In another embodiment, a medical device capable of minimizing tissue damage comprises an insertable portion capable of being inserted into an orifice associated with a body of a patient. The medical device further comprises one or more sensors coupled to the insertable portion. The one or more sensors capable of generating a feedback signal capable of being used to substantially minimize damage to tissue associated with the patient.

[0009] In yet another embodiment, a medical device capable of being used in a medical procedure comprises a pump laser capable of generating a pump signal. The medical device further comprises a Raman wavelength shifter coupled to the pump laser, at least a portion of the wavelength shifter comprising a waveguide structure. In one particular embodiment, the Raman wavelength shifter generates an output optical signal comprising a wavelength of approximately 1.7 microns or more.

[0010] In still another embodiment, a medical device capable of being used in a medical procedure comprises a Raman wavelength shifter operable to generate an optical signal comprising a mid-infrared wavelength. At least a portion of the Raman wavelength shifter comprises a chalcogenide waveguide.

[0011] In another embodiment, a system for controlling a medical device includes a monitor capable of communicating medical information associated with a patient and a communication device capable of receiving one or more input signals from a user. In one particular embodiment, the one or more input signals are based at least in part on the medical information displayed on the monitor. The system further includes one or more processors coupled to the communicated device and operable to convert the one or more input signals into one or more control signals capable of being used to manipulate a medical device.

[0012] Depending on the specific features implemented, particular embodiments may exhibit some, none, or all of the following technical advantages. Various embodiments may be capable of reducing medical professional fatigue through the implementation of a control system capable of manipulating a medical device through voice commands. Some embodiments may be capable of controlling a medical device from a remote location. Other embodiments may be capable of reducing the level of dexterity required of a medical professional when performing a medical procedure.

[0013] Other technical advantages will be readily apparent to one skilled in the art from the following figures, description, and claims. Moreover, while specific advantages have been enumerated, various embodiments may include all, some, or none of the enumerated advantages.

BRIEF DESCRIPTION OF THE DRAWINGS

[0014] To provide a more complete understanding of the present invention and certain features and advantages, thereof, reference is made to the following description taken in conjunction with the accompanying drawings, in which:

[0015] FIG. 1 illustrates one example embodiment of a medical device control system;

[0016] FIG. 2 illustrates another example embodiment of a medical device control system;

[0017] FIG. 3 illustrates an example medical device capable of being inserted into a patient's body during a medical procedure;

[0018] FIG. 4 is a block diagram illustrating a flow of command signals from a medical professional to a medical device in a medical device control system;

[0019] FIG. 5 is a flow chart illustrating an exemplary method for processing a voice control signal and/or a command signal received by a medical device control system;

[0020] FIG. 6A compares a surgical incision made using a 2.94 micron optical signal wavelength to a surgical incision made using a 6.45 micron optical signal wavelength;

[0021] FIG. 6B illustrates example evanescent spectra in different cell-type regions;

[0022] FIG. 7 illustrates example attenuation characteristics of several optical fibers based on wavelength;

[0023] FIGS. 8A through 8D are block diagrams illustrating example embodiments of Raman wavelength shifters and/or Raman oscillators capable of shifting a pump signal to an output signal wavelength of 1.7 microns or more; and

[0024] FIGS. 9A through 9C are block diagrams illustrating example embodiments of pump sources that are capable of generating a pump signal for use in a Raman wavelength shifter.

DESCRIPTION OF EXAMPLE EMBODIMENTS

[0025] As required, detailed embodiments of the present invention are disclosed herein; however, it is to be understood that the disclosed embodiments are merely exemplary of the invention that may be embodied in various and alternative forms. The figures are not necessarily to scale; some features may be exaggerated or minimized to show details of particular components. Therefore, specific structural and functional details disclosed herein are not to be interpreted as limiting, but merely as a representative basis for teaching one skilled in the art to variously employ the present invention.

[0026] FIG. 1 illustrates one example embodiment of a medical device control system 100. In this example, system 100 includes a medical device 10, a manipulator 40, a microphone 50, a display device 60, and a host 70. In various embodiments, system 100 may be capable of receiving voice commands associated with the manipulation of medical device 10 from a medical professional, such as a nurse, a medical assistant, a medical technician, and/or a doctor. In some cases, system 100 is capable of assisting a medical professional during a medical procedure by processing data signals associated with one or more voice commands and manipulating medical device 10 in response to those commands.

[0027] Medical device 10 may comprise any device or instrument that a medical professional needs to perform a medical procedure. Medical device 10 can comprise, for example, a surgical scalpel, a scope, a laser, an imaging device, a microscope, or a combination of these or any other suitable device. As used throughout this document, the term "scope" refers to any medical device capable of entering a patient's body, such as endoscopes, colonoscopes, gastroscopes, enteroscopes, bronchoscopes, laryngoscopes, chole-dochoscopes, sigmoidoscopes, duodenoscopes, arthroscopies, cystoscopes, hysteroscopes, laparoscopes, or a combination of these or any other suitable device.

[0028] In one particular embodiment, medical device 10 comprises an endoscope. In those cases, the endoscope may comprise an insertable portion capable of being inserted

through an orifice associated with a patient. In other embodiments, the insertable portion may be capable of being guided through the patient's orifice, and capable of collecting biological samples from the patient for investigation. The orifice associated with the patient may comprise, for example, a throat, a mouth, a nasal passage, an orifice created by the medical professional, and/or any other suitable orifice. In some embodiments, medical device 10 may include a fiberoptic cable with a lens system at the end that is capable of sending images to a camera and/or a display device, such as display device 60.

[0029] In other embodiments, medical device 10 may comprise one or more sensors coupled to feedback control circuitry that is capable of minimizing collateral tissue damage during a medical procedure. In various embodiments, the one or more sensors and the control circuitry may be capable of providing positioning information to a medical professional and/or a controller, such as system controller 90. In other embodiments, the one or more sensors and the control circuitry may be capable of providing data associated with one or more physiological parameters associated with the patient to a medical professional and/or a controller. In some cases, the one or more sensors may be capable of detecting and/or alerting a medical professional or a controller when medical device 10 is in close proximity to and/or in contact with tissue. In other cases, the one or more sensors and the control circuitry may be capable of detecting when medical device 10 is in contact with tissue and capable of overriding control signals received by medical device 10.

[0030] In this example, manipulator 40 includes an actuation unit 20 and a supporting structure 30. Actuation unit 20 may house one or more control systems capable of receiving control signals and manipulating medical device 10 in response to those control signals. The one or more control systems may comprise, for example, a mechanical control system, an electrical control system, or a combination of these or any other control system. As used throughout this document, the phrase "mechanical control system" refers to a control system that at least partially includes mechanical components. In various embodiments, actuation unit 20 can implement a mechanical control system, such as a hydraulic system, pneumatic system, or a pulley guidewire system.

[0031] Supporting structure 30 may comprise a robotic arm, one or more pivoted links, multiple links connected together to move in a "scissor-like" manner, or any other structure capable of supporting and manipulating medical device 10. Although this example depicts manipulator 40 and medical device 10 as separate devices, manipulator 40 and medical device 10 can comprise a unitary medical apparatus capable of performing the desired functionalities without departing from the scope of the present disclosure. For example, manipulator 40 and medical device 10 can be combined to form a unitary medical apparatus, such as an endoscope, have an automated portion.

[0032] In some embodiments, a freedom of motion associated with manipulator 40 can have a resolution that substantially replicates the manual dexterity of a medical professional and/or a manual medical device used by the medical professional. In some cases, manipulator 40 may have a step size and/or angle of rotation step size that is substantially similar to the manual dexterity of a medical professional and/or a manual medical device used by the medical professional. For example, the number of degrees of manipulation freedom associated with medical device 10 can match the

number of degrees of manipulation freedom currently available on manual devices. That is, if a conventional manual device that has four degrees of freedom in the x-y plane, then the range of motion associated with manipulator 40 can include at least four degrees of freedom in the x-y plane. In some embodiments, manipulator 40 may include manual override controls that allow a medical professional to exercise manual control of medical device 10.

[0033] Manipulator 40 is coupled to host 70 through a first communication link 45. As used throughout this document, the term "couple" and or "coupled" refers to any direct or indirect communication between two or more elements, whether or not those elements are in physical contact with one another. In this example, first communication link 45 is operable to facilitate the communication of command/data signals 47 between manipulator 40 and host 70. Command/data signals 47 may comprise, for example, video signals from a video device coupled to medical device 10, data obtained by sensors coupled to medical device 10, or manipulation commands generated in response to voice commands, auxiliary input commands, and/or automated commands.

[0034] In this example, host 70 is capable of performing a desired communicating and/or computing functionality. For example, host 70 may be capable of at least partially contributing to the manipulation of medical device 10. In other embodiments, host 70 may be capable of collecting, entering, processing, storing, retrieving, amending, and/or dispatching medical data during a medical procedure. In operation, host 70 may execute with any of the well-known MS-DOS, PC-DOS, OS-2, MAC-OS, WINDOWS™, UNIX, or other appropriate operating systems. In some embodiments, host 70 may include a graphical user interface (GUI) 72 that enables a medical professional to display medical data and/or medical video associated with medical device 10. Host 70 may comprise, for example, a desktop computer, a laptop computer, a server computer, a personal digital assistant, and/or any other computing or communicating device or combination of devices.

[0035] In this example, host 70 includes system controller 90 capable of processing, collecting, storing, retrieving, and/or amending medical data and/or video during a medical procedure. System controller 90 may comprise one or more computers, an embedded microprocessor, or any other appropriate device or combination of devices capable of processing and/or generating voice command signals 47 and/or 57. In operation, system controller 90 may execute with any of the well-known MS-DOS, PC-DOS, OS-2, MAC-OS, WINDOWS™, UNIX, or other appropriate operating systems. In this embodiment, system controller 90 may implement voice recognition software operable to process voice command signals 57. For example, system controller 90 may implement one or more voice recognition software programs, such as ViaVoice or Dragon Speech Recognition software, or any appropriate proprietary or nonproprietary voice recognition software. In certain embodiments, the voice recognition software may be programmed to recognize the medical professional's voice and commands may be customized to the medical professional's preferences. In addition, the voice recognition software may be capable of filtering out background noise.

[0036] System controller 90 is operable to process voice command signals 57, generate command/data signals 47 in response to the voice command, and communicate the command/data signals 47 to manipulator 40. System controller 90

may also be used to collect and record data using a memory storage device. System controller **90** may be operable to provide data associated with a patient's medical status during a medical procedure to the medical professional using display device **60** and/or GUI **72**, or any other appropriate devices.

[0037] In this embodiment, host **70** also includes an auxiliary input device **80** coupled to system controller **90**. Although a keyboard is depicted in this example, any other device capable of inputting commands and/or data may be used without departing from the scope of this disclosure. In this example, auxiliary device **80** is operable to facilitate manual entry of manipulation commands to supplement and/or replace voice commands. In addition, the medical professional may use auxiliary device **80** to input data into system controller **90**, such as the patient's physiological parameters, for example, blood pressure, heart rate, blood oxygen level, or to retrieve data stored in a memory device associated with host **70**.

[0038] In this example, system **100** also includes display device **60** and a graphical user interface (GIU) **72**, each capable of displaying medical information, such as medical data and/or medical video. Display device **60** and GUI **72** may comprise, for example, a monitor, a LED, a heads-up display, virtual reality goggles, a closed circuit television, a CAVE environment, or any other device or combination of devices capable of displaying. In some cases, display device **60** and GUI **72** may display a live video image from a video device associated with medical device **10**, information about a patient's medical status, such as the current state of any number of the patient's physiological parameters, information about the particular medical device **10** being used, or any other information that may assist a medical professional during a medical procedure. In this example, display device **60** is coupled to host **70** through a third communication link **65**, which is operable to facilitate the communication of data signals **67** to and/or from host **70**.

[0039] In this example, system **100** also includes communication device **50** that enables a medical professional to communicate with host **70**. Communication device **50** can comprise any device that enables a medical professional to communicate with host **70**. Communication device **50** may comprise, for example, a telephone, a wireless device, a voice-over-IP device, a unidirectional microphone attached to a headset worn by a medical professional, a bi-directional microphone, or any other suitable communicating device or combination of devices. Communication device **50** may be selectively attached to and/or placed near the medical professional for ease of use. Attaching communication device **50** to the medical professional can, in some cases, advantageously minimize background noise. Although system **100** includes one communication device **50** in this example, any other number of communication devices may be used without departing from the scope of the present disclosure. Communication device **50** is coupled to host **70** through a second communication link **55**, which is operable to facilitate the communication of voice command signals **57** between communication device **50** and host **70**.

[0040] In the illustrated embodiment, system **100** includes at least a first communications link **45**, a second communications link **55**, and a third communications link **65** each operable to facilitate the communication of data to and/or from host **70**. Communications links **45**, **55**, and **65** may include any hardware, software, firmware, or combination thereof. In various embodiments, communications link **45**, **55**, and **65**

may comprise any communications medium capable of assisting in the communication of analog and/or digital signals. Communications links **45**, **55**, and **65** may, for example, comprise a twisted-pair copper telephone line, a fiber optic line, a Digital Subscriber Line (DSL), a wireless link, a USB bus, a PCI bus, an Ethernet interface, or any other suitable interface operable to assist in the communication of information to and/or from network **104**.

[0041] In conventional medical procedures involving a scope, a medical professional manually manipulates the medical device based on feedback from the medical device. The medical professional typically uses one hand to hold the medical device and guide it into and through a patient's body. The medical professional's other hand is used to manipulate the manual controls of the medical device. Thus, conventional systems typically require significant manual dexterity, which can result in a significant amount of strain on the medical professional.

[0042] Unlike conventional procedures, system **100** comprises a communication device **50** that enables a medical professional to manipulate medical device **10** using voice commands, auxiliary input commands, and/or automated commands. Allowing a medical professional to use voice commands and/or automated commands can significantly reduce the manual dexterity, and the resulting strain, imposed on the medical professional during a medical procedure.

[0043] In operation, a medical professional can speak voice commands into communication device **50** for communication to host **70**. Host **70** receives voice command signals **57** from communication device **50** and processes those signals using a voice recognition module associated with host **70**. Host **70** converts the voice command signals into command/data signals **47** and communicates signals **47** to manipulator **40**. Manipulator **40** responds by causing medical device **10** to perform its desired function. Voice commands may comprise, for example, a voice to take a photograph of a portion of the patient's body, a voice command to change an image size by zooming in or out, or any other suitable voice command capable of causing medical device **10** to perform its functionality. In other embodiments, host **70** is capable of automatically generating command/data signals **47** based at least in part on data received from medical device **10** through communication link **47**.

[0044] FIG. 2 illustrates another example embodiment of a medical device control system **300**. System **300** includes system **150** for remote manipulation of a medical device **210** and system **200** for voice control of medical device **210**. In this example, system **150** is capable of controlling at least a portion of system **200** from a remote location. For example, a medical professional may use system **150** to remotely control system **200** in the case where the medical professional is not located near system **200**. The remote location may comprise, for example, a different location in the hospital that includes system **200**, a location in a different hospital, or any other location.

[0045] System **150** can include a communication device **155**, a display device **160**, a first auxiliary input device **165**, and a second auxiliary input device **180**. The structure and function of communication device **155**, display device **160**, and second auxiliary input device **180** can be substantially similar to the structure and function of communication device **50**, display device **60**, and auxiliary input device **80**, respectively, of FIGURE I. First auxiliary input device **165** may comprise, for example, a joystick, a computer mouse, a roll-

erball, knobs, levers, buttons, touchpads, touchscreens, or any other appropriate control device capable of being used to control manipulator 240. In this example, a medical professional can use first auxiliary input device 165 to control manipulator 240 from the remote location.

[0046] In this embodiment, system 200 includes a medical device 210, a manipulator 240, a communication device 250, and a display device 260. System 200 also includes a host 270 comprising GUI 272, a third auxiliary input device 280, and a system controller 290. Although host 270 resides within system 200 in this example, host 270 could reside within system 150 or could reside in any location accessible to system 300 without departing from the scope of the present disclosure. The structure and function of medical device 210, manipulator 240, communication device 250, display device 260, host 270, GUI 272, third auxiliary input device 280, and system controller 290 can be substantially similar to the structure and function of medical device 10, manipulator 40, communication device 50, display device 60, host 70, GUI 72, auxiliary input device 80, and system controller 90, respectively, of FIG. 1.

[0047] System 150 communicates with system 200 over communication link 305. Although communication link 305 comprises a single communication link in this example, any other number of communication links may be used without departing from the scope of the present disclosure. Communications link 305 may include any hardware, software, firmware, or combination thereof. In various embodiments, communications link 305 may comprise a communications medium capable of assisting in the communication of analog and/or digital signals. Communications link 305 may, for example, comprise a twisted-pair copper telephone line, a fiber optic line, a Digital Subscriber Line (DSL), a wireless link, a USB bus, a PCI bus, an Ethernet interface, or a combination of these or other elements.

[0048] In some embodiments, a first medical professional can manually insert medical device 210 into a patient. In those cases, system 200 can communicate data to a second medical professional using remote system 150 through communication link 305. The second medical professional, while monitoring display device 160, can remotely manipulate medical device 210 using voice instructions communicated through communication device 155 coupled to communication link 305 to host 270. In this manner, the medical professional using system 150 can substantially emulate a medical professional's manual control of medical device 210. In other embodiments, the medical professional can remotely manipulate medical device 210 using auxiliary devices 165 and/or 180. In an alternative embodiment, a medical professional can insert medical device 210 into a patient using system 200 locally or using system 150 remotely.

[0049] In addition to voice command control and/or auxiliary input device control, other methods of medical device control may be implemented. In some cases, system 150 and/or system 200 can implement a heads-up-display (HUD) capable of controlling and/or manipulating medical device 210 and/or manipulator 240. The HUD may be capable of projecting images onto or near the eyes of a medical professional and capable of sending command signals using a virtual control device attached to the medical professional. In another example, the medical professional may wear a helmet capable of manipulating medical device 210 and/or manipulator 240 based at least in part on command signals generated in response to a motion associated with the head of the medi-

cal professional. For example, rotation of the head to the right may indicate that the operator wants the medical device to move to the right.

[0050] FIG. 3 illustrates an example medical device 400. In various embodiments, at least a portion of medical device 400 may be inserted into a patient's body through an orifice during a medical procedure. The orifice may comprise, for example, the patient's throat or mouth, the patient's nasal passages, an incision made during surgery, or any other suitable orifice. In this particular example, medical device 400 comprises a scope. The scope may comprise, for example, an endoscope, a colonoscope, a gastroscope, an enteroscope, a bronchoscope, a laryngoscope, a choledochoscope, a sigmoidoscope, a duodenoscope, an arthroscope, a cystoscope, a hysteroscope, a laparoscope, or a combination of these or any other suitable device. In various embodiments, medical device 400 can be controlled through, for example, voice commands, auxiliary input command, automated commands, and/or manual commands. In some cases, medical device 400 can be coupled to a medical device control system, such as system 100 or system 300 of FIG. 1 and FIG. 2, respectively.

[0051] Medical device 400 includes a base portion 410 capable of controlling and/or at least partially contributing to the manipulation of an insertable portion 420. In this example, base portion 410 includes control system 435 capable of at least partially contributing to the control and/or the manipulation of insertable portion 420. Control system 435 may be capable of receiving, processing, executing, and/or communicating one or more signals associated with the manipulation of insertable portion 420. In various embodiments, these signals received by base portion 410 may comprise, for example, voice commands, auxiliary input commands, automated commands, physiological parameters, video data, positioning data, or a combination of these or other signal types.

[0052] In various embodiments, control system 435 may reside in a location outside of base portion 410 and/or may be partially or wholly included within base portion 410. Control systems 435 may comprise, for example, a mechanical control system, an electrical control system, an electro-mechanical control system, or a combination of these or any other suitable control system. The phrase "mechanical control system" refers to a control system that at least partially includes mechanical components. Mechanical control systems can include, for example, hydraulic components, pneumatic components, pulleys, guidewires, gears, actuators, pushrods, sprocket/chain mechanisms, feedback control circuitry, or any other suitable components.

[0053] In this particular embodiment, control system 435 includes a manual override control module 411, an x-axis control module 412, a y-axis control module 414, and a z-axis control module 416. Control modules 411, 412, 414, and 416 may include any hardware, software, firmware, or combination thereof. In some embodiments, control modules 411, 412, 414, and 416 may comprise buttons, knobs, dials, control circuitry, or any other suitable control input device. In this particular embodiment, control modules 412, 414, and 416 operate to receive and process input signals from a medical professional. In addition, control modules 412, 414, and 416 operate to at least partially contribute to the manipulation of insertable portion 420. The input signals may comprise, for example, voice commands, auxiliary input commands, and/or manual input commands. In other embodiments, control modules 412, 414, and 416 operate to receive and process

input signals from a host and/or system controller. For example, a medical professional can use control modules 412, 414, and 416 to individually control medical device 400 in the x-, y-, and z-axes, respectively. In various embodiments, override control module 411 may be capable of enabling the medical professional to override the automatic operation of medical device 400 as necessary during a medical procedure.

[0054] Control system 435 may also include touch-screen 417 and controller 418. Controller 418 operates to combine the individual control functions of control modules 412, 414, and 416 into a single controller. For example, a medical professional can use controller 418 and/or touchscreen 417 to manually control medical device 400 in the x-, y-, and z-axes, respectively. Controller 418 can comprise any device capable of controlling the manipulation of insertable portion 420. Controller can comprise, for example, a joystick, a rollerball, knobs, levers, buttons, or any other appropriate control device.

[0055] Control system 435 further includes motors 436, pulleys 432, and guidewires 434. Although motors, pulleys, and guidewires are used in this example, control system 435 can include any other components capable of contributing to the manipulation of insertable portion 420 without departing from the scope of the present disclosure. In this example, motors 436 operate to control the positioning of insertable portion 420 based at least in part on control signals received from modules 411, 412, 414, and 416, and/or controller 418. Motors 436 operate to manipulate guidewires 434 coupled to one end of insertable portion 420. In other embodiments, base unit 410 includes actuators, pushrods, sprocket/chain mechanisms, feedback control circuitry, or any other control mechanism appropriate to control insertable portion 420.

[0056] In this example, pulleys 432 and motors 436 operate to control the tension in guidewires 434. In some embodiments, each guidewire 434 may comprise two or more segments, each segment comprising a different radial stiffness. For example, a first segment of guidewire 434 may be coupled to pulley 432, and a second segment of guidewire 434 may be coupled to an end of insertable portion 420. In that example, the second segment of guidewire segment may have a radial stiffness that is less than a radial stiffness associated with the first segment guidewire. In various embodiments, the force exerted by guidewires 434 can cause insertable portion 430 to move in a corresponding manner.

[0057] Medical device 400 may also include insertable portion 420 connected to base portion 410 and capable of being inserted into an orifice or incision in a patient's body during a medical procedure. In this particular embodiment, a medical professional can, using base portion 410, manipulate insertable portion 420 in the patient's body to perform a medical procedure. In various embodiments, a medical professional can control insertable portion 420 using voice commands, auxiliary input commands, automated commands, and/or manually.

[0058] In this example, insertable portion 420 includes a flexible portion 430 and an automated head unit 440. In this particular embodiment, one end of each guidewire 434 is connected to one end of automated head unit 440, while the other end of each guidewire 434 is connected to one of pulleys 432. Although pulleys and guidewires are used to manipulate automated head unit 440, any other appropriate control mechanism may be used without departing from the scope of the present disclosure. In this example, control system 435

operates to create tension in guidewires 434. The tension in guidewires 434 operates to exert a force on automated head unit 440, which causes automated head unit 440 to move in a corresponding manner. For example, control system 435 may operate to apply tension to one or more guidewires 434 creating a force in the x-plane, which causes automated head unit 440 to move in the x-plane. Any suitable movement of automated head unit 440 in the x-y plane tends to impart a corresponding movement to flexible portion 430 in the x-y plane.

[0059] In this example, four guidewires 434 are used to manipulate automated head unit 440 with two guidewires 434 connected along the x-axis and two guidewires 434 connected along the y-axis. In an alternative embodiment, six or more guidewires 434 may be positioned around the periphery of the insertable portion 420, which can allow a medical professional more precise control of medical device 400. In some cases, the movement of automated head unit 440 may be controlled independently of the movement of flexible portion 430. In some embodiments, flexible portion 430 and automated head unit 440 may operate as "telescoping" tubes, where automated head unit 440 may retract into and extend from flexible portion 430 to adjust a length (L) of insertable portion 420. Such a telescoping motion may be controlled through the positioning of pulleys 432 and guidewires 434.

[0060] In this particular embodiment, control modules 412, 414, and/or 416 receive and process command signals corresponding to a desired manipulation of insertable portion 420. Control module 412 and control module 414 are operable to control the motion of automated head unit 440 and the entire insertable portion 420 in the x-axis and y-axis, respectively. In some embodiments, control module 416 is operable to adjust the distance that automated head unit 440 moves relative to flexible portion 430. In those cases, control module 416 is operable to cause motor 436 to position the pulleys 432 and guidewires 434 so as to extend and retract automated head unit 440 relative to flexible portion 430. Control module 412 and control module 414 are operable to independently control the motion of automated head unit 440 regardless of length L, enabling insertable portion 420 to have independent motion in the x-, y-, and z-axes.

[0061] Insertable portion 420 may also include sensors 442 and a camera 444. Although this example depicts sensors 442 as being connected to automated head unit 440, sensors may be connected to any portion of medical device 400 without departing from the scope of the present disclosure. Injury may occur when a medical professional accidentally or mistakenly causes insertable portion 420 to contact tissue associated with the patient, which can cause bruising or damage to the tissue. Sensors 442 can comprise any device capable of providing data and/or a signal to a medical professional. Sensors 442 may be capable of generating and transmitting, for example, positioning information associated with insertable portion 420, physiological information associated with the patient, control signals, a signal indicating the presence or absence of blood, or any other data. In one particular embodiment, sensors 442 are capable of generating and transmitting data associated with insertable portion's 420 proximity to tissue of the patient.

[0062] In other embodiments, sensors 442 may be capable of detecting a collision with tissue. In those cases, sensors 442 are capable of generating and transmitting a feedback signal to control modules 412, 414, 416, a host coupled to medical device 400, or a system controller coupled to medical device 400. For example, sensors 442 may communicate data indi-

ating that wall tissue of a patient's orifice has been encountered and that device 400 may need to be directed away from that wall to prevent injury to the patient's tissue. In some embodiments, sensors 442 operate to generate alarms associated with medical device 400. For example, one or more sensors 442 may monitor the presence of blood in the orifice, so that the medical professional may be alerted to unexpected or excessive bleeding.

[0063] In operation, medical device 400 may be inserted into the patient by inserting insertable portion 420 into the appropriate orifice or incision. In some embodiments, a medical professional can insert medical device 400 into the patient. In other embodiments, the insertion of medical device 400 into the patient may be performed using a medical device control system implementing a manipulator, such as system 100 and manipulator 40 of FIG. 1 or system 300 and manipulator 240 of FIG. 2.

[0064] In this particular embodiment, medical device 400 is capable of being manipulated in at least three axes of motion. That is, medical device 400 is capable of being manipulated in the x-axis, y-axis, and z-axis. In other embodiments, medical device 400 is capable of being manipulated in at least two axes of motion. In some embodiments, medical device 400 may be capable of manipulating insertable portion 420 one axis at a time. In other embodiments, medical device 400 may be capable of manipulating insertable portion 420 one axis at a time and manipulating insertable portion 420 along multiple axes substantially simultaneously. In this example, medical device 400 is capable of manipulating insertable portion 420 along multiple axes substantially simultaneously. As used throughout this document, the phrase, "substantially simultaneously" refers to the manipulation of insertable portion 420 and/or automated head unit 440 in multiple axes in response to an input command before responding to a subsequent input command. For example, medical device 400 can manipulate insertable portion 420 along the z-axis and, during that manipulation, medical device 400 can also manipulate insertable portion 420 along the x-axis. In various embodiments, medical device 400 can manipulate automated head unit 440 independently of the movement of flexible portion 430.

[0065] FIG. 4 is a block diagram illustrating a flow of command signals from a medical professional to a medical device in a medical device control system 500. In various embodiments, medical device control system 500 can be substantially similar to control system 100 of FIG. 1 or control system 300 of FIG. 2. In this example, a communication device 550 receives a voice command 502 from a medical professional. In various embodiments, the structure and function of communication device 550 can be substantially similar to the structure and function of communication device 50 of FIG. 1. Communication device 550 operates to convert voice command 502 into an electrical voice command signal 504 and to communicate electrical voice command signal 504 to a system controller 590. In various embodiments, the structure and function of system controller 590 can be substantially similar to the structure and function of system controller 90 of FIG. 1.

[0066] In this particular embodiment, system controller 590 comprises a voice recognition module 592 capable of at least partially contributing to one or more functions of system controller 590. That is, voice control module 592 is not required to be capable of performing the desired functionality of system controller 590 alone, but may contribute to the

performance of the function as part of a larger routine. In this example, voice recognition module 592 at least partially contributes to the conversion of voice command signal 504 to a control signal 506. Voice recognition module 592 may include any hardware, software, firmware, or any combination thereof that is capable of converting voice command signal 504 into control signal 506.

[0067] System controller 590 also includes a command generator module 594 capable of at least partially contributing to one or more functions of system controller 590. In this example, command generator module 594 operates to receive control signal 506 communicated from voice recognition module 592 and at least partially contributes to the conversion of control signal 506 into a command signal 508. Command generator 594 may comprise any hardware, software, firmware, or any combination thereof that is capable of converting control signal 506 into command signal 508. In this example, command generator module 594 communicates command signal 508 to a signal generator module 596 capable of at least partially contributing to one or more functions of system controller 590. In this example, signal generator module 596 at least partially contributes to the conversion of command signal 508 into an actuation signal 510. Signal generator 596 may comprise any hardware, software, firmware, or any combination thereof that is capable of converting command signal 508 into actuation signal 510.

[0068] In this example, system controller 590 communicates actuation signal 510 to a device control module 560 capable of manipulating a medical device 570. In various embodiments, the structure and function of device control module 560 can be substantially similar to the structure and function of actuation unit 20 of FIG. 1 or base portion 410 of FIG. 3. In various embodiments, the structure and function of medical device 570 can also be substantially similar to the structure and function of medical device 10 of FIG. 1 or medical device 400 of FIG. 3.

[0069] In various embodiments, device control module 560 may be capable of generating a feedback signal 512 and communicating feedback signal 512 to system controller 590. Feedback signal 512 may comprise, for example, positioning data associated with medical device 570, a video feed, a physiological parameter associated with a patient, or any other information associated with medical device 570, device control module 560, and/or a patient undergoing a medical procedure. In some embodiments, medical device 570 can communicate data 514 to system controller 590. Data 514 may comprise, for example, positioning data, one or more physiological parameters associated with a patient, a live video feed associated with a camera coupled to medical device 570, or any other data capable of being collected by medical device 570.

[0070] In various embodiments, system controller 590 may be capable of generating commands on its own based at least in part on data 514 and/or feedback signal 512 communicated from medical device 570 and/or device control module 560. For example, if medical device 570 comprises a scope with blood sensors, system controller 590 may stop the movement of the scope within a patient's body if data 514 is received from medical device 570 indicating that the patient is bleeding excessively.

[0071] In this example, system 500 also includes a display device 580 capable of displaying data associated with medical device 570 and/or a patient. The structure and functional of display device 580 can be substantially similar to the

structure and function of display device 60 or GUI 72 of FIG. 1. Although system 500 includes a single display device in this example, any other number of display devices may be used without departing from the scope of the present disclosure. In some embodiments, system controller 590 can communicate an output signal 516 containing data associated with medical device 570 and/or a patient to display device 580.

[0072] In some embodiments, system 500 may also include an audio output device 587 capable of communicating data associated with medical device 570 and/or a patient. Audio output device 587 can comprise any device capable of providing an audio output signal, such as a speaker, headphones, an audio alarm device, or any other suitable audio output device. Although system 500 includes a single audio output device in this example, any other number of audio output devices may be used without departing from the scope of the present disclosure. In some embodiments, system controller 590 may communicate an audio output signal 516 to output device 587 so that the medical professional may receive the data associated with output signal 516 in audio format.

[0073] Although, in most cases, voice command 502 represents the primary control input into system 500, system 500 also includes an auxiliary input device 585 capable of generating a control signal 518. Control signal 518 can comprise data that is substantially similar to data contained within control signal 506. In various embodiments, the structure and function of auxiliary input device 585 can be substantially similar to the structure and function of auxiliary input devices 165 or 180 of FIG. 2. Although system 500 includes a single auxiliary input device in this example, any other number of auxiliary input devices may be used without departing from the scope of the present disclosure. In this particular embodiment, auxiliary input device 585 is coupled directly to command generator 594. In some embodiments, auxiliary input device 585 may also receive data signals 520 from system controller 590. For example, in a case where auxiliary input device 585 comprises a "force-feedback" joystick, signals 520 may comprise the feedback signal representing the force being exerted on medical device 570 by the patient's body.

[0074] FIG. 5 is a flow chart illustrating an exemplary method 600 for processing a voice control signal and/or a command signal received by a medical device control system. In one particular embodiment, voice control signals and/or command signals are received from system 100 of FIGURE I. Although system 100 is used in this example, any other system, such as systems 300 and 500 of FIGS. 2 and 4, respectively, may be used without departing from the scope of the present disclosure.

[0075] In this example, method 600 begins at step 602 where communication device 50 receives a voice command from a medical professional. Communication device 50 operates to convert the voice command into voice command signal 57 and communicates voice command signal 57 to host 70. In this particular example, host 70 includes a voice recognition module that processes voice command signal 57 at step 604 by converting voice command signal 57 into a control signal. In various embodiments, the structure and function of the voice recognition module can be substantially similar to voice recognition module 592 of FIG. 4. In this example, the voice recognition module further operates to identify the specific voice command represented by the control signal at step 606. In some embodiments, identifying the specific voice command may be accomplished by comparing the received con-

trol signal with a list of pre-programmed commands stored in a memory device associated with host 70.

[0076] The voice recognition module validates the control signal at step 608. If the voice command is not recognized as a pre-programmed command, the invalid voice command is ignored and the method loops back to step 602. If the voice command is valid, the voice recognition module communicates the control signal to a command generator. In this example, the command generator operates to convert the control signal into a command signal representing the voice command at step 610. In various embodiments, the structure and function of the command generator can be substantially similar to the structure and function of command generator module 594 of FIG. 4.

[0077] In an alternate embodiment, auxiliary control signals capable of manipulating a medical device may be generated by an auxiliary input device at step 616. In various embodiments, the auxiliary input device may comprise, for example, auxiliary input devices 165 and/or 180 of FIG. 2. The auxiliary input device communicates the auxiliary control signal to the command generator, which converts the auxiliary control signal into a command signal at step 610. The command generator also operates to communicate the command signal to a signal generator.

[0078] In this example, the signal generator operates to convert the command signal into an actuation signal 47 representing the voice command of the medical professional at step 612. In various embodiments, the structure and function of the signal generator can be substantially similar to the structure and function of signal generator module 596 of FIG. 4. In this example, manipulator 40 and/or medical device 10 operates to receive and execute actuation signal 47 at step 614.

[0079] Medical devices, such as a scope, that are adapted to be inserted into the patient's body typically permit the introduction of a waveguide structure or other wired device through the patient's orifice. The waveguide structure can comprise, for example, an optical fiber, a hollow tube waveguide, an air core waveguide, a planar waveguide, or a combination of these or other devices. Examples of such additional devices include, for example, surgical knives, sample collectors, and/or cauterizing heads. In some cases, inserting a waveguide structure may enable, for example, the early detection of cancerous cells and may contribute to the removal of the cancerous cells. In various embodiments, the waveguide structure may communicate an optical signal wavelength of 1.7 microns or more.

[0080] In some embodiments, a waveguide structure may be implemented in a medical device that uses an optical signal wavelength in the mid-infrared (mid-IR) wavelength range to perform surgery and/or spectroscopy on a patient. In various embodiments, a wavelength in the mid-IR range comprises a wavelength between approximately two (2) microns and approximately ten (10) microns. In other embodiments, a wavelength in the mid-IR range comprises a wavelength between approximately five (5) and seven (7) microns. For light-based surgery and spectroscopy, it can be particularly advantageous to use an optical signal wavelength in the range between approximately 5 microns to approximately 7 microns to minimize tissue damage or collateral damage. In a particular embodiment, an optical signal having a wavelength of approximately 6.45 microns may be advantageously used for light-based surgery and/or spectroscopy.

[0081] In some embodiments, a Raman wavelength shifter coupled to a pump laser is capable of generating an optical signal wavelength in the mid-IR range. As used in this document, the phrase “Raman wavelength shifter” refers to any device that uses the Raman effect to shift a shorter optical signal wavelength to a longer optical signal wavelength. The Raman wavelength shifters may comprise, for example, one or more reflectors, one or more gratings, an optical fiber, or a combination of these or other elements. In various embodiments, the Raman wavelength shifter may comprise, for example, a chalcogenide glass fiber that is capable of shifting the shorter pump laser wavelength to a longer wavelength, such as a wavelength in the mid-IR region. The chalcogenide fiber may comprise, for example, a ZBLAN fiber, a sulphide fiber, a selenides fiber, or a telluride fiber, or a combination of these or other fiber types.

[0082] In other embodiments, a first wavelength shifter coupled to a pump laser may be capable of shifting an optical signal wavelength to approximately 2 microns. The first wavelength shifter may comprise, for example, a fused silica optical fiber capable of shifting the shorter pump laser wavelength to approximately two (2) microns. In that example, a second Raman wavelength shifter is coupled to the first Raman wavelength shifter and is capable of shifting the two (2) micron signal to a wavelength in the five (5) to seven (7) micron range. In that example, the second Raman wavelength shifter comprises a chalcogenide glass fiber.

[0083] FIG. 6A compares a surgical incision made using a 2.94 micron optical signal wavelength to a surgical incision made using a 6.45 micron optical signal wavelength. This figure illustrates that tissue damage, such as denatured tissue, can result when a medical device implements a 2.94 micron optical signal wavelength. This tissue damage tends to result from the protein temperatures in the tissue do not uniformly exceed the water temperature in the aqueous components of the tissue.

[0084] Compared to the incision performed using the 2.94 micron optical signal wavelength, the incision made using the 6.45 micron optical signal has little or no denatured tissue. This reduction in collateral tissue damage is based at least in part on the tissue’s ability to absorb differential energy. For example, when using an optical signal wavelength at approximately 6.45 microns to create an incision, the protein temperatures in the tissue uniformly exceed the water temperature in the tissue and the protein begins to transform into brittle denatured protein. The brittle fracture of the proteins at the onset of explosive vaporization leads to the confinement of collateral damage. Therefore, the use of a 6.45 micron optical signal wavelength as a tissue cutting implement may minimize collateral tissue damage during laser-based surgery. By using an optical signal wavelength of 6.45 microns with a medical scope-type device, “clean” surgery may be performed for many medical procedures, such as removing cancerous polyps. Similar results can be obtained using an optical signal wavelength in the five (5) to seven (7) micron range.

[0085] FIG. 6B illustrates example evanescent spectra in different cell-type regions (using a mouse as the biological sample). This figure illustrates that cancerous cells tend to show a distinct reduction **700** in transmission at an optical signal wavelength of approximately 6.1 microns. Medical professionals can exploit this spectral signature in various medical procedures, such as a procedure for the early detection of cancer. Thus, an optical signal wavelength in the

mid-IR range may be used to perform a medical procedure for the early detection of tissue abnormalities such as cancer cells. In other embodiments, an optical signal wavelength in the mid-IR range can be used in a diagnostic procedure, such as spectroscopy. Diagnostic techniques capable of using the mid-IR optical signal wavelength include, for example, transmission, reflection, fluorescence, and near field microscopy. Although specific examples of spectroscopy are discussed, any other appropriate form of spectroscopy may be used without departing from the scope of this disclosure.

[0086] To improve the signal-to-noise ratio of a spectroscopic measurement such as in FIG. 6B, several methodologies may be used. First, a differential measurement may be taken between a known cancer-free area and the suspect area, for example, differential spectroscopy rather than absolute spectroscopy. In addition, measurements may be taken at several wavelengths and compared to each other. For example, measuring the differential transmission of the tissue at two or more wavelengths, such as 5 microns and 6.1 microns, may improve the signal-to-noise ratio of the cancer cell signature.

[0087] FIG. 7 illustrates example attenuation characteristics of several optical fibers based on wavelength. This example shows that fused silica (SiO₂) fibers become lossy above approximately 2 microns in wavelength, while mid-IR optical fibers remain relatively loss-less above 2 microns. A mid-IR fiber may comprise any optical fiber capable of at least partially transmitting for at least a portion of the mid-IR range. For example, a mid-IR fiber may comprise a chalcogenide fiber, such as a sulfide fiber, a selenides fiber, or a telluride fiber. Therefore, in some cases, a pump source coupled to a medical device, such as medical device **400** of FIG. 3, may comprise a high powered pump source coupled to a Raman wavelength shifter comprising a mid-IR fiber. In a particular embodiment, such a pump source may operate in a pulsed mode or in a continuous wave mode. The power levels required depend on the particular application. For example, spectroscopy may require a relatively low power level, while surgery may require a relatively high power level.

[0088] Conventional surgical devices capable of using a 5.0 to 6.5 micron optical signal wavelength typically implement a Free Electron Laser (FEL) pump source. However, a FEL pump source is a large and very expensive facility that tends to be impractical for surgical applications. Unlike conventional surgical devices, a medical device, such as device **400** of FIG. 3, can include a pump laser coupled to one or more Raman wavelength shifters capable of shifting a shorter signal wavelength to a longer signal wavelength. In that example, at least a portion of the Raman wavelength shifter can be implemented in a waveguide structure. In various embodiments, the longer signal wavelength can comprise, for example, an optical signal wavelength in the mid-IR wavelength range. Coupling a pump laser to one or more Raman wavelength shifters can result in a commercially and economically viable optical cutting implement for use in a medical device. In addition, coupling a pump laser to one or more Raman wavelength shifters can result in a significantly smaller footprint area than a FEL pump source and can significantly reduce the cost.

[0089] Conventional wavelength shifters or oscillators are typically implemented in fused silica fiber. The loss associated with fused silica fiber tends to increase rapidly for optical signal wavelengths greater than about 2 or 2.3 microns. Unlike conventional wavelength shifters, a medical device,

such as device **400** of FIG. 3, can include a Raman wavelength shifter or oscillator that is capable of transmitting in the mid-IR wavelength range, such as chalcogenide optical fibers.

[0090] FIGS. 8A through 8D are block diagrams illustrating example embodiments of Raman wavelength shifters and/or Raman oscillators capable of shifting a shorter pump signal wavelength to a longer output signal wavelength. Although particular examples of wavelength shifters are described in FIGS. 8A through 8D, any other Raman wavelength shifter can be implemented without departing from the scope of the present disclosure.

[0091] FIG. 8A is a block diagram illustrating one example of a Raman wavelength shifter **800** capable of shifting a shorter pump signal **810** wavelength to a longer output signal wavelength **812**. In this example, Raman wavelength shifter **800** operates to generate an optical signal wavelength **812** of 1.7 microns or more. In various embodiments, Raman wavelength shifter **800** can operate to generate an optical signal wavelength **812** in the mid-IR wavelength range. In other embodiments, Raman wavelength shifter **800** can operate to generate an optical signal wavelength **812** a wavelength in the five (5) to seven (7) micron range. In various embodiments, pump signal **810** can comprise, for example, a 1310 nanometer (nm) wavelength, 1390 nm wavelength, 1510 nm wavelength, or other optical signal wavelength.

[0092] Raman wavelength shifter includes a gain fiber **804** operable to facilitate shifting pump signal **810** to a desired wavelength. Gain fiber **804** may comprise any waveguide structure capable of wavelength shifting pump signal **810** to a longer wavelength or a different Raman cascade order. In this particular embodiment, gain fiber **804** comprises an optical fiber. The optical fiber used as gain fiber **804** may comprise, for example, a dispersion compensating fiber, a dispersion shifter fiber, a single mode fiber, a chalcogenide fiber, a fused silica optical fiber, or a combination of these or other fiber types. Raman wavelength shifter **800** also includes a broadband reflector **802** operable to substantially reflect all optical signal wavelengths contained within Raman wavelength shifter **800** and a pump signal coupler **806**. Reflector **802** may comprise any device capable of reflecting a wide range of wavelength signals, such as a mirror. Pump signal coupler **806** may comprise any device capable of coupling pump signal **810** to Raman wavelength shifter **800**, such as a wavelength division multiplexer or a power coupler.

[0093] In this example, Raman wavelength shifter **800** further includes a wavelength separator **808** capable of transmitting at least a portion of the desired wavelength from Raman wavelength shifter **800**. In addition, wavelength separator **808** operates to at least partially reflect a desired wavelength to gain medium **804** to continue lasing at the desired wavelength or wavelengths. In this particular embodiment, a cavity is formed between reflector **802** and wavelength separator **808**. Separator **808** could comprise, for example, a demultiplexer, one or more partially transmissive gratings, one or more partially transmitting mirrors, one or more Fabry Perot filters, one or more dielectric gratings, or any combination of these or other devices.

[0094] FIG. 8B is a block diagram illustrating one example of a Raman wavelength shifter **820** capable of shifting a shorter pump signal **830** wavelength to a longer output signal wavelength **832**. In this example, Raman wavelength shifter **820** operates to generate an optical signal wavelength **832** of 1.7 microns or more. In various embodiments, Raman wave-

length shifter **820** operates to generate an optical signal wavelength **832** in the mid-IR wavelength range. In other embodiments, Raman wavelength shifter **820** operates to generate an optical signal wavelength **832** a wavelength in the five (5) to seven (7) micron range. In various embodiments, pump signal **830** can comprise, for example, a 1310 nanometer (nm) wavelength, 1390 nm wavelength, 1510 nm wavelength, or other optical signal wavelength.

[0095] In this example, Raman wavelength shifter **820** includes a reflector **822**, a gain fiber **824**, a pump input coupler **826**, and a wavelength separator **828**. In various embodiments, the structure and function of reflector **822**, gain fiber **824**, coupler **826**, and separator **828** can be substantially similar to reflector **802**, gain fiber **804**, coupler **806**, and separator **808** of FIG. 8A, respectively. In this particular embodiment, at least a portion of gain fiber **824** can comprise a chalcogenide fiber.

[0096] Raman wavelength shifter **820** may also include at least a first selecting element **825a** and a second selecting element **825b**. Although this example may also include two selecting elements **825a** and **825b**, any number of selecting elements can be used without departing from the scope of the present disclosure. Selecting elements **825a** and **825b** can comprise any device, such as a dielectric grating or one or more Fabry Perot filters. Each selecting element operates to transmit a portion of a desired wavelength to be output from Raman wavelength shifter **820**. In addition, each selecting element **825a** and **825b** operates to at least partially reflect a desired wavelength to gain medium **824** to allow wavelength shifter **820** to continue lasing at the desired wavelength or wavelengths. In this particular embodiment, an optical cavity is formed between reflector **822** and selecting element **825a** and/or selecting element **825b**.

[0097] FIG. 8C is a block diagram illustrating one example of a Raman wavelength shifter **840** capable of shifting a shorter pump signal **850** wavelength to a longer output signal wavelength **852**. In this example, Raman wavelength shifter **840** operates to generate an optical signal wavelength **852** of 1.7 microns or more. In various embodiments, Raman wavelength shifter **840** operates to generate an optical signal wavelength **852** in the mid-IR wavelength range. In other embodiments, Raman wavelength shifter **840** operates to generate an optical signal wavelength **852** a wavelength in the five (5) to seven (7) micron range. In various embodiments, pump signal **850** can comprise, for example, a 980 nanometer (nm) wavelength, a 1060 nm wavelength, a 1310 nm wavelength, a 1390 nm wavelength, a 1510 nm wavelength, or other optical signal wavelength.

[0098] In this example, Raman wavelength shifter **840** includes a gain fiber **844**, a pump input coupler **846**, and selecting elements **845**. In various embodiments, the structure and function of gain fiber **844**, coupler **826**, selecting elements **845**, and output coupler **848** can be substantially similar to gain fiber **824**, coupler **826**, selecting elements **825**, and coupler **828** of FIG. 8B, respectively. In this particular embodiment, at least a portion of gain fiber **824** can comprise a chalcogenide fiber.

[0099] The example illustrated in FIG. 8C differs from the example illustrated in FIG. 8B in that wavelength shifter **840** implements a plurality of reflective gratings **847a-847n** each centered on a different wavelength of a reflection band. Although this example includes three gratings, any number of gratings can be used without departing from the scope of the present disclosure. Gratings **847a-847n** can comprise any

device, such as a high-reflectivity dielectric grating. In this particular example, each grating **847a-847n** comprises a grating with a reflectivity between ninety-five (95) to one hundred (100) percent at the center wavelength. Gratings **847a-847n** operate to facilitate cascading of pump signal **850** to a desired output wavelength. In this particular embodiment, an optical cavity is formed between selecting elements **845** and gratings **847**.

[0100] FIG. 8D is a block diagram illustrating one example of a Raman wavelength shifter **860** capable of shifting a shorter pump signal **870** wavelength to a longer output signal wavelength **832**. In this example, Raman wavelength shifter **860** operates to generate an optical signal wavelength **872** of 1.7 microns or more. In various embodiments, Raman wavelength shifter **860** operates to generate an optical signal wavelength **872** in the mid-IR wavelength range. In other embodiments, Raman wavelength shifter **860** operates to generate an optical signal wavelength **872** a wavelength in the five (5) to seven (7) micron range. In various embodiments, pump signal **870** can comprise, for example, a 980 nm wavelength, a 1060 nm wavelength, a 1310 nm wavelength, a 1390 nm wavelength, a 1510 nm wavelength, or other optical signal wavelength.

[0101] In this example, Raman wavelength shifter **860** includes a gain fiber **864**, a pump input coupler **866**, selecting elements **864**, reflective gratings **867**, and an output coupler **868**. In various embodiments, the structure and function of gain fiber **864**, input coupler **866**, elements **864**, gratings **867**, and output coupler **868** can be substantially similar to gain fiber **844**, coupler **846**, elements **845**, gratings **847**, and coupler **848** of FIG. 8C, respectively. Although example elements are illustrated, Raman wavelength shifter **860** may include some, none, or all of these elements. For example, in some embodiments, pump input coupler **866** and/or output coupler **868** may be optional.

[0102] The example illustrated in FIG. 8D differs from the example illustrated in FIG. 8C in that wavelength shifter **860** implements a Q-switcher **863** capable of transitioning from a reflective state to a transmissive state. Q-switcher **863** can comprise a device or combination of devices having a variable loss. For example, Q-switcher may comprise one or more moving mirrors, electro-optic switches, saturable absorbers, or a combination of these or other optical devices. In some cases, Q-switcher **863** can initially operate as a reflective mirror so that optical signal energy may build-up within the laser cavity. After the laser cavity contains a sufficient amount of optical energy, Q-switcher **863** can operate to substantially transmit the desired optical signal wavelength in the form of a relatively large pulse or burst. In various embodiments, Q-switcher **863** may be capable of providing an output signal having a pulse width in the range of two (2) nanoseconds to one hundred (100) milliseconds. In other embodiments, Q-switcher **863** may be capable of providing an output signal having a pulse repetition rate in the range of two (2) hertz to one hundred (100) megahertz.

[0103] FIGS. 9A through 9C are block diagrams illustrating example embodiments of pump sources that are capable of generating a pump signal for use in a Raman wavelength shifter. Although particular examples of pump sources are described in FIGS. 9A through 9C, any other pump source can be implemented without departing from the scope of the present disclosure.

[0104] FIG. 9A is a block diagram illustrating one example embodiment of a pump source **900** capable of being coupled

to a Raman wavelength shifter and/or a Raman oscillator. Pump source **900** can comprise any device capable of generating an optical signal at a desired wavelength and power. For example, pump source **900** can comprise a solid state laser, such as Nd:YAG or Nd:YLF laser, a semiconductor laser, a laser diode, a cladding pump fiber laser, or any combination of these or other light sources. In this example, pump source **900** comprises a high powered laser **902** coupled to a Raman oscillator or a Raman wavelength shifter, such as Raman wavelength shifters **800**, **820**, **840**, or **860** of FIGS. 8A through 8D.

[0105] FIG. 9B is a block diagram illustrating one example embodiment of a pump source **920** capable of being coupled to a Raman wavelength shifter and/or a Raman oscillator. In this example, pump source **920** includes a pump laser **922** and an intermediate stage **924** capable of shifting the optical signal wavelength generated by pump laser **922** to a longer wavelength. The structure and function of laser **922** may be substantially similar to the structure and function of pump source **900** of FIG. 9A. In this particular example, intermediate stage **924** comprises a first Raman wavelength shifter **924**. In some embodiments, intermediate wavelength shifter **924** may advantageously be implemented using fused silica optical fiber.

[0106] In some embodiments, pump sources **900** and **920** may comprise a cladding-pumped fiber laser, capable of emitting a pump signal wavelength of approximately 1 micron. In those examples, pump sources **900** and **920** can be coupled to a first or auxiliary cascaded Raman oscillator or Raman wavelength shifter. In some cases, the auxiliary Raman oscillator or Raman wavelength shifter may comprise, for example, Raman wavelength shifters **800**, **820**, **840**, or **860** of FIGS. 8A through 8D implementing a fused silica optical fiber. Such an arrangement may be used to shift the 1 micron optical signal to approximately 2 to 2.3 microns. The 2-2.3 micron signal output from the auxiliary Raman wavelength shifter can then be shifted to a mid-IR wavelength by another cascaded Raman oscillator or Raman wavelength shifter that implements in mid-IR fiber.

[0107] FIG. 9C is a block diagram illustrating one example embodiment of a pump source **940** capable of being coupled to a Raman wavelength shifter and/or a Raman oscillator. In this example, pump source **940** includes a pump laser **942** and a multiplexer **944** capable of combining a plurality of pump signals into a pump output signal. In this particular example, pump source **900** comprises a first laser diode **942a** and a second laser diode **942b** each centered at a desired wavelength and capable of generating pump signals **943a** and **943b**. Although this example includes two laser diodes, any number of laser diodes may be used without departing from the scope of the present disclosure. In various embodiments, laser diodes **942a** and **942b** can be centered on substantially the same wavelength, such as 980 nm, 1310 nm, 1390 nm, 14xx nm, or 1510 nm. In this particular embodiment, pump signals **943a** and **943b** are combined by multiplexer **944**. Multiplexer **944** can comprise any device capable of combining pump signals **943**, such as a wavelength division multiplexer. In various embodiments, multiplexer **944** can be capable of polarization and/or wavelength multiplexing pump signals **943a** and **943b** to form a pump output signal.

[0108] In some embodiments, a Raman wavelength shifter, such as those illustrated in FIGS. 8A through 8D, may be used to deliver an optical signal wavelength directly to the patient. In other embodiments, a second mid-IR waveguide structure,

that at least partially transmits in at least a portion of the mid-IR wavelength range, may be coupled to the output of the Raman wavelength shifter to deliver the optical signal wavelength to the patient. Coupling a second mid-IR waveguide structure to the Raman wavelength shifter can advantageously allow the delivery waveguide structure to be disposed after use within the patient. In addition, coupling a second mid-IR waveguide structure can substantially reduce the chance of breaking a fiber associated with a Raman wavelength shifter. Furthermore, it may be desirable to couple a tapered end or lens on the delivery fiber for improved focusing of optical signal on the patient.

[0109] In various embodiments, an optical signal wavelength is capable of being delivered to a medical device inserted into a patient using a waveguide structure having a relatively low coupling loss. In some cases, the waveguide structure maintain the coupling loss to, for example, 5 dB or less, 3 dB or less, or even less than 1 dB.

[0110] Although the present invention has been described with several embodiments, a multitude of changes, substitutions, variations, alterations, and modifications may be suggested to one skilled in the art, and it is intended that the invention encompass all such changes, substitutions, variations, alterations, and modifications as fall within the spirit and scope of the appended claims.

1-20. (canceled)

21. A diagnostic system comprising:

a light source comprising:

a plurality of semiconductor diodes with light beams;
a multiplexer capable of combining the plurality of semiconductor diode light beams and generating at least a multiplexed light beam comprising one or more wavelengths;

one or more waveguide structures configured to receive at least a portion of the one or more wavelengths and to communicate at least the portion of the one or more wavelengths to an output end of the one or more waveguide structures to form an output beam; and

a lens system configured to receive at least a portion of the output beam and to communicate at least the portion of the output beam onto a part of a user's body comprising blood to perform a measurement on a user;

a software application capable of generating data based at least in part on the measurement on the user, wherein the data represents at least in part physiological information associated with the user;

the software application capable of operating on a control system adapted to receive, store and process at least a portion of the physiological information, the control system having a touch-screen, a proximity sensor, and a wireless transceiver to transmit wireless data over a wireless link, the wireless data comprising at least a part of the physiological information, wherein the control system is further capable of receiving voice input signals and manually entered input signals; and

a host comprising:

a digital file for receiving and storing at least a portion of the wireless data;

control logic at the host to process at least the portion of the wireless data to generate a status of the user;

a memory storage device for recording the status; and
an output for communicating at least a portion of the status or associated information over a communica-

tion link to one or more display output devices, wherein the one or more display output devices are located remotely from the host.

22. The diagnostic system of claim **21**, wherein at least the portion of the output beam is adapted for use in a diagnostics to measure a property of the blood, wherein the diagnostics comprise a spectroscopic procedure, wherein the spectroscopic procedure is based at least in part on a comparison of amplitudes at a plurality of associated wavelengths transmitted or reflected from the blood.

23. The diagnostic system of claim **21**, wherein the physiological information is blood pressure, heart rate or blood oxygen level.

24. The diagnostic system of claim **21**, wherein the control system is further coupled to a headset or a heads-up display.

25. The diagnostic system of claim **21**, wherein the control logic includes voice recognition software to process at least a portion of the voice input signals, and wherein the control system further comprises a voice recognition module.

26. The diagnostic system of claim **21**, wherein the control system is further coupled to an audio output device capable of communicating at least a part of the processed portion of the physiological information.

27. A diagnostic system comprising:

a light source comprising:

one or more semiconductor diodes generating an input light beam; and

a lens system configured to receive at least a portion of the input light beam and to communicate at least the portion of the input light beam onto a part of a user's body comprising blood, wherein at least the portion of the input light beam is used in a measurement on a user;

a software application capable of generating data based at least in part on the measurement on the user, wherein the data represents at least in part physiological information associated with the user;

the software application capable of operating on a control system adapted to receive, store and process at least a portion of the physiological information, the control system having a touch-screen, circuitry for obtaining position information from a location sensor, and a wireless transceiver to transmit wireless data over a wireless link, the wireless data comprising at least a part of the physiological information, wherein the control system is further capable of receiving voice input signals and manually entered input signals; and

a host comprising:

a digital file for receiving and storing at least a portion of the wireless data;

control logic at the host to process at least the portion of the wireless data to generate a status of the user;

a memory storage device for recording the status; and
an output for communicating at least a portion of the status or associated information over a communication link to one or more display output devices, wherein the one or more display output devices are located remotely from the host.

28. The diagnostic system of claim **27**, wherein the light source comprises a plurality of semiconductor diodes that are further coupled to a multiplexer capable of combining the plurality of semiconductor diodes and generating the input light beam comprising one or more wavelengths.

29. The diagnostic system of claim **28**, wherein the multiplexer is further coupled to one or more waveguide structures configured to receive at least a portion of the one or more wavelengths and to communicate at least the portion of the input light beam.

30. The diagnostic system of claim **27**, wherein at least the portion of the input light beam is adapted for use in a diagnostics to measure a property of the blood, wherein the diagnostics comprise a spectroscopic procedure, wherein the spectroscopic procedure is based at least in part on a comparison of amplitudes at a plurality of associated wavelengths transmitted or reflected from the blood.

31. The diagnostic system of claim **27**, wherein the control system is further coupled to a headset or a heads-up display.

32. The diagnostic system of claim **27**, wherein the control logic includes voice recognition software to process at least a portion of the voice input signals, and wherein the control system further comprises a voice recognition module.

33. The diagnostic system of claim **27**, wherein the physiological information is blood pressure, heart rate or blood oxygen level.

34. The diagnostic system of claim **27**, wherein the control system is further coupled to a proximity sensor.

35. The diagnostic system of claim **27**, wherein the control system is further coupled to an audio output device capable of communicating at least a part of the processed portion of the physiological information.

36. A diagnostic system comprising:

a light source comprising:

one or more semiconductor diodes generating an input light beam; and

a lens system configured to receive at least a portion of the input light beam and to communicate at least the portion of the input light beam onto a part of a user's body comprising blood, wherein at least the portion of the input light beam is used in a measurement on a user, wherein the measurement comprises a spectroscopic procedure to measure a property of the blood, and wherein the spectroscopic procedure is based at least in part on a comparison of amplitudes at a plurality of associated wavelengths transmitted or reflected from the blood;

a software application capable of generating data based at least in part on the measurement on the user, wherein the data represents at least in part physiological information associated with the user;

the software application capable of operating on a control system adapted to receive, store and process at least a portion of the physiological information, the control system having a touch-screen, circuitry for obtaining position information from a location sensor, and a wireless transceiver to transmit wireless data over a wireless link, the wireless data comprising at least a part of the physiological information, wherein the control system is further capable of receiving voice input signals and manually entered input signals, and wherein the control system is further coupled to an audio output device; and a host comprising:

a digital file for receiving and storing at least a portion of the wireless data;

control logic at the host to process at least the portion of the wireless data to generate a status of the user, wherein the control logic includes a voice recognition software to process at least a portion of the voice input signals;

a memory storage device for recording the status; and an output for communicating at least a portion of the status or associated information over a communication link to one or more display output devices, wherein the one or more display output devices are located remotely from the host.

37. The diagnostic system of claim **36**, wherein the control system is further coupled to a headset or a heads-up display.

38. The diagnostic system of claim **37**, wherein gesture signals are capable of being generated in response to a head motion.

39. The diagnostic system of claim **36**, wherein the control system is further coupled to a proximity sensor.

40. The diagnostic system of claim **36**, wherein the host is adapted to permit access of the status or associated information stored on the host from two or more different locations remote from the host.

* * * * *

| | | | |
|----------------|--|---------|------------|
| 专利名称(译) | 用于医疗设备的语音控制的系统和方法 | | |
| 公开(公告)号 | US20140371555A1 | 公开(公告)日 | 2014-12-18 |
| 申请号 | US14/476082 | 申请日 | 2014-09-03 |
| [标]申请(专利权)人(译) | OMNI MEDSCI | | |
| 申请(专利权)人(译) | OMNI MEDSCI INC. | | |
| 当前申请(专利权)人(译) | OMNI MEDSCI INC. | | |
| [标]发明人 | ISLAM MOHAMMED N | | |
| 发明人 | ISLAM, MOHAMMED N. | | |
| IPC分类号 | A61B5/00 A61B5/024 A61B5/021 A61B5/1455 | | |
| CPC分类号 | A61B5/0075 A61B5/14551 A61B5/024 A61B5/749 A61B5/0022 A61B5/742 A61B5/021 A61B1/00039 A61B5/0013 A61B5/0084 A61B5/02042 A61B5/06 A61B5/1455 A61B5/7264 A61B5/7435 A61B5/7445 A61B34/70 A61B2505/05 G06F19/00 H01S3/302 | | |
| 优先权 | 60/408025 2002-09-03 US | | |
| 其他公开文献 | US9055868 | | |
| 外部链接 | Espacenet USPTO | | |

摘要(译)

诊断系统包括多个半导体二极管，多路复用器和一个或多个波导结构，以形成输出光束。透镜系统将一些输出光束传送到包括血液的用户身体的一部分上以执行测量。软件应用程序能够至少部分地基于测量生成数据，并且其在可以具有触摸屏，接近传感器和无线收发器的控制系统上操作，以通过无线链路发送无线数据。主机包括数字文件，主机处的控制逻辑，用于处理至少部分无线数据以生成用户的状态，用于记录状态的存储器存储设备，以及用于通信至少一部分通过到一个或多个远程显示输出设备的通信链路的状态或相关信息。

