



(19) **United States**  
(12) **Patent Application Publication**  
**Callahan et al.**

(10) **Pub. No.: US 2014/0221856 A1**  
(43) **Pub. Date: Aug. 7, 2014**

(54) **ECG LEADWIRE SYSTEM WITH NOISE SUPPRESSION AND RELATED METHODS**

(52) **U.S. Cl.**  
CPC ..... *A61B 5/04286* (2013.01); *A61B 5/04017* (2013.01); *A61B 5/7217* (2013.01)  
USPC ..... **600/509**

(71) Applicant: **Covidien LP**, Mansfield, MA (US)

(72) Inventors: **Mark J. Callahan**, Medway, MA (US);  
**Glenn Gilbert**, Plymouth, MA (US);  
**Scott R. Coggins**, Littleton, MA (US);  
**Linda D'Elia**, Westfield, MA (US)

(57) **ABSTRACT**

(73) Assignee: **Covidien LP**, Mansfield, MA (US)

(21) Appl. No.: **14/135,239**

(22) Filed: **Dec. 19, 2013**

A noise-suppressing electrocardiograph (ECG) adapter having a first end, a second end, and a noise-suppression element is presented, together with an ECG noise-suppressing system and related methods. In an embodiment, the noise-suppressing ECG adapter includes a housing having at least one first connector disposed at a first end of the housing adapted to electrically couple with an ECG lead set, and at least one second connector adapted for coupling to an input of an ECG device. The adapter includes a noise suppression element. The noise suppression element includes a ferromagnetic element having an opening defined therein. In an embodiment the noise suppression element is internal to the adapter. In another embodiment, the noise suppression element is tethered externally to the adapter and configured to clamp around at least a portion of an ECG leadwire.

**Related U.S. Application Data**

(62) Division of application No. 13/249,450, filed on Sep. 30, 2011, now Pat. No. 8,634,901.

**Publication Classification**

(51) **Int. Cl.**  
*A61B 5/0428* (2006.01)  
*A61B 5/00* (2006.01)  
*A61B 5/04* (2006.01)

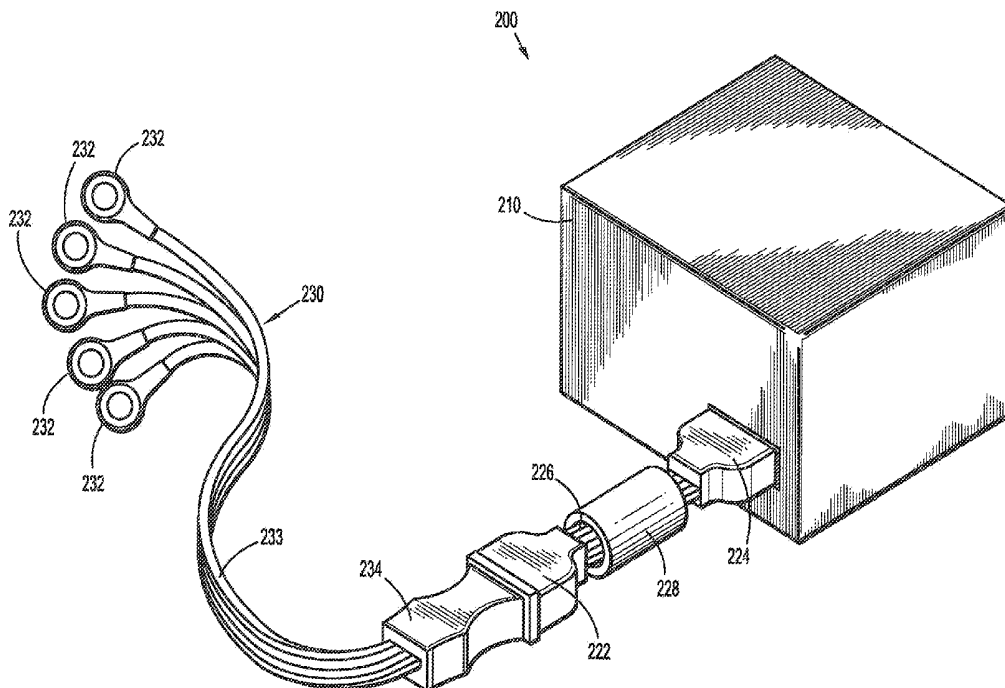

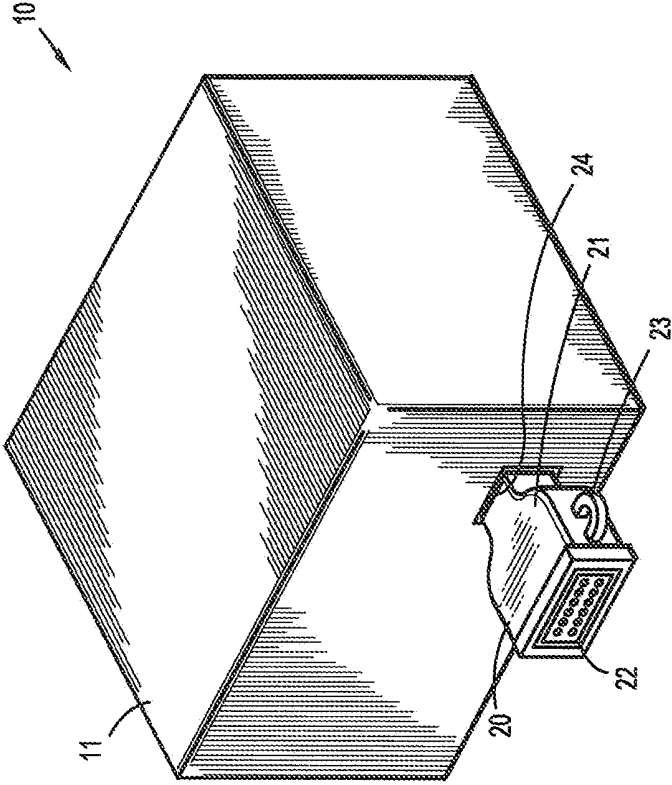

FIG. 1

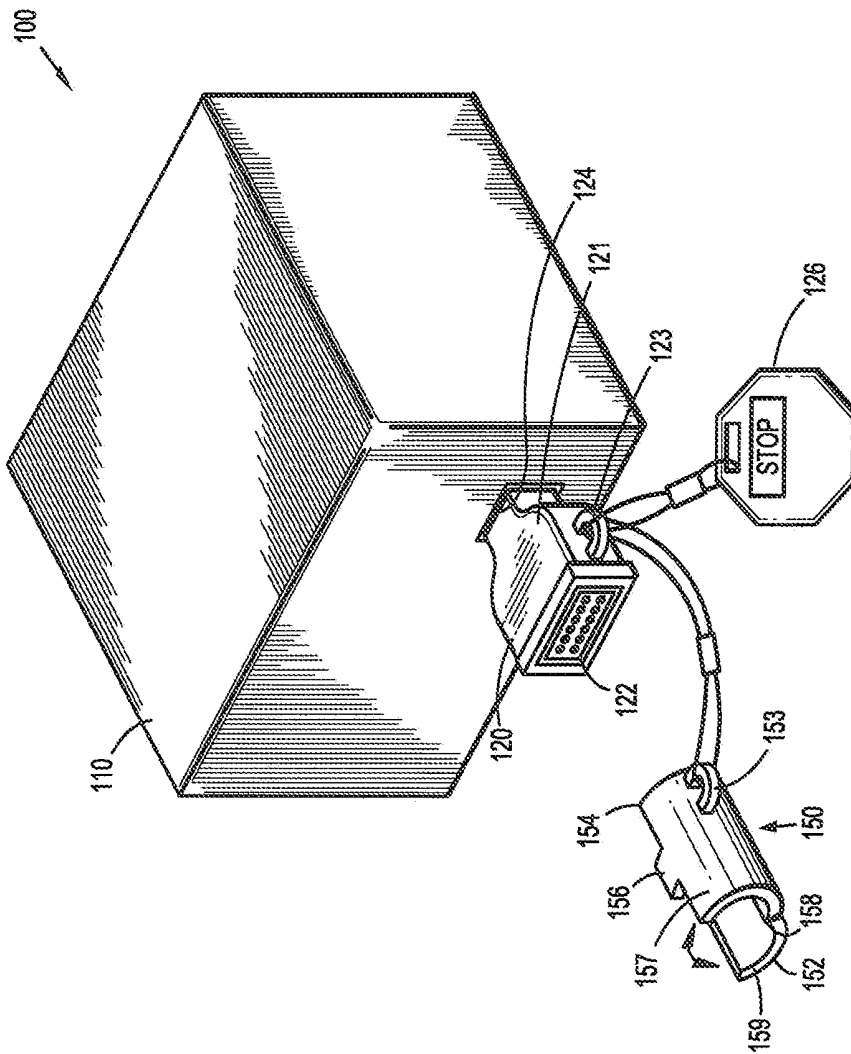

FIG. 2A

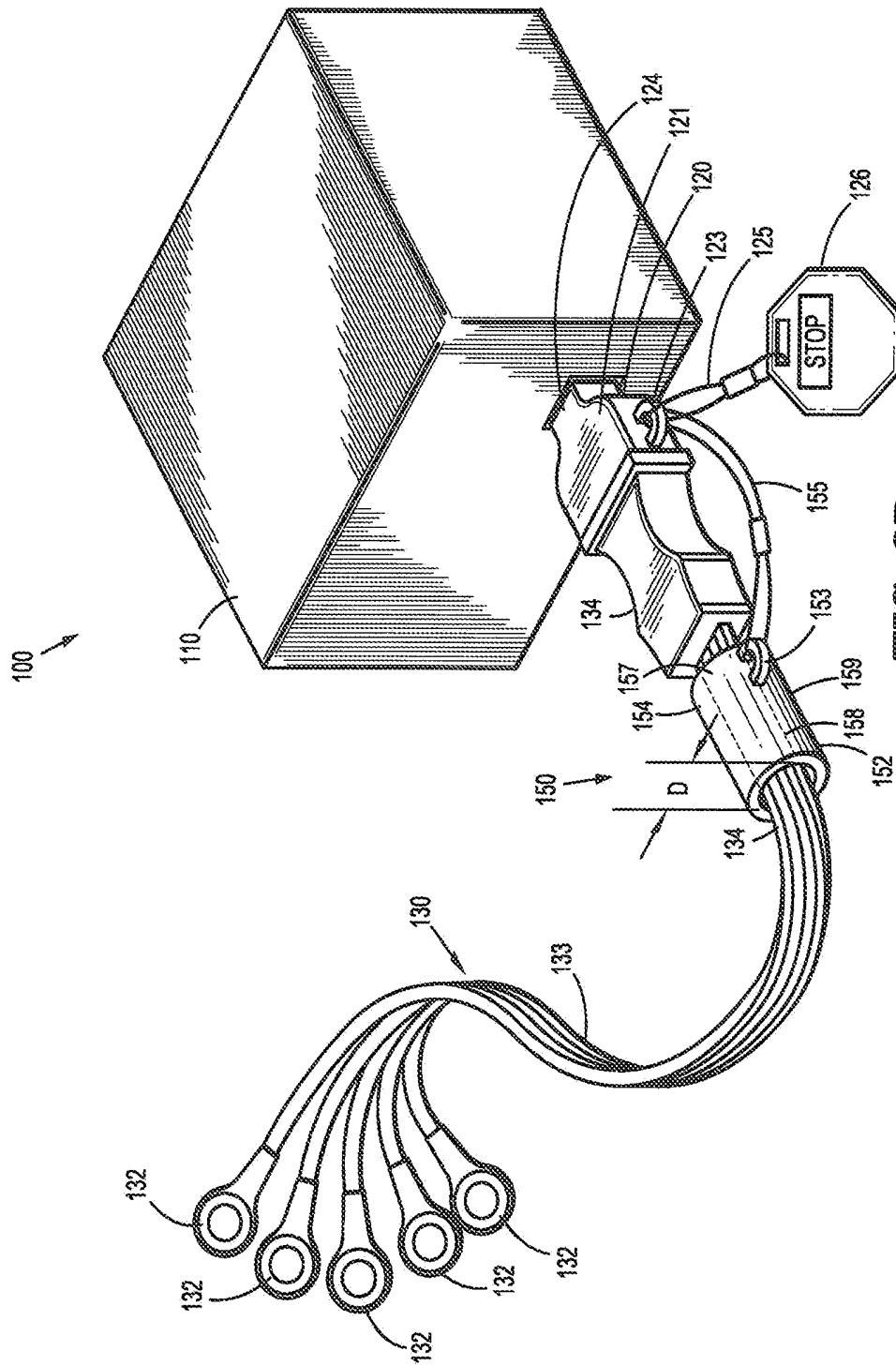

FIG. 2B

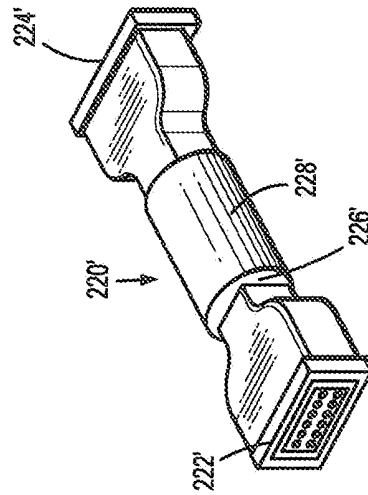

FIG. 3B

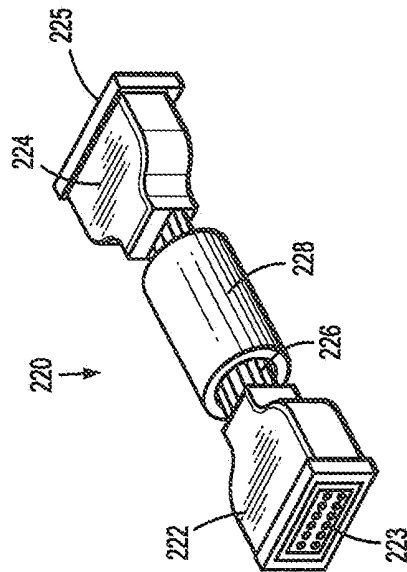

FIG. 3A

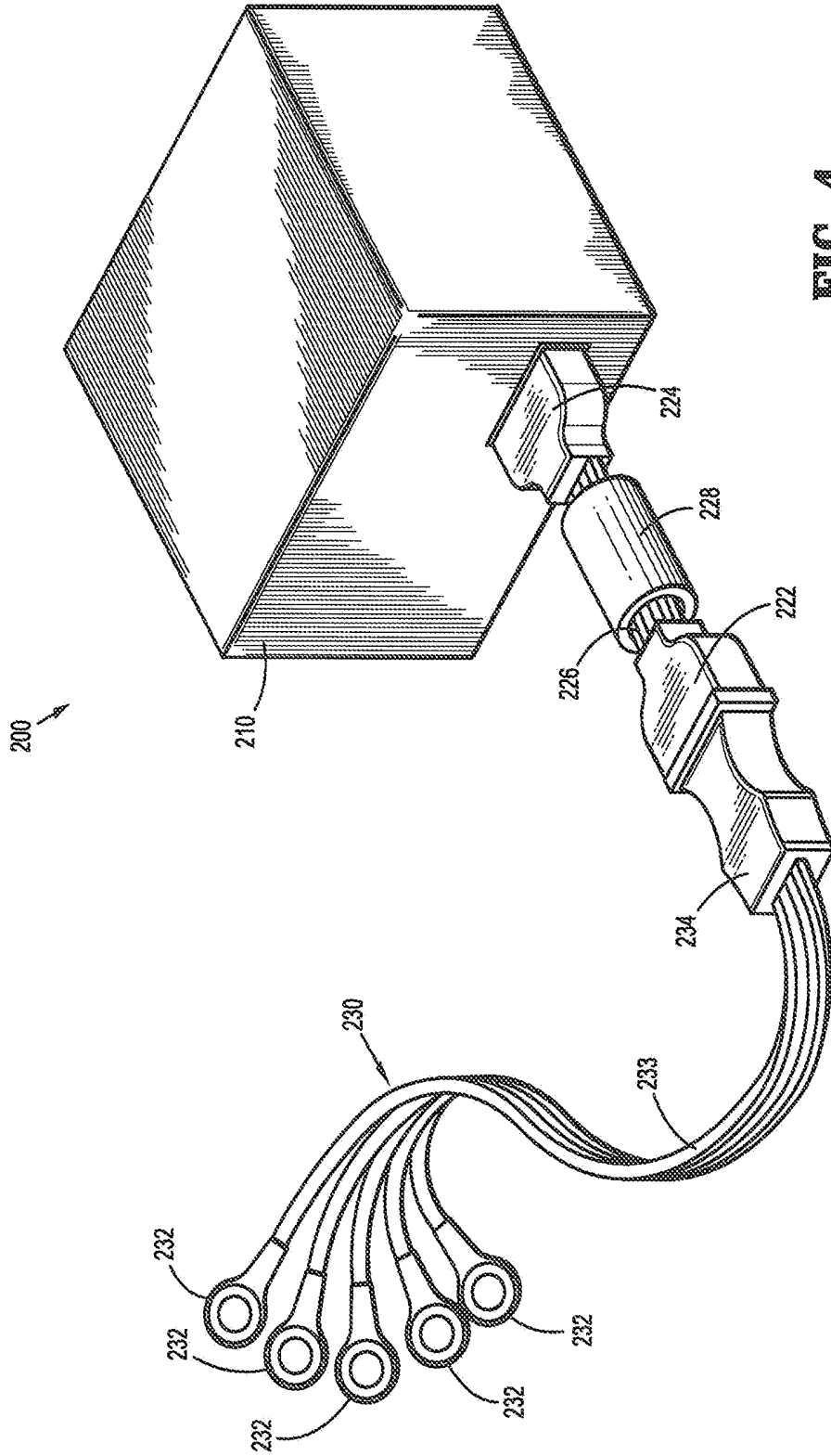
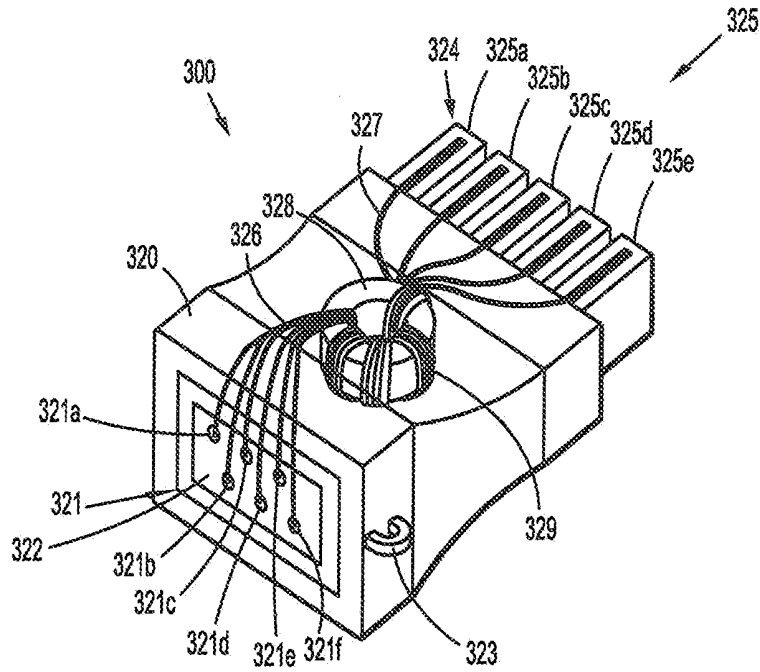
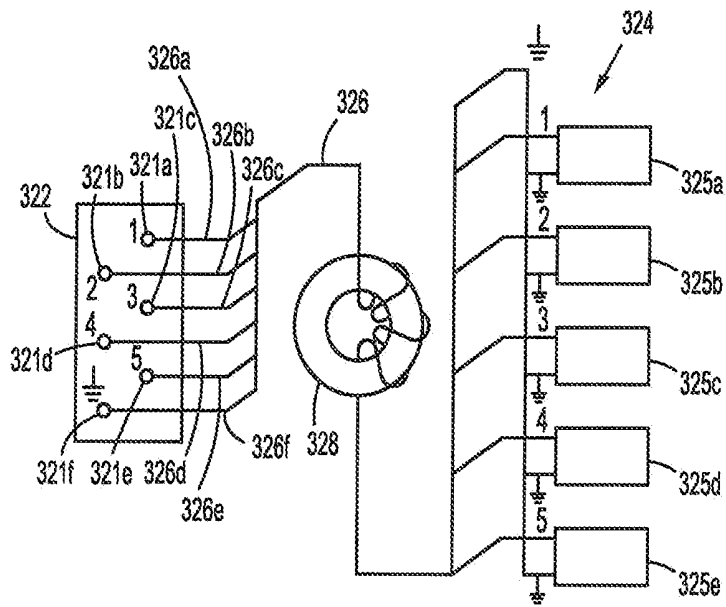

FIG. 4



**FIG. 5A**



**FIG. 5B**

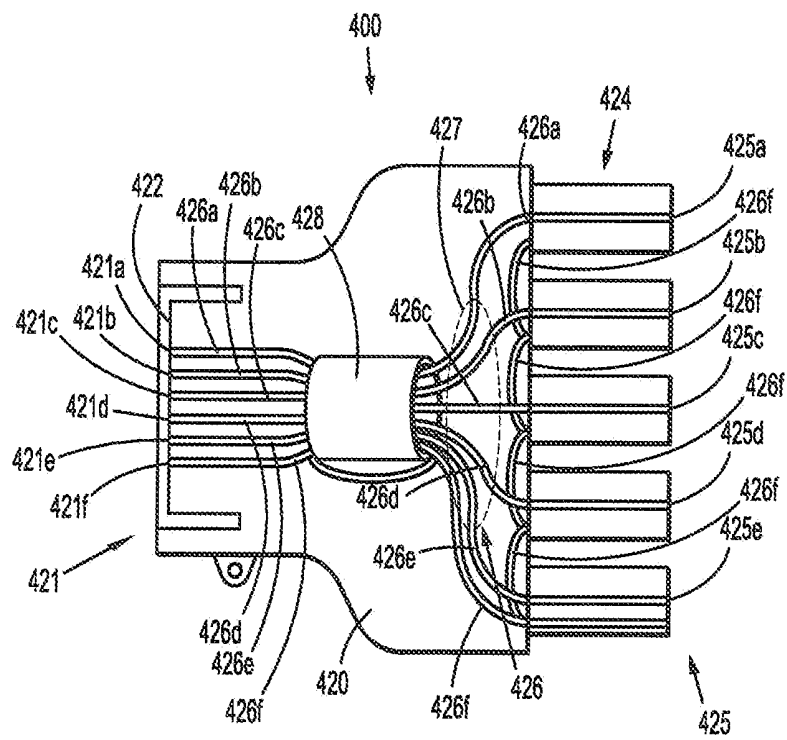

FIG. 6

## ECG LEADWIRE SYSTEM WITH NOISE SUPPRESSION AND RELATED METHODS

### RELATED APPLICATIONS

[0001] This is a DIVISIONAL application under 35 U.S.C. §121 of U.S. patent application Ser. No. 13/249,450 (filed Sep. 20, 2011), which is incorporated here by reference in its entirety.

### TECHNICAL FIELD

[0002] The present disclosure relates to medical equipment. In particular, the present disclosure relates to an electrocardiograph (ECG) leadwire system having improved noise reduction characteristics that includes an ECG lead set, an adapter system, an extension cable, a noise reduction element, and methods for coupling the ECG lead sets with the adapter.

### BACKGROUND

[0003] ECG lead systems are used to obtain biopotential signals containing information indicative of the electrical activity associated with the heart and pulmonary system. To obtain biopotential signals, ECG electrodes are applied to the skin of a patient in various locations and coupled to an ECG device, e.g., an "ECG monitor" or "ECG telemetry." Placement of the electrodes is dependent on the information sought by the clinician.

[0004] The placement of the ECG electrodes on the patient has been established by medical protocols. The most common protocols require the placement of the electrodes in a three-lead, a five-lead, or a twelve-lead configuration. A three-lead configuration requires the placement of three electrodes; one electrode adjacent each clavicle bone (RA, LA) on the upper chest and a third electrode adjacent the patient's lower left abdomen (LL). A five-lead configuration requires the placement of the three electrodes in the three-lead configuration with the addition of a fourth electrode adjacent the sternum (Va) and a fifth electrode on the patient's lower right abdomen (RL). A twelve-lead configuration requires the placement of ten electrodes on the patient's body. Four electrodes, which represent the patient's limbs, include the left arm electrode (LA lead), the right arm electrode (RA lead), the left leg electrode (LL lead), and the right leg electrode (RL lead). Six chest electrodes (V1-V6 leads) are placed on the patient's chest at various locations near the heart. Three standard limb leads are constructed from measurements between the right arm and left arm (Lead I), the right arm and the left leg (Lead II) and the left arm to left leg (Lead III). Other conventional lead configurations include a 14 leads system that incorporated additional leads located on a back surface.

[0005] An ECG lead set typically includes an array of three, five, or twelve leads as determined by the intended clinical protocol. Each individual lead wire includes, at a patient end thereof (e.g., distal end), an ECG lead wire connector configured to operably couple the lead wire to an electrode pad affixed to the body of a patient. At the opposite (e.g., proximal) end, the individual lead wires are gathered into a common coupler that is configured to operably couple the array of lead wires to an ECG device. Leads sets are typically provided with a generous length of lead wire sufficient to reach from the patient to the ECG device. In some instances, however, the lead wire may fall short, in which case a lead wire extension cable having appropriate distal and proximal cou-

plers may be employed. In some instances, the lead wire coupler of an ECG lead set and/or ECG lead extension may be incompatible with an available ECG device, in which case an ECG adapter may be employed that facilitates operable coupling of the otherwise-incompatible physical and/or electrical characteristics of the disparate couplers.

[0006] Radio frequency interference (RFI), sometime referred to as electromagnetic interference (EMI), is a disturbance that affects an electrical circuit due to either electromagnetic induction or electromagnetic radiation emitted from an external source. The disturbance may interrupt, obstruct, or otherwise degrade or limit the effective performance of a circuit. Biopotential signals are generally very low-level signals, and a typical ECG device has a very high input impedance. As a result, biopotential signals may be susceptible to RFI, particularly from devices that may be in use concurrently in a clinical environment, e.g., an electro-surgical instrument, or a microwave ablation unit. RFI may be exacerbated when an ECG lead wire extension cable is used.

### SUMMARY

[0007] The present disclosure is directed to a noise-suppressing ECG adapter. In some embodiments the disclosed adapter includes a housing having a first end and a second end, and at least one first connector disposed at the first end of the housing. The at least one first connector is adapted for operably coupling to a proximal end of an ECG lead set. The disclosed adapter includes at least one second connector disposed at the second end of the housing that is adapted for coupling to an input of an ECG device. A noise suppression element is disposed within the housing, and includes one of a ferromagnetic element and an electromagnet having an opening defined therein. A least one conductor operably couples the first connector and the second connector, and passes through the opening defined in the ferromagnetic element. The noise suppression element of the adapter may include a low pass filter, a high pass filter, a notch filter, or a nyquist filter. In some embodiments, a connector includes a six-pin configuration. In some embodiments, the six-pin configuration comprises five signal pins and one ground pin. In some embodiments, a connector includes one signal pin and one ground pin.

[0008] In some embodiments, the ferromagnetic element includes a shape selected from the group consisting of a toroid and an open cylinder. The ferromagnetic element may be formed from material selected from the group consisting of ferrite and laminated iron. At least one conductor may pass through the opening of the ferromagnetic element in a plurality of windings.

[0009] Also disclosed is a noise-suppressing ECG system. In some embodiments, the disclosed system includes a noise-suppressing ECG adapter, comprising a housing having a first end and a second end, at least one first connector disposed at the first end of the housing, the at least one first connector adapted for operably coupling to proximal end of ECG lead set. The adapter includes at least one second connector disposed at the second end of the housing adapted for coupling to an input of an ECG device. The adapter includes a noise suppression element disposed within the housing, the noise suppression element including a ferromagnetic element having an opening defined therein, and at least one conductor operably coupling the first connector and the second connector and passing through the opening of the ferromagnetic element. The system includes an ECG device adapted to

operably couple to the at least one second connector of the noise-suppressing ECG adapter.

**[0010]** In some embodiments, the disclosed noise-suppressing ECG system includes an ECG lead set including a plurality of lead wires at a distal end thereof that are configured to operably couple to a plurality of ECG pads, and at least one ECG connector disposed at a proximal end of ECG leadwire set. The noise-suppressing ECG system, in some embodiments, includes a noise suppression element that includes a low pass filter, a high pass filter, a notch filter and a nyquist filter.

**[0011]** In some embodiments, the disclosed noise-suppressing ECG system includes an ECG adapter having a connector having a six-pin configuration. The six-pin configuration may include five signal pins and one ground pin. Other embodiments may include a connector that contains 12 pins with 2 separate grounds pins. Still other examples may utilize shielded leadwires that use two pins for each contact, one for signal and one for shield.

**[0012]** In some embodiments, the disclosed noise-suppressing ECG system includes an ECG adapter having a connector that includes one signal pin and one ground pin.

**[0013]** In some embodiments, the disclosed noise-suppressing ECG system includes an ECG adapter having a ferromagnetic element that includes a shape selected from the group consisting of a toroid and an open cylinder.

**[0014]** In some embodiments, the disclosed noise-suppressing ECG system includes an ECG adapter wherein the at least one conductor passes through the opening of the ferromagnetic element in a plurality of windings. In another embodiment, electromagnets could be actuated as part of the interface to the ECG monitor so that the magnetic field used to attenuate the electromagnetic interference would only be present when the ECG system was in use.

**[0015]** In some embodiments, the disclosed noise-suppressing ECG system includes an ECG adapter wherein the ferromagnetic element is formed from material selected from the group consisting of ferrite and laminated iron.

**[0016]** Also disclosed is a method of suppressing noise in an ECG system. In some embodiments, the disclosed method includes providing an ECG adapter including an ECG leadwire connector, an ECG device connector, and a noise suppression element. The method includes operably coupling the ECG device connector to an ECG device, and operably coupling an ECG leadwire set to the ECG leadwire connector.

**[0017]** In some embodiments, the disclosed method of suppressing noise in an ECG system includes positioning the noise suppression element around at least a portion of the ECG leadwire set. In some embodiments, the disclosed method of suppressing noise in an ECG system includes a positioning step that further includes closing two semicylindrical halves of a ferromagnetic collar around at least a portion of the ECG leadwire set.

**[0018]** Other advantages, novel features, and objects of the present disclosure will become apparent from the following detailed description of the present disclosure when considered in conjunction with the accompanying drawings, which are schematic and are not intended to be drawn to scale. For purposes of clarity, not every component is labeled in every figure, nor is every component of each embodiment of the present disclosure shown where illustration is not necessary to allow those of ordinary skill in the art to understand the present disclosure.

## BRIEF DESCRIPTION OF THE DRAWINGS

**[0019]** Various embodiments of the subject instrument are described herein with reference to the drawings wherein:

**[0020]** FIG. 1 is a schematic view of an embodiment of a noise suppressing adapter in accordance with the present disclosure;

**[0021]** FIG. 2A is a schematic view of an embodiment of a noise suppressing collar annexed to an adapter;

**[0022]** FIG. 2B is a schematic view of an embodiment of the noise suppressing collar of FIG. 2A operatively coupled to a set of leadwires in accordance with the present disclosure;

**[0023]** FIG. 3A is a schematic view of another embodiment of a noise suppressing collar in accordance with the present disclosure;

**[0024]** FIG. 3B is a schematic view of a variation of the FIG. 3A embodiment of a noise suppressing collar in accordance with the present disclosure;

**[0025]** FIG. 4 is a schematic view of the FIG. 3A embodiment of a noise suppressing collar operatively coupled to a set of leadwires in accordance with the present disclosure;

**[0026]** FIG. 5A is a view of still another embodiment of a noise suppressing adapter in accordance with the present disclosure;

**[0027]** FIG. 5B is a circuit diagram of the FIG. 5A embodiment; and

**[0028]** FIG. 6 is a view of yet another embodiment of a noise suppressing adapter in accordance with the present disclosure.

## DETAILED DESCRIPTION

**[0029]** Particular embodiments of the present disclosure are described hereinbelow with reference to the accompanying drawings; however, it is to be understood that the disclosed embodiments are merely examples of the disclosure, which may be embodied in various forms. The terminology used herein is for the purpose of describing particular embodiments only, and is not intended to be limiting. Well-known and/or repetitive functions and constructions are not described in detail to avoid obscuring the present disclosure in unnecessary or redundant detail. Therefore, specific structural and functional details disclosed herein are not to be interpreted as limiting, but merely as a basis for the claims and as a representative basis for teaching one skilled in the art to variously employ the present disclosure in virtually any appropriately detailed structure. As used herein, and as is traditional, the term “distal” refers to the portion which is furthest from the user/clinician and the term “proximal” refers to the portion that is closest to the user/clinician. In addition, terms such as “above,” “below,” “forward,” “rearward,” etc. refer to the orientation of the figures or the direction of components and are simply used for convenience of description. It is to be understood that embodiments in accordance with the present disclosure may be practiced in any orientation without limitation. In this description, as well as in the drawings, like-referenced numbers represent elements which may perform the same, similar, or equivalent functions. References to connector gender presented herein are for illustrative purposes only, and embodiments are envisioned wherein the various components described can be any of mate, female, hermaphroditic, or sexless gender. Likewise, references to connector types are illustrative in nature, and other connector types, shapes and configurations are contemplated within the scope of the present disclosure.

**[0030]** With reference to FIG. 1, an ECG monitoring system **10** having a noise suppressing ECG adapter **20** is shown. According to one embodiment of the present disclosure, the system **10** enables an end user to use a single ECG leadwire set **30** in association with one or more disparate ECG devices **11**, e.g., an ECG monitoring device and/or an ECG telemetry device, as desired. ECG adapter **20** includes an adapter housing **21** having a first end **22** and a second end **24**. In the embodiment shown in FIG. 1, first end **22** includes a pin configuration having a six-pin arrangement that is adapted to operatively couple with a corresponding, mating six-pin connector **34** disposed at a proximal end of ECG leadwire set **130** having one or more ECG electrode connectors **32** adapted to operatively couple to an ECG electrode pad affixed to a patient. ECG adapter second end **24** includes a pin configuration adapted to mate with a corresponding connector provided by ECG device **11**.

**[0031]** Noise suppression element may be formed from any material having suitable electromagnetic, coercivity, and permeability properties, including without limitation, ferrite, laminated iron, and the like. In one embodiment, the noise suppression element is one of a ferromagnetic element and an electromagnet. An electromagnet noise suppression element may draw power from a monitor to which it is connected. An electromagnetic noise suppression element may be actuated as part of an interface to an ECG monitor so that the magnetic field used to attenuate the electromagnetic interference would only be present when the ECG system was in use.

**[0032]** The noise suppression element may include a filter such as a low pass filter, a high pass filter, a notch filter, and a nyquist filter. The passive low pass filter exhibits high impedance at high frequencies typically associated with RFI, which, in turn, attenuates or suppresses RFI within the one or more leadwires **134** and/or high-impedance input circuit of the ECG device.

**[0033]** The pin configurations of first end **22** and/or second end **24** may vary depending on the desired application, the intended ECG device(s) **110** to be used, and the specific lead set or lead sets to be used. For example, and without limitation, pin configuration of first end **22** may include only a single pin used in an unshielded configuration of a single electrode lead set. In another non-limiting example, the pin configuration of second end **24** of ECG connector **20** may include a five-pin male socket connector. In this example, each plug includes a pair of contacts, wherein one plug corresponds to one ECG lead and the corresponding plug corresponds to a ground or shield lead, such as specified by ANSI/AAMI EC53 for shielded leadwire to trunk cable interconnections. The second end **24** of ECG connector **20** may be referred to as monitor plugs. The second end or monitor plugs **24** are configured for coupling to the lead set input connector of ECG device **11**.

**[0034]** ECG adapter **20** includes a tether boss **23** that enables one or more tethers, e.g., an additional noise suppressor tether (not shown) and/or a placard tether (not shown), to be affixed thereto. As shown, tether boss **23** includes a u-shaped protuberance having an opening defined therein that extends from an exterior surface of ECG connector **20**, however, other tether boss arrangement are contemplated, such as, and without limitation, to a recess with a transverse pin arrangement. A placard annexed to connector **20** may include an inscription conveying operating instructions, e.g., "STOP-Do Not Discard-Reusable" and the like.

**[0035]** Turning to FIGS. 2A and 2B, ECG adapter **120** includes a noise suppressor collar **150** that is annexed thereto by noise suppressor tether **155**. In one embodiment, adapter **120** does not comprise a noise suppression component within its housing. In one embodiment, the noise suppression element is one of a ferromagnetic element and an electromagnet. An electromagnet noise suppression element may draw power from a monitor to which it is connected. An electromagnetic noise suppression element may be actuated as part of an interface to an ECG monitor so that the magnetic field used to attenuate the electromagnetic interference would only be present when the ECG system was in use.

**[0036]** In another embodiment, adapter **120** may be a noise suppression adapter comprising a noise suppression component within its housing. The noise suppression element in the adapter may, but need not, be of a similar type to that used in the noise suppression collar. For example, the noise suppression element in the adapter may be one of a ferromagnetic element and an electromagnet, while the noise suppression collar may be the other of the ferromagnetic element and the electromagnet. Alternatively, the noise suppression adapter and the noise suppression collar may comprise both a ferromagnetic element or both comprise an electromagnet.

**[0037]** In one embodiment, the noise suppression adapter may comprise a first filter and the noise suppression collar may comprise a second filter, which may, but need not, be the same type of filter as the first filter. For example, the noise suppression adapter may comprise one of a low pass filter, a high pass filter, a notch filter, and a nyquist filter, while the noise suppression collar may comprise a different one of a low pass filter, a high pass filter, a notch filter, and a nyquist filter.

**[0038]** Noise suppressor collar may **150** include a tether boss **153** that is adapted to enable noise suppressor tether **155** to be affixed to collar **150**. Noise suppressor collar **150** is selectively configurable between an open configuration as illustrated in FIG. 2A, and a closed configuration as illustrated in FIG. 2B. When configured in a closed configuration, noise suppressor collar **150** has a generally open cylindrical or tubular (e.g., pipe-like or elongate toroid) shape having an inner diameter "D" that is dimensioned to enable one or more ECG leadwires **134** to pass therethrough. In this embodiment, it is believed that noise suppressor collar **150** forms a common mode choke that suppresses RFI induced by stray electromagnetic fields propagating upon the one or more ECG leadwires **134**.

**[0039]** Noise suppressor collar **150** may be formed from any material having suitable electromagnetic, coercivity, and permeability properties, including without limitation, ferrite, laminated iron, and the like. The noise suppressor collar may include a filter, such as, a low pass filter, a high pass filter, a notch filter, and a nyquist filter. It is believed that this composition, e.g., ferrite, in cooperation with the open cylindrical or tubular shape of noise suppressor collar **150**, forms a passive low-pass filter. The passive low pass filter exhibits high impedance at high frequencies typically associated with RFI, which, in turn, attenuates or suppresses RFI within the one or more leadwires **134** and/or high-impedance input circuit of the ECG device.

**[0040]** In an exemplary embodiment, noise suppressor collar **150** is formed from two generally semi-cylindrical halves consisting of a collar bottom portion **152** and a collar top portion **154** that are joined along a common edge by a hinge **158**. In various embodiments, hinge **158** may include a living

hinge, a piano hinge, or any suitable hinge arrangement. Collar top portion 154 includes a clasp 156 that is configured to engage a corresponding clasp saddle (not explicitly shown) provided by collar bottom portion 152 to join collar bottom portion 152 and collar top portion 154 in the closed configuration shown in FIG. 2. Noise suppressor collar 150 may additionally or optionally include a jacket 157, 159 covering at least a part of a surface of collar bottom portion 152 and a collar top portion 154. Jacket 157, 159 may be formed from any suitable material, such as a polymeric material including without limitation high density polyethylene, polyurethane, and acrylonitrile butadiene styrene. In an embodiment, jacket 157, 159, and hinge 158 may be integrally formed, e.g., from polypropylene. In this embodiment hinge 158 may be in the form of a living hinge.

[0041] During use, a clinician may couple connector 134 of ECG leadwire set 130 with first end 122 of ECG adapter 120. A clinician may separate the two portions 152, 154 of noise suppressor collar 150, e.g., move collar bottom portion 152 and collar top portion 154 to the open configuration as illustrated in FIG. 1. One or more leadwires 134 are positioned between the inner portions of collar bottom portion 152 and collar top portion 154, and the collar bottom portion 152 and collar top portion 154 are moved to the closed configuration as illustrated in FIG. 2. The second end 124 of ECG adapter 120 is mated to an ECG device 110. One or more ECG pads are affixed to a patient, and the one or more ECG electrode connectors 132 are affixed to the one or more ECG pads in accordance with the appropriate protocol (e.g., a three-lead, a five-lead, or a twelve-lead configuration). The ECG device may be activated to commence ECG monitoring, ECG telemetry, and the like.

[0042] Turning to FIGS. 3A and 4, another embodiment of an ECG adapter 220 in accordance with the present disclosure includes a first end 222 that is operatively coupled to a second end 224 by one or more ECG conductors 226. First end 222 of ECG adapter 220 includes a first connector 223 that is adapted to operably couple with a corresponding, mating six-pin connector 234 disposed at a proximal end of ECG leadwire set 230 having one or more ECG electrode connectors 232 adapted to operably couple to an ECG electrode pad affixed to a patient. ECG adapter 220 second end 224 includes a second connector 225 adapted to mate with a corresponding connector provided by ECG device 210.

[0043] ECG adapter 220 includes a noise suppressor collar 228 having a generally open cylindrical or tubular shape (e.g., pipe-like or elongate toroid) that is disposed about at least a portion of the one or more ECG conductors 226. Noise suppressor collar 228 includes an inner diameter that is dimensioned to enable one or more ECG leadwires 226 to pass therethrough. Noise suppressor collar 228 may be formed from any material having suitable electromagnetic, coercivity, and permeability properties as previously described herein, such as, for example, ferrite, laminated iron, and the like. In embodiments, noise suppressor collar 228 may be fixed to the one or more ECG leadwires 226 by any suitable manner of attachment, including without limitation, by an adhesive, by encapsulation, by encasing in heat shrink tubing, and the like. In some embodiments, such as that illustrated in FIG. 3B, an ECG adapter 220' includes a noise suppressor collar 228' that is integrally formed with ECG leadwires 226', a first end 222', and/or a second end 224', wherein ECG adapter 220' is encapsulated in a heat shrink tubing.

[0044] During use, as seen in FIG. 4, a clinician may couple connector 234 of ECG leadwire set 230 to first end 222 of ECG adapter 220, and second end 224 of ECG adapter 220 is mated to an ECG device 210. One or more ECG pads are affixed to a patient, and the one or more ECG electrode connectors 232 are affixed to the one or more ECG pads in accordance with the appropriate protocol (e.g., a three-lead, a five-lead, or a twelve-lead configuration). The ECG device may be activated to commence ECG monitoring, ECG telemetry, and the like.

[0045] Turning now to FIGS. 5A and 5B, still another embodiment of an ECG noise suppression adapter 300 is presented in accordance with the present disclosure. ECG noise suppression adapter 300 includes a housing 320 having a first end 322 and a second end 324. First end 322 includes one or more input terminals 321a-f that are adapted to operably couple with one or more corresponding, mating pins disposed at a proximal end of ECG leadwire set (not explicitly shown) to receive ECG signals therefrom. Second end 324 of housing 320 of ECG noise suppression adapter 300 includes one or more second connectors 325a-e adapted to mate with one or more corresponding connectors provided by an ECG device. In the present embodiment, the one or more second connectors 325a-e includes a pair of contacts, wherein one plug corresponds to one ECG lead and the corresponding plug corresponds to a ground or shield lead, such as specified by ANSI/AAMI EC53 for shielded leadwire to trunk cable interconnections, as described above.

[0046] ECG noise suppression adapter 300 includes a toroidal inductor core 328. Toroidal inductor core 328 may be formed from any material having suitable electromagnetic, coercivity, and permeability properties as previously described herein, such as, without limitation, ferrite and/or laminated iron. One or more ECG conductors 326 are coupled, at a distal end thereof, to one or more input terminals 321a-f. In the present example, six ECG conductors 326 are shown which correspond to input terminals 321a-e (e.g., ECG signals 1 through 5, respectively) and to input terminal 321f that is coupled to a ground (e.g., shield) conductor. The conductors 326 pass around the toroidal inductor core 328 in a plurality of windings to form a low pass choke, or filter, that exhibits high impedance at high frequencies typically associated with RFI as previously described. Conductors 326 may be wound around toroidal inductor core 328 at least one turn, and in some embodiments, may be wound at least five turns, at least ten turns, and/or at least twenty-five turns. In some embodiments, conductors 326 may be grouped and wound collectively, e.g., as a unified cable bundle wound together around toroidal inductor core 328.

[0047] In some embodiments, conductors 326 may be individually wound around toroidal inductor core 328. At a proximal end, conductors 326 are operably coupled to corresponding second (output) connectors 325a-e. As shown in FIG. 5B, input pins 321a-e are operably coupled to a signal portion of output connectors 325a-e, respectively, and input pin 321f is operably coupled in common to a ground portion of output connectors 325a-e. It is to be understood that the arrangement and correspondence of inputs and outputs may differ in various and alternative embodiments, particularly where disparate ECG leadwire assemblies are to be coupled to ECG devices that provide differing or non-standard ECG input connectors, as will be appreciated by the skilled artisan.

[0048] Housing 320 may be formed from any suitable electrically non-conductive material, including without limita-

tion polymeric material such as polyurethane, polypropylene, polyethylene, acrylonitrile butadiene styrene, polystyrene, polyvinyl chloride, polyacetal, polymethyl methacrylate and acetals. In embodiments, housing **320** may be fabricated by injection molding and/or overmolding around the components of ECG noise suppression adapter **300**, e.g., input pins **321a-f** and output connectors **325a-e**, that mechanically supports and electrically insulates the electrically conductive element(s) therewithin, e.g., toroidal inductor core **328**, and/or conductors **326**.

[0049] Turning now to FIG. 6, yet another embodiment of an ECG noise suppression adapter **400** is presented. ECG noise suppression adapter **400** includes a housing **420** having a first end **422** and a second end **424**. ECG noise suppression adapter **400** includes a noise suppression core **428** that has a generally open cylindrical shape and is formed from any material having suitable electromagnetic, coercivity, and permeability properties as previously described herein, such as, without limitation, ferrite and/or laminated iron. One or more ECG conductors **426** are coupled, at a distal end thereof, to one or more input terminals **421**, and at a proximal end thereof, to one or more output connectors **425**. In the present example, six ECG conductors **426** are shown wherein input terminals **421a-e** corresponding to ECG signals **1** through **5**, respectively, are operatively coupled by conductors **426a-e** to output connectors **425a-e**, respectively. Input terminal **421f** is coupled to a ground (e.g., shield) conductor **426f**, which, in turn, is coupled to common ground terminals of output connectors **425a-e**. Conductors **426a-f** pass through noise suppression core **428** to form a low pass choke, or filter, that exhibits high impedance at high frequencies typically associated with RFI as previously described.

[0050] One or more input terminals **421** are adapted to operably couple with one or more corresponding, mating pins disposed at a proximal end of ECG leadwire set (not explicitly shown) to receive ECG signals therefrom. Second end **424** includes one or more second connectors **425** adapted to mate with one or more corresponding connectors provided by an ECG device. At a proximal end, conductors **426a-f** are operably coupled to corresponding second (output) connectors **425a-e**. It is to be understood that the arrangement and correspondence of inputs and outputs may differ in various and alternative embodiments, particularly where disparate ECG leadwire assemblies are to be coupled to ECG devices that provide differing or non-standard ECG input connectors, as will be appreciated by the skilled artisan.

[0051] Housing **420** may be formed from any suitable electrically non-conductive material, including without limitation polymeric material such as polyurethane, polypropylene, polyethylene, or acrylonitrile butadiene styrene. In embodiments, housing **420** may be fabricated by injection molding and/or overmolding around the components of ECG noise suppression adapter **400**, e.g., input pins **421a-f** and output connectors **425a-e**, to mechanically support and electrically insulate the electrically conductive element(s) therewithin, e.g., noise suppression core **428**, and/or conductors **426**.

[0052] While several embodiments of the disclosure have been shown in the drawings and/or discussed herein, it is not intended that the disclosure be limited thereto, as it is intended that the disclosure be as broad in scope as the art will allow and that the specification be read likewise. Therefore, the above description should not be construed as limiting, but merely as exemplifications of particular embodiments. Those

skilled in the art will envision other modifications within the scope and spirit of the claims appended hereto.

What is claimed is:

1. A noise-suppressing ECG adapter, comprising:
  - a housing having a first end and a second end;
  - at least one first connector disposed at the first end of the housing, the at least one first connector adapted for operably coupling to a proximal end of ECG lead set;
  - at least one second connector disposed at the second end of the housing, the at least one second connector adapted for coupling to an input of an ECG device;
  - a noise suppression element disposed within the housing, the noise suppression element including one of a ferromagnetic element and an electromagnet having an opening defined therein; and
  - at least one conductor operably coupling the first connector and the second connector and passing through the opening of the one of the ferromagnetic element and the electromagnet.
2. The noise-suppressing ECG adapter according to claim 1, wherein the noise suppression element includes one of a low pass filter, a high pass filter, a notch filter, or a nyquist
3. The noise-suppressing ECG adapter according to claim 1, wherein the first connector includes a six-pin configuration.
4. The noise-suppressing ECG adapter according to claim 3, wherein the six-pin configuration comprises five signal pins and one ground pin.
5. The noise-suppressing ECG adapter according to claim 1, wherein the at least one second connector includes one signal pin and one ground pin.
6. The noise-suppressing ECG adapter according to claim 1, wherein the one of the ferromagnetic element and the electromagnet includes a shape selected from the group consisting of a toroid and an open cylinder.
7. The noise-suppressing ECG adapter according to claim 7, wherein the at least one conductor passes through the opening of the ferromagnetic element in a plurality of windings.
8. The noise-suppressing ECG adapter according to claim 1, wherein the noise suppression element is a ferromagnetic element formed from material selected from the group consisting of ferrite and laminated iron.
9. A noise-suppressing ECG system, comprising:
  - a noise-suppressing ECG adapter, comprising:
    - a housing having a first end and a second end;
    - at least one first connector disposed at the first end of the housing, the at least one first connector adapted for operably coupling to proximal end of ECG lead set;
    - at least one second connector disposed at the second end of the housing, the at least one second connector adapted for coupling to an input of an ECG device;
    - a noise suppression element disposed within the housing, the noise suppression element including one of a ferromagnetic element and an electromagnet having an opening defined therein; and
    - at least one conductor operably coupling the first connector and the second connector and passing through the opening of the one of the ferromagnetic element and the electromagnet; and
  - an ECG device adapted to operably couple to the at least one second connector of the noise-suppressing ECG adapter.

**10.** The noise-suppressing ECG system according to claim 9, further comprising an ECG lead set including a plurality of lead wires at a distal end of the ECG lead set configured to operably couple to a plurality of ECG pads, and an ECG connector disposed at a proximal end of ECG leadwire set.

**11.** The noise-suppressing ECG system according to claim 9, wherein the noise suppression element includes one of a low pass filter, a high pass filter, a notch filter and a nyquist filter.

**12.** The noise-suppressing ECG system according to claim 9, wherein the first connector includes a six-pin configuration.

**13.** The noise-suppressing ECG system according to claim 9, wherein the six-pin configuration comprises five signal pins and one ground pin.

**14.** The noise-suppressing ECG system according to claim 9, wherein the at least one second connector includes one signal pin and one ground pin.

**15.** The noise-suppressing ECG system according to claim 9, wherein the one of the ferromagnetic element and the electromagnet includes a shape selected from the group consisting of a toroid and an open cylinder.

**16.** The noise-suppressing ECG system according to claim 15, wherein the at least one conductor passes through the opening of the ferromagnetic element in a plurality of windings.

**17.** The noise-suppressing ECG system adapter according to claim 9, wherein the noise suppression element is a ferromagnetic element formed from material selected from the group consisting of ferrite and laminated iron.

**18-41.** (canceled)

\* \* \* \* \*

专利名称(译)	具有噪声抑制的ECG导联线系统及相关方法		
公开(公告)号	<a href="#">US20140221856A1</a>	公开(公告)日	2014-08-07
申请号	US14/135239	申请日	2013-12-19
[标]申请(专利权)人(译)	柯惠有限合伙公司		
申请(专利权)人(译)	COVIDIEN LP		
[标]发明人	CALLAHAN MARK J GILBERT GLENN COGGINS SCOTT R DELIA LINDA		
发明人	CALLAHAN, MARK J. GILBERT, GLENN COGGINS, SCOTT R. D'ELIA, LINDA		
IPC分类号	A61B5/0428 A61B5/00 A61B5/04		
CPC分类号	A61B5/04286 A61B5/7217 A61B5/04017 A61B5/0402 A61B2562/182 A61B2562/227 H01F17/06 H01F2017/065 H01R13/719 H01R31/065 H01R2201/12 H03H2001/005 H05K9/0066		
其他公开文献	US9375162		
外部链接	<a href="#">Espacenet</a> <a href="#">USPTO</a>		

摘要(译)

提出了具有第一端，第二端和噪声抑制元件的噪声抑制心电图（ECG）适配器，以及ECG噪声抑制系统和相关方法。在一个实施例中，所述噪声抑制ECG适配器包括壳体，所述壳体具有至少一个第一连接器，所述第一连接器设置在所述壳体的第一端，适于与ECG引线组电连接；以及至少一个第二连接器，适于连接到输入端。心电图设备。适配器包括噪声抑制元件。噪声抑制元件包括铁磁元件，铁磁元件具有限定在其中的开口。在一个实施例中，噪声抑制元件在适配器内部。在另一个实施例中，噪声抑制元件在适配器外部系留并且被配置为夹紧ECG导联线的至少一部分。

