



US 20190125427A1

(19) **United States**

(12) **Patent Application Publication**  
**Panescu**

(10) **Pub. No.: US 2019/0125427 A1**

(43) **Pub. Date: May 2, 2019**

(54) **HIGH-RESOLUTION MAPPING OF TISSUE WITH PACING**

*A61N 1/05* (2006.01)

*A61N 1/37* (2006.01)

(71) Applicant: **EPIX Therapeutics, Inc.**, Santa Clara, CA (US)

(52) **U.S. Cl.**

CPC ..... *A61B 18/1206* (2013.01); *A61N 1/36514* (2013.01); *A61B 5/042* (2013.01); *A61B 5/4836* (2013.01); *A61B 5/0402* (2013.01); *A61B 18/1492* (2013.01); *A61N 1/0565* (2013.01); *A61N 1/371* (2013.01); *A61B 18/14* (2013.01); *A61B 18/12* (2013.01)

(72) Inventor: **Dorin Panescu**, San Jose, CA (US)

(21) Appl. No.: **16/231,304**

(22) Filed: **Dec. 21, 2018**

(57)

**ABSTRACT**

According to some embodiments, a method of confirming successful ablation of targeted cardiac tissue of a subject using a high-resolution mapping electrode comprises pacing said cardiac tissue at a predetermined pacing level to increase the heart rate of the subject from a baseline level to an elevated level, the predetermined pacing level being greater than a pre-ablation pacing threshold level but lower than a post-ablation pacing threshold level, delivering ablative energy to the ablation electrode, detecting the heart rate of the subject, wherein the heart rate detected by the high-resolution mapping electrode is at the elevated level before the post-ablation pacing threshold level is achieved, and wherein the heart rate detected by the high-resolution mapping electrode drops below the elevated level once ablation achieves its therapeutic goal or target, and terminating the delivery of ablative energy to the ablation electrode after the heart rate drops below the elevated level.

**Related U.S. Application Data**

(63) Continuation of application No. 15/179,861, filed on Jun. 10, 2016, now Pat. No. 10,166,062, which is a continuation of application No. PCT/US2015/061360, filed on Nov. 18, 2015.

(60) Provisional application No. 62/081,710, filed on Nov. 19, 2014, provisional application No. 62/193,547, filed on Jul. 16, 2015.

**Publication Classification**

(51) **Int. Cl.**

*A61B 18/12* (2006.01)

*A61N 1/365* (2006.01)

*A61B 5/042* (2006.01)

*A61B 5/00* (2006.01)

*A61B 18/14* (2006.01)

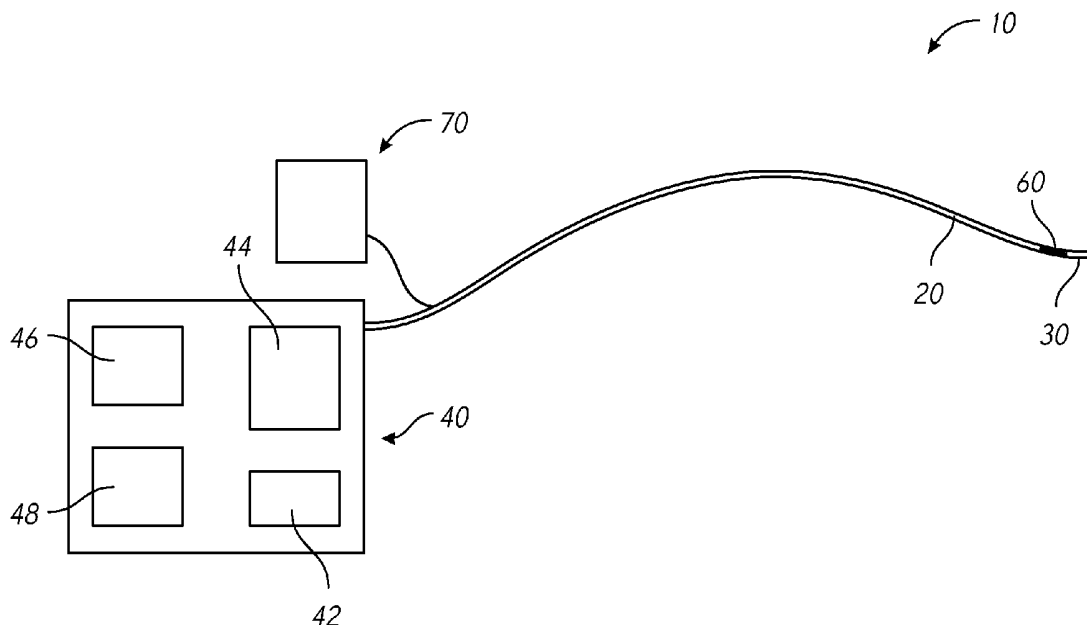

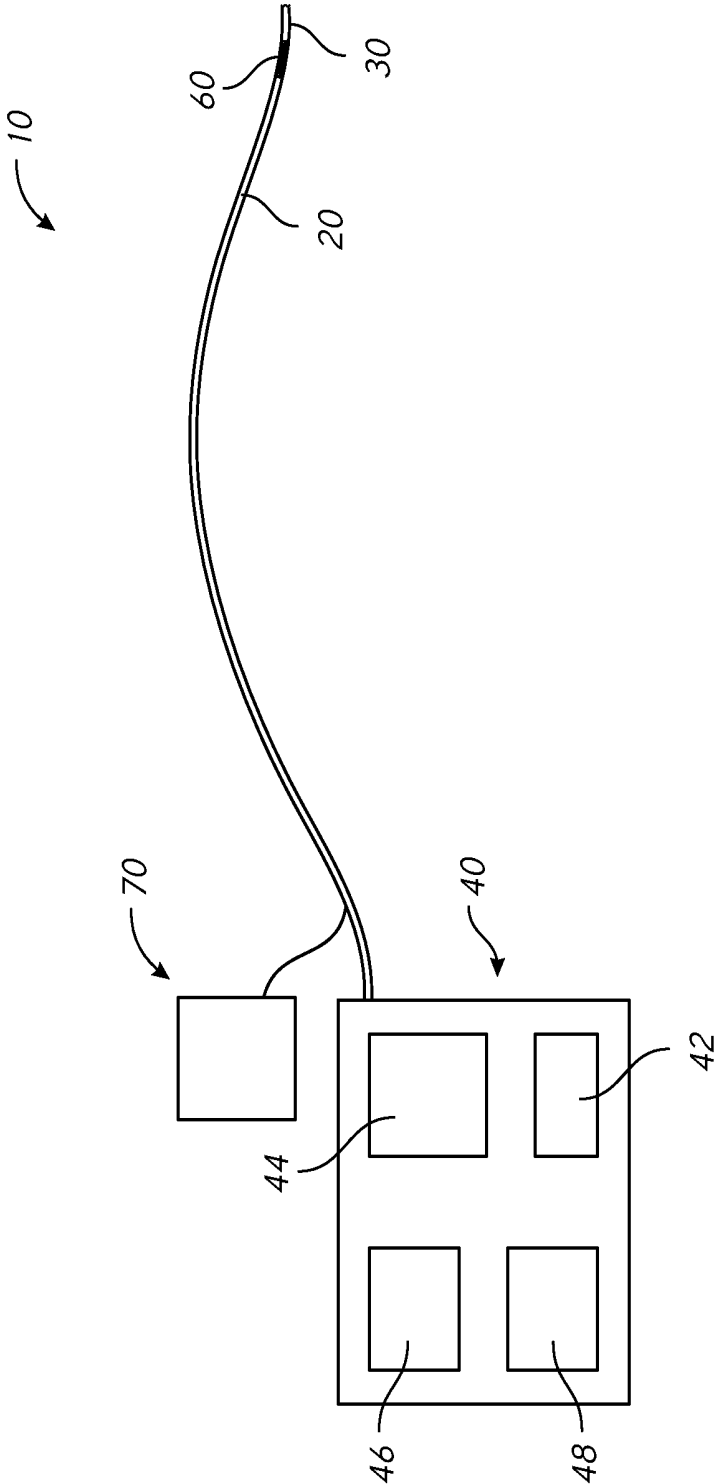

FIG. 1

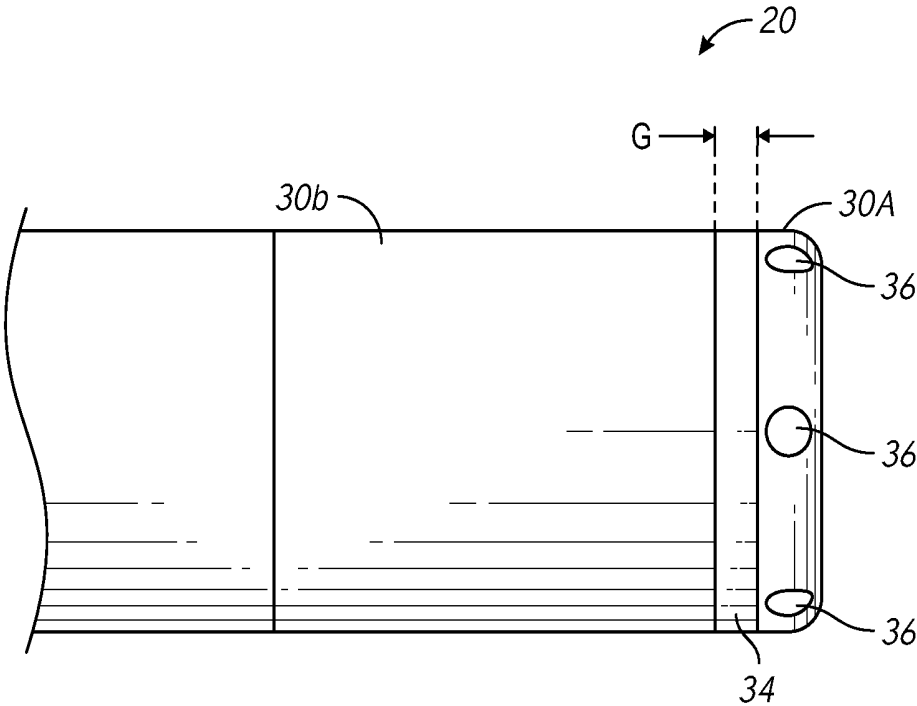

FIG. 2

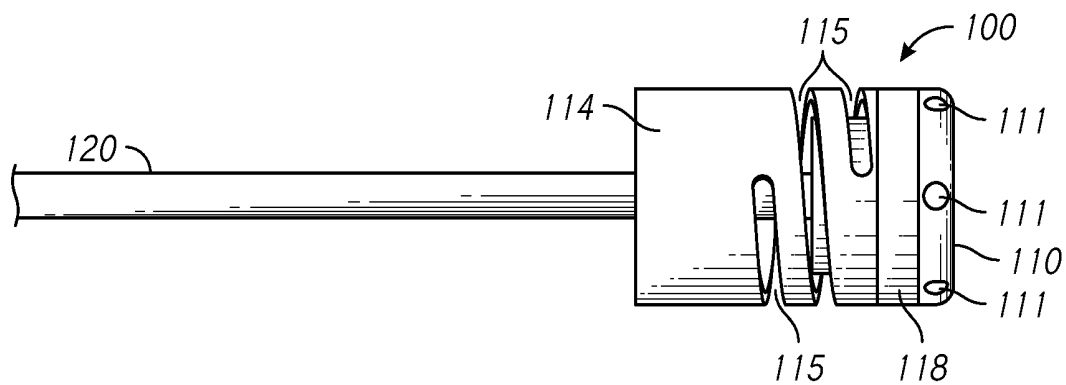

FIG. 3

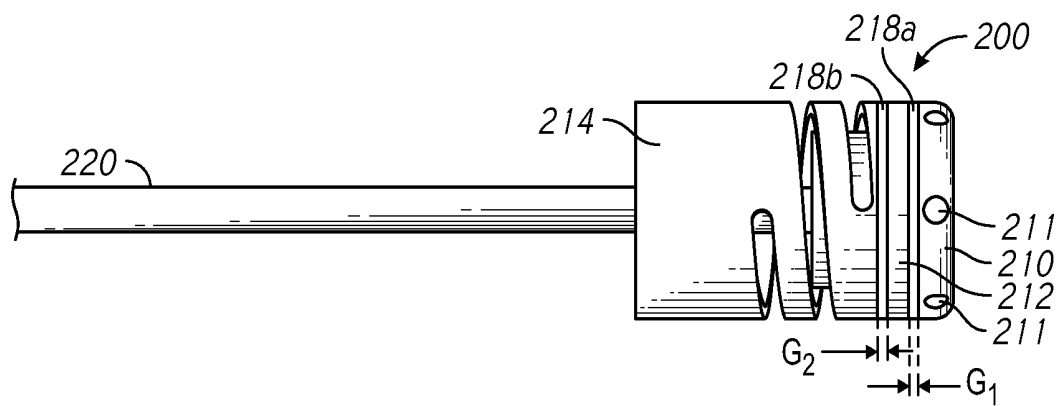

FIG. 4

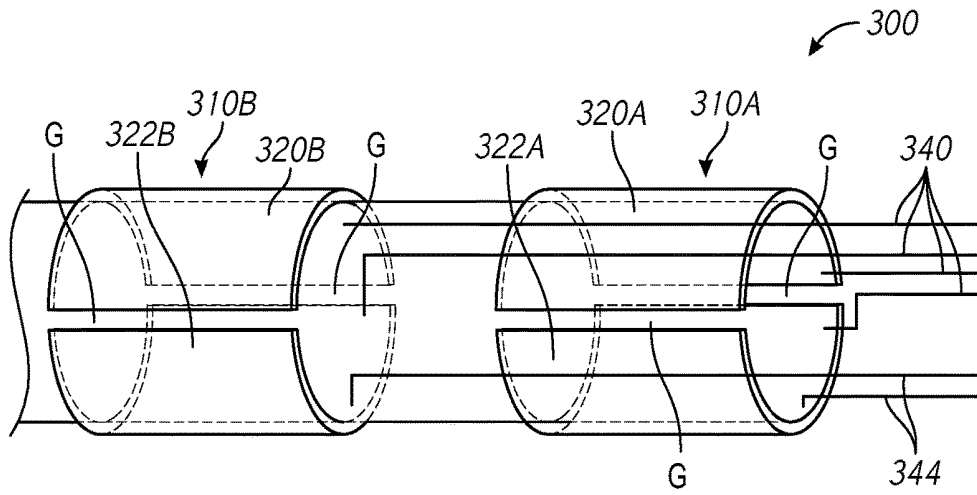

FIG. 5

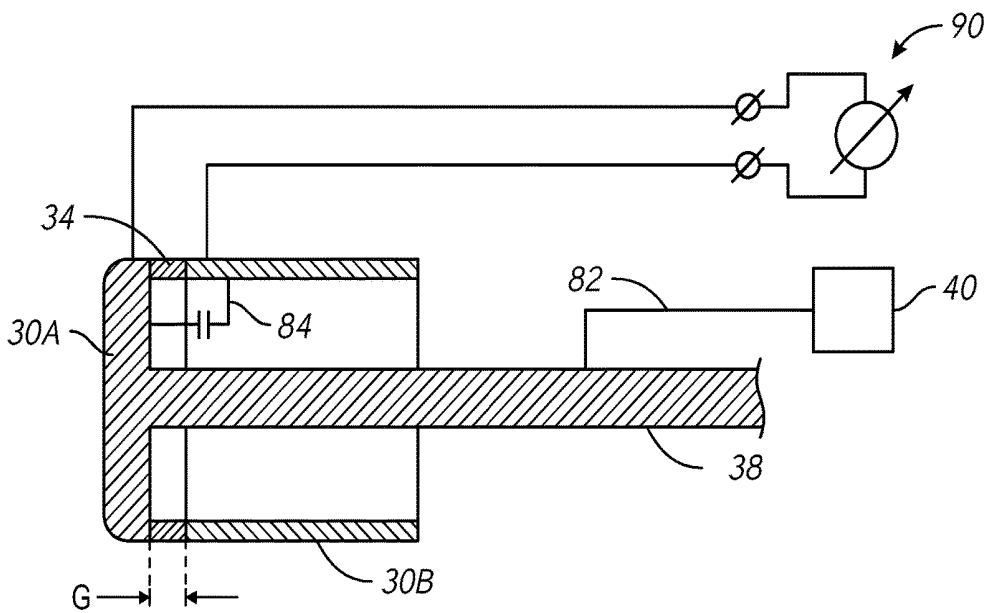

FIG. 6

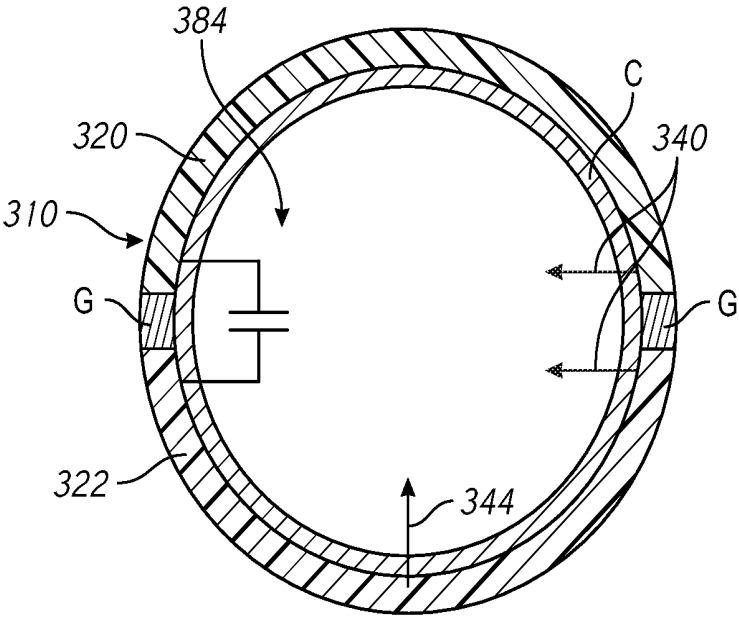

FIG. 7

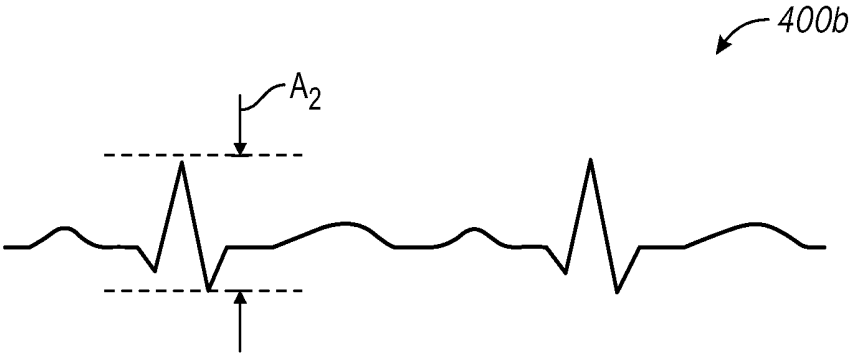
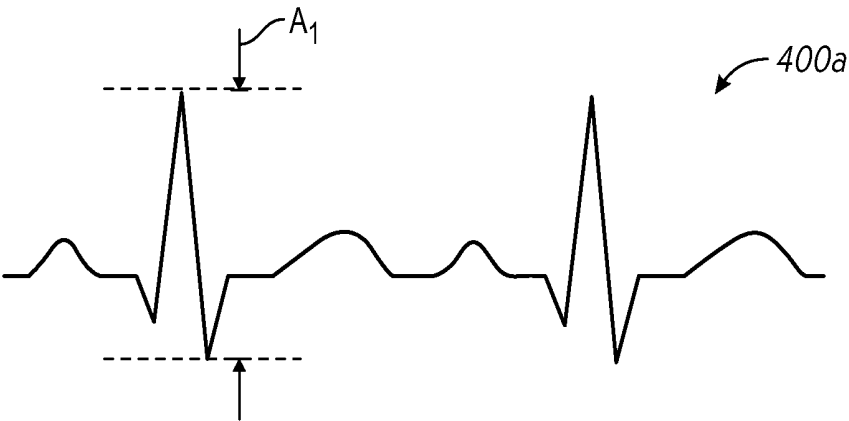

FIG. 8

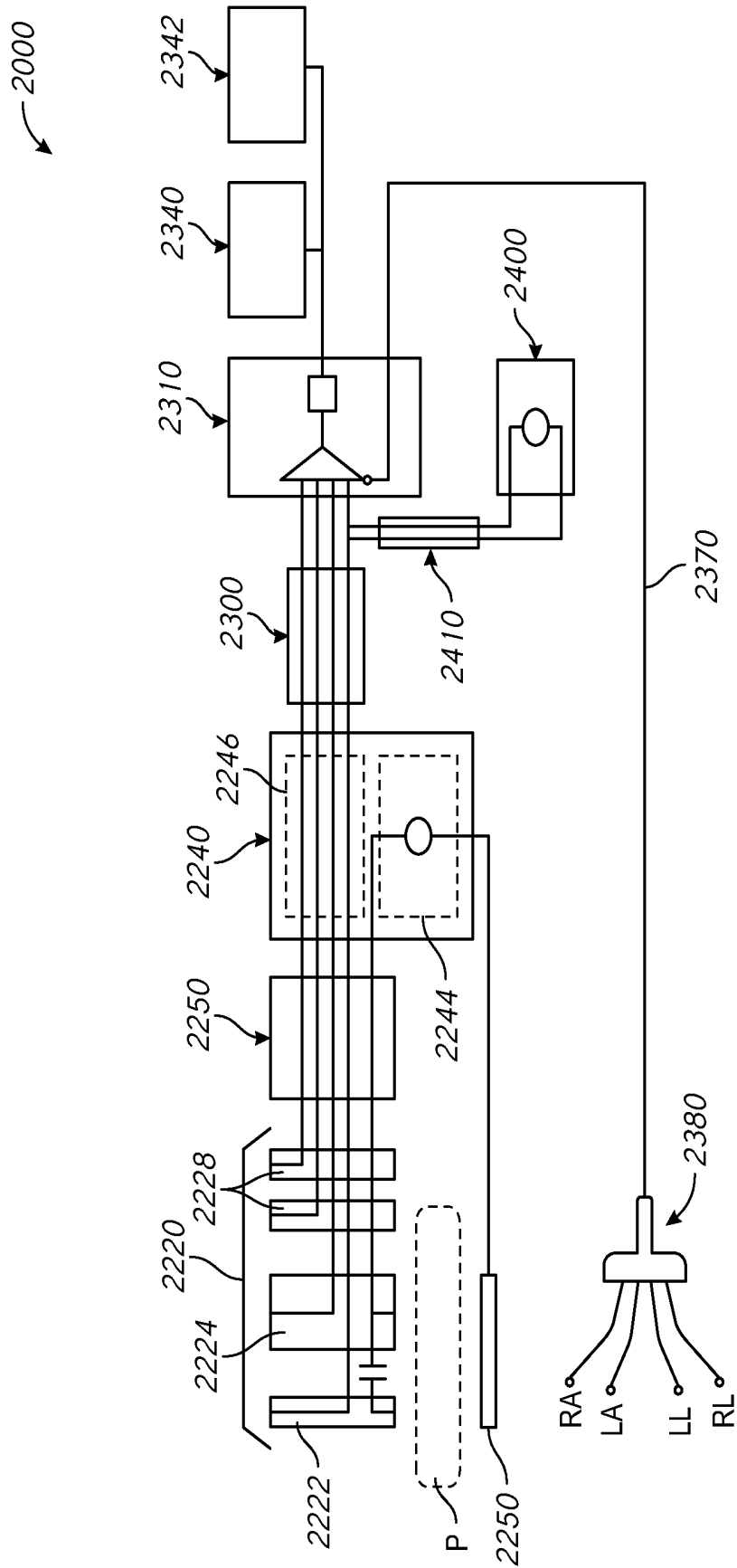

FIG. 9

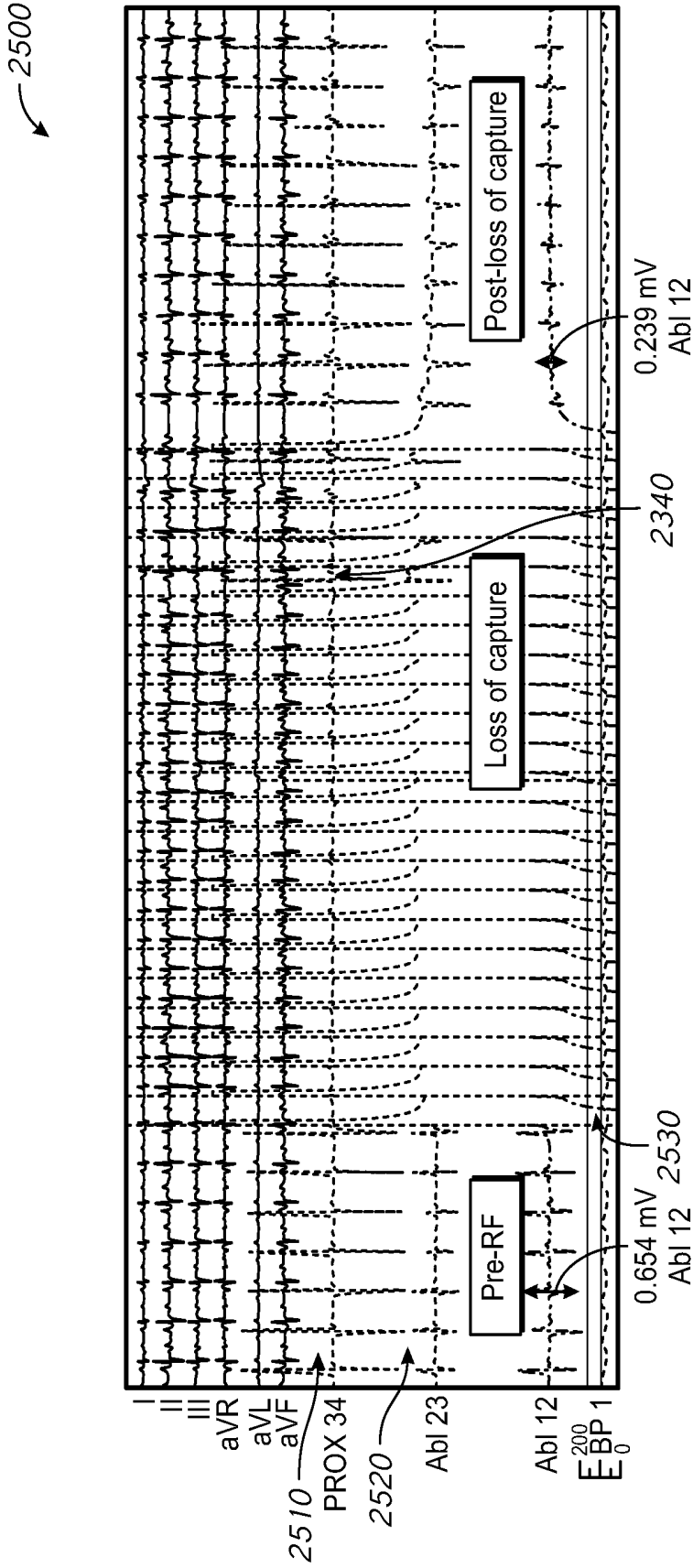

FIG. 10

## HIGH-RESOLUTION MAPPING OF TISSUE WITH PACING

### RELATED APPLICATIONS

[0001] This application is a continuation application of U.S. application Ser. No. 15/179,861 filed Jun. 10, 2016, which is a continuation of PCT/US2015/061360, filed Nov. 18, 2015, which claims priority to U.S. Provisional Application No. 62/081,710, filed Nov. 19, 2014, and U.S. Provisional Application No. 62/193,547, filed Jul. 16, 2015, the entire contents of each of which are incorporated herein by reference in their entirety.

### BACKGROUND

[0002] Tissue ablation may be used to treat a variety of clinical disorders. For example, tissue ablation may be used to treat cardiac arrhythmias by at least partially destroying (e.g., at least partially or completely ablating, interrupting, inhibiting, terminating conduction of, otherwise affecting, etc.) aberrant pathways that would otherwise conduct abnormal electrical signals to the heart muscle. Several ablation techniques have been developed, including cryoablation, microwave ablation, radio frequency (RF) ablation, and high frequency ultrasound ablation. For cardiac applications, such techniques are typically performed by a clinician who introduces a catheter having an ablative tip to the endocardium via the venous vasculature, positions the ablative tip adjacent to what the clinician believes to be an appropriate region of the endocardium based on tactile feedback, mapping electrocardiogram (ECG) signals, anatomy, and/or fluoroscopic imaging, actuates flow of an irrigant to cool the surface of the selected region, and then actuates the ablative tip for a period of time and at a power believed sufficient to destroy tissue in the selected region.

[0003] Successful electrophysiology procedures require precise knowledge about the anatomic substrate. Additionally, ablation procedures may be evaluated within a short period of time after their completion. Cardiac ablation catheters typically carry only regular mapping electrodes. Cardiac ablation catheters may incorporate high-resolution mapping electrodes. Such high-resolution mapping electrodes provide more accurate and more detailed information about the anatomic substrate and about the outcome of ablation procedures. High-resolution mapping electrodes can allow the electrophysiology to evaluate precisely the morphology of electrograms, their amplitude and width and to determine changes in pacing thresholds. Morphology, amplitude and pacing threshold are accepted and reliable electrophysiology (EP) markers that provide useful information about the outcome of ablation.

### SUMMARY

[0004] According to some embodiments, a system for delivering energy to targeted cardiac tissue of a subject and for confirming successful ablation of said targeted cardiac tissue comprises a medical instrument (e.g., catheter) comprising a high-resolution (e.g., split-tip) electrode along a distal end of the catheter, an energy delivery module comprising a processor, the energy delivery module being configured to operatively couple to the catheter, wherein the energy delivery module is configured to energize the electrode to selectively ablate targeted cardiac tissue adjacent the electrode, wherein the energy delivery module is con-

figured to couple to a pacemaker for selectively pacing cardiac tissue in order to attain capture of the heart of the subject, wherein the system is configured, via a predetermined pacing signal provided to the catheter by the pacemaker, to increase the heart rate of the subject from a baseline level to an elevated level, the predetermined pacing signal comprising a pacing level greater than a pre-ablation pacing threshold level, and wherein the processor is configured to terminate the delivery of energy to the electrode after loss of capture of the heart of the subject.

[0005] According to some embodiments, wherein the pacemaker is included in the system, the pacemaker is integral to the energy delivery module. In some embodiments, the energy delivery module is configured to deliver radiofrequency (RF) energy to the electrode, wherein the energy delivery module comprises a radiofrequency (RF) generator, wherein the high-resolution electrode comprises a distal portion and a proximal portion, the distal and proximal portions of the high-resolution electrode being operatively coupled to each other using at least one filtering element, wherein the filtering element comprises a capacitor, wherein the pacing level of predetermined pacing signal is 5 to 20 milliamps (mA), wherein the elevated level of the heart rate upon pacing the cardiac tissue at the predetermined pacing level is 100 to 200 beats per minute (bpm), and wherein the energy delivery module comprises at least one filter, the at least one filter being configured to isolate a signal relating to the localized heart rate signal measured using the high-resolution mapping electrode.

[0006] According to some embodiments, the pacemaker is included in the system, wherein the high-resolution electrode comprises a distal portion and a proximal portion, the distal and proximal portions of the high-resolution electrode being operatively coupled to each other using at least one filtering element, wherein the filtering element comprises a capacitor, wherein the pacing level of predetermined pacing signal is 5 to 20 milliamps (mA), and wherein the elevated level of the heart rate upon pacing the cardiac tissue at the predetermined pacing level is 100 to 200 beats per minute (bpm).

[0007] According to some embodiments, the pacemaker is integral to the energy delivery module. In some embodiments, the pacemaker is separate from the energy delivery module. In some arrangements, the pacemaker is included in the system. In some embodiments, the pacemaker is not included in the system. In some embodiments, the energy delivery module is configured to deliver radiofrequency (RF) energy to the electrode. In some embodiments, the high-resolution electrode comprises a distal portion and a proximal portion, the distal and proximal portions of the high-resolution electrode being operatively coupled to each other using at least one filtering element. In some embodiments, the at least one filtering element comprises a capacitor.

[0008] According to some embodiments, the catheter further comprises at least one additional mapping electrode. In some embodiments, the energy delivery module comprises a radiofrequency (RF) generator. In some embodiments, the energy delivery module comprises at least one filter, the at least one filter being configured to isolate a signal relating to the localized heart rate signal measured using the high-resolution mapping electrode. In some embodiments, the pacing level of predetermined pacing signal is 5 to 20 milliamps (mA) (e.g., 5-6, 6-7, 7-8, 8-9, 9-10, 10-11, 11-12,

12-13, 13-14, 14-15, 15-16, 16-17, 17-18, 18-19, 19-20 mA, etc.). In some embodiments, the pacing level of predetermined pacing signal is 10 to 15 milliamps (mA).

**[0009]** According to some embodiments, the elevated level of the heart rate upon pacing the cardiac tissue at the predetermined pacing level is 100 to 200 beats per minute (bpm) (e.g., e.g., 100-105, 105-110, 110-115, 115-120, 120-125, 125-130, 130-135, 135-140, 140-145, 145-150, 150-155, 155-160, 160-165, 165-170, 170-175, 175-180, 180-185, 185-190, 190-195, 195-200 bpm, etc.). In some embodiments, the elevated level of the heart rate upon pacing the cardiac tissue at the predetermined pacing level is 120 to 150 beats per minute (bpm). In some embodiments, the pre-ablation pacing threshold level is 0.1 to 3 milliamps (mA) (e.g., 0.1-0.2, 0.2-0.3, 0.3-0.4, 0.4-0.5, 0.5-0.6, 0.6-0.7, 0.7-0.8, 0.8-0.9, 0.9-1.0, 1.0-1.1, 1.1-1.2, 1.2-1.3, 1.3-1.4, 1.4-1.5, 1.5-1.6, 1.6-1.7, 1.7-1.8, 1.8-1.9, 1.9-2, 2-2.5, 2.5-3 mA, etc.). In some embodiments, the pre-ablation pacing threshold level is 0.5 to 2 milliamps (mA).

**[0010]** According to some embodiments, the processor is configured to terminate the delivery of energy to the electrode as soon as the heart rate drops below the elevated level or after loss of capture of the heart of the subject. In some embodiments, the processor is configured to terminate the delivery of energy to the electrode following a pre-determined time period after the heart rate drops below the elevated level or after loss of capture of the heart of the subject. In some embodiments, the predetermined time period comprises 0.5 to 10 seconds (e.g., 0.5-1, 1-2, 2-3, 3-4, 4-5, 5-6, 6-7, 7-8, 8-9, 9-10 seconds, values between the foregoing ranges, etc.). In some embodiments, the predetermined time period comprises 1 to 5 seconds.

**[0011]** According to some embodiments, delivery of energy is terminated by an operator with or without a time period after the heart rate drops below the elevated level or after loss of capture of the heart of the subject. In some embodiments, the system further includes at least one output configured to receive data related to the subject's heart rate. In some embodiments, the at least one output comprises a display (e.g., a monitor or other display, etc.). In some embodiments, the at least one output is integrated within the system. In other configurations, the at least one output is separate from the system. In some embodiments, data related to the subject's heart rate are provided via and processed by an EP recording system.

**[0012]** According to some embodiments, a method of ablating and confirming successful ablation of targeted cardiac tissue of a subject using a high-resolution mapping electrode includes pacing said cardiac tissue at a predetermined pacing level to capture the heart of the subject, thereby increasing a heart rate of the subject from a baseline level to an elevated level, delivering ablative energy to the ablation electrode while pacing, the ablation electrode comprising a high-resolution electrode (e.g., a split-tip electrode), wherein the predetermined pacing level exceeds a pre-ablation threshold level, wherein capture of the heart of the subject occurs once the pacing level exceeds the pre-ablation level, and wherein the heart rate of the subject drops below the elevated level when capture of the heart of the subject is lost. The method additionally includes terminating the delivery of ablative energy to the ablation electrode after capture of the heart of the subject is lost.

**[0013]** According to some embodiments, a method of confirming successful ablation of targeted cardiac tissue of

a subject using a high-resolution mapping electrode includes pacing said cardiac tissue at a predetermined pacing level to increase a heart rate of the subject from a baseline level to an elevated level, the predetermined pacing level being greater than a pre-ablation pacing threshold level and less than a post-ablation pacing threshold level, delivering ablative energy to the ablation electrode while pacing, the ablation electrode comprising a high-resolution electrode, wherein the heart rate of the subject is at the elevated level once the pre-ablation threshold level is exceeded, but before the post-ablation pacing threshold level is reached, and wherein the heart rate of the subject drops below the elevated level once the ablation electrode has successfully ablated adjacent tissue of the subject, the heart rate has dropped below the elevated level as the post-ablation pacing threshold level is greater than the predetermined pacing level. The method additionally comprises terminating the delivery of ablative energy to the ablation electrode after the heart rate of the subject drops below the elevated level.

**[0014]** According to some embodiments, pacing cardiac tissue is performed via an energy delivery module that is configured to deliver ablative energy to the ablation electrode. In some embodiments, the energy delivery module comprises a radiofrequency (RF) generator. In some embodiments, pacing the cardiac tissue comprises operatively coupling a pacemaker to an energy delivery module that is configured to deliver ablative energy to the ablation electrode. In some embodiments, the pacemaker is integral with the energy delivery module (e.g., RF generator). In some embodiments, the pacemaker is separate from the energy delivery module.

**[0015]** According to some embodiments, the predetermined pacing level is 5 to 20 milliamps (mA) (e.g., 5-6, 6-7, 7-8, 8-9, 9-10, 10-11, 11-12, 12-13, 13-14, 14-15, 15-16, 16-17, 17-18, 18-19, 19-20 mA, etc.). In some embodiments, the pacing threshold is 10 to 15 milliamps (mA). In some embodiments, the elevated level of the heart rate upon pacing the cardiac tissue at the predetermined pacing level is 100 to 200 beats per minute (bpm) (e.g., e.g., 100-105, 105-110, 110-115, 115-120, 120-125, 125-130, 130-135, 135-140, 140-145, 145-150, 150-155, 155-160, 160-165, 165-170, 170-175, 175-180, 180-185, 185-190, 190-195, 195-200 bpm, etc.). In some embodiments, the elevated level of the heart rate upon pacing the cardiac tissue at the predetermined pacing level is 120 to 150 beats per minute (bpm). In some embodiments, the pre-ablation pacing threshold level is 0.1 to 3 milliamps (mA) (e.g., 0.1-0.2, 0.2-0.3, 0.3-0.4, 0.4-0.5, 0.5-0.6, 0.6-0.7, 0.7-0.8, 0.8-0.9, 0.9-1.0, 1.0-1.1, 1.1-1.2, 1.2-1.3, 1.3-1.4, 1.4-1.5, 1.5-1.6, 1.6-1.7, 1.7-1.8, 1.8-1.9, 1.9-2, 2-2.5, 2.5-3 mA, etc.). In some embodiments, the pre-ablation pacing threshold level is 0.5 to 2 milliamps (mA). In some embodiments, the post-ablation pacing threshold level is greater than 10 milliamps (mA). In some embodiments, the post-ablation pacing threshold level is greater than 20 milliamps (mA).

**[0016]** According to some embodiments, terminating the delivery of ablative energy to the ablation electrode occurs immediately after the heart rate of the subject drops below the elevated level or after capture of the heart of the subject is lost. In some embodiments, terminating the delivery of ablative energy to the ablation electrode occurs following a predetermined time period after the heart rate of the subject drops below the elevated level or after capture of the heart of the subject is lost. In some embodiments, the predeter-

mined time period comprises 0.5 to 10 seconds (e.g., 0.5-1, 1-2, 2-3, 3-4, 4-5, 5-6, 6-7, 7-8, 8-9, 9-10 seconds, values between the foregoing ranges, etc.). In some embodiments, the predetermined time period comprises 1 to 5 seconds. In some embodiments, delivery of energy is terminated by an operator with or without a time period after the heart rate drops below the elevated level or after loss of capture of the heart of the subject.

**[0017]** According to some embodiments, the method additional includes providing data related to the heart rate of the subject to at least one output. In some embodiments, the at least one output comprises a display (e.g., display, other monitor, etc.). In some embodiments, data related to the heart rate of the subject are provided via and processed by an electrophysiology (EP) recording system. In some embodiments, delivering ablative energy to the ablation electrode comprises delivering radiofrequency (RF) energy.

**[0018]** According to some embodiments, a system for delivering energy to targeted cardiac tissue of a subject and for confirming successful ablation of said targeted cardiac tissue comprises a catheter comprising a high-resolution electrode along a distal end of the catheter, an energy delivery module (e.g., generator) comprising a processor, the energy delivery module being configured to operatively couple to the catheter, wherein the energy delivery module is configured to energize the electrode to selectively ablate targeted cardiac tissue adjacent the electrode, wherein the energy delivery module is configured to couple to a pacemaker for selectively pacing cardiac tissue in order to selectively increase a heart rate of the subject, wherein the system is configured, via a predetermined pacing signal provided to the catheter by the pacemaker, to increase the heart rate of the subject from a baseline level to an elevated level, the predetermined pacing signal comprising a pacing level greater than a pre-ablation pacing threshold level and less than a post-ablation pacing threshold level, wherein a heart rate of the subject is at the elevated level before the post-ablation pacing threshold level is achieved, wherein a heart rate of the subject falls below the elevated level once the high-resolution electrode has ablated adjacent tissue to a target therapeutic level, and wherein the processor is configured to terminate the delivery of energy to the electrode after the subject's heart rate drops below the elevated level.

**[0019]** According to some embodiments, the pacemaker is integral to the energy delivery module. In some embodiments, the pacemaker is separate from the energy delivery module. In some embodiments, the pacemaker is included in the system. In some configurations, the pacemaker is not included in the system.

**[0020]** According to some embodiments, the energy delivery module is configured to deliver radiofrequency (RF) energy to the electrode. In some embodiments, the electrode comprises a high-resolution electrode having a distal portion and a proximal portion, the distal and proximal portions of the high-resolution electrode being operatively coupled to each other using at least one filtering element. In some embodiments, the at least one filtering element comprises a capacitor.

**[0021]** According to some embodiments, the catheter further comprises at least one additional mapping electrode. In some embodiments, the energy delivery module comprises a radiofrequency (RF) generator. In some embodiments, the energy delivery module comprises at least one filter, the at least one filter being configured to isolate a signal relating to

the localized heart rate signal measured using the high-resolution mapping electrode.

**[0022]** According to some embodiments, the predetermined pacing level is 5 to 20 milliamps (mA) (e.g., 5-6, 6-7, 7-8, 8-9, 9-10, 10-11, 11-12, 12-13, 13-14, 14-15, 15-16, 16-17, 17-18, 18-19, 19-20 mA, etc.). In some embodiments, the pacing threshold is 10 to 15 milliamps (mA). In some embodiments, the elevated level of the heart rate upon pacing the cardiac tissue at the predetermined pacing level is 100 to 200 beats per minute (bpm) (e.g., e.g., 100-105, 105-110, 110-115, 115-120, 120-125, 125-130, 130-135, 135-140, 140-145, 145-150, 150-155, 155-160, 160-165, 165-170, 170-175, 175-180, 180-185, 185-190, 190-195, 195-200 bpm, etc.). In some embodiments, the elevated level of the heart rate upon pacing the cardiac tissue at the predetermined pacing level is 120 to 150 beats per minute (bpm). In some embodiments, the pre-ablation pacing threshold level is 0.1 to 3 milliamps (mA) (e.g., 0.1-0.2, 0.2-0.3, 0.3-0.4, 0.4-0.5, 0.5-0.6, 0.6-0.7, 0.7-0.8, 0.8-0.9, 0.9-1.0, 1.0-1.1, 1.1-1.2, 1.2-1.3, 1.3-1.4, 1.4-1.5, 1.5-1.6, 1.6-1.7, 1.7-1.8, 1.8-1.9, 1.9-2, 2-2.5, 2.5-3 mA, etc.). In some embodiments, the pre-ablation pacing threshold level is 0.5 to 2 milliamps (mA). In some embodiments, the post-ablation pacing threshold level is greater than 10 milliamps (mA). In some embodiments, the post-ablation pacing threshold level is greater than 20 milliamps (mA).

**[0023]** According to some embodiments, the processor is configured to terminate the delivery of energy to the electrode as soon as the heart rate drops below the elevated level or after loss of capture of the heart of the subject. In some embodiments, the processor is configured to terminate the delivery of energy to the electrode following a pre-determined time period after the heart rate drops below the elevated level or after loss of capture of the heart of the subject. In some embodiments, the predetermined time period comprises 0.5 to 10 seconds (e.g., 0.5-1, 1-2, 2-3, 3-4, 4-5, 5-6, 6-7, 7-8, 8-9, 9-10 seconds, values between the foregoing ranges, etc.). In some embodiments, the predetermined time period comprises 1 to 5 seconds.

**[0024]** According to some embodiments, the system is configured so that delivery of energy is terminated by an operator with or without a time period after the heart rate drops below the elevated level or after loss of capture of the heart of the subject. In some embodiments, the system further comprises at least one output configured to receive data related to the subject's heart rate. In some embodiments, the at least one output comprises a display (e.g., monitor, other display, etc.). In some embodiments, the at least one output is integrated within the system. In other configurations, the at least one output is separate from the system.

**[0025]** According to some embodiments, data related to the subject's heart rate are provided via and processed by an EP recording system. In some embodiments, the post-ablation pacing threshold level is greater than 10 milliamps (mA). In some arrangements, the post-ablation pacing threshold level is greater than 20 milliamps (mA).

**[0026]** According to some embodiments, an energy delivery module (e.g., a generator) configured to deliver ablative energy to targeted cardiac tissue of a subject and for confirming successful ablation of said targeted cardiac tissue includes a processor for regulating the delivery of ablative energy, wherein the energy delivery module is configured to operatively couple to a catheter, wherein the energy delivery

module is configured to energize an electrode positioned along a distal end of the catheter to selectively ablate targeted cardiac tissue adjacent the electrode, wherein the energy delivery module is configured to couple to a pacemaker for selectively pacing cardiac tissue in order to attain capture of the heart of the subject, wherein the processor is configured, via a predetermined pacing signal provided to the catheter by a pacemaker, to increase the heart rate of the subject from a baseline level to an elevated level, the predetermined pacing signal comprising a pacing level greater than a pre-ablation pacing threshold level, and wherein the processor is configured to terminate the delivery of energy to the electrode after loss of capture of the heart of the subject.

**[0027]** According to some embodiments, the energy delivery module further comprises a pacemaker. In some embodiments, the pacemaker is integrated within the module. In some embodiments, the pacemaker is separate from the module.

**[0028]** According to some embodiments, a kit for delivering ablative energy to targeted cardiac tissue of a subject and for confirming successful ablation of said targeted cardiac tissue comprises a catheter including a high-resolution electrode (e.g., a split-tip electrode) along a distal end of the catheter, and an energy delivery module comprising a processor, wherein the processor is configured to regulate the delivery of ablative energy, wherein the energy delivery module is configured to operatively couple to the catheter, wherein the energy delivery module is configured to energize the electrode positioned along a distal end of the catheter to selectively ablate targeted cardiac tissue adjacent the electrode, wherein the energy delivery module is configured to couple to a pacemaker for selectively pacing cardiac tissue in order to attain capture of the heart of the subject, wherein the processor is configured, via a predetermined pacing signal provided to the catheter by a pacemaker, to increase the heart rate of the subject from a baseline level to an elevated level, the predetermined pacing signal comprising a pacing level greater than a pre-ablation pacing threshold level, and wherein the processor is configured to terminate the delivery of energy to the electrode after loss of capture of the heart of the subject.

**[0029]** According to some embodiments, the kit further comprises the pacemaker. In some embodiments, the pacemaker is integrated within the energy delivery module. In other configurations, the pacemaker is separate from the energy delivery module. In one embodiment, the energy delivery module is configured to receive (e.g., via a port, coupling, other wired connection, a wireless connection, etc.) a pacemaker.

**[0030]** According to some embodiments, a processor configured for use with an energy delivery module configured to deliver ablative energy to targeted cardiac tissue of a subject and for confirming successful ablation of said targeted cardiac tissue is configured to regulate the delivery of ablative energy from an energy delivery module to an electrode, wherein the energy delivery module is configured to operatively couple to a catheter comprising the electrode, wherein the energy delivery module is configured to energize the electrode positioned along a distal end of the catheter to selectively ablate targeted cardiac tissue adjacent the electrode, wherein the processor is configured to couple to a pacemaker for selectively pacing cardiac tissue in order to attain capture of the heart of the subject, wherein the

processor is configured, via a predetermined pacing signal provided to the catheter by a pacemaker, to increase the heart rate of the subject from a baseline level to an elevated level, the predetermined pacing signal comprising a pacing level greater than a pre-ablation pacing threshold level, and wherein the processor is configured to terminate the delivery of energy to the electrode after loss of capture of the heart of the subject. According to some embodiments, the processor is directly or indirectly coupled to a pacemaker.

**[0031]** According to some embodiments, a generator configured to deliver ablative energy to targeted cardiac tissue of a subject and for confirming successful ablation of said targeted cardiac tissue comprises an energy delivery module configured to generate ablative energy for delivery to an ablation device, and a processor configured to regulate the delivery of ablative energy from the energy delivery module to an electrode of the ablation device, wherein ablative energy generated by the energy delivery module is delivered to the electrode assembly, wherein the energy delivery module is configured to couple to a pacemaker for selectively pacing cardiac tissue in order to attain capture of the heart of the subject, wherein the processor is configured, via a predetermined pacing signal provided to the catheter by a pacemaker, to increase the heart rate of the subject from a baseline level to an elevated level, the predetermined pacing signal comprising a pacing level greater than a pre-ablation pacing threshold level, and wherein the processor is configured to terminate the delivery of energy to the electrode after loss of capture of the heart of the subject.

**[0032]** According to some embodiments, the energy delivery module is configured to generate radiofrequency (RF) energy. In some embodiments, the processor and the energy delivery module are located within a single housing or enclosure. In some embodiments, the processor and the energy delivery module are located within separate housings or enclosures. In some embodiments, the generator includes the pacemaker. In some embodiments, the pacemaker is integral to the energy delivery module. In other arrangements, the pacemaker is separate from the energy delivery module.

**[0033]** According to some embodiments, the electrode comprises a high-resolution electrode (e.g., split-tip electrode). In some embodiments, the high resolution electrode comprises a distal portion and a proximal portion, the distal and proximal portions of the high-resolution electrode being operatively coupled to each other using at least one filtering element. In some embodiments, the at least one filtering element comprises a capacitor.

#### BRIEF DESCRIPTION OF THE DRAWINGS

**[0034]** These and other features, aspects and advantages of the present application are described with reference to drawings of certain embodiments, which are intended to illustrate, but not to limit, the concepts disclosed herein. The attached drawings are provided for the purpose of illustrating concepts of at least some of the embodiments disclosed herein and may not be to scale.

**[0035]** FIG. 1 schematically illustrates one embodiment of an energy delivery system configured to selectively ablate or otherwise heat targeted tissue of a subject;

**[0036]** FIG. 2 illustrates a side view of a system's catheter comprising a high-resolution-tip design according to one embodiment;

[0037] FIG. 3 illustrates a side view of a system's catheter comprising a high-resolution-tip design according to another embodiment;

[0038] FIG. 4 illustrates a side view of a system's catheter comprising a high-resolution-tip design according to yet another embodiment;

[0039] FIG. 5 illustrates an embodiment of a system's catheter comprising two high-resolution-section electrodes each consisting of separate sections circumferentially distributed on the catheter shaft;

[0040] FIG. 6 schematically illustrates one embodiment of a high-pass filtering element consisting of a coupling capacitor. The filtering element can be incorporated into a system's catheter that comprises a high-resolution-tip design;

[0041] FIG. 7 schematically illustrates one embodiment of four high-pass filtering elements comprising coupling capacitors. The filtering elements can operatively couple, in the operating RF frequency range, the separate electrode sections of a system's catheter electrodes, e.g., those illustrated in FIG. 5;

[0042] FIG. 8 illustrates embodiments of EKGs obtained from a high-resolution-tip electrode systems disclosed herein configured to detect whether an ablation procedure has been adequately performed;

[0043] FIG. 9 schematically illustrates one embodiment of a mapping and ablation system configured for cardiac pacing; and

[0044] FIG. 10 illustrates one embodiment of a graphical output using a mapping and ablation system, such as the system schematically depicted in FIG. 9.

#### DETAILED DESCRIPTION

[0045] According to some embodiments, successful electrophysiology procedures require precise knowledge about the anatomic substrate being targeted. Additionally, it may be desirable to evaluate the outcome of an ablation procedure within a short period of time after the execution of the procedure (e.g., to confirm that the desired clinical outcome was achieved). Typically, ablation catheters include only regular mapping electrodes (e.g., ECG electrodes). However, in some embodiments, it may be desirable for such catheters to incorporate high-resolution mapping capabilities. In some embodiments, high-resolution mapping electrodes can provide more accurate and more detailed information about the anatomic substrate and about the outcome of ablation procedures. For example, such high-resolution mapping electrodes can allow the electrophysiology (EP) practitioner to evaluate the morphology of electrograms, their amplitude and width and/or to determine changes in pacing thresholds. According to some arrangements, morphology, amplitude and/or pacing threshold are accepted as reliable EP markers that provide useful information about the outcome of ablation. Thus, high-resolution electrodes are defined as any electrode(s) capable of delivering ablative or other energy to tissue capable of transferring heat to/from such tissue, while being capable of obtaining accurate mapping data of adjacent tissue, and include, without limitation, split-tip RF electrodes, other closely oriented electrodes or electrode portions and/or the like.

[0046] Several embodiments disclosed herein are particularly advantageous because they include one, several or all of the following benefits or advantages: reducing proximal edge heating, reducing the likelihood of char formation, providing for feedback that may be used to adjust ablation

procedures in real time, providing noninvasive temperature measurements, providing safer and more reliable ablation procedures, providing for confirmation that a targeted region of tissue being treated has been properly ablated (e.g., using confirmation related to capture of the heart) and/or the like.

[0047] According to some embodiments, various implementations of electrodes (e.g., radiofrequency or RF electrodes) that can be used for high-resolution mapping are disclosed herein. For example, as discussed in greater detail herein, an ablation or other energy delivery system can comprise a high-resolution-tip design, wherein the energy delivery member (e.g., radiofrequency electrode) comprises two or more separate electrodes or electrode portions. As also discussed herein, in some embodiments, such separate electrodes or electrode portions can be advantageously electrically coupled to each other (e.g., to collectively create the desired heating or ablation of targeted tissue).

[0048] FIG. 1 schematically illustrates one embodiment of an energy delivery system 10 that is configured to selectively ablate, stimulate, modulate and/or otherwise heat or treat targeted tissue (e.g., cardiac tissue, pulmonary vein, other vessels or organs, etc.). Although certain embodiments disclosed herein are described with reference to ablation systems and methods, any of the systems and methods can be used to stimulate, modulate, heat and/or otherwise affect tissue, with or without partial or complete ablation, as desired or required. As shown, the system 10 can include a medical instrument 20 (e.g., catheter) comprising one or more energy delivery members 30 (e.g., radiofrequency electrodes) along a distal end of the medical instrument 20. The medical instrument can be sized, shaped and/or otherwise configured to be passed intraluminally (e.g., intravascularly) through a subject being treated. In various embodiments, the medical instrument 20 comprises a catheter, a shaft, a wire, and/or other elongate instrument. In other embodiments, the medical instrument is not positioned intravascularly but is positioned extravascularly via laparoscopic or open surgical procedures. In various embodiments, the medical instrument 20 comprises a catheter, a shaft, a wire, and/or other elongate instrument. In some embodiments, one or more temperature sensing devices or systems 60 (e.g., thermocouples, thermistors, etc.) may be included at the distal end of the medical instrument 20, or along its elongate shaft or in its handle. The term "distal end" does not necessarily mean the distal terminus or distal end. Distal end could mean the distal terminus or a location spaced from the distal terminus but generally at a distal end portion of the medical instrument 20.

[0049] In some embodiments, the medical instrument 20 is operatively coupled to one or more devices or components. For example, as depicted in FIG. 1, the medical instrument 20 can be coupled to a delivery module 40 (such as an energy delivery module). According to some arrangements, the energy delivery module 40 includes an energy generation device 42 that is configured to selectively energize and/or otherwise activate the energy delivery member(s) 30 (for example, radiofrequency electrodes) located along the medical instrument 20. In some embodiments, for instance, the energy generation device 42 comprises a radiofrequency generator, an ultrasound energy source, a microwave energy source, a laser/light source, another type of energy source or generator, and the like, and combinations thereof. In other embodiments, energy generation device 42 is substituted with or use in addition to a source of fluid, such a cryogenic

fluid or other fluid that modulates temperature. Likewise, the delivery module (e.g., delivery module 40), as used herein, can also be a cryogenic device or other device that is configured for thermal modulation.

**[0050]** With continued reference to the schematic of FIG. 1, the energy delivery module 40 can include one or more input/output devices or components 44, such as, for example, a touchscreen device, a screen or other display, a controller (e.g., button, knob, switch, dial, etc.), keypad, mouse, joystick, trackpad, or other input device and/or the like. Such devices can permit a physician or other user to enter information into and/or receive information from the system 10. In some embodiments, the output device 44 can include a touchscreen or other display that provides tissue temperature information, contact information, other measurement information and/or other data or indicators that can be useful for regulating a particular treatment procedure.

**[0051]** According to some embodiments, the energy delivery module 40 includes a processor 46 (e.g., a processing or control unit) that is configured to regulate one or more aspects of the treatment system 10. The module 40 can also comprise a memory unit or other storage device 48 (e.g., computer readable medium) that can be used to store operational parameters and/or other data related to the operation of the system 10. In some embodiments, the processor 46 is configured to automatically regulate the delivery of energy from the energy generation device 42 to the energy delivery member 30 of the medical instrument 20 based on one or more operational schemes. For example, energy provided to the energy delivery member 30 (and thus, the amount of heat transferred to or from the targeted tissue) can be regulated based on, among other things, the detected temperature of the tissue being treated.

**[0052]** According to some embodiments, the energy delivery system 10 can include one or more temperature detection devices, such as, for example, reference temperature devices (e.g., thermocouples, thermistors, etc.) and/or the like. For example, in some embodiments, the device further comprises a one or more temperature sensors or other temperature-measuring devices to help determine a peak (e.g., high or peak, low or trough, etc.) temperature of tissue being treated. In some embodiments, the temperature sensors (e.g., thermocouples) located at, along and/or near the ablation member (e.g., RF electrode) can help with the determination of whether contact is being made between the ablation member and targeted tissue (and/or to what degree such contact is being made). In some embodiments, such peak temperature is determined without the use of radiometry.

**[0053]** With reference to FIG. 1, the energy delivery system 10 comprises (or is in configured to be placed in fluid communication with) an irrigation fluid system 70. In some embodiments, as schematically illustrated in FIG. 1, such a fluid system 70 is at least partially separate from the energy delivery module 40 and/or other components of the system 10. However, in other embodiments, the irrigation fluid system 70 is incorporated, at least partially, into the energy delivery module 40. The irrigation fluid system 70 can include one or more pumps or other fluid transfer devices that are configured to selectively move fluid through one or more lumens or other passages of the catheter 20. Such fluid can be used to selectively cool (e.g., transfer heat away from) the energy delivery member 30 during use.

**[0054]** FIG. 2 illustrates one embodiment of a distal end of a medical instrument (e.g., catheter) 20. As shown, the

catheter 20 can include a high-resolution tip design, such that there are two adjacent electrodes or two adjacent electrode portions 30A, 30B separated by a gap G. According to some embodiments, as depicted in the configuration of FIG. 2, the relative length of the different electrodes or electrode portions 30A, 30B can vary. For example, the length of the proximal electrode 30B can be between 1 to 20 times (e.g., 1-2, 2-3, 3-4, 4-5, 5-6, 6-7, 7-8, 8-9, 9-10, 10-11, 11-12, 12-13, 13-14, 14-15, 15-16, 16-17, 17-18, 18-19, 19-20, values between the foregoing ranges, etc.) the length of the distal electrode 30A, as desired or required. In other embodiments, the length of the proximal electrode 30B can be greater than 20 times (e.g., 20-25, 25-30, more than 30 times, etc.) the length of the distal electrode 30A. In yet other embodiments, the lengths of the distal and proximal electrodes 30A, 30B are about equal. In some embodiments, the distal electrode 30A is longer than the proximal electrode 30B (e.g., by 1 to 20 times, such as, for example, 1-2, 2-3, 3-4, 4-5, 5-6, 6-7, 7-8, 8-9, 9-10, 10-11, 11-12, 12-13, 13-14, 14-15, 15-16, 16-17, 17-18, 18-19, 19-20, values between the foregoing ranges, etc.).

**[0055]** In some embodiments, the distal electrode or electrode portion 30A is 0.5 mm long. In other embodiments, the distal electrode or electrode portion 30A is between 0.1 mm and 1 mm long (e.g., 0.1-0.2, 0.2-0.3, 0.3-0.4, 0.4-0.5, 0.5-0.6, 0.6-0.7, 0.8-0.9, 0.9-1 mm, values between the foregoing ranges, etc.). In other embodiments, the distal electrode or electrode portion 30A is greater than 1 mm in length, as desired or required. In some embodiments, the proximal electrode or electrode portion 30B is 2 to 4 mm long (e.g., 2-2.5, 2.5-3, 3-3.5, 3.5-4 mm, lengths between the foregoing, etc.). However, in other embodiments, the proximal electrode portion 30B is greater than 4 mm (e.g., 4-5, 5-6, 6-7, 7-8, 8-9, 9-10 mm, greater than 10 mm, etc.) or smaller than 1 mm (e.g., 0.1-0.5, 0.5-1, 1-1.5, 1.5-2 mm, lengths between the foregoing ranges, etc.), as desired or required. In embodiments where the high-resolution electrodes are located on catheter shafts, the length of the electrodes can be 1 to 5 mm (e.g., 1-2, 2-3, 3-4, 4-5 mm, lengths between the foregoing, etc.). However, in other embodiments, the electrodes can be longer than 5 mm (e.g., 5-6, 6-7, 7-8, 8-9, 9-10, 10-15, 15-20 mm, lengths between the foregoing, lengths greater than 20 mm, etc.), as desired or required.

**[0056]** As noted above, the use of a high-resolution tip design can permit a user to simultaneously ablate or otherwise thermally treat targeted tissue and map (e.g., using high-resolution mapping) in a single configuration. Thus, such systems can advantageously permit precise high-resolution mapping (e.g., to confirm that a desired level of treatment occurred) during a procedure. In some embodiments, the high-resolution tip design that includes two electrodes or electrode portions 30A, 30B can be used to record a high-resolution bipolar electrogram. For such purposes, the two electrodes or electrode portions can be connected to the inputs of an EP recorder. In some embodiments, a relatively small separation distance (e.g., gap G) between the electrodes or electrode portions 30A, 30B enables high-resolution mapping.

**[0057]** In some embodiments, a medical instrument (e.g., a catheter) 20 can include three or more electrodes or electrode portions (e.g., separated by gaps), as desired or required. Additional details regarding such arrangements are provided below. According to some embodiments, regard-

less of how many electrodes or electrode portions are positioned along a catheter tip, the electrodes or electrode portions 30A, 30B are radiofrequency electrodes and comprise one or more metals, such as, for example, stainless steel, platinum, platinum-iridium, gold, gold-plated alloys and/or the like.

**[0058]** According to some embodiments, as illustrated in FIG. 2, the electrodes or electrode portions 30A, 30B are spaced apart from each other (e.g., longitudinally or axially) using a gap (e.g., an electrically insulating gap). In some embodiments, the length of the gap G (or the separation distance between adjacent electrodes or electrode portions) is 0.5 mm. In other embodiments, the gap G or separation distance is greater or smaller than 0.5 mm, such as, for example, 0.1-1 mm (e.g., 0.1-0.2, 0.2-0.3, 0.3-0.4, 0.4-0.5, 0.5-0.6, 0.6-0.7, 0.7-0.8, 0.8-0.9, 0.9-1.0 mm, values between the foregoing ranges, less than 0.1 mm, greater than 1 mm, etc.), as desired or required.

**[0059]** According to some embodiments, a separator 34 is positioned within the gap G, between the adjacent electrodes or electrode portions 30A, 30B, as depicted in FIG. 2. The separator can comprise one or more electrically insulating materials, such as, for example, Teflon, polyetheretherketone (PEEK), polyetherimide resins (e.g., ULTEM™), ceramic materials, polyimide and the like.

**[0060]** As noted above with respect to the gap G separating the adjacent electrodes or electrode portions, the insulating separator 34 can be 0.5 mm long. In other embodiments, the length of the separator 34 can be greater or smaller than 0.5 mm (e.g., 0.1-0.2, 0.2-0.3, 0.3-0.4, 0.4-0.5, 0.5-0.6, 0.6-0.7, 0.7-0.8, 0.8-0.9, 0.9-1.0 mm, values between the foregoing ranges, less than 0.1 mm, greater than 1 mm, etc.), as desired or required.

**[0061]** According to some embodiments, as discussed in greater detail herein, to ablate or otherwise heat or treat targeted tissue of a subject successfully with the high-resolution tip electrode design, such as the one depicted in FIG. 2, the two electrodes or electrode portions 30A, 30B are electrically coupled to each other at the RF frequency. Thus, the two electrodes or electrode portions can advantageously function as a single longer electrode at the RF frequency.

**[0062]** FIGS. 3 and 4 illustrate different embodiments of catheter systems 100, 200 that incorporate a high-resolution tip design. For example, in FIG. 3, the electrode (e.g., radiofrequency electrode) along the distal end of the electrode comprises a first or distal electrode or electrode portion 110 and a second or proximal electrode or electrode portion 114. As shown and discussed in greater detail herein with reference to other configurations, the high-resolution tip design 100 includes a gap G between the first and second electrodes or electrode portions 110, 114. In some configurations, the second or proximal electrode or electrode portion 114 is generally longer than the first or distal electrode or electrode portion 110. For instance, the length of the proximal electrode 114 can be between 1 to 20 times (e.g., 1-2, 2-3, 3-4, 4-5, 5-6, 6-7, 7-8, 8-9, 9-10, 10-11, 11-12, 12-13, 13-14, 14-15, 15-16, 16-17, 17-18, 18-19, 19-20, values between the foregoing ranges, etc.) the length of the distal electrode 110, as desired or required. In other embodiments, the length of the proximal electrode can be greater than 20 times (e.g., 20-25, 25-30, more than 30 times, etc.) the length of the distal electrode. In yet other embodiments, the lengths of the distal and proximal electrodes are about

the same. However, in some embodiments, the distal electrode 110 is longer than the proximal electrode 114 (e.g., by 1 to 20 times, such as, for example, 1-2, 2-3, 3-4, 4-5, 5-6, 6-7, 7-8, 8-9, 9-10, 10-11, 11-12, 12-13, 13-14, 14-15, 15-16, 16-17, 17-18, 18-19, 19-20, values between the foregoing ranges, etc.).

**[0063]** As shown in FIG. 3 and noted above, regardless of their exact design, relative length diameter, orientation and/or other characteristics, the electrodes or electrode portions 110, 114 can be separated by a gap G. The gap G can comprise a relatively small electrically insulating gap or space. In some embodiments, an electrically insulating separator 118 can be snugly positioned between the first and second electrodes or electrode portions 110, 114. In certain embodiments, the separator 118 can have a length of about 0.5 mm. In other embodiments, however, the length of the separator 118 can be greater or smaller than 0.5 mm (e.g., 0.1-0.2, 0.2-0.3, 0.3-0.4, 0.4-0.5, 0.5-0.6, 0.6-0.7, 0.7-0.8, 0.8-0.9, 0.9-1.0 mm, values between the foregoing ranges, less than 0.1 mm, greater than 1 mm, etc.), as desired or required. The separator can include one or more electrically insulating materials (e.g., materials that have an electrical conductivity less than about 1000 or less (e.g., 500-600, 600-700, 700-800, 800-900, 900-1000, 1000-1100, 1100-1200, 1200-1300, 1300-1400, 1400-1500, values between the foregoing, less than 500, greater than 1500, etc.) than the electrical conductivity of metals or alloys). The separator can comprise one or more electrically insulating materials, such as, for example, Teflon, polyetheretherketone (PEEK), polyoxymethylene, acetal resins or polymers and the like.

**[0064]** As shown in FIG. 3, the separator 118 can be cylindrical in shape and can have the identical or similar diameter and configuration as the adjacent electrodes or electrode portions 110, 114. Thus, in some embodiments, the outer surface formed by the electrodes or electrode portions 110, 114 and the separator 118 can be generally uniform or smooth. However, in other embodiments, the shape, size (e.g., diameter) and/or other characteristics of the separator 118 can be different than one or more of the adjacent electrodes or electrode portions 110, 114, as desired or required for a particular application or use.

**[0065]** FIG. 4 illustrates an embodiment of a system 200 having three or more electrodes or electrode portions 210, 212, 214 separated by corresponding gaps G1, G2. The use of such additional gaps, and thus, additional electrodes or electrode portions 210, 212, 214 that are physically separated (e.g., by gaps) yet in close proximity to each other, can provide additional benefits to the high-resolution mapping capabilities of the system. For example, the use of two (or more) gaps can provide more accurate high-resolution mapping data related to the tissue being treated. Such multiple gaps can provide information about the directionality of cardiac signal propagation. In addition, high-resolution mapping with high-resolution electrode portions involving multiple gaps can provide a more extended view of lesion progression during the ablation process and higher confidence that viable tissue strands are not left behind within the targeted therapeutic volume. In some embodiments, high-resolution electrodes with multiple gaps can optimize the ratio of mapped tissue surface to ablated tissue surface. Preferably, such ratio is in the range of 0.2 to 0.8 (e.g., 0.2-0.3, 0.3-0.4, 0.4-0.5, 0.5-0.6, 0.6-0.7, 0.7-0.8, ratios between the foregoing, etc.). Although FIG. 4 illustrates an embodiment having a total of three electrodes or electrode

portions **210**, **212**, **214** (and thus, two gaps **G1**, **G2**), a system can be designed or otherwise modified to comprise additional electrodes or electrode portions, and thus, additional gaps. For example, in some embodiments, an ablation or other treatment system can include 4 or more (e.g., 5, 6, 7, 8, more than 8, etc.) electrodes or electrode portions (and thus, 3 or more gaps, e.g., 3, 4, 5, 6, 7 gaps, more than 7 gaps, etc.), as desired or required. In such configurations, a gap (and/or an electrical separator) can be positioned between adjacent electrodes or electrode portions, in accordance with the embodiments illustrated in FIGS. **2** to **4**.

**[0066]** As depicted in FIGS. **3** and **4**, an irrigation tube **120**, **220** can be routed within an interior of the catheter (not shown for clarity). In some embodiments, the irrigation tube **120**, **220** can extend from a proximal portion of the catheter (e.g., where it can be placed in fluid communication with a fluid pump) to the distal end of the system. For example, in some arrangements, as illustrated in the side views of FIGS. **3** and **4**, the irrigation tube **120**, **220** extends and is in fluid communication with one or more fluid ports **211** that extend radially outwardly through the distal electrode **110**, **210**. Thus, in some embodiments, the treatment system comprises an open irrigation design, wherein saline and/or other fluid is selectively delivered through the catheter (e.g., within the fluid tube **120**, **220**) and radially outwardly through one or more outlet ports **111**, **211** of an electrode **110**, **210**. The delivery of such saline or other fluid can help remove heat away from the electrodes and/or the tissue being treated. In some embodiments, such an open irrigation system can help prevent or reduce the likelihood of overheating of targeted tissue, especially along the tissue that is contacted by the electrodes. An open irrigation design is also incorporated in the system that is schematically illustrated in FIG. **2**. For instance, as depicted in FIG. **2**, the distal electrode or electrode portion **34** can include a plurality of outlet ports **36** through which saline or other irrigation fluid can exit.

**[0067]** According to some embodiments, a catheter can include a high-resolution-tip electrode design that includes one or more gaps in the circumferential direction (e.g., radially), either in addition to or in lieu of gaps in the longitudinal direction. One embodiment of a system **300** comprising one or more electrodes **310A**, **310B** is illustrated in FIG. **5**. As shown, in arrangements where two or more electrodes are included, the electrodes **310A**, **310B** can be longitudinally or axially offset from each other. For example, in some embodiments, the electrodes **310A**, **310B** are located along or near the distal end of a catheter. In some embodiments, the electrodes **310A**, **310B** are located along an exterior portion of a catheter or other medical instrument. However, in other configurations, one or more of the electrodes can be positioned along a different portion of the catheter or other medical instrument (e.g., along at least an interior portion of a catheter), as desired or required.

**[0068]** With continued reference to FIG. **5**, each electrode **310A**, **310B** can comprise two or more sections **320A**, **322A** and/or **320B**, **320B**. As shown, in some embodiments, the each section **320A**, **322A** and/or **320B**, **320B** can extend half-way around (e.g., 180 degrees) the diameter of the catheter. However, in other embodiments, the circumferential extent of each section can be less than 180 degrees. For example, each section can extend between 0 and 180 degrees (e.g., 15, 30, 45, 60, 75, 90, 105, 120 degrees, degrees between the foregoing, etc.) around the circumference of the catheter along which it is mounted. Thus, in some embodi-

ments, an electrode can include 2, 3, 4, 5, 6 or more circumferential sections, as desired or required.

**[0069]** Regardless of how the circumferential electrode sections are designed and oriented, electrically insulating gaps **G** can be provided between adjacent sections to facilitate the ability to use the electrode to conduct high-resolution mapping, in accordance with the various embodiments disclosed herein. Further, as illustrated in the embodiment of FIG. **5**, two or more (e.g., 3, 4, 5, more than 5, etc.) electrodes **310A**, **310B** having two or more circumferential or radial sections can be included in a particular system **300**, as desired or required.

**[0070]** In alternative embodiments, the various embodiments of a high-resolution tip design disclosed herein, or variations thereof, can be used with a non-irrigated system or a closed-irrigation system (e.g., one in which saline and/or other fluid is circulated through or within one or more electrodes to selectively remove heat therefrom). Thus, in some arrangements, a catheter can include two or more irrigation tubes or conduits. For example, one tube or other conduit can be used to deliver fluid toward or near the electrodes, while a second tube or other conduit can be used to return the fluid in the reverse direction through the catheter.

**[0071]** According to some embodiments, a high-resolution tip electrode is designed to balance the current load between the various electrodes or electrode portions. For example, if a treatment system is not carefully configured, the electrical load may be delivered predominantly to one or more of the electrodes or electrode portions of the high-resolution tip system (e.g., the shorter or smaller distal electrode or electrode portion). This can lead to undesirable uneven heating of the electrode, and thus, uneven heating (e.g., ablation) of the adjacent tissue of the subject. Thus, in some embodiments, one or more load balancing configurations can be used to help ensure that the heating along the various electrodes or electrode portions of the system will be generally balanced. As a result, the high-resolution tip design can advantageously function more like a longer, single electrode, as opposed to two or more electrodes that receive an unequal electrical load (and thus, deliver an unequal amount of heat or level of treatment to the subject's targeted tissue).

**[0072]** One embodiment of a configuration that can be used to balance the electrical current load delivered to each of the electrodes or electrode portions in a high-resolution tip design is schematically illustrated in FIG. **6**. As shown, one of the electrodes (e.g., the distal electrode) **30A** can be electrically coupled to an energy delivery module **40** (e.g., a RF generator). As discussed herein, the module **40** can comprise one or more components or features, such as, for example, an energy generation device that is configured to selectively energize and/or otherwise activate the energy members (e.g., RF electrodes), one or more input/output devices or components, a processor (e.g., a processing or control unit) that is configured to regulate one or more aspects of the treatment system, a memory and/or the like. Further, such a module can be configured to be operated manually or automatically, as desired or required.

**[0073]** In the embodiment that is schematically depicted in FIG. **6**, the distal electrode **30A** is energized using one or more conductors **82** (e.g., wires, cables, etc.). For example, in some arrangements, the exterior of the irrigation tube **38** comprises and/or is otherwise coated with one or more

electrically conductive materials (e.g., copper, other metal, etc.). Thus, as shown in FIG. 6, the conductor 82 can be placed in contact with such a conductive surface or portion of the tube 38 to electrically couple the electrode or electrode portion 30A to an energy delivery module. However, one or more other devices and/or methods of placing the electrode or electrode portion 30A in electrical communication with an energy delivery module can be used. For example, one or more wires, cables and/or other conductors can directly or indirectly couple to the electrodes, without the use of the irrigation tube.

[0074] With continued reference to FIG. 6, the first or distal electrode or electrode portion 30A can be electrically coupled to the second or proximal electrode or electrode portion 30B using one more band-pass filtering elements 84, such as a capacitor, a filter circuit, etc. For instance, in some embodiments, the band-pass filtering element 84 comprises a capacitor that electrically couples the two electrodes or electrode portions 30A, 30B when radiofrequency current is applied to the system. In one embodiment, the capacitor 84 comprises a 100 nF capacitor that introduces a series impedance lower than about  $3\Omega$  at 500 kHz, which, according to some arrangements, is a target frequency for RF ablation. However, in other embodiments, the capacitance of the capacitor(s) or other band-pass filtering elements 84 that are incorporated into the system can be greater or less than 100 nF, for example, 5 nF to 300 nF, according to the operating RF frequency, as desired or required. In some embodiments, the capacitance of the filtering element 84 is selected based on a target impedance at a particular frequency or frequency range. For example, in some embodiments, the system can be operated at a frequency of 200 kHz to 10 MHz (e.g., 200-300, 300-400, 400-500, 500-600, 600-700, 700-800, 800-900, 900-1000 kHz, up to 10 MHz or higher frequencies between the foregoing ranges, etc.). Thus, the capacitor that couples adjacent electrodes or electrode portions to each other can be selected based on the target impedance for a particular frequency. For example, a 100 nF capacitor provides about  $3\Omega$  of coupling impedance at an operating ablation frequency of 500 kHz.

[0075] In some embodiments, a series impedance of  $3\Omega$  across the electrodes or electrode portions 30A, 30B is sufficiently low when compared to the impedance of the conductor 82 (e.g., wire, cable, etc.), which can be about  $5\text{-}10\Omega$ , and the impedance of tissue, which can be about  $100\Omega$ , such that the resulting tissue heating profile is not negatively impacted when the system is in use. Thus, in some embodiments, a filtering element is selected so that the series impedance across the electrodes or electrode portions is lower than the impedance of the conductor that supplies RF energy to the electrodes. For example, in some embodiments, the insertion impedance of the filtering element is 50% of the conductor 82 impedance, or lower, or 10% of the equivalent tissue impedance, or lower.

[0076] In some embodiments, a filtering element (e.g., capacitor a filter circuit such as the one described herein) can be located at a variety of locations of the device or accompanying system. For example, in some embodiments, the filtering element is located on or within a catheter (e.g., near the distal end of the catheter, adjacent the electrode, etc.). In other embodiments, however, the filtering element is separate of the catheter. For instance, the filtering element can be positioned within or along a handle to which the catheter is secured, within the generator or other energy delivery mod-

ule, within a separate processor or other computing device or component and/or the like).

[0077] Similarly, with reference to the schematic of FIG. 7, a filtering element 384 can be included in an electrode 310 comprising circumferentially-arranged portions 320, 322. In FIG. 7, the filtering element 384 permits the entire electrode 310 to be energized within RF frequency range (e.g., when the electrode is activated to ablate). One or more RF wires or other conductors 344 can be used to deliver power to the electrode from a generator or source. In addition, separate conductors 340 can be used to electrically couple the electrode 310 for mapping purposes.

[0078] In embodiments where the high-resolution-tip design (e.g., FIG. 4) comprises three or more electrodes or electrode portions, additional filtering elements (e.g., capacitors) can be used to electrically couple the electrodes or electrode portions to each other. Such capacitors or other filtering elements can be selected to create a generally uniform heating profile along the entire length of the high-resolution tip electrode. As noted in greater detail herein, for any of the embodiments disclosed herein or variations thereof, the filtering element can include something other than a capacitor. For example, in some arrangements, the filtering element comprises a LC circuit (e.g., a resonant circuit, a tank circuit, a tuned circuit, etc.). Such embodiments can be configured to permit simultaneous application of RF energy and measurement of EGM recordings.

[0079] As discussed above, the relatively small gap G between the adjacent electrodes or electrode portions 30A, 30B can be used to facilitate high-resolution mapping of the targeted tissue. For example, with continued reference to the schematic of FIG. 6, the separate electrodes or electrode portions 30A, 30B can be used to generate an electrogram that accurately reflects the localized electrical potential of the tissue being treated. Thus, a physician or other practitioner using the treatment system can more accurately detect the impact of the energy delivery to the targeted tissue before, during and/or after a procedure. For example, the more accurate electrogram data that result from such configurations can enable the physician to detect any gaps or portions of the targeted anatomical region that was not properly ablated or otherwise treated. Specifically, the use of a high-resolution tip design can enable a cardiac electrophysiologist to more accurately evaluate the morphology of resulting electrograms, their amplitude and width and/or to determine pacing thresholds. In some embodiments, morphology, amplitude and pacing threshold are accepted and reliable EP markers that provide useful information about the outcome of an ablation or other heat treatment procedure.

[0080] According to some arrangements, the high-resolution-tip electrode embodiments disclosed herein are configured to provide localized high-resolution electrogram. For example, the electrogram that is obtained using a high-resolution-tip electrode, in accordance with embodiments disclosed herein, can provide electrogram data (e.g., graphical output) 400a, 400b as illustrated in FIG. 8. As depicted in FIG. 8, the localized electrograms 400a, 400b generated using the high-resolution-tip electrode embodiments disclosed herein include an amplitude A1, A2.

[0081] With continued reference to FIG. 8, the amplitude of the electrograms 400a, 400b obtained using high-resolution-tip electrode systems can be used to determine whether targeted tissue adjacent the high-resolution-tip electrode has

been adequately ablated or otherwise treated. For example, according to some embodiments, the amplitude **A1** of an electrogram **400a** in untreated tissue (e.g., tissue that has not been ablated or otherwise heated) is greater than the amplitude **A2** of an electrogram **400b** that has already been ablated or otherwise treated. In some embodiments, therefore, the amplitude of the electrogram can be measured to determine whether tissue has been treated. For example, the electrogram amplitude **A1** of untreated tissue in a subject can be recorded and used as a baseline. Future electrogram amplitude measurements can be obtained and compared against such a baseline amplitude in an effort to determine whether tissue has been ablated or otherwise treated to an adequate or desired degree.

**[0082]** In some embodiments, a comparison is made between such a baseline amplitude (**A1**) relative to an electrogram amplitude (**A2**) at a tissue location being tested or evaluated. A ratio of **A1** to **A2** can be used to provide a quantitative measure for assessing the likelihood that ablation has been completed. In some arrangements, if the ratio (i.e.,  $A1/A2$ ) is above a certain minimum threshold, then the user can be informed that the tissue where the **A2** amplitude was obtained has been properly ablated. For example, in some embodiments, adequate ablation or treatment can be confirmed when the  $A1/A2$  ratio is greater than 1.5 (e.g., 1.5-1.6, 1.6-1.7, 1.7-1.8, 1.8-1.9, 1.9-2.0, 2.0-2.5, 2.5-3.0, values between the foregoing, greater than 3, etc.). However, in other embodiments, confirmation of ablation can be obtained when the ratio of  $A1/A2$  is less than 1.5 (e.g., 1-1.1, 1.1-1.2, 1.2-1.3, 1.3-1.4, 1.4-1.5, values between the foregoing, etc.).

**[0083]** According to some embodiments, an ablation system is configured to operatively couple to a pacemaker or related system that is configured to selectively pace or increase the heart rate of a subject. As discussed in greater detail herein, the use of such pacing can be used to confirm whether targeted tissue (e.g., cardiac tissue) has been properly ablated. Accordingly, such a system and related method can provide the user with information for assessing the success of a treatment procedure. For example, data provided by the system can be used to determine if the targeted tissue has been properly ablated. Thus, the various systems, devices and methods disclosed herein can be used to ensure that a desired or required level of treatment to targeted tissue has been accomplished. The confirmation and other feedback provided by the various systems, devices and methods disclosed herein can be used in addition to or in lieu of any other protocols for confirming successful treatment of targeted tissue.

**[0084]** According to some embodiments, an energy delivery module (e.g., a radiofrequency generator or other energy delivery generator) of an ablation system can be configured to be coupled to a pacemaker device or system. In some embodiments, such a pacemaker comprises a separate device or system that is separate and distinct from the energy delivery module and/or other components of the ablation system. However, in other configurations, the pacemaker device or system can be integrated within the energy delivery module and/or any other component of the system.

**[0085]** Regardless of whether the pacemaker device or system is integrated within or separate from the energy delivery module (e.g., radiofrequency generator) and/or any other component of an ablation system, such a pacemaker device or system can be configured to selectively pace

cardiac tissue or increase a heart rate of a subject being treated. According to some embodiments, such pacing or an increase in heart rate is performed for purposes of confirming successful ablation of targeted tissue (e.g., atrial, ventricular and/or other cardiac tissue), as discussed in greater detail herein. However, the use of pacing can be performed for one or more other purposes as well, either in addition to or in lieu of confirmation of ablation, as desired or required.

**[0086]** In some embodiments, the heart of the subject is selectively paced (e.g., the heart rate of the subject is increased) to a desired level by delivering a pacing signal to the heart via one or more electrodes. For example, as illustrated schematically in FIG. 9, a system **2000** can comprise an energy delivery module (e.g., a radiofrequency generator or other generator) **2240** that is configured to couple to a catheter or other medical instrument **2220**. As shown in the depicted arrangement and discussed in greater detail herein with reference to one or more embodiments, the catheter or other medical instrument **2220** can comprise one or more high-resolution electrodes or electrode portions **2222**, **2224** located along the distal end of the catheter or other medical instrument **2220**. In some embodiments, such high-resolution electrodes or electrode portions **2222**, **2224** are electrically coupled to each other using one or more filtering elements (e.g., capacitors, other filtering elements, etc.) that permit the electrodes or electrode portions **2222**, **2224** to selectively deliver ablative (e.g., radiofrequency) energy to targeted tissue of a subject while permitting the electrodes or electrode portions to obtain high-resolution mapping data of adjacent tissue (e.g., when ablative energy is not being provided to the electrodes or electrode portions), as discussed herein. For example, and without limitation, the filtering element positioned between the electrodes or electrode portions **2222**, **2224** in FIG. 9 comprises a capacitor.

**[0087]** With continued reference to FIG. 9, the system **2000** can further comprise a catheter cable **2250** that is used to physically and/or operatively couple the catheter or other medical instrument **2220** to the energy delivery module (e.g., RF generator) **2240**. In some embodiments, such a cable or other connector **2250** can be physically incorporated into the design of the catheter or other medical instrument **2220**. However, in other embodiments, the catheter cable **2250** can be separate and distinct from the catheter or other medical instrument **2220**, as desired or required.

**[0088]** As shown in FIG. 9, the energy delivery module (e.g., a RF generator) can be configured to couple to a pacemaker device or system **2400**. As noted herein, the pacemaker device or system can be incorporated into the energy delivery module **2240** or can be separate from it. Thus, in some embodiments, the RF generator or any other energy delivery module **2240** can include one or more ports and/or other couplings that are configured to receive, either directly or indirectly, a connection from a pacemaker device or system **2400** (e.g., an off-the-shelf or other third-party pacemaker device or system). In the embodiment schematically illustrated in FIG. 9, a pacemaker device or system **2400** is configured to indirectly couple to the energy delivery module **2240**, as the pacemaker device or system **2400** connects or otherwise attaches or couples, via a pacemaker cable **2410**, to a different component or device of the system **2000** (e.g., an EP recording system **2310**, such as, a recording system provided by a third party, a recorder cable **2300** that operatively couples to the energy delivery module and/or EP recorder, etc.). However, in other arrangements,

an energy delivery module (e.g., a RF generator) can be designed and otherwise configured to directly receive a pacemaker cable 2410 and/or other connection from a pacemaker device or system 2400, as desired or required. Any ports and/or other connection sites included in the RF generator (or other energy delivery module) 2240 and/or any other component of the system 2000 that is configured to receive a pacemaker cable 2410 or other connection from a pacemaker device or system 2400 can be standard or non-standard.

[0089] In some embodiments, once operatively coupled to an ablation/monitoring system 2000, a pacemaker device or system 2400 can be used to provide a pacing current to the catheter or other medical instrument 2220 in order to selectively increase the heart rate of the subject's heart. For example, in some embodiments, the heart rate of a subject can be increased from a baseline heart rate to 100-200 beats per minute, bpm, (e.g., 100-105, 105-110, 110-115, 115-120, 120-125, 125-130, 130-135, 135-140, 140-145, 145-150, 150-160, 160-170, 170-180, 180-190, 190-200 bpm, 120-150 bpm, frequencies between the foregoing, etc.) by delivering a pacing signal to the catheter.

[0090] Further, according to some embodiments, the pacing current generated by the pacemaker device or system 2400 is directed to and routed, at least partially, through the energy delivery module (e.g., RF generator) 2240. In some embodiments, the energy delivery module 2240 comprises a filter section 2246 through which the pacing current passes. According to some configurations, the filter section 2246 of the energy delivery module 2240 comprises low insertion impedance EGM filters that facilitate the delivery of the pacing current to the catheter or other medical instrument 2220 coupled to the energy delivery module 2240. Such filters can permit the system 2000 to deliver energy (e.g., radiofrequency energy, other ablative energy, etc.) to the electrode(s) of the catheter 2220 while simultaneously providing a desired pacing current to such electrode(s).

[0091] With continued reference to the schematic of FIG. 9, the energy delivery module (e.g., RF generator) 2240 can further include an energy delivery portion 2244. Accordingly, RF and/or other energy generated by the energy delivery module 2240 can be delivered to a catheter or other medical instrument 2220 to ablate or otherwise provide heat treatment to targeted tissue of a subject P. In some embodiments, the catheter or other medical instrument 2220 is coupled to the energy delivery module (e.g., RF generator) 2240 using a catheter cable 2250.

[0092] As discussed with reference to other embodiments herein, the catheter or other medical instrument 2220 that operatively couples to the energy delivery module 2240 can include a high-resolution electrode design. For example, in some embodiments, the catheter comprises an electrode that is configured to obtain high-resolution mapping data (e.g., when ablative energy is not being delivered to the electrode), in accordance with the various embodiments disclosed herein, or variations thereof. For example, a filtering element or other feature can advantageously permit the electrode along the distal end of the catheter or other medical instrument 2220 to obtain high resolution mapping data before and/or after ablative energy (e.g., radiofrequency energy) has been delivered to the catheter or other medical instrument 2220. In some embodiments, the design of such a high-resolution electrode assembly can permit a user to

obtain and use accurate mapping data associated with the specific location of the electrode.

[0093] As schematically illustrated in FIG. 9, the catheter or other medical instrument 2220 of the system 2000 can comprise a high-resolution electrode assembly (e.g., first and second electrodes or electrode portions 2222, 2224 located along the distal end of the catheter or medical instrument). Further, in some embodiments, the catheter or other medical instrument 2220 can comprise one or more (e.g., 2, 3, more than 3, etc.) additional mapping electrodes (e.g., standard ring electrodes) located along or near the high-resolution electrodes or electrode portions. For example, in some embodiments, a catheter 2220 can include two ring electrodes 2228 that are located proximal to the high-resolution electrode(s) or electrode portion(s) and that are configured to obtain mapping data from surrounding tissue of the subject.

[0094] In some embodiments, any of the cardiac pacing concepts disclosed herein (e.g., the ability to provide pacing currents to a catheter or other medical instrument, the ability to pace or increase the heart rate of a subject prior to or during a cardiac treatment procedure, etc.) can be used with catheters or other medical instruments that do not include high-resolution mapping electrodes or related features. Thus, the pacing concepts (e.g., and the related confirmation of ablation of targeted tissue) can be incorporated into any energy delivery and/or mapping technologies, regardless of whether they are specifically described or otherwise disclosed herein.

[0095] According to some embodiments, pacing currents can be provided to the electrode or other energy delivery device of a catheter (or other medical instrument). In some arrangements, the pacing current that is provided to the electrode or other energy delivery device is greater than the pre-ablation pacing threshold level, but lower than the post-ablation pacing threshold level. For example, once paced (e.g., using the current or signal provided by the pacemaker device or system 2400), the subject's heart will be paced (e.g., the subject's heart rate will increase to an elevated heart rate frequency or level). As discussed in greater detail herein, for instance, the pacemaker signal can increase the subject's heart rate to 100-150 beats per minute (bpm), e.g., 100-105, 105-110, 110-115, 115-120, 120-125, 125-130, 130-135, 135-140, 140-145, 145-150 bpm, value between the foregoing ranges, etc.). In other embodiments, the pacing can increase a subject's heart rate to levels exceeding 150 bpm (e.g., 150-160, 160-170, 170-180 bpm, values between the foregoing ranges, values greater than 180 bpm, etc.) or less than 100 bpm (e.g., 70-75, 75-80, 80-85, 85-90, 90-95, 95-100 bpm, values between the foregoing ranges, values less than 70 bpm, etc.), as desired or required.

[0096] According to some embodiments, as indicated above, the pacing current provided by the pacemaker device or system 2400 coupled to (or integrated with) the energy delivery module (e.g., the RF generator) 2240 will exceed a pre-ablation pacing threshold. In other words, the pacing current will be configured to stimulate the subject's heart to a desired elevated rate or level and will also be configured to surpass the pacing threshold at which the targeted tissue of the subject will be ablated or otherwise heat-treated to a desired level.

[0097] In some embodiments, the pacing current provided by the pacemaker device or system 2400 is greater than 15 milliamperes (mA). For example, the pacing current provided

by the pacemaker device or system is 15-20 milliamps (mA), e.g., 15-16, 16-17, 17-18, 18-19, 19-20 mA, currents between the foregoing ranges, etc. In other embodiments, the pacing current provided by the pacemaker device or system is less than 15 mA (e.g., 10-11, 11-12, 12-13, 13-14, 14-15 mA, currents between the foregoing ranges, etc.) or greater than 20 mA, (e.g., 20-21, 21-22, 22-23, 23-24, 24-25, 25-30 mA, currents between the foregoing ranges, currents greater than 30 mA, etc.), as desired or required. In some embodiments, the pacing current provided by the pacemaker device or system is 5 to 20 mA (e.g., 10-15 mA).

**[0098]** Regardless of the exact pacing current provided to the electrode(s) or electrode portion(s) of the catheter or other medical instrument by the pacemaker device or system, the heart rate of the subject being treated will increase above the subject's baseline (e.g., normal) heart rate. In some embodiments, the formation of a lesion or the completion of heat treatment of the targeted tissue will cause the pacing threshold to increase considerably, from pre-ablation levels (e.g. 1 to 5 mA) to post-ablation levels (e.g. 15 to 20 mA, or greater). By way of example, and without limitation, in some embodiments, it is possible that the pre-ablation pacing threshold is approximately 1 mA and the post-ablation pacing threshold is approximately 20 mA. In such circumstances, application of pacing currents of 10 mA would produce "heart capture," meaning an increase of the heart rate to the rate programmed on pacemaker device or system **2400**. With successful ablation treatment, as the pacing threshold increases, the user will observe the cessation of pacing signals being propagated through such a lesion or treated tissue, as the post-ablation pacing threshold exceeds the pacing current amplitude (e.g., in the specific, non-limiting example provided above, 20 mA is greater than 10 mA). As a result, the heart rate of the subject being treated will drop to a level below the elevated heart rate induced by the pacing signal generated by the pacemaker device or system. The loss of such an elevated pacing rate of cardiac tissue is referred to as "loss of capture," providing another form of confirmation to a user that the targeted tissue has been properly treated (e.g., ablated).

**[0099]** In some embodiments, such confirmation of adequate ablation of tissue can help prevent overheating of targeted tissue, as the user is notified in a prompt manner that loss of capture (e.g., or a desired level of tissue ablation) has been attained. As a result, the likelihood of charring or overheating of targeted tissue can be prevented. This can help ensure that undesirable damage to the targeted tissue is avoided and/or that damage to tissue surrounding or adjacent to the targeted tissue is not inadvertently harmed.

**[0100]** The use of high-resolution electrode(s) or electrode portion(s) further enhances the pacing data obtained by the system, in accordance with several embodiments. For example, in some embodiments, the ability of high-resolution electrode(s) or electrode portion(s), in accordance with the various configurations described herein or variations thereof to pace the cardiac tissue located in its immediate vicinity ensures that the devices, systems, methods and techniques disclosed herein have high specificity. As a result, pacing of far-field tissues is avoided. Therefore, the technique advantageously monitors the localized effects of cardiac ablation. As a result, the cardiac data obtained using the system are specific to the anatomical region adjacent the high-resolution electrode, providing a more accurate repre-

sentation of the condition of the targeted tissue. Thus, the likelihood of overheating targeted tissue is advantageously reduced.

**[0101]** According to some embodiments, the pre-ablation pacing threshold is greater than 1 or 2 milliamps (mA). For example, the pre-ablation pacing threshold is 1-5 mA (e.g., 1-1.5, 1.5-2, 2-2.5, 2.5-3, 3-3.5, 3.5-4, 4-4.5, 4.5-5 mA, values between the foregoing ranges, etc.). However, in other embodiments, the pre-ablation pacing threshold is greater than 5 mA (e.g., 5-6, 6-7, 7-8 mA, values between the foregoing ranges, greater than 8 mA, etc.) or less than 1 mA (e.g., 0.1-0.2, 0.2-0.3, 0.3-0.4, 0.4-0.5, 0.5-0.6, 0.6-0.7, 0.7-0.8, 0.8-0.9, 0.9-1 mA, values between the foregoing ranges, values less than 0.1 mA, etc.), as desired or required. In some embodiments, the pre-ablation pacing threshold is 0.1 to 5 mA (e.g., 0.5-2 mA). In addition, in some configurations, the post-ablation pacing threshold is greater than 10 milliamps (mA). For example, the post-ablation pacing threshold is 10-15 mA (e.g., 10-11, 11-12, 12-13, 13-14, 14-15 mA, values between the foregoing ranges, values greater than 15 mA, etc.). However, in other embodiments, the post-ablation pacing threshold is less than 10 mA (e.g., 5-6, 6-7, 7-8, 8-9, 9-10 mA, values between the foregoing ranges, less than 5 mA, etc.), as desired or required. Conversely, in other embodiments, the post-ablation pacing threshold may exceed 20 mA. In some embodiments, the post-ablation pacing threshold exceeds 10 mA or 20 mA.

**[0102]** According to some arrangements, once loss of capture is achieved (e.g., confirmation of ablation or desired/required heat treatment of targeted tissue is received by and/or communicated to a user), the system **2000** can be configured to terminate the delivery of RF (or other energy) from the energy delivery module **2240** (e.g., RF generator) to the catheter or other medical instrument **2220**, either immediately or following a particular time period. In some embodiments, a processor or other control unit of the energy delivery module (and/or any other processor or control unit external to the energy delivery module or system) can be configured to automatically terminate (or alter, e.g., modulate or slow down) the delivery of RF or other energy to the catheter or other medical instrument once loss of capture has been attained.

**[0103]** In other embodiments, however, a processor or other portion of the system (and/or operatively coupled to the system) can be configured to automatically terminate (or alter) a delivery of energy (e.g., RF) to the catheter or other medical instrument after a certain time period after loss of capture has been attained. For example, according to some arrangements, the processor or other control unit of the energy delivery module (e.g., RF generator) and/or any other processor or control unit operatively coupled to the system **2000** can be configured to permit the delivery of energy to the electrode(s) or other energy delivery member of the catheter or other medical instrument for 0.5-5 seconds (e.g., 0.5-1, 1-1.5, 1.5-2, 2-2.5, 2.5-3, 3-3.5, 3.5-4, 4-4.5, 4.5-5 seconds, time periods between the foregoing ranges, etc.) after loss of capture has been achieved. In other embodiments, the delivery of energy can continue for a time period greater than 5 seconds after loss of capture (e.g., 5-6, 6-7, 7-8, 8-9, 9-10, 10-15, 15-20, 20-30 seconds, time periods between the foregoing ranges, greater than 30 seconds, etc.). In some embodiments, such a protocol or configuration can help ensure that proper ablation has been accomplished.

**[0104]** According to some embodiments, the confirmation of completed ablation using the pacing of cardiac tissue and the subsequent loss of capture can be used either in lieu of or in addition to other metrics, techniques, tools and/or methods, such as, for example, ECG amplitude reductions, visual evidence of lesion formation (e.g., fluoro and/or ultrasound imaging, other imaging, etc.) and/or the like, regardless of whether such confirmation tools are specifically disclosed herein. For example, in some embodiments, the confirmation procedures relating to pacing and loss of capture are used as the sole or primary method of confirming proper ablation of targeted tissue. However, in other configurations, the use of such techniques and methods can be used to confirm or otherwise validate results and data obtained using one or more other techniques or methods, as desired or required.

**[0105]** With continued reference to the schematic of FIG. 9, the system 2000 can additionally include (or be operatively coupled with) an EP recording system 2310 through which various mapping and other signals (e.g., ECG signals) are received and/or processed. In some embodiments, one or more output devices 2340, 2342 (e.g., displays, other screens, etc.) can be provided to visually display data and/or other information relevant to a procedure being conducted by the system 2000. For example, in some embodiments, the displays and/or other output devices 2340, 2342 can be configured to receive pacing or heart rate data obtained using the high-resolution electrode(s) or electrode portion (s), ECG data (e.g., obtained from high-resolution electrodes or electrode portions), tissue contact data, imaging data and graphical representations and/or the like. Further, in order to obtain, collect and/or process the necessary data, the system 2000 can include one or more of the following: a return electrode 2250 (e.g. positioned along the lower portion of a subject P), an ECG cable that operatively couples the system 2000 to surface and/or other ECG electrodes (e.g., to provide ECG data before, during and/or after a procedure) and/or the like.

**[0106]** FIG. 10 illustrates one embodiment of a graphical data output 2500 (e.g., as provided by the system to a display or other output device). As shown, the graphical output 2500 comprises various charts indicative of one or more data sets obtained by an ablation system before, during and after the execution of an ablation procedure. For example, in the illustrated embodiment, graphs 2510 are provided regarding ECG data that are obtained by the electrodes of the catheter. Further, the output 2500 comprises a graphical representation 2530 of the heart rate. In some embodiments, as discussed herein, a pacing signal can be provided to the system (e.g., via a pacemaker device or system that is operatively coupled to the RF generator or other energy delivery module) to increase the heart rate of the subject being treated. This is visible in the embodiment of FIG. 10 when the graphical representation 2530 of the heart rate of the subject increases (e.g., the rate of cardiac activity of the subject increases). Once sufficient RF and/or other energy has been delivered to the targeted tissue adjacent the high-resolution electrode, in accordance with the foregoing disclosure, the post-ablation pacing threshold will exceed the amplitude of the pacing current, as a confirmation that ablating the targeted tissue was successful in rendering such tissue non-viable. Accordingly, the measured heart rate will drop, providing graphical confirmation 2340 of loss of capture to a user. As noted herein, once loss of capture has

been confirmed, the user manually (and/or the system, e.g., automatically) can terminate an ablation procedure, either immediately or following a desired period, in accordance with a particular protocol or treatment technique.

**[0107]** According to some embodiments, due to the nature of the high-resolution-tip electrode systems that are used to create a more complete and comprehensive map of targeted tissue, in accordance with the various high-resolution-tip systems and devices disclosed herein, additional information regarding the position of the roving catheter (and thus, the intermediate mapping locations) can be obtained and provided to the user during a procedure. For example, given the high-resolution mapping capabilities of such catheters, information can be obtained regarding the nature, type and other details regarding the tissue that is adjacent the electrode. In addition, as noted above, the high-resolution-tip embodiments disclosed herein can help determine whether a specific tissue region has been adequately ablated (e.g., see the disclosure above with reference to FIG. 8).

**[0108]** In some embodiments, any of the high-resolution-tip electrode devices or systems disclosed herein can be used as stand-alone mapping systems to accurately assess the condition of a subject's targeted anatomical region, even with the use of a separate mapping system. For example, a user can move a high-resolution-tip electrode catheter or other medical instrument to various locations within a subject's anatomy to generate a detailed, accurate and complete electrical map, as desired or required.

**[0109]** As a result of the high-resolution mapping capabilities of the various high-resolution-tip electrode catheter devices and systems disclosed herein, an accurate map of the subject's targeted anatomical space or other region can be obtained. In addition, in view of the fact that such systems are also configured to advantageously ablate tissue, a more efficient and accurate treatment procedure can be attained. For example, in embodiments where one of the high-resolution-tip electrodes devices or systems disclosed herein is being used to map a subject's anatomy (e.g., atrium), either with or without the use of a separate (e.g., commercially-available mapping system), such a high-resolution-tip device or system can be used to also ablate tissue. This can facilitate and improve the execution of a treatment procedure. For example, the ability to use a single device to both map and ablate tissue permits a user to more expeditiously perform an overall assessment and treatment of a subject. In addition, the ability to create a more comprehensive map of the subject's tissue, allows a user to perform a subject treatment procedure with greater accuracy and precision. As discussed, this can help reduce the overall (and sometimes unnecessary) trauma to the subject, improve recovery and provide for better and effective treatment of the subject's disease. In addition, as noted above, the ability of the user to determine whether tissue has already been ablated or otherwise treated to a sufficient level can further improve the efficacy, efficiency and/or safety of a procedure.

**[0110]** In some embodiments, the system comprises various features that are present as single features (as opposed to multiple features). For example, in one embodiment, the system includes a single catheter that is configured to obtain high-resolution mapping of tissue. The system can include a single energy delivery module (e.g., a generator) for supplying ablative or other energy to the catheter. The system can further include a single processor that is configured to regulate the delivery of energy from the energy delivery

module to the catheter. The catheter can include a split-tip electrode design and/or any other high-resolution configuration. The system can include a single pacemaker (e.g., that is integrated with or separate from the energy delivery module and/or any other component of the system) to selectively pace or increase the heartrate of a subject's heart.

**[0111]** According to some embodiments, the system consists essentially of a catheter that is configured to obtain high-resolution mapping of tissue, an energy delivery module (e.g., a RF or other generator) for supplying ablative or other energy to the catheter, and a processor that is configured to regulate the delivery of energy from the energy delivery module to the catheter. According to some embodiments, the system consists essentially of a catheter that is configured to obtain high-resolution mapping of tissue, an energy delivery module (e.g., a RF or other generator) for supplying ablative or other energy to the catheter, a processor that is configured to regulate the delivery of energy from the energy delivery module to the catheter and a pacemaker for selectively pacing the heart of the subject being treated.

**[0112]** In some embodiments, the system comprises one or more of the following: means for tissue modulation (e.g., an ablation or other type of modulation catheter or delivery device), means for generating energy (e.g., a generator or other energy delivery module), means for connecting the means for generating energy to the means for tissue modulation (e.g., an interface or input/output connector or other coupling member), means for increasing the heartrate of a subject being treated (e.g., using a pacemaker that is integrated with or separate from one or more components of the system), etc.

**[0113]** Any methods described herein may be embodied in, and partially or fully automated via, software code modules executed by one or more processors or other computing devices. The methods may be executed on the computing devices in response to execution of software instructions or other executable code read from a tangible computer readable medium. A tangible computer readable medium is a data storage device that can store data that is readable by a computer system. Examples of computer readable mediums include read-only memory, random-access memory, other volatile or non-volatile memory devices, CD-ROMs, magnetic tape, flash drives, and optical data storage devices.

**[0114]** In addition, embodiments may be implemented as computer-executable instructions stored in one or more tangible computer storage media. As will be appreciated by a person of ordinary skill in the art, such computer-executable instructions stored in tangible computer storage media define specific functions to be performed by computer hardware such as computer processors. In general, in such an implementation, the computer-executable instructions are loaded into memory accessible by at least one computer processor. The at least one computer processor then executes the instructions, causing computer hardware to perform the specific functions defined by the computer-executable instructions. As will be appreciated by a person of ordinary skill in the art, computer execution of computer-executable instructions is equivalent to the performance of the same functions by electronic hardware that includes hardware circuits that are hardwired to perform the specific functions. As such, while embodiments illustrated herein are typically implemented as some combination of computer hardware and computer-executable instructions, the embodiments

illustrated herein could also be implemented as one or more electronic circuits hardwired to perform the specific functions illustrated herein.

**[0115]** The various systems, devices and/or related methods disclosed herein can be used to at least partially ablate and/or otherwise ablate, heat or otherwise thermally treat one or more portions of a subject's anatomy, including without limitation, cardiac tissue (e.g., myocardium, atrial tissue, ventricular tissue, valves, etc.), a bodily lumen (e.g., vein, artery, airway, esophagus or other digestive tract lumen, urethra and/or other urinary tract vessels or lumens, other lumens, etc.), sphincters, other organs, tumors and/or other growths, nerve tissue and/or any other portion of the anatomy. The selective ablation and/or other heating of such anatomical locations can be used to treat one or more diseases or conditions, including, for example, atrial fibrillation, mitral valve regurgitation, other cardiac diseases, asthma, chronic obstructive pulmonary disease (COPD), other pulmonary or respiratory diseases, including benign or cancerous lung nodules, hypertension, heart failure, denervation, renal failure, obesity, diabetes, gastroesophageal reflux disease (GERD), other gastroenterological disorders, other nerve-related disease, tumors or other growths, pain and/or any other disease, condition or ailment.

**[0116]** In any of the embodiments disclosed herein, one or more components, including a processor, computer-readable medium or other memory, controllers (for example, dials, switches, knobs, etc.), displays (for example, temperature displays, timers, etc.) and/or the like are incorporated into and/or coupled with (for example, reversibly or irreversibly) one or more modules of the generator, the irrigation system (for example, irrigant pump, reservoir, etc.) and/or any other portion of an ablation or other modulation system.

**[0117]** Although several embodiments and examples are disclosed herein, the present application extends beyond the specifically disclosed embodiments to other alternative embodiments and/or uses of the inventions and modifications and equivalents thereof. It is also contemplated that various combinations or subcombinations of the specific features and aspects of the embodiments may be made and still fall within the scope of the inventions. Accordingly, it should be understood that various features and aspects of the disclosed embodiments can be combine with or substituted for one another in order to form varying modes of the disclosed inventions. Thus, it is intended that the scope of the present inventions herein disclosed should not be limited by the particular disclosed embodiments described above, but should be determined only by a fair reading of the claims that follow.

**[0118]** While the embodiments disclosed herein are susceptible to various modifications, and alternative forms, specific examples thereof have been shown in the drawings and are herein described in detail. It should be understood, however, that the inventions are not to be limited to the particular forms or methods disclosed, but, to the contrary, the inventions are to cover all modifications, equivalents, and alternatives falling within the spirit and scope of the various embodiments described and the appended claims. Any methods disclosed herein need not be performed in the order recited. The methods disclosed herein include certain actions taken by a practitioner; however, they can also include any third-party instruction of those actions, either expressly or by implication. For example, actions such as "advancing a catheter" or "delivering energy to an ablation

member” include “instructing advancing a catheter” or “instructing delivering energy to an ablation member,” respectively. The ranges disclosed herein also encompass any and all overlap, sub-ranges, and combinations thereof. Language such as “up to,” “at least,” “greater than,” “less than,” “between,” and the like includes the number recited. Numbers preceded by a term such as “about” or “approximately” include the recited numbers. For example, “about 10 mm” includes “10 mm.” Terms or phrases preceded by a term such as “substantially” include the recited term or phrase. For example, “substantially parallel” includes “parallel.”

What is claimed is:

1. An energy delivery module configured to deliver ablative energy to targeted cardiac tissue of a subject and for confirming successful ablation of said targeted cardiac tissue, comprising:

a processor for regulating the delivery of ablative energy; wherein the energy delivery module is configured to operatively couple to a catheter, wherein the energy delivery module is configured to energize an electrode positioned along a distal end of the catheter to selectively ablate targeted cardiac tissue adjacent the electrode;

wherein the energy delivery module is configured to couple to a pacemaker for selectively pacing cardiac tissue in order to attain capture of the heart of the subject;

wherein the processor is configured, via a predetermined pacing signal provided to the catheter by a pacemaker, to increase the heart rate of the subject from a baseline level to an elevated level, the predetermined pacing signal comprising a pacing level greater than a pre-ablation pacing threshold level; and

wherein the processor is configured to terminate the delivery of energy to the electrode after loss of capture of the heart of the subject.

2. The energy delivery module of claim 1, further comprising a pacemaker, wherein the pacemaker is integrated within the module.

3. The energy delivery module of claim 1, further comprising a pacemaker.

4. The energy delivery module of claim 1, wherein the pacemaker is integrated within the module.

5. The energy delivery module of claim 1, wherein the pacemaker is separate from the module.

6. A kit for delivering ablative energy to targeted cardiac tissue of a subject and for confirming successful ablation of said targeted cardiac tissue, comprising:

a catheter comprising a high-resolution electrode along a distal end of the catheter; and

an energy delivery module comprising a processor, wherein the processor is configured to regulate the delivery of ablative energy;

wherein the energy delivery module is configured to operatively couple to the catheter, wherein the energy delivery module is configured to energize the electrode positioned along a distal end of the catheter to selectively ablate targeted cardiac tissue adjacent the electrode;

wherein the energy delivery module is configured to couple to a pacemaker for selectively pacing cardiac tissue in order to attain capture of the heart of the subject;

wherein the processor is configured, via a predetermined pacing signal provided to the catheter by a pacemaker, to increase the heart rate of the subject from a baseline level to an elevated level, the predetermined pacing signal comprising a pacing level greater than a pre-ablation pacing threshold level; and

wherein the processor is configured to terminate the delivery of energy to the electrode after loss of capture of the heart of the subject.

7. The kit of claim 6, further comprising the pacemaker, wherein the pacemaker is separate from the energy delivery module.

8. The kit of claim 6, further comprising the pacemaker.

9. The kit of claim 6, wherein the pacemaker is integrated within the energy delivery module.

10. The kit of claim 6, wherein the pacemaker is separate from the energy delivery module.

11. A generator configured to deliver ablative energy to targeted cardiac tissue of a subject and for confirming successful ablation of said targeted cardiac tissue, comprising:

an energy delivery module configured to generate ablative energy for delivery to an ablation device; and

a processor configured to regulate the delivery of ablative energy from the energy delivery module to an electrode of the ablation device;

wherein ablative energy generated by the energy delivery module is delivered to the electrode assembly;

wherein the energy delivery module is configured to couple to a pacemaker for selectively pacing cardiac tissue in order to attain capture of the heart of the subject;

wherein the processor is configured, via a predetermined pacing signal provided to the catheter by a pacemaker, to increase the heart rate of the subject from a baseline level to an elevated level, the predetermined pacing signal comprising a pacing level greater than a pre-ablation pacing threshold level; and

wherein the processor is configured to terminate the delivery of energy to the electrode after loss of capture of the heart of the subject.

12. The generator of claim 11, wherein the energy delivery module is configured to generate radiofrequency (RF) energy.

13. The generator of claim 11, wherein the processor and the energy delivery module are located within a single housing or enclosure.

14. The generator of claim 11, wherein the processor and the energy delivery module are located within separate housings or enclosures.

15. The generator of claim 11, further comprising the pacemaker.

16. The generator of claim 15, wherein the pacemaker is integral to the energy delivery module.

17. The generator of claim 15, wherein the pacemaker is separate from the energy delivery module.

18. The generator of claim 11, wherein the electrode comprising a high-resolution electrode.

**19.** The generator of claim **18**, wherein the high resolution electrode comprises a distal portion and a proximal portion, the distal and proximal portions of the high-resolution electrode being operatively coupled to each other using at least one filtering element.

**20.** The generator of claim **19**, wherein the at least one filtering element comprises a capacitor.

\* \* \* \* \*

专利名称(译)	组织的高分辨率绘图与起搏		
公开(公告)号	<a href="#">US20190125427A1</a>	公开(公告)日	2019-05-02
申请号	US16/231304	申请日	2018-12-21
[标]发明人	PANESCU DORIN		
发明人	PANESCU, DORIN		
IPC分类号	A61B18/12 A61N1/365 A61B5/042 A61B5/00 A61B18/14 A61N1/05 A61N1/37		
CPC分类号	A61B18/1206 A61N1/36514 A61B5/4836 A61B18/12 A61B18/1492 A61N1/0565 A61N1/371 A61B18/14 A61B5/0402 A61B2018/00577 A61B2018/00666 A61B5/042		
优先权	62/081710 2014-11-19 US 62/193547 2015-07-16 US		
外部链接	<a href="#">Espacenet</a> <a href="#">USPTO</a>		

摘要(译)

根据一些实施例，使用高分辨率绘图电极确认对象的目标心脏组织的成功消融的方法包括以预定的起搏水平起搏所述心脏组织以将对象的心率从基线水平增加到高于水平，预定起搏水平大于消融前起搏阈值水平但低于消融后起搏阈值水平，向消融电极输送消融能量，检测受试者的心率，其中心率检测到在达到消融后起搏阈值水平之前，高分辨率标测电极处于升高的水平，并且其中一旦消融达到其治疗目标或目标，并且其中由高分辨率标测电极检测到的心率降至低于升高的水平，并且终止在心率下降到低于升高的水平之后，将消融能量传递到消融电极。

