



US 20190076028A1

(19) **United States**

(12) **Patent Application Publication**
Al-Ali et al.

(10) **Pub. No.: US 2019/0076028 A1**
(43) **Pub. Date: Mar. 14, 2019**

(54) **PLETHYSMOGRAPHIC RESPIRATION RATE DETECTION**

A61B 5/029 (2006.01)
A61B 5/02 (2006.01)
A61B 5/1455 (2006.01)

(71) Applicant: **MASIMO CORPORATION**, Irvine, CA (US)

(52) **U.S. Cl.**
CPC *A61B 5/0205* (2013.01); *A61B 5/08* (2013.01); *A61B 5/0295* (2013.01); *A61B 5/0816* (2013.01); *A61B 5/7228* (2013.01); *A61B 5/725* (2013.01); *A61B 5/7253* (2013.01); *A61B 5/7278* (2013.01); *A61B 5/7225* (2013.01); *A61B 5/7203* (2013.01); *A61B 5/6826* (2013.01); *A61B 5/029* (2013.01); *A61B 5/7475* (2013.01); *A61B 5/02007* (2013.01); *A61B 5/746* (2013.01); *A61B 5/742* (2013.01); *A61B 5/7405* (2013.01); *A61B 5/7264* (2013.01); *A61B 5/0806* (2013.01); *A61B 5/14552* (2013.01); *A61B 5/0261* (2013.01)

(72) Inventors: **Ammar Al-Ali**, San Juan Capistrano, CA (US); **Anmol Majmudar**, Irvine, CA (US)

(21) Appl. No.: **16/119,215**

(22) Filed: **Aug. 31, 2018**

Related U.S. Application Data

(60) Continuation of application No. 15/095,912, filed on Apr. 11, 2016, now Pat. No. 10,098,550, which is a division of application No. 13/076,423, filed on Mar. 30, 2011, now Pat. No. 9,307,928.

(60) Provisional application No. 61/319,256, filed on Mar. 30, 2010, provisional application No. 61/364,141, filed on Jul. 14, 2010.

Publication Classification

(51) **Int. Cl.**
A61B 5/0205 (2006.01)
A61B 5/026 (2006.01)
A61B 5/0295 (2006.01)
A61B 5/08 (2006.01)
A61B 5/00 (2006.01)

(57) **ABSTRACT**

A plethysmographic respiration processor is responsive to respiratory effects appearing on a blood volume waveform and the corresponding detected intensity waveform measured with an optical sensor at a blood perfused peripheral tissue site so as to provide a measurement of respiration rate. A preprocessor identifies a windowed pleth corresponding to a physiologically acceptable series of plethysmograph waveform pulses. Multiple processors derive different parameters responsive to particular respiratory effects on the windowed pleth. Decision logic determines a respiration rate based upon at least a portion of these parameters.

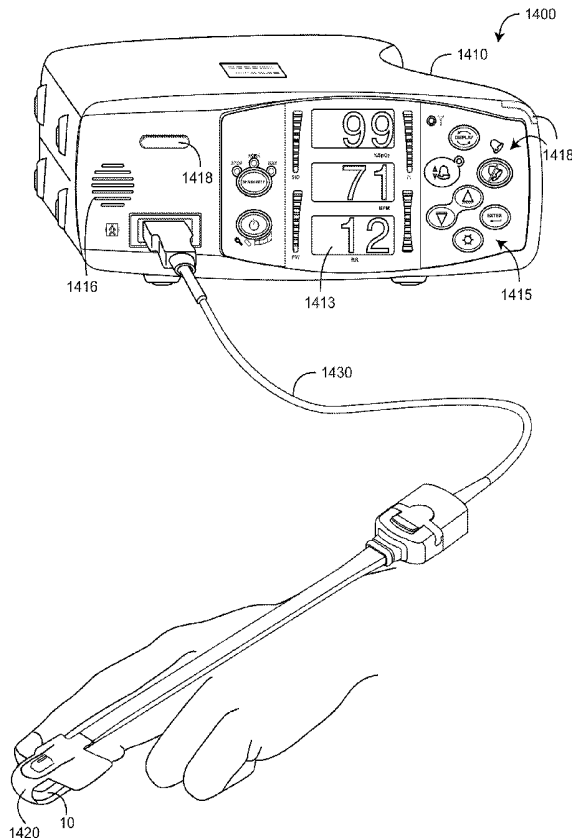

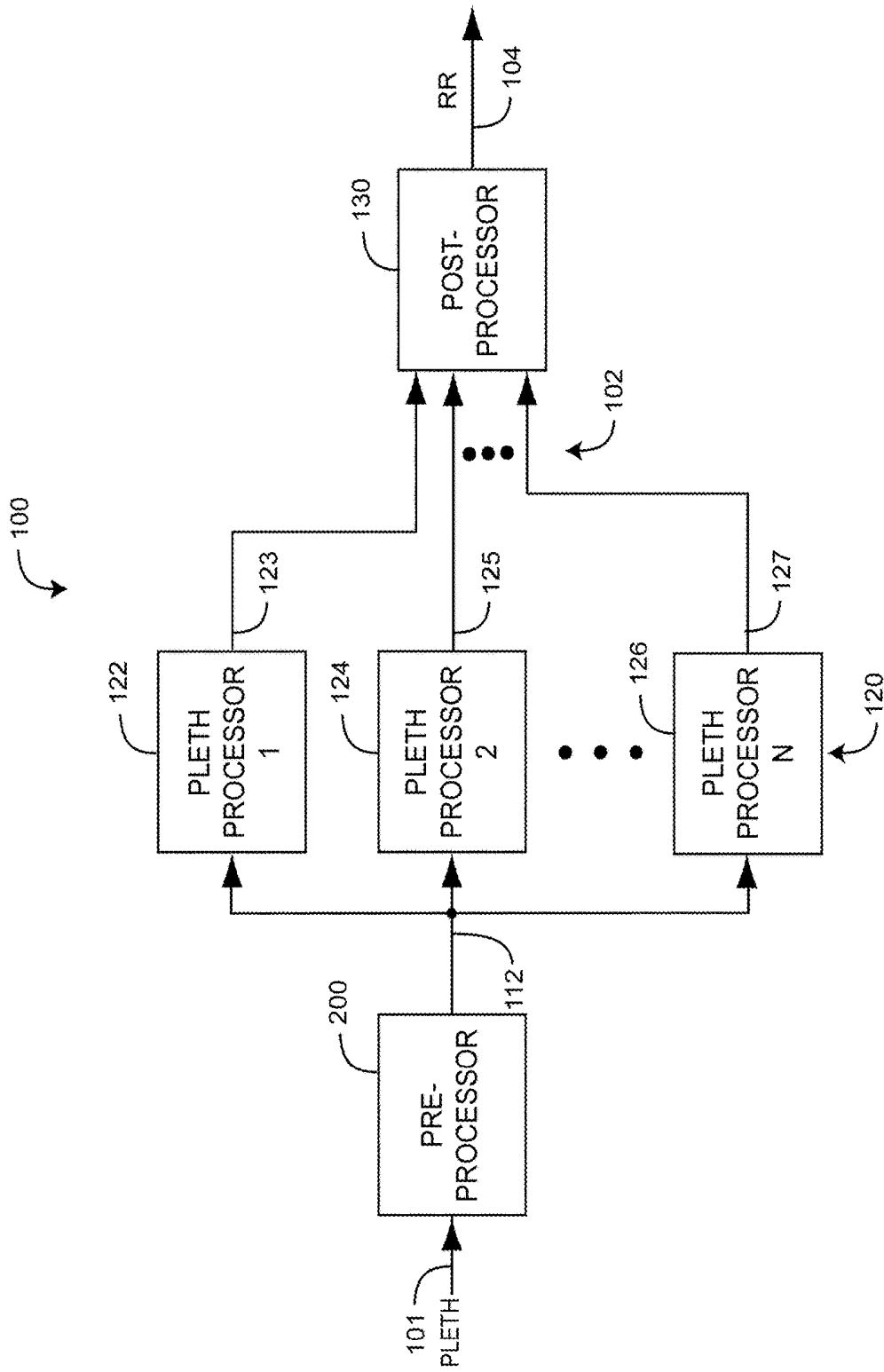

FIG. 1

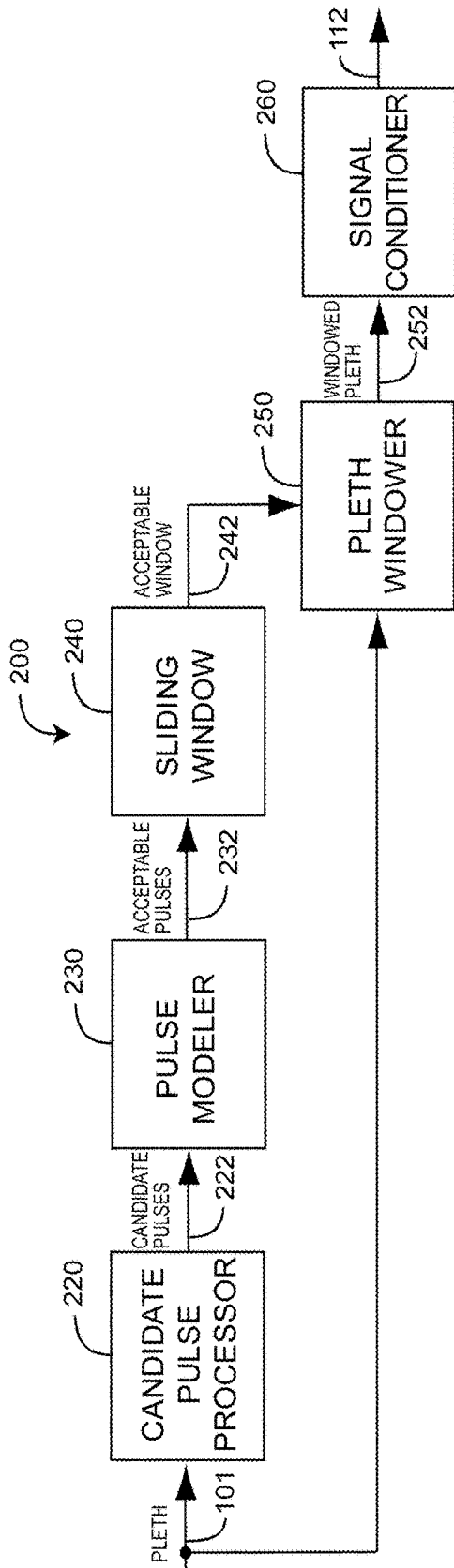

FIG. 2A

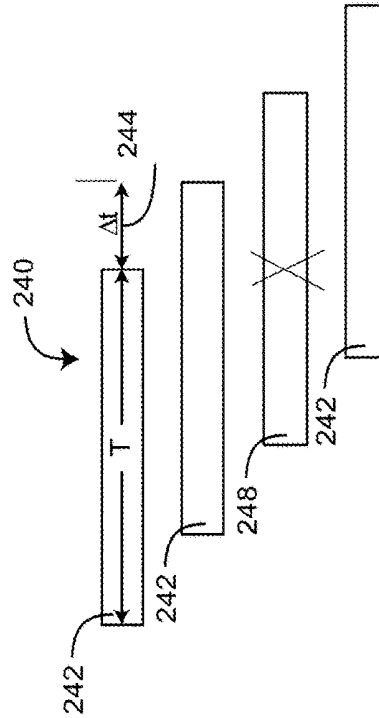

FIG. 2B

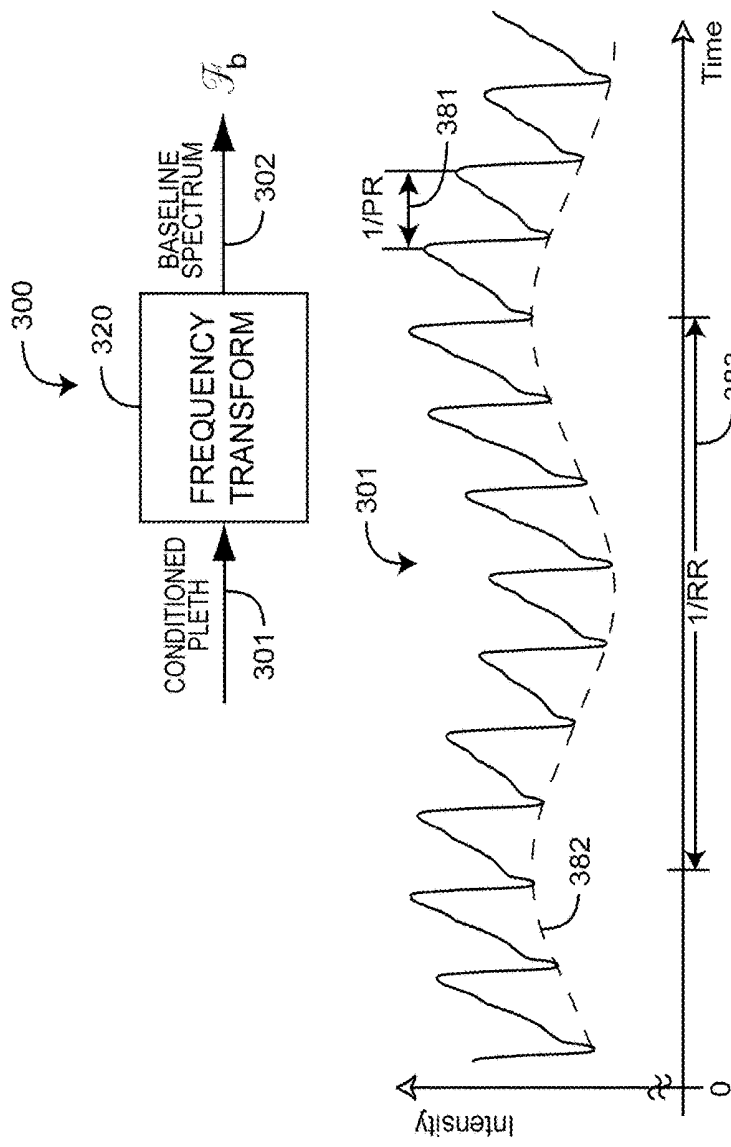

FIG. 3A

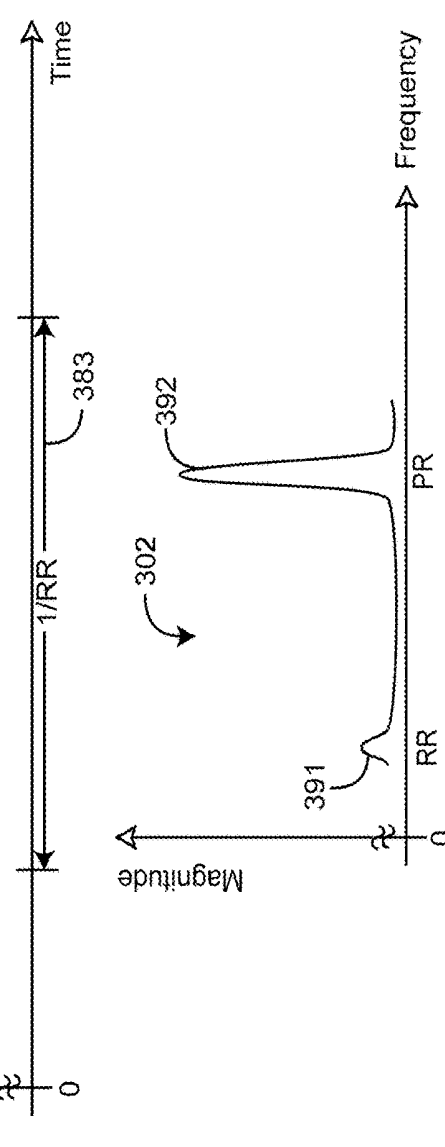

FIG. 3B



FIG. 3C

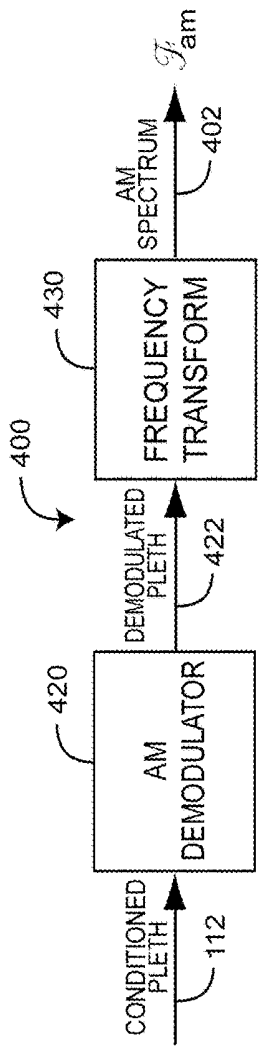

FIG. 4A

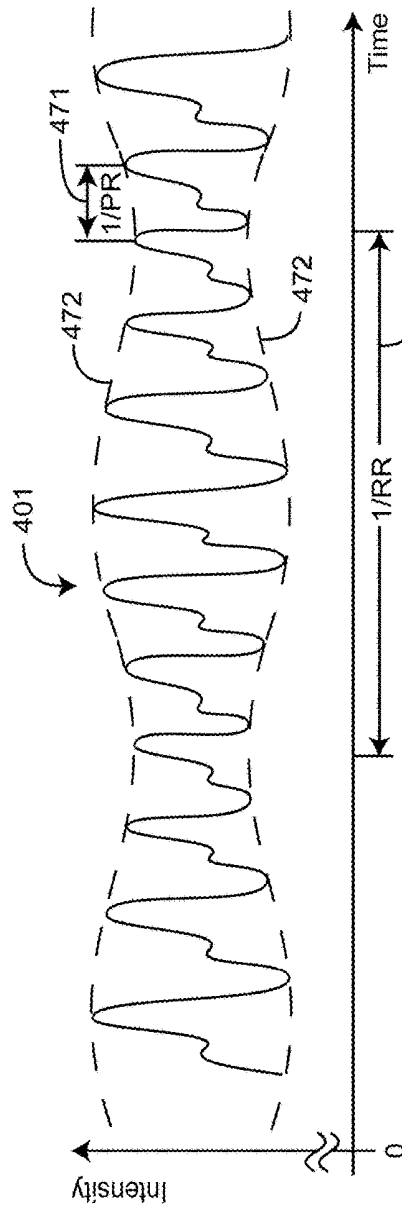

FIG. 4B

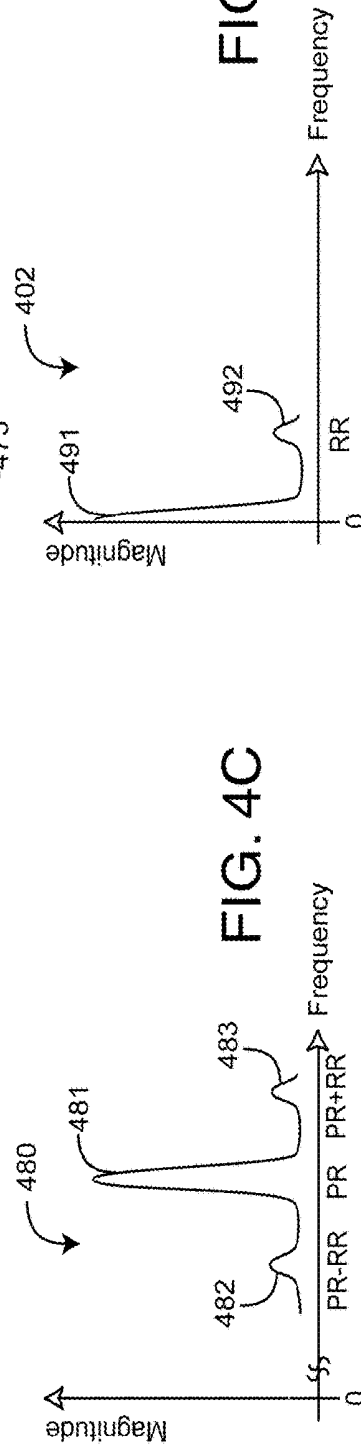

FIG. 4C

FIG. 4D

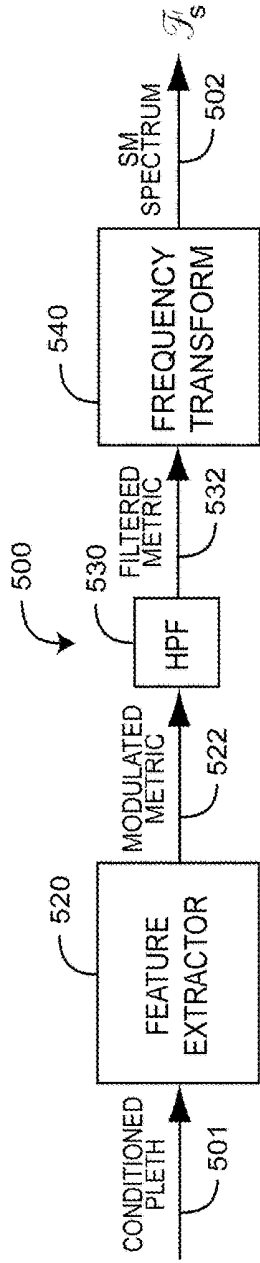

FIG. 5A

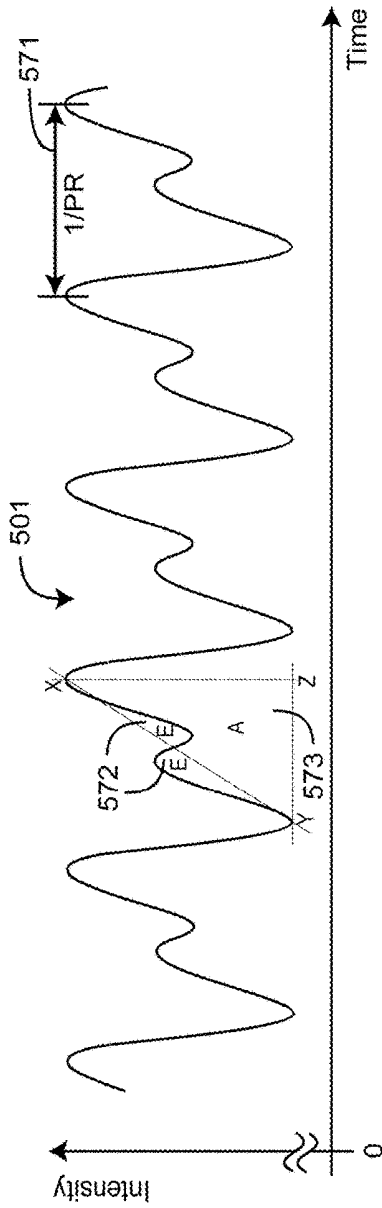

FIG. 5B

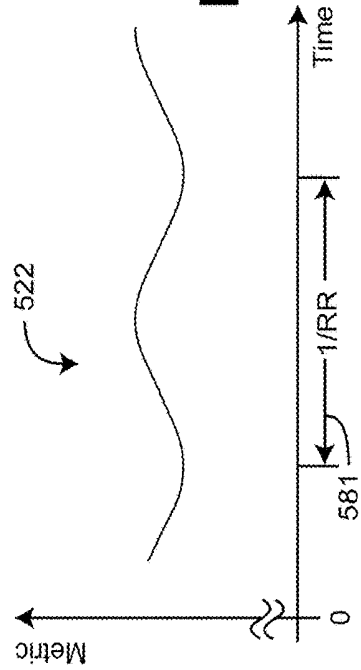

FIG. 5C

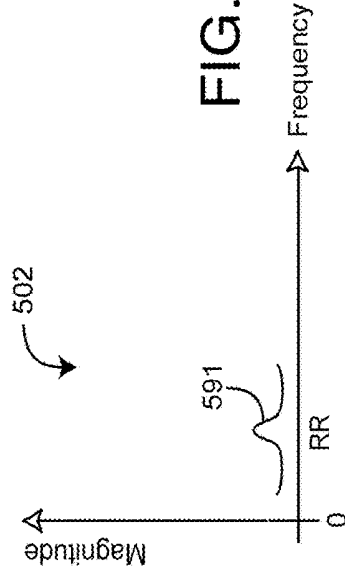

FIG. 5D

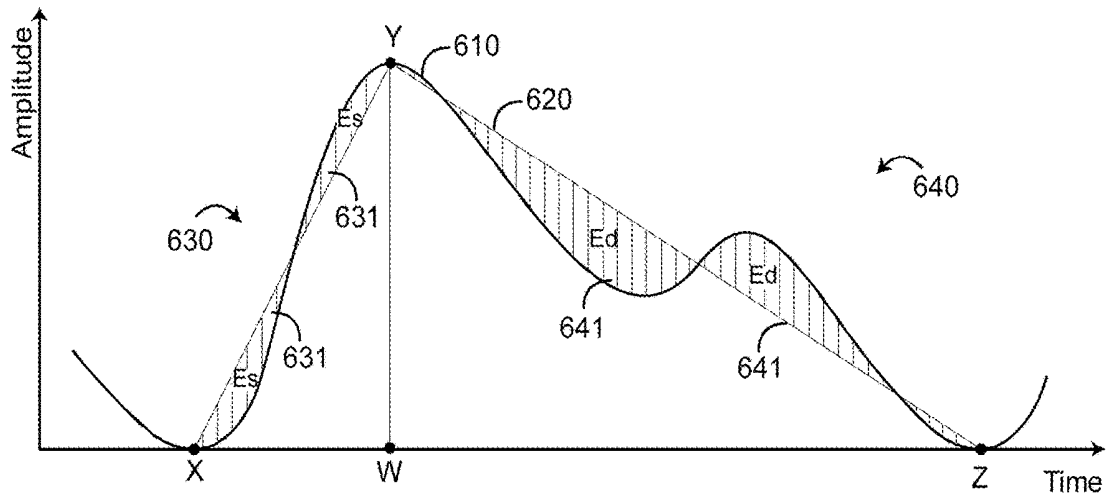

FIG. 6A

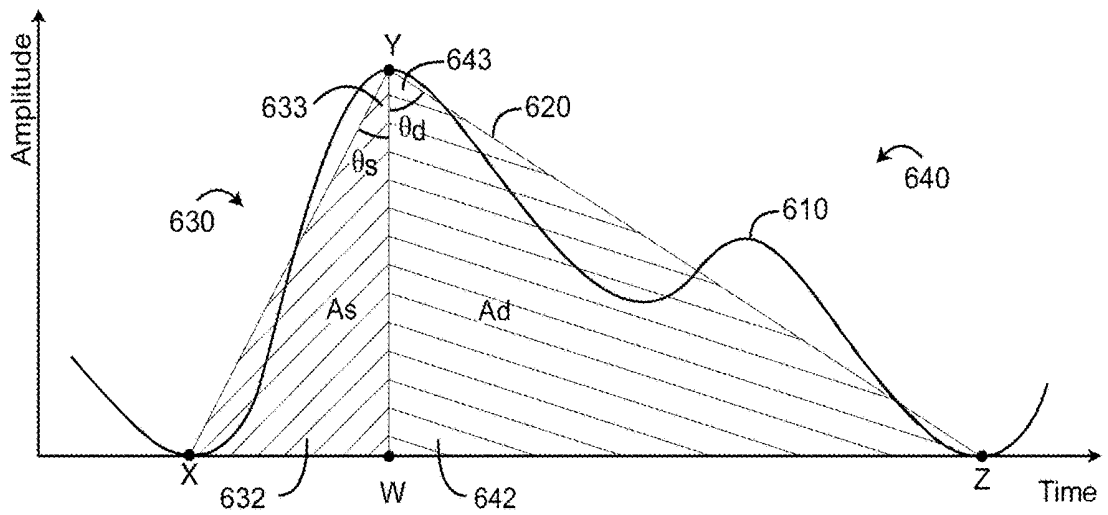

FIG. 6B

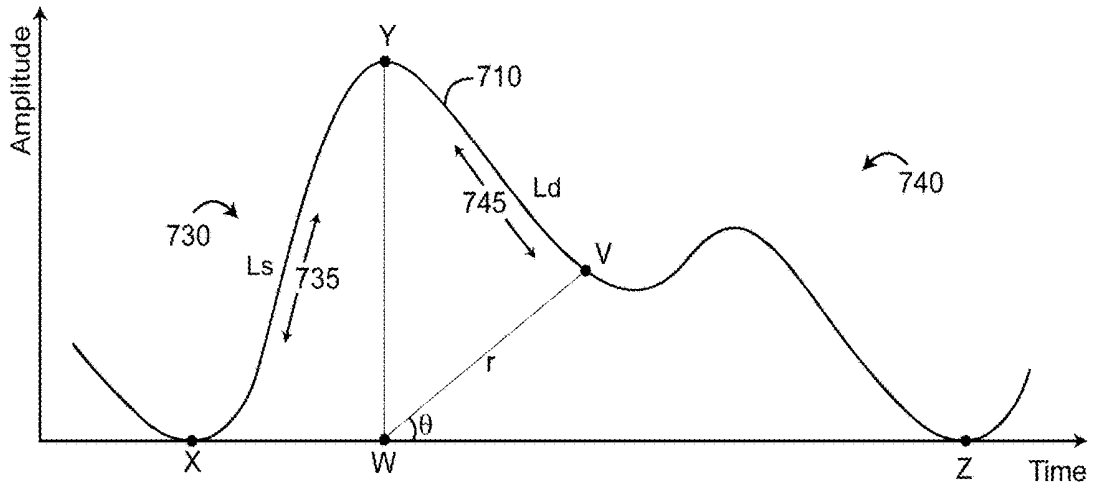

FIG. 7A

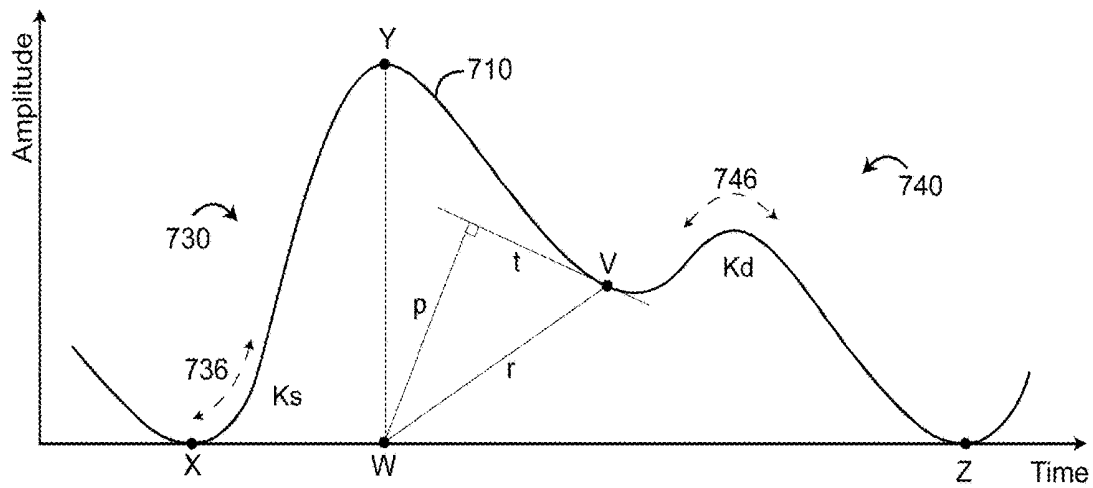

FIG. 7B

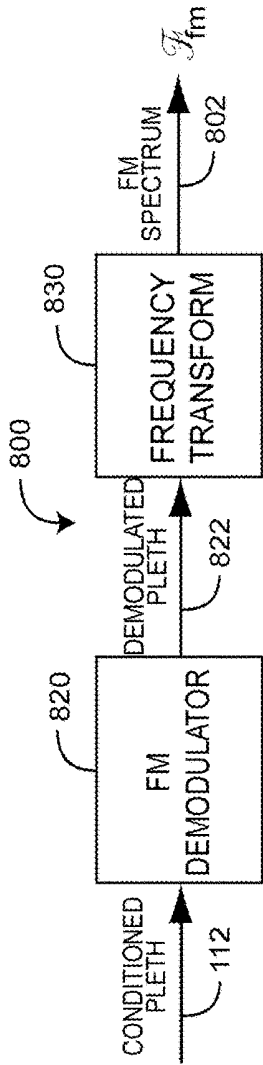

FIG. 8A

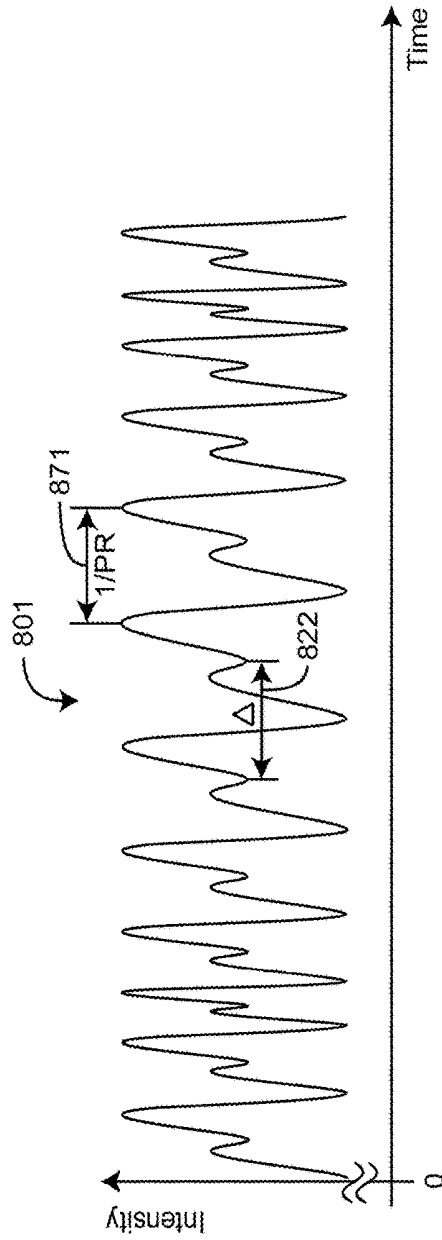

FIG. 8B

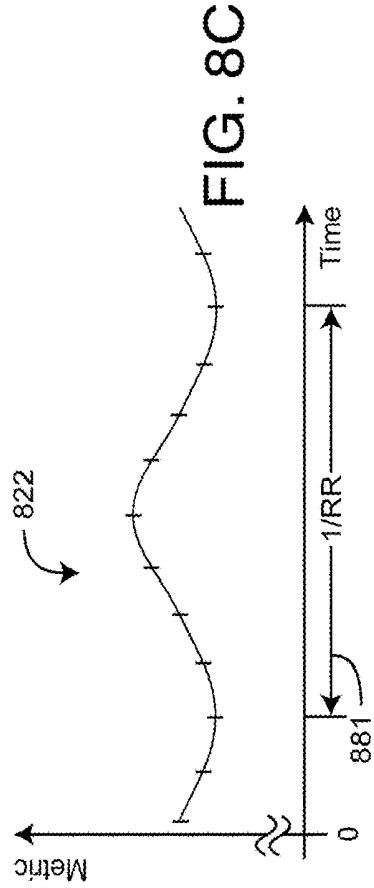

FIG. 8C

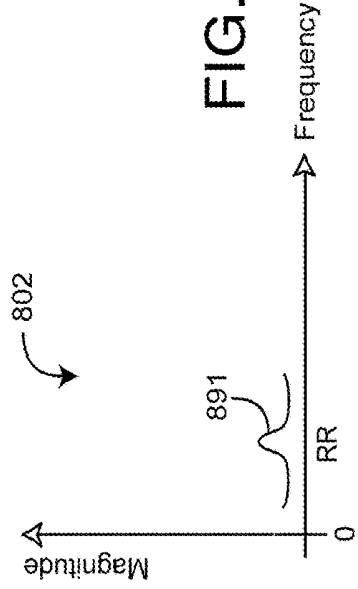

FIG. 8D

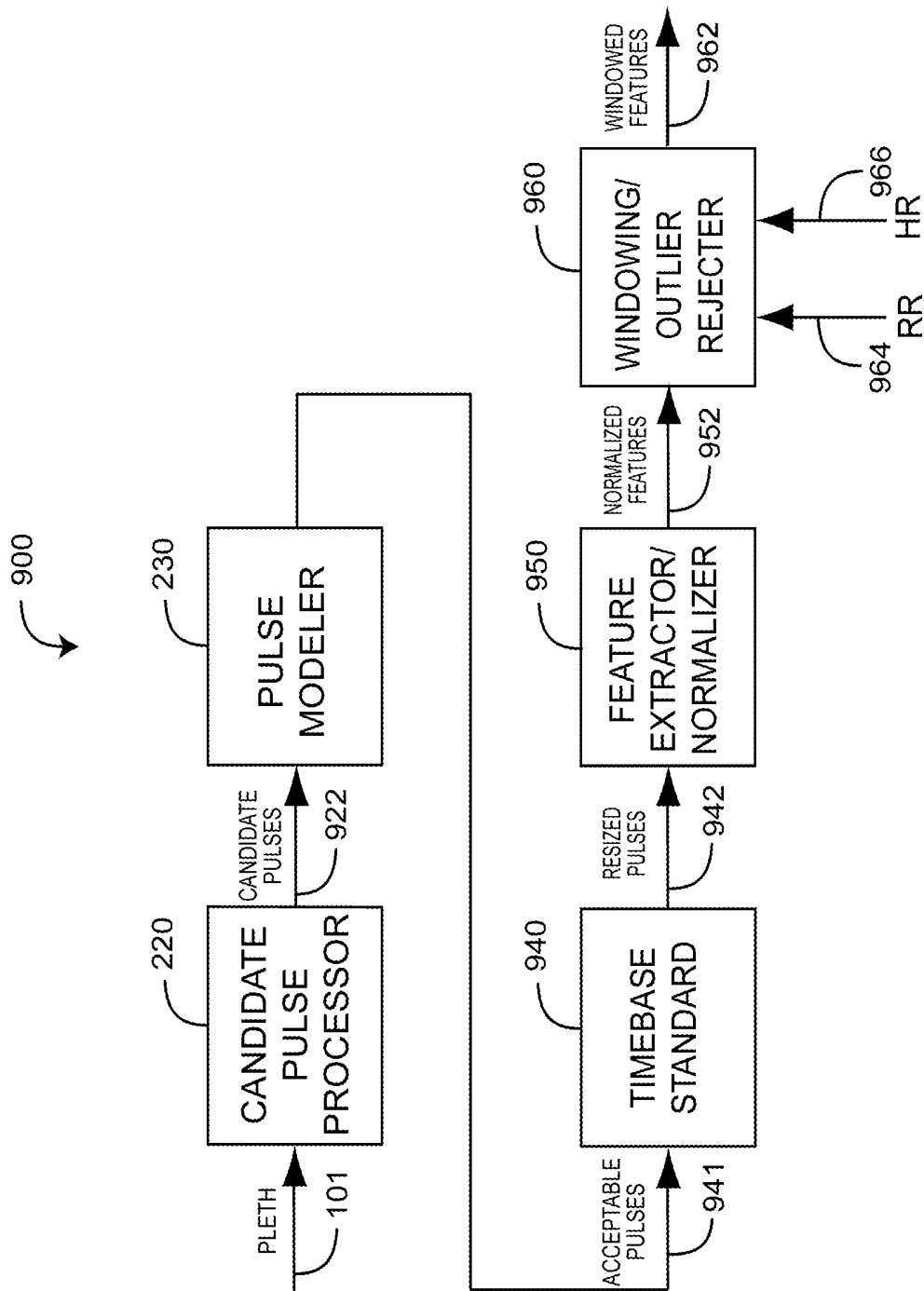

FIG. 9

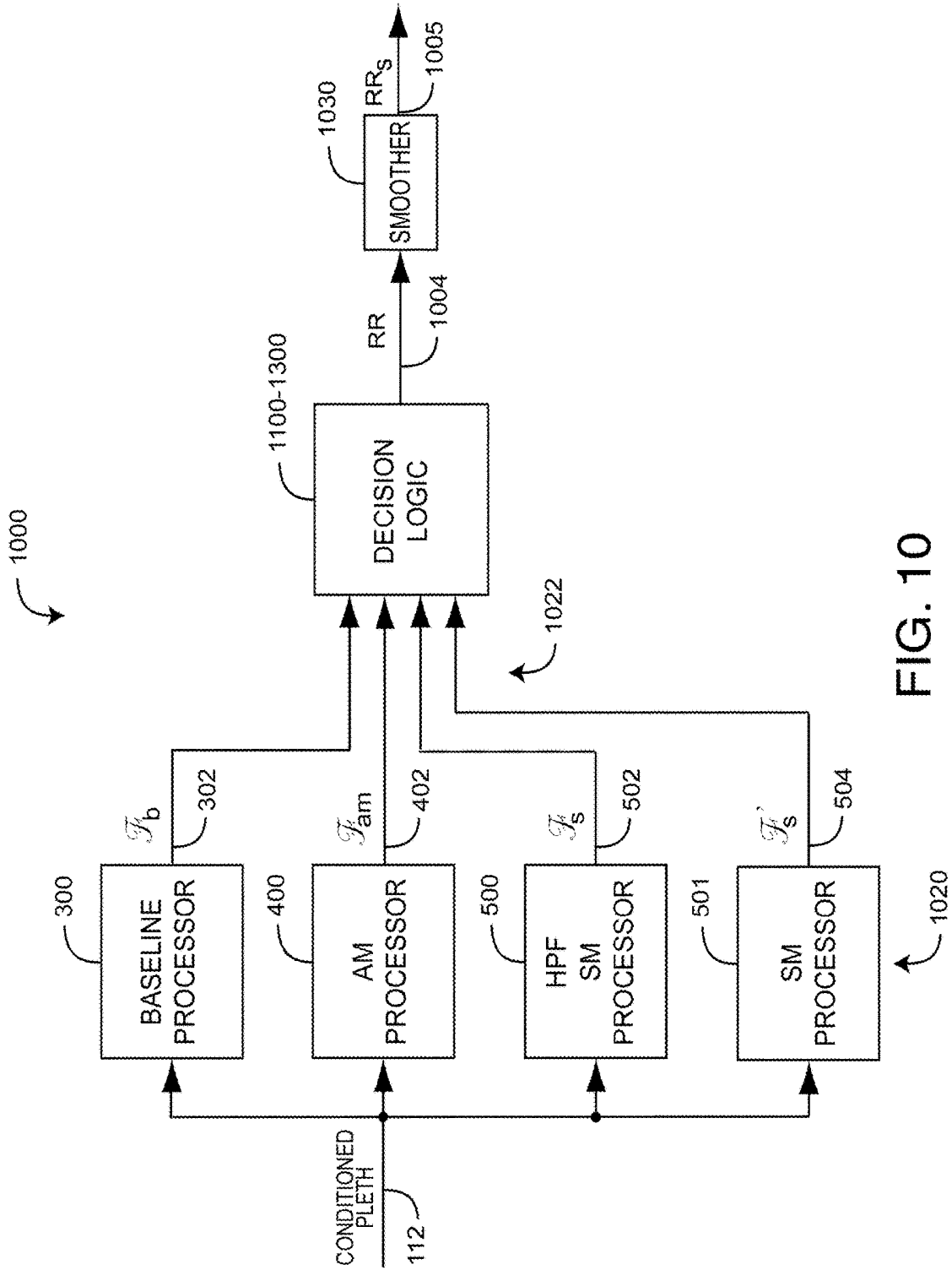

FIG. 10

FIG. 11A

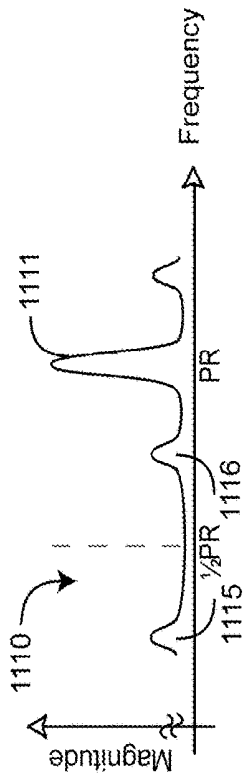

FIG. 11B

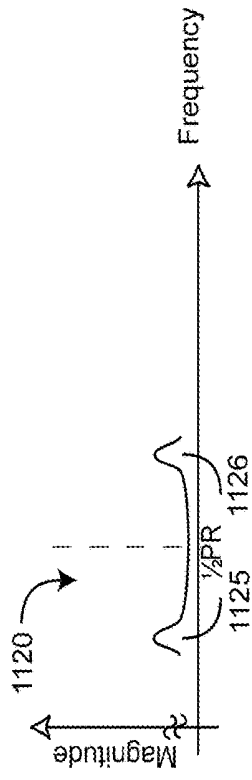

FIG. 11C

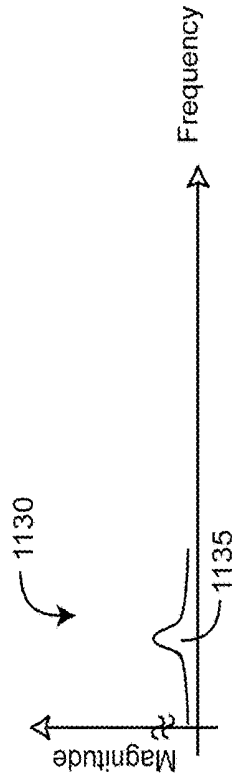
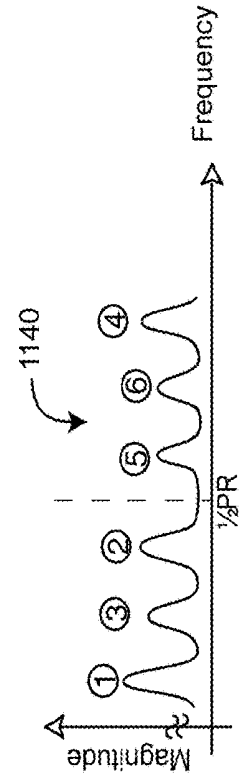

FIG. 11D



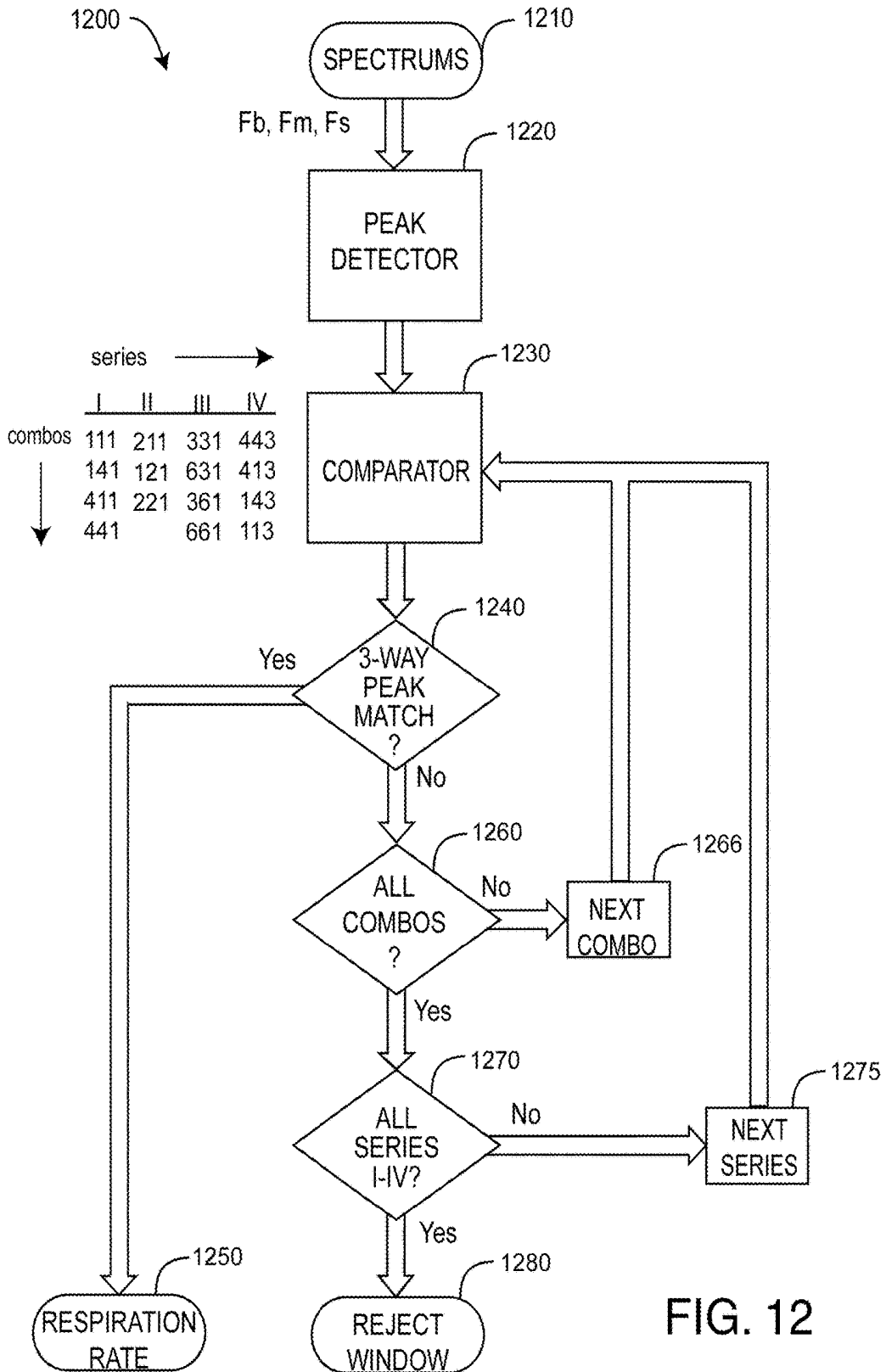

FIG. 12

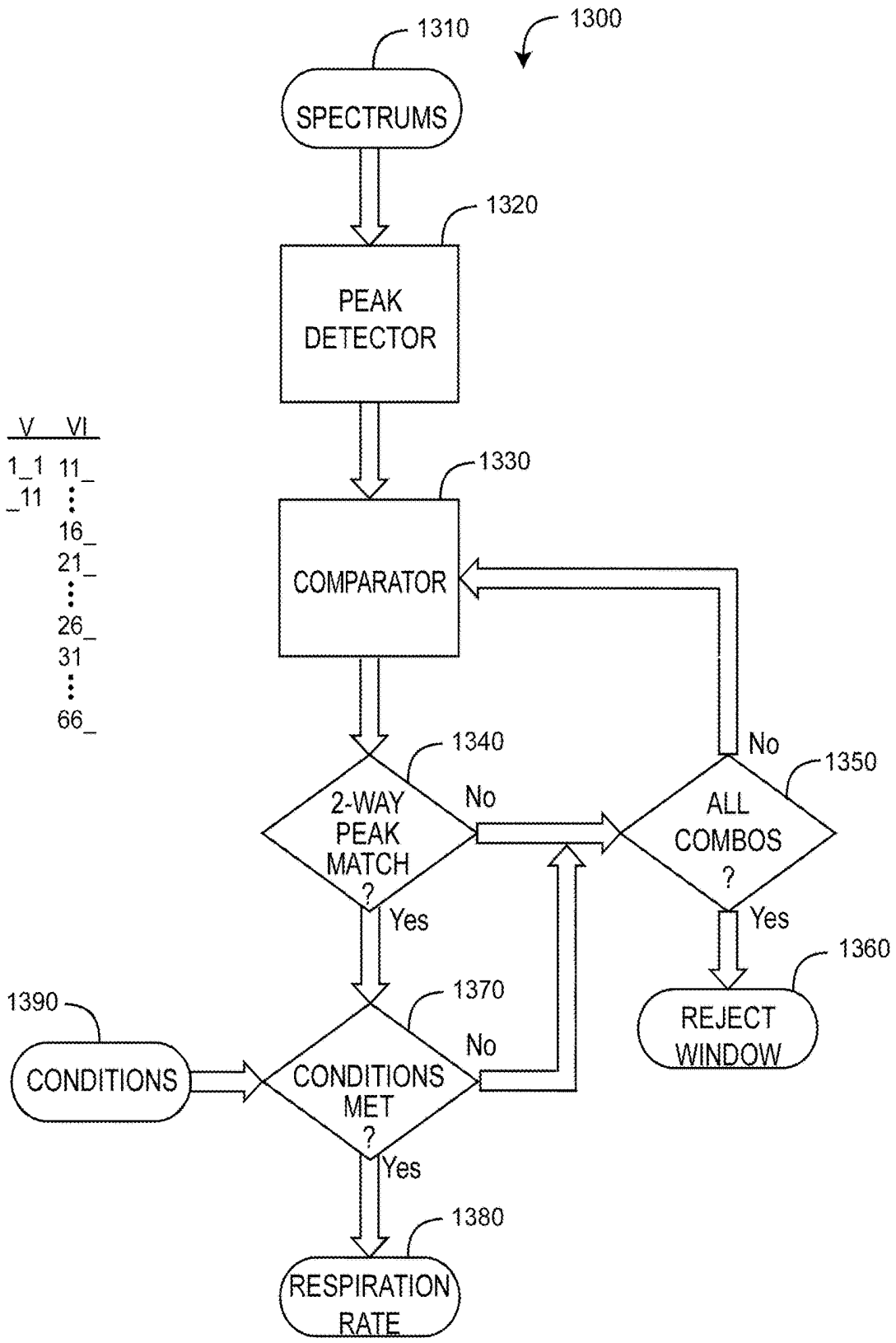

FIG. 13

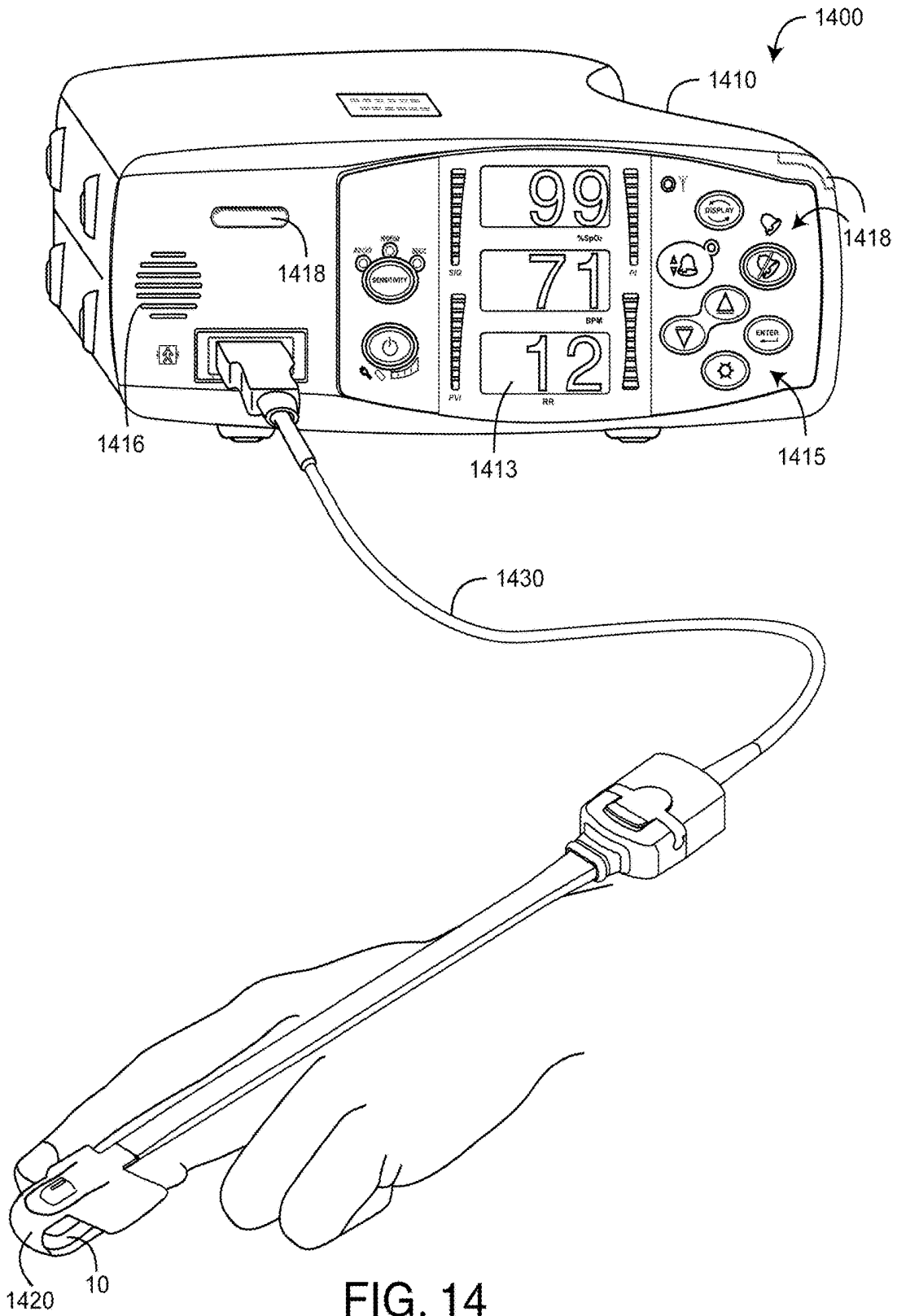

FIG. 14

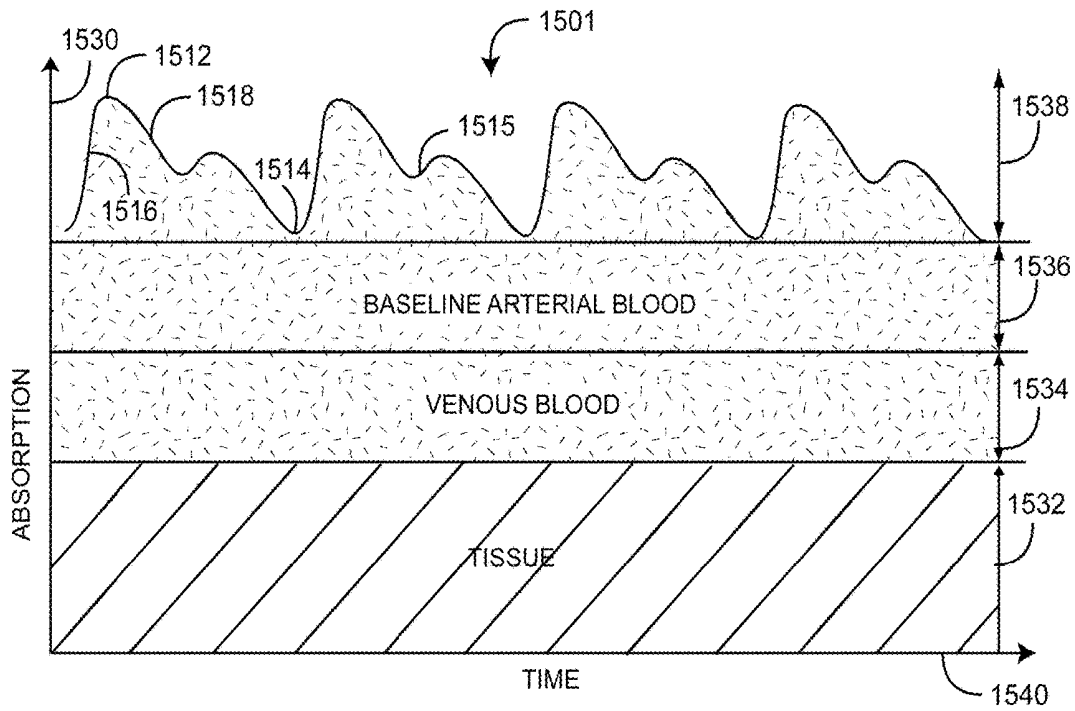

FIG. 15A

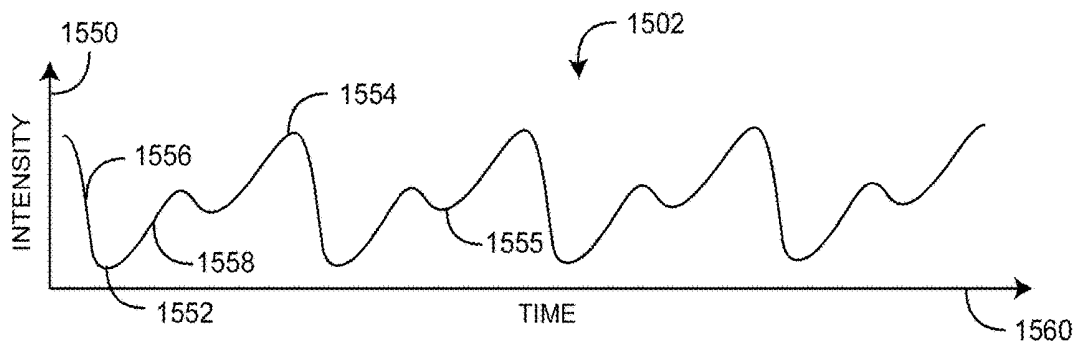

FIG. 15B

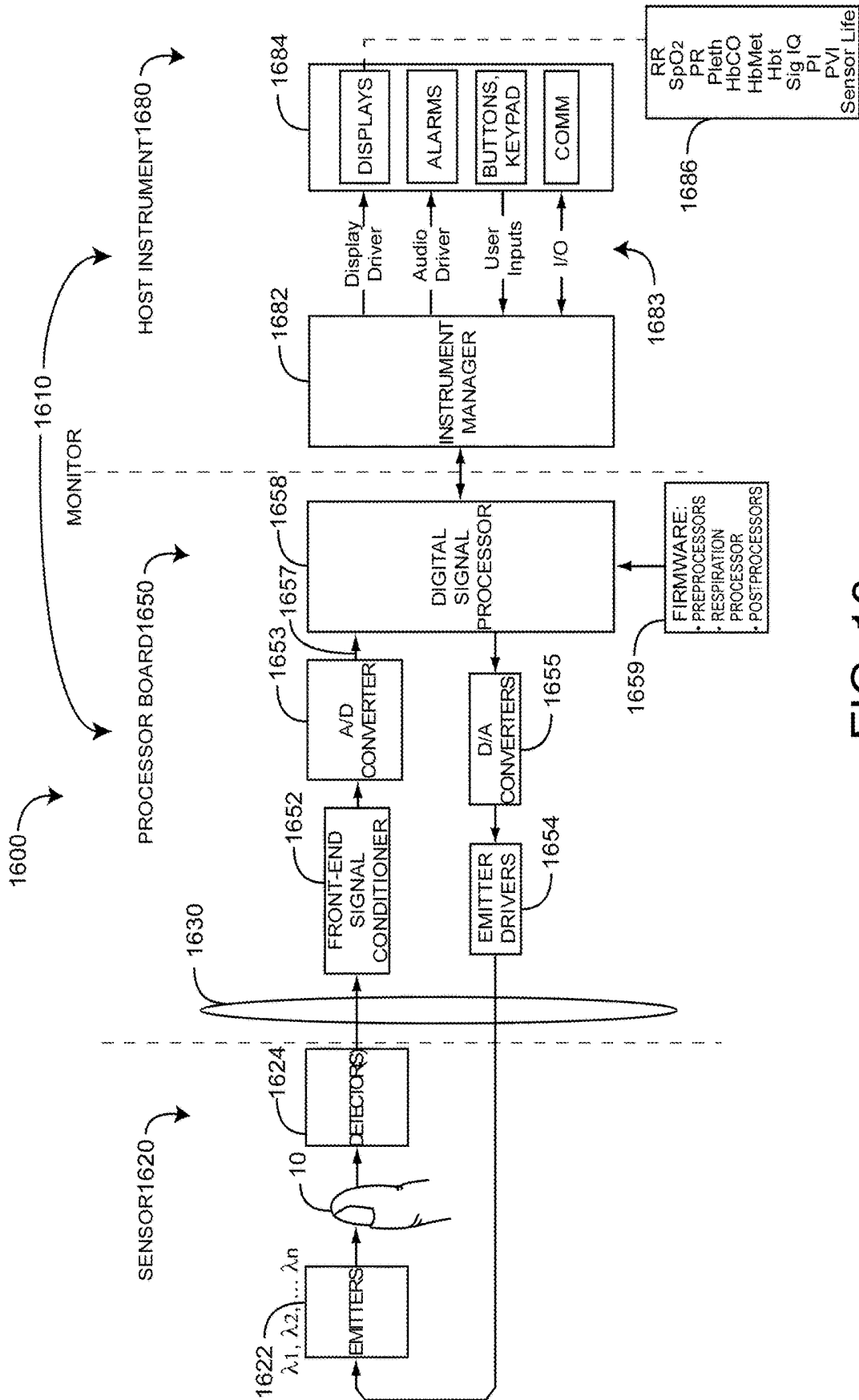

FIG. 16

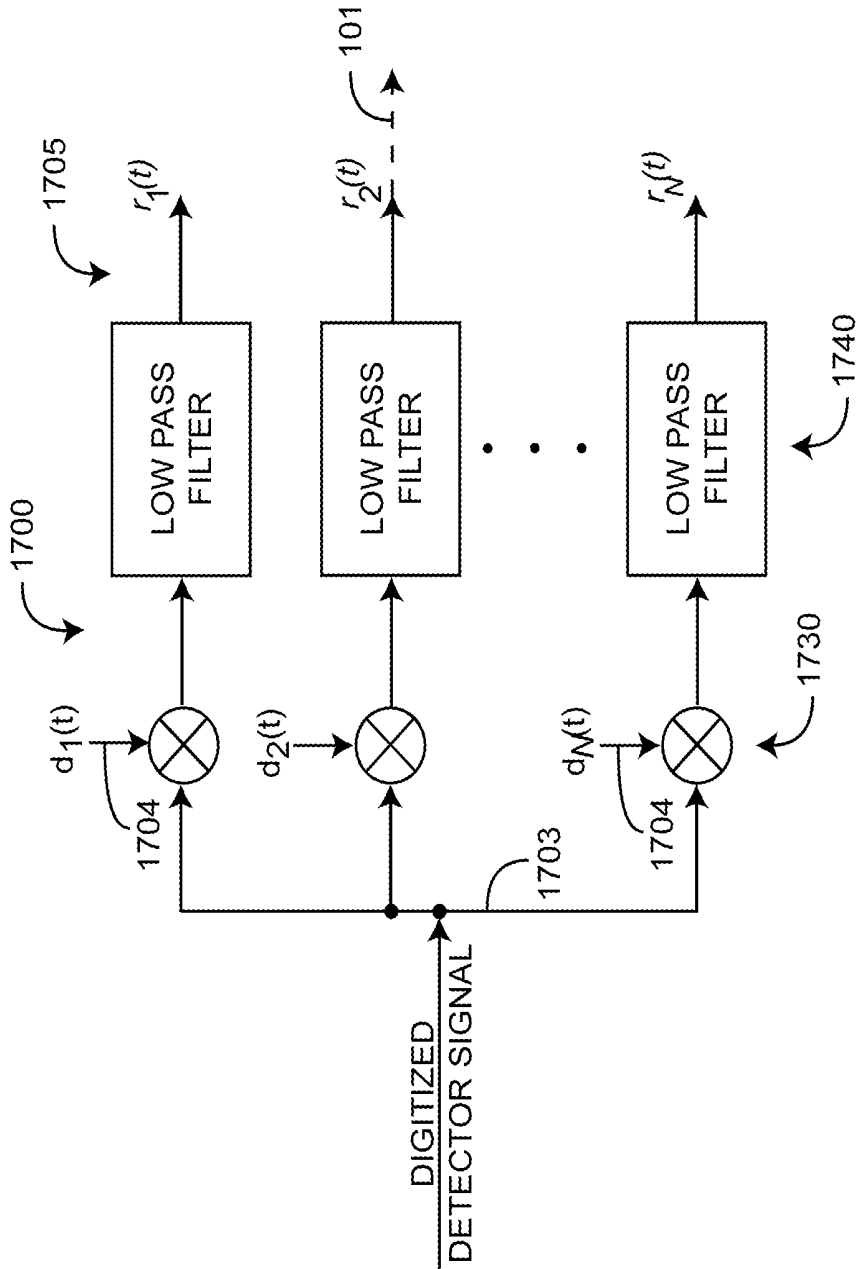

FIG. 17

PLETHYSMOGRAPHIC RESPIRATION RATE DETECTION

PRIORITY CLAIM TO RELATED PROVISIONAL APPLICATIONS

[0001] The present application is a continuation of U.S. patent application Ser. No. 15/095,912, filed Apr. 11, 2016, titled Plethysmographic Respiration Rate Detection, which is a divisional of U.S. patent application Ser. No. 13/076,423, filed Mar. 30, 2011, titled Plethysmographic Respiration Processor, which claims priority benefit under 35 U.S.C. § 119(e) to U.S. Provisional Patent Application No. 61/319,256, filed Mar. 30, 2010, titled Plethysmographic Respiration Processor and U.S. Provisional Patent Application No. 61/364,141, filed Jul. 14, 2010, titled Plethysmographic Respiration Detector; all of the above-cited patent applications are hereby incorporated by reference herein.

BACKGROUND OF THE INVENTION

[0002] Pulse oximetry is a widely accepted noninvasive procedure for measuring the oxygen saturation level of arterial blood, an indicator of a person's oxygen supply. A typical pulse oximetry system utilizes an optical sensor clipped onto a fingertip to measure the relative volume of oxygenated hemoglobin in pulsatile arterial blood flowing within the fingertip. Oxygen saturation (SpO_2), pulse rate and a plethysmograph waveform, which is a visualization of pulsatile blood flow over time, are displayed on a monitor accordingly.

[0003] Conventional pulse oximetry assumes that arterial blood is the only pulsatile blood flow in the measurement site. During patient motion, venous blood also moves, which causes errors in conventional pulse oximetry. Advanced pulse oximetry processes the venous blood signal so as to report true arterial oxygen saturation and pulse rate under conditions of patient movement. Advanced pulse oximetry also functions under conditions of low perfusion (small signal amplitude), intense ambient light (artificial or sunlight) and electrosurgical instrument interference, which are scenarios where conventional pulse oximetry tends to fail.

[0004] Advanced pulse oximetry is described in at least U.S. Pat. Nos. 6,770,028; 6,658,276; 6,157,850; 6,002,952; 5,769,785 and 5,758,644, which are assigned to Masimo Corporation ("Masimo") of Irvine, Calif. and are incorporated by reference herein. Corresponding low noise optical sensors are disclosed in at least U.S. Pat. Nos. 6,985,764; 6,813,511; 6,792,300; 6,256,523; 6,088,607; 5,782,757 and 5,638,818, which are also assigned to Masimo and are also incorporated by reference herein. Advanced pulse oximetry systems including Masimo SET® low noise optical sensors and read through motion pulse oximetry monitors for measuring SO_2 , pulse rate (PR) and perfusion index (PI) are available from Masimo. Optical sensors include any of Masimo LNOP®, LNCS®, Soffouch™ and Blue™ adhesive or reusable sensors. Pulse oximetry monitors include any of Masimo Rad-8®, Rad-5®, Rad®-5v or SatShare® monitors.

[0005] Advanced blood parameter measurement systems are described in at least U.S. Pat. No. 7,647,083, filed Mar. 1, 2006, titled Multiple Wavelength Sensor Equalization; U.S. patent application Ser. No. 11/367,036, filed Mar. 1, 2006, titled Configurable Physiological Measurement System; U.S. patent application Ser. No. 11/367,034, filed Mar.

1, 2006, titled Physiological Parameter Confidence Measure and U.S. patent application Ser. No. 11/366,208, filed Mar. 1, 2006, titled Noninvasive Multi-Parameter Patient Monitor, all assigned to Masimo Laboratories, Irvine, Calif. (Masimo Labs) and all incorporated by reference herein. Advanced blood parameter measurement systems include Masimo Rainbow® SET, which provides measurements in addition to SO_2 , such as total hemoglobin ($SpHb^{TM}$), oxygen content ($SpOCT^{TM}$), methemoglobin ($SpMet^{®}$), carboxyhemoglobin ($SpCO^{®}$) and PVI®. Advanced blood parameter sensors include Masimo Rainbow® adhesive, ReSposable™ and reusable sensors. Advanced blood parameter monitors include Masimo Radical-7™, Rad-87™ and Rad-57™ monitors, all available from Masimo. Such advanced pulse oximeters, low noise sensors and advanced blood parameter systems have gained rapid acceptance in a wide variety of medical applications, including surgical wards, intensive care and neonatal units, general wards, home care, physical training, and virtually all types of monitoring scenarios.

SUMMARY OF THE INVENTION

[0006] Advantageously, a plethysmographic respiration processor provides respiration rate readings based upon optical properties of pulsatile blood flow. The respiration rate so derived may be used alone or combined with respiration rate derived by various other means including, but not limited to, microphones or other acoustic sensors located to respond to various body sounds; humidity sensors located to respond to inhalation/exhalation moisture; thermistors and photodiodes located to respond to inhalation/exhalation air temperature; capacitance sensors located to respond to inhalation/exhalation air pressure; and venturi effect sensors located to respond to inhalation/exhalation air flow. In a particularly advantageous embodiment, a plethysmographic respiration detector is used in conjunction with an acoustic monitor or combined blood parameter and acoustic monitor, such as a Masimo Rainbow® SET platform and an acoustic respiration rate (RRa™) sensor available from Masimo, so as to improve the accuracy of, robustness of, or otherwise supplement acoustic-derived respiration rate measurements or other acoustic-derived respiration parameters.

[0007] One aspect of a plethysmographic respiration processor is responsive to respiration affecting blood volume and a corresponding detected intensity waveform measured with an optical sensor at a blood perfused peripheral tissue site so as to provide a measurement of respiration rate. The plethysmographic respiration detector comprises a preprocessor, processors and decision logic. The preprocessor identifies a windowed pleth corresponding to a physiologically acceptable series of plethysmograph waveform pulses. The processors derive various spectrums of the windowed pleth. Each of the processors is configured so that its corresponding spectrum is particularly responsive to a specific respiratory effect on the windowed pleth. The decision logic determines a respiration rate based upon matching features of at least two of the spectrums.

[0008] In various embodiments, the processors comprise a baseline processor that inputs the windowed pleth and outputs a "baseline" spectrum. The baseline processor has a first signal conditioner and a first frequency transform. The first signal conditioner generates a first conditioned pleth from the windowed pleth. The first frequency transform inputs the first conditioned pleth and generates the baseline spectrum.

[0009] The processors further comprise an amplitude modulation (AM) processor that inputs the windowed pleth and outputs an “AM” spectrum. The AM processor has a second signal conditioner that generates a second conditioned pleth from the windowed pleth. A demodulator AM demodulates the second conditioned pleth to generate a demodulated pleth. A second frequency transform inputs the demodulated pleth and generates the AM spectrum.

[0010] The processors further comprise a shape modulation (SM) processor that inputs the windowed pleth and outputs a “SM” spectrum. The SM processor has a third signal conditioner that generates a third conditioned pleth from the windowed pleth. A feature extractor generates a modulated metric from the third conditioned pleth. A third frequency transform generates the SM spectrum from the modulated metric.

[0011] The decision logic has a peak detector, a comparator and a respiration rate output. The peak detector operates on at least two of the baseline spectrum, the AM spectrum and the SM spectrum so as to determine local maximums. The comparator determines if there are any local maximums from the at least two of the spectrums that occur at matching frequencies within a predetermined tolerance. A respiration rate output is generated if the comparator finds at least a two-way match. A smoother operates on multiple respiration rate outputs derived over a sliding series of the windowed pleths so as to derive a smoothed respiration rate output. A tested condition rejects the respiration rate output if it differs from the smoothed respiration rate output by more than a predetermined amount.

[0012] Another aspect of a respiration rate processor is inputting a plethysmograph waveform, determining a baseline spectrum responsive to a respiratory-induced baseline shift of the plethysmograph waveform, determining an amplitude modulation (AM) spectrum responsive to a respiratory-induced amplitude modulation of the plethysmograph waveform, determining a shape modulation (SM) spectrum responsive to a respiratory-induced shape modulation of the plethysmograph waveform, and matching at least two of the baseline, AM and SM spectrums so as to derive a respiration rate. In an embodiment, determining a baseline spectrum comprises frequency transforming the plethysmograph waveform. In an embodiment, determining an AM spectrum comprises demodulating the plethysmograph waveform so as to generate a demodulated pleth; and frequency transforming the demodulated pleth. In an embodiment, determining a SM spectrum comprises feature extracting the plethysmograph waveform so as to generate a modulated metric and frequency transforming the modulated metric.

[0013] In various other embodiments, matching comprises detecting peaks in at least two of the spectrums, comparing the detected peaks so as to find one peak from each of the at least two spectrums occurring at a particular frequency and outputting the particular frequency as the respiration rate. Windowed pleths are defined by a sliding window of acceptable portions of the plethysmograph waveform. The respiration rate output is smoothed based upon a median respiration rate calculated over multiple ones of the windowed pleths. The particular frequency is rejected if it is not within a predetermined difference of the smoothed respiration rate.

[0014] A further aspect of a respiration rate processor is a baseline processor, an AM processor, a SM processor and decision logic. The baseline processor identifies a respira-

tion-induced baseline shift in a plethysmograph waveform. The AM processor identifies a respiration-induced amplitude modulation of the plethysmograph waveform. The SM processor identifies a respiration-induced shape modulation of the plethysmograph waveform. The decision logic compares the respiration-induced baseline shift, amplitude modulation and shape modulation so as to derive a respiration rate.

[0015] In various embodiments, the baseline processor generates a baseline spectrum from a first frequency transform of the plethysmograph waveform. The AM processor generates an AM spectrum from a second frequency transform of demodulated plethysmograph waveform. The SM processor generates an SM spectrum from a third frequency transform of a modulated metric extracted from the plethysmograph waveform. Decision logic has a peak detector and a comparator. The peak detector determines local maximums in each of the baseline spectrum, AM spectrum and SM spectrum. In an embodiment, the comparator determines a three-way match in the frequency of the local maximums in the spectrums. In an embodiment, the comparator determines a two-way match in the frequency of the local maximums in the spectrums, and a condition for accepting the two-way match compares a respiration rate determined by the two-way match to a smoothed respiration rate.

[0016] A further aspect of a plethysmographic respiration processor is responsive to respiratory modulation of a blood volume waveform or corresponding detected intensity waveform measured with an optical sensor at a blood perfused peripheral tissue site so as to provide a measurement of a respiration parameter. A demodulator processes a sensor signal so as to generate a plethysmograph waveform. A pulse processor identifies candidate pulses from the plethysmograph waveform. A pulse modeler identifies physiologically acceptable ones of the candidate pulses. The plethysmographic respiration processor has a feature extractor, a normalizer and a feature analyzer. The feature extractor processes the acceptable pulses so as to calculate pulse features. The normalizer compares the pulse features so as to calculate a pulse parameter. The feature analyzer calculates a respiration parameter from the pulse parameter.

[0017] In various embodiments, the pulse features comprise a difference (E) between an acceptable pulse and a triangular pulse estimate; the pulse features comprise an area (A) under a triangular pulse; or the pulse features are calculated with respect to a diastolic (d) portion of an acceptable pulse and a corresponding diastolic portion of a triangular pulse. In various embodiments, the normalizer compares a diastolic difference (Ed) with a diastolic area (Ad) or the normalizer calculates Ed/Ad. In an embodiment, the feature analyzer determines the frequency spectrum of Ed/Ad so as to determine a respiration rate.

[0018] Yet another aspect of a plethysmographic respiration processor detects a tissue site response to optical radiation having a plurality of wavelengths, demodulates the response according to wavelength so as to generate a corresponding plurality of plethysmograph waveforms, identifies acceptable pulses from at least one of the waveforms and calculates a respiration parameter from the acceptable pulses. To calculate a respiration parameter, in various embodiments the processor estimates an acceptable pulse with a triangular pulse and determines a systolic portion and a diastolic portion of the acceptable pulse and the triangular pulse; compares the triangular to the acceptable pulse so as

to define pulse features; normalizes the pulse features according to the systolic and diastolic portions so as to generate a pulse parameter; or analyzes the pulse parameter to derive a respiration parameter. The comparing may comprise differencing the acceptable pulse and the triangular pulse over the diastolic portion. The analyzing may comprise transforming the pulse parameter to a frequency parameter and outputting a respiration rate according to a maximum of the frequency parameter.

[0019] Additional aspects of plethysmographic respiration processor has a pulse input having physiologically acceptable pleth pulses derived from a plethysmograph waveform. A feature extractor extracts pulse features from the pulse input. The pulse features are modulated by respiration. A normalizer calculates a pulse parameter from the relative magnitude of a first one of the pulse features compared with a second one of the pulse features. A feature analyzer calculates a respiration parameter from the pulse parameter.

[0020] In various embodiments, the feature extractor may calculate a difference between a triangular pulse estimate and a corresponding pleth pulse. The feature may also calculate an area under a portion of the triangular pulses. The processor may differentiate between a systolic pulse feature and a diastolic pulse feature. The feature extractor may calculate an apex angle of the slope portion of a triangular pulse estimate. The feature analyzer may perform a frequency transform to extract a respiration rate from the pulse parameter.

BRIEF DESCRIPTION OF THE DRAWINGS

[0021] FIG. 1 is a block diagram of a plethysmographic respiration processor embodiment;

[0022] FIGS. 2A-B are a block diagram of a pre-processor embodiment and a time illustration of a sliding window, respectively;

[0023] FIGS. 3A-C are a block diagram of a baseline processor, an intensity versus time graph of a baseline modulated pleth, and a baseline frequency spectrum, respectively;

[0024] FIGS. 4A-D are a block diagram of an AM processor, an intensity versus time graph of an AM pleth, and AM pleth frequency spectrum and a demodulated pleth frequency spectrum, respectively;

[0025] FIGS. 5A-D are a block diagram of an SM processor, an intensity versus time graph of an SM pleth, and graph of a shape metric versus time; and a shape metric frequency spectrum, respectively;

[0026] FIGS. 6A-B are intensity versus time graphs of a shape modulated pulse illustrating area-based shape metrics;

[0027] FIGS. 7A-B are intensity versus time graphs of a shape modulated pulse illustrating arc-length shape metrics;

[0028] FIG. 8A-D are a block diagram of an FM processor, an intensity versus time graph of an FM pleth, and graph of a dicrotic-notch based FM metric versus time; and a FM metric frequency spectrum, respectively;

[0029] FIG. 9 is a block diagram of a pre-processor embodiment;

[0030] FIG. 10 is a block diagram of a plethysmographic respiration processor embodiment;

[0031] FIGS. 11A-D are a spectrum of a combined baseline shifted and AM modulated pleth; a spectrum of a demodulated baseline shifted and AM modulated pleth; a SM spectrum; and a non-idealized spectrum, respectively;

[0032] FIG. 12 is a decision logic flowchart for advantageously deriving a robust value for respiration rate based upon a baseline, an AM and a SM processor operating on an acceptable window of pleths; and

[0033] FIG. 13 is a decision logic flowchart for advantageously deriving a robust value for respiration rate based upon a baseline, an AM and a high pass filtered (HPF) SM processor operating on an acceptable window of pleths.

[0034] FIG. 14 is a perspective view of a non-invasive physiological parameter measurement system having a monitor and a corresponding optical sensor and incorporating a plethysmographic respiration processor;

[0035] FIGS. 15A-B are graphs of light absorption profiles for pulsatile blood perfused tissue and surrounding tissue and an optical sensor detected light intensity, respectively;

[0036] FIG. 16 is block diagram of a non-invasive physiological parameter measurement system having a monitor and a corresponding optical sensor and incorporating a plethysmographic respiration processor; and

[0037] FIG. 17 is a block diagram of a modulated plethysmograph demodulator.

DETAILED DESCRIPTION OF THE PREFERRED EMBODIMENTS

[0038] FIG. 1 illustrates a plethysmographic respiration processor 100 embodiment having a plethysmograph waveform (pleth) input 101 and a respiration rate (RR) output 104. The pleth respiration processor 100 includes a pre-processor 200, one or more pleth processors 120 and a post processor 130. The pleth 101 is derived from an optical sensor attached to a tissue site, which is in communications with a pulse oximeter or blood parameter monitor, as described with respect to FIGS. 14-17, below. The pre-processor 200 derives acceptable pleths 112, as described in detail with respect to FIGS. 2A-B, below. The pleth processor(s) 120 each operate on acceptable pleths 112 so as to generate respiration-rated parameters 102 responsive to a person's respiration. The pleth processors 120 may operate in the time domain, the frequency domain or a mix of time or frequency domains. Pleth processors 120 are described in detail with respect to FIGS. 3-8, below. The post-processor 130 resolves or otherwise verifies the respiration-related parameters 102 so as to derive a respiration rate and, perhaps, averages, smoothes or otherwise filters that respiration rate so as to generate the respiration rate (RR) 104 output. Advantageously, this optical sensor derived RR may be used to derive a less intrusive measure of respiration rate or used in combination with acoustic, mechanical, electrical, temperature or other sensors and monitors so as to determine a more accurate or robust measure of respiration rate. Although described herein as deriving a respiration rate, a plethysmographic respiration processor 100 output may be similarly expressed as a respiration or a breathing frequency or interval, among others.

[0039] FIGS. 2A-B illustrate a pre-processor 200 having a pleth 101 input and generating a conditioned pleth 112, as described below. The pre-processor 200 has a candidate pulse processor 220, a pulse modeler 230, a sliding window 240, a pleth windower 250 and a signal conditioner 260. A single pleth channel is selected from a multiple demodulated pleths 1705 (FIG. 17) as a representative pleth 101 input. In an embodiment, the representative pleth channel corresponds to the IR wavelength channel of a (two wavelength) pulse oximeter.

[0040] As shown in FIG. 2A, the pleth **101** is fed into a candidate pulse processor **220** that removes noise and artifacts and identifies the start and end of pulses that conform to various tests of physiological acceptability. In an embodiment, the candidate pulse processor **220** has curvature, low-pass filter and edge finder components that remove waveform features that do not correspond to the steep inflow phase during ventricular systole or the longer outflow phase during diastole, including the characteristic dichrotic notch and miscellaneous waveform curvature changes. Accordingly, the candidate pulse processor **220** identifies “edges” within an input waveform segment that connect a peak and subsequent valley of a pleth pulse. The candidate pulse processor **220** also has delta T, zero crossing, amplitude threshold and slope checks so as to eliminate certain of the edges that were identified by the curvature, filter and edge finder components that do not meet certain conditions. The delta T discards all the edges that are either too slow or too quick to be physiological. The zero crossing check eliminates all edges that do not cross the zero line, such as small bumps that are not peaks or valleys. The amplitude threshold check removes larger “bumps” than the zero crossing check, such as dicrotic notches. The slope check is based on the observation that in a physiological pulse, the ventricular contraction, i.e. descending pulse portion, is steeper than any subsequent trend in the ascending pulse portion. The pulse finder transforms the edges remaining after the various edge checks into candidate pulses **222**, which are fed into the pulse modeler **230**.

[0041] Also shown in FIG. 2A, the pulse modeler **230** takes the candidate pulses **222** and identifies which of these are acceptable pulses **232**, which satisfy an internal model for a physiological plethysmographic waveform. Although the candidate pulse processor **220** performs a series of checks on edges, the pulse modeler **230** performs a series of checks on pulse features. The first component of the pulse modeler calculates relevant pulse features. The remainder of the pulse modeler checks these pulse features to identify physiologically acceptable features. The pulse features component extracts three items of information about the input candidate pulses that are needed for downstream processing by the other components of the pulse modeler including pulse starting point, period and signal strength. The downstream components include a max BPM check, a stick model check, an angle check, a ratio check and a signal strength check. The maximum beats-per-minute (max BPM) check discards pulses having a period that is below a minimum number of samples. The stick model check discards pulses where the corresponding waveform does not fit a stick model. The angle check is based on computing the angle of a normalized slope for the ascending portion of a pulse so as to discard pulses that are extremely asymmetric. The ratio check removes pulses in which the ratio between the duration of the ascending pulse portion and the duration of the descending pulse portion is less than a certain threshold. The signal strength check assigns a confidence value to each pulse, based on its signal strength, and low confidence pulses are discarded. A pulse processor **220** and a pulse modeler **230** are described in U.S. Pat. No. 6,463,311 titled Plethysmograph Pulse Recognition Processor, issued Oct. 8, 2002, assigned to Masimo Corporation and incorporated by reference herein.

[0042] Further shown in FIGS. 2A-B, the sliding window **240** defines a series of fixed-time-length (T) samples (“win-

dows”) of pleth, where each window **242** is shifted from the previous window by a fixed time interval (Δt) **244**. In an embodiment, each window is $T=2125$ samples (34 sec) in length at 16 msec per sample (62.5 Hz sample rate), where successive windows are shifted by $\Delta t=2$ sec. Each window is either accepted **242** or rejected **248** as designated by an acceptable window **242** output. The pleth windower **250** utilizes the acceptable windows **242** designation to accept a corresponding section of the “raw” pleth **101** input and generate a windowed (raw) pleth **252** output. That is, the pre-processor **200** advantageously allows downstream processing to operate directly on the demodulated pleth while discarding those raw pleth sections that are deemed unacceptable, based upon various pleth models and checks as described above. In an embodiment, the signal conditioner **260** demeans/detrends and bandpass filters the windowed pleth **252** to generate a conditioned pleth **112** output. In an embodiment, the bandpass filter is an IIR filter having a 12-240 bpm (beats per minute) passband. In another embodiment described below with respect to FIG. 9, below, a pre-processor **200** generates windowed features from acceptable pulses derived from the pleth **101** input.

[0043] FIGS. 3A-B illustrate a baseline processor **300** that derives a “baseline” spectrum F_b **302** responsive to a respiration-induced baseline shift in a pleth. As shown in FIG. 3A, the baseline processor **300** has a conditioned pleth **301** input and generates a corresponding baseline spectrum F_b **302**. As shown in FIG. 3B, the conditioned pleth **301** has a pleth period **381** inversely related to pulse rate (PR). Under certain conditions, an individual’s respiration induces a cyclical shift in the pleth baseline **382**. The cyclical shift period **383** is inversely related to respiration rate (RR). As shown in FIG. 3C, a frequency spectrum **302** of the baseline-shifted pleth **301** includes a relatively large pulse rate (PR) peak **392** and a relatively small respiration rate (RR) peak **391**.

[0044] In other embodiments, a baseline processor **300** employs a time domain calculation of the conditioned pleth **301** that determines the period **383** of a cyclical baseline shift and hence respiration rate. Such a time domain calculation may be based upon envelope detection of the conditioned pleths **301**, such as a curve-fit to the peaks (or valleys) of the pleth pulses. Measurements of a cyclical variation in a plethysmograph baseline are described in U.S. patent application Ser. No. 11/221,411 titled Noninvasive Hypovolemia Monitor, filed Sep. 6, 2005 and published as US 2006/0058691 A1, assigned to Masimo and incorporated by reference herein.

[0045] FIGS. 4A-B illustrate an AM processor **400** that derives an “AM” spectrum F_{am} **402** responsive to a respiration-induced amplitude modulation of the pleth. As shown in FIG. 4A, the AM processor **400** has a conditioned pleth **401** input and generates a corresponding AM spectrum F_{am} **402** that is responsive to a demodulated pleth **422**. In an embodiment, the demodulator **420** squares, low pass filters (LPF) and square-roots the conditioned pleth **401** to generate a demodulated pleth **422**. In an embodiment, the frequency transformation **430** utilizes a Hamming window, a chirp-Z FFT algorithm and a magnitude calculation so as to generate an AM spectrum **402** for the demodulated pleth **422**.

[0046] As shown in FIG. 4B, a pleth **401** has a pleth period **471** inversely related to pulse rate (PR). Under certain conditions, an individual’s respiration amplitude modulates (AM) **472** the plethysmograph **401**. In particular, the modu-

lation period **473** is inversely related to respiration rate (RR). As shown in FIG. 4C, a spectrum **480** of the pleth **401** includes a pulse rate (PR) peak **481** and respiration sidebands **482**, **483** displaced by RR on either side of the PR peak **481**. As shown in FIG. 4D a spectrum **402** of the demodulated pleth **422** includes a DC peak **491** resulting from the demodulated pulse rate “carrier” translated to DC and a respiration rate (RR) peak **492** resulting from the demodulated sidebands **482**, **483**.

[0047] An AM processor **400** is described above as demodulating **420** a conditioned pleth **401**. In other embodiments, a time domain calculation of the conditioned pleth **401** determines the respiration modulation period **473** and hence the respiration rate. That time domain calculation may be based upon envelope detection of the conditioned pleth **401**, such as a curve-fit to the peaks (or valleys) of the plethysmograph or, alternatively, the peak-to-peak variation. Measurements of variation in a plethysmograph envelope are described in U.S. patent application Ser. No. 11/952,940 titled Plethysmograph Variability Processor, filed Dec. 7, 2007 and published as US 2008/0188760 A1, assigned to Masimo and incorporated by reference herein.

[0048] FIGS. 5A-D illustrate a shape modulation (SM) processor **500** that derives an “SM” spectrum F_s **502** responsive to a respiration-induced shape modulation of the pleth. As shown in FIG. 5A, the SM processor **500** has a conditioned pleth **501** input and generates a corresponding SM spectrum F_s **502**. In an embodiment, the SM processor **500** includes a feature extractor **520**, a high pass filter (HPF) **530** and a frequency transform **540**. In another embodiment, the SM processor includes the feature extractor **520** and a frequency transform **540**, but excludes the high pass filter **530**. The feature extractor **520** generates a shape-based modulated metric **522**, such as E/A described below. In an embodiment, the HPF **530** is a time domain difference filter that calculates $Y_{n+1} - Y_n$ so as to remove an erroneous first (low frequency) peak in the SM spectrum F_s **502**. In an embodiment, the frequency transformation **540** utilizes a Hamming window, a chirp-Z FFT algorithm and a magnitude calculation so as to generate the SM spectrum **502** for each windowed conditioned pleth **501**.

[0049] As shown in FIG. 5B, a pleth **501** has a pleth period **571** inversely related to pulse rate (PR). Under some circumstances, an individual’s respiration modulates the shape of each pleth pulse. This modulation may be described in terms of a predefined pleth feature or “shape metric.” In an advantageous embodiment, a shape metric is defined by a difference or “error” E **572** between the diastolic portion of a pleth pulse and its corresponding triangular pulse approximation, normalized by the area A **573** under the triangular pulse approximation.

[0050] As shown in FIG. 5C, a respiration-modulated shape metric **522** has a cyclical period **581** inversely related to respiration rate (RR). As shown in FIG. 5D, a spectrum **502** of the modulated shape metric **522** includes a respiration rate (RR) peak **591**.

[0051] A SM processor **500** is described above as based upon a normalized diastolic error metric (E/A). In other embodiments, shape metrics may be based upon other pulse features such as a diastolic area, error or angle normalized by the corresponding systolic area, error or angle (Ad/As, Ed/Es, $\theta d/\theta s$), or shape metrics may be related to the arc length of the diastolic and/or systolic portions of a pleth

pulse, to name a few. These and other pulse shapes and features responsive to respiration are also contemplated herein.

[0052] FIGS. 6A-B further illustrates pulse shape features that are derived by a feature extractor **520** (FIG. 5A) embodiment. Acceptable pleth pulses **610** are generated by the pre-processor **200** (FIG. 2A), as described above. For convenience of illustration, the inverse of an “intensity” pulse is shown, as described with respect to FIGS. 15A-B, below. The pleth pulse **610** has a peak Y at a time W and corresponding valleys at times X and Z. The peak and valleys define a triangular pulse **620** XYZ that approximates the pleth pulse **610**. Further, the time line WY corresponding to the peak Y divides the pleth pulse **610** into a systolic portion **630** and a diastolic portion **640**.

[0053] As shown in FIG. 6A, a systolic error E_s **631** is defined as the total area between the pleth pulse **610** and the approximate triangular pulse **620** within the systolic portion **630**. A diastolic error E_d **641** is defined as the total area between the pleth pulse **610** and the triangular pulse **620** within the diastolic portion **640**.

[0054] As shown in FIG. 6B, a systolic area A_s **632** is defined as the total area under the triangular pulse **620** within the systolic portion **630**. A diastolic area A_d **642** is defined as the total area under the triangular pulse **620** within the diastolic portion **640**. A systolic angle θ_s **633** is defined as the angle XYW defined by the triangular pulse within the systolic portion **630**. A diastolic angle θ_d **643** is defined as the angle ZYW defined by the triangular pulse within the diastolic portion **640**.

[0055] Based upon the above-described pulse feature definitions, normalized pulse features may be defined. These may include normalized diastolic pulse features, such as E_d/A_d , corresponding to the diastolic triangular pulse error normalized by the diastolic triangular pulse area. Other normalized diastolic pulse features may include a diastolic area, error or angle normalized by the corresponding systolic area, error or angle (A_d/A_s , E_d/E_s , $\theta d/\theta s$).

[0056] FIGS. 7A-B illustrate additional pulse shape features. As shown in FIG. 7A, pulse features may be based upon the length of a curve (trace, arc, path or line) portion of a pleth pulse **710**. In particular, a diastolic curve length L_d **745** between the pulse peak Y and valley Z is defined in polar coordinates as:

$$L_d = \int_Y^Z \sqrt{r^2 + \left(\frac{dr}{d\theta}\right)^2} d\theta \quad (\text{EQ. 1})$$

where r is the distance from W (time corresponding to the peak Y) to any point V along the curve **710** and θ is the angle between r and the time axis WZ. L_d **745** may be similarly defined in Cartesian coordinates. A systolic curve length L_s **735** may be defined in similar fashion. A normalized length pulse feature L_d/L_s may be defined accordingly. In other embodiments, pulse features L_d **745** or L_s **735** may be normalized by the diastolic **640** or systolic **630** areas or angles defined with respect to FIG. 6B, above. In various embodiments, pulse features L_d **745** or L_s **735** also may be normalized by pulse height WY, by diastolic WZ or systolic XW pulse widths, by total pulse width XZ or by mathematical combinations of these measures of pulse height and pulse width to name a few.

[0057] As shown in FIG. 7B, pulse shape features may be based upon the curvature of a portion of a pleth pulse 710. In particular, a curvature Λ is defined in pedal coordinates as:

$$\kappa = \frac{1}{r} \frac{dp}{dr} \quad (\text{EQ. 2})$$

where the pedal coordinates of a point V with respect to the pulse 710 and the pedal point W are the radial distance r from W to V and the perpendicular distance p from W to the line t tangent to the pulse 710 at V, as shown. K may be similarly defined in Cartesian or polar coordinates. Total curvature K of a curve segment between points a and b is then

$$K = \int_a^b \kappa(s) ds \quad (\text{EQ. 3})$$

[0058] A diastolic curvature K_d 746 or systolic curvature K_s 736 pulse shape feature may be defined accordingly. In other embodiments, a curvature pulse shape feature may be defined according to the absolute value of the maximum and/or minimum curvature of the pulse 710 or pulse segment 730, 740, or the curvature of a particular feature, such as a dicrotic notch. In other embodiments, pulse shape features K_d 746 or K_s 736 may be normalized by the diastolic 640 or systolic 630 areas or angles defined above with respect to FIGS. 6A-B. In various embodiments, pulse features K_d 746 or K_s 736 also may be normalized by pulse height WY, by diastolic WZ or systolic XW pulse widths, by total pulse width XZ or by mathematical combinations of these measures of pulse height and pulse width to name a few. In other embodiments, various normalized systolic and/or diastolic pulse features may be similarly defined.

[0059] FIG. 8A-D illustrate an FM processor 800 that derives an "FM" spectrum F_{fm} 802 responsive to a respiration-induced frequency modulation of the pleth. As shown in FIG. 8A, the FM processor 800 has a conditioned pleth 112 input and generates a corresponding FM spectrum F_{fm} 802 that is responsive to a demodulated pleth 822. In an embodiment, the demodulator 820 utilizes a metric Δ responsive to the time difference between identifiable epochs of each pleth pulse. In an embodiment, the epochs are based upon a dicrotic notch. In an embodiment, the metric Δ is the time difference between two identifiable portions of a dicrotic notch such as the notch local maximum, local minimum, or mid-point between local maximum and local minimum, to name a few.

[0060] As shown in FIG. 8B, a pleth 801 has a pleth period 871 inversely related to pulse rate (PR). Under certain conditions, an individual's respiration frequency modulates (FM) the plethysmograph 801. In particular, the modulation period 881 (FIG. 8C) is inversely related to respiration rate (RR). FIG. 8C illustrates a respiration-modulated FM metric 822 over time. In particular, an FM metric 822, such as the metric Δ described above, has a cyclical period 881 inversely related to respiration rate (RR). As shown in FIG. 8D, a spectrum 802 of the FM metric 822 includes a respiration rate (RR) peak 891.

[0061] FIG. 9 illustrates another pre-processor 900 embodiment having a pleth 101 input and generating a windowed features 962 output. The pre-processor 900 has a candidate pulse processor 220 and pulse modeler 230 that operate on the pleth 101 input so as to generate an acceptable pulses 232 output, as described with respect to FIG. 2A, above. Further, the pre-processor 900 has a time base standard 940, a feature extractor/normalizer 950, and a windowing/outlier rejecter 960. The time base standard 940 inputs acceptable pulses 941 and outputs resized pulses 942. In particular, the time base standard 940 mathematically re-samples the input pulses 941 so that each pulse has the same number of samples. For example, if a standard pulse has 50 samples and an input pulse 941 has 60 samples, then the input pulse 941 sample interval is made larger by 60/50 or 1.2 times so that the resized input pulse width is 50 samples. Similarly, if an input pulse 941 has 40 samples, then the input pulse 941 sample interval is made smaller by 40/50 or 0.8 times so that the resized input pulse width is 50 samples. A resized input pulse is derived by interpolating the original pulse at re-sampled points. For example, a linear interpolation embodiment is used according to the following

$$y = \left(\frac{y_2 - y_1}{x_2 - x_1} \right) (x - x_1) + y_1 \quad (\text{EQ. 4})$$

where $X_2 - X_1$ is the original sample interval; Y_1 and Y_2 are input pulse 401 values at X_1 and X_2 , respectively; x is a resized sample point between X_1 and X_2 and y is the resized pulse value at x . In other embodiments, the interpolation is a cubic spline or a polynomial interpolation to name a few.

[0062] Also shown in FIG. 9, the feature extractor/normalizer 950 inputs the resized pulses 942 described above and outputs normalized pulse features 952. Pulse features may include one or more of the differences or "errors" E between an acceptable pulse and its corresponding triangular pulse; areas A under the triangular pulse; and apex angles θ of a triangular pulse, to name a few, as described in detail with respect to FIGS. 6-7, above. Pulse features may also distinguish between a steeper-slope portion corresponding to systole S and a shallower-slope portion corresponding to diastole D . Pulse features are normalized by comparing one or more extracted features with one or more other extracted features. In an embodiment, normalized pulse features 952 advantageously include Ed/Ad corresponding to the diastolic triangular pulse error normalized by the diastolic triangular pulse area. Other normalized pulse features 952 may include a diastolic area, error or angle normalized by the corresponding systolic area, error or angle (Ad/As , Ed/Es , $\theta d/\theta s$). These and additional normalized pulse features relating to an acceptable pulse and/or its corresponding triangular pulse are also contemplated herein and described with respect to FIGS. 6-7, above.

[0063] Further shown in FIG. 9, the windowing/outlier rejecter 960 inputs the normalized features 952 and outputs windowed features 962. The windowed features 962, in turn, may be frequency transformed or analyzed in the time domain to determine a respiration modulation of the features, as described above. In particular, windowing 960 defines a sample size (window size) of the normalized features 952. The outlier rejecter 960 calculates a mean or median of the normalized features 952 falling within the

window, defines an acceptable range around the mean or median and rejects normalized features falling outside of that acceptable range.

[0064] Window size may be a function of a respiration rate (RR) 964, a heart rate (HR) 966 or both. In particular, HR 966 corresponds to the input pulse 101 frequency and hence determines the time between samples of the normalized features 952. RR 964 corresponds to the number of feature cycles within a window and hence sets a lower limit on the window size in order to resolve the frequency of those feature cycles.

[0065] Pulse rates may typically vary from a resting rate of 40-60 BPM for athletes to 60-90 BPM for non-athletes. Maximum heart rates are typically defined as 220—age. Hence, pulse rates might typically range from 50 to 200 BPM, which is a 4:1 variation in time between samples (0.3 sec to 1.2 sec). Respiration rates may typically vary between 12-20 breaths per minute for resting adults to 35-45 breaths per minute for exercising adults. Hence RR may typically range from 10-50 breaths per minute, which is a 5:1 variation in the number of respiration cycles per window. Accordingly, the number of pulse feature samples per respiration cycle may have a 20:1 variation.

[0066] Windowing 960 may be fixed or adjustable. Further, successive windows may be overlapping, i.e. a sliding window may be used, or may be adjacent and non-overlapping. A typical window size may range, say, between 15-120 sec. or more. Accordingly, a window size may encompass, say, 20 respiration cycles at 10 breaths per minute over a 120 sec. window to 12 respiration cycles at 50 breaths per minute over a 15 sec. window. In an embodiment, the window size is adaptively adjusted based upon detected RR and PR.

[0067] FIG. 10 illustrates a plethysmographic respiration processor 1000 embodiment having a conditioned plethysmograph waveform (pleth) 112 input and a smoothed respiration rate (RRs) 1005 output. The respiration processor 1000 includes parallel processors 1020, decision logic 1100-1300 and a smoother 1030. The conditioned pleth 112 contains pleth sections corresponding to sliding acceptable windows designated by the pre-processor 200 (FIG. 2A), as described above with respect to FIGS. 2A-B. The parallel processors 1020 each operate on conditioned pleth 112 so as to generate frequency spectrums 1022 responsive to respiration rate. The parallel processors 1020 include a baseline processor 300, an amplitude modulation (AM) processor 400, a high pass filtered (HPF) shape modulation (SM) processor 500 and a SM processor 501. In particular, the baseline processor 300 derives a “baseline” spectrum F_b 302 responsive to a respiration-induced baseline shift in a pleth. The baseline processor 300 is described in detail with respect to FIGS. 3A-C, above. The AM processor 400 derives an “AM” spectrum F_{am} 402 responsive to a respiration-induced amplitude modulation of the pleth. The AM processor 400 is described in detail with respect to FIGS. 4A-D, above. The SM processors 500, 501 derive “SM” spectrums F_s 502, F_s' 504 each responsive to a respiration-induced shape modulation of the pleth. The SM processors 500, 501 are described in detail with respect to FIGS. 5-7, above.

[0068] As described above, the processors 1020 each generate one spectrum 1022 for each sliding window of the conditioned pleth 112. Accordingly, the decision logic 1100-1300 attempts to generate a respiration rate (RR) value for each conditioned pleth 112 window. The decision logic

1100-1300 compares two or more of the spectrums F_b , F_{am} , F_s and F_s' 422 so as to calculate a respiration rate (RR) 1004. If the decision logic 1100-1300 cannot determine a RR 1004 value from the spectrums 1022, the corresponding conditioned pleth window 112, is rejected. A smoother 1030 generates a smoothed respiration rate 1005 calculated over multiple respiration rate 1004 values. In an embodiment, the smoother 1030 determines the median value of RR 1004 corresponding to multiple ones of the conditioned pleth windows 112. In an embodiment, the median value is calculated over five conditioned pleth windows 112. The decision logic 1100-1300 is described in detail with respect to FIGS. 11-13, below.

[0069] FIGS. 11A-C illustrate the output of the baseline processor 300 (FIG. 10), AM processor 400 (FIG. 10) and SM processor 500 (FIG. 10), respectively, assuming that a conditioned pleth 112 (FIG. 10) exhibits each of a baseline shift, an amplitude modulation and a shape modulation due to respiration. As shown in FIG. 11A, in view of both a respiration-induced baseline shift and AM modulation, the windowed pleth spectrum 1110 is a combination of a baseline shift spectrum 302 (FIG. 3C) and an AM spectrum 402 (FIG. 4D). This combination is also the baseline spectrum F_b 302 (FIG. 3A), i.e. the frequency transform of the conditioned pleth 112. Hence, in this example, the baseline spectrum 1110 has two possible local maximums or “peaks” 1115, 1116. One peak is due to respiration shifting the pleth baseline and one peak is due to respiration amplitude modulating the pleth. However, these peaks cannot be distinguished. In particular, if $RR < 0.5 PR$, then peak 1115 is at a frequency corresponding to RR and peak 1116 is at a frequency corresponding to $PR - RR$. Likewise, if $RR > 0.5 PR$, then peak 1115 is at a frequency corresponding to $PR - RR$ and peak 1116 is at a frequency corresponding to RR. That is, “twin” peaks 1115, 1116 occur symmetrically on either side of frequency $\frac{1}{2} PR$, one at frequency RR and one at frequency $PR - RR$, but the peak corresponding to the respiration rate RR cannot be resolved by the baseline processor 302 (FIG. 10) alone.

[0070] As shown in FIG. 11B, in view of both a respiration-induced baseline shift and AM modulation, the AM spectrum F_{am} 402 (FIG. 10) is a combination of the spectrums of FIG. 3C and FIG. 4C after demodulation. Hence, in this example, the AM processor output 402 (FIG. 10) has two possible local maximums or peaks 1125, 1126. One peak is due to demodulating the pleth corresponding to the spectrum of FIG. 4C, resulting in the spectrum of FIG. 4D. The other peak is due to demodulating the pleth corresponding to the spectrum of FIG. 3C, which translates the pleth fundamental 392 (FIG. 3C) at PR to DC and the respiration-related peak 391 (FIG. 3C) to $PR - RR$. As with the peaks described with respect to FIG. 11A, these “twin” peaks 1125, 1126 occur symmetrically on either side of $\frac{1}{2} PR$, but the peak corresponding to the respiration rate RR cannot be resolved by the AM processor 400 (FIG. 10) alone.

[0071] As shown in FIG. 11C, the SM spectrum F_s 502 is unaffected by either a baseline shift or by amplitude modulation. In particular, a respiration-induced baseline shift, which shifts the entire pleth waveform up or down, has negligible effect on the error E 572 (FIG. 5B) or the triangular area A 573 (FIG. 5B). Further, although respiration-induced AM increases or decreases the pleth amplitude, this is accounted for by normalizing the error E by the triangular area A. As such, in view of both a respiration-

induced baseline shift and AM, the SM spectrum F_s 502 is responsive only to shape modulation, as shown in FIG. 5D, i.e. a single local maximum or peak 1135 occurs at the respiration rate.

[0072] As shown in FIGS. 11A-C, ideally respiration rate may be determined by first verifying the existence of twin peaks 1115, 1116 symmetric about 0.5 PR in the baseline spectrum 1110 and twin peaks about 0.5 PR in the AM spectrum 1120. Second, one twin from each spectrum 1110, 1120 is matched with the single peak in the SM spectrum 1130. For example, a match between peaks 1115 (FIG. 11A), 1125 (FIG. 11B) and 1135 (FIG. 11C) would provide a robust indication of RR. However, pleths from various sensors, monitors and patients may yield spectrums with erroneous peaks due to physiological conditions or artifact. Accordingly, various peaks and matching conditions are utilized by the decision logic to determine RR, as described with respect to FIGS. 12-13, below.

[0073] As shown in FIG. 11D, a peak identifying nomenclature 1140 is used in describing decision logic with respect to the baseline spectrum F_b 302 (FIG. 10) and the AM spectrum F_{am} 402 (FIG. 10). The largest peak in a spectrum is designated ① and its twin designated ④. If the largest peak is the first peak, which is sometimes erroneous, then the second largest peak is designated ② and its twin designated ⑤. If the largest peak is the last peak, which is also sometimes erroneous, the second largest peak is designated ③ and its twin designated ⑥.

[0074] FIG. 12 illustrates the decision logic 1200 for advantageously deriving a robust value for respiration rate based upon each of the baseline 300, AM 400 and SM 500 processors (FIG. 10) operating on a conditioned pleth 112 (FIG. 10). The spectrums F_b , F_{am} and F_s from these processors are input 1210 into the decision logic 1200. A peak detector 1220 locates the largest peak ① and its twin ④ from each of F_b 1110 (FIG. 11A) and F_{am} 1120 (FIG. 11B) and the largest peak ① from F_s 1130 (FIG. 11C). The comparator 1230 looks for a three-way match from, say, the largest peak from each of the spectrums. This comparison is denoted 1-1-1, designating the largest peaks from the spectrums F_b - F_{am} - F_s , respectively. If the frequencies of all of these peaks match 1240, within a predetermined error, then that frequency is output as the respiration rate 1250 for that conditioned pleth window 112 (FIG. 10). If there is no match 1240, other combinations 1260, 1266 of peaks of a particular series are compared 1230, such as the largest peak from F_b , the twin to the largest peak from F_{am} and the largest peak from F_s , denoted 1-4-1. Hence, all of the following combinations are denoted the first series of combinations to try, i.e. series I: 1-1-1; 1-4-1; 4-1-1; 4-4-1.

[0075] As shown in FIG. 12, if there are no matches from series I, other series 1270, 1275 having different types of combinations are tried, as explained below. If a particular twin cannot be located, the corresponding series is rejected 1275. If no 3-way matching peaks are found after trying all combinations in each of series I, II, III, IV 1270, then that particular window is rejected 1280 and no respiration rate value is determined that corresponds to that window.

[0076] Series II represents a second set of peak comparisons. In some cases, the largest peak ① from F_b or F_{am} or both may be the first peak, which is often erroneous. As such, comparisons may be made using the second largest peaks ② from F_b and F_{am} and the corresponding twins ⑤. The twins in this series are verified to exist, but not used.

Accordingly, in an embodiment, the largest peaks ① and the second largest peaks ② are compared in the following combinations: 2-1-1; 1-2-1; 2-2-1.

[0077] Series III represents a third set of peak comparisons. In some cases, the largest peak from F_b or F_{am} or both may be the last peak, which is also often erroneous. As such, comparisons may be made using the second largest peaks ③ from F_b and F_{am} and the corresponding twins ⑥. Accordingly, in an embodiment, these peaks are compared in the following combinations: 3-3-1; 6-3-1; 3-6-1; 6-6-1.

[0078] Series IV represents yet another set of peak comparisons. In some cases, the largest peak from F_s is erroneous. Hence, comparisons may be made using the largest peak from F_s' , designated ③, and the largest peak and corresponding twin from F_b and F_{am} , designated ① and ④, as noted above. Accordingly, in an embodiment, these peaks are compared with each other in the following combinations: 4-4-3; 4-1-3; 1-4-3; 1-1-3. In other embodiments, other combinations are possible, for example, the twins to the second largest peaks from F_b and F_{am} , which are designated ⑤, could be used in various combinations with other designated peaks described above. If all combinations fail to yield a three-way match 1240, then that particular window is rejected 1280.

[0079] FIG. 13 illustrates decision logic 1300 for advantageously deriving a robust value for respiration rate based upon a two-way match of the spectrums F_b , F_{am} and F_s (or F_s') from each of the baseline 300, AM 400 and shape 500, 501 processors (FIG. 10) plus an additional condition 1390. In an embodiment, decision logic 1300 is used in the event a respiration rate RR 1004 (FIG. 10) cannot be derived from a three-way match of the spectrums F_b , F_{am} and F_s (or F_s'), as described with respect to FIG. 12, above.

[0080] As shown in FIG. 13, in a series V, the largest peaks from F_b and F_s , denoted 1_1 (without utilizing F_{am}) are compared for a two-way match 1330. If there is a match, an additional condition 1370 must be met. In an embodiment, the condition 1390 is that the matching frequencies of F_b and F_s must be within a predetermined difference of the smoothed respiration rate (RRs) 1005 (FIG. 10). In an embodiment, the predetermined difference is 1 bpm. If so, the matching frequencies are output as the respiration rate RR 1380. If not, the largest peaks from F_{am} and F_s , denoted _11 (without utilizing F_b) are also compared for a match 1330. If there is a match from this comparison and the additional condition 1370 is met, then the matching frequencies are output as the respiration rate RR 1380. If these combinations are compared without a match 1350, then a series VI is utilized.

[0081] Also shown in FIG. 13, in a series VI, the various peaks from F_b and F_{am} , each denote 1-6, are compared for a two-way match 1330. If there is a match, the additional condition 1370 must be met. If all combinations, e.g. 11, 12, 13 . . . 21, 22, 23 . . . 36, 46, 56 are tried without a match or there is a match but the additional condition is not met, the window is rejected 1360. In other embodiments, other peaks are compared 1330 and other conditions 1390 must be met.

[0082] FIG. 14 illustrates a physiological monitoring system 1400 that incorporates a plethysmographic respiration processor 100 (FIG. 1), as described above. The monitoring system 1400 has a monitor 1410, an optical sensor 1420 and an interconnect cable 1430 connecting the monitor 1410 and sensor 1420. The monitoring system 1400 generates physi-

ological parameters that indicate one or more aspects of a person's physical condition, including, advantageously, a plethysmograph-derived respiration rate. The sensor **1420** attaches to a tissue site **10**, such as a fingertip, and is capable of irradiating the tissue site **10** with differing wavelengths of light and detecting the light after attenuation by pulsatile blood flow within the tissue site **10**. The monitor **1410** communicates with the sensor **1420** via the interconnect cable **1430** to receive one or more detected intensity signals and to derive from those intensity signals one or more physiological parameters. The monitor also has a display **1412** for presenting parameter values, including respiration rate (RR). Controls **1415** set alarm limits, processing modes, display formats and more. An audio transducer **1416** provides alarm sounds, pulse beeps and button press feedback to name a few. Indicators **1418** show monitor status. The display **1412** may include readouts, colored lights or graphics generated by LEOs, LCOs or CRTs to name a few and is capable of displaying indicia representative of calculated physiological parameters, including respiration rate, and waveforms, including plethysmographs. The display **1412** is also capable of showing historical or trending data related to one or more of the measured parameters or combinations of the measured parameters. User I/O may include, for example, push buttons **1415** and indicators **1418**. The push buttons may be soft keys with display-indicated functions or dedicated function keys **1415**. Other user I/O (not shown) may include keypads, touch screens, pointing devices, voice recognition devices and the like.

[0083] FIG. 15A illustrates a light absorption waveform **1501** at an illuminated peripheral tissue site corresponding to a pulsatile blood volume at that site. The peripheral tissue site is illuminated by, and the corresponding absorption is (indirectly) measured by, an optical sensor **1420** (FIG. 14), as described above. A y-axis **1530** represents the total amount of light absorbed by the tissue site, with time shown along an x-axis **1540**. The total absorption is represented by layers, including the static absorption layers due to tissue **1532**, venous blood **1534** and a baseline of arterial blood **1536**. Also shown is a variable absorption layer **1538** due to the pulse-added volume of arterial blood that is used to derive a plethysmograph, as described above and further with respect to FIG. 15B, below. This light absorption waveform **1501** varies as a function of the wavelength of the optical sensor emitted light according to the blood constituency. Indeed, it is this wavelength variation that allows a multi-parameter patient monitor to determine blood hemoglobin components and other blood constituents along with respiration rate characteristics, as described above.

[0084] As shown in FIG. 15A, a pulsatile blood volume **1538** is a function of heart stroke volume, pressure gradient, arterial elasticity and peripheral resistance. The ideal pulsatile blood volume waveform displays a broad peripheral flow curve, with a short, steep inflow phase **1516** followed by a 3 to 4 times longer outflow phase **1518**. The inflow phase **1516** is the result of tissue distention by the rapid blood volume inflow during ventricular systole. During the outflow phase **1518**, blood flow continues into the vascular bed during diastole. The end diastolic baseline **1514** indicates the minimum basal tissue perfusion. During the outflow phase **1518** is a dicrotic notch **1515**. Classically, the dicrotic notch **1515** is attributed to closure of the aortic valve at the end of ventricular systole. However, it is also a function of reflection from the periphery of an initial, fast

propagating pressure pulse that occurs upon the opening of the aortic valve preceding the arterial flow wave. Pulsatile blood volume varies with physiological properties such as heart stroke, vessel size, elasticity and vascularization, to name a few. Accordingly, the blood flow waveform shape can vary significantly from individual to individual and between tissue sites.

[0085] FIG. 15B illustrates a plethysmograph waveform **1502** detected by an optical sensor **1420** (FIG. 14). In particular, detected intensity is shown along the y-axis **1550** versus time shown along the x-axis **1560**. The plethysmograph waveform **1502** is a time series of plethysmograph ("pleth") pulses and relates to the time-varying pulsatile blood volume **1538** (FIG. 15A) measured at a particular location on a person, referred to herein as a "tissue site." A tissue site can be a fingertip, ear lobe, toe, nose or forehead to name just a few. A person is used herein as the referenced subject of optical sensor measurements, but other living species also have a measurable pleth and are included within the scope of this disclosure.

[0086] As shown in FIG. 15B, an optical sensor **1420** (FIG. 14) does not directly detect absorption and, hence, does not directly measure the volume waveform **1538** (FIG. 15A). However, the plethysmograph waveform **1502** is merely an out-of-phase version of the volume profile **1538**. Stated differently, the plethysmograph waveform **1502** varies inversely with the pulsatile blood volume **1538**. In particular, the peak detected intensity **1554** occurs at minimum volume **1514** and the minimum detected intensity **1552** occurs at maximum volume **1512**. Further, a rapid rise in volume during the inflow phase **1516** is reflected in a rapid decline in intensity **1556**; and the gradual decline in volume during the outflow phase **1518** is reflected in a gradual increase **1558** in detected intensity. The intensity waveform **1502** also displays a dicrotic notch **1555**.

[0087] FIG. 16 further illustrates a physiological monitoring system **1600** having an optical sensor **1620** attached to a tissue site **10**, a monitor **1610** and an interconnecting sensor cable **1620**. The sensor **1620** has emitters **1622**, each of which transmit light of a specified wavelength. Drivers **1654**, **1655** convert digital control signals into analog drive signals capable of activating the emitters **1622**. A front-end **1652**, **1653** converts composite analog intensity signal(s) from the detector(s) **1624** into digital data input to a digital signal processor (DSP) **1658**. The DSP **1658** may comprise any of a wide variety of data and/or signal processors capable of executing programs for determining physiological parameters from input data. In an embodiment, the DSP executes firmware **1659** including pre-processors, respiration processors and post processors, such as described with respect to FIGS. 1-13, above.

[0088] Also shown in FIG. 16, an instrument manager **1682** may comprise one or more microcontrollers controlling system management, such as monitoring the activity of the DSP **1658**. The instrument manager **1682** has an interface port **1683** for monitor communications. In an embodiment, the interface port **1683** has a display driver, an audio driver, user inputs and I/O for driving displays and alarms, responding to buttons and keypads and providing external device input/output communications. In an embodiment, the displays can indicate a variety of physiological parameters **1686** such as respiration rate (RR), pulse rate (PR), plethysmograph (pleth), perfusion index (PI), pleth variability index (PVI), signal quality (IQ) and values for blood constituents

including oxygen saturation (SpO₂), carboxyhemoglobin (HbCO), methemoglobin (HbMet), total hemoglobin (Hbt) and oxygen content (OC) as well as instrument and sensor status, such as sensor life, to name but a few.

[0089] FIG. 17 illustrates a demodulator 1700 having a modulated/multiplexed detector signal 1703 input and demodulated signal 1705 outputs. That is, the demodulator input 1703 is the result of a detector 1624 (FIG. 16) response to N emitter wavelengths 1622 (FIG. 16) that are cyclically turned on and off by emitter drivers 1654 (FIG. 16) so as to illuminate a tissue site with multiple wavelength optical radiation, as is well known in the pulse oximetry art. The digitized detector signal 1703 corresponds to the A/D converter 1657 (FIG. 16) input to the DSP 1658 (FIG. 16). The DSP has demodulator 1700 (preprocessor) firmware 1659 which generates N channels of demodulated signals r₁(t), r₂(t), . . . , r_N(t) 1705 in response. One signal r_i(t) corresponding to each emitter wavelength 1622. These demodulated signals are plethysmographs, as described above.

[0090] The demodulator 1700 has mixers 1730 and low pass filters 1740 for each channel and demodulating signals d_i(t) 1704 provided to each mixer 1730. The demodulating signals are linear combinations of (orthogonal) basis functions of the form

$$d_i(t) = \sum_{j=1}^M \beta_{ij} \cdot \phi_j(t) \quad (\text{EQ. 5})$$

which are derived by approximating the optical response of the emitters to on/off periods of the emitter drivers. M is the number of basis functions needed to approximate such optical responses. $\phi_j(t)$ is the j^{th} basis function used by the demodulator. In one embodiment, the basis functions are of the form

$$\phi_j(t) = \sin\left(\frac{2\pi}{T} jt + b_j \frac{\pi}{2}\right); b_j \in [0, 1] \quad (\text{EQ. 6})$$

where T is the period of the repeating on/off patterns of the emitter drivers. Accordingly, the lowpass filter outputs 1705 are r₁(t), r₂(t), . . . , r_N(t), which are estimates of absorption for each emitter wavelength in view of noise n(t) that is additive to each channel. Plethysmograph demodulators are described in U.S. Pat. No. 5,919,134 titled Method and Apparatus for Demodulating Signals in a Pulse Oximetry System, issued Jul. 6, 1999; U.S. Pat. No. 7,003,338 titled Method and Apparatus for Reducing Coupling Between Signals, issued Feb. 21, 2006; and U.S. patent application Ser. No. 13/037,321 titled Plethysmograph Filter, filed Feb. 28, 2011; all assigned to Masimo Corporation and incorporated by reference herein.

[0091] Advantageously, a plethysmographic respiration processor 100 (FIG. 1) is implemented on an advanced pulse oximetry monitor or an advanced blood parameter monitor, as described above. Although a plethysmographic respiration processor is described above with respect to deriving respiration rate from a plethysmograph waveform, in other embodiments, a plethysmographic respiration processor may be used to derive other respiration-related parameters. In a particularly advantageous embodiment, a plethysmo-

graphic respiration processor is used in conjunction with an acoustic monitor or combined blood parameter and acoustic monitor so as to improve the accuracy of, robustness of, or otherwise supplement acoustic-derived respiration rate measurements or other acoustic-derived respiration parameters. [0092] A plethysmographic respiration processor has been disclosed in detail in connection with various embodiments. These embodiments are disclosed by way of examples only and are not to limit the scope of the claims herein. One of ordinary skill in art will appreciate many variations and modifications.

1-20. (canceled)

21. A patient monitor configured to determine a respiration rate from a plethysmograph waveform, the patient monitor comprising:

a preprocessor configured to receive a plethysmograph waveform from a noninvasive sensor monitoring a patient and identify a plurality of portions of the plethysmograph waveform which include physiologically acceptable series of plethysmograph waveform pulses; and

one or more processors configured to:

derive a first set of candidate respiration rates from a first respiratory-induced modulation in a portion of the plurality of portions,

derive a second set of candidate respiration rates from a second respiratory-induced modulation in the portion, the second respiratory-induced modulation being different from the first respiratory-induced modulation,

compare the first set of candidate respiration rates and the second set of candidate respiration rates to determine whether any of the first set of candidate respiration rates and any of the second set of candidate respiration rates are at a matching rate within a tolerance, and

generate and output a respiration rate from determining that one of the first set of candidate respiration rates and one of the second set of candidate respiration rates are at the matching rate within the tolerance.

22. The patient monitor of claim 21, wherein the one or more processors is configured to compare the first set of candidate respiration rates and the second set of candidate respiration rates until at least determining that none of at least two of the first set of candidate respiration rates and none of at least two of the second set of candidate respiration rates are at the matching rate within the tolerance.

23. The patient monitor of claim 21, wherein the one or more processors is configured to compare the first set of candidate respiration rates and the second set of candidate respiration rates by comparing individual candidate respiration rates of the first set of candidate respiration rates and individual candidate respiration rates of the second set of candidate respiration rates in an order that depends on a pulse rate for the patient.

24. The patient monitor of claim 21, wherein the one or more processors is configured to:

derive a third set of candidate respiration rates from a third respiratory-induced modulation in the portion, the third respiratory-induced modulation being different from the first respiratory-induced modulation and the second respiratory-induced modulation;

compare the first set of candidate respiration rates, the second set of candidate respiration rates, and the third

- set of candidate respiration rates to determine whether any of the first set of candidate respiration rates, any of the second set of candidate respiration rates, and any of the third set of candidate respiration rates are at the matching rate within the tolerance; and generate and output the respiration rate from determining that the one of the first set of candidate respiration rates, the one of the second set of candidate respiration rates, and one of the third set of candidate respiration rates are at the matching rate within the tolerance.
- 25.** The patient monitor of claim **21**, wherein the portion comprises plethysmograph data captured from monitoring the patient over a period less than 120 seconds.
- 26.** The patient monitor of claim **21**, wherein the one or more processors is configured to:
- generate a plurality of respiration rates from the plurality of portions of the plethysmograph waveform, the plurality of respiration rates including the respiration rate; and
 - derive a combined respiration rate from the plurality of respiration rates.
- 27.** The patient monitor of claim **26**, wherein the one or more processors is configured to:
- determine that an additional respiration rate differs from the combined respiration rate by more than an amount; and
 - reject the additional respiration rate in response to determining that the additional respiration rate differs from the combined respiration rate by more than the amount.
- 28.** The patient monitor of claim **26**, wherein the portion comprises plethysmograph data captured from monitoring the patient over a different period than another portion of the plurality of portions.
- 29.** The patient monitor of claim **21**, wherein the one or more processors is configured to generate and output the respiration rate from determining that the one of the first set of candidate respiration rates and the one of the second set of candidate respiration rates are at the matching rate within the tolerance and from determining that an additional condition is met.
- 30.** The patient monitor of claim **29**, wherein the additional condition is met when the respiration rate differs from another respiration rate by less than an amount.
- 31.** The patient monitor of claim **21**, wherein the first respiratory-induced modulation comprises a respiratory-induced baseline shift of the portion, and the second respiratory-induced modulation comprises a respiratory-induced amplitude modulation of the portion.
- 32.** The patient monitor of claim **21**, wherein the first respiratory-induced modulation comprises a respiratory-induced baseline shift of the portion, and the second respiratory-induced modulation comprises a respiratory-induced shape modulation of the portion.
- 33.** The patient monitor of claim **21**, wherein the first respiratory-induced modulation comprises a respiratory-induced amplitude modulation of the portion, and the second respiratory-induced modulation comprises a respiratory-induced shape modulation of the portion.
- 34.** The patient monitor of claim **21**, further comprising a display configured to present the respiration rate.
- 35.** The patient monitor of claim **21**, wherein the respiration rate comprises the one of the first set of candidate respiration rates.
- 36.** The patient monitor of claim **21**, further comprising the noninvasive sensor.
- 37.** A method for determining a respiration rate from a plethysmograph waveform, the method comprising:
- receiving a plethysmograph waveform from a noninvasive sensor monitoring a patient;
 - identifying a plurality of portions of the plethysmograph waveform which include physiologically acceptable series of plethysmograph waveform pulses;
 - deriving, by one or more processors, a first set of candidate respiration rates from a first respiratory-induced modulation in a portion of the plurality of portions;
 - deriving, by the one or more processors, a second set of candidate respiration rates from a second respiratory-induced modulation in the portion, the second respiratory-induced modulation being different from the first respiratory-induced modulation;
 - comparing, by the one or more processors, the first set of candidate respiration rates and the second set of candidate respiration rates to determine whether any of the first set of candidate respiration rates and any of the second set of candidate respiration rates are at a matching rate within a tolerance; and
 - generating and outputting, by the one or more processors, a respiration rate from determining that one of the first set of candidate respiration rates and one of the second set of candidate respiration rates are at the matching rate within the tolerance.
- 38.** The method of claim **37**, wherein said comparing comprises comparing individual candidate respiration rates of the first set of candidate respiration rates and individual candidate respiration rates of the second set of candidate respiration rates in an order that depends on a pulse rate for the patient.
- 39.** The method of claim **37**, further comprising deriving, by the one or more processors, a third set of candidate respiration rates from a third respiratory-induced modulation in the portion, the third respiratory-induced modulation being different from the first respiratory-induced modulation and the second respiratory-induced modulation, wherein said comparing comprises comparing the first set of candidate respiration rates, the second set of candidate respiration rates, and the third set of candidate respiration rates to determine whether any of the first set of candidate respiration rates, any of the second set of candidate respiration rates, and any of the third set of candidate respiration rates are at the matching rate within the tolerance, and wherein said generating and outputting comprises generating and outputting the respiration rate from determining that the one of the first set of candidate respiration rates, the one of the second set of candidate respiration rates, and one of the third set of candidate respiration rates are at the matching rate within the tolerance.
- 40.** The method of claim **37**, wherein the portion comprises plethysmograph data captured from monitoring the patient over a period less than 120 seconds.

专利名称(译)	体积描记呼吸率检测		
公开(公告)号	US20190076028A1	公开(公告)日	2019-03-14
申请号	US16/119215	申请日	2018-08-31
[标]申请(专利权)人(译)	梅西莫股份有限公司		
申请(专利权)人(译)	Masimo公司		
当前申请(专利权)人(译)	Masimo公司		
[标]发明人	AL ALI AMMAR MAJMUDAR ANMOL		
发明人	AL-ALI, AMMAR MAJMUDAR, ANMOL		
IPC分类号	A61B5/0205 A61B5/026 A61B5/0295 A61B5/08 A61B5/00 A61B5/029 A61B5/02 A61B5/1455		
CPC分类号	A61B5/08 A61B5/0261 A61B5/0205 A61B5/7228 A61B5/7264 A61B5/7405 A61B5/742 A61B5/746 A61B5/02007 A61B5/7475 A61B5/029 A61B5/0806 A61B5/14552 A61B5/6826 A61B5/7203 A61B5/ 7225 A61B5/7278 A61B5/7253 A61B5/725 A61B5/0295 A61B5/0816		
优先权	61/319256 2010-03-30 US 61/364141 2010-07-14 US		
外部链接	Espacenet USPTO		

摘要(译)

体积描记呼吸处理器响应于出现在血液体积波形上的呼吸效应和在血液灌注的外周组织部位用光学传感器测量的相应的检测强度波形，以便提供呼吸率的测量。预处理器识别对应于生理学上可接受的一系列体积描记器波形脉冲的窗口化的体积。多个处理器响应于窗口体积上的特定呼吸效应而导出不同的参数。判定逻辑基于这些参数的至少一部分确定呼吸率。

