



US 20180256061A1

(19) **United States**

(12) **Patent Application Publication**
Landgraf et al.

(10) **Pub. No.: US 2018/0256061 A1**

(43) **Pub. Date: Sep. 13, 2018**

(54) **WIRELESS CARDIAC SENSOR**

(71) Applicant: **Eko Devices, Inc.**, Berkeley, CA (US)

(72) Inventors: **Connor Landgraf**, San Francisco, CA (US); **Philip Goolkasian**, San Francisco, CA (US); **Tyler Crouch**, San Francisco, CA (US)

(73) Assignee: **Eko Devices, Inc.**

(21) Appl. No.: **15/455,987**

(22) Filed: **Mar. 10, 2017**

Publication Classification

(51) **Int. Cl.**
A61B 5/0408 (2006.01)
A61B 5/00 (2006.01)
A61B 7/04 (2006.01)

(52) **U.S. Cl.**
CPC *A61B 5/04085* (2013.01); *A61B 5/684* (2013.01); *A61B 2562/16* (2013.01); *A61B 7/04* (2013.01); *A61B 5/6843* (2013.01); *A61B 5/0006* (2013.01)

(57) **ABSTRACT**

A wireless cardiac sensor is provided. The sensor may be utilized by a patient, on themselves, in an at home or other non-clinical environment. A sensor housing contains ECG electrodes and an audio transducer to simultaneously capture heart sound and ECG data with a single device. The ECG electrodes may be positioned on opposite sides of, and preferably adjacent to, an audio transducer sensor, for placement against a user's chest. The wireless cardiac sensor may include a button on a surface opposite the ECG electrodes and audio sensor, facilitating one-handed operation by a patient. The sensor transmits acquired data to a personal electronic device, such as a smartphone, via a wireless communication link. The personal electronic device may in turn transmit data to a centralized server and/or health care provider devices, via a wide area network.

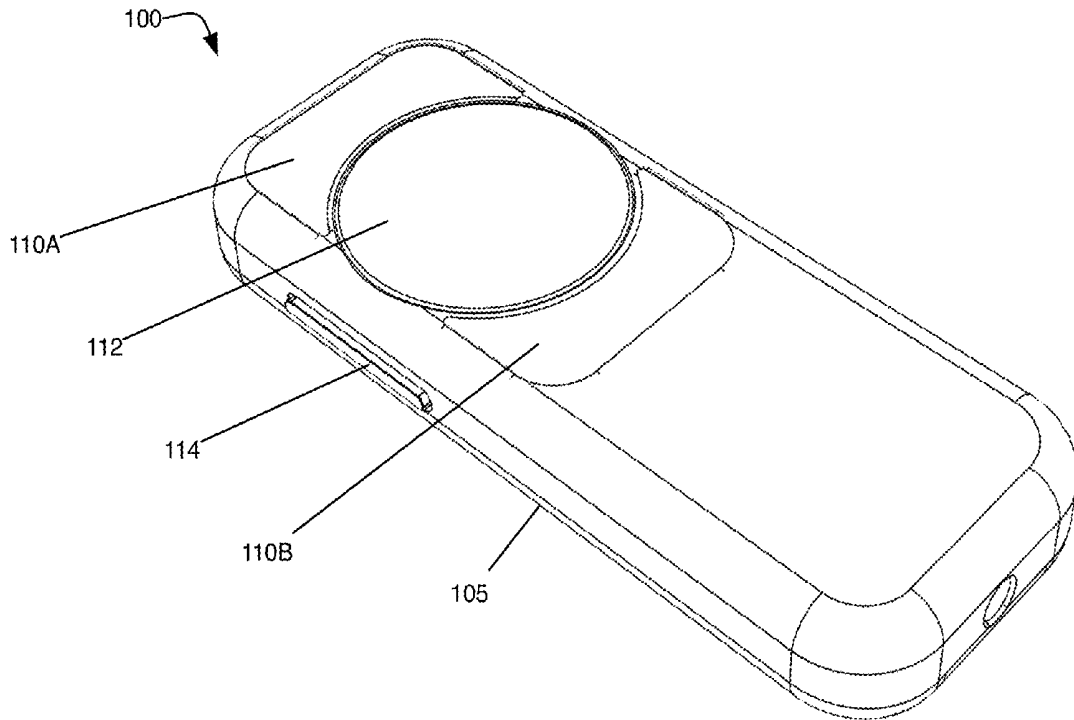

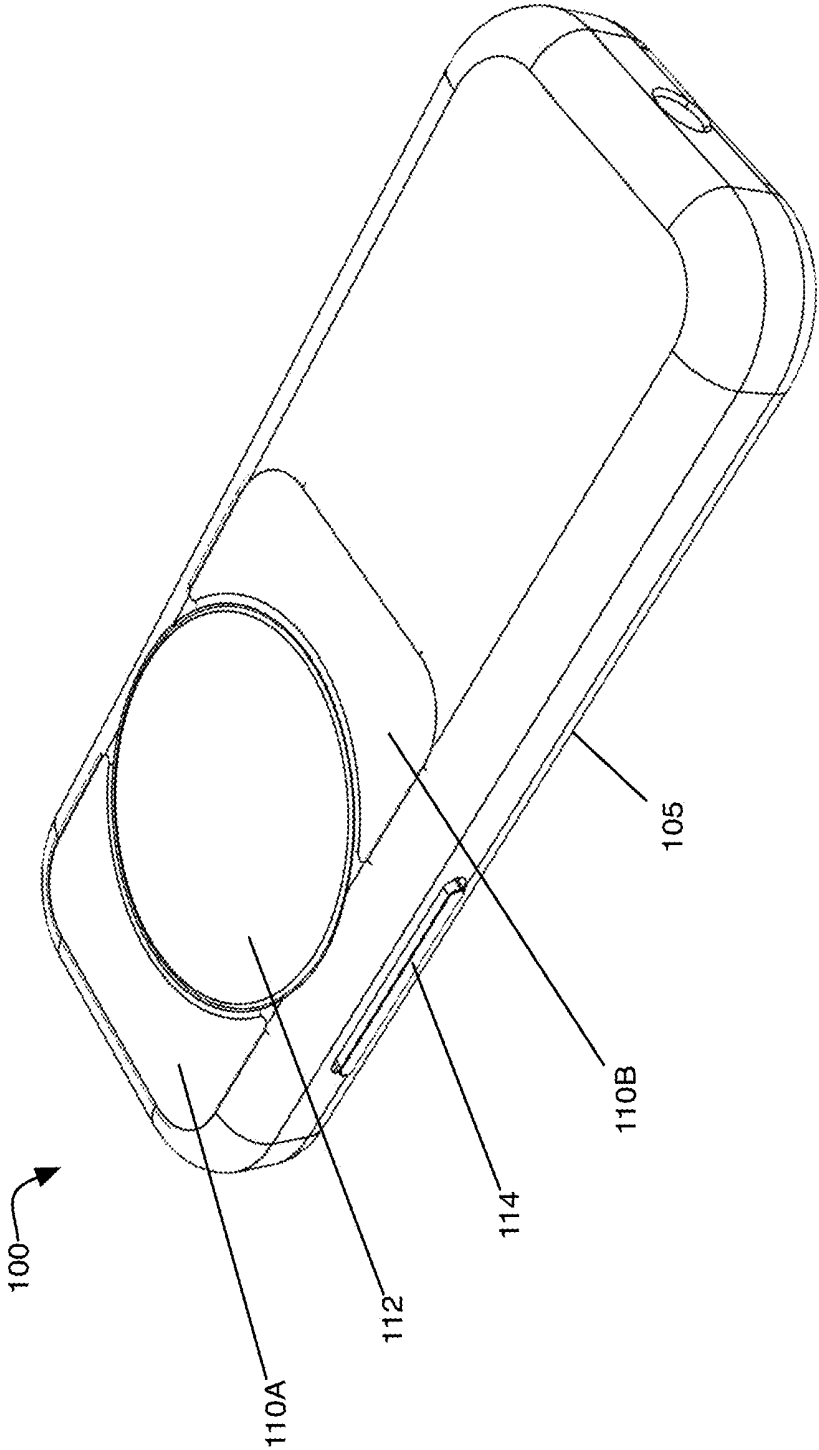

FIG. 1

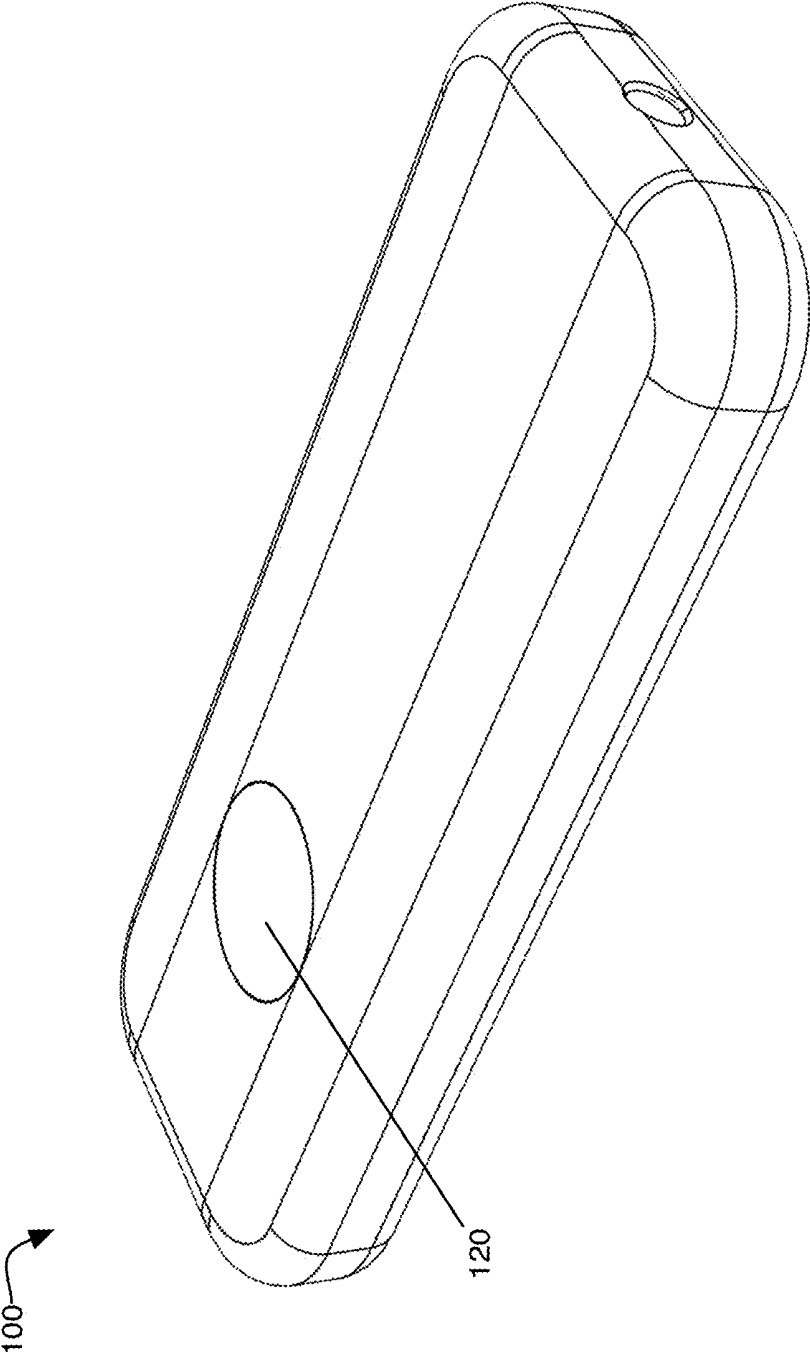

FIG. 2

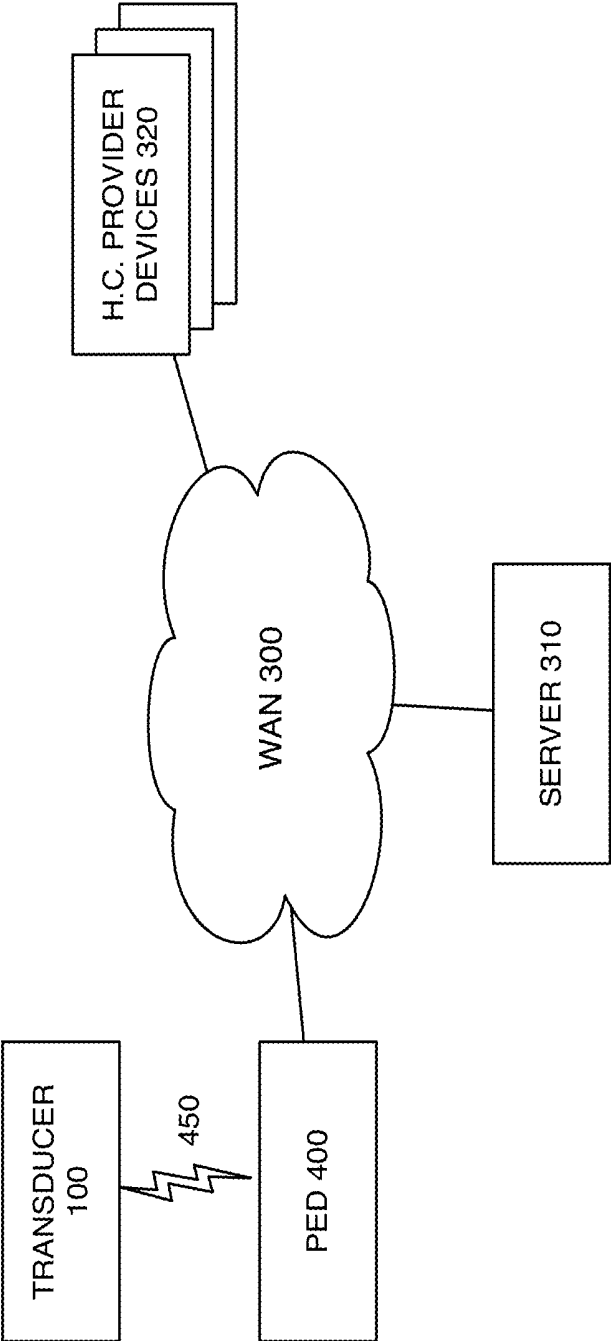

FIG. 3

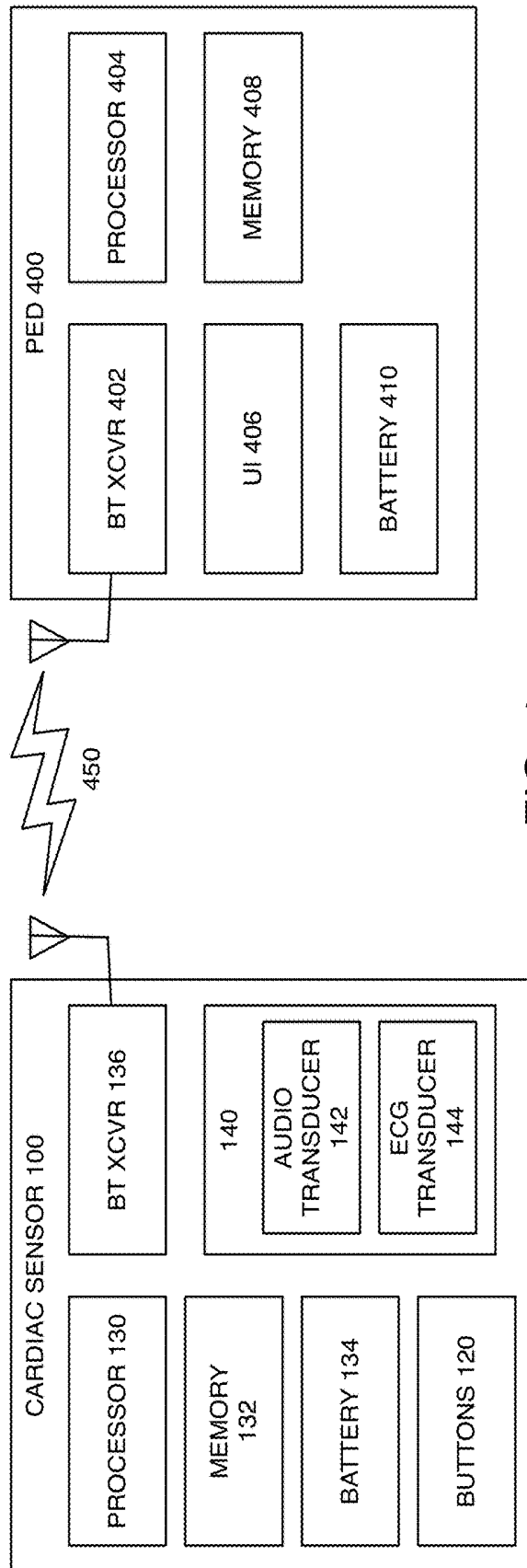

FIG. 4

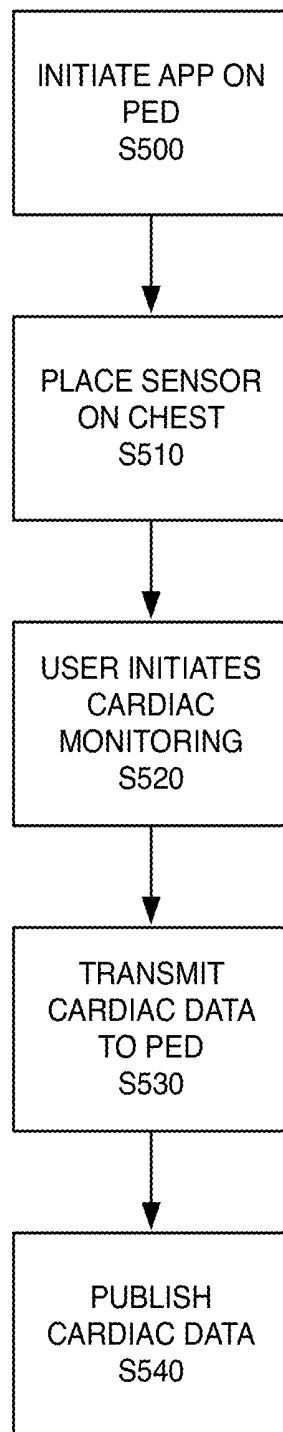

FIG. 5

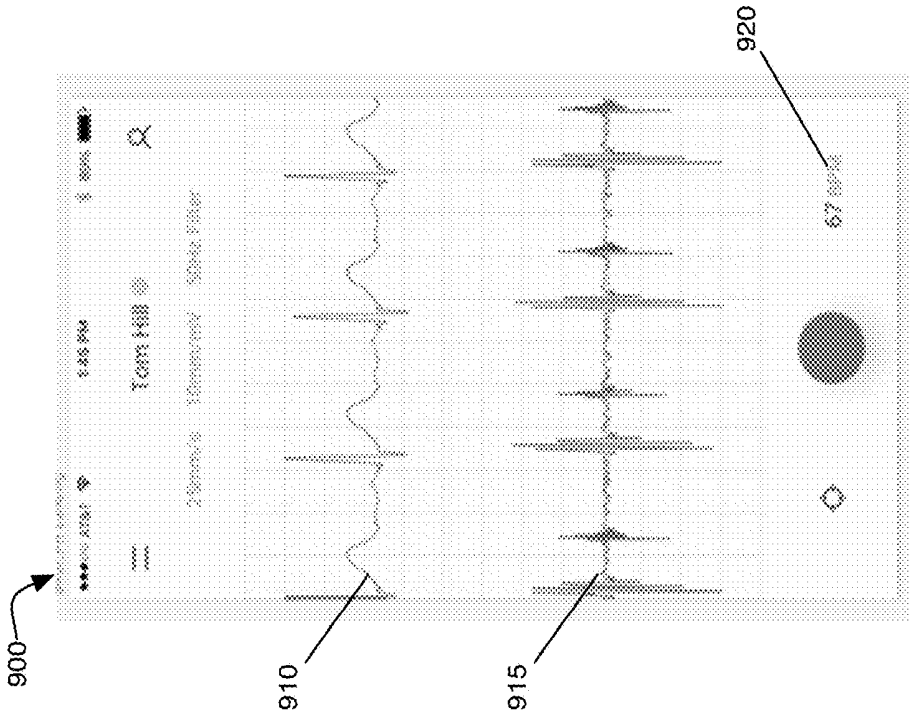

FIG. 9

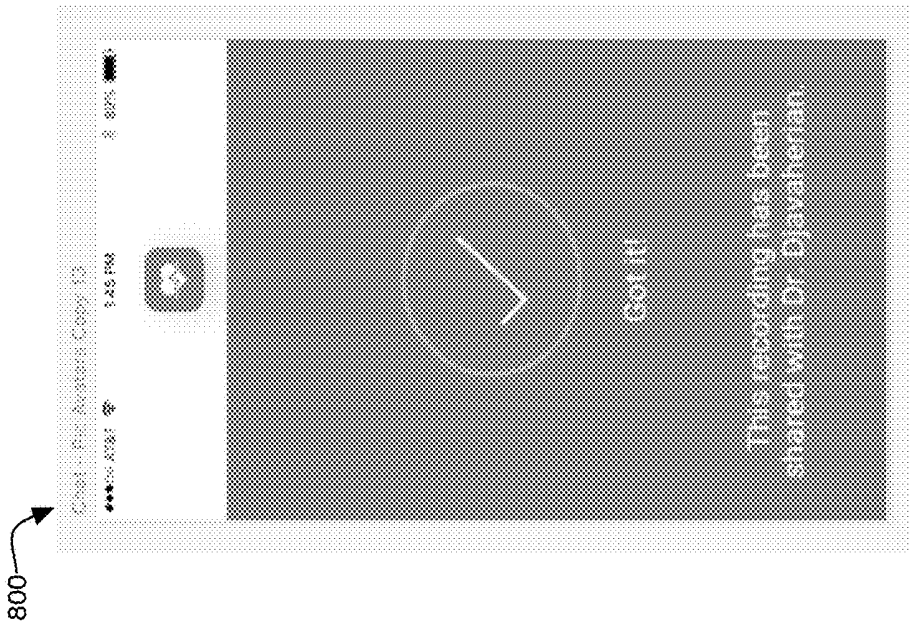

FIG. 8

WIRELESS CARDIAC SENSOR

TECHNICAL FIELD

[0001] The present disclosure relates to medical devices utilizing wireless electronic communications. More specifically, this disclosure relates to wireless mobile cardiac sensors and uses thereof.

BACKGROUND

[0002] As healthcare costs continue to escalate, solutions to reduce the cost and improve the efficacy of diagnostic efforts become increasingly important. In other situations, improving access to medical diagnostic and monitoring capabilities may be desirable. These objectives may be particularly valuable for cardiac care, since cardiac function is vital to human health and well-being, and cardiovascular diseases continue to be the most common cause of death.

[0003] However, traditional cardiac monitoring and evaluation tools are not well-suited to non-clinical environments. Equipment may be costly and difficult to use for untrained lay users. Cardiac monitoring equipment often involves numerous sensors, requiring specific placement, which may be difficult and time consuming for lay users to apply, and particularly difficult for a user to apply to themselves—thereby preventing or discouraging regular use. Sensor cables can become tangled, pulled and damaged, further frustrating users and reducing equipment reliability. In addition, the majority of all cardiac monitors currently providing continuous monitoring are limited to a short period of time, typically 2 weeks or 30 days. This time limitation is very significant because many cardiac conditions manifest themselves over a long period of months or years, where a short continuous monitoring window will not be useful for the lifetime of the disease. In view of these and other issues, traditional cardiac monitoring equipment may be particularly unsatisfactory for use by patients at their homes, or in other non-clinical environments.

SUMMARY

[0004] A wireless cardiac sensor is provided. In some embodiments, the sensor may be effectively used by lay users in an at home or other non-clinical environment. The sensor includes an audio transducer and ECG electrodes to simultaneously capture heart sound and ECG data. The audio transducer includes a sensor that, together with ECG transducer electrodes, may be positioned on a front surface of a wireless cardiac sensor housing. In some embodiments, ECG electrodes may be arranged on opposite sides of, and preferably adjacent to, the audio transducer sensor.

[0005] A button may be provided for user interaction with the wireless cardiac sensor. The button may be used for initiating a cardiac monitoring function. The button may be positioned on a back surface of the wireless cardiac sensor, preferably opposite the audio transducer sensor and ECG electrodes, such that the application of pressure on the button may operate to improve contact with the user's body when in use. Thus, in some applications, the wireless cardiac sensor may be applied to a user's own body, with one hand.

[0006] The wireless cardiac sensor may also include a wireless transceiver, for transmitting measured cardiac data to a separate personal electronic device, such as a smartphone, tablet computer, or personal computer. In some embodiments, the wireless cardiac sensor includes a Blu-

etooth transceiver, for exchanging data with a personal electronic device via a Bluetooth communications link. The personal electronic device includes user interface components, such as a display screen. The personal electronic device display screen may present instructions for proper sensor placement to the user. The personal electronic device may process cardiac data received from the wireless cardiac sensor, and display diagnostic information derived therefore. Data from the wireless cardiac sensor may be stored locally within the personal electronic device, and/or transmitted to remote computing systems for storage and/or analysis.

BRIEF DESCRIPTION OF THE FIGURES

[0007] FIG. 1 is a front perspective view of a wireless cardiac sensor, in accordance with one embodiment.

[0008] FIG. 2 is a rear perspective view of a wireless cardiac sensor.

[0009] FIG. 3 is a schematic block diagram of a wireless cardiac sensor computing environment.

[0010] FIG. 4 is a schematic block diagram of a wireless cardiac sensor and a personal electronic device, communicating via a wireless communication channel.

[0011] FIG. 5 is a process for using a wireless cardiac sensor.

[0012] FIG. 6 is an instructional user interface display on a personal electronic device.

[0013] FIG. 7 is an instructional user interface display on a personal electronic device.

[0014] FIG. 8 is an informational user interface display on a personal electronic device.

[0015] FIG. 9 is a user interface display of acquired sensor data on a personal electronic device.

DETAILED DESCRIPTION OF THE DRAWINGS

[0016] While this invention is susceptible to embodiment in many different forms, there are shown in the drawings and will be described in detail herein several specific embodiments, with the understanding that the present disclosure is to be considered as an exemplification of the principles of the invention to enable any person skilled in the art to make and use the invention, and is not intended to limit the invention to the embodiments illustrated.

[0017] In accordance with some embodiments, a portable cardiac transducer may be provided that is portable, cost-effective, and simple-to-use for layperson and self-diagnostic applications.

[0018] FIG. 1 is a front perspective view of a wireless cardiac sensor **100**. Housing **105** encases circuitry described further hereinbelow, and is preferably formed from plastic or other non-conductive material. Housing **105** is generally rectangular cuboid in shape, with rounded edges. Sensor **100** further includes ECG transducer electrodes **110A** and **110B**, positioned on a front side of housing **105**. Electrodes **110A** and **110B** are physically separated from one another to facilitate measurement of electrical signals on a person's skin resulting from depolarization of the person's heart muscle during each heartbeat, when appropriately positioned, e.g., against a user's chest on the user's left pectoral region.

[0019] In the embodiment of FIG. 1, electrodes **110A** and **110B** are positioned adjacent to, and on opposite sides of, acoustic sensor **112**, which is also positioned on the front side of transducer **100**. When placed against a user's chest,

acoustic sensor **112** may be utilized to detect, record and/or characterize a user's heart sounds, as conducted acoustically through their chest wall. Acoustic sensor **112** may be a piezoelectric sensor, which along with associated analog-to-digital converters and signal processing components, forms audio transducer **142** (FIG. 4). Collectively, ECG electrodes **110A** and **110B** and acoustic sensor **112** form a sensor package occupying a portion of the front side of sensor housing **105**.

[0020] By providing an integrated ECG and heart sound sensor within a unitary housing communicating with a wireless communication protocol, cardiac sensor **100** provides significant usability and reliability benefits, particularly for layperson users and/or users of the cardiac sensor in home, field and other non-clinical environments. For example, combining ECG and heart sound sensors in a unitary package allows an individual to easily use the device on themselves, using one hand. Combining ECG and heart sound sensors in one package allows for precise examination of the electrical and mechanical characteristics of the heart. Positioning electrodes **110** and sensor **112** proximate one another, and preferably adjacent, provides a unitary sensor package for a user to position on their chest. The absence of lead wires prevents users from become entangled in wires. The absence of lead wires also improves reliability, as kinked, pulled or tangled cords and strained connectors are common points of failure for conventional cardiac sensors.

[0021] The shape and design of the sensor housing is optimized to balance multiple factors, including (1) comfort for a user to securely hold against their own chest (fits in the hand); (2) secure fit against a wide variety of patient body types and shapes, male and female, for good contact with electrodes **110A/B** and acoustic sensor **112**; (3) providing sufficient physical separation of the two ECG electrodes to provide accurate signal quality; and (4) providing an audio transducer sensor of sufficient diameter for optimal detection of heart and lung sound frequencies. The ECG electrodes are of a sufficient size to allow good electrical contact between the patient's skin and the electrode even if the patient has chest hair or curves of their skin. The ECG electrodes are of a set separation distance to allow for precision placement over the iso-electric lines of the heart.

[0022] FIG. 2 is a rear perspective view of wireless cardiac transducer **100**. A rear portion of housing **105** includes button **120**. Button **120** may be actuated by a user in order to initiate signal measurement by transducers **140** (FIG. 4, described further below). By placing button **120** on a surface of housing **105** that is opposite electrodes **110** and audio sensor **112**, and positioned on that opposing surface at a location that is approximately centered over sensors **110** and **112**, force applied by a user pressing button **120** during a measurement serves to press electrodes **110** and sensor **112** directly against the user's skin, thereby improving quality of contact with the user's skin. This configuration may be particularly helpful for applications in which a person is using wireless cardiac sensor **100** on themselves, in a one-handed mode of operation.

[0023] FIG. 3 is a schematic block diagram of an environment in which wireless cardiac transducer **100** may be beneficially employed. Transducer **100** communications with personal electronic device ("PED") **400** via wireless communications link **450**, as described further hereinbelow. In some applications, PED **400** may be a computing device having diverse functionality and used for multiple purposes,

such as a smartphone, tablet computer, smart watch, laptop computer, desktop computer, voice-controlled home assistant or the like. By integrating functionality between transducer **100** and PED **400**, PED **400** can be used to implement various elements of functionality that are beneficial to use of transducer **100**, thereby reducing the cost and complexity of transducer **100**. For example, in some embodiments, PED **400** may be a smartphone having a graphical display, touchscreen and application software enabling exchange of data and control signaling with transducer **100**.

[0024] PED **400** communicates with other systems and devices via wide area network (WAN) **300**, which may include the Internet. In some embodiments, server **310** may be provided to implement services associated with transducer **100**, such as data storage, data analysis, data publication, as well as web applications and/or application programming interfaces for same. Health care provider devices **320** are electronic systems and devices used by health care service providers, in order to exchange information with server **310** and/or PED **400**, as described further hereinbelow. Devices **320** may include smartphones, tablet computers, personal computers, or healthcare service provider computing systems or equipment.

[0025] FIG. 4 is a detailed schematic block diagram of cardiac sensor **100**, as it interacts with PED **400**. Cardiac sensor **100** includes microprocessor **130** and digital memory **132**. Battery **134** is a rechargeable battery serving to power wireless transducer **100** during operation. In some embodiments, it may be desirable for battery **134** to incorporate wireless charging circuitry, thereby enabling further minimization or avoidance of ports and other apertures within the cardiac sensor housing.

[0026] Transducer package **140** include audio transducer **142**. Audio transducer **142** includes piezoelectric sensor **112**; an analog-to-digital converter to digitize audio signals detected by sensor **112**; as well as signal processing circuitry to filter and condition detected signals. Audio signal processing circuitry may be implemented in the analog domain (i.e. prior to digitization), in the digital domain (i.e. by microprocessor **130** and/or a dedicated digital signal processing integrated circuit) or both.

[0027] Transducer package **140** also includes ECG transducer **144**. ECG transducer **144** includes ECG electrodes **110A** and **110B**; an analog-to-digital converter to digitize voltage differentials measured by electrodes **110A** and **110B**; as well as signal processing circuitry to filter and conditions detected signals. ECG signal processing circuitry may be implemented in the analog domain (i.e. prior to digitization), in the digital domain (i.e. by microprocessor **130** and/or a dedicated digital signal processing integrated circuit) or both.

[0028] Cardiac sensor wireless transceiver **136** is preferably a Bluetooth transceiver, enabling wireless digital communications with other Bluetooth-enabled devices, such as PED **400**, via wireless communication link **450**. In some embodiments, PED **400** may be a standard, commodity mobile wireless computing device, such as a smartphone (e.g. Apple iPhone™), tablet computer (e.g. Apple iPad™), or laptop computer. In other embodiments, PED **400** may less preferably be a dedicated computing device, such as a central sensor monitoring station with embedded software. PED **400** includes wireless (e.g. Bluetooth) transceiver **402**, microprocessor **404**, user interface components **406** (such as a touch-sensitive display screen, or combinations of graphi-

cal display, keyboard, mouse, touchpad or the like), digital memory 408 for data storage, and battery 410 for cordless operation. Various wireless communication protocols may be utilized to convey data between cardiac sensor 100 and PED 400, including, without limitation, those described in applicant's co-pending U.S. patent application Ser. No. 15/384,506, filed on Dec. 20, 2016, the contents of which are hereby incorporated by reference in their entirety.

[0029] By providing a cardiac sensor 100 which is compact in size, while leveraging a user's existing personal electronic device 400 for functions such as data storage, analysis, transmission and user interaction, cardiac sensor 100 may be relatively inexpensive as compared to alternative solutions.

[0030] FIG. 5 illustrates an exemplary process for using cardiac sensor 100. In step S500, a user initiates use of a software application installed on PED 400. For example, in an embodiment in which PED 400 is a smartphone, a smartphone app may be downloaded and installed on PED 400. The app may subsequently be executed by processor 404 to control operation of PED 400. When launched, the app may provide guidance and instructions to the user via UI 406. For example, the app may provide visual displays on a display screen to illustrate proper placement of cardiac sensor 100 on the user's body.

[0031] In step S510, a user places cardiac sensor 100 into contact with their chest, preferably over their left pectoral area and with guidance displayed on PED UI 406. Electrodes 110A and 110B contact the user's chest, enabling ECG transducer 144 to measure electrical changes on the skin occurring as a result of the heart muscle's electrophysiologic pattern of depolarization during each heartbeat. Simultaneously, piezoelectric sensor 112 makes physical contact with the user's chest to detect heart sounds conducted through the user's chest wall to audio transducer 142.

[0032] In step S520, the user presses button 120 to initiate cardiac monitoring. Specifically, depression of button 120 initiates simultaneous recording of ECG and heart sound data by transducer package 140. With a cardiac sensor embodiment such as that of FIGS. 1 and 2, a user may readily hold sensor 100 against their own chest with one hand, while utilizing one finger to press button 120.

[0033] In step S530, cardiac sensor 100 captures cardiac data generated by transducers 140 and transmits that data to PED 400. In the course of doing so, electrical signals generated by transducers 142 and 144 are digitized using analog-to-digital converters. Various filters and other signal processing operations may be performed on the sensed ECG and heart sound signals, either locally within cardiac sensor 100, remotely by PED 400, or elsewhere. Data may be stored for a period of time locally within cardiac sensor memory 132, before, during and/or after transmission to PED 400. Preferably, ECG and heart sound data is streamed in near-real time from sensor 100 to PED 400 via wireless communication link 450. Such cardiac data is then stored locally within PED 400 by digital memory 408.

[0034] In step S540, cardiac data received by PED 400 may be published to other stakeholders in a user's care. For example, in some embodiments, PED 400 (under control of the application initiated in step S500) may transmit recorded cardiac data to a centralized server 310 via WAN 300. Server 310 may then make the recorded cardiac data available to other services, such as health care provider computing devices 320 accessing server 310 via a web application or

application programming interface. In such a use case, a patient using cardiac monitor 100 at home or in another non-clinical environment, may make data from cardiac sensor 100 available to doctors or other health care professionals in remote locations for expert diagnostic purposes.

[0035] In some embodiments, cardiac data may be streamed from sensor 100 to PED 400 to server 310, such that the data may be made available to third parties in near-real time. In some embodiments, data from cardiac monitoring sessions may be stored over time within server 310, providing a repository of historical data for subsequent analysis by, e.g., health care professionals.

[0036] In some embodiments, PED 400 may also retain a repository of historical cardiac monitoring data, with local software applications operating on PED 400 providing tools for analyzing such data and providing diagnostic results based thereon, delivered via displays on UI 406.

[0037] In some embodiments, the PED 400 may provide feedback to the user on the quality of the ECG and PCG (phonocardiogram) signals obtained, preferably including a voice-based audio feedback system to communicate this information to the user during the process of signal acquisition. In particular, PED 400 may execute a local application on microprocessor 404, to assess sensor data received via transceiver 402 and, based on that assessment, workflow logic and/or other logic implemented by the local application, provide feedback to the user via user interface 406, preferably including audio instructions and feedback via an audio loudspeaker within UI 406. For example, upon initiating a cardiac monitoring session, PED 400 may render user interface display 600 (FIG. 6) on a display screen to prompt the user regarding positioning of sensor 100, while simultaneously playing audio instructions as well. After the user presses a button to start measurement, PED 400 may render user interface display 700 (FIG. 7) on the PED display screen to instruct the user to remain still during the measurement. The audio and/or visual feedback will alert the user when a data capture is complete or when data quality is poor.

[0038] In some embodiments, PED 400 will alert the user when a data capture is reviewed by a physician or clinician and/or is sent to the physician or clinician (such as via transmission from PED 400 to healthcare provider device 320 via wide area network 300). In particular, PED 400 may render user interface 800 (FIG. 8) to confirm transmission of sensor data to a health care provider.

[0039] PED 400 may also operate to display data acquired via sensor 100 for user review. FIG. 9 illustrates a user interface display 900 that may be rendered on a display screen. Display 900 includes two continuous waveforms 910 and 915 of the ECG and PCG data, allowing a user to compare differences or similarities between the data. Display 900 includes other diagnostic as well, derived from waveforms 910 and 915, such as heart rate output 920.

[0040] The foregoing description of the disclosed embodiments is provided to enable any person skilled in the art to make or use the invention disclosed herein. Various modifications to these embodiments will be readily apparent to those skilled in the art, and the generic principles defined herein may be applied to other embodiments without departing from the spirit or scope of the disclosure. Thus, the present disclosure is not intended to be limited to the embodiments shown herein but is to be accorded the widest

scope consistent with the principles and novel features disclosed herein. All references cited herein are expressly incorporated by reference.

What is claimed is:

1. A wireless cardiac sensor comprising:
 - a sensor housing having a first side for positioning against a user's chest;
 - a battery within the sensor housing for powering the sensor;
 - an ECG transducer within the sensor housing, the ECG transducer comprising plurality of electrodes exposed on the first side of the sensor housing;
 - an audio transducer within the sensor housing, the audio transducer comprising an audio transducer sensor exposed on the first side of the sensor housing; and
 - a wireless transceiver, the transceiver adapted for transmitting data recorded by the ECG transducer and the audio transducer to a personal electronic device proximate the cardiac sensor.
2. The cardiac sensor of claim 1, in which the ECG transducer comprises two electrodes positioned on opposite sides of the audio transducer sensor.
3. The cardiac sensor of claim 2, in which the ECG electrodes are adjacent to the audio transducer sensor.
4. The cardiac sensor of claim 1, in which the sensor housing is approximately rectangular cuboid in shape.
5. The cardiac sensor of claim 1, in which the sensor housing also has a second side opposite the first side, the sensor further comprising a button for actuation by a user, the button exposed on the second side of the sensor housing and positioned directly above one or more of the audio transducer sensor and ECG electrodes.
6. The cardiac sensor of claim 5, in which the button is centered over a sensor package comprised of the ECG electrodes and audio transducer sensor, whereby application of pressure on the button by a user holding the sensor against the user's chest promotes contact of the sensor with the user's chest.
7. The cardiac sensor of claim 1, further comprising a separate personal electronic device ("PED"), the PED comprising:
 - a PED wireless transceiver configured for communication with the sensor wireless transceiver to convey cardiac data therebetween;
 - a user interface comprising a graphical display screen configured to render displays conveying diagnostic information derived from cardiac data received by the PED wireless transceiver.
8. A method for monitoring the cardiac function of a human using a wireless cardiac sensor and a personal electronic device, the method comprising the steps of:
 - initiating a cardiac monitoring application on the personal electronic device;
 - positioning against the human's chest, an audio transducer sensor and a plurality of ECG electrodes arranged within a unitary wireless cardiac sensor housing on a first side thereof;
 - initiating cardiac monitoring by the human, whereby the wireless cardiac sensor captures data indicative of the human's cardiac function via the ECG electrodes and audio transducer sensor;
 - transmitting data indicative of cardiac function from the wireless cardiac sensor to the personal electronic device; and
 - displaying cardiac diagnostic information on a display screen within the personal electronic device, the cardiac diagnostic information derived from the data transmitted from the wireless cardiac sensor.
9. The method of claim 8, in which the step of initiating a cardiac monitoring application on the personal electronic device comprises displaying, on the personal electronic device, instructions for positioning of a wireless cardiac sensor on the human's chest.
10. The method of claim 8, in which the step of initiating cardiac monitoring by the human comprises the substep of pressing a button positioned on a side of the wireless cardiac sensor opposite the side on which the audio transducer sensor and ECG electrodes are arranged.
11. The method of claim 8, in which the step of positioning against the human's chest an audio transducer sensor and a plurality of ECG electrodes, comprises the substep of holding the wireless cardiac sensor by the human against their own chest using one hand, with one finger positioned over the button.
12. The method of claim 8, further comprising transmitting the data indicative of cardiac function from the personal electronic device to a network-connected server; and storing the data by the network-connected server for subsequent analysis by a health care professional.
13. The method of claim 8, further comprising transmitting the data indicative of cardiac function from the personal electronic device to a health care professional computing device via the Internet, for remote diagnostic analysis.

* * * * *

专利名称(译)	无线心脏传感器		
公开(公告)号	US20180256061A1	公开(公告)日	2018-09-13
申请号	US15/455987	申请日	2017-03-10
[标]申请(专利权)人(译)	EKO DEVICES		
申请(专利权)人(译)	EKO DEVICES , INC.		
当前申请(专利权)人(译)	EKO DEVICES , INC.		
[标]发明人	LANDGRAF CONNOR GOOLKASIAN PHILIP CROUCH TYLER		
发明人	LANDGRAF, CONNOR GOOLKASIAN, PHILIP CROUCH, TYLER		
IPC分类号	A61B5/0408 A61B5/00 A61B7/04		
CPC分类号	A61B5/04085 A61B5/684 A61B2562/16 A61B7/04 A61B5/6843 A61B5/0006 A61B5/024 A61B5/6898		
外部链接	Espacenet USPTO		

摘要(译)

提供无线心脏传感器。传感器可以由患者自身，在家中或其他非临床环境中使用。传感器外壳包含ECG电极和音频传感器，可同时通过单个设备捕获心音和ECG数据。ECG电极可以位于音频换能器传感器的相对侧，并且优选地邻近音频换能器传感器，用于放置在用户的胸部上。无线心脏传感器可以包括与ECG电极和音频传感器相对的表面上的按钮，便于患者进行单手操作。传感器经由无线通信链路将所获取的数据发送到诸如智能手机的个人电子设备。个人电子设备又可以经由广域网将数据发送到集中式服务器和/或健康护理提供者设备。

