



US 20200197195A1

(19) **United States**

(12) **Patent Application Publication**

Saenz Espinoza et al.

(10) **Pub. No.: US 2020/0197195 A1**

(43) **Pub. Date: Jun. 25, 2020**

(54) **FITTING SYSTEM**

Publication Classification

(71) Applicant: **ADAPTTECH LIMITED,**
Birmingham (GB)

(51) **Int. Cl.**
A61F 2/76 (2006.01)
A61F 2/80 (2006.01)
A61B 5/00 (2006.01)

(72) Inventors: **Mario Saenz Espinoza,** Porto (PT);
Frederico Alberto Abreu Carpinteiro,
Porto (PT)

(52) **U.S. Cl.**
CPC *A61F 2/76* (2013.01); *A61F 2/80*
(2013.01); *A61B 5/68335* (2017.08); *A61B*
5/0064 (2013.01); *A61B 5/0073* (2013.01);
A61B 5/0082 (2013.01); *A61B 2562/0295*
(2013.01); *A61F 2002/7665* (2013.01); *A61B*
2562/0247 (2013.01); *A61B 2562/0219*
(2013.01); *A61B 2562/0271* (2013.01); *A61B*
2562/029 (2013.01); *A61F 2002/7635*
(2013.01)

(21) Appl. No.: **16/075,082**

(22) PCT Filed: **Jan. 15, 2018**

(86) PCT No.: **PCT/EP2018/050888**

§ 371 (c)(1),

(2) Date: **Aug. 2, 2018**

(57) **ABSTRACT**

A method and apparatus to scan and measure the surface of objects using a radiation source, such as a laser. When combined with bio-data from bio-sensors to create a profile, the invention is particularly useful for measuring the internal surface of a prosthetic socket and improving the fit between the socket and the residual limb.

(30) **Foreign Application Priority Data**

Jan. 13, 2017 (LU) LU100021

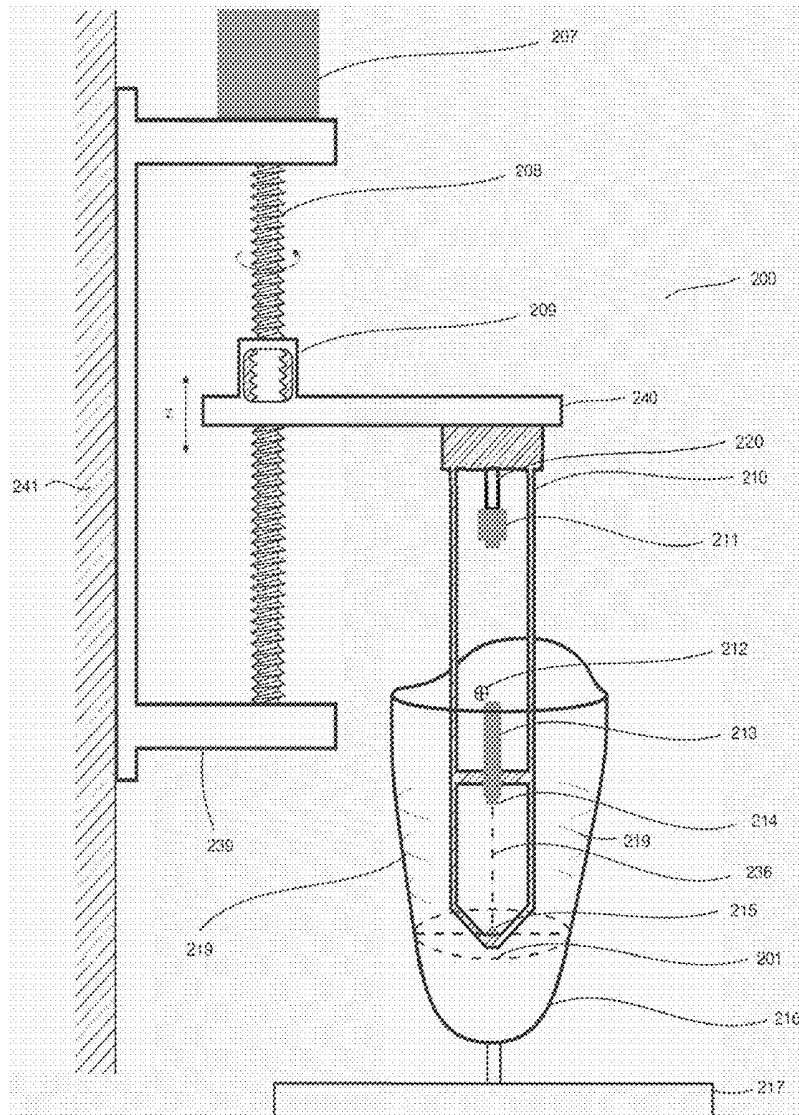

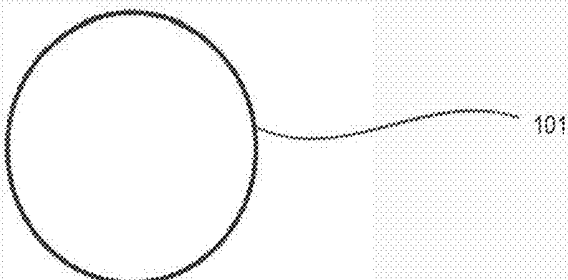

Fig. 1A

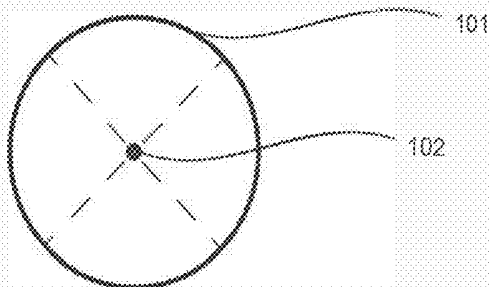

Fig. 1B

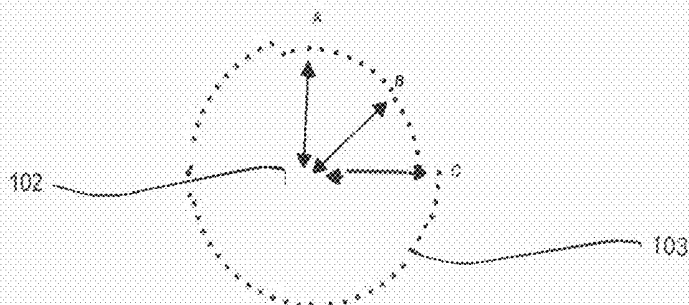

Fig. 1C

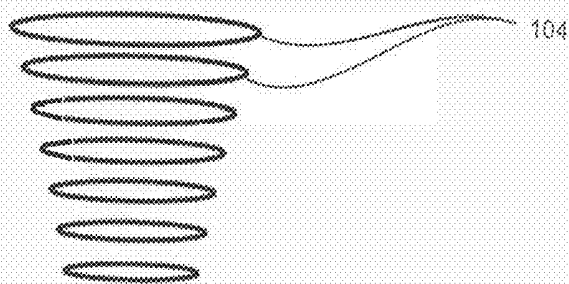

Fig. 1D

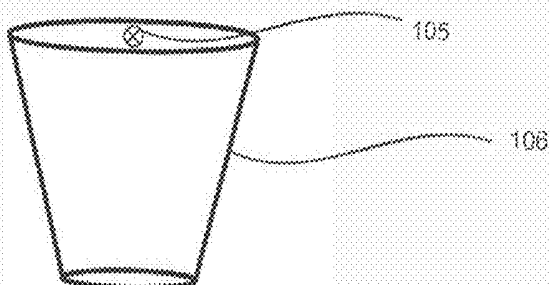

Fig. 1E

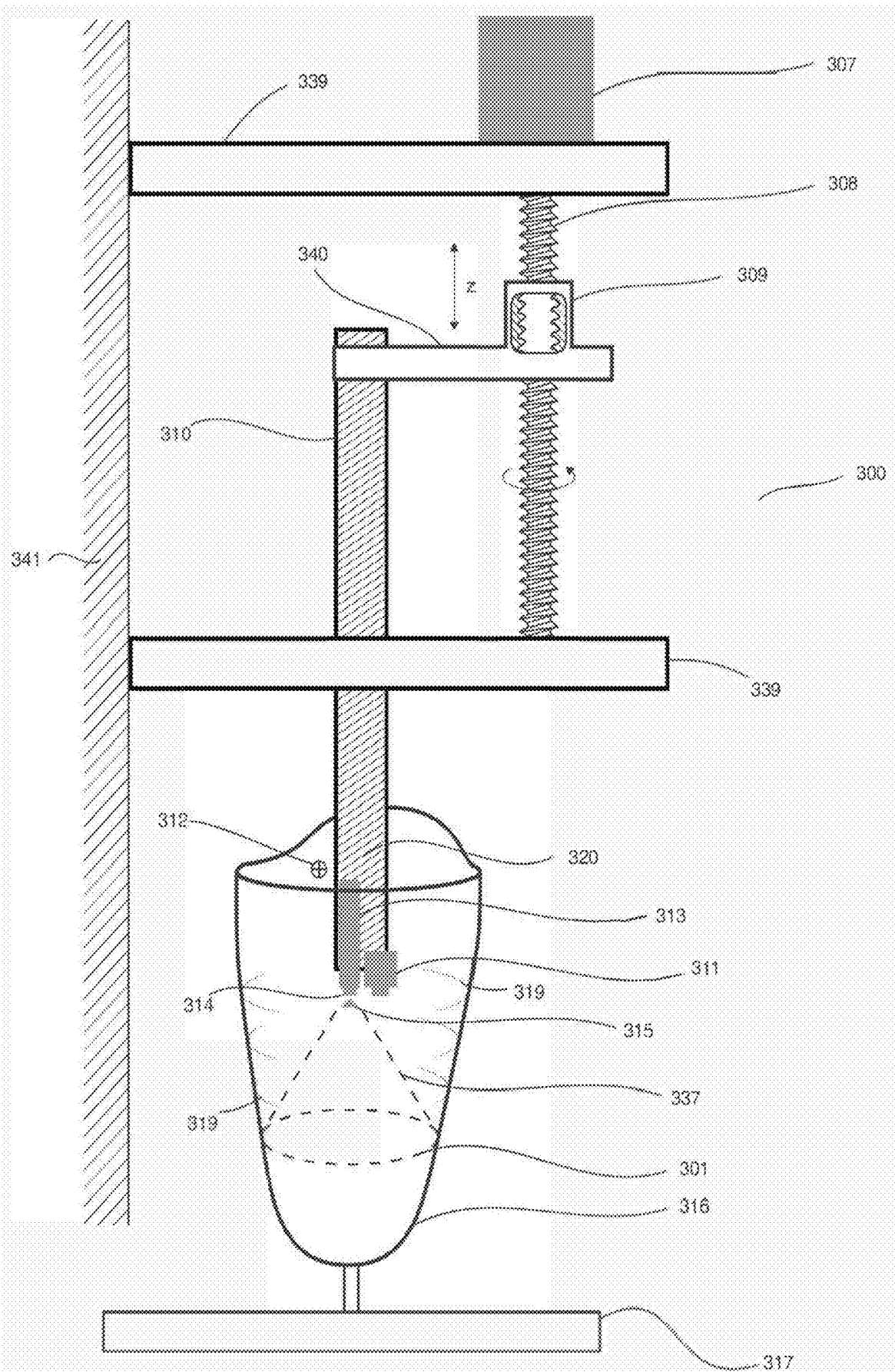

Fig. 3A

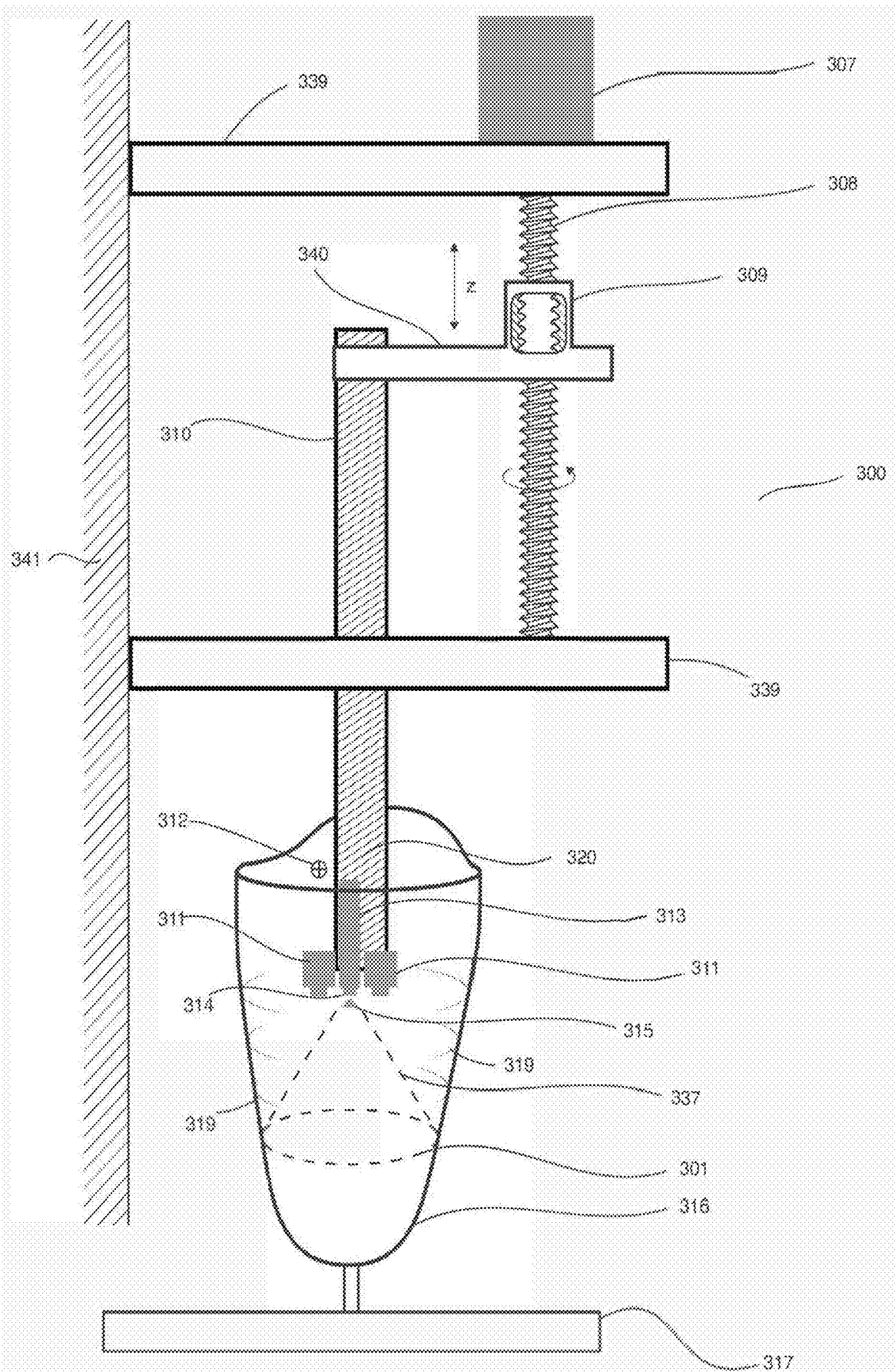

Fig. 3B

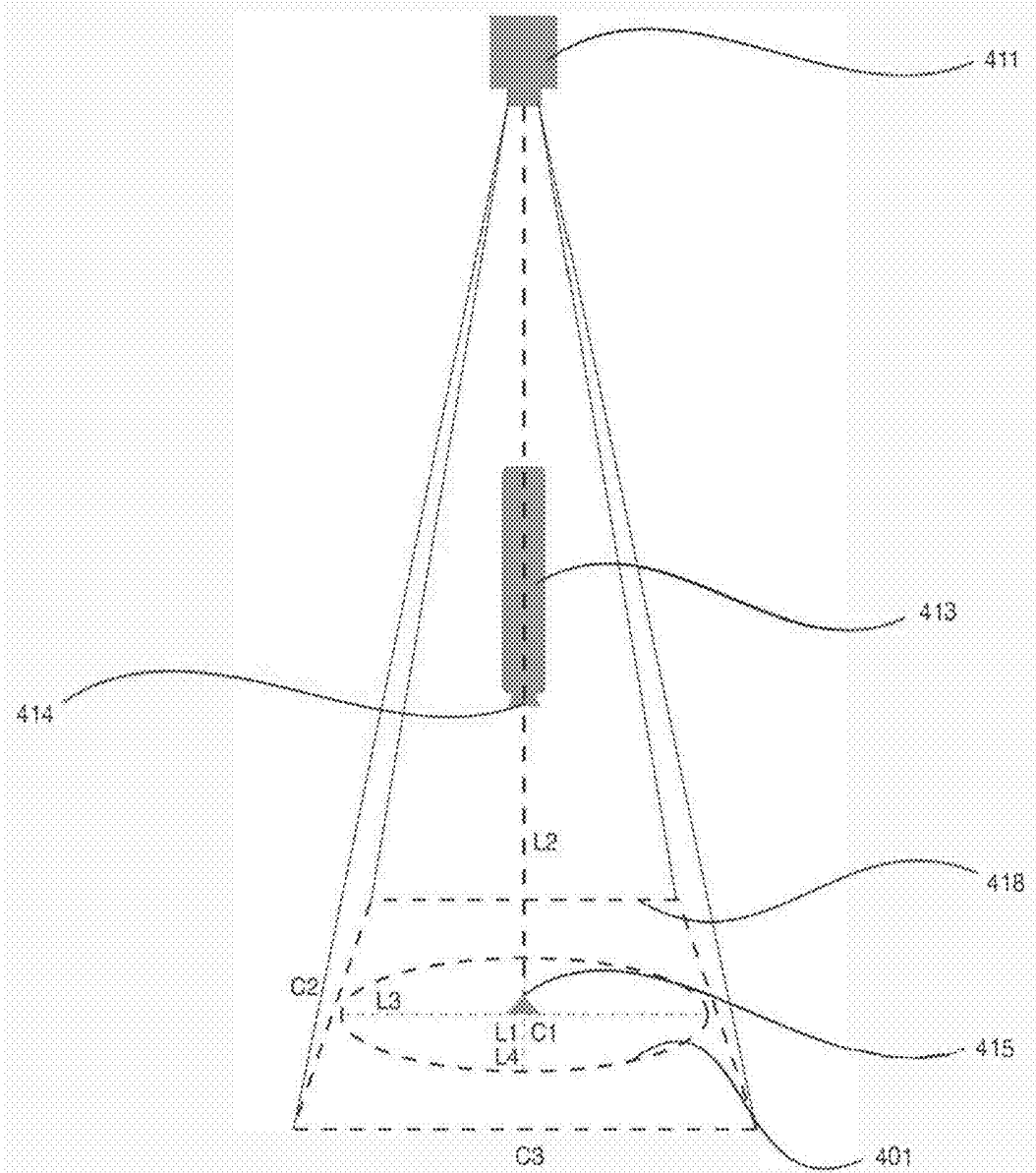

Fig. 4

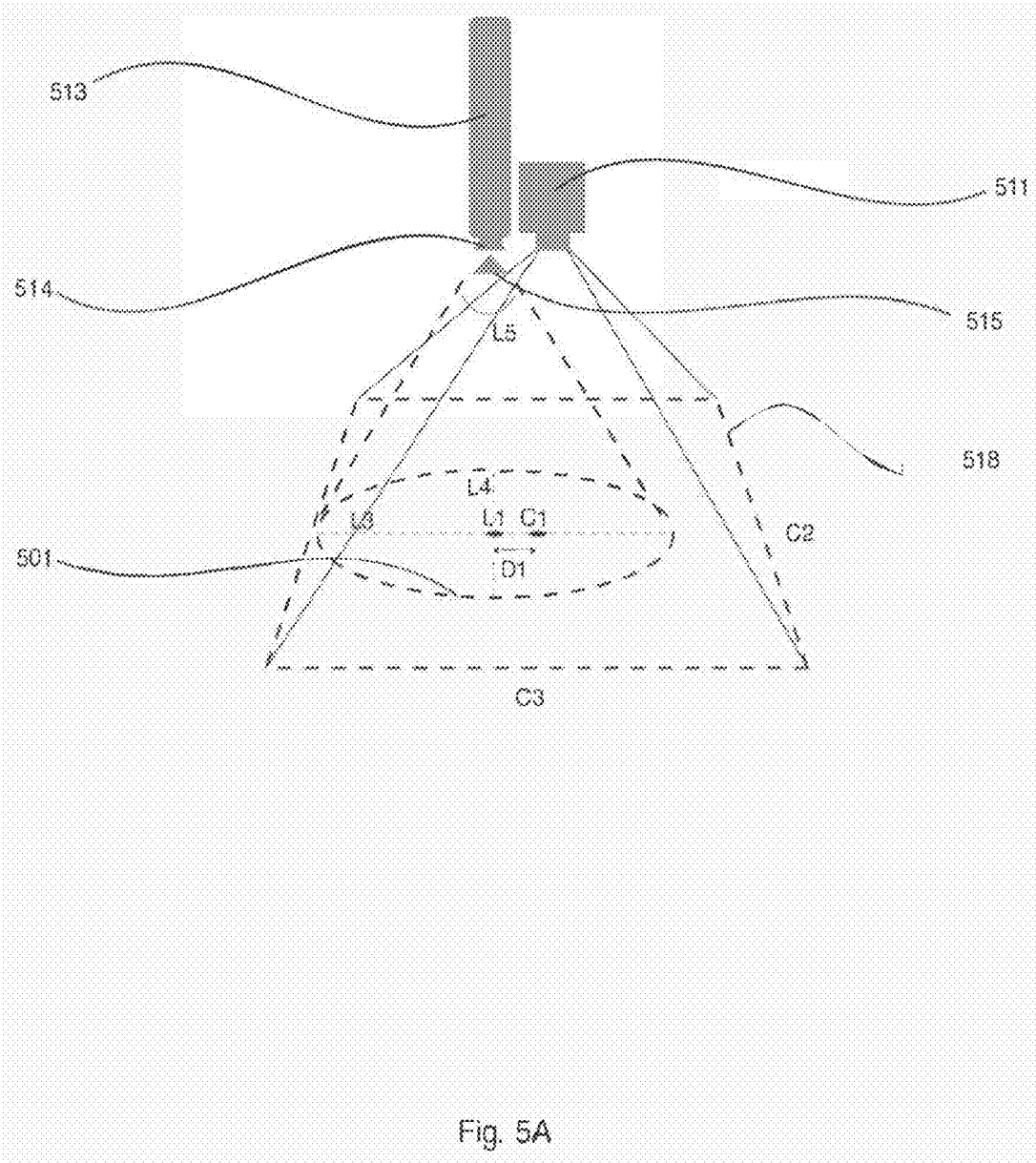
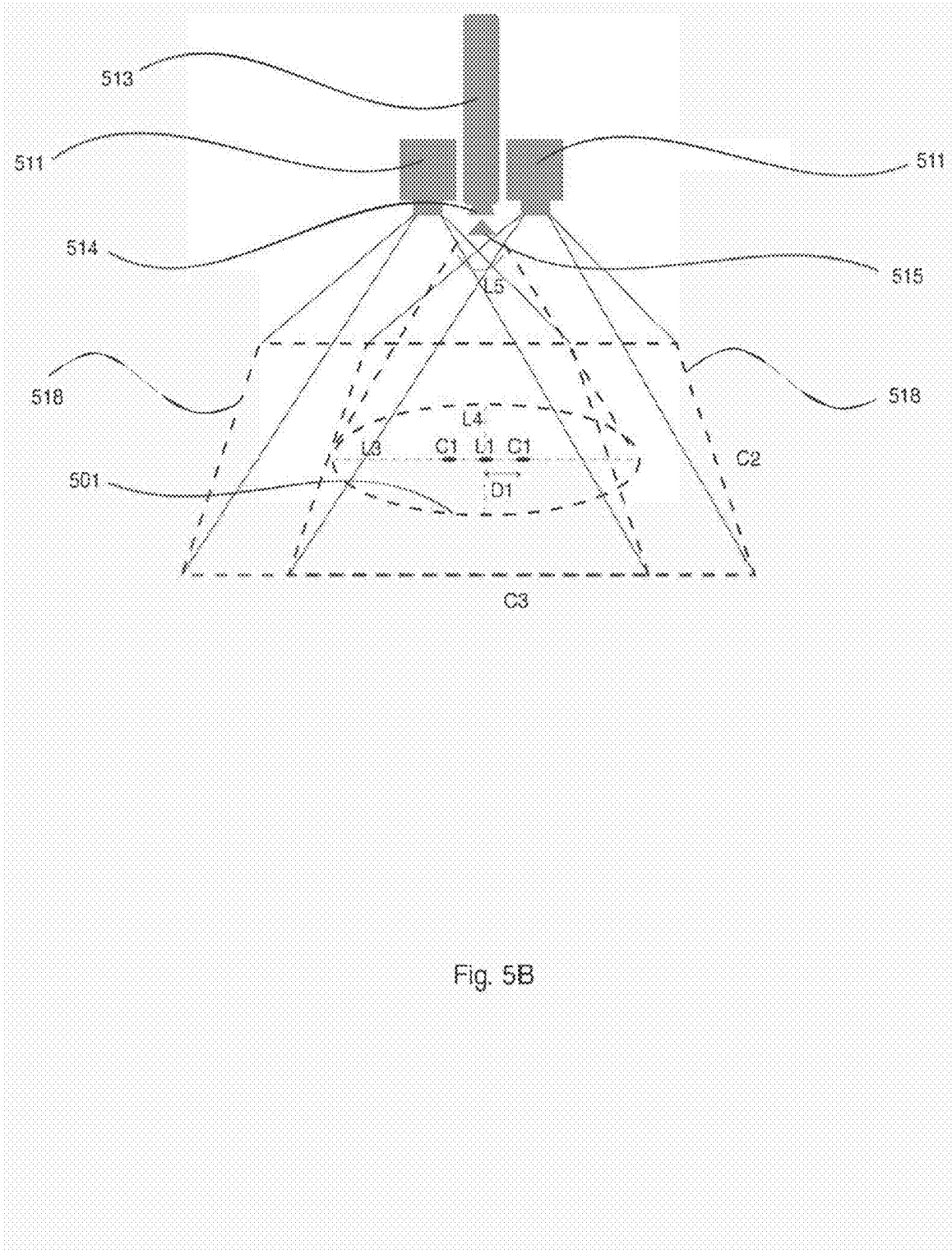

Fig. 5A



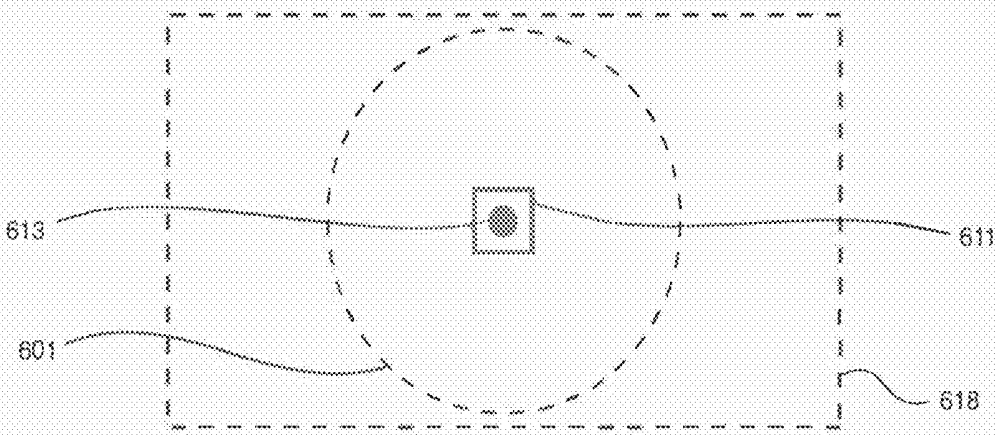

Fig. 6

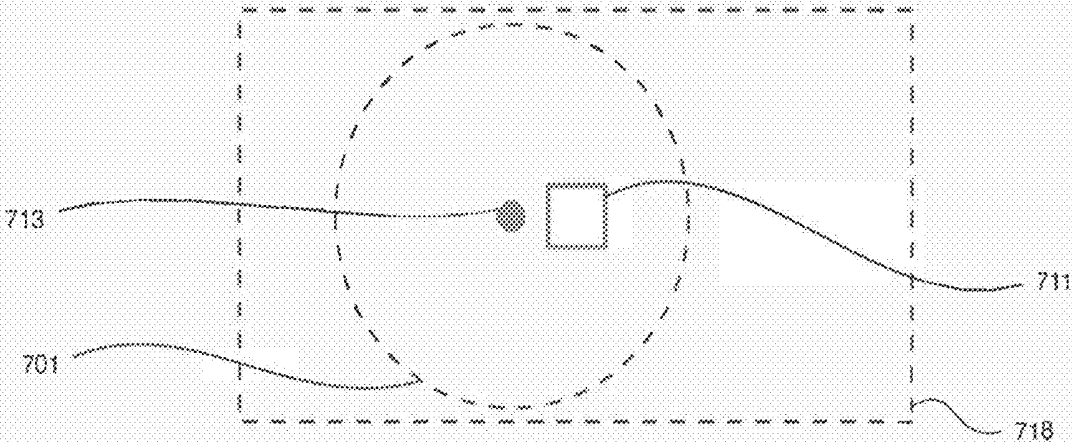

Fig. 7A

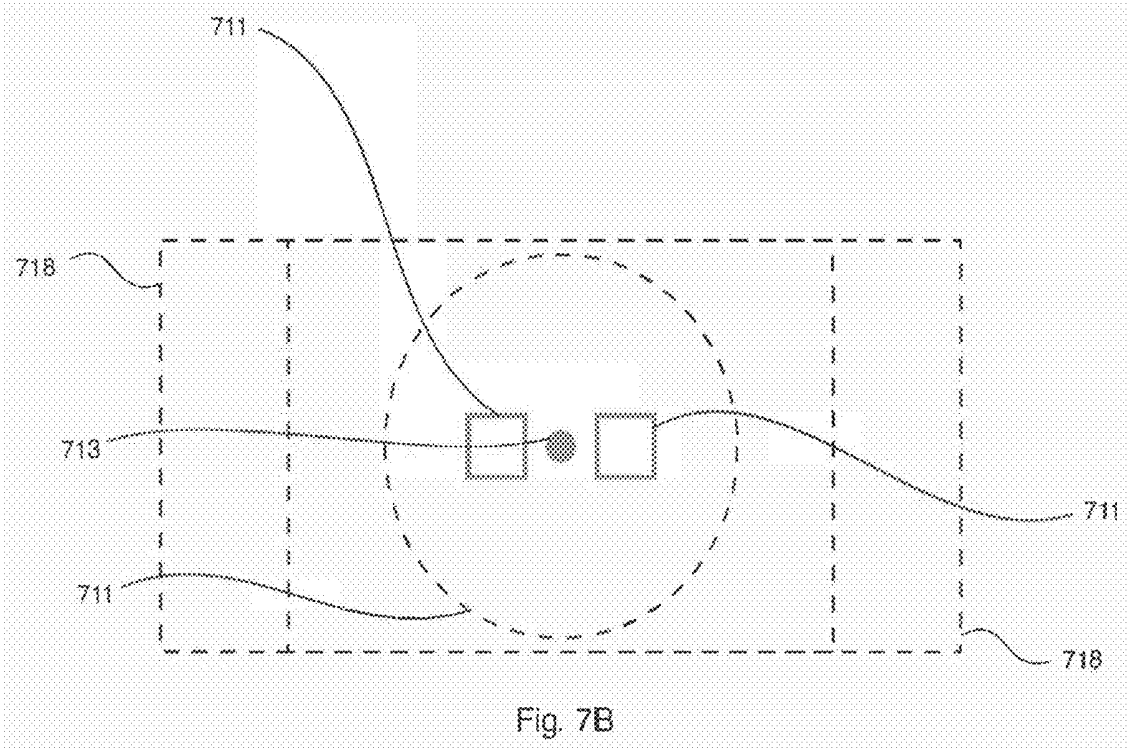

Fig. 7B

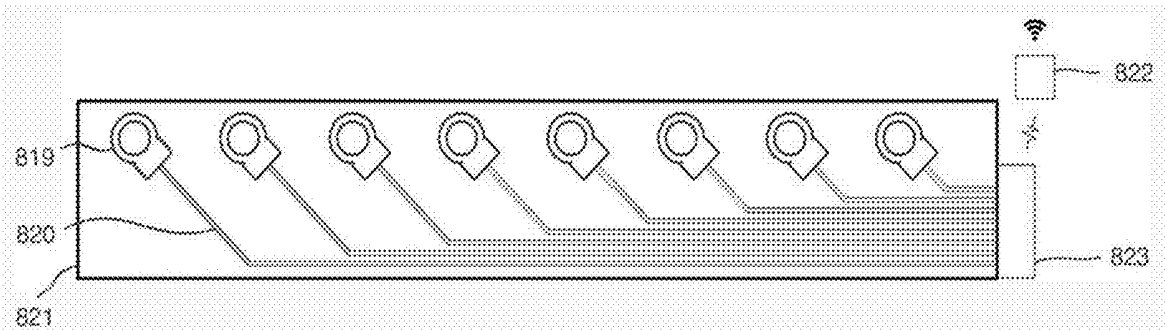

Fig. 8A

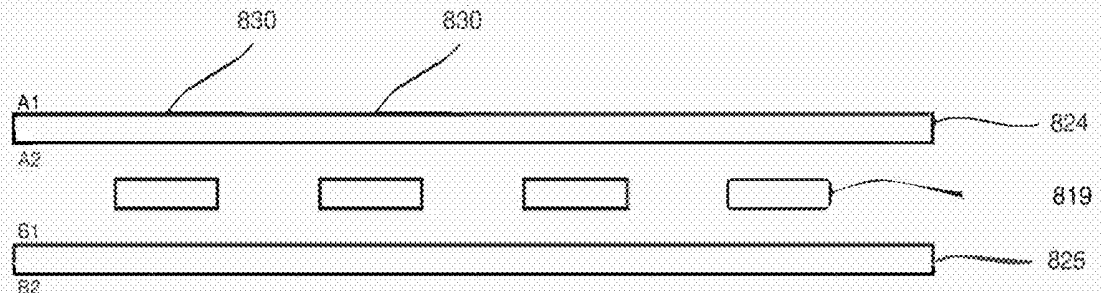

Fig. 8B

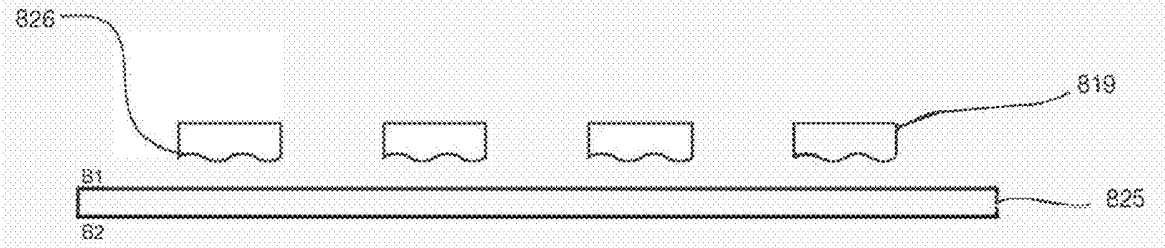

Fig. 8C

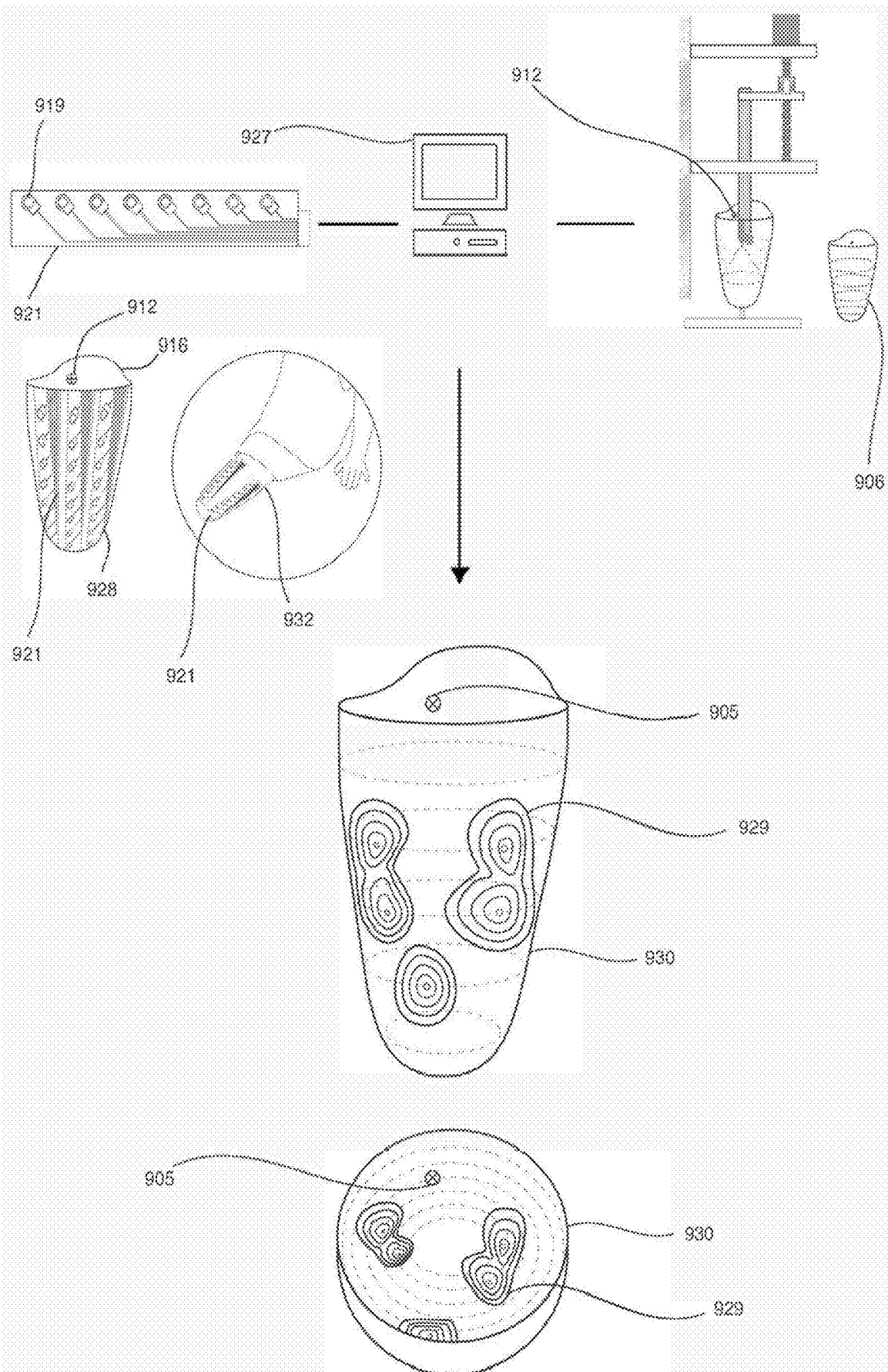

Fig. 9

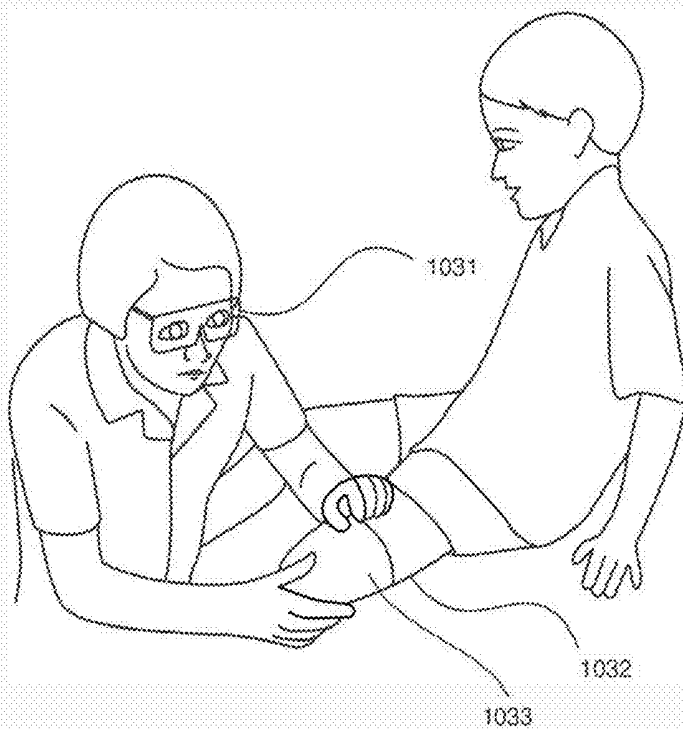

Fig. 10A

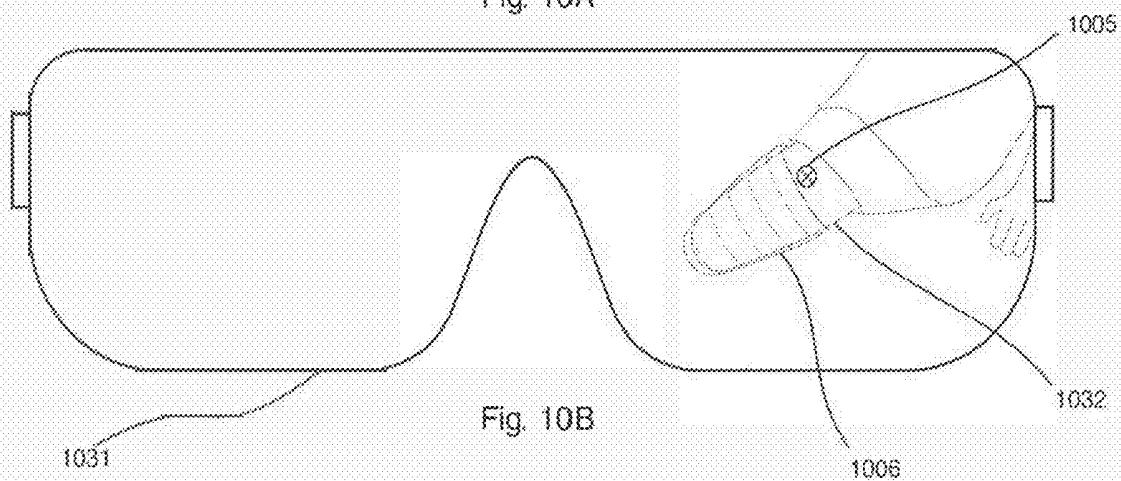

Fig. 10B

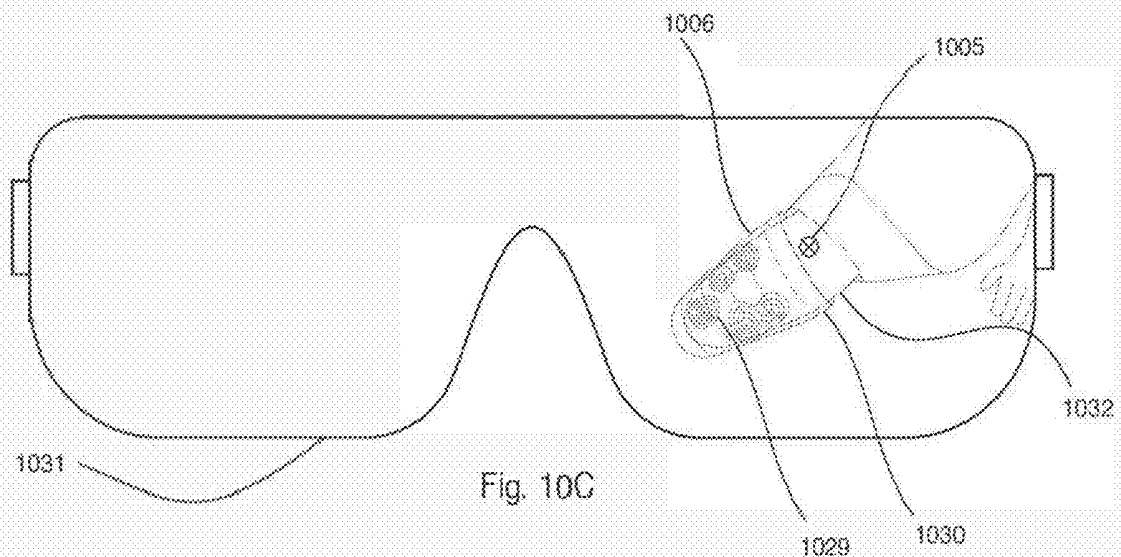

Fig. 10C

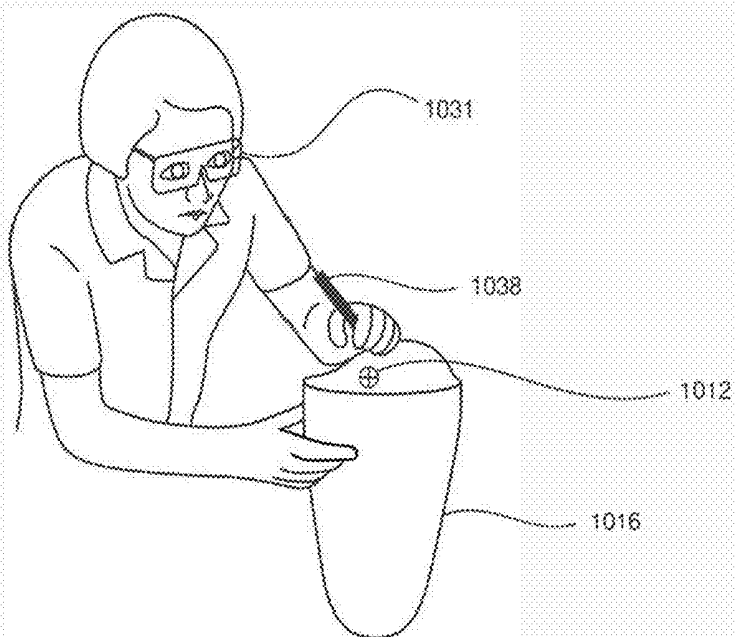

Fig. 10D

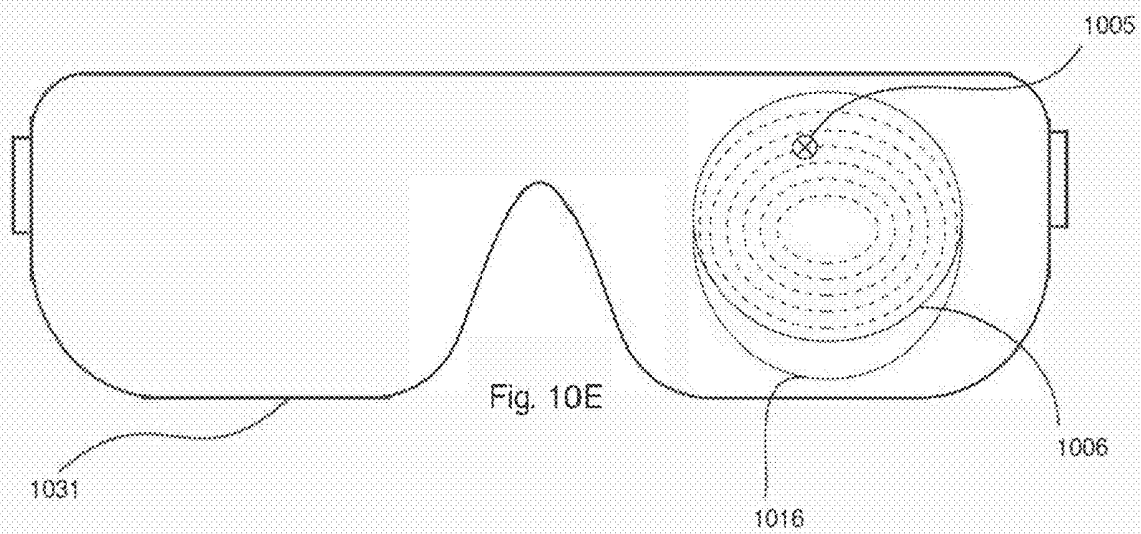

Fig. 10E

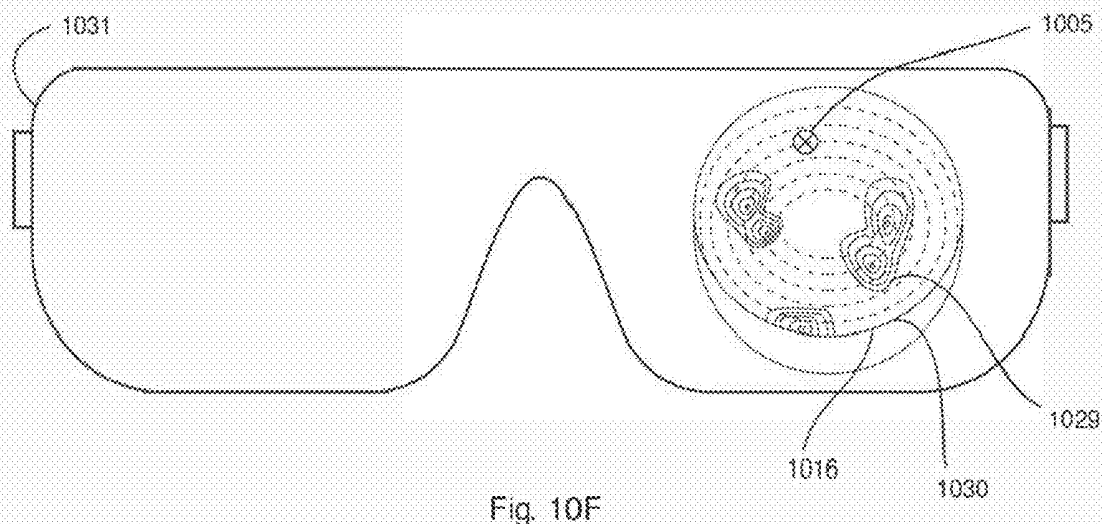

Fig. 10F

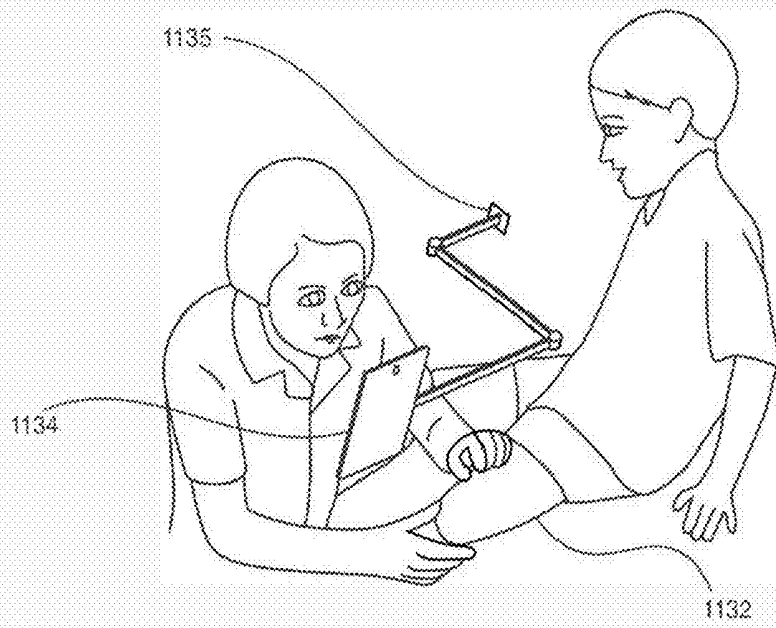

Fig. 11A

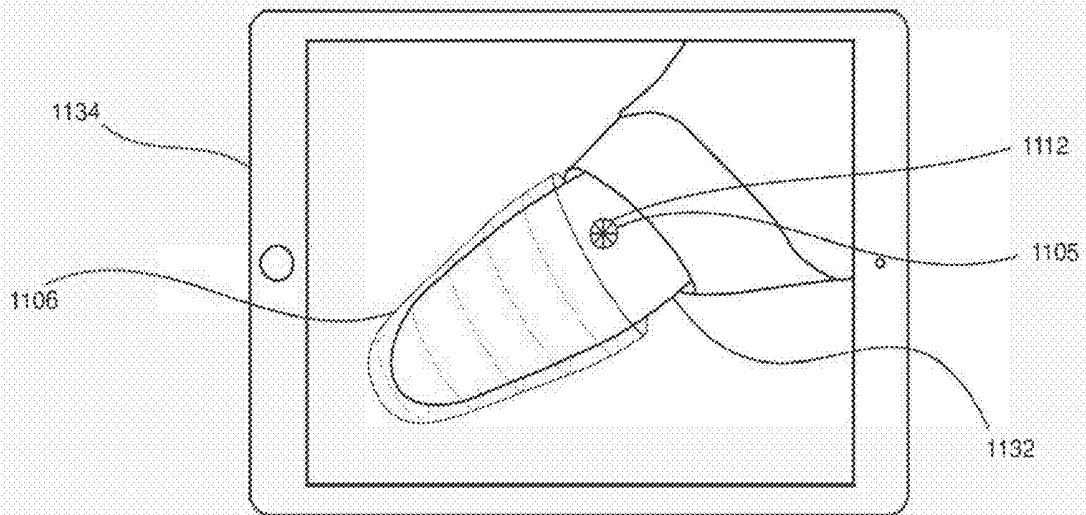

Fig. 11B

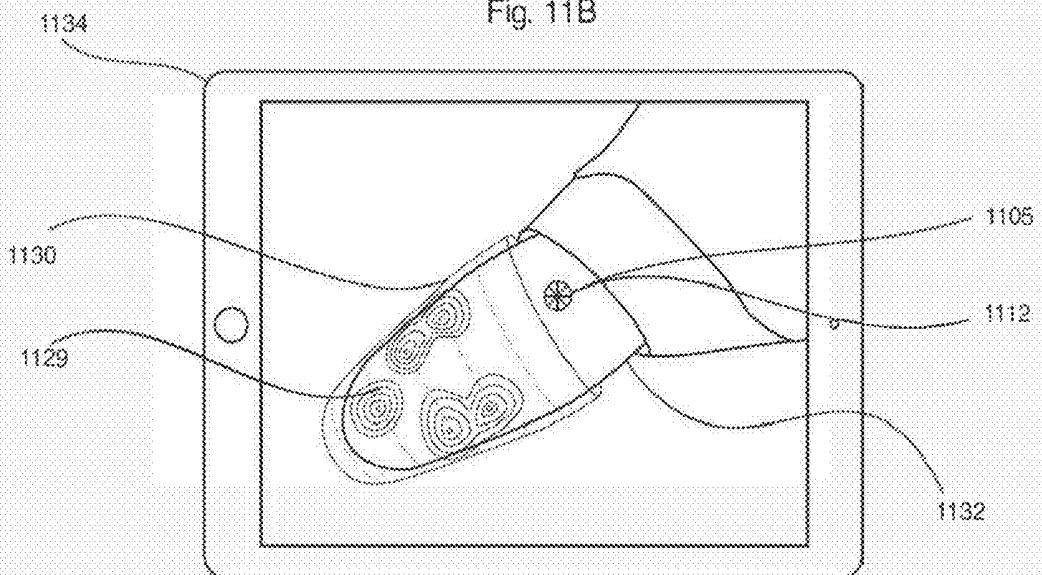

Fig. 11C

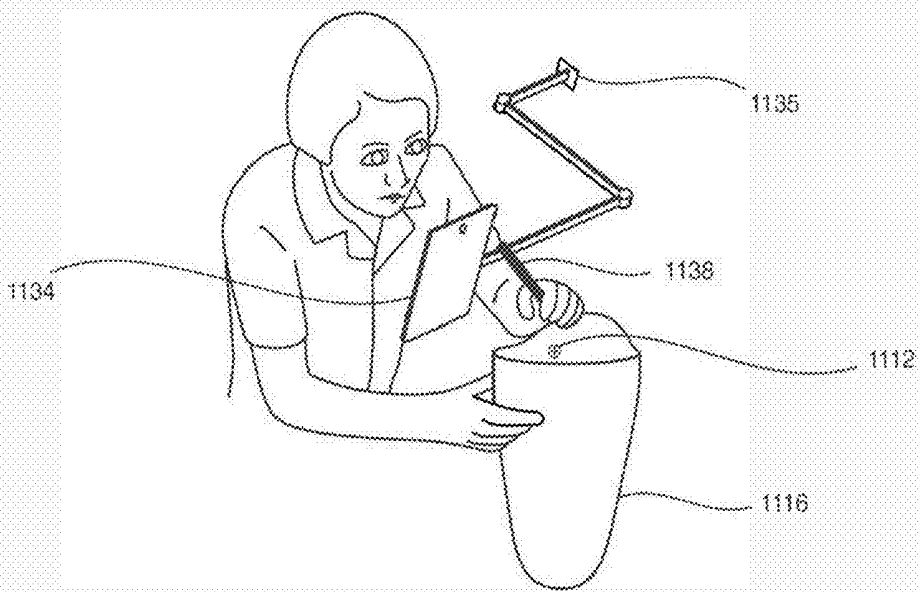

Fig. 11D

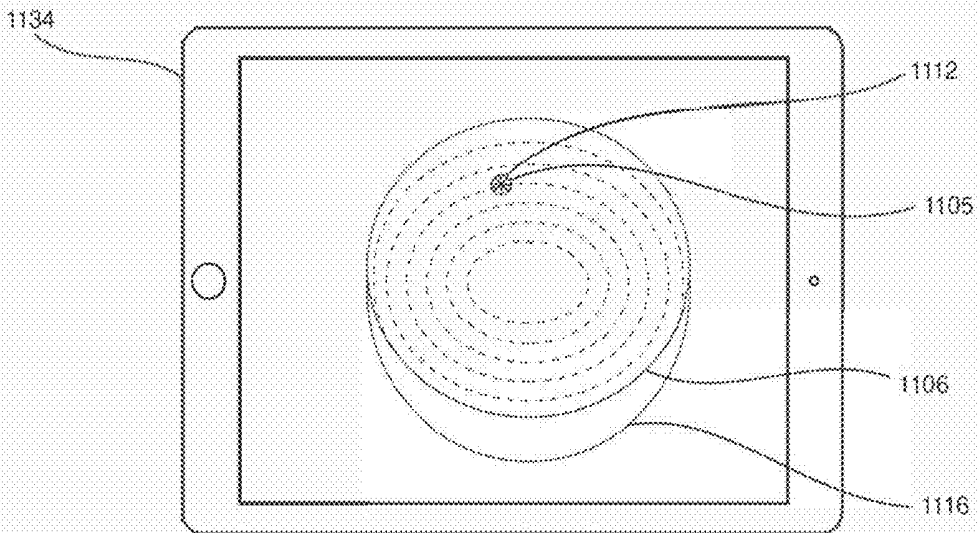

Fig. 11E

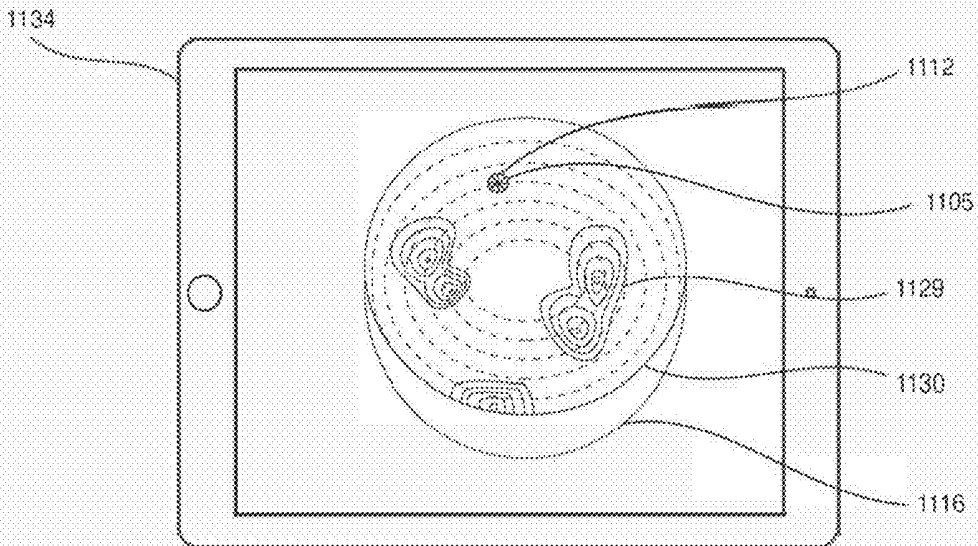

Fig. 11F

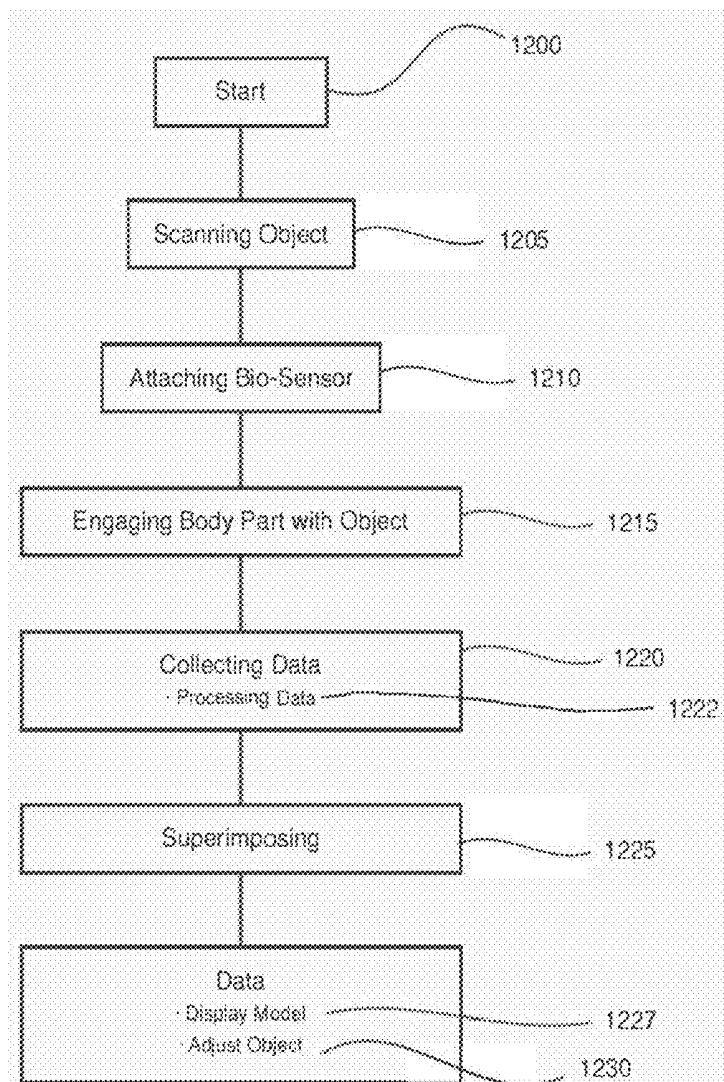

Fig. 12

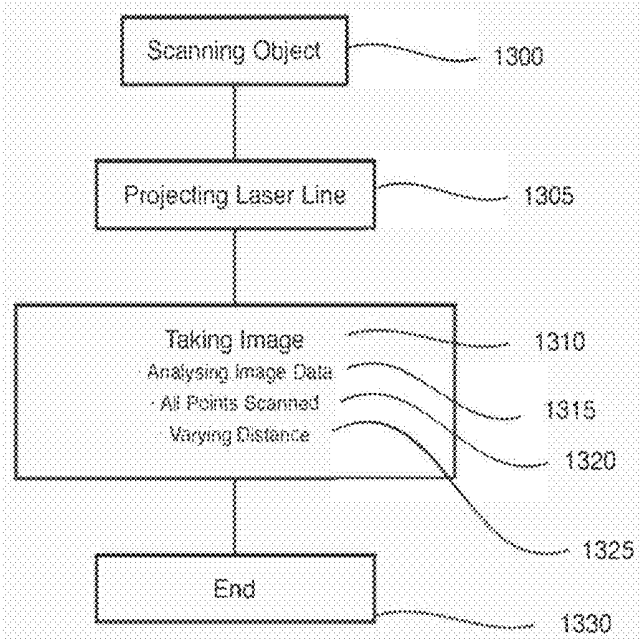

Fig. 13

FITTING SYSTEM

CROSS-REFERENCE TO RELATED APPLICATIONS

[0001] This application claims priority to and benefit of Luxembourg Patent Application No. LU 100021 filed on 13 Jan. 2017.

BACKGROUND OF THE INVENTION

Field of the Invention

[0002] The present invention relates to improvements in relations to systems, apparatus and methods of measuring and adapting objects for a comfortable engagement with an engaging member, and more particularly to systems, apparatus and methods of measuring, adapting and shaping an object to a body part to ensure a comfortable and functional fit between the object and the body part. Examples of the objects include prostheses and orthoses, for example the fitting of a prostheses to a stump of the residual limb of a wearer.

Description of the Related Art

[0003] The fitting and shaping of the socket of an artificial limb (prosthesis) to ensure that the artificial limb is an accurate fit with the stump of the residual limb with which the artificial limb engages is one of the most important parts of or in the formation of a prosthesis, and also one of the most difficult. The socket serves as an interface between the residual limb and the prosthesis, allowing comfortable weight bearing, movement, and balance. The socket therefore has to be shaped to be a perfect fit, with an adequate or desired surface bearing or loading to prevent painful points of contact. Pain and discomfort may occur from pressure, friction, temperature, or any other physical situation caused by an improperly fitted socket or a misaligned prosthesis. It will be appreciated that friction will lead to an increase in temperature and this can be measured by temperature sensors.

[0004] At the same time, the socket needs to be sufficiently tight so that during movement the prosthesis is firmly held in place and does not fall off or twist. The prosthesis also needs to be adjustable to take into account that the volume of the residual limb changes over time. For example, in the first few months after amputation, the stump of the residual limb will change in shape due to changes in fat and muscle distribution.

[0005] Currently, in order to make a new prosthesis to fit the stump, a mould of the stump is first taken, and the socket of the prosthesis is shaped according to the shape of the mould, and this shaping process is either manual or executed by a machine under computer control, or a combination of both. Once this rough shaping is completed, the shape of the socket is then fine-tuned, usually manually, to create a comfortable fit with the stump. However, prior art methods of fine-tuning of the shape of the socket to create a comfortable fit to a stump are laborious, empirical and time consuming. The shaping process relies fundamentally on verbal feedback from the wearer with regard to how the prosthesis feels, where the prosthesis is rubbing and the like. Small changes are then made, and the fit is tried again. Such communication is, however, often imprecise and very simple, with the patient simply indicating generally where

discomfort or pain is occurring on the stump. This is made more difficult by the fact that firstly, the nature of the pain or discomfort is that the pain or discomfort usually does not just occur at the point of contact but in an area around the point of contact, so that locating the issue point precisely is very difficult. Secondly, the patient may have to remove the stump from the socket in order to identify the pain point, and once so removed, the pain will tend to soften, again making it more difficult to accurately identify the actual contact point. Moreover, the trauma or the pathology that led to limb loss may itself have caused nerve displacement, so that the place where pain is felt (pain point) and the actual friction or pressure spot may be in two different locations, or have caused reduced sensitivity, so that the patient is unable to give precise information. Furthermore, the psychological trauma or indeed general reluctance of the patient to provide detailed feedback may lead to incorrect or imprecise information. The phenomenon of “phantom limb pain” is also known that will also affect the information provided to a fitting technician by the patient.

[0006] There is therefore a need for a system that is able to provide precise, objective and location-specific information about the fit between a residual limb stump and a prosthetic socket.

[0007] In an attempt to improve on the prior art approach, U.S. Published Patent Application No. 2014/0063220 discloses a photo-based fitting system in which the patient’s residual limb is photographed from many angles to provide a spatial image of the residual limb and to facilitate the design and construction of the prosthetic socket. However, this approach does not provide any information on the comfort of the fit between the stump and the socket once the socket has been formed, and really only provides an alternative to taking a mould of the stump for the rough forming of the socket. There is no teaching provided as to how to better fine tune to the fit between the stump and the socket.

[0008] Similarly, WO 2014/036029 discloses a view-finder-based system for acquiring data on the stump for which a prosthetics socket needs to be built, but again this does not provide any teaching regarding the fine tuning of the socket to ensure a comfortable fit. It should also be noted that in both cases, the information provided is static and refers to a moment in time, when the photograph was taken and ignores any dynamic data produced during actual continued use of the prosthesis.

[0009] U.S. Pat. No. 8,784,340 discloses a further solution to the problem of fitting a prosthetic limb in which a liner is fitted over the stump, the liner having a plurality of pressure sensors embedded therein which are connected to a data acquisition system. However, this solution does not provide any teaching as to how the technician can use the collected data to improve the shape of the socket as the pressure sensors does not provide any precise spatial information which can be used to correlate the pressure data with the shape of the socket. This is made worse by the fact that the liner is fitted to the stump, so at least the liner could only provide information on the shape of the stump rather than the socket, and in any event, due to the nature of the liner and its imprecise fitting, the exact location of the sensors on the stump cannot be ascertained in that system. Finally, in the absence of any adhesive layer or securing mechanism, the liner cannot be prevented from continuously moving, thereby providing incorrect data.

[0010] Similarly, U.S. Pat. No. 5,993,400 teaches an apparatus and method for monitoring pressure between the surface of a body part (residual limb) and a contact surface on, for example, a prosthetic socket, a bed or a wheelchair. This apparatus and method employ a plurality of pressure sensors disposed in a matrix array between the contact surface and the body part. The sensors produce analog force signals proportional to pressure, and a monitor receives the analog signals and produces output signals, preferably digital, having pressure data corresponding to the pressure at each sensor. A computer processor receives the output signals from the monitor to create a force profile for the sensor array. The sensors may be scanned as a read event in variety of manners, including periodic, continuous, and triggered scanning. This monitoring apparatus and method is used, for example, to fit prosthetics, to monitor bed-ridden and wheelchair-bound patients, to reduce pain and sores caused by uneven distribution of pressure and to monitor pressure between a cast and a person. The sensors may be mounted on a single sheet or on strips for positioning along the body, and monitoring is accomplished by multiplexing and digitizing the analog force signals.

[0011] A number of patent documents are known that teach the design and manufacture of prosthetic sockets using computer aided design. For example, International Patent Application No. WO 2012/083030 teaches above knee (AK) and below the knee (BK) prosthetic sockets and specific manufacturing processes for the production of prosthetic sockets through the automated, computer controlled bi-axial and tri-axial braiding of sockets, over a mold or mandrel made of carved foam, plaster material or wax that is a replica of the patient's truncated limb, and is created by a Computer Aided Design (CAD) file controlling a Numerically Controlled (CNC) machine tool. The prosthetic sockets are manufactured using fibers such as graphite or Kevlar, and high-performance resins, and create a socket which is stronger and lighter weight than conventionally manufactured sockets. Braiding also allows incorporation of woven cloth, tapes and other reinforcements into the braiding process for added strength at selected areas.

[0012] U.S. Published Patent Application No. 2010/0023149 teaches a method for evaluating prosthetic sockets (and other objects) which are designed and fabricated with computer aided design and manufacturing software. The shape of the prosthetic socket is accurately scanned and digitized. The scanned data are then compared to either an electronic shape data file, or to the shape of another socket, a positive model of a residual limb (or socket), or a residual limb. Any differences detected during the comparison can then be applied to revise the design or fabrication of the socket, to more accurately achieve a desired shape that properly fits the residual limb of a patient and can be used to solve the inverse problem by correcting for observed errors of a specific fabricator before the prosthetic socket is produced. The digitizing process is implemented using a stylus ball that contacts a surface of the socket to produce data indicating the three-dimensional shape of the socket.

SUMMARY OF THE INVENTION

[0013] There is accordingly a need for a system and method for improving the fine tuning of the shape of the socket to fit the stump by providing precise information on the mismatching between the shape of the socket and the shape of the stump. More generally, the system and method

can be used for identifying difference in shape, load and biosensor profile distribution, as well as the physical characteristics between an object and a body part, i.e. part of a human body, which is engageable with the object.

[0014] According to a first aspect of the present invention, there is provided a method of identifying the differences in shape and physical contact characteristics between the object and the body part which is engageable in the object, comprising the steps of scanning the object with a radiation source, such as, but not limited to, a laser, in order to produce a surface map of the object, attaching a plurality of bio-sensors to a surface of the object at locations which are known relative to a reference point, engaging the body part in the object, collecting data from the bio-sensors to record information on the engagement between the body part and the object over the surface of the object, and superimposing the data from the bio-sensors over the surface map of the interior of the object in order to identify areas of the object which need to be adjusted in order to improve the fit of the body part in the object.

[0015] The present invention further comprises an apparatus for identifying the differences in shape and physical contact characteristics at an interface between an object and a body part which is engageable in the object, comprising a conical laser assembly and a capturing element for scanning the surface of the object in order to produce a surface map thereof, an adjuster for varying the distance of the laser from the surface, a plurality of bio-sensors attachable to the surface of the object at locations which are known relative to a reference point, data collecting means connected to the bio-sensors for collecting contact data from the plurality of the bio-sensors, processing means for superimposing the bio-sensor data onto the surface map to produce a bio-data profile of the object, and a display for displaying the bio-data profile to a technician.

[0016] It will be noted that the bio-sensors may also be attached to the body part but what is important is that they are firmly positioned and held in place between the object and the body part.

[0017] Bio-sensors can be of different types and include, but not limited to, one or more of pressure sensors, temperature sensor, accelerometers, magnetometers, pedometers, galvanic response sensors, humidity sensors, air flow sensors, electromyography sensors, electrocardiography sensors, oximetry sensors and mechanomyography sensors. Preferably the sensors include a plurality of pressure and temperature sensors. The pressure sensors measure forces at the normal to the surface of the body part, whilst the temperature sensors indicate friction between the body part and the object due to transverse forces along the surface of the body part.

[0018] The body parts can be, for example, a stump of an amputated limb, a limb, a bottom sitting on a wheelchair, a back lying on a bed. The objects are in these examples a socket for a prosthesis, an orthotic element, e.g. knee brace, a wheelchair, or a bed. It will be appreciated that the invention has other applications.

[0019] A method and apparatus according to the invention has the advantage that by mapping the bio-data onto the socket surface map, the prosthesis fitting technician is provided with an accurate guide of where issues exist at the interface between the stump and the socket, and therefore makes identification of the regions of the socket which need adapting, rectifying, tuning or shaping and the amount

required thereof much easier. As a result, the number of iterations to achieve a good fit is reduced resulting in a shorter, more efficient, and more economic prosthesis fitting process. The method and apparatus of the present invention reduce the cost of fitting a new or replacement prosthetic socket, as well as for adjusting existing prosthetic sockets, and achieve comfort for the patient much more quickly.

[0020] In a particularly preferred embodiment, a plurality of temperature and pressure sensors are provided on the socket surface for collecting both temperature and pressure data relating to the engagement between the socket and the stump. The use of both temperature and pressure sensors in the stump allows an improved understanding of the engagement between the stump and the socket to be formed, the temperature sensors providing not only biometric information relating to the surface of the stump but also allows temperature compensation of the pressure readings to be carried out, thereby improving their accuracy, as well as other benefits such as obtaining information about sensitive spots which are prone to ulcers and injury.

[0021] The sensors may be attached individually to the socket, it being important primarily that the exact location of each sensor in the socket, relative to a reference point, is known. Preferably, however, the sensors are provided in strips or arrays, so that they may be applied to the surface of the socket in a fixed relation to each other. This has the advantage of making the application process quicker whilst at the same time ensuring accurate spacing. Furthermore, by providing the sensors in strips rather than in a web or net, the spacing between the strips can be varied to control the density of the monitoring, so that high resolution monitoring can be carried out in areas of greater interest, namely with respect to pressure or temperature variation. An appropriate pattern of sensors on or in the strip may be used, such as alternating between pressure and temperature sensors, or indeed any other bio-sensor capable of sensing and measuring a physiological or physical variable of interest.

[0022] The radiation source is preferably a conical laser assembly which comprises a laser and an optical element which converts the single laser beam into a two-dimensional laser array. In one embodiment, the laser may be of the type which is made by Coherent of Wilsonville, USA, and sold under part number M203450073, and the optical element is a conical mirror such as that made by Edmund Optics Inc., of Birmingham, USA and sold under model number R5000095826-14015. By focusing the laser beam on the vertex of the conical mirror, the laser beam is converted into a laser line projected from the plane of the base of the conical mirror. This arrangement has the advantage of keeping a fixed distance between the laser and the conical mirror projecting the laser plane at 90 degrees, such that the distance between the plane of the laser and a capturing element is always known, thereby allowing a stable calibration rule capable of accurately converting pixels to millimetres. This calibration makes it easier to get the real dimensions of the analysed object, but it requires a very precise alignment between the two elements in order to obtain the best results. Such precise alignment is costly to achieve and may also become altered under the everyday-use conditions of a prosthesis clinic, thereby requiring frequent and costly calibration.

[0023] In an alternative embodiment, the optical element in the conical laser assembly is a diffractive optical element which converts the laser beam or dot into a variety of

patterns, including a conical shape which produces a solid (substantially circular or elliptical) projected laser line with a certain aperture angle. A suitable laser and laser head is made by Laser Components, from Olching Germany and sold under model numbers FP-DOE-520-3-P-268-F300 and FP-DOE-635-3-P-268-F150. This embodiment has the advantage that it is much easier to use and requires less space to mount. However, it requires a dynamic calibration rule to be able to know the real dimensions of the analysed object, because the distance of the projected laser line plane will depend on the diameter of the scanned object.

[0024] The laser is used in conjunction with a capturing element, for example one or more cameras, which detect and segment the laser on the surface of the socket and accurately measure the distance between the capturing element and each point on the surface. The capturing element is preferably arranged in a fixed position relative to the laser, the distance from the laser being known. The relative position between the source and the capturing element is known and therefore the distance and direction to each point on the surface can be accurately calculated and mapped.

[0025] In order to scan the surface of the object, the laser, the conical laser assembly and the capturing element(s) are moved as a single unit towards and away from the surface of the scanned object (i.e. the socket) in order to change the projection of the laser on the surface. This movement changes the part of the surface which is being illuminated, in the case of the prosthetic the projection of the (substantially circular or elliptical) laser line or pattern on the inner surface, and therefore the area that is analysed by the capturing element. The movement is varied to enable the whole surface of the scanned object to be mapped.

[0026] The projected laser line or pattern of laser light is projected onto the surface of the scanned object with the laser at a first distance from that surface. If any deviations in the height of the surface, however, either in the form of recesses or projections, will cause the distance of the affected points from the laser to change and hence, due to the divergence of the laser, will cause distortions in the circular/elliptical form of the projected laser line. Raised portions on the surface will cause distortions inwards towards the inner portion of the projected laser line and recessed points will cause distortions outwards of the projected laser line.

[0027] By knowing the resolution of the capturing element, after segmenting the projected laser line in the image acquired (intersection of the laser plane with the surface of the object) and detecting a reference point of this projected laser line, it is possible to know the distance in pixels between each point of the projected laser line and a reference point, as is described in more detail below. The reference point could be, for example, a central point if the projected laser line is substantially circular. By determining the distance between the camera and the plane of the projected laser line it is possible to establish a correlation between the virtual dimension in pixels and the real dimension in millimetres. By computing the distance between each pixel of the laser line, and the reference point of the projected laser line, it is possible to obtain the position of each point of the projected laser line which is projected on, and therefore corresponds to, a point on the surface of the socket. After the system calibration (to infer the real position of the points), by joining the information resulting from the analysis of all

the images acquired in the x and y dimensions along the z axis it is possible to reconstruct the 3D model of the scanned object, such as the socket.

[0028] The apparatus of the invention is capable of fully scanning an internal cylinder with 50 cm height in 30 to 60 seconds. This is a significant improvement of 4 (Rodin4D ECHO) to 20 (Coordinate Measuring Machines—CMM) times faster regarding other solutions available, when considering the same resolution. Furthermore, the apparatus presents a lower complexity, using only one axis of movement to achieve an equivalent resolution to other solutions designed for the same purpose. Only CMM machines of very high complexity are able to reach a higher precision but require a much longer scanning time.

[0029] The bio-sensors used in the present system collect bio-data from the prosthesis socket in use. The bio-sensors are thin, preferably less than 1 mm in thickness so that they themselves do not become a source of discomfort for the user and have an impact on data acquisition. Suitable models are available from Interlink Electronics Inc. of California, USA, reference FSR400. This particular model can measure applied force from 0.2N to 20 N and is particularly suited to pressure determination between the stump and the socket. In addition, these bio-sensors can measure resistances from 45Ω to $45\text{ M}\Omega$ and vary proportionally according to the force applied over the sensing area (19.635 mm^2 approximately). Other useful models include FSR400 Short from Interlink Electronics or HD-001 from IEE in Luxembourg.

[0030] Bio-sensors can also be temperature sensors, they too are mechanical transducers and are named Thermistors. Useful thermistor resistances range from $0.4\text{ k}\Omega$ to $400\text{ k}\Omega$ and they vary according to the temperature to which they are exposed. Suitable sensors such as NTC JT Thermistors, specifically 103 JT-025 are produced by Semitec USA Corp (California, USA).

[0031] Depending on the variable of interest, different type of sensors may be used. The preferred embodiment includes a sandwich-type construction, the sensors being placed between two layers of material, which can be made of any suitable polymer, flexible, thin film and be delivered in rolls. There can be one plastic film A comprising two sides A1 and A2, which can be coated with a bio-compatible material on side A1 which will be in contact with the stump skin or a liner and which can be coated with an adhesive material on side A2 which will receive the sensors, as well as the power and data leads thereof and hold them in place. There can be another plastic film B also comprising two sides B1 and B2, which can be optionally coated with an adhesive material on side B1. Side B1 is intended to fit exactly over side A2 of strip A and thereby sandwich the sensors and leads, and side B2 can be coated with an adhesive material or be composed of an adhesive material and it will be applied and adhere to the socket.

[0032] This is in the case of the sensors being applied and adhering to the socket. Other variations of the sensors may be built so that they adhere to the stump or the liner and surface finishes shall be modified to that end.

[0033] Plastic film rolls A and B are substantially of the same width or about 1.5 cm to 4 cm and several metres in length, for economic manufacturing; they can be cut later to proper length before use. They can be produced in a high-speed, continuous assembly line which will dispense and place the sensors and power and data leads onto side A2 of film roll A. The assembly line will then dispense and

precisely place side B1 of film roll B over side A2 of film roll A and press the two films together so as to create a strip of sandwiched sensors and leads. The continuous sensor strip is then cut at appropriate lengths ranging from about 10 cm to 50 cm to produce individual sensor strips for use. Individual sensor strips, comprising one or more individual bio-sensors **819, 919**, are then each fitted with a power and data interface device which is glued, clamped or soldered at one of the extremities of the sensor strip to connect with the power and data leads of the sensor, so as to provide power to the sensors and acquire data from them.

[0034] It should be noted that the arrangement and combination of surfaces and finishes described above for all four sides of plastic film rolls A and B is not mandatory and that other constructions may be used, provided the bio-sensors **819, 919** sensors are adequately held in place. Indeed, in a further embodiment the sensor strip could comprise a single plastic film strip, and the sensors and the leads could be treated with an adhesive finish on one side so that proper adhesion to the plastic film would be ensured by the sensors and leads themselves. In this construction, the side of the plastic film facing the socket would have an adhesive finish and the other side facing the stump or liner would have bio-compatible properties. The adhesive is “weak” so that the bio-sensor strip can be removed from one object and re-used on another object. Processes to manufacture bio-sensors in strips or in rolls is achievable through existing know-how and equipment to the persons skilled in the art.

[0035] In the fields of science, engineering and statistics, the accuracy of a measurement system is the degree of closeness of measurements of a quantity to that quantity's true value. The precision of a measurement system, related to reproducibility and repeatability, is the degree to which repeated measurements under unchanged conditions show the same results. Measurement resolution is the smallest change in the underlying physical quantity that produces a response in the measurement. In the present case, the measuring resolution of the system is directly related to the camera resolution, the movement resolution, (itself dependent on the motor step and the screw resolution), and the thickness of the projected laser line. The higher the camera and the movement resolutions, and the lower the thickness of the projected laser line, the higher the system resolution as a whole will be.

[0036] According to a still further aspect of the present invention, there is provided an apparatus for mapping a three dimensional surface comprising a laser, an optical element located in front of the element through which the beam of the laser passes so as to convert the laser point into the projected laser line when projected onto a surface, a capturing device located in a fixed and known position relative to the laser, means for varying the distance of the laser and capturing element from the surface of the scanned object in order to vary the size of the laser beam and the projected laser line and hence vary the part of the surface illuminated thereby, and processing means for analysing the data from the capturing means in order to determine, in use, the distance between the capturing means and the plane of the projected laser line. This then allows to establish a correlation between the virtual dimension in pixels and the real dimensions in millimetres and thereby generate a three-dimensional map of the surface of the scanned object.

[0037] The present invention still further provides a method of mapping a three dimension surface comprising

the steps of directing a beam from a radiation source, such as, but not limited to, a laser, through an optical element in order to produce a solid substantially circular projected radiation line or pattern, e.g. cone, on the surface of a scanned object, viewing the surface with one or more capturing elements, such as a camera, which is located in a fixed and known position relative to the radiation source, using the capturing element to measure the distance in pixels between each point of the projected radiation pattern and the reference point, repeating the measurement at different distances of the laser from the surface so that different points on the surface are illuminated until the complete surface has been measured to the required resolution, computing the distance between each pixel of the projected radiation and the reference point in order to obtain the position of each point of the projected radiation, using calibration data in order to convert the measurements in pixels into actual distance measurements, and collating the data collected at the different distances of the radiation light from the surface in order to locate the position of the bio-sensors and to produce a 3D model of the surface of the scanned object.

[0038] Preferably, the surface model generated according to any aspect of the invention is displayed to a user such as a prosthesis technician using a three-dimensional display system such as a virtual reality headset, an augmented reality mobile device or the like. Advantageously, the surface may have projected on the display a grid which is calibrated to the socket surface map generated by a computer from the projected laser light and camera(s) data, so as to enable a user easily to correlate the actual surface of the scanned object with the computer-calculated virtual surface and hence easily identify on the real surface the areas which need to be improved, adjusted, tuned or shaped based on the bio-sensor information.

[0039] In addition to generating surface maps of sockets as set out above, variations of the apparatus according to the second aspect of the invention may be used to generate a surface map of any three-dimensional surface and could be used not only to analyse irregular surfaces but also changes to regular surfaces in many other and diverse applications, such as pipe inspection in order to identify corrosion or residue, vein inspection for atherosclerosis and aneurysms or the like.

BRIEF DESCRIPTION OF THE DRAWINGS

[0040] In order that the invention may be well understood, there will now be described some embodiments thereof, given by way of example, reference being made to the accompanying drawings, in which:

[0041] FIGS. 1A to 1E are a conceptual representation of the invention where it relates to socket surface acquisition, measurement and rendering.

[0042] FIG. 2 is a view of the first aspect of the laser and camera system.

[0043] FIG. 3A is a section view of a second aspect of the laser and camera system.

[0044] FIG. 3B is a section view of a third aspect of the laser and camera system.

[0045] FIG. 4 is a representation of the laser plane and the camera field of view of the first aspect.

[0046] FIG. 5A is a representation of the laser plane and the camera field of view of the second aspect.

[0047] FIG. 5B is a representation of the laser plane and the camera field of view of the third aspect.

[0048] FIG. 6 is a top view of the laser plane and the camera field of view of the first aspect.

[0049] FIG. 7A is a top view of the laser plane and the camera field of view of the second aspect.

[0050] FIG. 7B is a top view of the laser plane and the camera field of view of the third aspect.

[0051] FIGS. 8A, 8B and 8C are representations of the bio-sensors strip

[0052] FIG. 9 is a conceptual representation of the invention combining the bio-sensor data with the socket surface map, resulting in a superimposed bio-data and virtual socket surface map.

[0053] FIGS. 10A to 10F describe the invention in use, showing a prosthetic technician and a patient with an amputated leg, where the technician is using virtual reality vision system to better observe areas to adjust in the socket.

[0054] FIGS. 11A to 11F describe the invention in use, showing a prosthetic technician and a patient with an amputated leg, where the technician is using an augmented reality device to better observe areas to adjust in the socket.

[0055] FIGS. 12 and 13 show flow diagrams of the method

DETAILED DESCRIPTION OF THE INVENTION

[0056] The invention will now be described on the basis of the drawings. It will be understood that the embodiments and aspects of the invention described herein are only examples and do not limit the protective scope of the claims in any way. The invention is defined by the claims and their equivalents. It will be understood that features of one aspect or embodiment of the invention can be combined with a feature of a different aspect or aspects and/or embodiments of the invention.

[0057] Referring first to FIGS. 1A to 1E, there is shown a summary of the steps involved in mapping and modelling in three dimensions of a socket for an artificial limb. Reference is also made to FIGS. 2 to 4 which shows the apparatus used for the mapping and modelling of the socket in three dimensions. The description below assumes that a laser is used as the radiation source, but it will be appreciated that other beams of light could be used to scan the socket of the artificial limb and this application is not limited to laser scanning.

[0058] FIG. 1A shows a projected laser line 101, as it is projected on the surface of a scanned object. FIG. 1B shows the reference point 102 of the projected laser line 101. In this aspect, the projected laser line 101 is substantially circular in form and the reference point is the centre of the circle, as the centre is computed from data acquired by one or more cameras 411, 511 (see FIGS. 4, 5A and 5B) in a subsequent step. It will be appreciated that the projected laser line 101 may not be circular (or elliptical) in other aspects and, in this case, a suitable reference point needs to be found and used. FIG. 1C shows the projected laser line 101 segmented into discrete data points 103 following identification of the projected laser line 101 by the camera 211. This results in a complete conversion of the projected laser line 101 into a plurality of individual pixels 103, of which A, B and C are representations. By knowing the resolution of the camera 411 and its position relative to the laser beam, by calculating the position of all of the plurality of the line pixels 103, by calibrating the system to infer the real position of each point, the distance of each data point 103 of the line 101 to the reference point 102 may be calculated, and thus position and

spatial coordinates of the data points **103** can be determined. These data points **103** will also represent the actual surface of the scanned object.

[0059] In FIG. 1D, as the camera **211** and laser assembly move together in incremental steps along the z axis, scanning a new area of the socket, variations in the surface dimensions of the socket will result in a corresponding change in the projected laser line **104a-g** being projected thereon. As the projected laser line acquisition, segmentation, pixel conversion and distance-to-reference point process is repeated across the entire depth of the scanned object, this results in a plurality of virtual substantially projected laser lines **104**, which are then joined, as shown in FIG. 1E, to generate a virtual surface map **106** of the scanned object. FIG. 1E also shows a circled x \otimes **105** which represents origin coordinates on the virtual surface map **106** of the scanned object. The circled x as the origin coordinates **105** will be used as a spatial reference point to allow correct alignment with the origin coordinates **105** of a bio-data map at the final stage of the process.

[0060] In FIG. 2, there is shown a schematic illustration of a conical laser assembly **200** according to a first aspect of the invention. There is a moving support assembly **240** which supports a devices support frame **210** and the devices support frame **210** moves with the moving support assembly **240**. The devices support frame **210** supports a camera **211**, a laser device **213** provided with a laser lens **214** and a conical mirror **215**. The moving support assembly **240** is connected to a linear screw **208** by a bushing **209** so as to be moveable towards and away (more frequently vertically) along the longitudinal axis of the scanned socket **216**. The linear screw **208** and moving support assembly **240** are secured to an anchor frame **239** which will be attached to a solid, immovable surface or point such as a wall or an appropriate apparatus housing. The linear screw **208** is attached to a motor **207** mounted on the anchor frame **239**. The motor **207** rotates the linear screw **208**, leading to a movement of the bushing **209** and consequently of all the moving support assembly **240** of all elements (**210**, **213**, **211**, **215**) connected thereto.

[0061] The camera **211** is mounted above a single point laser device **213** which projects a conventional laser beam **236** onto a conical mirror **215**. The laser **213** is arranged to focus the laser beam **236** on the vertex of the conical mirror **215**, and the mirror surface of the conical mirror **215** reflects the laser beam **236** outwards from the plane of the base of the mirror **215** so as to project the laser line **201** extending from the plane of the base of the mirror **215**. The scanned object, a prosthetic socket **216**, is mounted on a fixing base **217** which does not move so that the scanned object remains stationary. A physical origin coordinate **212**, identified by a circled cross \oplus and placed on the surface of the socket **216** provides a spatial reference point which will be useful to orient and align the physical socket **216** with the virtual 3D model of the socket **216** and with the 3D profile of the bio-data.

[0062] In use, the devices support frame **210** moves vertically, starting from a top position where the laser **213** focuses its laser beam **236** on the conical mirror **215** and begins to scan the top of the socket **216**. A line of laser light, the perimeter of which is represented by points line **201** is projected on the internal area of the socket **216**, whereupon the process previously described of laser line acquisition, segmentation, calibration, distance-to-reference point calcu-

lation and line coordinates calculation is performed. These data are stored in a computer (not shown) and the motor **207** turns the linear screw **208** which in turn moves the moving support assembly **240** to the next incremental position, thereby lowering the devices support frame **210** one unit of movement (typically in increments of 5 mm, but this is not limiting of the invention). The entire process is repeated again in a new data acquisition stage until the entire socket **216** internal surface is scanned and mapped. At the conclusion of the process the data corresponding to each slice of socket surface is joined and a full 3D map of the lines is formed, thus rendering a virtual image of the socket **216** as previously shown in FIG. 1F.

[0063] It will be inferred that there is a blind spot on socket **216** mapping caused by the devices support frame **210**, the arms of which will block the field of view of camera **211**. In order to acquire the hidden points on the socket **216** surface, this may be achieved by installing a decoupling mechanism (not shown) between the moving support assembly **240** and the devices support frame **210**, which will allow the support arms of the devices support frame **210** to rotate sufficiently, for the previously hidden portion of laser plane **201** to become visible to the camera **211** while the camera **211** stays in the same position.

[0064] Strips of bio-sensors **219** are arranged on the inside of the socket **216** and will record various biomedical parameters, as explained below. These bio-sensors **219** are described in more detail in connections with FIGS. 8 and 9. Only two bio-sensors **219** are shown on FIG. 2 for simplicity, but in fact the inside surface of the socket **216** will have a much larger number of bio-sensors **219**. It will also be realised that the bio-sensors **219** are shown much larger on this FIG. 2 than in real life, as the bio-sensors **219** should not affect the position of the limb in the socket **216**. The bio-sensors **219** have target or reference markings on their top surface which are visible to the camera. A light source **220**, such as an LED white light, illuminates the inside of the socket **216** and the camera **211** records the position of the bio-sensors **219** using the markings. The camera **211** is moved along the vertical axis and several images are captured. The shape of the markings is known and thus the position of the bio-sensors **219** relative to the vertical axis can be determined. It would also be possible to take images under ambient light.

[0065] FIG. 3A shows a second aspect of the invention which overcomes the blind spot issue discussed above. This second aspect uses the same laser **313** provided with a laser lens **314** which comprises a diffractive optical element **315**. When the laser beam from the laser **313** is directed through diffractive optical element **315**, the optical element **315** diffracts the projected laser beam **337** and produces a projected solid laser line **301**. This is projected outward onto the surface of the scanned socket **316**, the diameter and contour of the projected laser line **301** being dependent on the surface of the scanned socket **316**.

[0066] The laser **313** and the camera **311** are mounted on the device supporting frame **310** that is attached to a moving support assembly **340**. The moving support assembly **340** is connected to a linear screw **308** by a bushing **309** so as to be moveable towards and away (more frequently vertically) along the longitudinal axis of the scanned socket **316**. The linear screw **308** is attached to the anchor frame **339** which will be attached to a solid, immovable surface or point such as a wall or an appropriate floor-standing apparatus housing

341. The linear screw **308** will be attached to a motor **307**, which will rotate the linear screw **308** leading to a movement of the bushing **309** and consequently of the moving support assembly **340** and of all elements (**310**, **313**, **311**, **315**) connected thereto.

[0067] The capturing element in the form of the camera **311** is mounted in a fixed position relative to the laser **313** but unlike the first aspect shown in FIG. 2, the camera **311** is slightly offset from the longitudinal axis of the laser **313**. The camera **311** thus moves with the laser **313** towards and away along the longitudinal axis of the scanned socket **316**. The scanned object, a prosthetic socket **316**, is kept in place by a fixing base **317**, which does not move so that the prosthetic socket **316** remains stationary during scanning. A physical origin coordinate **312**, identified by a circled cross (+) and virtually placed or actually drawn on the surface of the prosthetic socket **316** provides a spatial reference point which will be useful to orient and align the physical prosthetic socket **316** with the virtual 3D model of the prosthetic socket **316** and with the 3D model of the bio-data.

[0068] In use, the laser **313** and the camera **311** move together to scan and map the interior surface of socket **316**. The optical element **315** diffracts the laser light so as to produce a projected laser cone **301** on the surface of the scanned socket **316**, where the laser cone **301** is projected, whereupon the process previously described of line acquisition, segmentation, calibration, distance-to-reference point calculation and line coordinates calculation is performed. These data are stored in a computer (not shown) and the motor **307** moves to the next incremental position, thereby moving the devices support frame **310** one unit of movement (typically but not limiting of the invention, 5 mm), and the entire process is repeated again until the entire socket **316** surface is scanned and mapped. At the conclusion of the process the data corresponding to each slice of socket surface is joined and a full 3D map of the lines is formed, thus rendering a virtual image of the socket **316** as shown in FIG. 1F.

[0069] Unlike the first aspect shown in FIG. 2, the second aspect of FIG. 3A does not have obstacles on the path of the camera **311** or the projected laser line **301**, and there are therefore substantially no hidden areas on the socket **316** surface. It should be noted that data from any hidden areas can be reconstructed mathematically.

[0070] A third aspect of the invention is shown in FIG. 3B which shows an arrangement with two (or more) cameras **311** positioned to the right and left of the laser **313**. The other elements depicted in FIG. 3B are otherwise identical with those of FIG. 3A. The arrangement shown in FIG. 3B is able to scan more accurately the surface because more information from the two cameras **311** is gained and a stereographic picture can be formed.

[0071] In FIG. 4, there is shown a schematic representation of the first aspect of the invention, comprising a camera **411**, a field of view **418** and a laser plane **401**, created by the reflection of the laser beam from the laser **413** on the conic mirror **415**. The camera field of view **418** has a centre **C1**, a length **C3** and a width **C2**, so that the image which will be captured will have $C3 \times C2$ pixels and this number of captured pixels will vary depending on camera resolution of the camera **411**. The laser plane **401** will have a variable shape depending on the surface and shape of the scanned object, e.g. the prosthesis socket **216** shown in FIG. 2. When scanning the socket **216**, the laser plane **401** will project a

circle of laser light with a centre **L1** of a shape which will most frequently be roughly elliptical. **L3** and **L4** are examples of the variable diameters of that elliptical shape. In this first aspect, the centre points **C1** and **L1** are in the same x, y, and z position and will be considered to the reference point in this first aspect. By keeping a fixed distance **L2** between the camera **411** and the laser plane **401**, it is possible to determine a calibration rule that relates the dimension in pixels in the virtual image to the dimension in millimetres of the real scanned object (e.g. socket **216**) and with this rule calculate the position of each point of the scanned object surface. By joining all these points acquired at each acquisition stage, a full model of the scanned object may be obtained.

[0072] In FIGS. 5A and 5B, there are shown a schematic representation of the second aspect and the third aspect of the invention. These FIGS. 5A and 5B show a laser **513**, a single camera **511** in FIG. 5A and two cameras **55** in FIG. 5B, a diffractive optical element **515**, a single camera field of view **518** in FIG. 5A and two camera fields of view **518** in FIG. 5B and a projected laser beam **501**. The projected laser beam **501** produces a pattern of know dimensions and shape. It could be for example, a cone or a grid pattern, but this is not limiting of the invention. It will be noted that the laser **513** and the camera(s) **511** are fixed in relation to each other. The diffractive element **515** creates a laser plane **501** with an angular opening **L5**. The laser plane **501** has a variable shape according to the scanned object shape and surface and the diffractive element **515**. The camera field of view **518** depicted in FIG. 5A has a reference axis **C1**, a length **C3** and a width **C2**. The projected laser beam produces a series of laser scans **501** along the reference axis will have a variable shape depending on the surface and shape of the scanned object. When scanning the socket **316** of FIG. 3, each successive laser scan **501** be imaged as a two-dimensional image in the camera(s) **511** will again have a reference point **L1** on the reference axis and **L3** and **L4** are examples of the points of the scan.

[0073] However, in this second aspect shown in FIG. 5A, camera field of view reference point **C1** and laser reference point **L1** are in different positions and the distance **D1** between the camera field of view reference point **C1** and the laser plane reference point **L1** is a function of the distance between the reference axis of the laser **513** and the reference axis of the camera **511**. The field of view reference point **C1** will always be on the same longitudinally oriented reference axis of the camera in successive ones of the (two-dimensional) images taken at each of the image acquisition stage. However, the laser plane reference point **L1** in the camera field of view will vary as the surface of the scanned object **316** approaches the camera **511** or moves away from the camera **511**. For a given point of the projection of the laser beam on the scanned object **316**, it is possible to define a line of view from the point of projection to the camera(s) **511**. The world coordinates of this given point will be the intersection of this line of view from the camera(s) **511** to the projected laser pattern. These variable distances and the changing of the laser reference point **L1** require appropriate calculation, calibration and dynamic calibration methods, to relate the virtual dimensions of each of the series of images acquired by the camera **511** with the real dimensions in millimetres of the scanned object surface upon which the projected laser beam **501** is projected and thus to determine with precision the correct coordinates of each point of the

projected laser beam **501** and therefore the correct surface measurement of the scanned object **316**. This variable value of distance **D1** only occurs in the images (virtual **D1**). In reality, the distance between the reference axis of the laser **513** and the reference axis of the camera **511** (real **D1**) is always substantially the same, thus allowing to compute the dynamic calibration method.

[0074] Similar issues occur with the third aspect of the invention shown in FIG. 3B, which includes two cameras **311**. The third aspect is different from the second aspect in the sense that the two (or indeed more) cameras **311** require a variation of the method for achieving the 3D reconstruction. As described with respect to the first and second aspects, the cameras **311** and laser **313** are moved along the vertical axis and the projected laser beam **337** is captured by both of the cameras **311**. This capture can be simultaneously performed or statically.

[0075] The relative orientation/position and origin of the field of views of the cameras **311** is known and thus by identifying a given physical reference (i.e. a point **301** of the projected laser beam) in the captured image by both cameras **311**, it is possible to infer the relative position of the point **301** of the projected laser beam **337** to the reference axis. The reference axis has an origin between the cameras **311**. This same physical reference of the point **301** captured by both of the cameras **311** is represent by different pairs of pixels in the two-dimensional images taken by the cameras **311** and it is this difference combined with the position and orientation between cameras **311** that enables the calculation of the three-dimensional position of the points **310** on the projected laser beam **337**.

[0076] To find the relative position between both of the cameras **311** (after being placed in the camera mount), several images of a given reference figure should be captured simultaneously by both cameras **311**, at different distances and orientation to the cameras **311**. For example, the given reference figure could be a chessboard, but this is not limiting of the invention. By identifying key-points in this reference figure in both of the captured images (either by manually picking or automatic processing) and previously knowing their real/physical distances between key points in the reference figure, it is possible to mathematically determine the relative position between the field of view of both of the cameras **311**.

[0077] Both the sockets **316** in FIGS. 3A and 3B have bio-sensors **319** as explained in connection with FIG. 2. A light source **320** illuminates the bio-sensors **319** and the camera(s) **311** record the position of the bio-sensors **319**. In the case of FIG. 3B, there are two light sources **320**.

[0078] FIG. 6 illustrates a top view of the first aspect, comprising the camera **611** and the laser **613**, and their respective longitudinal axes are aligned along the same axis. The laser plane **601** is centred and inside the camera field of view **618**.

[0079] FIG. 7A shows a top view of the camera **711** and the laser **713** in the second aspect, showing the two devices, the camera **711** and the laser **713** to be placed no longer along the same axis, but offset from each other, resulting in the centre of laser plane **701** to be different from the reference axis, i.e. centre of camera field of view **718**. Similarly, FIG. 5B shows the same top view of the third aspect of the invention with two cameras **711**.

[0080] It will be appreciated that the use of the two cameras **311**, **511**, **711** in the third aspect of the invention

means that both cameras **311**, **511**, **711** need to be calibrated in order to know the precise relative position and pose between the two cameras **311**, **511**, **711** and the lens distortion in each of the two cameras. These parameters are always different due to manufacturing variability.

[0081] To calibrate the cameras **311**, **511**, **711** and to compensate for difference in the lens parameters of the cameras **311**, **511** and **711**, a method based on Zhang. "A Flexible New Technique for Camera Calibration" published in IEEE Transactions on Pattern Analysis and Machine Intelligence, 22(11):1330-1334, 2000, is used. This method requires a custom-designed camera mount which holds both cameras **311**, **511**, **711** and the laser **313**, **513**, **713** i.e. the same laser that will be used in the laser scanner system. In the calibration, a chessboard design placed in a flat surface is used as a reference figure. The dimensions of the squares of the chessboard is known. A number of pictures are taken simultaneously from both of the cameras **311**, **511**, **711** in which the chessboard is placed at different distances to the cameras **311**, **511**, **711** and at different orientations.

[0082] The corners of the chessboard of every pair of images taken from the cameras **311**, **511**, **711** are detected. The number of squares of the chessboard are known and thus it is simple to match the corners detected by both of the stereo images taken from the two cameras **311**, **511**, **711**. The chessboard plane is considered to be at $z=0$, only leaving the problem to be solved only in this plane (with origin in one of the corners of the chessboard).

[0083] Each of the images is automatically processed in order to find the chessboard patterns, acquiring one conversion from the image corner pixels to the real 3D positions of the chessboard. This enables the computation of the intrinsic lens parameters for each of the cameras **311**, **511**, **711** (i.e. distortion coefficients), by trying to minimize the 2D->3D re-projection error in all images. After carrying out this calculation, it is possible to use these 2D-3D correspondences to calculate the transformation matrix between the images from the two cameras **311**, **511**, **711**.

[0084] This calibration enables the computation of the matrix which projects the images of both cameras **311**, **511**, **711** onto a common image plane, i.e., to rectify the images. This process makes it easier to find correspondences between the stereo images because the process aligns the image in such a way that theoretically it is only necessary to search along a single line (if the calibration is accurate, correspondent points are in the same row of the rectified images). After constructing the undistorted and coplanar image planes, the 3D reconstruction can be achieved by triangulation.

[0085] FIG. 8 now illustrate the bio-sensors. FIG. 8A shows a top view of bio-sensor strip **821** comprising bio-sensors **819** and power and data leads **820**, which in turn connect to a power and data connector **823**, itself connected to a transmitting device **822** that can be connected, preferably wirelessly, to a computer or handheld mobile smart device (not shown).

[0086] FIG. 8B shows a section view of the bio-sensor strip of FIG. 8A, comprising two strips of plastic film **824** and **825**, which sandwich the bio-sensors **819**. In one aspect, the bio-sensor **819** are pressure sensors, but as noted elsewhere, other types of sensors can be used. The bio-sensor comprises a pressure-sensitive resistor which resistance changes depending on the load or pressure applied to the

bio-sensor **819**. Measurement of the change of resistance is carried out using a bridge circuit.

[0087] The power leads and data leads **820** made, for example, of silver ink are not illustrated in this FIG. **8B**. Side **A1** of plastic film **824** will be in contact with the stump skin, i.e. the skin on the residual limb, or the liner covering the residual limb, and will preferably have a bio-compatible finish. A non-limiting example of the bio-compatible finish is polyurethane. Side **A2** of the plastic film **824** faces the bio-sensors **819** and holds the bio-sensors **819** in place. Preferably, the side **A2** has an adhesive finish from, for example, a medical grade acrylic adhesive, so that the bio-sensors **819** do not move.

[0088] Side **B1** of polymer film **825** on FIG. **8B** faces the bio-sensors **819** and holds the bio-sensors **819** in place. The side **B1** may have an adhesive finish, e.g. from a medical grade acrylic adhesive, so that bio-sensors **819** do not move. The side **B2** of the plastic film **825** is, for example, silicone and will be in contact with the prosthetic socket surface of the prosthetic surface **216, 316** (not shown in FIG. **8B**). The side **B2** will preferably have an adhesive finish, so that the bio-sensor strip **819** is firmly held in place on the socket surface.

[0089] The side **A1** of the plastic film **824** will have one or more markings **830** on the surface. These markings are illuminated by the light source **220, 320** to locate the bio-sensors on the inside of the socket **216, 316** as explained previously. In one non-limiting aspect, the markings are multi-coloured roundels (concentric circles). The different colours are used to indicate differing positions or the different types of bio-sensors within the socket **216, 316**. Currently, at least two markings per strip are required to uniquely identify the position of the bio-sensor strip **819**, but a single marking could be acceptable.

[0090] FIG. **8C** shows a section view of a simpler embodiment of the bio-sensor strip **819**, comprising a single plastic film **825**, to which the bio-sensors **819** with an adhesive finish **826** are applied to the **B1** side of the plastic film **825**. This side **B1** faces the stump skin and has a bio-compatible finish, while side **B2** of plastic film **825** will be in contact with the prosthetic socket surface of the prosthetic socket **216, 316** and will preferably have an adhesive finish, so that the bio-sensor strip **819** is firmly held in place on the socket surface. It will be appreciated that the sides **B1** and **B2** could be reversed so that **B2** is in contact with the stump skin.

[0091] Before use, the bio-sensor strips **819** are covered on the adhesive side with a peelable cover if dispensed in pre-cut strips, or not covered if they are dispensed in rolls. In use, the peelable covers are removed, the bio-sensor strips **820** are cut to the right size, if needed, and the bio-sensor strips **820** are applied to the internal surface of the prosthetic socket **216, 316**, in the orientation best determined by the prosthetic fitting technician's experience.

[0092] The biosensor strips **819** can measure different types of biodata, which include but are not limit to pressure between the stump skin and the prosthetic socket surface, or temperature. In one non-limiting example, the biosensor strips are formed of a force sensing resistor comprising at least one polymer layer whose resistance varies on application of a pressure. The change in the resistance can be measured, for example, by a bridge circuit. In one aspect of the bio-sensor a plurality of polymer layers is used with different characteristics to allow a wide range of different pressures to be measured.

[0093] FIG. **9** shows the elements of the complete system of the present invention. The bio-sensor strip **921** comprising the bio-sensors **919** acquires the bio-data which is transmitted to a computer, a hand-held device or similar data processing device **927**. The bio-sensor strips **921** are applied to an internal surface of the prosthetic socket **916**, resulting in a sensorized socket **928**, which will receive a residual stump **932** of the residual limb. The bio-sensor strips **921** are positioned in relation to the real origin coordinate **912**, which is known or which can be automatically determined by the light source **220, 320** scanning system as shown and described with respect to FIGS. **2** and **3**. The data from each of the bio-sensors **919** can be overlaid on the socket surface map **906** generated by the light source scanning system by using a computing device **927**, resulting in a 3D bio-data profile **930**. The 3D bio-data profile **930** can be oriented by relating the virtual origin coordinate **905** with the real origin coordinate **912**, allowing the accurate representation of the bio-data profile **929** with the socket surface map **906**.

[0094] Furthermore, the spacing between the bio-sensor strips **921** can be adjusted to vary the resolution of the data obtained—the bio-sensor strips **921** can be arranged closer together or even on top of each other with an offset in areas where greater data resolution is required. When evaluating pressure, a correct fit between the stump **932** and the socket **916** will produce uniform pressure distribution across certain areas of the surface of the socket **916**, depending on the socket type, while a poor fit will produce areas of altered pressure which will be evidenced by more concentrated curves in the bio-data profile **929**, in zones where this should not occur.

[0095] It will be appreciated that absolute values from the bio-sensors are not required. The values can be normalised or otherwise mathematically manipulated with respect to the maximum value recorded.

[0096] Artificial colour may be added to the bio-data profile **929** to create a heat map and thus illustrate the areas of pressure. Shifts in the colour may be used to differentiate between areas of equally uncomfortable areas of increased or reduced pressure, such as red for higher pressure, and blue for lower pressure. The prosthesis technician can therefore identify high pressure areas of the socket **916** which need fine tuning and shaping back as well as areas of lower pressure which indicate regions of the socket **916** which need building up. Other types of bio-data of interest may be represented using the same method.

[0097] The arrangement of the bio-sensors **919** on the bio-sensor strips **921** enables the system to be wearable, non-invasive, autonomous (with long battery time), modular, flexible (with different placement of sensors), scalable (more sensors as needed), and versatile (different type of modules/sensors).

[0098] The images of the bio-sensor strips **921** are drawn on the surface of the stump **932** to indicate their location in relation to the stump **932**. The real origin coordinates **912** are actually or virtually drawn on the scanned socket **916** and the scanning and data acquisition apparatus produces the 3D image of the scanned socket **906**.

[0099] An example can serve to illustrate this in more detail. Suppose the prosthesis is an artificial leg or an artificial arm. In use, the patient with the artificial leg is made to walk (in the case of a leg) or move (in case of an artificial arm) for a certain amount of time until sufficient bio-sensor data has been obtained from the bio-sensors **919**

to produce the virtual 3D bio-data profile **930** comprising bio-data profile curves **929** of the pressure, temperature or any other bio-data of interest. The position of these bio-data profile curves **929** is known by reference to virtual origin coordinates **905** of the 3D bio-data profile **930**.

[**0100**] It is also possible to combine the bio-sensor data with data from one of more inertial motion units which is carried by the patient and attached to the limb. The inertial motion unit will have three, six or nine axes and provide information about the changes in the data as the patient moves. This data can be used to characterise potential gait anomalies.

[**0101**] FIGS. **10A-C** shows the fitting of a prosthetic leg using the components of the present invention, using a virtual reality or augmented reality vision system.

[**0102**] FIG. **10A** shows a prosthesis fitting technician using a virtual reality or augmented reality vision system **1031** and the residual member **1032** of a user. It will be noted that some residual members **1032** are covered with liners or socks, part of which is shown as **1033** on the figure.

[**0103**] FIG. **10B** shows what the prosthesis fitting technician sees through the virtual reality or augmented reality vision system **1031**, which superimposes the 3D surface map **1006** of the socket **916**, which has been obtained by the scanning, imaging and surface determination system of the present invention, with the virtual origin coordinate point **1005** of the socket **916**, themselves precisely aligned with the user's residual limb **1032**, in the same limb location where the socket **916** was worn during the testing and data acquisition phase (walking, moving). This allows the prosthesis fitting technician to correctly identify the problematic areas of the socket **916**.

[**0104**] Furthermore, a light grid may be projected onto the patient's stump or over the surface of the actual socket **916** which is calibrated to the 3D socket model so as to help the prosthetic fitting technician to correlate the 3D image with the actual socket surface of the socket **916** and hence help identify the areas that need adjustment on the actual socket surface.

[**0105**] FIG. **10C** shows the same image as FIG. **10B**, but now the virtual reality or augmented reality vision system **1031** of the present disclosure adds the layer of the bio-data profile **1030** and the bio-data profile maps **1029** to FIG. **10B**. At the virtual origin coordinate point **1005** two virtual origin coordinate points are precisely superimposed: the origin point of the 3D socket surface map **1006** and the origin point of the bio-data profile **1030**, both precisely aligned with the same limb location where the socket **916** was worn during testing. The alignment of all of these origin coordinate points is needed so that bio-data obtained actually matches the appropriate area of the physical socket **916** and the corresponding area of the residual limb **1032** location.

[**0106**] The purpose of the layering of the various data maps is to evidence the areas where pressure, temperature or other data are more intense, and which may indicate areas of pain or discomfort for the person wearing the prosthesis, or less intense which may indicate areas which lack support.

[**0107**] In FIG. **10D**, the prosthetic fitting technician is now shown holding the socket **1016** and a shaping tool **1038**. The prosthetic fitting technician will now begin to shape the socket **1016**, using the virtual reality or augmented reality vision system **1031**, which is able to correctly display all of the data obtained by the virtual reality vision system **1031**

and to referencing the data to the physical socket **1016** by identifying the real origin coordinate point **1012** on the socket **1016**.

[**0108**] FIG. **10E** shows the visualization of the 3D socket surface map **1006** over the actual prosthetic socket **1016**, using the virtual reality or augmented reality vision system **1031**. This displays the information of the 3D socket surface map **1006** over the corresponding zones of the prosthetic socket **1016**, which can be achieved by using the virtual origin coordinate **1005**.

[**0109**] FIG. **10F** shows the visualization of the 3D bio-data profile **1030** over the physical prosthetic socket **1016**, using the virtual reality vision system **1031**. The display of the information of the 3D bio-data profile **1030** is overlaid onto the corresponding zones of the prosthetic socket **1016**, which can be achieved using the virtual origin coordinate **1005** of three data sets (bio-data profile curves, socket surface model and physical stump) and overlapping the bio-data profile curves **1029** over the surface map **1006**, allowing the prosthetics fitting technician to correctly and quickly identify the areas that require adjustment.

[**0110**] FIG. **11** shows a similar process to that described in FIGS. **10A-F**, but now the prosthetics fitting technician is using an augmented reality device, such as a portable smart tablet equipped with augmented reality software and appropriate rendering and layering software. This avoids using the cumbersome virtual reality vision system and allows the technician to observe all of the necessary information on the same plane.

[**0111**] In FIG. **11A** shows the prosthetic fitting technician using a handheld device **1134**, such as a tablet or any other mobile device, mounted on a flexible arm support **1135** fixed to a solid surface such as a wall or table (not shown) to examine the patient's residual limb **1132**.

[**0112**] FIG. **11B** shows the image as seen by the technician of the socket surface map **1106** superimposed over the amputee residual limb **1132**, using the handheld device **1134**. This handheld device **1134** displays the information of the socket surface map **1106** over the corresponding zones of the residual limb **1132**. Both images are aligned by means of both the virtual socket origin coordinate **1105** and the real stump origin coordinate **1112**.

[**0113**] FIG. **11C** now adds to the handheld device's display **1134** the visualization of the 3D bio-data profile **1130** over the amputee residual limb **1132**, using the handheld device **1134**. This displays the information of the 3D bio-data profile **1130** over the corresponding zones of the residual limb **1132**, which can be achieved using both the virtual socket origin coordinate **1105** and the real stump origin coordinate **1112**, and overlapping the bio-data profile curves **1129** over the socket surface map **1106**, allowing the prosthetics fitting technician to correctly and easily identify the problematic areas and to shape the problematic areas.

[**0114**] In FIG. **11D**, the prosthetics fitting technician goes to work with a shaping tool **1138** on the socket **1116** which is observed by means of the handheld device **1134** mounted on a flexible arm support **1135** and which is oriented by means of the real origin coordinate **1112**.

[**0115**] FIG. **11E** shows the image as seen by the technician of the surface map **1106** over the prosthetic socket **1116**, using the handheld device **1134**. This handheld device **1134** displays the information of the surface map **1106** over the corresponding zones of the physical prosthetic socket **1116**,

which can be achieved using both the virtual origin coordinate **1105** and the real origin coordinate **1112**.

[0116] FIG. 11F now adds to the handheld device's display **1134** visualization of the 3D bio-data profile **1130** over the prosthetic socket **1116**, using a handheld device **1134**. This displays the information of the 3D bio-data profile **1130** over the corresponding zones of the prosthetic socket **1116**, which can be achieved using both the virtual origin coordinate **1105** and the real origin coordinate **1112** and overlapping the data profile curves **1129** over the surface map **1106**, allowing the prosthetics fitting technician to correctly and quickly identify the problematic areas.

[0117] The alignment of the socket surface map **1106** and/or the 3D bio-data profile **1130** over the object of interest can be achieved by using the same origin coordinate in the real object (real origin coordinate **1112**), in the socket surface map **1106** (virtual origin coordinate **1105**) and in the 3D bio-data profile **1130** (virtual origin coordinate **1105**), or by resorting to a best match algorithm, that computes the best geometrical match between two 3-dimensional objects.

[0118] The method will now be described with respect to the flow diagrams shown in FIGS. 12 and 13. The method starts at step **1200** and the object **216, 316**, for example the prosthesis **932**, is scanned in step **1205**. A plurality of the biosensors **919** are attached to either the surface of the object **216, 316** or the body part, for example the stump **919**, in step **1210**. The object **216, 316** is subsequently engaged with the body part **919** in step **1215** and data is collected in step **1220** from the bio sensors **919**. The collected data is processed in step **1222** and superimposed in step **1225** over the surface map **1006** of the object **216, 316** to identified areas of the object **216, 316** that need to be adjusted. The superimposed data on the surface map **1006** is displayed as a 3D model to the user, for example the prosthetics fitting technician, in step **1227** before adjustments are made in step **1230**.

[0119] The method for creating the surface map is shown in FIG. 13 which starts with scanning the object **216, 316** in step **1300** using a laser **213, 313** projecting a laser line **201, 301** on the surface of the object **216, 316**. An image of the object **216, 316** with the laser line **201, 301** is taken in step **1310** and the image data analyses in step **1315**. If all of the object **216, 316** has been scanned in step **1320**, then the method is completed in step **1330** and the surface map of the object **216, 316** is created. Alternatively, the distance between the laser and the object **216, 316** is moved to scan a different part of the object **216, 316** in step **1325**.

[0120] The present invention comprising the use of the bio-sensors, the mapping of the internal surface of the prosthetic socket, the generation of bio-data related to socket/stump fit and the identification of socket areas which require adjustment represents several economic and comfort benefits. The method is non-invasive, unobtrusive and does not require a clinician's attendance. It saves considerable time in the fitting process, thereby reducing cost and increasing the patient's quality of life.

REFERENCE NUMERALS

[0121]	101 Laser Line	[0128]	201 Projected radiation line
[0122]	102 Centre	[0129]	207 Motor
[0123]	103 Data Points	[0130]	208 Linear screw
[0124]	104 Laser line	[0131]	209 Bushing
[0125]	105 Origin coordinates	[0132]	210 Support frame
[0126]	106 Surface map	[0133]	211 Camera
[0127]	200 Conical laser assembly	[0134]	212 Physical origin coordinate
		[0135]	213 Laser
		[0136]	214 Laser lens
		[0137]	215 Conical mirror
		[0138]	216 Socket
		[0139]	217 Fixing base
		[0140]	219 Bio-Sensors
		[0141]	220 Radiation source
		[0142]	236 Radiation beam
		[0143]	239 Anchor frame
		[0144]	240 Support assembly
		[0145]	241 Wall or housing
		[0146]	300 Conical laser assembly
		[0147]	301 Projected radiation pattern
		[0148]	307 Motor
		[0149]	308 Linear screw
		[0150]	309 Bushing
		[0151]	310 Device supporting frame
		[0152]	311 Camera
		[0153]	312 Original coordinate
		[0154]	313 Laser
		[0155]	314 Laser lens
		[0156]	315 Optical element
		[0157]	316 Scanned socket
		[0158]	317 Fixing base
		[0159]	319 Bio-sensors
		[0160]	320 Radiation source
		[0161]	339 Anchor frame
		[0162]	340 Support Assembly
		[0163]	341 Wall or housing
		[0164]	401 Laser Plane
		[0165]	411 Camera
		[0166]	413 Laser
		[0167]	415 Conic mirror
		[0168]	418 Field of view
		[0169]	501 Laser plane
		[0170]	511 Camera
		[0171]	513 Laser
		[0172]	515 Optical Element
		[0173]	518 Field of view
		[0174]	601 Laser plane
		[0175]	611 Camera
		[0176]	613 Laser
		[0177]	618 Field of view
		[0178]	701 Laser plane
		[0179]	711 Camera
		[0180]	713 Laser
		[0181]	719 Field of view
		[0182]	819 Bio-sensors
		[0183]	820 Data Leads
		[0184]	821 Bio-sensor strip
		[0185]	822 Transmitting device
		[0186]	823 Power and data connector
		[0187]	824 Plastic film
		[0188]	825 Plastic film
		[0189]	826 Adhesive finish
		[0190]	830 Markings
		[0191]	905 Virtual original coordinates

[0192] 906 Socket surface map
 [0193] 912 Real origin coordinate
 [0194] 916 Prosthetic socket
 [0195] 919 Bio-sensors
 [0196] 921 Bio-sensor strip
 [0197] 927 Data processing device
 [0198] 928 Sensorised socket
 [0199] 929 Curves
 [0200] 930 Bio data profile
 [0201] 932 Stump
 [0202] 1005 Virtual origin coordinate point
 [0203] 1006 3D surface map
 [0204] 1016 Socket
 [0205] 1029 Bio-data profile maps
 [0206] 1030 Bio-data profile
 [0207] 1031 Virtual reality vision system
 [0208] 1032 Residual member
 [0209] 1033 Liner or sock
 [0210] 1038 Shaping tools
 [0211] 1105 Virtual origin coordinate point
 [0212] 1106 Socket surface map
 [0213] 1112 Real sump origin coordinate
 [0214] 1129 Bio-data profile curves
 [0215] 1130 Bio-data profile
 [0216] 1132 Residual limb
 [0217] 1134 Handheld device
 [0218] 1135 Support
 [0219] 1138 Shaping tool

1. A method of identifying the differences in shape and the physical contact characteristics between an object and a body part which is engageable with the object comprising:
 scanning the object with radiation in order to produce a surface map of the object;

attaching a plurality of bio-sensors to at least one of a surface of the object or to a surface of the body part at locations which are known relative to a reference point, engaging the body part with the object;

collecting bio-sensor data from the bio-sensors to record information on the engagement between the body part and the object over the surface of the object; and

superimposing the data from the bio-sensors over the surface map of the object in order to identify areas of the object which need to be adjusted in order to improve the fit of the body part with the object.

2. The method of claim 1, wherein the object is one of a prosthetic socket, an orthotic article, an article of furniture, or a wheelchair, and the body part is one of a stump of an amputated limb, stump of an amputated foot, a complete limb, a skin of a patient, a bottom sitting on a wheelchair, a back lying on a bed, or a liner covering at least part of the body part.

3. (canceled)

4. The method according to claim 1, wherein the scanning comprises:

projecting radiation pattern onto the surface of the object with a radiation source at a first distance from the surface of the object;

taking as image data an image of the radiation projected onto the surface using at least one capturing element which is in a fixed and known position relative to the radiation source;

analyzing the image data from the capturing element to identify a position in three dimensions of each point illuminated by the projected radiation;

varying the distance of the radiation source from the surface in order to change the parts of the surface illuminated by the projected radiation;

using the data from the capturing element in order to identify the position of each new point illuminated by the projected radiation; and

repeating until all points on the surface have been scanned.

5. The method according to claim 2, wherein locations of the plurality of biosensors is determined by illuminating the plurality of biosensors and capturing image data.

6. The method according to claim 2, wherein the scanning is carried out by a radiation pattern as a projected laser pattern.

7. The method according to claim 2, wherein the collecting of data comprises one of data relating to pressure or temperature at the locations.

8. The method according to claim 2, further comprising displaying a 3D model of the mapped surface to a user with the bio-sensor data superimposed thereon.

9. The method according to claim 1, further comprising projecting onto the surface of the object a pattern which is calibrated to the surface map generated by a computer so as to enable a user easily to correlate the actual surface with the virtual surface and hence easily identify on the real surface areas of the object which need adjusting based on the bio-sensor information.

10. The method according to claim 8, wherein the object is a prosthetic socket and the adjusting comprises forming an interior surface of the prosthetic socket.

11. The method according to claim 1, further comprising using data from at least one motion unit to identify areas of the object which need to be adjusted in order to improve the fit of the body part with the object during movement.

12. An apparatus for identifying the differences in shape and physical contact characteristics between an object and a body part which is engageable with the object, the apparatus comprising:

a radiation source for scanning the surface of the object in order to produce a surface map thereof;

an adjuster for varying at least one of a distance or orientation of the radiation source from the surface of the object;

a plurality of bio-sensors attachable to at least one of the surface of the object, to the surface of the body parts or to liners covering body parts at locations which are known relative to a reference point,

data collectors connected to the plurality of bio-sensors for collecting bio-sensor data from the plurality of bio-sensors;

data processing device adapted for superimposing the bio-sensor data onto the surface map to produce a bio-data profile map of the object; and

a display for displaying the bio-data profile map to a technician.

13. The apparatus of claim 12, wherein the plurality of bio-sensors are arranged as a bio-sensor strip comprising plastic films, powder leads and data leads, a power and data connector, wherein the plurality of bio-sensors are disposed on the bio-sensor strip (821, 921) and at least one power lead and data lead is connected to one or more of the plurality of bio-sensors and the at least one power lead and data lead are placed on the bio-sensor strip and are in contact with an

interlace component itself connected with a power supply and the data processing device.

14. The apparatus according to claim 12, wherein the radiation source is a conical laser assembly which comprises a single point laser and an optical element which converts the single laser beam into a two-dimensional

15. (canceled)

16. (canceled)

17. An apparatus according to claim 12, further comprising a capturing element associated with, and in a known position relative to pattern on the surface and measuring the distance between a plurality of points illuminated by the radiation source and the capturing element, and a data processing device for processing the data from the capturing element and converting the data into a map of the surface.

18. An apparatus according to claim 17, wherein the capturing element is arranged in a fixed position relative to the radiation source, the distance from the laser being known, and moves with the radiation source towards and away from the surface.

19. (canceled)

20. The apparatus according to claim 12, further comprising a plurality of light sources for illuminating the surface of the object to identify locations of the plurality of biosensors.

21. (canceled)

22. (canceled)

* * * * *

专利名称(译)	装修系统		
公开(公告)号	US20200197195A1	公开(公告)日	2020-06-25
申请号	US16/075082	申请日	2018-01-15
[标]发明人	SAENZ ESPINOZA MARIO ABREU CARPINTEIRO FREDERICO ALBERTO		
发明人	SAENZ ESPINOZA, MARIO ABREU CARPINTEIRO, FREDERICO ALBERTO		
IPC分类号	A61F2/76 A61F2/80 A61B5/00		
CPC分类号	A61B2562/0295 A61B2562/0271 A61F2002/7635 A61F2/76 A61B2562/0219 A61F2002/7665 A61B2562/0247 A61B5/0073 A61B5/0082 A61F2/80 A61B5/68335 A61B5/0064 A61B2562/029 A61B90/06 A61B2090/065 A61F2/5046 A61F2/50		
优先权	100021 2017-01-13 LU		
外部链接	Espacenet USPTO		

摘要(译)

一种使用诸如激光之类的辐射源扫描和测量物体表面的方法和设备。当与来自生物传感器的生物数据结合以创建轮廓时，本发明对于测量假体窝的内表面并改善窝与残肢之间的贴合性特别有用。

