



US 20170153669A1

(19) **United States**

(12) **Patent Application Publication**
Wang et al.

(10) **Pub. No.: US 2017/0153669 A1**
(43) **Pub. Date: Jun. 1, 2017**

(54) **MULTI-FACED DISPLAY DEVICE**

A61B 5/00 (2006.01)
A61B 5/01 (2006.01)

(71) Applicants: **BOE TECHNOLOGY GROUP CO., LTD.**, Beijing (CN); **BEIJING BOE OPTOELECTRONICS TECHNOLOGY CO., LTD.**, Beijing (CN)

(52) **U.S. Cl.**
CPC *G06F 1/1647* (2013.01); *G06F 1/1652* (2013.01); *A61B 5/015* (2013.01); *A61B 5/14532* (2013.01); *A61B 5/7445* (2013.01); *A61B 5/0075* (2013.01); *A61B 2560/0462* (2013.01); *A61B 2562/06* (2013.01)

(72) Inventors: **Jiaheng Wang**, Beijing (CN); **Feng Bai**, Beijing (CN); **Jiuxia Yang**, Beijing (CN)

(57) **ABSTRACT**

(73) Assignees: **BEIJING BOE OPTOELECTRONICS TECHNOLOGY CO., LTD.**, Beijing (CN); **BOE TECHNOLOGY GROUP CO., LTD.**, Beijing (CN)

The present disclosure discloses a multi-faced display device, comprising a first display panel and a second display panel, wherein each of the first display panel and the second display panel is provided with a lateral side curving toward a back side of a display region to form an L-shaped structure, a lateral side of the first display panel opposite to the curved lateral side is encapsulated with the curved lateral side of the second display panel, and the curved lateral side of the first display panel is encapsulated with a lateral side of the second display panel opposite to the curved lateral side to form a closed structure, and a display surface of the multi-faced display device is an outside surface of the closed structure. A function of displaying images may be achieved on surfaces of the closed structure of the multi-faced display device in at least four directions; furthermore, the display device employs two L-shaped display panels to achieve a curved display surface resulting from connection of two groups of display surfaces in two directions via arcuate surfaces, thereby enhancing continuity of images displayed in respective directions of the multi-faced display device, as compared with a multi-faced display device formed by a plurality of planar display panels which has a plurality of edges upon display on multiple surfaces.

(21) Appl. No.: **14/785,564**

(22) PCT Filed: **May 28, 2015**

(86) PCT No.: **PCT/CN2015/080098**

§ 371 (c)(1),

(2) Date: **Oct. 19, 2015**

(30) **Foreign Application Priority Data**

Dec. 12, 2014 (CN) 201410773839.9

Publication Classification

(51) **Int. Cl.**
G06F 1/16 (2006.01)
A61B 5/145 (2006.01)

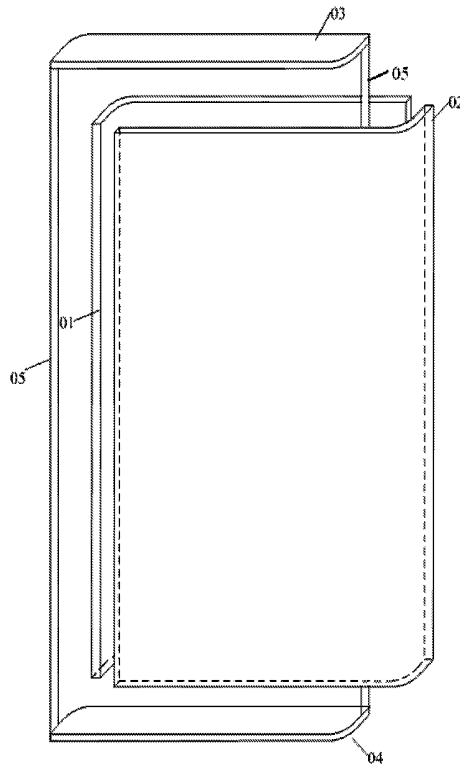

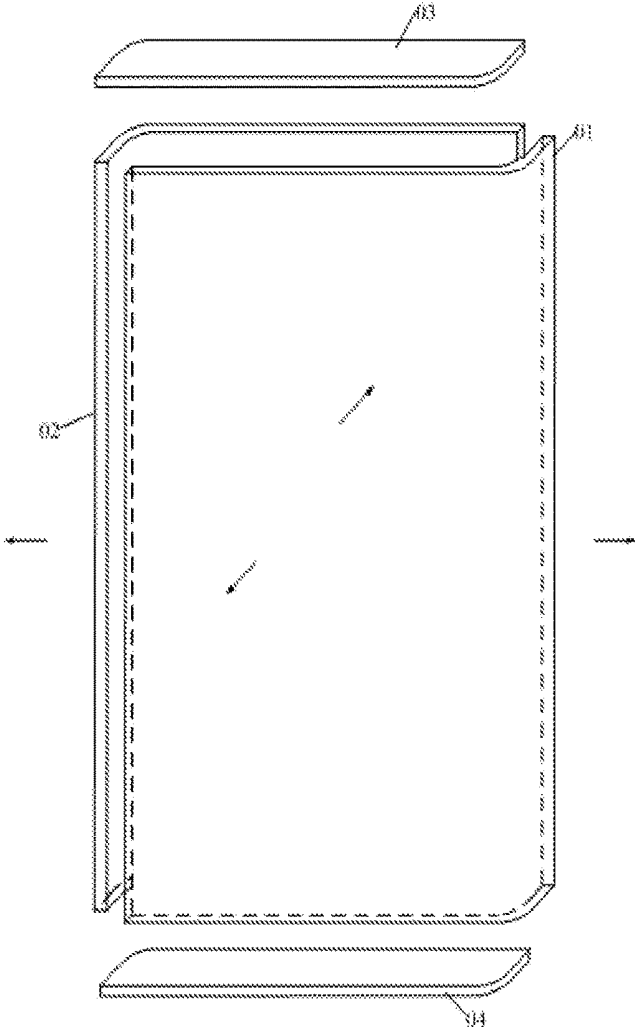

FIG. 1

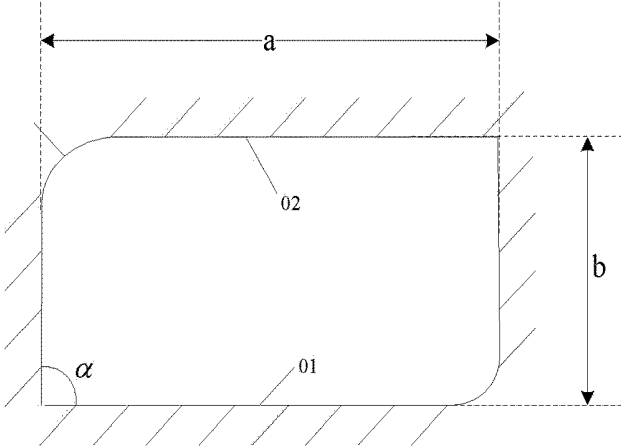

FIG. 2

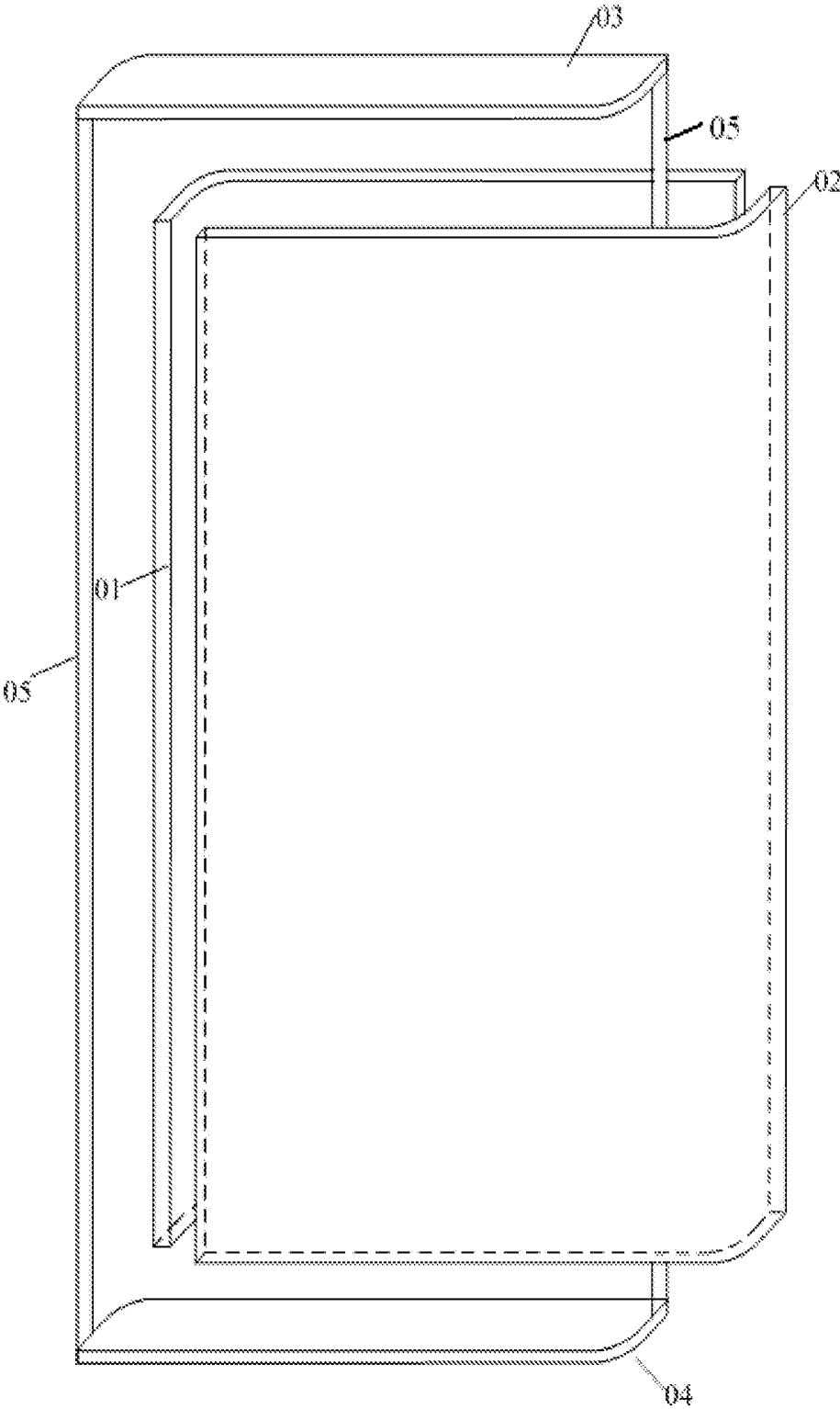

FIG. 3

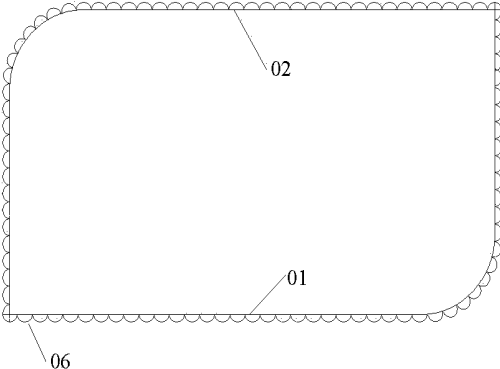

FIG. 4

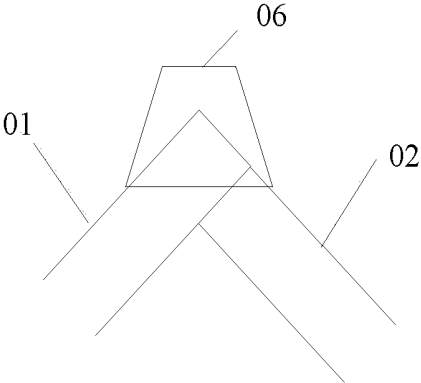

FIG. 5

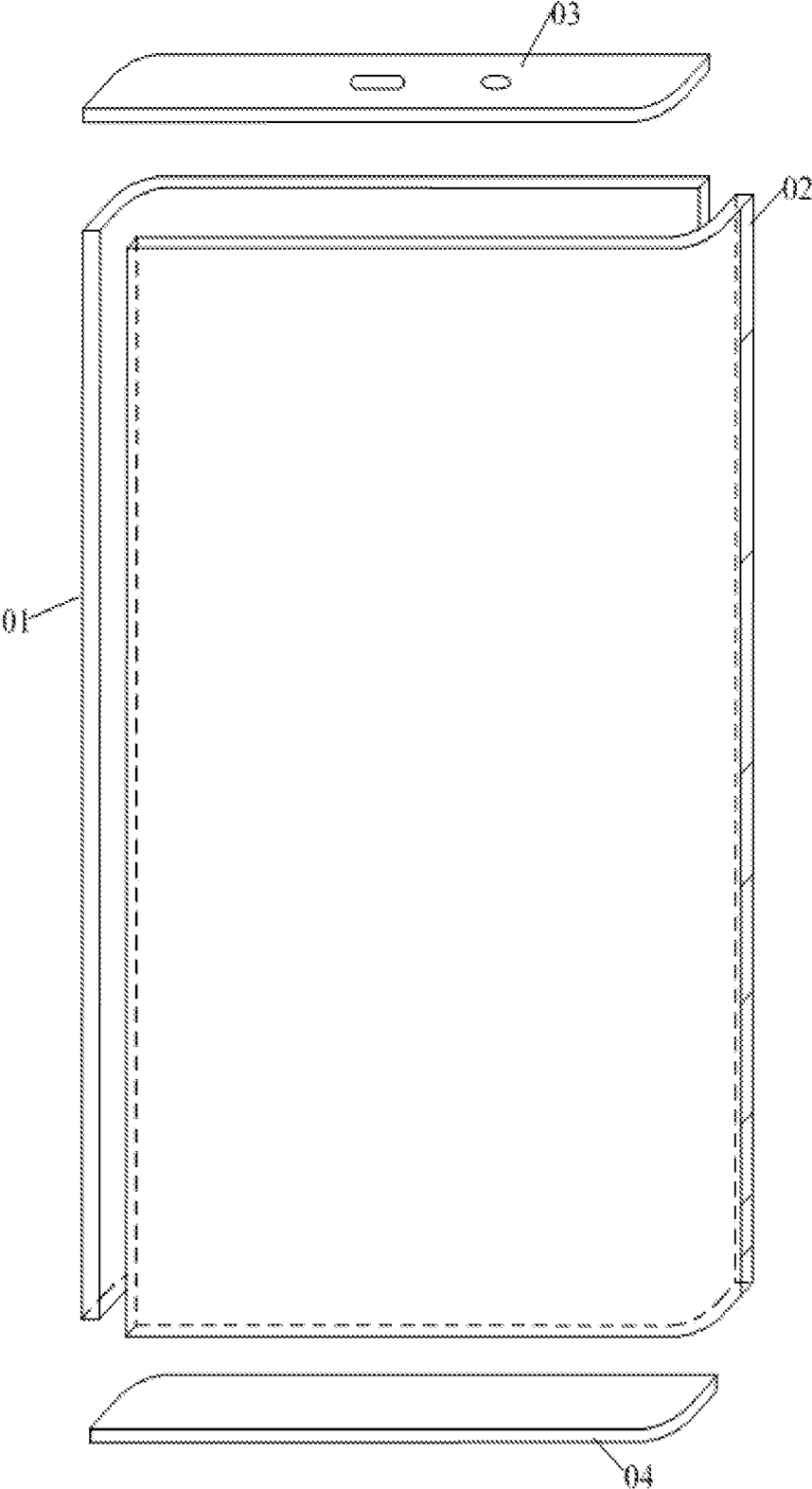

FIG. 6

MULTI-FACED DISPLAY DEVICE

FIELD OF THE DISCLOSURE

[0001] The present disclosure relates to the field of display technology, and particularly to a multi-faced display device.

BACKGROUND OF THE DISCLOSURE

[0002] As display devices are used in more fields, they have already not been limited to meet needs of planar display. Currently, there already occurs a design of a device capable of displaying on multiple faces. Such a multi-faced display device, for example, a lamp box, is generally formed by joining a plurality of planar display screens to perform display in respective directions. Such a multi-faced display device has edges at joining locations of respective display surfaces and cannot achieve continuity of images displayed in respective directions. In addition, in a context of ultra-slim design, due to a limited area of a lateral side, such a multi-faced display device cannot display specific information in a desired manner.

SUMMARY OF THE DISCLOSURE

[0003] In view of the above, embodiments of the present disclosure provide a multi-faced display device to achieve continuous display on multiple faces and display of specific information in a desired manner.

[0004] A multi-faced display device according to an embodiment of the present disclosure comprises a first display panel and a second display panel, wherein a lateral side of the first display panel curves toward a back side of a display region such that the first display panel forms an L-shaped structure, a lateral side of the second display panel curves towards a back side of a display region such that the second display panel forms an L-shaped structure, a lateral side of the first display panel opposite to the curved lateral side is encapsulated with the curved lateral side of the second display panel, and the curved lateral side of the first display panel is encapsulated with a lateral side of the second display panel opposite to the curved lateral side to form a closed structure, and a display surface of the multi-faced display device is an outside surface and/or inside surface of the closed structure.

[0005] In an optional implementation, the multi-faced display device further comprises a first encapsulating plate for sealing a top of the closed structure and a second encapsulating plate for sealing a bottom of the closed structure.

[0006] In an optional implementation, the first display panel and the second display panel, the first display panel and the first encapsulating plate, the first display panel and the second encapsulating plate, the second display panel and the first encapsulating plate, and the second display panel and the second encapsulating plate are assembled in a manner of press-fitting via a groove and a corresponding protrusion which are engaged with each other, of gluing, or of screwing.

[0007] In an optional implementation, the two lateral sides of the first display panel and second display panel are respectively encapsulated via a third encapsulating plate.

[0008] In an optional implementation, the third encapsulating plate, the first encapsulating plate and the second encapsulating plate are of an integral structure.

[0009] In an optional implementation, the multi-faced display device further comprises at least one function slot and/or physical function key, wherein the function slot and/or physical function key are disposed at an encapsulating location of the lateral sides of the first display panel and/or second display panel; or disposed at a non-display region of the first display panel and/or second display panel; or disposed on a surface of the first encapsulating plate and/or the second encapsulating plate.

[0010] In an optional implementation, the multi-faced display device further comprises a health monitoring unit configured to detect health information of a human body, wherein the health monitoring unit is disposed at an encapsulating location of the lateral sides of the first display panel and second display panel; or disposed at a non-display region of the first display panel and/or second display panel; or disposed on a surface of the first encapsulating plate and/or the second encapsulating plate.

[0011] In an optional implementation, the health monitoring unit is an infrared detecting unit and/or a minimal invasion detecting unit, the infrared detecting unit being configured to monitor a body temperature, the minimal invasion detecting unit being configured to monitor a blood sugar value.

[0012] In an optional implementation, the first display panel and second display panel comprise a main display surface and a non-main display surface, the non-main display surface being adapted to display health information detected by the health monitoring unit.

[0013] In an optional implementation, the first display panel and second display panel do not have a bezel at least at an encapsulating location of the lateral sides.

[0014] In an optional implementation, the first display panel and second display panel further comprise a circuit board, the circuit board of the first display panel and second display panel being connected to the display panels via a flexible electronic skin.

[0015] In an optional implementation, transparent prism structures for changing a direction of exit light are provided at least at an encapsulating location of lateral sides of the first display panel and second display panel.

[0016] In an optional implementation, the transparent prism structures at least partly protrude out of an outside surface of the closed structure, a cross section of the transparent prism structures perpendicular to the outside surface of the closed structure being in a semi-circular shape or an isosceles trapezoid shape.

[0017] In an optional implementation, the first display panel is a liquid crystal display panel, an organic electroluminescence display panel or an electronic paper display panel, and the second display panel is a liquid crystal display panel, an organic electroluminescence display panel or an electronic paper display panel.

[0018] In an optional implementation, the first display panel and second display panel are touch control display panels.

[0019] Advantageous effects of embodiments of the present disclosure include: as compared with a multi-faced display device formed by a plurality of planar display panels, the display device employing two

[0020] L-shaped display panels achieves a curved display surface resulting from connection of arcuate surfaces, thereby enhancing continuity of images displayed in respec-

tive directions of the multi-faced display device and providing a capability of displaying specific information in a desired manner.

BRIEF DESCRIPTION OF THE DRAWINGS

[0021] FIG. 1 is a first exploded view showing the structure of parts of a multi-faced display device according to an embodiment of the present disclosure;

[0022] FIG. 2 is a top view of the multi-faced display device according to an embodiment of the present disclosure;

[0023] FIG. 3 is a second exploded view showing the structure of parts of a multi-faced display device according to an embodiment of the present disclosure;

[0024] FIG. 4 is a structural schematic view of transparent prism structures of the multi-faced display device according to an embodiment of the present disclosure;

[0025] FIG. 5 is a structural schematic view of a transparent prism structure of the multi-faced display device according to an embodiment of the present disclosure; and

[0026] FIG. 6 is a third exploded view showing the structure of parts of a multi-faced display device according to an embodiment of the present disclosure.

DETAILED DESCRIPTION OF THE DISCLOSURE

[0027] A multi-faced display device provided by embodiments of the present disclosure is described in detail below with reference to the accompanying drawings. Shapes and sizes of parts shown in the drawings do not necessarily reflect a real proportion of the multi-faced display device and are only intended to illustrate the present disclosure.

[0028] As shown in FIG. 1, an embodiment of the present disclosure provides a multi-faced display device comprising a first display panel **01** and a second display panel **02**. A lateral side of the first display panel **01** curves toward a back side of a display region such that the first display panel **01** forms an L-shaped structure. A lateral side of the second display panel **02** curves towards a back side of a display region such that the second display panel **02** forms an L-shaped structure. A lateral side of the first display panel **01** opposite to the curved lateral side is encapsulated with the curved lateral side of the second display panel **02**, and the curved lateral side of the first display panel **01** is encapsulated with a lateral side of the second display panel **02** opposite to the curved lateral side to form a closed structure, as shown in a top view of FIG. 2.

[0029] Furthermore, the multi-faced display device further comprises a first encapsulating plate **03** for sealing a top of the closed structure and a second encapsulating plate **04** for sealing a bottom of the closed structure. The first encapsulating plate **03** and the second encapsulating plate **04** need to be arranged in a corresponding shape according to a cross-sectional shape of the closed structure so as to seal the top and bottom of the closed structure.

[0030] Display surfaces of the multi-faced display device may be outside surfaces of the closed structure, as shown by oblique lines in FIG. 2. Of course, in some applications of the display device, the display surfaces of the multi-faced display device may also be inside surfaces of the closed structure, or even both outside surfaces and inside surfaces may be arranged as the display surfaces. For example, in arrangement of an exhibition hall, an outer wall surface

and/or inner wall surface of the whole exhibition hall may be arranged as display surfaces of the multi-faced display device.

[0031] Noticeably, as shown in FIG. 1, an obliquely upward arrow indicates a rear surface of the closed structure, an obliquely downward arrow indicates a front surface of the closed structure, a leftward arrow indicates a left lateral surface of the closed structure, and a rightward arrow indicates a right lateral surface of the closed structure.

[0032] As can be seen from FIGS. 1 and 2, the closed structure of the multi-faced display device comprises four straight surfaces and two arcuate surfaces, and the straight surfaces in at least four directions (front, rear, left and right) and the two arcuate surfaces of the closed structure all can perform a function of displaying images. As compared with a multi-faced display device formed by a plurality of planar display panels, the display device according to the present disclosure employs two L-shaped display panels to achieve arcuate connection of two groups of display panels in two directions (front and right, rear and left), thereby enhancing continuity of images displayed in respective directions of the multi-faced display device. In addition, as compared with a multi-faced display device with an arcuate surface for connection at each of four corners, the embodiment of the present disclosure trades off between continuity of displayed images and difficulty for manufacturing the display device. Because only one arcuate display surface needs to be processed for each of the first display panel **01** and the second display panel **02**, the processing and assembling of the display device becomes easier.

[0033] Upon implementation, a proportion of lengths b and a of two adjacent straight surfaces of the multi-faced display device may be adjusted according to an application scenario of the multi-faced display device so that a profile of the multi-faced display device approximates a column-shaped structure having a rectangular cross section or a square cross section. When the multi-faced display device is applied to a mobile terminal such as a mobile phone, the front and rear surfaces may be arranged as having larger areas and left and right lateral surfaces be arranged narrower to facilitate an ultra-slim design of the mobile terminal. In this case, the display surface of the multi-faced display device is generally an outside surface of the closed structure. In addition, integral parts of the mobile terminal such as a power supply and a circuit board may be mounted inside the closed structure of the multi-faced display device so that the outer surface of the mobile terminal forms a whole on which images may be displayed. When the multi-faced display device is applied to for example a 3D display wall for 3D multi-face display, the front and rear surfaces and left and right lateral surfaces may be set as having substantially the same area. In this case, the display surface of the multi-faced display device may be the outside surface and/or inside surface of the closed structure.

[0034] Additionally, an angle α between the two adjacent straight surfaces of the multi-faced display device may be adjusted as needed. Generally, to achieve excellent continuity of images displayed on respective display surfaces of the multi-faced display device, the angle α is generally selected as an obtuse or right angle. FIG. 2 exemplarily illustrates that the angle α is a right angle.

[0035] Upon implementation, at least one display surface of the multi-faced display device may be set as a main display surface according to the application scenario of the

multi-faced display device. For example, when the multi-faced display device is applied to a mobile terminal such as a mobile phone, the front surface of the first display panel **01** and the rear surface of the second display panel **02** may be used as main display surfaces. In this case, a working state of the multi-faced display device may be set in the following several types:

[0036] 1. The two main display surfaces display the same content simultaneously, e.g., the front surface and rear surface may display the same image simultaneously;

[0037] 2. The two main display surfaces display different content respectively, e.g., the front surface displays an image of a front side of a human body whilst the rear surface displays an image of a back side of the human body;

[0038] 3. Only one of the main display surfaces displays content while other display surfaces are in an OFF state;

[0039] 4. A plurality of non-main display surfaces (e.g., a left lateral surface, a right lateral surface, a curved transition surface joining the left lateral surface to the rear surface, and/or a curved transition surface joining the right lateral surface and the front surface) display the same content simultaneously;

[0040] 5. The plurality of non-main display surfaces display different content respectively; and

[0041] 6. Only one of the plurality of non-main display surfaces displays content while other display surfaces are in an OFF state.

[0042] Furthermore, the plurality of non-main display surfaces may be combined into a single entire non-main display surface. For instance, the left lateral surface and the curved transition surface joining the left lateral surface to the rear surface may be combined into a single display surface, and the right lateral surface and the curved transition surface joining the right lateral surface to the front surface may be combined into a single display surface.

[0043] Some UI icons for function keys, APPs or the like may be displayed on the non-main display surfaces according to arrangement. For example, function buttons may be displayed on the left lateral surface, right lateral surface, the curved transition surface joining the left lateral surface to the rear surface, or the curved transition surface joining the right lateral surface and the front surface. Specific information such as information associated with personal attributes of the user may also be displayed on the non-main display surfaces (discussed below).

[0044] Arrangement and working states of the main display surfaces and non-main display surfaces are described only by way of example, and not limitation. Upon implementation, the first display panel **01** and the second display panel **02** may, as a whole, display the same content, or display different content in regions.

[0045] Upon implementation, the first display panel **01** and second display panel **02** of the multi-faced display device may be made from a touch control display panel such that it is convenient for the user to directly perform corresponding operations with the touch control display panel when the function buttons are displayed. Of course, the first display panel **01** and second display panel **02** may also be non-touch control display panels, which is not limited here.

[0046] In particular, when the multi-faced display device is applied to a display wall, the first display panel and second display panel may also be produced as transparent display panels. As such, some articles may be placed in the closed structure formed by the first display panel **01** and second

display panel **02** for exhibition, and correspondingly, the first display panel **01** and second display panel **02** may display related information such as introductory content of the exhibited articles so that the user may view it through the touch control function of the multi-faced display device. When the multi-faced display device is applied to a mobile terminal such as a mobile phone, the first display device and second display device are generally arranged as opaque display panels.

[0047] Upon implementation, the first display panel **01** of the multi-faced display device may specifically be a liquid crystal display panel, an organic electroluminescence display panel or an electronic paper display panel. Correspondingly, the second display panel **02** may specifically be a liquid crystal display panel, an organic electroluminescence display panel or an electronic paper display panel.

[0048] As the first display panel **01** and second display panel **02** need to be subjected to curving treatment, a flexible substrate needs to be selected to fabricate the first display panel **01** and second display panel **02**, and this flexible substrate comprises a glass substrate. In addition, a material of a corresponding functional film layer also needs to have corresponding flexibility to ensure that certain curving treatment may be performed for the first display panel **01** and the second display panel **02**.

[0049] Upon implementation, in fabricating the multi-faced display device, many assembling manners may be employed between the first display panel **01** and second display panel **02**, between the first display panel **01** and the first encapsulating plate **03**, between the first display panel **01** and second encapsulating plate **04**, between the second display panel **02** and the first encapsulating plate **03**, and between the second display panel **02** and the second encapsulating plate **04**. Specifically, the assembling manner may be a press-fitting manner via a groove and a corresponding protrusion which are engaged with each other, a gluing manner or a screwing manner, and is not limited here.

[0050] Encapsulating the first display panel **01** and second display panel **02** by press-fitting or gluing may facilitate use of a bezel-less design at locations of encapsulation at the lateral sides of the first display panel **01** and second display panel **02**. For example, in fabricating the first display panel **01** and second display panel **02**, the left and right lateral sides thereof may be made bezel-less such that the first display panel **01** and second display panel **02** do not have a bezel at least at locations of encapsulation at the lateral sides.

[0051] With the press-fitting manner or gluing manner being used, wires might be arranged at joints between the first display panel **01** and second display panel **02** so that it becomes difficult to engage the first display panel **01** and second display panel **02** seamlessly. To simplify the encapsulating process, the two lateral sides of the first display panel **01** and second display panel **02** may be respectively encapsulated via a third encapsulating plate **05**, as shown in FIG. 3. A circuit may be disposed on the third encapsulating plate **05** to provide a lead wire or interface so as to simplify the process.

[0052] Furthermore, the third encapsulating plate **05**, the first encapsulating plate **03** and the second encapsulating plate **04** may be of an integral structure so that the integral structure, the first display panel **01** and second display panel **02** may be directly assembled together when the multi-faced display device is assembled.

[0053] Generally, the first display panel **01** and second display panel **02** further comprise a circuit board. To ensure connection between the circuit board and a display region of the first display panel **01** and second display panel **02**, they both are connected via a flexible electronic skin which generally may be made of a rubber net-like conductive material. When the electronic skin is used to connect the display region with the circuit board, a bezel-less design may be used for all of upper and lower bezels and bezels at locations of encapsulation of lateral sides of the first display panel **01** and second display panel **02** to enable the finally-assembled multi-faced display device to implement truly bezel-less annular display.

[0054] Furthermore, an optical design may be added to the multi-faced display device so that a viewer visually cannot see the encapsulating bezels of the first display panel **01** and second display panel **02**. Specifically, as shown in FIG. 4, transparent prism structures **06** for changing a direction of exit light may be fabricated at an encapsulating location of lateral sides of the first display panel **01** and second display panel **02**. The transparent prism structures **06** may refract light originally exiting forward at the encapsulating location of the lateral sides of the first display panel **01** and second display panel **02** to the encapsulating location of the lateral sides so that the viewer visually cannot perceive existence of the seam, and visually bezel-less annular display can be achieved.

[0055] Noticeably, when the organic electroluminescence display panel is used to fabricate the first display panel and second display panel, thin film encapsulating technology of the organic electroluminescence display panel may be used to achieve a physically bezel-less design. When the liquid crystal display panel or electronic paper display panel is used to fabricate the first display panel or second display panel, the optically bezel-less effect is achieved relying on for example the optical design (i.e., the transparent prism structures) since the encapsulating technology of the liquid crystal display panel or electronic paper display panel cannot achieve true physically bezel-less design. Of course, the bezel-less effect may also be optimized by virtue of for example the optical design when the organic electroluminescence display panel is used to fabricate the first display panel and second display panel.

[0056] Upon implementation, the transparent prism structures **06** may be disposed only at the encapsulating location of the lateral sides of the first display panel **01** and second display panel **02**. Alternatively, as shown in FIG. 4, the transparent prism structures **06** may also be disposed on all external surfaces of the first display panel **01** and second display panel **02**, which will not be limited here.

[0057] The transparent prism structures **06** disposed at the encapsulating location of the lateral sides of the first display panel **01** and second display panel **02** should at least partly protrude out of the outside surface of the closed structure, namely, the outside surface of the first display panel **01** and second display panel **02**, as shown in FIG. 5. A cross section of the transparent prism structures **06** perpendicular to the outside surface of the closed structure (i.e., the outside surface of the first display panel **01** and second display panel **02**) may be set in a shape such as a semi-circular shape as shown in FIG. 4 or an isosceles trapezoid shape as shown in FIG. 5 so as to change the exit direction of the light.

[0058] In addition, as shown in FIG. 6, the above multi-faced display device provided by the embodiment of the

present disclosure may further comprise at least one function slot and/or physical function key. Specifically, the function slot may be an SD card slot, a SIM card slot, a USB insertion slot, an earphone slot, a charging slot and the like; the physical function key may be a switch button, a volume tuning button, a brightness regulating button and the like. When the aforesaid multi-faced display device has a bezel, the above function slot and/or physical function key may be disposed at the encapsulating location of the lateral sides of the first display panel **01** and second display panel **02**. Specifically, the function slot and/or physical function key may only be disposed at the encapsulating location of one of the lateral sides, or disposed at the encapsulating location of both of the lateral sides. Alternatively, it may also be disposed at the non-display region of the first display panel **01** and/or second display panel **02**. When the aforesaid multi-faced display device according to the embodiment of the present disclosure is bezel-less, the function slot and/or physical function key may be disposed on a surface of the first encapsulating plate **03** and/or the second encapsulating plate **04**. FIG. 6 shows two physical function keys disposed on the first encapsulating plate **03**, and a plurality of function slots disposed at the encapsulating location of one of lateral sides of the first display panel **01** and second display panel **02**.

[0059] Furthermore, when the multi-faced display device according to the embodiment of the present disclosure is for example applied to a mobile terminal such as a mobile phone, the multi-faced display device is adapted to display specific information. Since the mobile terminal such as the mobile terminal is associated with personal attributes of the user, the multi-faced display device may be used to display information related to personal attributes of the user in addition to information related to functions (e.g., call, messaging, video playback) of the mobile terminal itself.

[0060] Upon implementation, the multi-faced display device according to the embodiment of the present disclosure may comprise a health monitoring unit configured to detect health information of a human body and display corresponding health information (e.g., body temperature, blood sugar value and the like) on the display surfaces of the multi-faced display device. Since such health information is usually only several groups of digits and does not need to occupy a large screen region, it may be displayed using non-main display surfaces of the multi-faced display device. As such, the display region of the main display surface need not be occupied, so the user may monitor the health information while normally viewing other display content on the main display surface. The multi-faced display device according to the embodiment of the present disclosure is advantageous in displaying such health information in that the left side surface or right side surface and the corresponding curved transition surface may be combined into a single non-main display surface to enlarge the area of the display area so that such information may also be clearly displayed on the non-main display surface even though the ultra-slim design is employed. This enhances flexibility of product design and user's use experience. Particularly, it is usually desirable to monitor the health information constantly in a long term and maintain the display of the health information. Hence, power may be saved by keeping the non-main display surface displaying the health information on and turning off other display surfaces. Alternatively or additionally, such health information may be displayed on the main

display surfaces depending on a location of the health monitoring unit, the user's selection or a specific use environment.

[0061] When the multi-faced display device according to the embodiment of the present disclosure has certain bezels, the health monitoring unit may be disposed at the encapsulating location at the lateral side of the first display panel **01** and/or second display panel **02**. Specifically, the health monitoring unit may only be disposed at the encapsulating location of one of the lateral sides, or disposed at the encapsulating location of both of the lateral sides. Alternatively, it may also be disposed at the non-display region of the first display panel **01** and/or second display panel **02**. When the multi-faced display device according to the embodiment of the present disclosure is bezel-less, the health monitoring unit may be disposed on a surface of the first encapsulating plate **03** and/or the second encapsulating plate **04**.

[0062] Generally, the health monitoring unit has a data collecting component and a data analyzing and storing component. Specifically, the data collecting component may employ a sensor such as an infrared sensor; the data analyzing and storing component may employ hardware such as a micro controller unit (MCU) and a digital signal processor (DSP). Such hardware has an on-chip storage device for storing program and data. Certainly, an off-chip storage device may also be used as a storing component. In an example, the health monitoring unit may be an infrared detecting unit and/or a minimal invasion detecting unit, wherein the infrared detecting unit is configured to monitor a body temperature and the minimal invasion detecting unit is configured to monitor a blood sugar value. Other types of monitoring units may also be employed for specific objects to be monitored.

[0063] Furthermore, when the multi-faced display device according to the embodiment of the present disclosure is applied to an IT display product, a TV set, a mobile phone or the like, an image acquiring means such as a camera and means such as a Blue-tooth means may also be disposed on the non-display regions of the first display panel **01** and/or second display panel **02**. This is not for limitation here.

[0064] As compared with the multi-faced display device formed by a plurality of planar display panels, the display device according to the embodiment of the present disclosure employs two L-shaped display panels to achieve a curved display surface resulting from connection via arcuate surfaces, thereby enhancing continuity of images displayed in respective directions of the multi-faced display device and providing a capability of displaying specific information in a desired manner.

[0065] Apparently, various modifications and variations to the present disclosure may be made by those skilled in the art may make without departing from the spirit and scope of the present disclosure. As such, if such modifications and variations to the present disclosure fall within the scope of claims of the present disclosure and equivalents thereof, the present disclosure is intended to include such modifications and variations.

1. A multi-faced display device, comprising:

a first display panel having a first lateral side and a second lateral side opposite to the first lateral side, the first lateral side curving towards a back side of the first display panel such that the first display panel forms an L-shaped structure; and

a second display panel having a first lateral side and a second lateral side opposite to the first lateral side, the first lateral side curving towards a back side of the second display panel such that the second display panel forms an L-shaped structure;

wherein the second lateral side of the first display panel is encapsulated with the first lateral side of the second display panel and the first lateral side of the first display panel is encapsulated with the second lateral side of the second display panel to form a closed structure, an outside surface and/or inside surface of the closed structure being a display surface of the multi-faced display surface.

2. The multi-faced display device according to claim 1, further comprising a first encapsulating plate for sealing a top of the closed structure and a second encapsulating plate for sealing a bottom of the closed structure.

3. The multi-faced display device according to claim 2, wherein the first display panel and the second display panel, the first display panel and the first encapsulating plate, the first display panel and the second encapsulating plate, the second display panel and the first encapsulating plate, and the second display panel and the second encapsulating plate are assembled in a manner of press-fitting via a groove and a corresponding protrusion which are engaged with each other, of gluing, or of screwing.

4. The multi-faced display device according to claim 2, wherein the second lateral side of the first display panel is encapsulated with the first lateral side of the second display panel via a third encapsulating plate, and the first lateral side of the first display panel is encapsulated with the second lateral side of the second display panel via another third encapsulating plate.

5. The multi-faced display device according to claim 4, wherein the two third encapsulating plates, the first encapsulating plate and the second encapsulating plate are of an integral structure.

6. The multi-faced display device according to claim 2, further comprising at least one function slot and/or physical function key, wherein the function slot and/or physical function key are disposed at an encapsulating location of the lateral sides of the first display panel and/or second display panel; or disposed at a non-display region of the first display panel and/or second display panel; or disposed on a surface of the first encapsulating plate and/or the second encapsulating plate.

7. The multi-faced display device according to claim 2, further comprising a health monitoring unit configured to detect health information of a human body, wherein the health monitoring unit is disposed at an encapsulating location of the lateral sides of the first display panel and/or second display panel; or disposed at a non-display region of the first display panel and/or second display panel; or disposed on a surface of the first encapsulating plate and/or the second encapsulating plate.

8. The multi-faced display device according to claim 7, wherein the health monitoring unit is an infrared detecting unit and/or a minimal invasion detecting unit, the infrared detecting unit being configured to monitor a body temperature, the minimal invasion detecting unit being configured to monitor a blood sugar value.

9. The multi-faced display device according to claim 7, wherein each of the first display panel and second display panel comprises a main display surface and a non-main

display surface, the non-main display surface being adapted to display the health information detected by the health monitoring unit.

10. The multi-faced display device according to claim **1**, wherein the first display panel and second display panel do not have a bezel at least at an encapsulating location of the lateral sides.

11. The multi-faced display device according to claim **10**, further comprising a circuit board connected to the first display panel and/or the second display panel via a flexible electronic skin.

12. The multi-faced display device according to claim **10**, further comprising a plurality of transparent prism structures provided at least at the encapsulating location of lateral sides of the first display panel and second display panel, each of which for changing a direction of exit light.

13. The multi-faced display device according to claim **12**, wherein each of the plurality of transparent prism structures at least partly protrudes out of an outside surface of the closed structure, a cross section of each transparent prism structures- perpendicular to the outside surface of the closed structure being in a semi-circular shape or an isosceles trapezoid shape.

14. The multi-faced display device according to claim **1**, wherein the first display panel is a liquid crystal display panel, an organic electroluminescence display panel or an electronic paper display panel, and the second display panel is a liquid crystal display panel, an organic electroluminescence display panel or an electronic paper display panel.

15. The multi-faced display device according to claim **14**, wherein the first display panel and second display panel are touch control display panels.

16. The multi-faced display device according to claim **2**, wherein the first display panel is a liquid crystal display panel, an organic electroluminescence display panel or an electronic paper display panel, and the second display panel is a liquid crystal display panel, an organic electroluminescence display panel or an electronic paper display panel.

17. The multi-faced display device according to claim **4**, wherein the first display panel is a liquid crystal display panel, an organic electroluminescence display panel or an electronic paper display panel, and the second display panel is a liquid crystal display panel, an organic electroluminescence display panel or an electronic paper display panel.

18. The multi-faced display device according to claim **6**, wherein the first display panel is a liquid crystal display panel, an organic electroluminescence display panel or an electronic paper display panel, and the second display panel is a liquid crystal display panel, an organic electroluminescence display panel or an electronic paper display panel.

19. The multi-faced display device according to claim **7**, wherein the first display panel is a liquid crystal display panel, an organic electroluminescence display panel or an electronic paper display panel, and the second display panel is a liquid crystal display panel, an organic electroluminescence display panel or an electronic paper display panel.

20. The multi-faced display device according to claim **10**, wherein the first display panel is a liquid crystal display panel, an organic electroluminescence display panel or an electronic paper display panel, and the second display panel is a liquid crystal display panel, an organic electroluminescence display panel or an electronic paper display panel.

* * * * *

专利名称(译)	多面显示设备		
公开(公告)号	US20170153669A1	公开(公告)日	2017-06-01
申请号	US14/785564	申请日	2015-05-28
[标]申请(专利权)人(译)	京东方科技集团股份有限公司 北京京东方光电科技有限公司		
申请(专利权)人(译)	京东方科技集团股份有限公司. 北京京东方光电科技有限公司.		
当前申请(专利权)人(译)	北京京东方光电科技有限公司. 京东方科技集团股份有限公司.		
[标]发明人	WANG JIAHENG BAI FENG YANG JIUXIA		
发明人	WANG, JIAHENG BAI, FENG YANG, JIUXIA		
IPC分类号	G06F1/16 A61B5/145 A61B5/00 A61B5/01		
CPC分类号	G06F1/1647 G06F1/1652 A61B5/015 A61B2562/06 A61B5/7445 A61B5/0075 A61B2560/0462 A61B5/14532 A61B5/1455 G02F1/133308 G02F1/13336 G02F1/13338 G02F2001/133342 G02F2201/44 G06F1/1626 G06F1/1637 G06F3/03547 G06F2203/04102 G09F9/33 G09F9/35 H04M1/0266 H04M1/0268		
优先权	201410773839.9 2014-12-12 CN		
其他公开文献	US10095271		
外部链接	Espacenet USPTO		

摘要(译)

本发明公开了一种多面显示装置，包括第一显示面板和第二显示面板，其中，第一显示面板和第二显示面板中的每一个都设置有朝向显示区域的后侧弯曲的侧面。形成L形结构，第一显示面板的与弯曲侧面相对的侧面被第二显示面板的弯曲侧面封装，并且第一显示面板的弯曲侧面被封装有侧面第二显示面板与弯曲侧面相对，形成封闭结构，多面显示装置的显示面是封闭结构的外表面。可以在至少四个方向上在多面显示设备的封闭结构的表面上实现显示图像的功能；此外，显示装置采用两个L形显示面板以实现曲面显示表面，该曲面显示表面是通过两个方向经由弧形表面连接两组显示表面而得到的，从而增强了在多面显示装置的各个方向上显示的图像的连续性。与由多个平面显示板形成的多面显示装置相比，多个平面显示板在多个表面上显示时具有多个边缘。

