



US 20160338635A1

(19) **United States**

(12) **Patent Application Publication**
JOHNSON et al.

(10) **Pub. No.: US 2016/0338635 A1**

(43) **Pub. Date: Nov. 24, 2016**

(54) **REDUCING BLOCKAGES OF A PLAQUE
DETECTION STREAM PROBE**

Publication Classification

(71) Applicant: **KONINKLIJKE PHILIPS N.V.**,
Eindhoven (NL)

(51) **Int. Cl.**
A61B 5/00 (2006.01)
A61C 17/22 (2006.01)
A61C 17/20 (2006.01)
A61C 17/02 (2006.01)
A61C 1/00 (2006.01)

(72) Inventors: **MARK THOMAS JOHNSON**,
ARENDONK (BE); **JOHANNES
HENDRIKUS MARIA SPRUIT**,
WAALRE (NL); **MENNO WILLEM
JOSE PRINS**, ROSMALEN (NL);
STEVEN CHARLES DEANE,
CAMBRIDGE (GB); **PIETER
HORSTMAN**, WEERT (NL); **EDGAR
MARTINUS VAN GOOL**, VEGHEL
(NL); **OKKE OUWELTJES**,
VELDHOVEN (NL)

(52) **U.S. Cl.**
CPC *A61B 5/4547* (2013.01); *A61C 17/0202*
(2013.01); *A61C 1/0015* (2013.01); *A61C
17/20* (2013.01); *A61C 17/221* (2013.01)

(21) Appl. No.: **15/114,558**

(22) PCT Filed: **Jan. 21, 2015**

(86) PCT No.: **PCT/EP2015/051042**

§ 371 (c)(1),

(2) Date: **Jul. 27, 2016**

(57) **ABSTRACT**

A proximal body portion (210) of a detection apparatus for detecting the presence of a substance on a surface includes pump portion (124, 142) and a proximal probe portion (111, 120) in fluid communication with one another. A controller (225) processes signal readings sensed by the parameter sensor (P, P1 or P2) and determines whether the signal readings are indicative of a substance (116) obstructing the passage of fluid (130) through the open port of the distal tip (112, 112') of a distal probe portion (110) of the detection apparatus (100, 100', 100'', 100''a, 100''b, 100''c, 100''d, 100c). The controller (225) transmits a signal that changes dynamic pressure at the distal tip (112, 112') upon determining that the signal readings are indicative of a substance (116) obstructing the passage of fluid (130) through the open port of the distal tip (112, 112').

(30) **Foreign Application Priority Data**

Jan. 30, 2014 (EP) 14153279.6

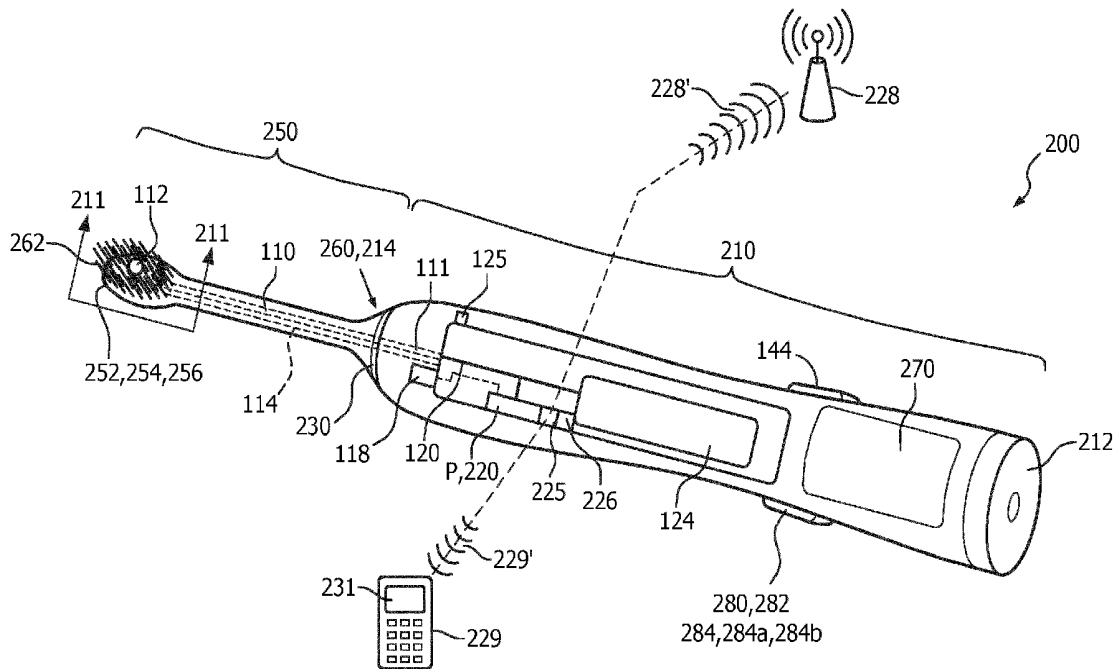

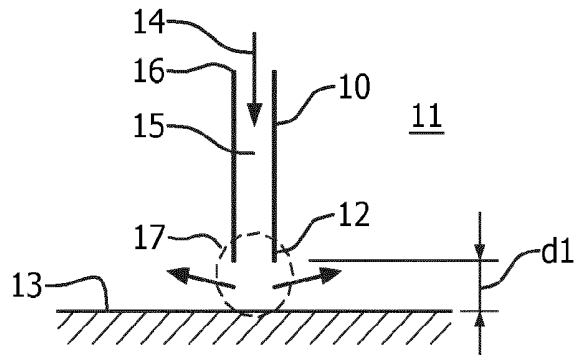

FIG. 1

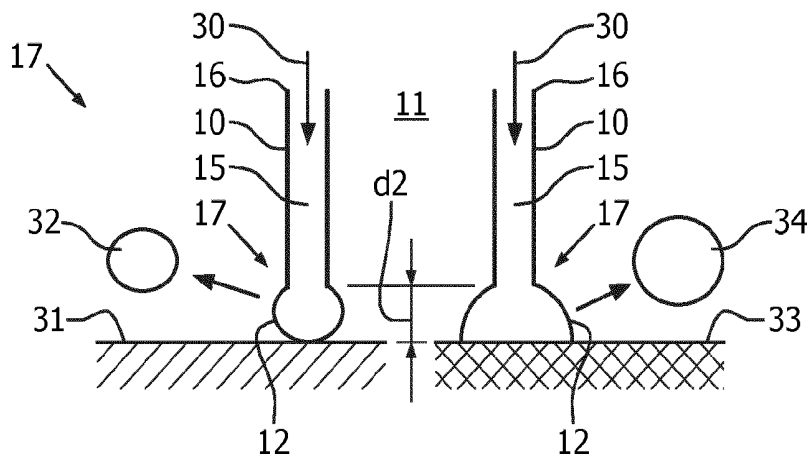

FIG. 2

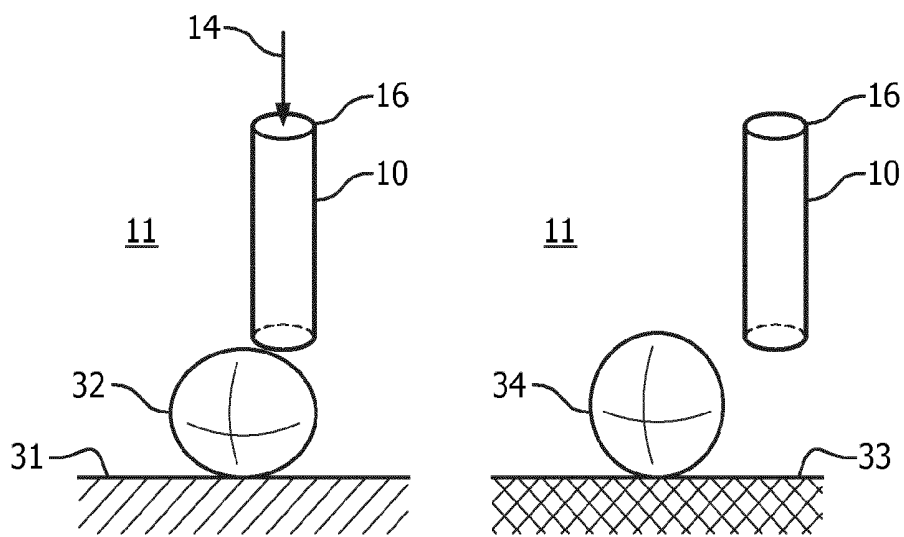

FIG. 3

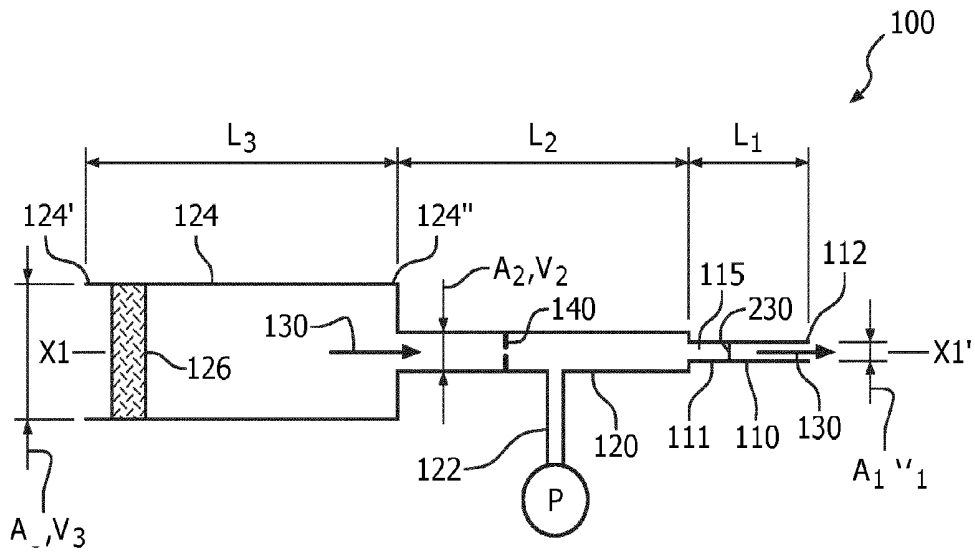

FIG. 4A

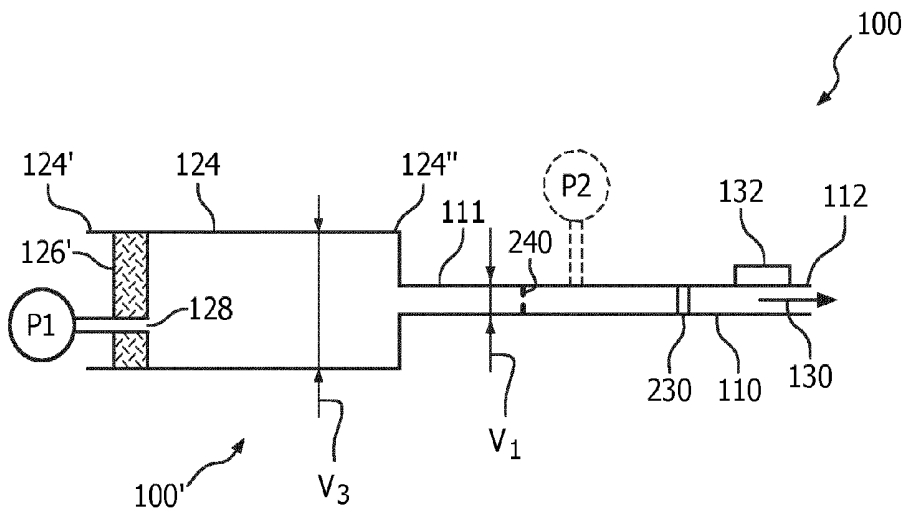

FIG. 4B

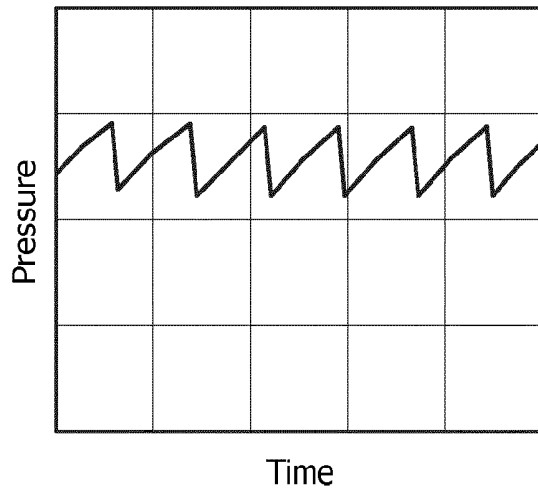

FIG. 5

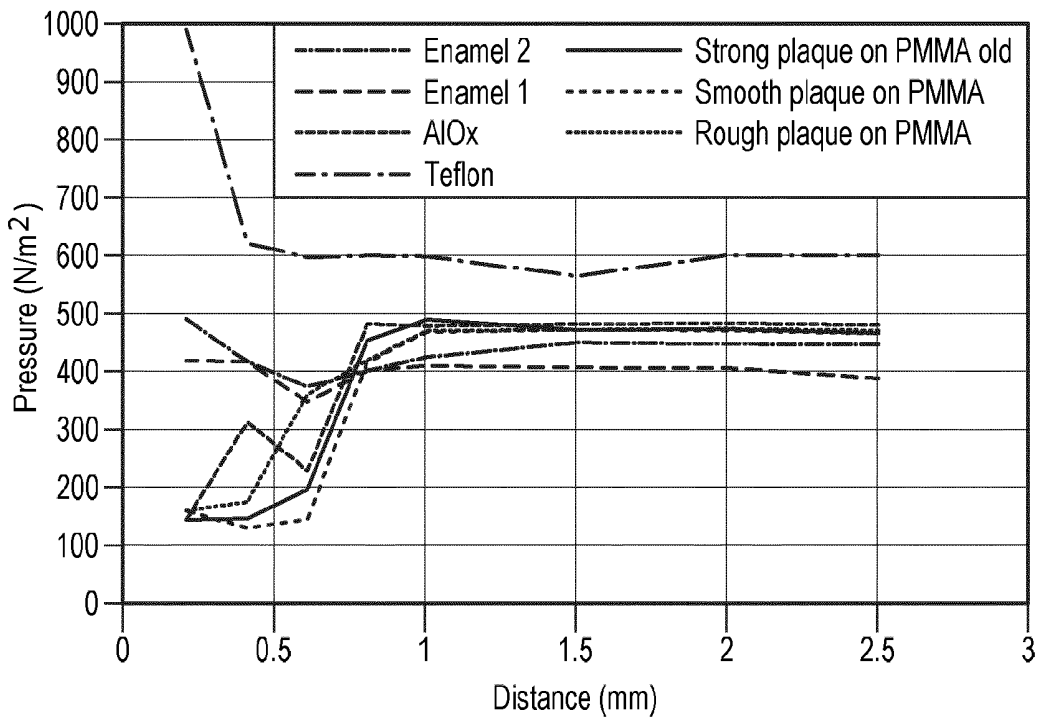

FIG. 6

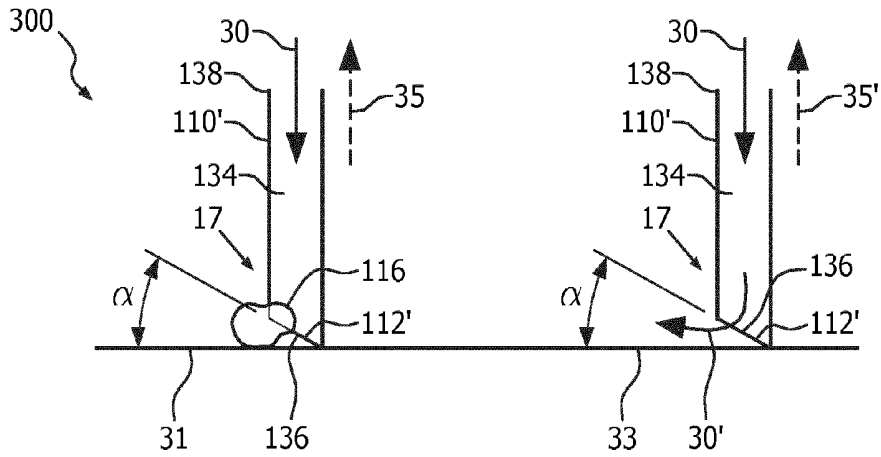

FIG. 7

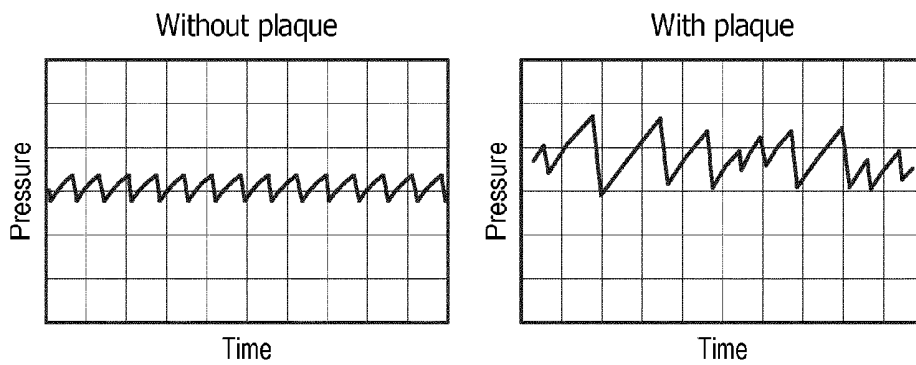

FIG. 8

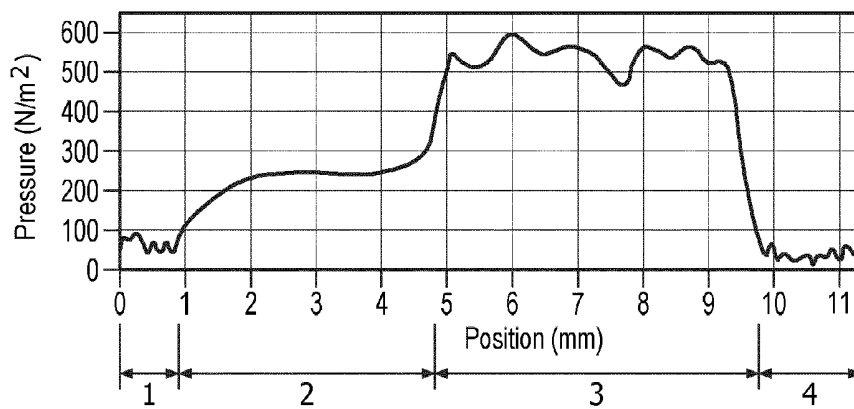

FIG. 9

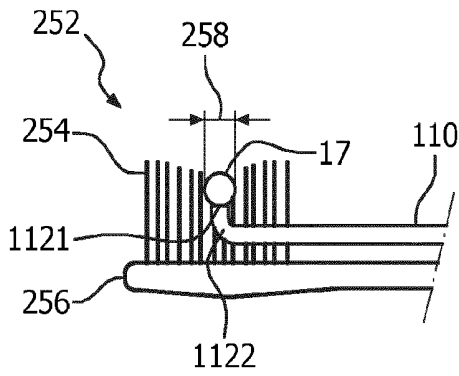

FIG. 11

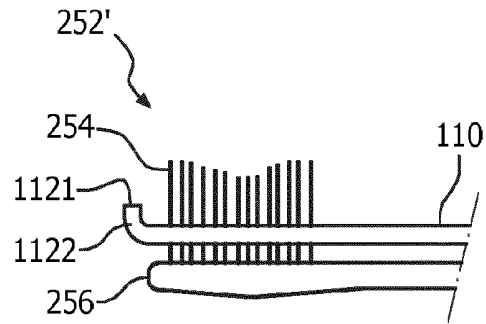

FIG. 12

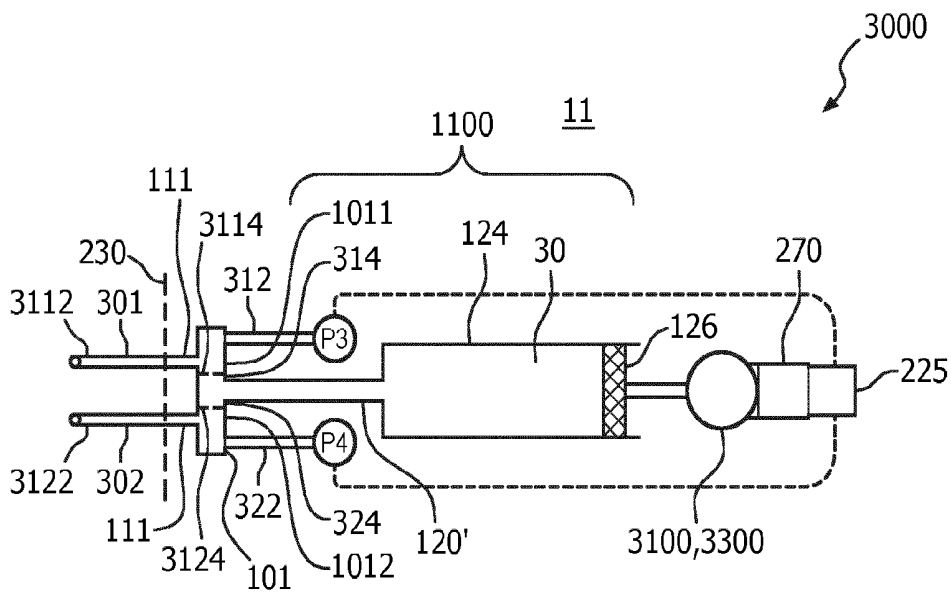

FIG. 13

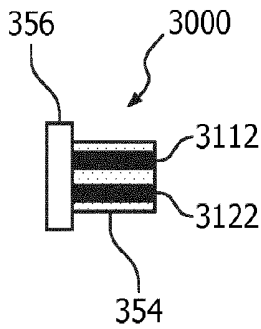

FIG. 16

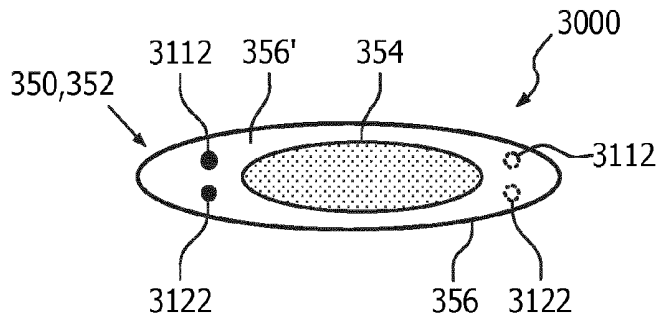

FIG. 14

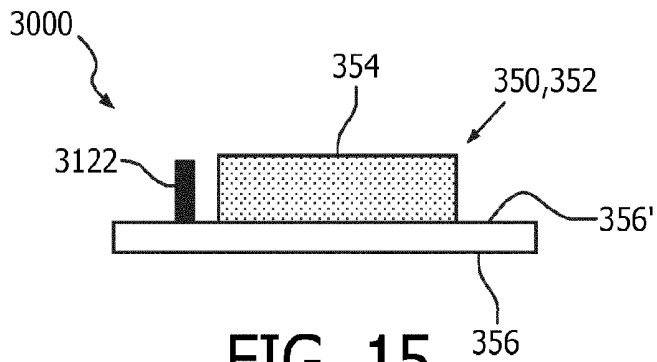

FIG. 15

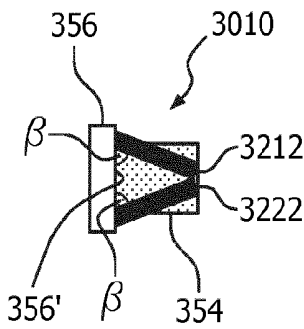

FIG. 19

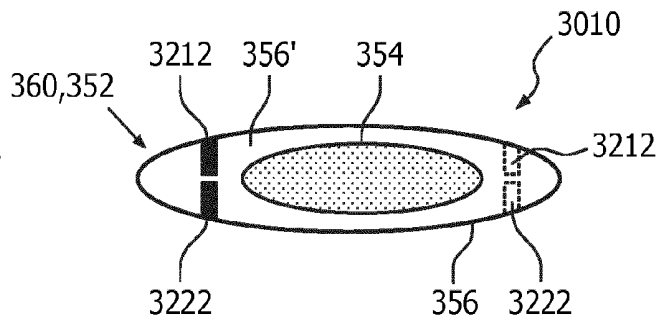

FIG. 17

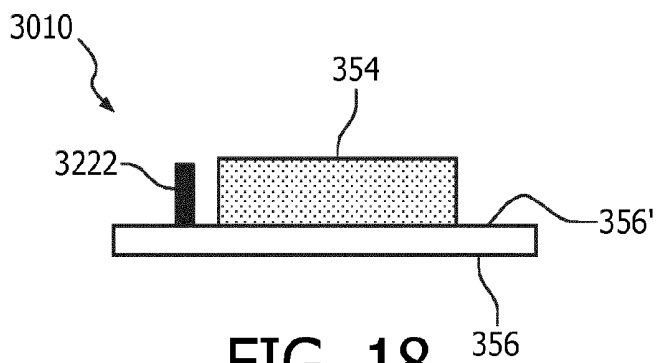

FIG. 18

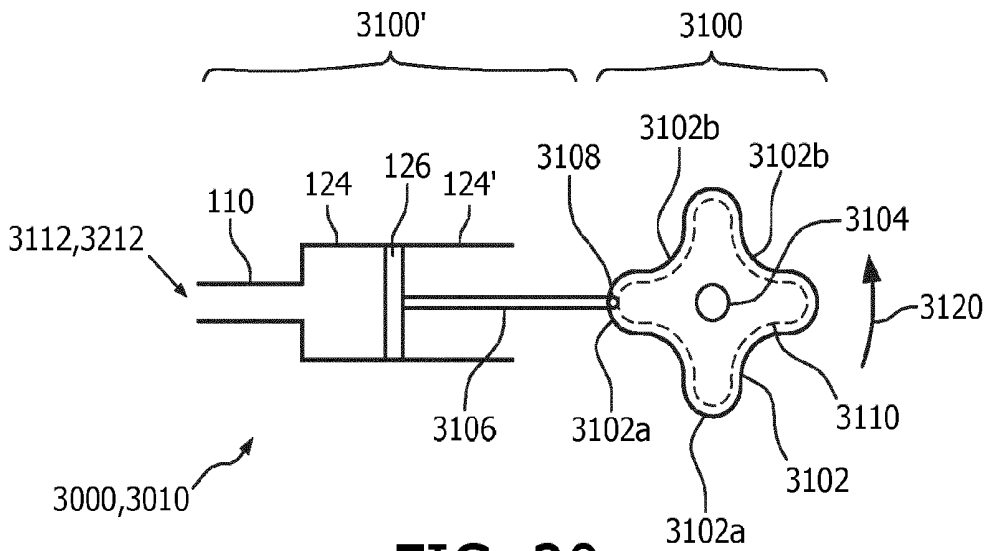

FIG. 20

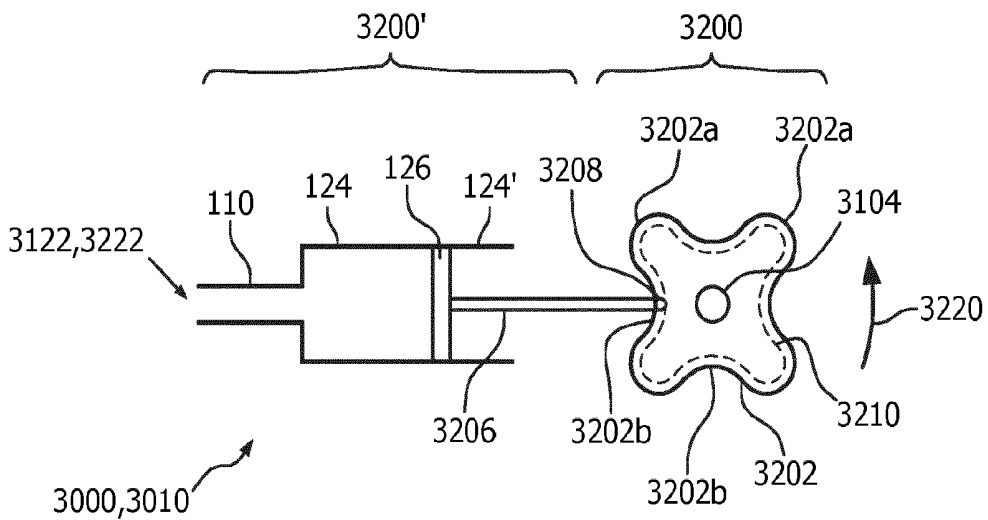

FIG. 21

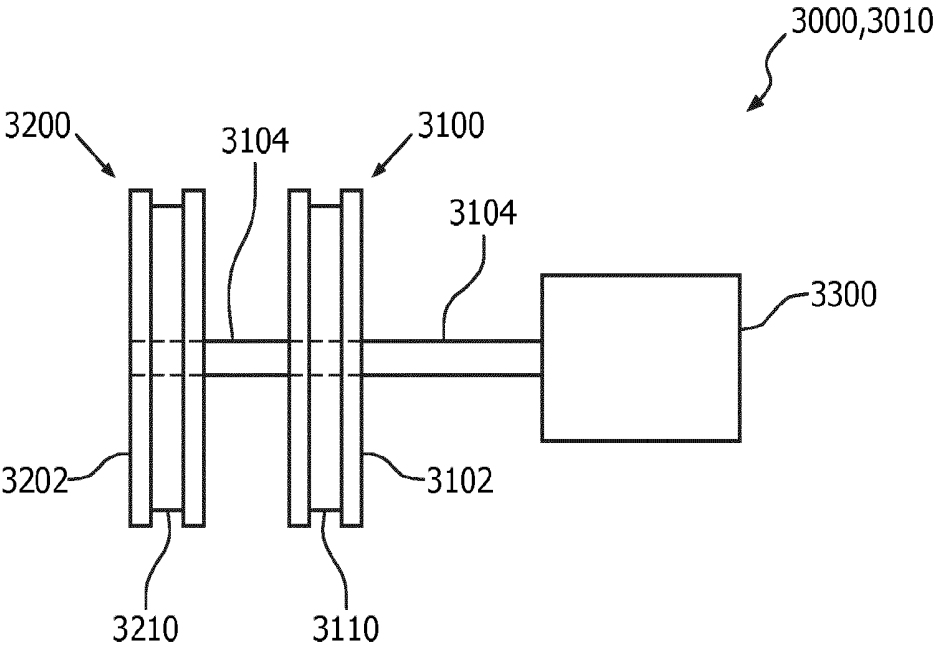

FIG. 22

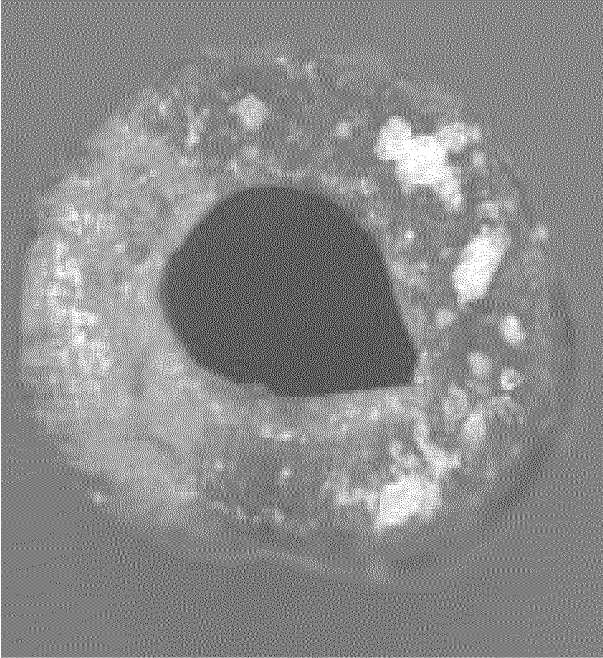

FIG. 23

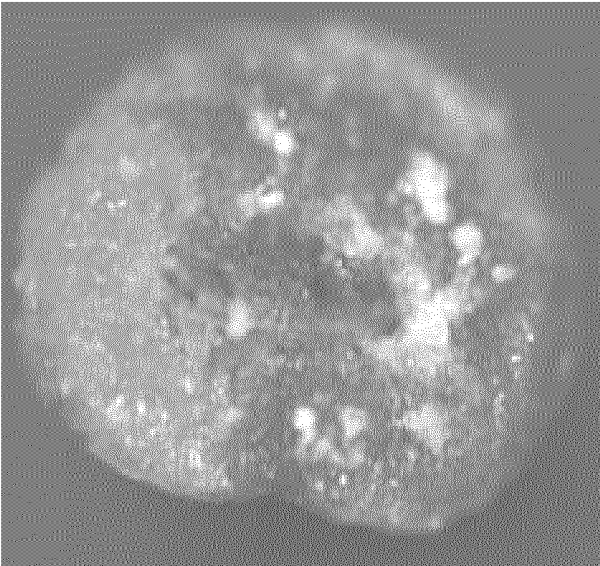

FIG. 24

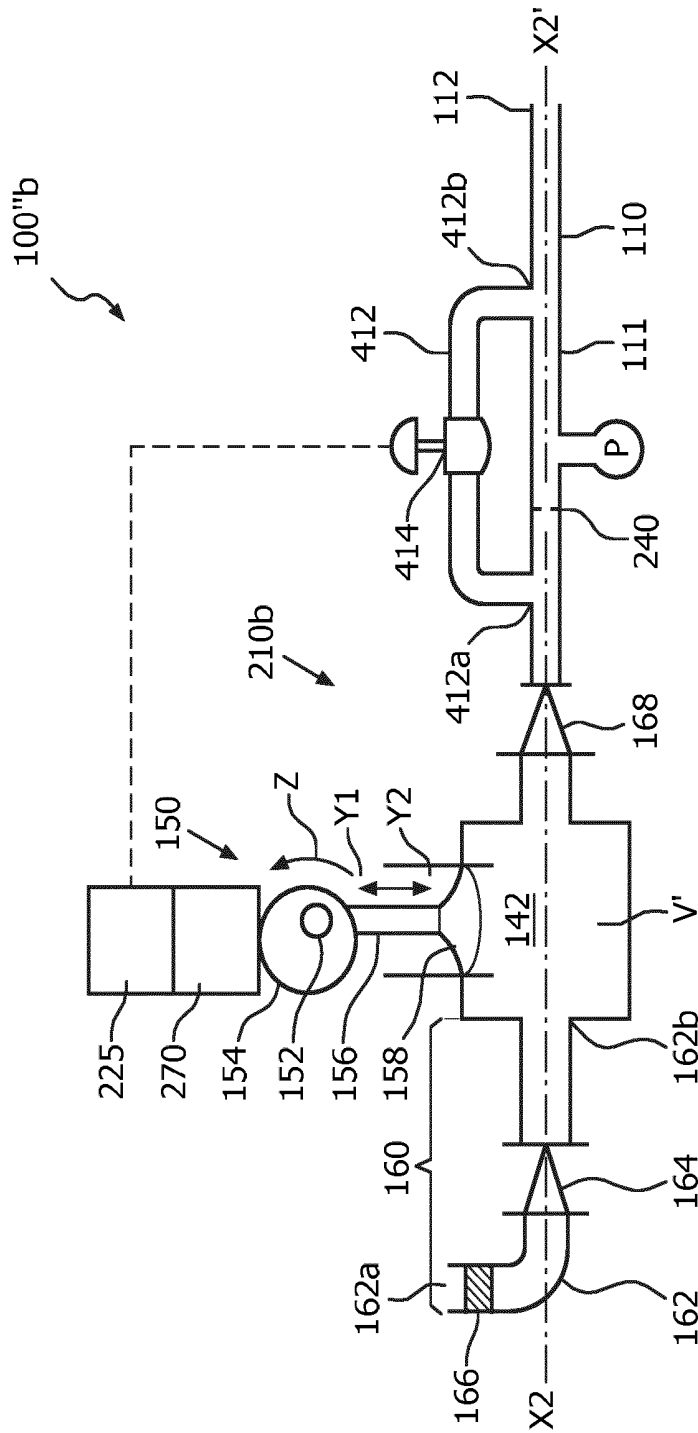

FIG. 26

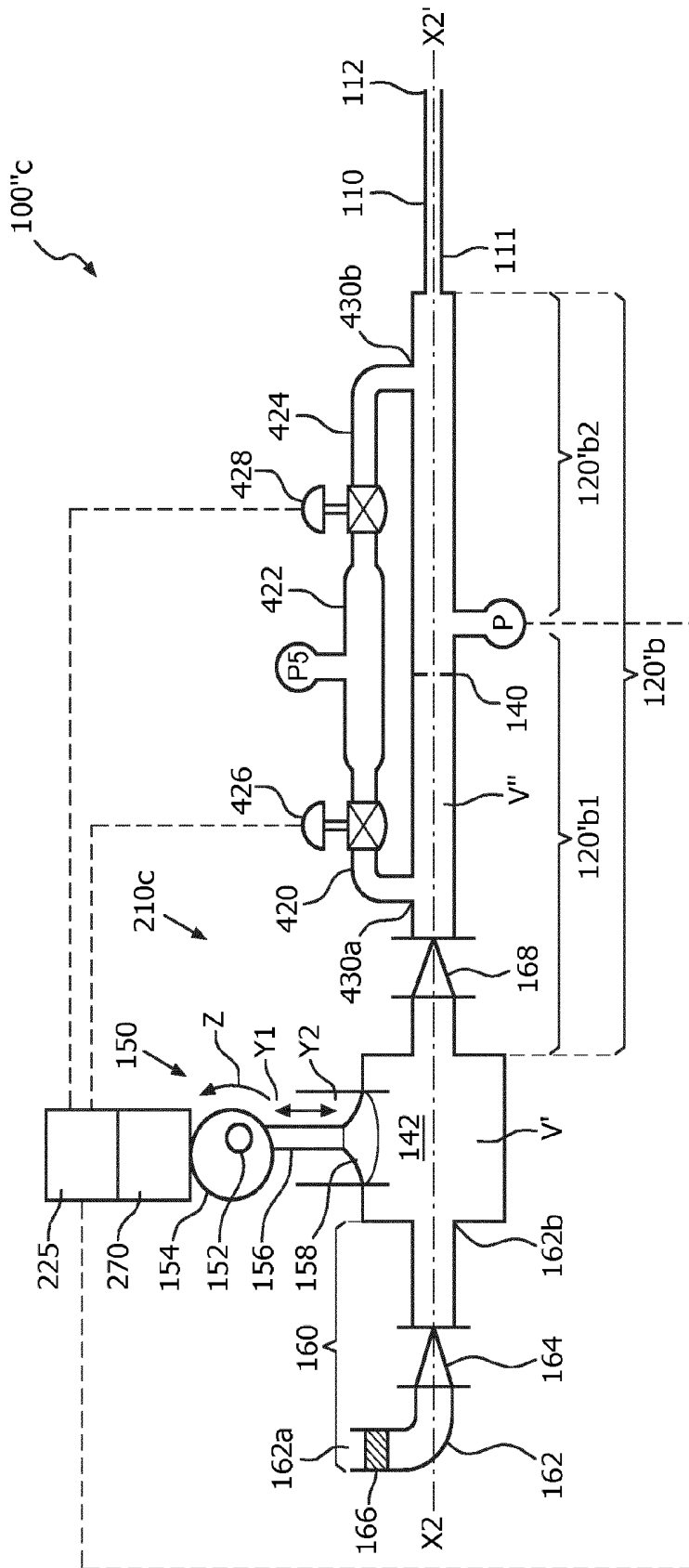

FIG. 27

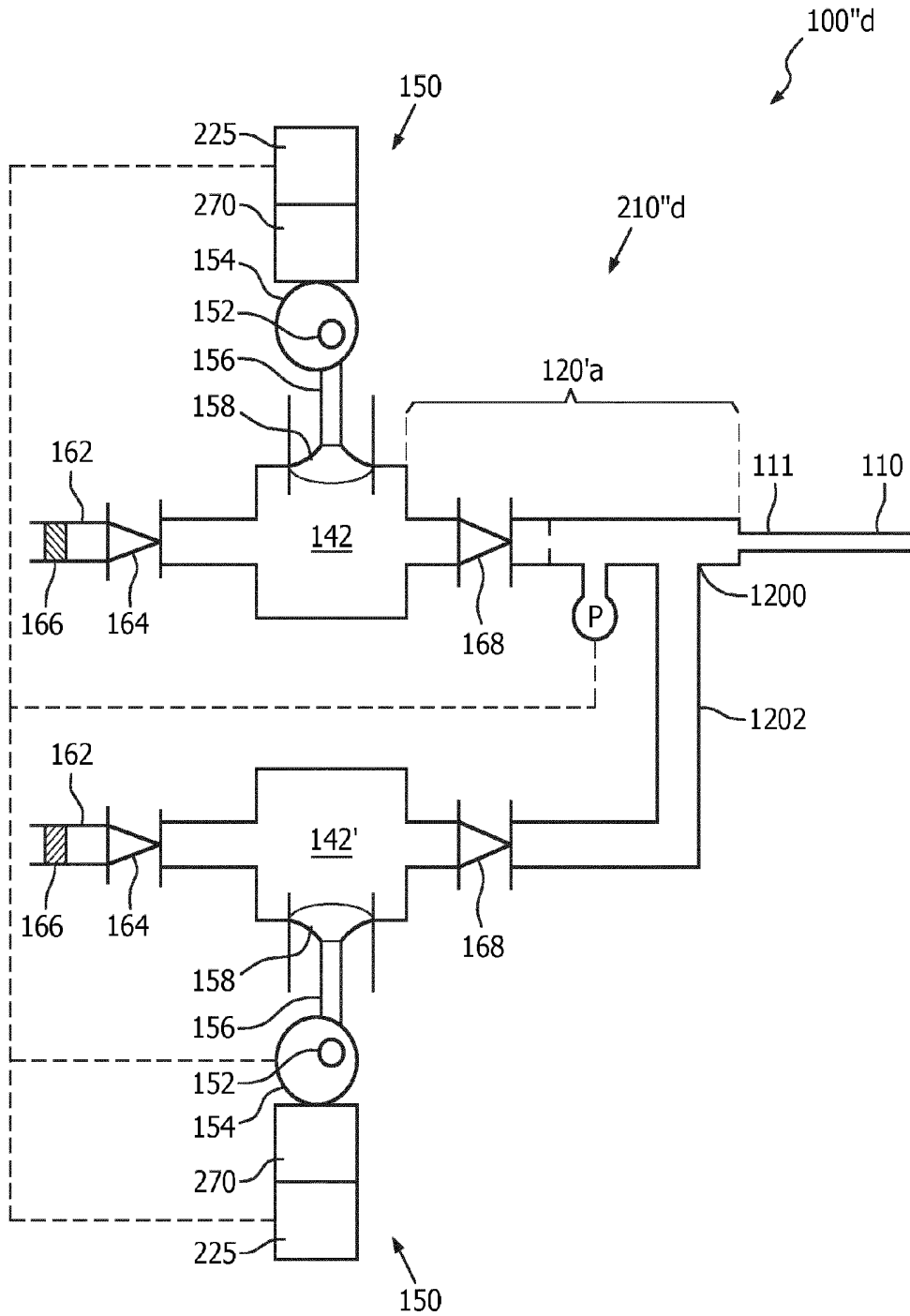

FIG. 28

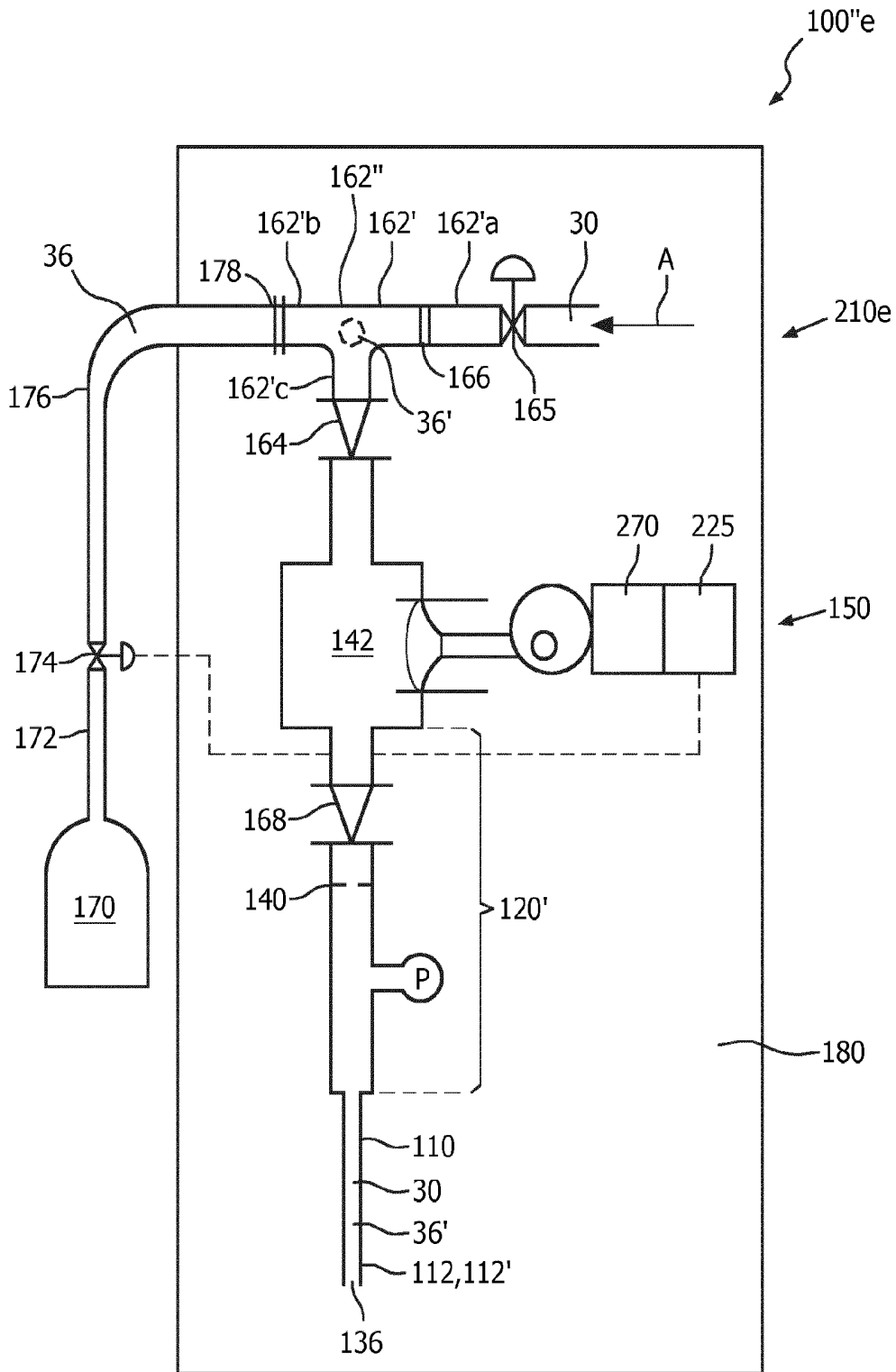

FIG. 29

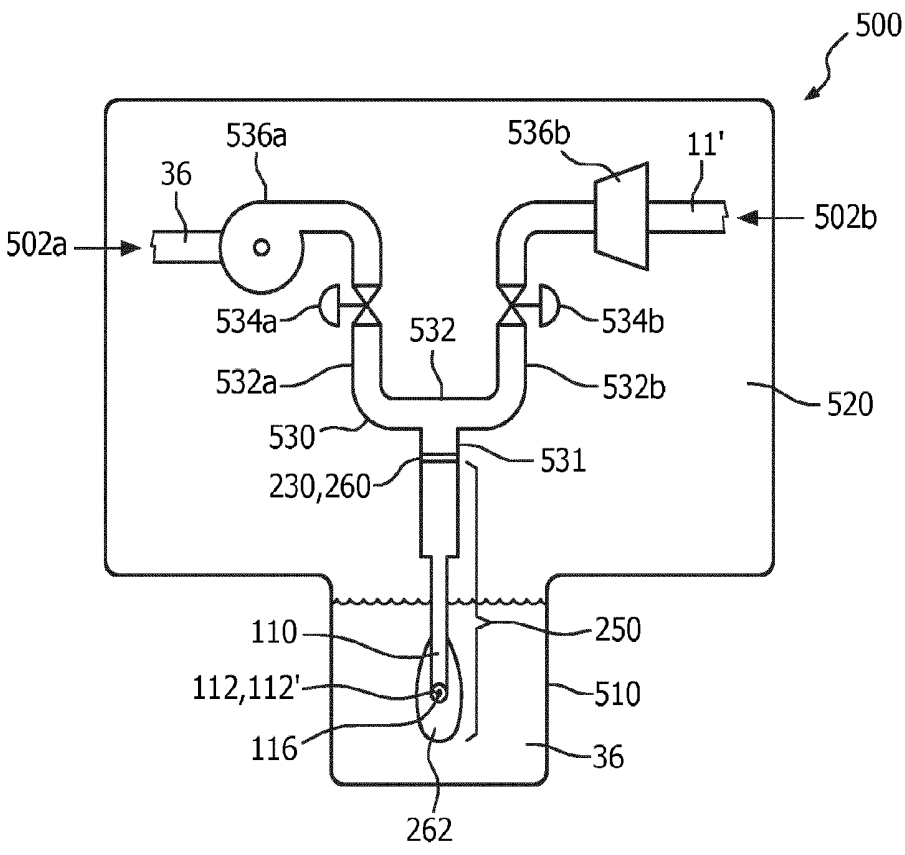
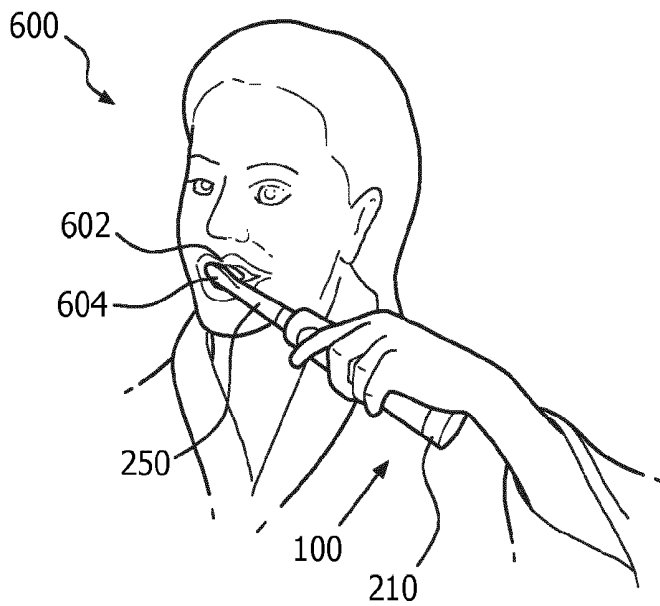
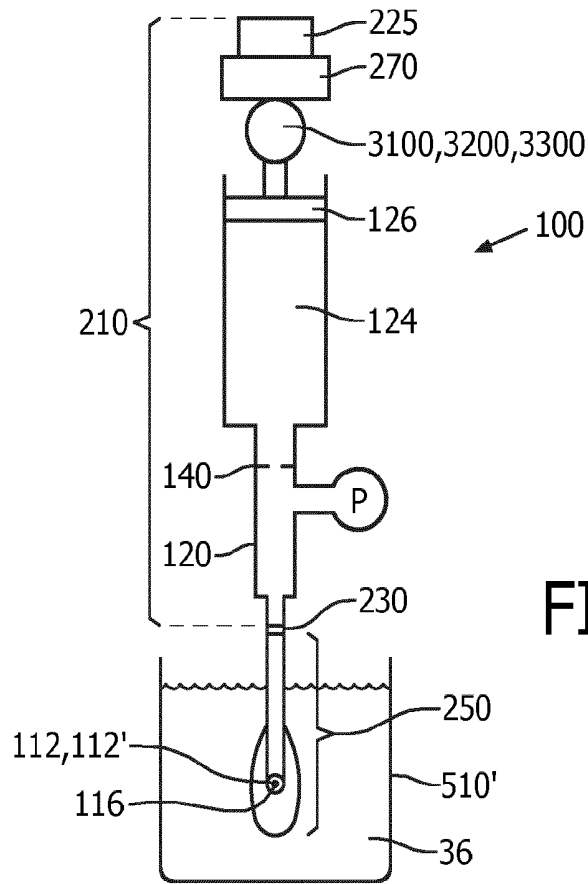

FIG. 30



REDUCING BLOCKAGES OF A PLAQUE DETECTION STREAM PROBE

TECHNICAL FIELD

[0001] The present disclosure relates to apparatuses used for detecting the state of a dental surface. More particularly, the present disclosure relates to a stream probe that is utilized to detect the state of a dental surface.

BACKGROUND OF THE INVENTION

[0002] Caries or periodontal diseases are thought to be infectious diseases caused by bacteria present in dental plaques. Removal of dental plaques is highly important for the health of oral cavities. Dental plaques, however, are not easy to identify by the naked eye. A variety of plaque detection apparatuses have been produced to aid in the detection of dental plaque and/or caries.

[0003] Most of the dental plaque detection apparatuses are configured for use by trained professionals and make use of the fact that the visible luminescence spectra from dental plaque (and/or caries) and non-decayed regions of a tooth are substantially different. Some dental plaque detection apparatuses are configured for use by consumers (most of whom are, typically, not trained dental professionals) in their own homes in helping consumers achieve good oral hygiene.

[0004] For example, one known type of dental plaque apparatus utilizes irradiated light to illuminate tooth material and gums to identify areas infected by biofilms and areas of dental plaque. This type of plaque detection apparatus may utilize a monochromatic excitation light and may be configured to detect fluorescent light in 2 bands 440-470 nm (e.g., blue light) and 560-640 nm (e.g., red light); the intensities are subtracted to reveal the dental plaque and/or caries regions.

[0005] While the aforementioned dental plaque apparatus are suitable for their intended use, they exhibit one or more shortcomings. Specifically, it is known that each area of the eye absorbs different wavelengths of light and, if too much light is absorbed by the eye, the eye may be damaged. As can be appreciated, to avoid possible eye injury, it is imperative that a user not switch on the plaque detection apparatus until the plaque detection apparatus is appropriately placed inside the mouth. The aforementioned devices, however, are not configured to automatically detect when the plaque detection apparatus are placed inside the mouth. As a result thereof, potentially harmful radiation that could damage the eyes, or cause uncomfortable glare if exposed to the eyes, may result if proper handling precautions are not followed, e.g., consumer misuse. Furthermore, this technique is especially suitable to detect old plaque; a distinction between teeth fluorescence and young (1 day old) plaque fluorescence is not made.

SUMMARY OF THE INVENTION

[0006] It is an object of the invention to provide an improved detection of a substance (e.g. plaque) on a surface (e.g. a dental surface).

[0007] Accordingly, an aspect of the present disclosure includes an apparatus for detecting the presence of a substance on a surface. The apparatus includes a proximal body portion comprising a proximal pump (e.g., syringe) portion and a proximal probe portion and at least one distal probe

portion configured to be immersed in a first fluid. The proximal pump portion and the distal probe portion are in fluid communication with one another. The distal probe portion defines a distal tip having an open port to enable the passage of a second fluid (e.g. a gas or a liquid) there-through. The apparatus is configured such that passage of the second fluid through the distal tip enables detection of a substance that may be present on the surface based on measurement of a signal correlating to a substance at least partially obstructing the passage of fluid through the open port of the distal tip.

[0008] In one aspect, the signal may be a pressure signal and the detection apparatus further includes a pressure sensor configured and disposed to detect the pressure signal. The proximal pump portion may include the pressure sensor.

[0009] In one aspect, the apparatus may further include a pressure sensing portion disposed between the proximal pump portion and the distal probe portion wherein the pressure sensor is disposed in fluid communication with the pressure sensing portion to detect the pressure signal. The proximal pump portion, the pressure sensing portion and the distal probe portion may each define internal volumes summing to a total volume of the detection apparatus such that the detection apparatus forms an acoustical low pass filter.

[0010] In another aspect, the proximal pump portion may include a movable plunger disposed therewithin and configured and disposed such that the movable plunger is reciprocally movable away from a proximal end of the proximal pump portion towards a distal end of the proximal pump portion. The movement of the plunger induces thereby a volumetric or mass flow in the distal probe portion or wherein the proximal pump portion comprises a movable diaphragm, the movement of the diaphragm inducing thereby a change in volumetric or mass flow in the distal probe portion.

[0011] The apparatus may further include a controller. The controller may process pressure readings sensed by the pressure sensor and determine whether the pressure readings are indicative of a substance obstructing the passage of fluid through the open port of the distal tip. The substance may be dental plaque.

[0012] In yet another aspect of the apparatus, the signal represents strain of the probe portion. The detection apparatus may further include a strain gauge configured and disposed on the distal probe portion to enable the strain gauge to detect and measure the signal representing strain of the probe portion.

[0013] In one aspect, the distal tip having an open port may be chamfered at an angle such that passage of the second fluid through the distal tip is enabled when the distal tip touches the surface. The angle of the chamfer of the open port may be such that passage of the second fluid through the distal tip is at least partially obstructed when the distal tip touches the surface and a substance at least partially obstructs the passage of fluid through the open port of the distal tip.

[0014] Yet another aspect of the present disclosure includes a proximal body portion that includes a pump portion, a proximal probe portion wherein the pump portion and the proximal probe portion are in fluid communication with one another, and a connector wherein the proximal probe portion can be connected via the connector to a distal probe portion of a distal probe portion of the detection apparatus to establish fluid communication between the

proximal probe portion and the distal probe portion. The detection apparatus includes a distal probe portion configured to be immersed in a first fluid. The distal probe portion defines a distal tip having an open port to enable the passage of a second fluid therethrough. The apparatus is configured such that passage of the second fluid through the distal tip enables detection of a substance that may be present on the surface based on measurement of a signal, correlating to a substance at least partially obstructing the passage of fluid through the open port of the distal tip.

[0015] Yet another aspect of the present disclosure includes a system for detecting the presence of a substance on a surface. The system includes a first detection apparatus as described above and at least a second detection apparatus configured in the manner as the first detection apparatus as described above.

[0016] Yet another aspect of the present disclosure includes a method of detecting the presence of a substance on a surface that includes, via a stream probe tubular member or stream probe defining a proximal end and an interior channel that includes a distal probe tip having an open port enabling the passage of a fluid medium therethrough, disposing the probe tip in proximity to a surface and such that the stream probe tubular member is immersed in a first fluid medium, causing a second fluid medium to flow through the interior channel and the distal probe tip and causing the distal probe tip to touch the surface in an interaction zone occurring in the first fluid medium, and probing the properties of the interaction zone via detection of at least partial obstruction of flow of the second fluid medium through the interior channel or the distal probe tip or combinations thereof.

[0017] Yet another aspect of the present disclosure includes a method of detecting the presence of a substance on a surface that includes, via at least two stream probe tubular members or stream probes each defining a proximal end and an interior channel that includes a distal probe tip having an open port enabling the passage of a fluid medium therethrough, disposing the two probe tips in proximity to a surface and such that the two stream probe tubular members or stream probes are immersed in a first fluid medium, causing a second fluid medium to flow through the interior channels and the distal probe tips and causing the distal probe tips to touch the surface in an interaction zone occurring in the first fluid medium, and probing the properties of the interaction zone via detection of at least partial obstruction of flow of the second fluid medium through the interior channels or the distal probe tips or combinations thereof.

[0018] In one aspect, the detection of at least partial obstruction of flow of the second fluid medium through the interior channels and the distal probe tips may include detection of a difference between a pressure signal detected in one of the two stream probe tubular members and another one of the two stream probe tubular members.

[0019] In another aspect, the detection of at least partial obstruction of flow of the second fluid medium through the interior channels and the distal probe tips may include detection of a difference between a strain signal detected in one of the two stream probe tubular members and another one of the two stream probe tubular members.

[0020] In yet a another aspect, the distal tip has an open port that may be chamfered at an angle such that the step of causing a second fluid medium to flow through the interior

channels and the distal probe tips is enabled when the distal tip touches the surface and the second fluid medium is enabled to flow through the chamfered open port.

[0021] In a further aspect, the step of detecting at least partial obstruction of flow of the second fluid medium through at least one of the interior channels and the distal probe tips is enabled via the angle of the chamfer of the open port being such that passage of the second fluid through the distal tip is at least partially obstructed when the distal tip touches the surface and a substance at least partially obstructs the passage of the second fluid medium through the open port of the distal tip.

[0022] In one aspect, the probing of the properties of the interaction zone may include measuring a property of dental plaque derived from the surface in the interaction zone.

[0023] In still another aspect, the causing a second fluid medium to flow through the interior channels and the distal probe tips may be performed either by causing the second fluid medium to flow distally from the proximal ends of the at least two stream probe tubular members through the distal probe tips or by causing the second fluid medium to flow proximally from the distal probe tips through the interior channels towards the proximal ends of the stream probe tubular members.

[0024] The present disclosure describes a method of probing a dental surface by recording the outflow properties of a fluid medium through a probe tip. The properties of the fluid outflowing from the probe tip can for example be measured by recording the pressure of the fluid medium as a function of time. The release properties of fluid, including bubbles, from the tip-surface region can characterize the dental surface and/or the viscoelastic properties of dental material present at the probe tip. The fluid, including bubbles, may also improve the plaque removal rate of the tooth brush.

[0025] Novel features of exemplary embodiments of the present disclosure are:

[0026] (a) a fluid medium is brought in contact with a surface at a probe tip, generating an interaction zone between the tip and the surface; and

[0027] (b) the shape and/or dynamics of the medium in the interaction zone depend on the properties of the surface and/or on materials derived from the surface; and

[0028] (c) the pressure and/or shape and/or dynamics of the medium in the interaction zone are detected.

[0029] A determination is made by a controller as to whether a level of plaque is detected at a particular dental surface of a tooth that exceeds a predetermined maximum acceptable or permissible level of plaque.

[0030] If a negative detection is made, a signal is transmitted to the user of the electric toothbrush having an integrated stream probe plaque detection system to advance the brush to an adjacent tooth or other teeth.

[0031] Alternatively, if a positive detection is made, a signal is transmitted to the user of the electric toothbrush having an integrated stream probe plaque detection system to continue brushing the particular tooth.

[0032] Accordingly, the embodiments of the present disclosure relate to an apparatus that is configured such that passage of a fluid through an open port of a distal tip enables detection of a substance that may be present on a surface, e.g., a surface of a tooth, based on measurement of a signal correlating to a substance at least partially obstructing the passage of fluid through the open port. The apparatus includes a proximal pump portion and at least one distal

probe portion configured to be immersed in another fluid. The apparatus may be included within a corresponding system that includes at least two apparatuses. A method includes probing an interaction zone for at least partial obstruction of flow.

[0033] In one exemplary embodiment, the first fluid may also pass through the open port of the distal tip of the distal probe portion, e. g., when the pressure within the distal probe portion is below ambient pressure.

[0034] In yet another exemplary embodiment, a proximal body portion of a detection apparatus for detecting the presence of a substance on a surface includes a pump portion and a proximal probe portion. The pump portion and the proximal probe portion are in fluid communication with one another. The proximal probe portion can be connected via a connector to a distal probe portion of the detection apparatus to establish fluid communication between the proximal probe portion and the distal probe portion. The detection apparatus includes the distal probe portion configured to be immersed in a first fluid. The distal probe portion defines a distal tip having an open port to enable the passage of a second fluid therethrough. The detection apparatus is configured such that the pump portion causing passage of the second fluid through the distal tip inducing thereby a change in a sensing parameter in the distal probe portion enables detection of a substance that may be present on the surface based on measurement of a signal representing the sensing parameter, correlating to a substance at least partially obstructing the passage of fluid through the open port of the distal tip. The proximal body portion also includes a parameter sensor that is configured and disposed to detect the signal representing the sensing parameter and a controller. The controller processes signal readings sensed by the parameter sensor and determining whether the signal readings are indicative of a substance obstructing the passage of fluid through the open port of the distal tip. The controller is in electrical communication with the pump portion and the parameter sensor. The controller transmits a signal that changes dynamic pressure at the distal tip upon determining that the signal readings are indicative of a substance obstructing the passage of fluid through the open port of the distal tip. In one exemplary embodiment, during usage of the detection apparatus to detect the presence of a substance on a surface, upon the controller determining that the signal readings are indicative of a substance obstructing the passage of fluid through the open port of the distal tip, the controller generates a signal causing a change in operation of the proximal body portion that causes the change in dynamic pressure and dislodging of the substance obstructing the passage of fluid through the open port of the distal tip.

[0035] In still another exemplary embodiment, when the controller processes signal readings sensed by the parameter sensor and determines that the signal readings are indicative of a substance obstructing the passage of fluid through the open port of the distal tip, the controller transmits a signal to the pump portion to change discharge pressure or flow or both pressure and flow to the distal tip to dislodge the substance obstructing the passage of fluid through the open port of the distal tip.

[0036] In one exemplary embodiment, the proximal body portion may further include the parameter sensor disposed in fluid communication with the proximal probe portion, a fluid conduit member in fluid communication with the proximal

probe portion such that the fluid conduit member forms a flow bypass around the parameter sensor, and a fluid flow interrupting device disposed in the fluid conduit member. The fluid flow interrupting device is in a closed position during operation of the pump portion. When the controller receives a signal representing the sensing parameter, correlating to a substance at least partially obstructing the passage of fluid through the open port of the distal tip, the controller transmits a signal to the fluid flow interrupting device to at least partially open to bypass the parameter sensor to change dynamic pressure at the distal tip to dislodge the substance at least partially obstructing the passage of fluid through the open port of the distal tip.

[0037] In yet another exemplary embodiment, the proximal body portion may further include a central parameter sensing portion disposed in fluid communication between the pump portion and the proximal probe portion. The central parameter sensing portion enables fluid communication between the pump portion and the proximal probe portion. The parameter sensor is disposed in fluid communication with the central parameter sensing portion. A fluid conduit member is in fluid communication with the proximal probe portion and the central parameter sensing portion such that the fluid conduit member forms a flow bypass around the parameter sensor. A fluid flow interrupting device may be disposed in the fluid conduit member and in a closed position during operation of the pump portion. When the controller receives a signal representing the sensing parameter, correlating to a substance at least partially obstructing the passage of fluid through the open port of the distal tip, the controller transmits a signal to the fluid flow interrupting device to at least partially open to bypass the parameter sensor to change dynamic pressure at the distal tip to dislodge the substance at least partially obstructing the passage of fluid through the open port of the distal tip.

[0038] In a further exemplary embodiment, the fluid conduit member further may include a fluid reservoir disposed upstream of the fluid flow interrupting device and in fluid communication with the central parameter sensing portion wherein the fluid reservoir is pressurized at a pressure above the pressure in the central parameter sensing portion downstream of the parameter sensor when the fluid flow interrupting device is in a closed position.

[0039] In yet another exemplary embodiment, when the controller receives a signal representing the sensing parameter, correlating to a substance at least partially obstructing the passage of fluid through the open port of the distal tip, the controller transmits a signal to the fluid flow interrupting device to at least partially open to release pressure from the fluid reservoir to bypass the parameter sensor thereby increasing dynamic pressure at the distal tip to dislodge the substance at least partially obstructing the passage of fluid through the open port of the distal tip.

[0040] In a further exemplary embodiment, a second fluid flow interrupting device is disposed upstream of the fluid reservoir such that fluid communication is provided between a portion of the central parameter sensing portion that is upstream of the parameter sensor and a portion of the central parameter sensing portion that is downstream of the parameter sensor wherein the second fluid flow interrupting device, the fluid reservoir and the fluid flow interrupting device form a flow by-pass around the parameter sensor.

[0041] In a still further exemplary embodiment, during usage of the detection apparatus, after the controller has

transmitted a signal to the fluid flow interrupting device to at least partially open, when pressure in the fluid reservoir has decreased, the controller transmits a signal to the second fluid flow interrupting device to transfer from a closed position to an at least partially open position to bypass flow around the parameter sensor, thereby increasing dynamic pressure at the distal tip to dislodge the substance at least partially obstructing the passage of fluid through the open port of the distal tip.

[0042] In one exemplary embodiment, the proximal body portion may further include a central parameter sensing portion disposed in fluid communication between the pump portion and the proximal probe portion. The central parameter sensing portion enables fluid communication between the pump portion and the proximal probe portion. A parameter sensor is disposed in fluid communication with the central parameter sensing portion. A stand-by pump portion has a pump discharge fluid conduit member in fluid communication with the central parameter sensing portion through a connection in the central parameter sensing portion downstream of the parameter sensor. When the controller receives a signal representing the sensing parameter, correlating to a substance at least partially obstructing the passage of fluid through the open port of the distal tip, the controller transmits a signal to the stand-by pump portion to initiate operation thereby increasing dynamic pressure at the distal tip to dislodge the substance at least partially obstructing the passage of fluid through the open port of the distal tip.

[0043] In one exemplary embodiment, during non-usage of the detection apparatus to detect the presence of a substance on a surface, the controller generates a signal causing a change in operation of the proximal body portion that changes dynamic pressure and causes dislodging of the substance obstructing the passage of fluid through the open port of the distal tip. The change in operation of the proximal body portion may be achieved by the pump portion pumping a fluid through the distal probe portion for a period of time necessary to minimize the probability of occurrence of a future blockage of the distal tip or for a period of time necessary to dislodge a substance obstructing the passage of fluid through the open port of the distal tip.

[0044] In yet another exemplary embodiment, the period of time necessary to minimize the probability of occurrence of a future blockage of the distal tip is for a period of time before usage of the detection apparatus to detect the presence of a substance on a surface or is for a period of time after usage of the detection apparatus to detect the presence of a substance on a surface.

[0045] In a further exemplary embodiment, the period of time necessary to dislodge a substance obstructing the passage of fluid through the open port of the distal tip is for a period of time before usage of the detection apparatus to detect the presence of a substance on a surface or is for a period of time after usage of the detection apparatus to detect the presence of a substance on a surface.

[0046] In yet another exemplary embodiment, the proximal body portion further includes a vibrating shaft for vibrating bristles disposed on a distal oral insertion portion of the detection apparatus. The vibrating bristles effect dental hygiene of a subject or of a user of the detection apparatus. The proximal body portion may further include a bristle vibration motor for operating the vibrating shaft and an activation device for activating the bristle vibration motor

to operate the vibrating shaft. The activation device is in electrical communication with the controller. The controller transmits a signal to the pump portion to cause passage of the second fluid through the distal tip before activation of the activation device. The change in dynamic pressure is in comparison to the dynamic pressure before activation of the activation device. Alternatively or additionally, the controller transmits a signal to the pump portion to cause passage of the second fluid through the distal tip after activation of the activation device and wherein the controller transmits a signal to the pump portion to continue to cause passage of the second fluid through the distal tip after de-activation of the activation device. The change in dynamic pressure is in comparison to the dynamic pressure after de-activation of the activation device.

[0047] In one exemplary embodiment, the proximal body portion may further include a detection apparatus usage sensor in electrical communication with the controller and the time before activation of the activation device is sensed by the controller as being initiated by activation of the detection apparatus usage sensor.

[0048] In a further exemplary embodiment, the detection apparatus usage sensor is a motion sensor or a contact sensor or combinations thereof. The contactor sensor includes a pressure sensor or a temperature sensor or combinations thereof.

[0049] In one embodiment, when the controller senses activation of the detection apparatus usage sensor without activation of the activation device in a prescribed time period following receipt of a signal from the detection apparatus usage sensor indicating usage of the detection apparatus, the controller signals to the pump portion to cease causing passage of the second fluid through the distal tip.

[0050] In still another exemplary embodiment, the pump portion may include a suction intake enabling suction of the second fluid through the pump portion and enabling suction of a third fluid through the pump portion wherein the change in dynamic pressure includes the pump portion causing passage of the third fluid to the distal tip to dislodge a substance obstructing the passage of fluid through the open port of the distal tip. The third fluid may be a liquid.

[0051] In a further exemplary embodiment, the third fluid may be a liquid droplet and the pump portion suctions through the suction intake concurrently the second fluid and the liquid droplet causing passage of the second fluid and the liquid droplet to the distal tip. The pump portion may impart sufficient kinetic energy to the liquid droplet such that passage of the liquid droplet to the distal tip changes dynamic pressure at the distal tip and causes dislodging of a substance obstructing the passage of the second fluid through the open port of the distal tip.

[0052] In a further exemplary embodiment of the proximal body portion, the controller may control operation of the pump portion such that at least one alternating cycle of operation of the pump portion causes a negative pressure condition and a positive pressure condition at the distal tip, thereby oscillating fluid flow through the distal tip. The alternating cycle of operation from or to a negative pressure condition to or from a positive pressure condition changes the dynamic pressure at the distal tip.

[0053] These and other aspects of the present disclosure will be apparent from and elucidated with reference to the embodiment(s) described hereinafter.

BRIEF DESCRIPTION OF THE DRAWINGS

[0054] The aspects of the present disclosure may be better understood with reference to the following figures. The components in the figures are not necessarily to scale, emphasis instead being placed upon clearly illustrating the principles of the disclosure. Moreover, in the figures, like reference numerals designate corresponding parts throughout the several views.

[0055] In the figures:

[0056] FIG. 1 illustrates the general principle of a stream probe impacting a dental surface in accordance with the present disclosure;

[0057] FIG. 2 illustrates the effect of surface tension on a less hydrophilic surface and on a more hydrophilic surface for a stream probe impacting a dental surface in accordance with one exemplary embodiment of the present disclosure;

[0058] FIG. 3 illustrates left and right photographs of air bubbles from a needle in water touching a plaque surface on the left and an enamel surface on the right in accordance with one exemplary embodiment of the present disclosure;

[0059] FIG. 4A illustrates one exemplary embodiment of the present disclosure of a stream probe having a pump portion supplying a continuous stream of gas via a tube to a probe tip while measuring the internal tube pressure;

[0060] FIG. 4B illustrates another exemplary embodiment of the stream probe of FIG. 4A having one exemplary embodiment of a pump portion supplying a continuous stream of gas via a tube to a probe tip while measuring the internal pump pressure;

[0061] FIG. 4C illustrates another exemplary embodiment of the stream probe of FIGS. 4A and 4B having another exemplary embodiment of a pump portion supplying a generally continuous stream of gas via a tube to a probe tip while measuring the internal pump pressure;

[0062] FIG. 5 illustrates a sample pressure measurement of the stream probe of FIG. 4A as a function of time;

[0063] FIG. 6 illustrates a sample pressure signal amplitude as a function of distance of the probe tip of FIG. 4A to various dental surfaces;

[0064] FIG. 7 illustrates a system for detecting the presence of a substance on a surface according to one exemplary embodiment of the present disclosure wherein on the left is illustrated one embodiment of a stream probe having a partial blockage from dental surface material such as dental plaque while on the right is illustrated one embodiment of an unblocked stream probe;

[0065] FIG. 8 illustrates on the left a sample pressure measurement versus time for the unblocked stream probe of FIG. 7 and on the right illustrates a sample pressure measurement versus time for the partially blocked stream probe of FIG. 7;

[0066] FIG. 9 illustrates a pressure signal versus time for a stream probe having a Teflon tip in accordance with one exemplary embodiment of the present disclosure;

[0067] FIG. 10 illustrates a stream probe system incorporated into a dental apparatus such as an electric toothbrush in accordance with one exemplary embodiment of the present disclosure;

[0068] FIG. 11 illustrates a view of the brush of the dental apparatus taken along line 211-211 of FIG. 10 having a stream probe tip at a position within the bristles of the brush;

[0069] FIG. 12 illustrates an alternate exemplary embodiment of the view of the brush of FIG. 11 wherein the stream probe tip extends distally from the bristles of the brush;

[0070] FIG. 13 illustrates an alternate exemplary embodiment of the stream probe of FIG. 4A having a pump portion supplying a continuous stream of gas via a tube to two probe tips while measuring the internal tube pressure at the inlet to a first stream probe tip and the internal pressure at the inlet to a second stream probe tip;

[0071] FIG. 14 illustrates an alternate exemplary embodiment of the brush of FIG. 10 that includes multiple stream probes on the brush that includes the base of the brush such as according to the embodiment of a stream probe according to FIG. 13;

[0072] FIG. 15 illustrates another view of the brush of FIG. 14;

[0073] FIG. 16 illustrates still another view of the brush of FIG. 14;

[0074] FIG. 17 illustrates another alternate exemplary embodiment of the brush of FIG. 10 that includes multiple stream probes on the brush that includes the base of the brush;

[0075] FIG. 18 illustrates another view of the brush of FIG. 17;

[0076] FIG. 19 illustrates still another view of the brush of FIG. 17;

[0077] FIG. 20 illustrates one exemplary embodiment of the present disclosure of a system for detecting the presence of a substance on a surface wherein a stream probe operating apparatus includes a first stream probe;

[0078] FIG. 21 illustrates the system of FIG. 20 wherein another stream probe operating apparatus includes a second stream probe;

[0079] FIG. 22 illustrates the system of FIGS. 20 and 21 wherein a motor is operably connected to a common shaft that operates the stream probe operating apparatuses of FIGS. 20 and 21;

[0080] FIG. 23 illustrates a representation of an actual photograph of a distal tip of a distal probe portion that is a Teflon tube with an open port 136 such as illustrated in FIGS. 4A, 4B and 4C and FIG. 10;

[0081] FIG. 24 illustrates the open port of FIG. 23 wherein the open port has been blocked after some experiments with toothpaste that contains relatively large blue particles;

[0082] FIG. 25 illustrates an exemplary embodiment of a detection apparatus for detecting the presence of a substance on a surface according to the present disclosure that includes a proximal body portion having a fluid conduit member that forms a flow bypass around a parameter sensor;

[0083] FIG. 26 illustrates another exemplary embodiment of a detection apparatus for detecting the presence of a substance on a surface according to the present disclosure that includes a proximal body portion having a fluid conduit member that forms a flow bypass around a parameter sensor;

[0084] FIG. 27 illustrates another exemplary embodiment of a stream probe or detection apparatus for detecting the presence of a substance on a surface that includes a proximal body portion having a fluid reservoir that bypasses a parameter sensor;

[0085] FIG. 28 illustrates yet another exemplary embodiment of a stream probe or detection apparatus for detecting the presence of a substance on a surface that includes a proximal body portion that includes a first pump portion and a second or stand-by pump portion that forms a bypass around a parameter sensor;

[0086] FIG. 29 illustrates still another exemplary embodiment of a stream probe or detection apparatus for detecting

the presence of a substance on a surface that includes a proximal body portion a suction intake to the pump portion enables suction of a fluid through the pump portion and enables suction of another fluid through the pump portion; [0087] FIG. 30 illustrates yet another exemplary embodiment of a stream probe or detection apparatus for detecting the presence of a substance on a surface wherein the distal oral insertion portion is detached from the proximal body portion and positioned in a detection apparatus sanitizing unit;

[0088] FIG. 31 illustrates one exemplary embodiment of yet another method of dislodging a substance 116 obstructing the passage of fluid through the open port of the distal tip wherein the distal oral insertion portion is immersed in a liquid reservoir; and

[0089] FIG. 32 illustrates a user of the stream probe of FIG. 31 wherein the distal oral insertion portion is inserted into the mouth of the user and immersed in a liquid that is in the mouth of the user.

DETAILED DESCRIPTION OF EMBODIMENTS

[0090] The present disclosure describes various embodiments of systems, devices, and methods related to assisting users to clean their teeth, in particular by informing users if they are indeed removing plaque from their teeth and if they have fully removed the plaque, providing both reassurance and coaching them into good habits. In one exemplary embodiment, the information is provided in real time during brushing, as otherwise consumer acceptance is likely to be low. For example, it is useful if a toothbrush gives the user a signal when the position at which they are brushing is clean, so they can move to the next tooth. This may reduce their brushing time, but will also lead to a better, more conscious brushing routine.

[0091] A particular goal of utilization of the exemplary embodiments of the present disclosure is to be able to detect plaque within a vibrating brush system surrounded with toothpaste foam, e.g., a Philips Sonicare toothbrush. The detection system should provide contrast between a surface with the thicker, removable plaque layers, and a more clean pellicle/calculus/thin plaque/tooth surface.

[0092] As defined herein, the term “is coupled to” may also be interpreted as “is configured to be coupled to”. The term “to transmit” may also be interpreted as “to enable transmission of”. The term “to receive” may also be interpreted as “to enable reception of”.

[0093] FIG. 1 illustrates a method of detecting the presence of a substance on a surface, e.g., a substance such as dental plaque on a surface such as tooth enamel, using a stream probe 10 according to one exemplary embodiment of the present disclosure. The stream probe 10, exemplarily illustrated as a cylindrical tube member, defines a proximal end 16, an interior channel 15 and a distal probe tip 12. The interior channel 15 contains a fluid medium 14, e.g., a gas or a liquid. The probe tip 12 is placed in the proximity of a surface 13, e.g., a dental surface. The probe 10 is immersed in a fluid medium 11, e.g., an aqueous solution such as a dental cleaning solution. Probe fluid medium 14 flows through the probe channel 15 and touches surface 13 in interaction zone 17. The properties of the interaction zone 17 are probed via the outflow of probe medium 14.

[0094] As described in more detail below with respect to FIG. 10, an apparatus or instrument for detecting the presence of a substance on a surface, such as a dental cleaning

instrument including an electric toothbrush having an integrated stream probe plaque detection system, is configured such that fluid medium 14 is brought in contact with surface 13, e.g. a dental surface, at probe tip 12, generating interaction zone 17 between distal tip 12 and surface 13.

[0095] The shape and/or dynamics of the medium 14 in the interaction zone 17 depend on the properties of the surface 13 and/or on materials derived from the surface 13, the pressure and/or shape and/or dynamics of the medium 14 in the interaction zone 17 are detected and a determination is made by a controller as to whether a predetermined maximum acceptable level of plaque is detected at the particular dental surface 13, as described in more detail below with respect to FIG. 10.

[0096] More particularly, when medium 14 is a gas 30 (see FIG. 2), then a gas meniscus will appear at the tip 12 and will become in contact with surface 13. The shape and dynamics of the gas at the tip will depend on the properties of the probe tip 12 (e.g. tip material, surface energy, shape, diameter, roughness), properties of solution 11 (e.g. materials composition), properties of medium 14 (e.g. pressure, flow speed), and properties of surface 13 (e.g. viscoelastic properties, surface tension) and/or on materials derived from the surface 13 (viscoelastic properties, adherence to surface, texture etc.).

[0097] FIG. 2 illustrates the influence of surface tension. In the case of a surface with a high surface energy or a strongly hydrated surface, e.g. a hydrophilic surface 31 such as the surface of plaque as illustrated in the left photograph, the gas 30 will not easily displace the aqueous medium 11 from the surface 31 near the interaction zone 17.

[0098] In the case of a surface with a low surface energy or a less hydrated surface, e.g. a less hydrophilic surface 33 such as the enamel surface of a tooth as illustrated in the right photograph, the gas 30 more easily displaces the aqueous medium 11 from the surface 33. The properties (shape, pressure, release rate, etc) of bubbles 32 and 34 depend on the surface tension of the dental surface 31 or 33. This is referred to as the bubble method. That is, the stream probe or distal probe portion 10 is configured such that passage of the second fluid such as the gas 30 through the distal tip 12 enables detection of a substance that may be present on the surface 31 or 33 based on measurement of a signal correlating to, in proximity to the surface 31 or 33, one or more bubbles 32 or 34 generated by the second fluid such as the gas 30 in the first fluid such as the aqueous medium 11.

[0099] FIG. 3 illustrates photographs of such types of air bubbles 32 and 34 from stream probe 10 under aqueous solution 11, e.g., water. As illustrated in the left photograph, an air bubble 32 does not stick on a wet plaque layer 31, while, as illustrated in the right photograph, air bubble 34 does stick on enamel surface 33, showing that the plaque layer 31 is more hydrophilic as compared to enamel surface 33.

[0100] FIGS. 4A, 4B and 4C each illustrate a detection apparatus or instrument for detecting the presence of a substance on a surface according to exemplary embodiments of the present disclosure, wherein the detection apparatus is exemplified by a stream probe that includes a parameter sensor to demonstrate the principle of plaque detection by parameter sensing and measurement. As defined herein, a parameter sensor includes a pressure sensor or a strain sensor or a flow sensor, or combinations thereof, which

sense a physical measurement represented by a signal that is indicative of blockage of flow in the stream probe which may, in turn, be indicative of plaque or other substance blocking flow in the stream probe. A flow sensor which measures differential pressure or flow of heat from a wire which has been heated above ambient temperature are flow sensors or other means known or to be conceived for pressure, strain or flow or other measurement, including chemical or biological measurements, are included within the definition of a parameter sensor which sense a physical measurement represented by a signal that is indicative of blockage of flow in the stream probe which may be indicative of plaque or other substance blocking flow in the stream probe. For simplicity, for the purposes of description, the parameter sensor or sensors are exemplified by one or more pressure sensors. Although the locations for the parameter sensors illustrated in the figures are intended to apply generically to each different type of parameter, those skilled in the art will recognize that the location of the parameter sensor may be adjusted, if necessary, from the location or locations shown in the drawings, depending on the specific type of parameter sensor or sensors being employed. The embodiments are not limited in this context.

[0101] More particularly, in FIG. 4A, a stream probe 100 includes a proximal pump portion 124 such as a tubular syringe portion as shown, a central parameter sensing portion 120, exemplarily having a tubular configuration as shown, and a distal probe portion 110, also exemplarily having a tubular configuration as shown, defining a distal probe tip 112. The distal tubular probe portion 110 defines a first length L1 and a first cross-sectional area A1, the central parameter sensing tubular portion 120 defines a second length L2 and a second cross-sectional area A2, while the proximal tubular syringe portion 124 defines a third length L3 and a third cross-sectional area A3. The proximal tubular syringe portion 124 includes, e.g., in the exemplary embodiment of FIG. 4A, a reciprocally movable plunger 126 initially disposed in the vicinity of proximal end 124'.

[0102] A continuous fluid stream 130 of air is supplied by the plunger 126 through the central parameter sensing portion tubular portion 120 to the probe tip 112 when the plunger moves longitudinally along the length L3 at a constant velocity and away from the proximal end 124'. When the fluid stream 130 is a gas, a continuous stream 130 of gas is supplied through the plunger 126 (such as via an aperture 128 in the plunger 126 (see plunger 126' in FIG. 4B) or from a branch connection 122 connecting to the central parameter sensing tubular portion 120 to the probe tip 112. In one exemplary embodiment, at a location upstream from the branch connection 122, a restriction orifice 140 may be disposed in the central parameter sensing tubular portion 120.

[0103] As the plunger 126 moves along the length L3 towards distal end 124" of the proximal tubular syringe portion 124, the pressure inside the central parameter sensing tubular portion 120 is measured (downstream of restriction orifice 140 when the restriction orifice 140 is present) using pressure meter P that is in fluid communication with the central parameter sensing tubular portion 120 and the distal tubular probe portion 110 via the branch connection 122.

[0104] When the plunger 126 moves the pressure at pressure meter P versus time characterizes the interaction of the gas meniscus at the tip 112 of the probe 110 with the surface

(see FIG. 1, surface 13, and FIGS. 2 and 3, surfaces 31 and 33). The presence of the restriction orifice 140 improves the response time of the pressure meter P since only the volume of the stream probe 100 downstream of the restriction orifice 140 is relevant and the stream probe 100 behaves more closely or approximately as a flow source rather than a pressure source. The volume upstream of the restriction orifice 140 becomes less relevant.

[0105] For the bubble method, the pressure difference is generally constant, which means that the bubble size varies and so the bubble rate varies with constant plunger velocity, because the volume in the system changes. A reciprocally movable plunger may be used to obtain a generally fixed bubble rate. As described above, in one exemplary embodiment, the pressure sensor P may function either alternatively or additionally as a flow sensor, e.g., as a differential pressure sensor. Those skilled in the art will recognize that flow of the fluid stream or second fluid 130 through the distal probe tip 112 may be detected by means other than pressure sensors such as pressure sensor P, e.g., acoustically or thermally. The embodiments are not limited in this context. Consequently, the movement of the plunger 126 induces a change in pressure or volumetric or mass flow through the distal probe tip 112.

[0106] FIG. 5 illustrates an example of a pressure signal (measured in Newtons/sq. meter, N/m^2) as a function of time (1 division corresponds with a second) utilizing the stream probe 100 of FIG. 4A. The regular variation of the signal is caused by the regular release of gas bubbles at the probe tip 112.

[0107] The sensitivity of the pressure readings can be increased by carefully choosing the dimensions of the components. The total volume V1 (equal to $A1 \times L1$) plus volume V2 (equal to $A2 \times L2$) plus volume V3 (equal to $A3 \times L3$) from both the tube 120 and the syringe 124 together with the probe 110, form an acoustical low-pass filter. In the exemplary stream probe 100 of FIG. 4A, the cross-sectional area A3 is greater than the cross-sectional area A2 which in turn is greater than the cross-sectional area A1. The gas flow resistance in the system should be designed small enough to have a good system response time. When bubble-induced pressure differences are recorded, then the ratio between bubble volume and total system volume should be large enough to have a sufficient pressure difference signal due to air bubble release at the probe tip 112. Also the thermoviscous losses of the pressure wave interacting with the walls of tube 120 as well as the probe 110 must be taken into account, as they can lead to a loss of signal.

[0108] In the stream probe 100 illustrated in FIG. 4A, the three volumes differ from one another as an example. However, the three volumes could be equal to one another or the pump volume could be less than the probe volume.

[0109] FIG. 4B illustrates an alternate exemplary embodiment of a stream probe according to the present disclosure. More particularly, in stream probe 100', the central parameter sensing portion 120 of stream probe 100 in FIG. 4A is omitted and stream probe 100' includes only proximal pump portion 124 and distal probe portion 110. A pressure sensor P1 is now exemplarily positioned at plunger 126' to sense pressure in the proximal pump portion 124 via an aperture 128 in the plunger 126'.

[0110] Alternatively, a pressure sensor P2 may be positioned in the distal probe portion 110 at a mechanical connection 230. In a similar manner as described above with

respect to FIG. 4A and restriction orifice 140, in one exemplary embodiment, a restriction orifice 240 may be disposed in the distal probe portion 110 upstream of the mechanical connection 230 and thus upstream of pressure sensor P2. Again, the presence of the restriction orifice 240 improves the response time of the pressure meter P2 since only the volume of the stream probe 100' downstream of the restriction orifice 240 is relevant and the stream probe 100' behaves more closely or approximately as a flow source rather than a pressure source. The volume upstream of the restriction orifice 240 becomes less relevant.

[0111] However, it should be noted that for the case of pressure sensor P1, the restriction orifice 240 is optional and is not required for proper sensing of the pressure in distal probe portion 110.

[0112] In one exemplary embodiment, the pressure sensor P2 may function either alternatively or additionally as a flow sensor, e.g., as a differential pressure sensor. Those skilled in the art will recognize that flow of the second fluid through the distal probe tip 112 may be detected by means other than pressure sensors such as pressure sensor P2, e.g., acoustically or thermally. The embodiments are not limited in this context. Consequently, the movement of the plunger 126 induces a change in pressure or volumetric or mass flow through the distal probe tip 112.

[0113] In a similar manner as described with respect to stream probe 100 in FIG. 4A, volume V3 of the proximal pump portion 124 may be greater than volume V1 of the distal probe portion 110 in stream probe 100' in FIG. 4B, as illustrated. Alternatively, the two volumes may be equal to one another or volume V3 may be less than volume V1.

[0114] It should be noted that when restriction orifice 140 is present in stream probe 100 illustrated in FIG. 4A, the volume V3 and the portion of the volume V2 upstream of the restriction orifice 140 become less relevant to the pressure response as compared to the volume in the portion of volume V2 downstream of the restriction orifice 140 and the volume V1.

[0115] Similarly, when restriction orifice 240 is present in stream probe 100' illustrated in FIG. 4B, the volume V3 and the volume V1 upstream of restriction orifice 240 become less relevant to the pressure response as compared to the volume V1 downstream of the restriction orifice 240.

[0116] Additionally, those skilled in the art will recognize that the restriction of flow via orifices 140 and 240 may be effected by crimping central parameter sensing tubular portion 120 or distal probe portion 110 in lieu of installing a restriction orifice. As defined herein, a restriction orifice includes a crimped section of tubing.

[0117] Alternatively, a parameter sensor represented by strain gauge 132 may be disposed on the external surface of the distal probe 110. The strain gauge 132 may also be disposed on the external surface of the proximal pump portion 124 (not shown). The strain readings sensed by strain gauge 132 may be read directly or converted to pressure readings as a function of time to yield a readout similar to FIG. 5 as an alternative method to determine the release of gas bubbles at the probe tip 112.

[0118] FIG. 4C illustrates another exemplary embodiment of the stream probe more particularly of FIG. 4A and of FIG. 4B having another exemplary embodiment of a pump portion supplying a generally continuous stream of gas via a tube to a probe tip while sensing a parameter indicative of blockage of flow in the stream probe, which may, in turn, be

indicative of plaque or other substance blocking flow in the stream probe. More particularly, stream probe 100" exemplifies a fluid pump designed to provide a generally continuous flow, which is generally advantageous in operation. Stream probe 100" is generally similar to stream probe 100 of FIG. 4A and includes distal probe portion 110 and distal probe tip 112 and central parameter sensing portion 120' which also includes parameter sensor P represented by a pressure sensor and also may include restriction orifice 140 upstream of the pressure sensor P.

[0119] Stream probe 100" differs from stream probe 100 in that proximal pump portion 124 is replaced by proximal pump portion 142 wherein, in place of reciprocating plunger 126, that reciprocates along center line axis X1-X1' of the proximal pump portion 124, diaphragm pump 150 reciprocates in a direction transverse to longitudinal axis X2-X2' of proximal pump portion 124, the direction of reciprocation of diaphragm pump 150 indicated by double arrow Y1-Y2. The diaphragm pump 150 includes a motor 152 (represented by a shaft) and an eccentric mechanism 154 which is operatively connected to a connecting rod or shaft 156 that in turn is operatively connected to a flexible or compressible diaphragm 158.

[0120] An air intake supply path 160 is in fluid communication with proximal pump portion 142 to supply air from the ambient surroundings to the proximal pump portion 142. The air intake supply path 160 includes an intake conduit member 162 having a suction intake port 162a from the ambient air and a downstream connection 162b to the proximal pump portion 142, thereby providing fluid communication between the proximal pump portion 142 and the ambient air via the suction port 162a. A suction flow interruption device 164, e.g. a check valve, is disposed in the intake conduit member 162 between the suction port 162a and the downstream connection 162b. A suction intake filter 166, e.g. a membrane made from a porous material such as expanded polytetrafluoroethylene ePTFE (sold under the trade name Gore-Tex® by W. L. Gore & Associates, Inc., Elkton, Md., USA) may be disposed in the air intake supply path 160 in the intake conduit member 162 upstream of the suction flow interruption device 164 and generally in proximity of the suction intake port 162a to facilitate periodic replacement.

[0121] The central parameter sensing portion 120' serves also as a discharge flow path for the proximal pump portion 142. A proximal pump portion discharge flow path flow interruption device 168, e.g., a check valve, is disposed in the central parameter sensing portion 120' upstream of the parameter sensor P and, when present, the restriction orifice 140.

[0122] Thus the distal tip 112 is in fluid communication with the suction intake port 162a of the air intake conduit member 162 of the air intake supply path 160 via the distal probe portion 110, the central parameter sensing portion 120' and the proximal pump portion 142.

[0123] During operation of the motor 152, the motor 152 rotates, in the direction indicated by arrow Z, the eccentric mechanism 154, thereby imparting a reciprocating motion to the connecting rod or shaft 156. When the connecting rod or shaft 156 moves in the direction of arrow Y1 towards the motor 152, the flexible or compressible diaphragm 158 moves also in the direction of arrow Y1 towards the motor 152, thereby causing a reduction in pressure within the interior volume V' of the proximal pump portion 142. The

reduction in pressure causes pump portion discharge flow path flow interruption device **168** to close and causes the suction flow interruption device **164** to open, thereby drawing air through the suction intake port **162a**.

[0124] The eccentric mechanism **154** continues to rotate in the direction of arrow **Z**, until the connecting rod or shaft **156** moves in the direction of arrow **Y2** away from the motor **152** and towards the flexible or compressible diaphragm **158** such that the flexible or compressible diaphragm **158** moves also in the direction of arrow **Y2** towards the interior volume **V'**, thereby causing an increase in pressure within the interior volume **V'** of the proximal pump portion **142**. The increase in pressure causes the suction flow interruption device **164** to close and the pump portion discharge flow path flow interruption device **168** to open, thereby causing air flow through the central parameter sensing portion **120'** and the distal probe portion **110** through the distal tip **112**.

[0125] When restriction orifice **140** is deployed and disposed in the central parameter sensing portion **120'**, which, as indicated above, serves also as a discharge flow path for the proximal pump portion **142**, a low pass filter function is performed by volume **V''** between pump portion discharge flow path flow interruption device **168** and restriction orifice **140**. Thus, when restriction orifice **140** is deployed, pump portion discharge flow path flow interruption device **168** must be upstream of the restriction orifice **140**. As a result, high frequency pulsations are filtered out of the air flow to the distal tip **112**.

[0126] The piston or plunger **126**, **126'** of pump portion **124** of FIGS. **4A** and **4B** and liquid diaphragm pump **150** of FIG. **4C** are examples of positive displacement pumps or compressors which may be employed to cause the desired changes in pressure at the distal tip **112** or the distal probe portion **110**. Other types of positive displacement pumps or compressors, as well as centrifugal pumps or other types of pumps known in the art may be employed to cause the desired changes in pressure or flow at the distal tip **112**.

[0127] FIG. **6** shows pressure amplitude data as a function of the distance **d1** or **d2** between probe tip **112** and surface **13** in FIG. **1** or surfaces **31** and **33** in FIG. **2**, measured for different surfaces. A plastic needle with 0.42 mm inner diameter was used. Clear differences are visible at distances up to 0.6 mm, where the most hydrophobic surface (Teflon) gives the largest pressure signal, while the most hydrophilic surface (plaque) gives the lowest signal.

[0128] It should be noted that the data presented in FIGS. **5** and **6** were taken without the inclusion of restriction orifices.

[0129] FIGS. **1-6** have described a first method of detecting the presence of a substance on a surface, which includes the measurement of bubble release from a tip (by pressure and/or pressure variations and/or bubble size and/or bubble release rate) as a method of detecting, for example, dental plaque at the probe tip **112**. As described above with respect to FIGS. **1** and **2** and **6**, the probe tip **112** is positioned at a distance **d1** or **d2** away from the surface such as surface **13** in FIG. **1** or surfaces **31** and **33** in FIG. **2**.

[0130] It should be noted that although the method of bubble generation and detection has been described with respect to the second fluid being a gas such as air, the method may also be effective when the second fluid is a liquid, wherein water droplets instead of gas bubbles are created.

[0131] Additionally, the method may be effected with constant pressure and measurement of the variable fluid

outflow. The apparatus may record the variable pressure and/or the variable flow of the second fluid. In one exemplary embodiment, the pressure is recorded and the flow of the second fluid is controlled, e.g., the flow is kept constant. In another exemplary embodiment, the flow is recorded and the pressure of the second fluid is controlled, e.g., the pressure is kept constant.

[0132] In a second method of detecting the presence of a substance on a surface according to the exemplary embodiments of the present disclosure, FIG. **7** illustrates the influence of blocking of the probe tip **112** of the probe **110** of FIG. **4A**, **4B** or **4C**. The probe or stream probe tubular member or stream probe **110'** illustrated in FIG. **7** includes a proximal end **138** and interior channel **134**. The stream probe or stream probe tubular member **110'** differs from stream probe **110** in FIG. **4A**, **4B** or **4C** in that the stream probe **110'** includes a chamfered or beveled distal tip **112'** having an open port **136** that is chamfered at an angle α with respect to the horizontal surface **31** or **33** such that passage of the second fluid medium through the distal tip **112**, now designated as second fluid medium **30'** since it has exited from the distal tip **112'**, is enabled when the distal tip **112'** touches the surface **31** or **33** and the second fluid medium **30'** is also enabled to flow through the chamfered open port **136**. The angle α of the chamfer of the open port **136** is such that passage of the second fluid medium **30'** through the distal tip **112'** is at least partially obstructed when the distal tip **112'** touches the surface **31** or **33** and a substance **116**, such as viscoelastic material **116**, at least partially obstructs the passage of fluid through the open port **136** of the distal tip **112'**. Although only one probe **110'** is required to detect obstruction of the passage of fluid, in one exemplary embodiment, it may be desired to deploy at least two probes **110'** as a system **3000** to detect obstruction of the passage of fluid (see the discussion below for FIGS. **13-17** and FIGS. **19-21**).

[0133] Alternatively, the probe tips **112** of FIG. **1**, **2**, **4A** or **4B** are utilized without chamfered or beveled ends and simply held at an angle (such as angle α) to the surface **31** or **33**. In one exemplary embodiment, the substance has a nonzero contact angle with water. In one exemplary embodiment, the substance with a nonzero contact angle with water is enamel.

[0134] As illustrated on the left portion of FIG. **7**, when the probe tip **112'** becomes blocked by viscoelastic material **116** from the dental surface **31**, then the fluid such as gas **30** will flow less easily out of the tip **112'**, as compared to when probe tip **112'** is not blocked (second fluid medium **30'**) and is without dental material at the tip **112'** or at dental surface **33**, as illustrated in the right portion of FIG. **7**.

[0135] FIG. **8** illustrates pressure signals of a probe tip, e.g., a metal needle with a bevel, moving on enamel without plaque, as illustrated on the left, and on a sample with a plaque layer, as illustrated on the right. The increase in pressure seen in the right portion, attributed to obstruction of the needle opening by the plaque, can be sensed to detect if plaque is present.

[0136] FIG. **9** illustrates pressure signals of an airflow from a Teflon tip moving over water, region **1**, PMMA (polymethyl methacrylate) region **2**, PMMA with plaque region **3**, and water region **4**. The tip moves (from left to right) over water region **1**, PMMA region **2**, PMMA with plaque region **3**, and again over water region **4**. The Teflon tip is not shown). When reference is made to pressure

differences herein, consideration of the following should be taken into account. In FIG. 8, the fluid stream 30 is obstructed when the pressure increases on the left panel. So the parameter of interest is the average pressure or average or momentary peak pressure.

[0137] In contrast, FIG. 9 illustrates identical signals for a smaller probe tip, in which case a much smoother signal is obtained.

[0138] The data presented in FIGS. 8 and 9 were taken without the inclusion of restriction orifices.

[0139] In preliminary experiments according to FIG. 2, we have observed the following:

[0140] Dental plaque (in wet state) is more hydrophilic than clean enamel, as shown in FIG. 3.

[0141] The release of air bubbles from the tip is measurable by pressure variations. A syringe with constant displacement velocity gives a sawtooth-like signal of pressure as a function of time. This is shown in the oscilloscope photograph in FIG. 5.

[0142] In case of close approach between tip and surface, the amplitude of the sawtooth signal is smaller when the probed surface is more hydrophilic than when the surface is less hydrophilic. So, smaller air bubbles are released on the more hydrophilic surface. This is also demonstrated by the measurements in FIG. 6, where the pressure signal amplitude as a function of distance d_1 or d_2 from the tip to the surface (see FIGS. 1 and 2) is given for different surfaces.

[0143] In preliminary experiments according to FIG. 7, we have observed the following:

[0144] An unblocked tip gives a regular release of air bubbles and a sawtooth-like pattern of pressure versus time, when a syringe is used with a constant displacement velocity. See the left panel of FIG. 8.

[0145] In an experiment with a metal tip moving through plaque material, an increase of pressure and an irregular sawtooth-like pattern of pressure versus time was observed, due to blocking of the tip by plaque material and opening of the tip by the air. See the right panel of FIG. 8.

[0146] In an experiment with a Teflon tip, clear signal differences were seen for different materials at the tip opening (from left to right: tip in water, tip above PMMA, above PMMA with plaque, and again tip in water).

[0147] These preliminary experiments indicate that the measurement of bubble release from a tip (by pressure and/or pressure variations and/or bubble size and/or bubble release rate) may become a suitable method to detect dental plaque at the tip. Accordingly, in view of the foregoing, at a minimum, the novel features of the exemplary embodiments of the present disclosure are characterized in that:

[0148] (a) fluid medium 14 is brought in contact with surface 13 at probe tip 12, generating interaction zone 17 between tip 12 and surface 13 (see FIG. 1); and (b) the shape and/or dynamics of the medium 14 in the interaction zone 17 depend on the properties of the surface 13 and/or on materials derived from the surface 13; and (c) the pressure and/or shape and/or dynamics of the medium 14 in the interaction zone 17 are detected.

[0149] In view of the foregoing description of the two differing methods of detecting the presence of a substance on a surface, the proximal pump portion 124 in FIGS. 4A and 4B effectively functions as a syringe. During injection of the plunger 126 or 126' distally, gas or air flow or liquid flow at

the tip 112 in FIGS. 4A and 4B, or tip 112' in FIG. 7, can be pushed outwardly away from the tip (when the plunger is pushed).

[0150] During retraction or reverse travel of the plunger 126 or 126', gas or air flow or liquid flow can be suctioned inwardly at the tip 112 or 112' and in towards the probe tube 110 or 110'. In one exemplary embodiment, the plunger 126 or 126' is operated automatically together with the vibration of the bristles of an electric toothbrush or where the bristles are not vibrating (e.g. using the same principle in a dental floss device).

[0151] Accordingly, the syringe or pump 124 can be used for the stream method in which flow of gas or air is injected away from the tip 112 and towards the enamel to generate bubbles 32 or 34. The bubbles and locations are detected optically and depending on whether the surface is more hydrophilic such as plaque or less hydrophilic such as enamel, the location of the bubble will determine whether there is plaque present. That is, the surface has a hydrophilicity which differs from the hydrophilicity of the substance to be detected, e.g., enamel has a hydrophilicity which is less than the hydrophilicity of plaque. The tip 112 is located at a particular distance d_2 (see FIG. 2) away from the enamel regardless of whether plaque is present or not.

[0152] Alternatively, pressure sensing can also be used for the bubble method. Referring also to FIG. 2 and FIG. 4A, the same pump portion 124 functioning as a syringe can be used for the pressure sensing method as follows. Fluid is injected towards the enamel surface 31 or 33. The probe tip 112 is initially located at a particular dimension away from the enamel surface such as d_2 in FIG. 2. The pressure signal is monitored as illustrated and described above in FIGS. 5 and 6. Bubble release measurements are performed by pressure and/or pressure variations as described above.

[0153] In the second method of detecting the presence of a substance on a surface according to the exemplary embodiments of the present disclosure, as illustrated in FIG. 7, the passage of the second fluid such as gas 30 through the distal tip 112 enables detection of substance 116 that may be present on the surface 31 based on measurement of a signal, correlating to a substance at least partially obstructing the passage of fluid through the open port of the distal tip 112'. The signal may include an increase or decrease in pressure or change in other variable as described above.

[0154] Since in one exemplary embodiment at least two probes 110' are utilized, FIG. 7 illustrates a system 300 for detecting the presence of a substance on a surface. In one exemplary embodiment, the probes 110' are in contact with the surface 31 or 33 as described above. If there is no plaque at the surface 33, i.e., flow is unblocked, then the pressure signal is as shown in FIG. 8, left panel. If there is plaque at the surface, e.g., viscoelastic material 116, then the pressure signal is as shown in FIG. 8, right panel.

[0155] For practical applications, it is contemplated that the probe or probes 110' have a very small diameter, e.g., less than 0.5 millimeters, such that by their spring function, the probe tips 112' will make contact with the tooth surface 33. So when reaching the plaque the tube is pressed into this layer of plaque. The pressure signals illustrated in FIG. 8 were obtained with a single probe in contact.

[0156] Referring again to FIG. 7, in an alternate exemplary embodiment of the second method of detecting the presence of a substance on a surface, fluid is suctioned away from the enamel surface by reverse travel of the plunger 126

or 126' proximally towards the proximal end 124' of the proximal pump portion 124' in FIGS. 4A and 4B. Fluid or gas inflow 30 now becomes fluid or gas outflow 35 as illustrated by the dotted arrows (shown outside of the interior channel 134 for simplicity). If there is plaque 116 present, the plaque either is large enough to block the aperture at the probe tip or is small enough to be suctioned inside the probe channel. The pressure signal becomes an inverted version of FIG. 8. Lower pressure will be obtained in the presence of plaque.

[0157] As defined herein, regardless of the direction of flow of the second fluid through the probe tip, obstruction can mean either a direct obstruction by a substance at least partially, including entirely, blocking the tip itself or obstruction can mean indirectly by the presence of a substance in the vicinity of the probe tip opening thereby perturbing the flow field of the second fluid.

[0158] In addition to performing the first and second methods by maintaining a constant velocity of the plunger, the methods may be performed by maintaining constant pressure in the proximal pump portion and measuring the variable outflow of the second fluid from the probe tip. The readout and control can be configured in different ways. For example, the apparatus may record the variable pressure and/or the variable flow of the second fluid. In one exemplary embodiment, the pressure is recorded and the flow of the second fluid is controlled, e.g., the flow is kept constant. In another exemplary embodiment, the flow is recorded and the pressure of the second fluid is controlled, e.g., the pressure is kept constant.

[0159] Additionally, when two or more probes 110' are deployed for system 300, one of the probes 110' may include pressure sensing of the flow of the second fluid through the distal probe tip 112' while another of the probes 110' may include strain sensing or flow sensing.

[0160] Additionally, for either the first method of bubble detection or the second method of obstruction, although the flow of the second fluid is generally laminar, turbulent flow of the second fluid is also within the scope of present disclosure.

[0161] FIG. 10 illustrates a detection apparatus or instrument for detecting the presence of a substance on a surface according to one exemplary embodiment of the present disclosure wherein the detection apparatus is exemplified by the integration of the stream probe into a dental apparatus such as a tooth brush, forming thereby a detection apparatus for detecting the presence of a substance on a surface.

[0162] Traditionally an electric toothbrush system, such as the Philips Sonicare toothbrush mentioned above, comprises a body component and a brush component. Generally, the electronic components (motor, user interface UI, display, battery etc.) are housed in the body, whilst the brush component does not comprise electronic components. For this reason, the brush component is easily exchangeable and replaceable at a reasonable cost.

[0163] In one exemplary embodiment, detection apparatus or instrument 200, e.g., a dental cleaning instrument such as an electric toothbrush, is configured with a proximal body portion 210 and a distal oral insertion portion 250. The proximal body portion 210 defines a proximal end 212 and a distal end 214. The distal oral insertion portion 250 defines a proximal end 260 and a distal end 262. The distal end 262 includes a vibrating brush 252 with brush base 256 and bristles 254 and a distal portion of an air stream probe or a

liquid stream probe such as air stream probe 100 described above with respect to FIG. 4A or 100' with respect to FIG. 4B. In conjunction with FIG. 4A, 4B or 4C, the detection apparatus 200 is configured such that active components, e.g., mechanical, electrical or electronic components, are incorporated within, or disposed externally on, the proximal body portion 210, whilst the passive components such as distal probe portion 110, are incorporated within, or disposed externally on, a distal portion, exemplified by, but not limited to, distal oral insertion portion 250. More particularly, probe tip 112 of probe 110 is incorporated close to or within the bristles 254 so as to intermingle with the bristles 254, while the central parameter sensing tubular portion 120 and the proximal tubular syringe portion 124 are incorporated within, or disposed externally on, proximal body portion 210. Thus, the distal probe portion 110 is at least partially in contact with the distal oral insertion portion 250. A portion 111 of the distal probe tip 110 is disposed on the proximal body portion 210 and thus is a proximal probe portion.

[0164] In one exemplary embodiment, the distal oral insertion portion 250, including the brush 252 that includes brush base 256 and bristles 254, is exchangeable or replaceable. That is, the proximal body portion 210 is removably attachable to the distal oral insertion portion 250.

[0165] Contact to the proximal body portion 210 with the active parts by the distal oral insertion portion 250 is provided by a mechanical connection 230 on the proximal body portion 210 that is disposed to interface the distal end 214 of proximal body portion 210 and proximal end 260 of distal oral insertion portion 250, thereby interfacing the portion 111 of the distal probe tip 110 with distal probe tip 110 disposed on the distal oral insertion portion 250 such that an air stream is generated and the pressure is sensed, such as at the location of parameter sensor P2 in FIG. 4B or parameter sensors P in FIG. 4A or 4C. Based on the pressure sensor signal, it is concluded if plaque is present at the area of the probe tip 112. Thus, the proximal body portion 210 is removably attachable to the distal probe portion, illustrated in FIG. 10 as the distal oral insertion portion 250, via the mechanical connection 230. Those skilled in the art will recognize that, although the detection apparatus or instrument 200 is illustrated in FIG. 10 such that the distal oral insertion portion 250 and the proximal body portion 210 are removably attachable from one another, and thus either one is replaceable, the detection apparatus or instrument 200 can be configured or formed as a unitary, integrated combined apparatus or instrument wherein the distal oral insertion portion 250 and the proximal body portion 210 are not readily detachable from one another.

[0166] In addition, the stream probes 100, 100' or 100'' may be utilized independently without including the brush 252, the brush base 256, or the bristles 254, such as illustrated in FIGS. 4A, 4B and 4C. The detection apparatus or instrument 200 may be applied either with or without the brush 252, the brush base 256, or the bristles 254 both to dental and non-dental applications to detect the presence of a substance on a surface.

[0167] When the detection apparatus or instrument 200 is designed as a dental cleaning instrument, the probe 110 may be dimensioned and made from materials selected so as to yield a rotational stiffness that is generally equivalent to the rotational stiffness of the bristles 254 such that the probe 110 sweeps an area during operation generally equivalent to the

sweep area and timing of the bristle operation so as to reduce any potential discomfort to the user. The variables contributing to the design of the stiffness include the dimensions, the mass and the modulus of elasticity of the material selected.

[0168] In one exemplary embodiment, the active components comprise the pressure sensor P as described above. In conjunction with FIG. 1, the sensor P is used to sense the shape and/or dynamics of the medium 14 in the interaction zone 17. Such a sensor has the advantage that it is robust and simple to use. The sensor P is in electrical communication with detection electronics 220 that include a controller 225 that is in electrical communication therewith.

[0169] In an alternate exemplary embodiment, the active component may comprise an optical, electrical or acoustic sensor such as, for example, a microphone, in order to sense the shape and/or dynamics of the medium 14 in the interaction zone 17.

[0170] The controller 225 can be a processor, microcontroller, a system on chip (SOC), field programmable gate array (FPGA), etc. Collectively the one or more components, which can include a processor, microcontroller, SOC, and/or FPGA, for performing the various functions and operations described herein are part of a controller, as recited, for example, in the claims. The controller 225 can be provided as a single integrated circuit (IC) chip which can be mounted on a single printed circuit board (PCB). Alternatively, the various circuit components of the controller, including, for example, the processor, microcontroller, etc. are provided as one or more integrated circuit chips. That is, the various circuit components are located on one or more integrated circuit chips.

[0171] Furthermore, the active components enable a method of generating an air or liquid stream. A combined air with liquid stream is possible as well. The method may comprise an electrical or a mechanical pumping method, whereby the mechanical method may comprise a spring component which is mechanically activated, e.g., wherein plunger 126 in FIG. 4 is mechanically activated. In one exemplary embodiment, the method of generating the air stream is an electrical pumping principle, as this combines well with the pressure sensing component described above. In other exemplary embodiments, air may be replaced by other gases, e.g., nitrogen or carbon dioxide. In such exemplary embodiments, while the proximal body portion 210 may include the proximal pump portion 124 and the plunger 126 or other types of pumps to generate either constant pressure or constant flow of fluid, the proximal body portion 210 may include a container of compressed gas (not shown) that is sized to fit within the proximal body portion 210 and is capable of providing either constant pressure or constant flow via a valve control system (not shown).

[0172] In yet another exemplary embodiment, the passive components comprise only a tube with an opening at the end, such as probe 110 and distal tip 112 (see FIG. 10).

[0173] In still another exemplary embodiment, connection of the active and passive components is realized by a mechanical coupling 230 of the tube to the output of the pressure sensor. Such a coupling is ideally substantially pressure sealed. Pressure values are relatively low (<<1 bar).

[0174] In operation, the sensing is carried out in a repetitive manner during the tooth brushing process. In a preferred exemplary embodiment, sensing is carried out at a frequency >1 Hz, more preferably >5 Hz and even more preferably >10

Hz. Such a high frequency embodiment facilitates the dynamic and real time measurement of plaque removal as the toothbrush is moved from tooth to tooth, as several measurements may be made on an individual tooth (the dwell time on a given tooth is typically of the order of 1-2 seconds).

[0175] In conjunction with FIG. 1, as described above, the shape and/or dynamics of the medium 14 in the interaction zone 17 depend on the properties of the surface 13 and/or on materials derived from the surface 13, the pressure and/or shape and/or dynamics of the medium 14 in the interaction zone 17 are detected and a determination is made by the controller 225 as to whether a level of plaque exceeding a predetermined maximum permissible level of plaque is detected at the particular dental surface 13.

[0176] If a positive detection is made, no progression or advancement signal is transmitted to the user of the electric toothbrush until a predetermined maximum permissible plaque level is achieved at the particular dental surface 13 by continued cleaning at the dental surface 13 of that particular tooth.

[0177] Upon reduction of the level of plaque to at or below the maximum permissible plaque level, i.e., a negative detection is made, a progression signal or advancement signal is transmitted to the user to inform the user that it is acceptable to progress to an adjacent tooth or other teeth by moving the vibrating brush and probe tip of the dental apparatus.

[0178] Alternatively, if a positive detection is made, a signal is transmitted to the user of the electric toothbrush having an integrated stream probe plaque detection system to continue brushing the particular tooth.

[0179] Furthermore, there are several preferred modes of operation of the passive component in the brush.

[0180] In a first mode operation, the tube is configured such that the tip of the tube is acoustically uncoupled from the vibration of the brush (which vibrates at about 265 Hz in a Philips Sonicare toothbrush). This may be achieved by only weakly coupling the tube to the brush head.

[0181] In a further mode of operation, the tube is configured such that the tip of the tube is static. This may be achieved by choosing the mechanical properties of the tube (stiffness, mass, length) such that the tip of the probe is at a static node of vibration at the driving frequency. Such a situation may be helped by adding additional weight to the end of the tube close to the opening.

[0182] As illustrated in FIG. 11, which is a partial cross-sectional view of distal oral insertion portion 250 in FIG. 10, in a further exemplary embodiment, the effect of the motion of bristles of the toothbrush on the sensing function is reduced by incorporating a spacing 258 around the tube where the bristles are removed. More particularly, probe 110 in FIG. 11 illustrates a brush head 252 that includes base 256 and bristles 254 that protrude generally orthogonally from the base 256. Spacing 258 is positioned with removed bristle wires around probe tip 1121. The probe tip 1121 differs from probe tips 112 and 112' in that probe tip 1121 includes a 90 degree elbow 1122 so as to enable fluid flow through the probe 110 towards the surface 31 or 33.

[0183] In one exemplary embodiment, the spacing 258 should be of the order of the amplitude of the vibration of the bristles 254. In practice, the bristles vibrate with an amplitude of around 1-2 mm. This makes the sensing more robust.

[0184] In a further exemplary embodiment, as illustrated in FIG. 12, the probe tip 1121 is situated distally beyond the area covered by the bristles 254. This makes it possible to detect plaque which is present beyond the present position of the brush, for example plaque which has been missed by an incomplete brushing action.

[0185] As a further detail, ideally the angle of the brush 252 while brushing is 45 degrees with respect to the tooth surface 31 or 33. Ideally the angle of the probe tip 1121 is close to 0 degrees with respect to the tooth surface 31 or 33. At least two probes 110 and correspondingly at least two pressure sensors and two pumps with a tip end 1121 of 45 degrees with respect to the tooth surface 31 or 33, so that always one probe is interfacing optimally the surface 31 or 33.

[0186] In still a further exemplary embodiment, a plurality of probes are incorporated in the brush. These probes may alternatively be disposed or utilized at least as follows:

[0187] (a) positioned at multiple positions around the brush, to sense for (missed) plaque more effectively, or

[0188] (b) used for differential measurements to determine the degree and effectiveness of the plaque removal.

[0189] In one exemplary embodiment, the plurality of probes may be realized with a single active sensing component and a multiplicity of passive components, such as tubes, attached to a single pressure sensor. Alternatively, a plurality of active and passive sensing components may be used.

[0190] The end of the tube may have many dimensions, as described above. In alternative exemplary embodiments, the tip of the tube will be spaced from the surface of the tooth using a mechanical spacer. In some exemplary embodiments, the opening may be made at an angle to the tube.

[0191] FIGS. 13-22 illustrate examples of a detection system 3000 for detecting the presence of a substance on a surface that employs the foregoing principles for detecting the presence of a substance on a surface via multiple stream probes. More particularly, in one exemplary embodiment of the present disclosure, the system 3000 includes a detection apparatus 1100 for detecting the presence of a substance on a surface such as an air stream probe having proximal pump portion 124 and plunger 126 as described above with respect to FIG. 4A and FIG. 10. It should be noted, however, that in lieu of proximal pump portion 124 and plunger 126, proximal pump portion 142 and diaphragm pump 150, as described above with respect to FIG. 4C, may also be deployed to provide a generally continuous flow 1100 for detecting the presence of a substance on a surface in a similar manner as described below with respect to the proximal pump portion 124 and plunger 126.

[0192] The proximal pump portion 124 includes a central parameter sensing tubular portion 120' configured with a distal tee connection 101 defining a first leg 1011 and a second leg 1012. First stream probe 301 having a distal probe tip 3112 is fluidically coupled to the first leg 1011 and second stream probe 302 having a distal probe tip 3122 is fluidically coupled to the second leg 1012.

[0193] A pressure sensor P3 is connected to the first leg 1011 via branch connection 312 in the vicinity of the first stream probe 301 and a pressure sensor P4 is connected via branch connection 322 in the vicinity of second stream probe 302 to the second leg 1012. In a similar manner as with respect to stream probe 100 described above with respect to FIG. 4A, stream probe 100' described above with

respect to FIG. 4B and stream probe 100" described above with respect to FIG. 4C, the stream probe 1100 may include a restriction orifice 3114 disposed in first leg 1011 downstream of junction 314 between central parameter sensing tubular portion 120' and the first leg 1011 and upstream of first stream probe 301 and pressure sensor P3. Similarly, a restriction orifice 3124 may be disposed in second leg 1012 downstream of junction 324 between central parameter sensing tubular portion 120' and the second leg 1012 and upstream of second stream probe 302 and pressure sensor P4. Again, the presence of the restriction orifices 3114 and 3124 improves the response time of the pressure meters P3 and P4 since only the volume of the stream probe 1100 downstream of the restriction orifices 3114 and 3124 is relevant. The air flow into each pressure sensor P3 and P4 becomes approximately independent since the pressure drops occur predominantly across the restriction orifices 3114 and 3124 and the stream probe 1100 behaves more closely or approximately as a flow source rather than a pressure source. The volume upstream of the restriction orifice 240 becomes less relevant. The pressure sensors P3 and P4 can each generally sense a pressure rise separately while being driven by single plunger 126.

[0194] Additionally, those skilled in the art will recognize that the restriction of flow via orifices 3114 and 3124 may be effected by crimping the distal tee connection 101 in the vicinity of the junctions 314 and 324 in lieu of installing a restriction orifice. Again, as defined herein, a restriction orifice includes a crimped section of tubing.

[0195] In a similar manner as described above with respect to detection apparatus 200 illustrated in FIG. 10, the sensors P3 and P4 are in electrical communication with detection electronics and a controller such as detection electronics 220 that include controller 225 that is in electrical communication therewith (see FIG. 10).

[0196] Upon detection of plaque by the detection electronics 220, the controller 225 generates a signal or an action step. Referring to FIG. 10, in one exemplary embodiment, the controller 225 is in electrical communication with an audible or visible alarm 226 located on the such as a constant or an intermittent sound such as a buzzer and/or a constant or intermittent light that is intended to communicate to the user to continue brushing his or her teeth or the subject's teeth at that particular location.

[0197] In one exemplary embodiment, based upon the signals detected by the detector electronics 220, the controller 225 may record data to generate an estimate of the quantity of plaque that is present on the teeth. The data may be in the form of a numerical quantity appearing on a screen 125 in electrical communication with the detector electronics 220 and the controller 225. The screen 125 may be located on, or extending from, the proximal body portion 210 as illustrated in FIG. 10. Those skilled in the art will recognize that the screen 125 may be located at other positions suitable for the user to monitor the data presented on the screen.

[0198] The signaling to the user may include the controller 225 configured additionally as a transceiver to transmit and receive a wireless signal 228' to and from a base station 228 with various indicators on the base station that generate the signal to trigger the audible or visual alarm 226 or to record the numerical quantity or other display message such as an animation on the screen 125.

[0199] Alternatively, the controller 225 may be configured additionally as a transceiver to transmit and receive a wireless signal 229' to a smart phone 229 that runs application software to generate animations on a screen 231 that signal that plaque has been identified and instruct the user to continue brushing in that location. Alternatively, the application software may present quantitative data on the amount of plaque detected.

[0200] FIGS. 14-16 illustrate an alternate distal oral insertion portion 350 that includes a brush 352 with bristles 354 mounted on brush base 356, and as illustrated in FIG. 14 as viewed looking towards the brush base 356 and the upper tips of the bristles 354. As best illustrated in FIGS. 15 and 16, extending generally orthogonally from horizontal upper surface 356' of brush base 356 are distal probe tips 3112 and 3122 which enable multiple fluid flows to be directed towards the surface of interest such as surfaces 31 and 33 in FIGS. 2 and 7. Alternate or additional positions for distal probe tips 3112 and 3122 are illustrated by the dotted lines in the vicinity of the proximal end of the brush base 356 in FIG. 14.

[0201] In a similar manner, FIGS. 17-19 illustrate system 3010 for detecting the presence of a substance on a surface that differs from system 3000 in that system 3010 includes another alternate distal oral insertion portion 360 that includes the brush 352 with bristles 354 mounted on brush base 356, and as illustrated in FIG. 17 as viewed looking towards the brush base 356 and the upper tips of the bristles 354. As best illustrated in FIG. 19, each extending at an angle β with respect to the horizontal upper surface 356' of brush base 356 are distal probe tips 3212 and 3222 which enable multiple fluid flows to be directed at angle β towards the surface of interest such as surfaces 31 and 33 in FIGS. 2 and 7. In a similar manner, alternate or additional positions for distal probe tips 3212 and 3222 are illustrated by the dotted lines in the vicinity of the proximal end of the brush base 356 in FIG. 17.

[0202] The distal oral insertion portions 350 and 360 illustrated in FIGS. 14-16 and FIGS. 17-19 may be utilized for either: (a) the first method of detecting the presence of a substance on a surface which includes the measurement of bubble release from a tip (by pressure and/or pressure variations and/or bubble size and/or bubble release rate), or (b) for the second method of detecting the presence of a substance on a surface which includes the passage of the second fluid such as a gas or a liquid through the distal tip based on measurement of a signal, correlating to a substance obstructing the passage of fluid through the open port of the distal tip.

[0203] FIGS. 20-22 illustrate exemplary embodiments of the system 3000 or system 3010 that includes multiple stream probes and corresponding proximal pump portions that may be operated by a common rotating shaft and motor. More particularly, FIG. 20 illustrates a first stream probe operating apparatus 3100 that includes first stream probe 3100'. First stream probe 3100' is identical to the stream probe 100' described above with respect to FIG. 4B and may include the proximal pump portion 124 and plunger 126 and either the distal probe tip 3112 (see FIGS. 14-16) or the distal probe tip 3212 (see FIGS. 17-19). A rotary to linear motion operating member 3102, which may be a cam mechanism as illustrated, is in operable communication with

the plunger 126 via a reciprocating shaft 3106 and a roller mechanism 3108 disposed on the proximal end of the shaft 3106.

[0204] The roller mechanism 3108 engages in a channel 3110 defining a path on the periphery of the cam mechanism 3102. The channel 3110 extends along the path to include cam peaks 3102a and cam troughs 3102b. The cam mechanism 3102 is mounted on and rotated by a common shaft 3104, in a direction such as the counterclockwise direction illustrated by arrow 3120. As the cam mechanism 3102 rotates, a reciprocating linear motion is imparted to the shaft 3106 as the roller mechanism 3108 is intermittently pushed by the peaks 3102a or pulled into the troughs 3102b. Thereby, a reciprocating linear motion is imparted to the plunger 126, pressure is generated in the stream probe 3100', and fluid flow passes through the distal tips 3112 or 3212. Those skilled in the art will understand that the path defined by the channel 3110 may be designed to impart a generally constant velocity to the plunger 126. Alternatively, the path defined by the channel 3110 may be designed to impart a generally constant pressure in the proximal pump portion 124. The plunger 126 is at a position distally away from the proximal end 124' of the proximal plunger portion 124 since the roller mechanism 3108 is at a peak 3102a.

[0205] FIG. 21 illustrates a second stream probe operating apparatus 3200 that includes second stream probe 3200'. Second stream probe 3200' is also identical to the stream probe 100' described above with respect to FIG. 4B and may include the proximal pump portion 124 and plunger 126 and either the distal probe tip 3122 (see FIGS. 14-16) or the distal probe tip 3222 (see FIGS. 17-19). Again, a rotary to linear motion operating member 3202, which may be a cam mechanism as illustrated, is in operable communication with the plunger 126 via a reciprocating shaft 3206 and a roller mechanism 3208 disposed on the proximal end of the shaft 3206.

[0206] Similarly, the roller mechanism 3208 engages in a channel 3210 defining a path on the periphery of the cam mechanism 3202. The channel 3210 extends along the path to include cam peaks 3202a and cam troughs 3202b. The cam mechanism 3202 is mounted on and rotated by a common shaft 3204, in a direction such as the counterclockwise direction illustrated by arrow 3220. As the cam mechanism 3202 rotates, a reciprocating linear motion is imparted to the shaft 3206 as the roller mechanism 3208 is intermittently pushed by the peaks 3202a or pulled into the troughs 3202b. Thereby, a reciprocating linear motion is also imparted to the plunger 126, pressure is generated in the stream probe 3200', and fluid flow passes through the distal tips 3122 or 3222. Again, those skilled in the art will understand that the path defined by the channel 3210 may be designed to impart a generally constant velocity to the plunger 126. Again, alternatively, the path defined by the channel 3210 may be designed to impart a generally constant pressure in the proximal pump portion 124. In contrast to first stream probe operating apparatus 3100, the plunger 126 is at a position at the proximal end 124' of the proximal plunger portion 124 since the roller mechanism 3208 is now at a trough 3202b.

[0207] FIG. 22 illustrates a motor 3300 that is operably connected to the common shaft 3104 such that the first rotary to linear motion operating member 3102 of stream probe operating apparatus 3100 is mounted proximally on the common shaft 3104 with respect to the motor 3300 while the

second rotary to linear motion operating member 3202 of stream probe operating apparatus 3200 is mounted distally on the common shaft 3104 with respect to the motor 3300. Those skilled in the art will recognize that rotation of the common shaft 3104 by the motor 3300 causes the multiple stream probe operation as described above with respect to FIGS. 20 and 21. The motor 3300 is supplied electrical power by a power supply 270 mounted on proximal body portion 210 (see FIG. 10) such as a battery or ultracapacitor or alternatively a connection to an external power source or other suitable means (not shown).

[0208] Those skilled in the art will recognize that either stream probe operating apparatus 3100 or stream probe operating apparatus 3200 may operate the single air stream probe 1100 with multiple distal probe tips 3112 and 3122 described above with respect to FIG. 13 or the multiple distal probe tips 3212 and 3222 described above with respect to FIGS. 17-19.

[0209] Those skilled in the art will recognize that the stream operating apparatuses 3100 and 3200 described with respect to FIGS. 20-22 are merely examples of apparatuses which may be employed to effect the desired operation. For example, those skilled in the art will recognize that stream probe 100" and its associated components may replace the plunger 126 and either rotary to linear motion operating member 3102 or rotary to linear motion operating member 3202 or both and motor 3300 may be replaced by the diaphragm pump 150 that includes flexible or compressible diaphragm 158 as described above with respect to FIG. 4C.

[0210] The motor 3300 is in electrical communication with the controller 225 which controls the motor operation based on the signals received by the detector electronics 220. In addition to the alarm 226, the screen 125, the base station 228 and the smart phone 229 described above with respect to FIG. 10, in conjunction with FIG. 10, signaling to the user that plaque has been detected may include the controller 225 programmed to change the toothbrush drive mode by varying the operation of the motor 3300 to increase the brushing intensity either in frequency or in amplitude, or both, when plaque is detected. The increase in amplitude and/or frequency both signal to the user to continue brushing in that area, and thus improves effectiveness of plaque removal. Alternatively, the controller 225 may be programmed to create a distinct sensation in the mouth that the user can distinguish from regular brushing, for example, by modulating the drive train to signal that plaque has been located.

[0211] The supply of air bubbles to a tooth brush may also improve the plaque removal rate of the brushing.

[0212] One possible mechanism is that (i) air bubbles will stick to spots of clean enamel, (ii) brushing brings a bubble into motion, and thereby also the air/water interface of the bubble, and (iii) when the bubble edge contacts plaque material, the edge will tend to peel the plaque material off the enamel, because the plaque material is very hydrophilic and therefore prefers to stay in the aqueous solution. Another possible mechanism is that the presence of bubbles can improve local mixing and shear forces in the fluid, thereby increasing the plaque removal rate. It should be noted that other exemplary embodiments of the methods of detection of a substance on a surface as described herein may include monitoring the first derivative of the signals, AC (alternating current) modulation, and utilization of a sensor for gum detection.

[0213] Other matters to be considered are that particles, particularly particles in toothpaste, may block the tiny opening of the stream probe, which may have a cross-sectional dimension as small as 200 microns (μm). Also dental plaque and saliva or food particles may block the opening of the probe. FIG. 23 illustrates an actual photograph of a distal tip 112 of a distal probe portion 110 that is a Teflon tube with open port 136 such as illustrated in FIGS. 4A and 4B and FIG. 10. In FIG. 24, open port 136 has been blocked after some experiments with toothpaste that contains relatively large blue particles. Initially a partial blockage will occur resulting in an increase in pressure detected by the pressure sensors P, P1 or P2. This pressure increase will be interpreted by process controller 225 as plaque present on the location being brushed, while in fact the surface at the location is clean. Therefore, a false positive signal is generated (i.e., the user thinks there is plaque present when this is not the case). If the blockage does not clear, then the pressure increase will be continuous, and false readings may continue to occur. Finally, in the case of a full blockage as shown in FIG. 24, the distal probe portion 110, and thus the entire detection apparatus 200 will be unusable, as no flow can occur.

[0214] In exemplary embodiments of the present disclosure, the stream probe 100 of FIG. 4A or stream probe 100' of FIG. 4B incorporated into proximal body portion 210 of FIG. 10, which supply either positive pressure through the distal probe portion 110 or induce negative pressure in the distal probe portion 110, or stream probe 100" of FIG. 4C which includes pump portion 150 which generally supplies positive pressure through the distal probe portion 110 but if configured to induce negative pressure can induce negative pressure through distal probe portion 110, is adapted such that a dynamic pressure may be supplied to or induced in the stream probes 100 or 100' or 100" to overcome blocking by toothpaste particles, plaque particles or saliva. As defined herein, dynamic pressure refers to a time varying change in the stagnation pressure of the fluid at the distal tip 110 of the stream probe or a time varying change in the static pressure of the fluid at the distal tip 110 of the stream probe, wherein the fluid at the distal tip is either a gas, including air, or a liquid. The time varying change in stagnation pressure and in static pressure also includes alternating cycles of positive pressure and negative pressure. Thus, changes in dynamic pressure include changes in stagnation pressure or independent or related changes in static pressure or combinations thereof. Alternatively, dynamic pressure includes maintaining the pressure of the fluid generally constant until dislodgement of the substance or substances causing the blockage (following which a decrease in pressure of the fluid generally would be expected).

[0215] Overcoming blocking is achieved by introducing additional modes of operation to the stream probes 100 or 100' or 100" which, perhaps not as advantageous for the detection of plaque, either discourage blocking or facilitate unblocking of the stream probe.

[0216] These additional modes of operation include at least the following operating features:

[0217] Periodically pulsing an air pressure that is larger than the previous air pressure pulse;

[0218] Maintaining air pressure for a period of time after switching off the motion of the bristles;

[0219] Activating air flow after sensing motion of the brush that indicates the user is about to use the brush. That is, air is activated when the user first moves the brush after the air has been turned off;

[0220] Activating water flow through the stream probe when the brush is in use or in a storage or docking station;

[0221] Forcing flow of mouth wash disinfecting liquid through the stream probe when not in use; and

[0222] Intentionally applying an under-pressure to draw (cleaning) disinfecting liquid into the stream probe tube.

[0223] To implement one or more of the foregoing modes of operation, stream probe 100" of FIG. 4C may be configured to provide a dedicated mode of operation to reduce the occurrence of blockages or remove existing blockages of the stream probe whereby the air pressure in the distal probe portion exceeds that used in the plaque detection mode. The mode can be intermittently activated for periods either before, during or after brushing.

[0224] A relatively low air flow of approximately 100 mL/minute (milliliters/minute) and an associated low pressure (around 10 kPa—kiloPascal) are sufficient to reliably detect plaque. The low flow has the advantage that the user can hardly sense the air flow. Additionally, inexpensive pressure sensors are available to detect the low pressure. However, even inexpensive air pumps are capable of generating significantly higher pressures and flow rates—for example an order of magnitude higher. In this embodiment the toothbrush can switch into this mode of operation by the following:

[0225] Increasing the operation of the existing pump to increase flow by increasing the operating frequency and/or the amplitude of the driving signal (and thereby also increasing the pressure);

[0226] Decreasing the flow resistance of the probe by routing the flow through a lower flow resistance path—for example using wider tubing, avoiding passing the pressure sensor, avoiding the restriction which may be used into the device between a pressure chamber at the pump and the probe/pressure sensor part etc. Re-routing can be done by opening a tap or valve. In this manner, it is possible to increase flow (and thereby also increasing the pressure);

[0227] Switching to a separate pump with a higher pressure or higher flow mode of operation; or

[0228] Allowing pressure to build up in a holding chamber before releasing it suddenly (e.g. by opening a spring loaded valve) and creating a burst of high pressure fluid.

[0229] The foregoing modes of operation may be implemented individually or more than one of the modes or all of the modes may be implemented concurrently.

[0230] To exemplarily implement such additional modes of operation to overcome blocking or reduce the probability of blocking the distal probe portion 110, referring to FIG. 10 in conjunction with FIG. 4C, in one exemplary embodiment, detection apparatus for detecting the presence of a substance on a surface or stream probe 100" includes proximal body portion 210 that includes pump portion 142 and proximal probe portion 111. The pump portion 142 and the proximal probe portion 111 are in fluid communication with one another via a central parameter sensing portion 120' disposed in fluid communication between the pump portion 142 and the proximal probe portion 111. Thereby, the central parameter sensing portion 120' enables fluid communication between the pump portion 142 and the proximal probe portion 111. As shown in FIG. 10, the proximal probe

portion 111 may be connected via connector 230 to distal probe portion 110 of the detection apparatus to establish fluid communication between the proximal probe portion 111, the central parameter sensing portion 120' and the distal probe portion 110.

[0231] As described above with respect to FIG. 7, the detection apparatus 100" includes the distal probe portion 110 that is configured to be immersed in first fluid 11, Again,

[0232] the distal probe portion 110 defines distal tip 112 having an open port 136 to enable the passage of second fluid 30 through the distal tip 112.

[0233] The detection apparatus 100" is configured such that the pump portion 142 causes passage of the second fluid 30 through the distal tip 112 to induce a change in a sensing parameter in the distal probe portion 110 to enable detection of a substance 116 that may be present on the surface 31, 33 based on measurement of a signal representing the sensing parameter, e.g., pressure, flow rate or strain, that correlates to a substance 116 at least partially obstructing the passage of fluid 30 through the open port 136 of the distal tip 112. As also shown previously in FIG. 4C, parameter sensor P is configured and disposed in the central parameter sensing portion 120' to detect the signal representing the sensing parameter.

[0234] As before, controller 225 processes signal readings sensed by the parameter sensor P and determines whether the signal readings are indicative of a substance 116 obstructing the passage of fluid 30 through the open port of the distal tip 112. The controller 225 is in electrical communication with the pump portion 142 and the parameter sensor P.

[0235] During usage of the detection apparatus 100", upon the controller 225 determining that the signal readings are indicative of a substance 116 obstructing the passage of fluid 30 through the open port 136 of the distal tip 112, the controller 225 transmits a signal that changes dynamic pressure at the distal tip 112, 112'.

[0236] More particularly, in one exemplary embodiment, the controller 225 generates a signal causing a change in operation of the proximal body portion 210 that changes the dynamic pressure and causes dislodging of the substance 116 obstructing the passage of fluid 30 through the open port 136 of the distal tip 112. The signal transmitted by the controller 225 to the pump portion 142 changes discharge pressure or flow or both pressure and flow to the distal tip 112, 112' to dislodge the substance 116 at least partially obstructing the passage of fluid 30 through the open port of the distal tip 112, 112'.

[0237] In one exemplary embodiment, the operating steps for dislodging of a substance 116 obstructing the passage of fluid 30 through the open port of the distal tip 112, 112' include, during non-usage of the detection apparatus 100" to detect the presence of a substance 116 on a surface 31, 33, the controller 225 generating a signal causing a change in operation of the proximal body portion 210 that causes dislodging of the substance 116 at least partially obstructing the passage of fluid 30 through the open port of the distal tip 112, 112'. The change in operation of the proximal body portion 210 may be achieved by the pump portion 142 pumping a fluid through the distal probe portion 110 for a period of time necessary to minimize the probability of occurrence of a future blockage of the distal tip 116 or for a period of time necessary to dislodge the substance 116.

[0238] As defined herein, dislodging of substance 116 that may obstruct the passage of fluid 30 through the open port of the distal tip 112, 112' include minimizing the probability of occurrence of a future blockage of the distal tip 116. The period of time necessary to minimize the probability of occurrence of a future blockage of the distal tip 112 is for a period of time before usage of the detection apparatus 100" to detect the presence of a substance 116 on a surface 31, 33 or is for a period of time after usage of the detection apparatus 100" to detect the presence of a substance 116 on a surface 31, 33.

[0239] Similarly, the period of time necessary to dislodge a substance 116 obstructing the passage of fluid 30 through the open port of the distal tip 112, 112' may be for a period of time before usage of the detection apparatus 100" to detect the presence of a substance 116 on a surface 31, 33 or is for a period of time after usage of the detection apparatus 100" to detect the presence of a substance 116 on a surface 31, 33.

[0240] To implement the foregoing operating steps for dislodging of substance 116, referring to FIG. 10, the proximal body portion 210 may include a vibrating shaft 114 for vibrating bristles 262 that are disposed on distal oral insertion portion 250. As is well known in the art, the vibrating bristles 262 effect dental hygiene of a subject or of a user of the detection apparatus 100". The proximal body portion 210 may also include a bristle vibration motor 118 for operating the vibrating shaft 114 an activation device 144 for activating the bristle vibration motor 118 to operate the vibrating shaft 114. The activation device 144 is in electrical communication with the controller 225.

[0241] In one exemplary embodiment, the controller 225 transmits a signal to the pump portion 142 to cause passage of the second fluid 30 through the distal tip 112, 112' before activation of the activation device 144, the change in dynamic pressure being in comparison to the dynamic pressure before activation of the activation device 144. In another exemplary embodiment, the controller 225 transmits a signal to the pump portion 142 to cause passage of the second fluid 30 through the distal tip 112, 112' after activation of the activation device 144 and the controller 225 transmits a signal to the pump portion 142 to continue to cause passage of the second fluid 30 through the distal tip 112, 112' after de-activation of the activation device 144, the change in dynamic pressure being in comparison to the dynamic pressure after de-activation of the activation device 144.

[0242] In one exemplary embodiment, the proximal body portion 210 further includes a detection apparatus usage sensor 280 that is in electrical communication with the controller 225, and the time before activation of the activation device 144 is sensed by the controller 225 as being initiated by activation of the detection apparatus usage sensor 280. In exemplary embodiments, the detection apparatus usage sensor 280 is a motion sensor 282 or a contact sensor 284 or combinations thereof. The contactor sensor 284 may include a pressure sensor 284a or a temperature sensor 284b or combinations thereof.

[0243] In one exemplary embodiment, when the controller 225 senses activation of the detection apparatus usage sensor 280 without activation of the activation device 144 in a prescribed time period following receipt of a signal from the detection apparatus usage sensor 280, the controller 225

signals to the pump portion 142 to cease causing passage of the second fluid 30 through the distal tip 112, 112'.

[0244] Turning now to FIG. 25, there is illustrated another exemplary embodiment of a stream probe or detection apparatus for detecting the presence of a substance on a surface 100"a that includes a proximal body portion 210a that includes a central parameter sensing portion 120'a disposed in fluid communication between the pump portion 142 and the proximal probe portion 111. As with respect to stream probe 100" illustrated in FIG. 4C and FIG. 10, the central parameter sensing portion 120'a also enables fluid communication between the pump portion 142 and the proximal probe portion 111. Parameter sensor P is also disposed in fluid communication with the central parameter sensing portion 120'a.

[0245] However, stream probe or detection apparatus 100"a also includes fluid conduit member 402 in fluid communication with the proximal probe portion 111 and the central parameter sensing portion 120'a such that the fluid conduit member 402 forms a flow bypass around the parameter sensor P extending from a proximal or upstream junction 402a with the central parameter sensing portion 120'a to a distal or downstream junction 402b with the proximal probe portion 111. A fluid flow interrupting device 404, e.g., a flow control valve, is disposed in the fluid conduit member 402 and is maintained in a closed position during operation of the pump portion 142.

[0246] When the controller 225 receives a signal representing the sensing parameter, correlating to a substance 116 at least partially obstructing the passage of fluid 30 through the open port 136 of the distal tip 112, 112', the controller 225 transmits a signal to the fluid flow interrupting device 404 to at least partially open to bypass the parameter sensor P to increase dynamic pressure at the distal tip 112, 112' to dislodge the substance 116 at least partially obstructing the passage of fluid 30 through the open port 136 of the distal tip 112, 112'. When the controller 225 receives a signal from the parameter sensor P indicative of the pressure in the central parameter sensing portion 120'a has returned to a value indicating that the distal tip 112, 112' is in an unobstructed condition, the controller 225 may transmit a signal to the fluid flow interrupting device 404 to at least partially close.

[0247] FIG. 26 illustrates another exemplary embodiment of a stream probe or detection apparatus for detecting the presence of a substance on a surface 100"b that includes a proximal body portion 210b that, in a manner similar to stream probe 100' described above with respect to FIG. 4B, excludes the central parameter sensing portion and instead includes the pump portion 142 in direct fluid communication with proximal probe portion 111.

[0248] The proximal body portion 210b also includes parameter sensor P disposed in fluid communication with the proximal probe portion 111. In a similar manner as with respect to stream probe 100"a described above with respect to FIG. 25, a fluid conduit member 412 is in fluid communication with the proximal probe portion 111 such that the fluid conduit member 412 forms a flow bypass around the parameter sensor P extending from a proximal or upstream junction 412a with the proximal probe portion 111 to a distal or downstream junction 412b with the proximal probe portion 111 and a fluid flow interrupting device 414 is disposed in the fluid conduit member 412. The fluid flow

interrupting device **414** is in a closed position during operation of the pump portion **142**.

[0249] When the controller **225** receives a signal representing the sensing parameter, correlating to a substance **116** at least partially obstructing the passage of fluid **30** through the open port **136** of the distal tip **112**, **112'**, the controller **225** transmits a signal to the fluid flow interrupting device **414** to at least partially open to bypass the parameter sensor P to change dynamic pressure at the distal tip **112** to dislodge the substance **116** at least partially obstructing the passage of fluid **30** through the open port **136** of the distal tip **112**, **112'**. Similarly, when the controller **225** receives a signal from the parameter sensor P indicative of the pressure in the proximal probe portion **111** has returned to a value indicating that the distal tip **112**, **112'** is in an unobstructed condition, the controller **225** may transmit a signal to the fluid flow interrupting device **414** to at least partially close.

[0250] FIG. 27 illustrates another exemplary embodiment of a stream probe or detection apparatus **100''c** for detecting the presence of a substance on a surface that includes a proximal body portion **210c** that, in a manner similar to stream probe or detection apparatus **100''a** of FIG. 25, includes a central parameter sensing portion **120''b** enabling fluid communication between the pump portion **142** and the proximal probe portion **111**. Parameter sensor P is also disposed in fluid communication with the central parameter sensing portion **120''b**.

[0251] The proximal body portion **210c** includes an upstream fluid conduit member **420** extending from a proximal or upstream junction **430a** with the central parameter sensing portion **120''b** and a downstream fluid conduit member **424** extending to a distal or downstream junction **430b** with the central parameter sensing portion **120''b**. A fluid reservoir **422** is disposed between the proximal or upstream fluid conduit member **420** and the distal or downstream fluid conduit member **424** such that the fluid reservoir **422** is in fluid communication with the central parameter sensing portion **120''b**. A distal or downstream fluid flow interrupting device **428** is disposed in the distal or downstream fluid conduit member **424** and downstream of the fluid reservoir **422**.

[0252] A proximal or upstream fluid flow interrupting device **426** may be disposed in the proximal or upstream fluid conduit member **420** and upstream of the fluid reservoir **422**. The second fluid flow interrupting device **426** disposed upstream of the fluid reservoir **422** such that fluid communication is provided between a portion **120''b1** of the central parameter sensing portion **120''b** that is upstream of the parameter sensor P and a portion **120''b2** of the central parameter sensing portion **120''b** that is downstream of the parameter sensor P wherein the second fluid flow interrupting device **426**, the fluid reservoir **422** and the fluid flow interrupting device **428** form a flow by-pass around the parameter sensor P. The fluid reservoir **422** may be pressurized at a pressure above the pressure in the central parameter sensing portion **120''b2** downstream of the parameter sensor P when the fluid flow interrupting device **428** is in a closed position. Pressurization of the fluid reservoir **422** may be achieved by operating the pump portion **142** with the proximal or upstream fluid flow interrupting device **426** in the open position while the distal or downstream fluid conduit member **424** is in the closed position. Once the desired pressure in the fluid reservoir **422**, which may be measured by a parameter sensor P5 in fluid communication

with the fluid reservoir **422**, the proximal or upstream fluid interrupting device **426** may be closed to maintain pressurization of the fluid reservoir **422** until an operational demand for the fluid reservoir to increase pressure or flow into the central parameter sensing portion **120''b** occurs. The fluid reservoir **422** may also be pressurized via external means (not shown) as known to those skilled in the art.

[0253] When the controller **225** receives a signal representing the sensing parameter, correlating to a substance **116** at least partially obstructing the passage of fluid **30** through the open port **136** of the distal tip **112**, **112'**, the controller **225** transmits a signal to the fluid flow interrupting device **428** to at least partially open to release pressure from the fluid reservoir **422** to bypass the parameter sensor P thereby increasing dynamic pressure at the distal tip **112** to dislodge the substance **116** at least partially obstructing the passage of fluid **30** through the open port **136** of the distal tip **112**, **112'**.

[0254] During usage of the detection apparatus **100''c**, after the controller **225** has transmitted a signal to the fluid flow interrupting device **428** to at least partially open, when pressure in the fluid reservoir **422** has decreased, the controller **225** transmits a signal to the second fluid flow interrupting device **426** to transfer from a closed position to an at least partially open position to bypass flow around the parameter sensor P, thereby increasing dynamic pressure at the distal tip **112** to dislodge the substance **116** at least partially obstructing the passage of fluid **30** through the open port **136** of the distal tip **112**, **112'**.

[0255] FIG. 28 illustrates yet another exemplary embodiment of a stream probe or detection apparatus **100''d** for detecting the presence of a substance on a surface that includes a proximal body portion **210d** that includes first pump portion **142** as described above with respect to FIG. 4C and the central parameter sensing portion **120''a** disposed in fluid communication between the pump portion **142** and the proximal probe portion **111**. As before, the central parameter sensing portion **120** enables fluid communication between the pump portion **142** and the proximal probe portion **111**. The parameter sensor P is disposed in fluid communication with the central parameter sensing portion **120**.

[0256] Additionally, proximal body portion **210d** includes a second or stand-by pump portion **142'** having a pump discharge fluid conduit member **1202** in fluid communication with the central parameter sensing portion **120** through a connection **1200** in the central parameter sensing portion **120** downstream of the parameter sensor P. Proximal pump portion discharge flow path flow interruption device **168**, e.g., a check valve, is disposed in the pump discharge fluid conduit member **1202** at the discharge of stand-by pump portion **142'**.

[0257] When the controller **225** receives a signal representing the sensing parameter, correlating to a substance **116** at least partially obstructing the passage of fluid **30** through the open port **136** of the distal tip **112**, **112'**, the controller **225** transmits a signal to the stand-by pump portion **142'** to initiate operation thereby increasing dynamic pressure at the distal tip **112** to dislodge the substance **116** at least partially obstructing the passage of fluid **30** through the open port **136** of the distal tip **112**, **112'**.

[0258] FIG. 29 illustrates still another exemplary embodiment of a stream probe or detection apparatus **100''e** for detecting the presence of a substance on a surface that includes a proximal body portion **210e** that includes first

pump portion 142 as described above with respect to FIG. 4C. However, in contrast to FIG. 4C, the pump portion 142 now comprises a suction intake 162' enabling suction of the second fluid 30 through the pump portion 142 and enabling suction of a third fluid 36 through the pump portion 142. Suction intake 162' may be a tee connection as shown having a base 162'' with a first inlet 162'a and a second inlet 162'b. Suction intake 162' further includes tap 162'c forming a tee outlet in fluid communication with first inlet 162'a and the second inlet 162'b. First inlet 162'a is disposed in fluid communication with suction flow interruption device 164 on the suction intake of pump portion 142. Thus, connection of the tap or tee outlet 162'c with suction flow interrupting device 164 enables fluid communication between air from the ambient environment at first tee inlet 162'a and the pump portion 142. Suction intake filter 166 is now disposed in the first tee inlet 162'a. A suction intake air flow interruption device 165, e.g., a flow control valve, may be disposed proximally or upstream of the first tee inlet 162'a to control the flow of air 30, indicated by arrow A from the ambient environment through the first tee inlet 162'a.

[0259] The proximal body portion 210e may further include a third fluid supply member 176 that is in fluid communication with the distal probe portion 110 through the second tee inlet 162'b, the proximal pump portion 142 and the central parameter sensing portion 120'. Fluid 36 is supplied to the pump portion 142 through the third fluid supply member 176 via a fluid storage tank 170 that is in fluid communication with the third fluid supply member 176 via a fluid storage tank discharge member 172 and a flow interrupting device 174 that may include a fluid control valve.

[0260] Accordingly, the change in dynamic pressure includes operating the pump portion 142 to cause passage of the third fluid 36 to the distal tip 112, 112' to dislodge a substance 116 obstructing the passage of fluid 30 through the open port 136 of the distal tip 112, 112'. In one exemplary embodiment, the third fluid 36 is a liquid. In a further exemplary embodiment, the liquid may be a disinfectant such as mouth wash fluid or alcohol, etc.

[0261] The third fluid 36 may be a liquid droplet 36' and the pump portion 142 suctions through the suction intake 152 concurrently the second fluid 30 and the liquid droplet 36' causing passage of the second fluid 30 and the liquid droplet to the distal tip 112, 112'. The pump portion 142 may be designed and operated such that the pump portion 142 imparts sufficient kinetic energy to the liquid droplet 36' such that passage of the liquid droplet 36' to the distal tip 112, 112' causes dislodging of a substance 116 obstructing the passage of the second fluid 30 through the open port of the distal tip 112, 112'. During this operation of the pump portion 142 drawing third liquid 36 and second fluid 30 or liquid droplet 36' and second fluid 30 to distal tip 112, 112', the stream probe or detection apparatus 100''e may be stored on a docking station 180 which may also function as an electrical charging station for the power supply 270.

[0262] FIG. 30 illustrates yet another exemplary embodiment of a stream probe or detection apparatus for detecting the presence of a substance on a surface wherein, referring to, for example, FIG. 4C and FIG. 10, the distal oral insertion portion 250 is detached from the proximal body portion 210 at the connector 230 and positioned in a detection apparatus sanitizing unit 500 that includes a sanitizing fluid storage reservoir or basin 510 that contains a ramming

fluid such as third fluid 36 described above with respect to FIG. 29 wherein the third fluid 36 is a liquid, and again, in a further exemplary embodiment, the liquid may be a disinfectant such as mouth wash fluid or alcohol, etc.

[0263] The detection apparatus sanitizing unit 500 includes a distal oral insertion portion mounting member 520 which receives the distal oral insertion portion 250 such that the distal oral insertion portion 250 is positioned in the sanitizing fluid storage reservoir or basin 510 to enable immersion of the distal oral insertion portion 250 in the fluid 36.

[0264] The mounting member 520 is further configured to receive a multiple connection member 530 such as a tee connection that includes a header 532 having a tap or outlet connection 531 that removably attaches to the proximal end 260 of the distal oral insertion portion 250 via the connector 230 (see FIG. 10). A first header connection 532a is configured such that fluid 36 may be injected through the distal tip 112, 112' of the distal probe portion 110 of the distal oral insertion portion 250. The first header connection 532a is in fluid communication with a fluid supply pump 536a that discharges fluid 36 through a fluid supply pump discharge flow control valve 534a. The fluid 36 is suctioned through the suction intake of the fluid supply pump 536a as indicated by arrow 502a thereby providing fluid communication between the fluid supply pump 536a and the distal tip 112, 112'. The change in dynamic pressure includes the fluid supply pump 536a being operated for a sufficient time to inject third fluid 36 to dislodge a substance 116 obstructing the passage of the second fluid 30 through the open port of the distal tip 112, 112' or to sanitize the distal oral insertion portion 250.

[0265] In one exemplary embodiment, upon completion of the operation of the fluid supply pump 536a to dislodge the substance 116 or to sanitize the distal oral insertion portion 250, second header connection 532b is configured such that drying fluid 11' may be injected through the distal tip 112, 112' of the distal probe portion 110 of the distal oral insertion portion 250. The second header connection 532b is in fluid communication with a drying fluid supply compressor 536b that discharges drying fluid 11' through a drying fluid supply compressor discharge flow control valve 534b. The drying fluid 11' is suctioned through the suction intake of the drying fluid supply compressor 536b as indicated by arrow 502b thereby providing fluid communication between the drying fluid supply compressor 536b and the distal tip 112, 112'. The drying fluid supply compressor 536b may be operated for a period of time sufficient to accomplish the desired objective of drying or further sanitizing the distal oral insertion portion 250. In one exemplary embodiment, the drying fluid 11' is ambient air either at ambient temperature or heated above ambient temperature. The drying fluid 11' may also include a gas such as carbon dioxide or a medical sterilization gas such as ethylene oxide.

[0266] In one exemplary embodiment, FIG. 31 illustrates one exemplary embodiment of yet another method of dislodging a substance 116 obstructing the passage of the second fluid 30 through the open port of the distal tip 112, 112'. More particularly, in FIG. 31, stream probe 100 described above with respect to FIG. 4A and FIG. 10 is illustrated wherein the distal oral insertion portion 250 is immersed in a liquid reservoir 510' that is similar to the sanitizing fluid storage reservoir or basin 510. As before with respect to FIG. 4A, the proximal body portion 210

includes the controller 225 which controls operation of the pump portion 124 such that at least one alternating cycle of operation of the pump portion 124 causes a negative pressure condition, or under pressure condition, and a positive pressure condition at the distal tip 112, 112' thereby oscillating fluid flow through the distal tip 112, 112'. The oscillating fluid flow and oscillation between the negative pressure condition and the positive pressure condition changes the dynamic pressure at the distal tip 112, 112' to dislodge a substance 116 that may be obstructing the passage of the second fluid 30 through the open port of the distal tip 112, 112' or sanitizes the distal oral insertion portion 250 or both dislodges the substance 116 and sanitizes the distal oral insertion portion 250.

[0267] FIG. 32 illustrates a user 600 of the stream probe 100 of FIG. 31 wherein the negative pressure condition or under pressure condition is achieved by the distal oral insertion portion 250 being inserted into the mouth 602 of a user 600 and immersed in a liquid 604 that is the liquid in the mouth 602 of the user 600. More particularly, the liquid 604 may be mouth wash and may include a sanitizing or disinfecting component. Again, as described with respect to FIG. 31, in relation to FIG. 4A, the proximal body portion 210 includes the controller 225 which controls operation of the pump portion 124 such that at least one alternating cycle of operation of the pump portion 124 causes a negative pressure condition, or under pressure condition, and a positive pressure condition at the distal tip 112, 112' thereby oscillating fluid flow through the distal tip 112, 112'. The oscillating fluid flow and oscillation between the negative pressure condition and the positive pressure condition changes the dynamic pressure at the distal tip (112, 112') to dislodge a substance 116 that may be obstructing the passage of the second fluid 30 through the open port of the distal tip 112, 112' or sanitizes the distal oral insertion portion 250 or both dislodges the substance 116 and sanitizes the distal oral insertion portion 250.

[0268] Those skilled in the art will recognize that, and understand how, the various embodiments of the present disclosure as described in FIGS. 25-32 and in relationship to FIGS. 1-24 may be used individually or in combination with one or more of the other embodiments of the present disclosure.

[0269] While several embodiments of the disclosure have been shown in the drawings, it is not intended that the disclosure be limited thereto, as it is intended that the disclosure be as broad in scope as the art will allow and that the specification be read likewise. Therefore, the above description should not be construed as limiting, but merely as exemplifications of particular embodiments. Those skilled in the art will envision other modifications within the scope of the claims appended hereto.

[0270] In the claims, any reference signs placed between parentheses shall not be construed as limiting the claim. The word "comprising" does not exclude the presence of elements or steps other than those listed in a claim. The word "a" or "an" preceding an element does not exclude the presence of a plurality of such elements. The word "or" does not exclude the presence of more than one or all of the alternatives in a listing of alternatives. The invention may be implemented by means of hardware comprising several distinct elements, and/or by means of a suitably programmed processor. In the device claim enumerating several means, several of these means may be embodied by one and

the same item of hardware. The mere fact that certain measures are recited in mutually different dependent claims does not indicate that a combination of these measures cannot be used to advantage.

1. An oral stream probe detection apparatus for detecting the presence of a substance on a dental surface, comprising:
 a distal probe portion in an oral insertion portion configured to be immersed in a first fluid, the distal probe portion defining a distal tip having an open port to enable the passage of a second fluid therethrough; and
 a proximal body portion that comprises (i) a pump portion, (ii) a proximal probe portion in fluid communication with the pump portion, wherein the proximal probe portion can be connected via a connector to the distal probe portion to establish fluid communication between the proximal probe portion and the distal probe portion,

wherein the pump portion causes passage of the second fluid through the distal tip inducing thereby a change in a sensing parameter in the distal probe portion for enabling detection of the substance that may be present on the dental surface based on measurement of a signal representing the sensing parameter, correlating to the substance on the dental surface at least partially obstructing the passage of the second fluid through the open port of the distal tip, (iii) a parameter sensor configured and disposed to detect the signal representing the sensing parameter; and

(iv) a controller for processing signal readings sensed by the parameter sensor and for determining whether the signal readings are indicative of the substance at least partially obstructing the passage of second fluid through the open port of the distal tip, the controller in electrical communication with the pump portion and the parameter sensor, the controller transmitting an electrical communication to at least the pump portion for effecting changes in dynamic pressure at the distal tip in response to determining that the processed signal readings are indicative of the substance at least partially obstructing the passage of second fluid through the open port of the distal tip,

pump portion causing a change in dynamic pressure for dislodging of the substance through the open port of the distal tip via a flow bypass around the parameter sensor.

2. (canceled)

3. The detection apparatus according to claim 1,

wherein the proximal body portion further comprises: (v) the parameter sensor disposed in fluid communication with the proximal probe portion, (vi) a fluid conduit member in fluid communication with the proximal probe portion such that the fluid conduit member forms a flow bypass around the parameter sensor, and (vii) a fluid flow interrupting device disposed in the fluid conduit member, the fluid flow interrupting device in a closed position during operation of the pump portion, wherein responsive to the controller receiving a signal representing the sensing parameter that correlates to a substance at least partially obstructing the passage of fluid through the open port of the distal tip, the controller transmits a signal to the fluid flow interrupting device to at least partially open to bypass the parameter sensor to change dynamic pressure at the distal tip to dislodge the substance at least partially obstructing the passage of fluid through the open port of the distal tip.

4. The detection apparatus according to claim 1, wherein the proximal body portion further comprises (v) a central parameter sensing portion disposed in fluid communication between the pump portion and the proximal probe portion, the central parameter sensing portion enabling fluid communication between the pump portion and the proximal probe portion, (vi) the parameter sensor disposed in fluid communication with the central parameter sensing portion, (vii) a fluid conduit member in fluid communication with the proximal probe portion and the central parameter sensing portion such that the fluid conduit member forms a flow bypass around the parameter sensor, and (viii) a fluid flow interrupting device disposed in the fluid conduit member, the fluid flow interrupting device in a closed position during operation of the pump portion, wherein responsive to the controller receiving a signal representing the sensing parameter that correlates to a substance at least partially obstructing the passage of fluid through the open port of the distal tip, the controller transmits a signal to the fluid flow interrupting device to at least partially open to bypass the parameter sensor to change dynamic pressure at the distal tip to dislodge the substance at least partially obstructing the passage of fluid through the open port of the distal tip.
5. The detection apparatus according to claim 4, wherein the fluid conduit member further comprises a fluid reservoir disposed upstream of the fluid flow interrupting device and in fluid communication with the central parameter sensing portion, wherein the fluid reservoir is pressurized at a pressure above the pressure in the central parameter sensing portion downstream of the parameter sensor when the fluid flow interrupting device is in a closed position.
6. The detection apparatus according to claim 5, wherein responsive to the controller receiving a signal representing the sensing parameter that correlates to a substance at least partially obstructing the passage of fluid through the open port of the distal tip, the controller transmits a signal to the fluid flow interrupting device to at least partially open to release pressure from the fluid reservoir to bypass the parameter sensor thereby increasing dynamic pressure at the distal tip to dislodge the substance at least partially obstructing the passage of fluid through the open port of the distal tip.
7. The detection apparatus according to claim 6, further comprising:
a second fluid flow interrupting device disposed upstream of the fluid reservoir such that fluid communication is provided between a portion of the central parameter sensing portion that is upstream of the parameter sensor and a portion of the central parameter sensing portion that is downstream of the parameter sensor wherein the second fluid flow interrupting device, the fluid reservoir and the fluid flow interrupting device form a flow by-pass around the parameter sensor.
8. The detection apparatus according to claim 7, after the controller has transmitted a signal to the fluid flow interrupting device to at least partially open and responsive to pressure in the fluid reservoir decreasing, the controller transmits a signal to the second fluid flow interrupting device to transfer from a closed position to an at least partially open position to bypass flow around the parameter sensor, thereby increasing dynamic pressure at the distal tip to dislodge the substance at least partially obstructing the passage of fluid through the open port of the distal tip.
9. The detection apparatus according to claim 4 further comprising,
(vii) a stand-by pump portion having a pump discharge fluid conduit member in fluid communication with the central parameter sensing portion through a connection **1200** in the central parameter sensing portion downstream of the parameter sensor, wherein responsive to the controller receiving a signal representing the sensing parameter that correlates to a substance at least partially obstructing the passage of fluid through the open port of the distal tip, the controller transmits a signal to the stand-by pump portion to initiate operation thereby increasing dynamic pressure at the distal tip to dislodge the substance at least partially obstructing the passage of fluid through the open port of the distal tip.
10. (canceled)
11. The detection apparatus according to claim 1, further comprising:
an activation device in electrical communication with the controller for activating a bristle vibration motor to operate a vibrating shaft for vibrating bristles disposed on the oral insertion portion of the detection apparatus, the vibrating bristles for effecting dental hygiene of the dental surface.
12. The detection apparatus according to claim 11, further comprising a detection apparatus usage sensor in electrical communication with the controller, the detection apparatus usage sensor being at least one of a motion sensor or a contact sensor, the contactor sensor being at least one of a pressure sensor or a temperature sensor.
13. (canceled)
14. The detection apparatus according to claim 12, wherein responsive to the controller sensing activation of the detection apparatus usage sensor without activation of the activation device within a prescribed time period, the controller signals the pump portion to cease passage of the second fluid through the distal tip.
15. The detection apparatus according to claim 1, wherein the pump portion further comprises a suction intake enabling suction of the second fluid through the pump portion and enabling suction of a third fluid through the pump portion, wherein effecting changes in dynamic pressure further includes the pump portion causing passage of the third fluid to the distal tip to dislodge the substance obstructing the passage of fluid through the open port of the distal tip.

* * * * *

专利名称(译)	减少斑块检测流探针的阻塞		
公开(公告)号	US20160338635A1	公开(公告)日	2016-11-24
申请号	US15/114558	申请日	2015-01-21
[标]申请(专利权)人(译)	皇家飞利浦电子股份有限公司		
申请(专利权)人(译)	皇家飞利浦N.V.		
当前申请(专利权)人(译)	皇家飞利浦N.V.		
[标]发明人	JOHNSON MARK THOMAS SPRUIT JOHANNES HENDRIKUS MARIA PRINS MENNO WILLEM JOSE DEANE STEVEN CHARLES HORSTMAN PIETER VAN GOOL EDGAR MARTINUS OUWELTJES OKKE		
发明人	JOHNSON, MARK THOMAS SPRUIT, JOHANNES HENDRIKUS MARIA PRINS, MENNO WILLEM JOSE DEANE, STEVEN CHARLES HORSTMAN, PIETER VAN GOOL, EDGAR MARTINUS OUWELTJES, OKKE		
IPC分类号	A61B5/00 A61C17/22 A61C17/20 A61C17/02 A61C1/00		
CPC分类号	A61B5/4547 A61C17/0202 A61C17/221 A61C17/20 A61C1/0015		
优先权	2014153279 2014-01-30 EP		
外部链接	Espacenet USPTO		

摘要(译)

用于检测表面上物质的存在的检测装置的近端主体部分 (210) 包括泵部分 (142) 和近端探针部分 (210) 。 b> 111,120 彼此流体连通。控制器 (225) 处理由参数传感器 (P, P 1 或 P 2) 检测到的信号读数, 并确定信号读数是否为指示物质 (116) 阻碍液体通过 (130) 通过远端尖端的开口 (112,112') 检测装置的远端探针部分 (110) (100,100', 100", 100" a 100" b, 100" c, 100" d, 100 C 的)。控制器 (225) 在确定信号读数指示物质时 () 发送改变远端尖端动态压力的信号 (112,112') 。 > 116 阻止流体 (130) 通过远端尖端的开口 (112') 。

