



US 20160045164A1

(19) **United States**

(12) **Patent Application Publication**
TIENSUU

(10) **Pub. No.: US 2016/0045164 A1**

(43) **Pub. Date: Feb. 18, 2016**

(54) **SENSOR GUIDE WIRE ASSEMBLY WITH
BUTTON-CELL TYPE BATTERY**

(52) **U.S. Cl.**

CPC *A61B 5/6851* (2013.01); *H04B 13/005*
(2013.01); *A61B 5/07* (2013.01); *A61B 5/0215*
(2013.01); *A61B 5/01* (2013.01); *A61B 5/026*
(2013.01)

(71) Applicant: **ST. JUDE MEDICAL SYSTEMS AB,**
Uppsala (SE)

(72) Inventor: **Stefan TIENSUU,** Uppsala (SE)

(73) Assignee: **ST. JUDE MEDICAL SYSTEMS AB,**
Uppsala (SE)

(57)

ABSTRACT

A sensor guide wire assembly having a button-cell type battery includes a transmitter unit configured to be connected to a sensor guide wire that is insertable into a patient to measure a parameter, the transmitter unit being configured to wirelessly transfer data representing the measured parameter to a communication unit. The transmitter unit includes a housing, a printed circuit board holder disposed in the housing, and a printed circuit board disposed in the housing and held by the printed circuit board holder. The printed circuit board includes a plurality of electrical contacts. A slider is slidable from a location outside the housing, the slider including a protrusion extending into an area inside the housing. A space within the housing is configured to hold one or more batteries. The slider is slidable from a first position, at which a micro-switch is not activated, to a second position, at which the micro-switch is activated by the protrusion of the slider, which allows power to be provided to the printed circuit board.

(21) Appl. No.: **14/458,400**

(22) Filed: **Aug. 13, 2014**

Publication Classification

(51) **Int. Cl.**

A61B 5/00 (2006.01)
A61B 5/026 (2006.01)
A61B 5/0215 (2006.01)
A61B 5/01 (2006.01)
H04B 13/00 (2006.01)
A61B 5/07 (2006.01)

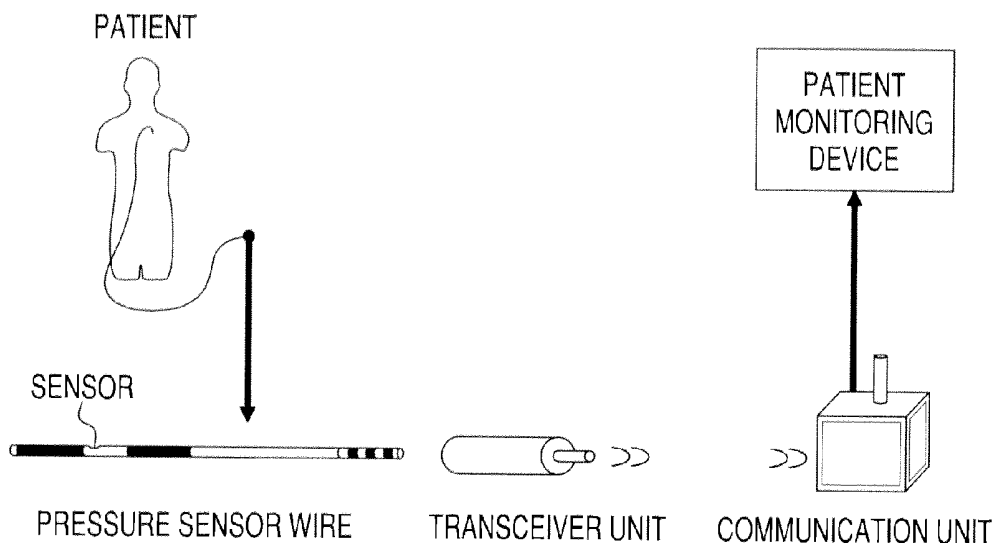

FIG. 1

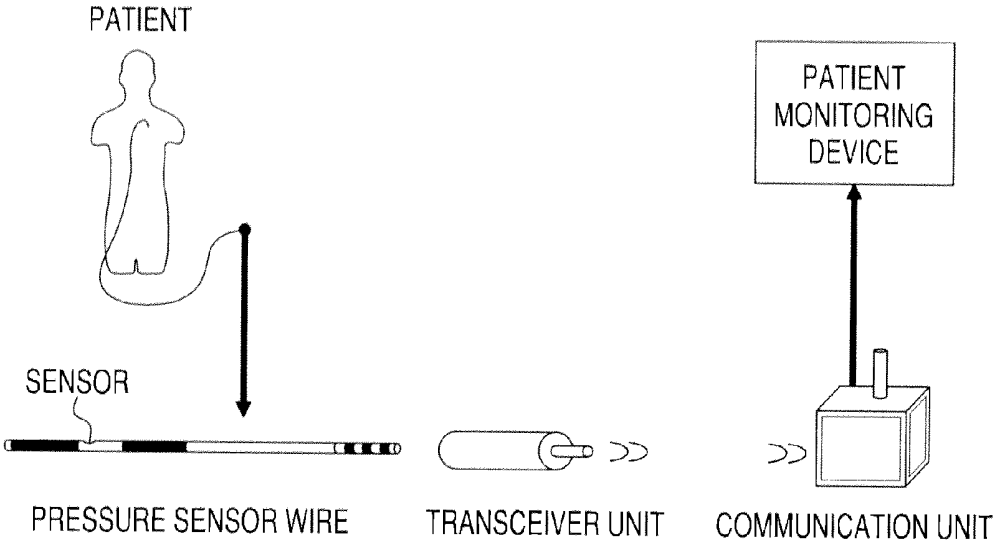

FIG. 2A

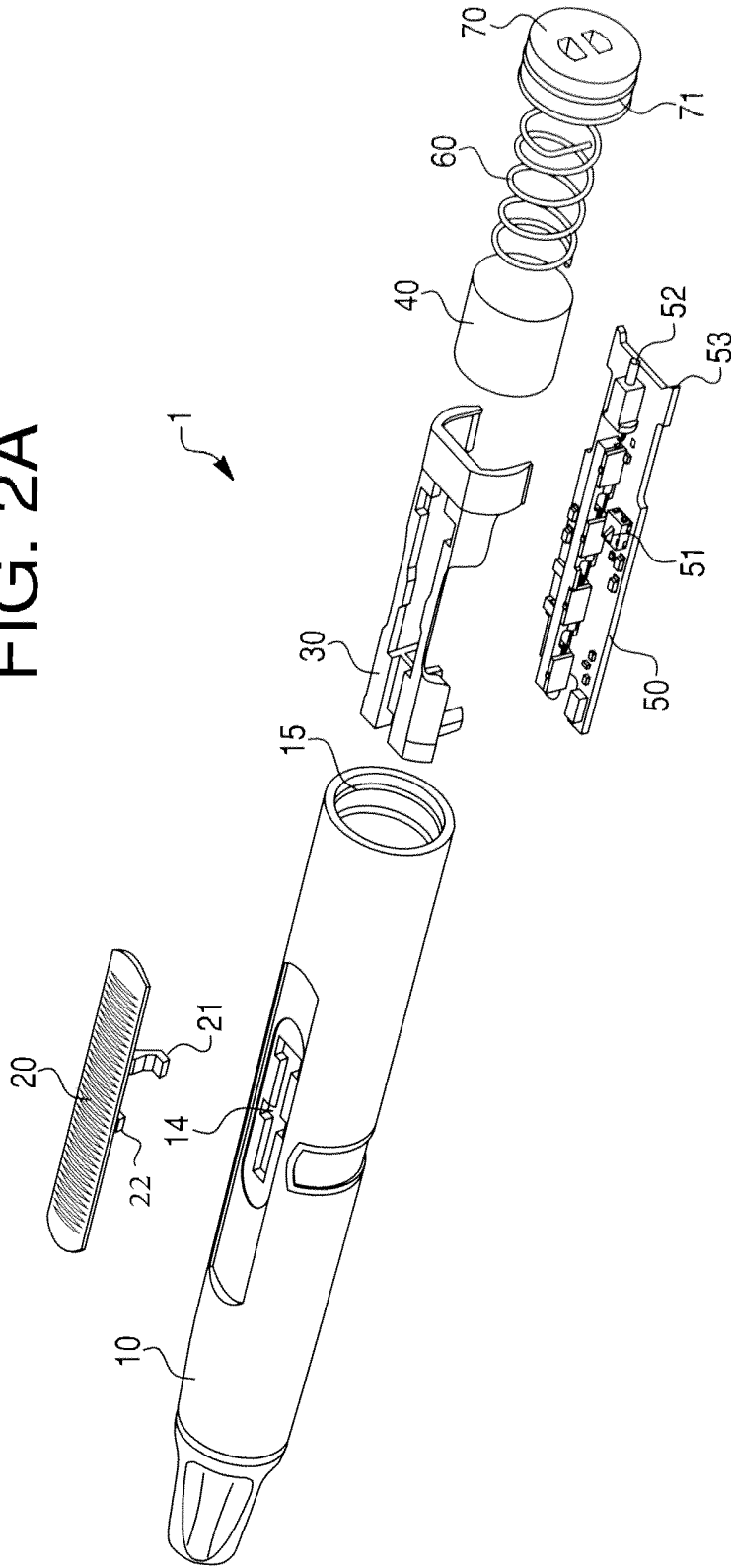

FIG. 2B

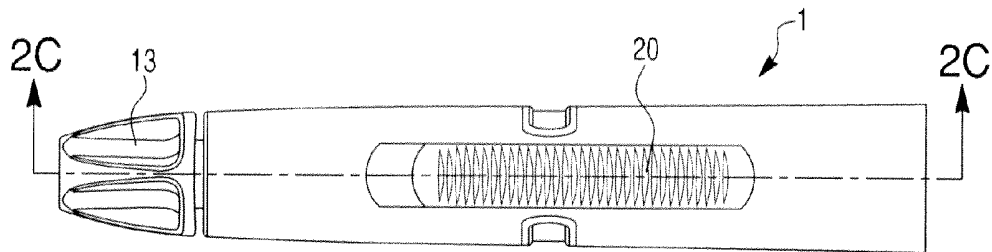

FIG. 2C

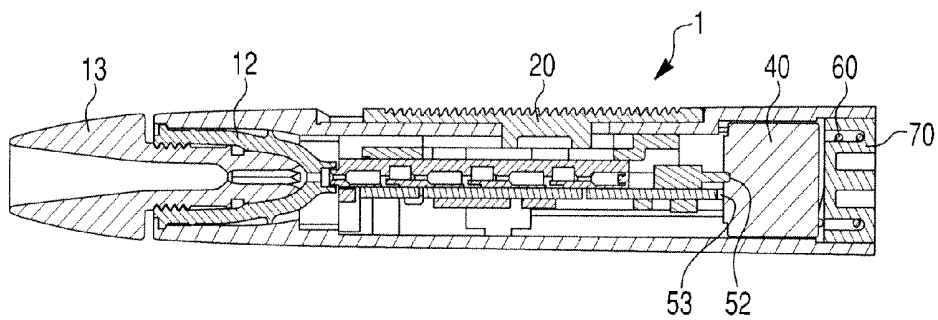

FIG. 3

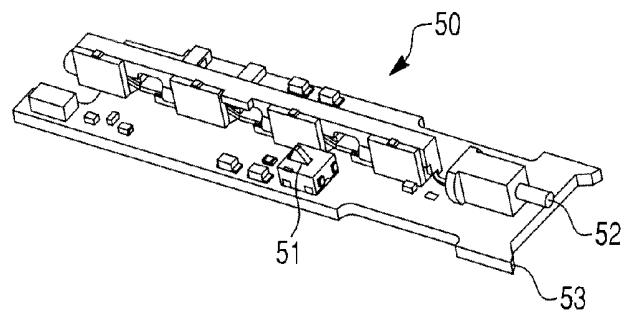

FIG. 4A

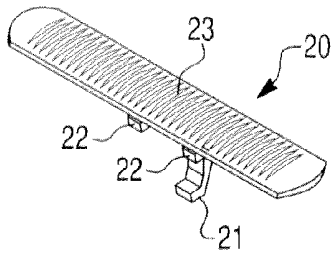

FIG. 4D

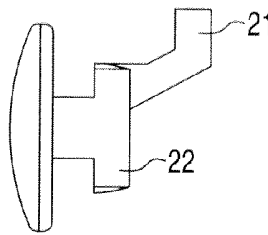

FIG. 4E

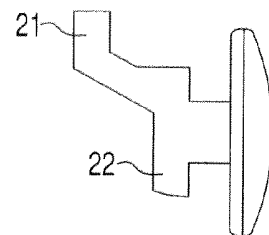

FIG. 4B

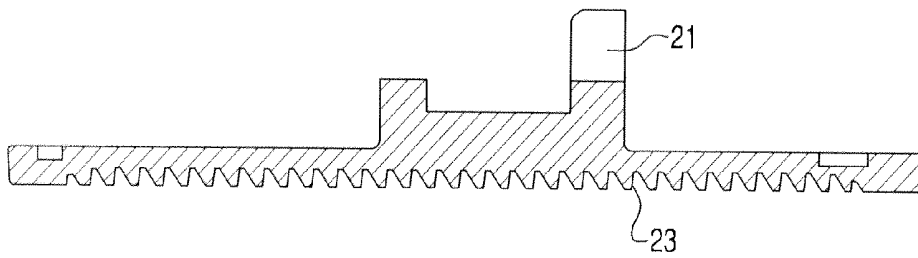

FIG. 4C

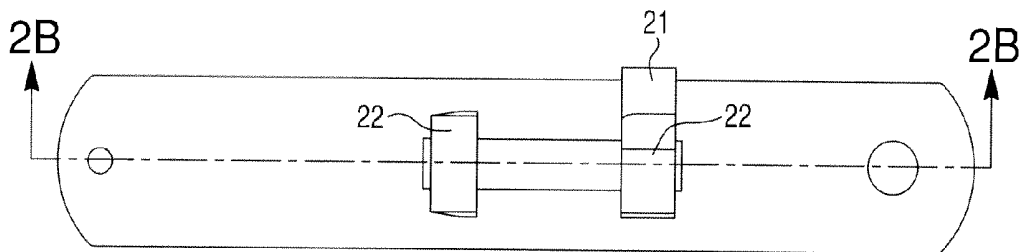

FIG. 5

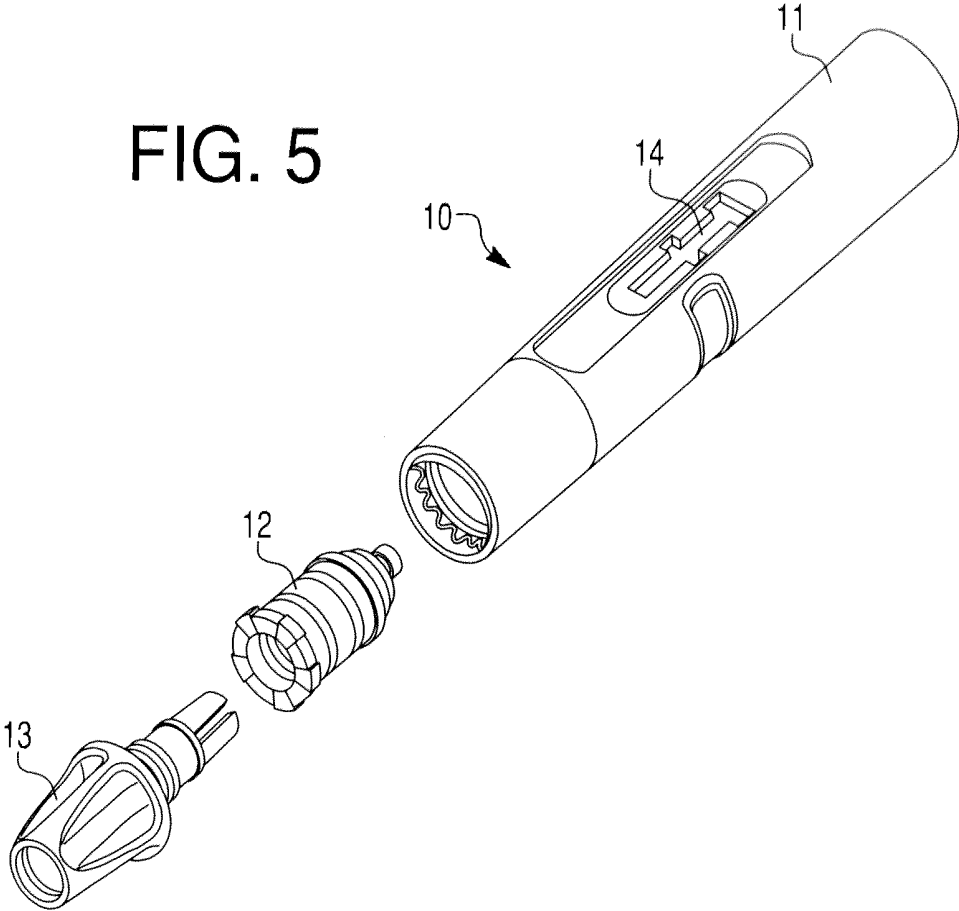

FIG. 6A

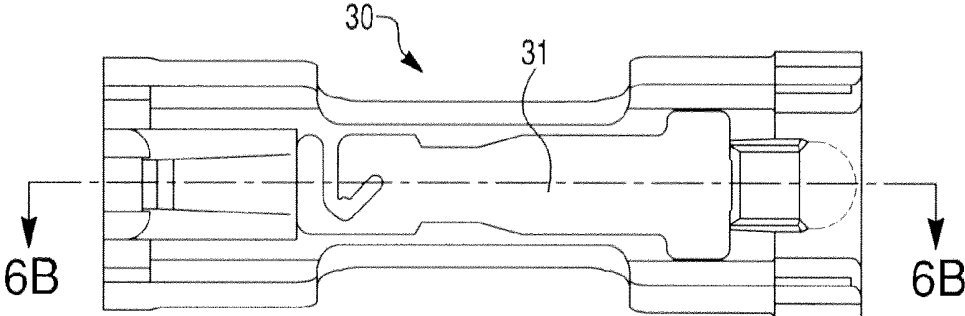
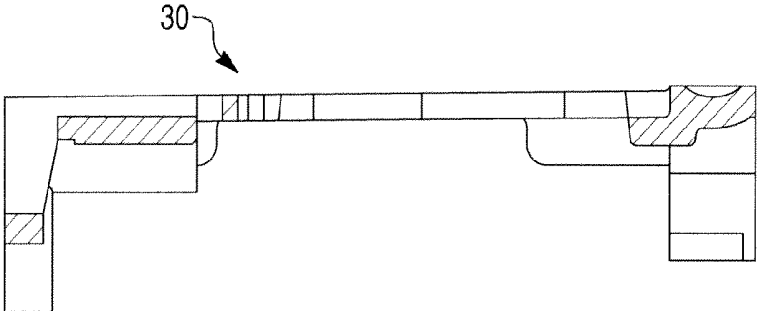

FIG. 6B



**SENSOR GUIDE WIRE ASSEMBLY WITH
BUTTON-CELL TYPE BATTERY****BACKGROUND**

[0001] The present disclosure relates generally to a sensor guide wire assembly and, in particular, to a sensor guide wire assembly having a button-cell type battery.

[0002] In many medical procedures, various physiological parameters within the body of a patient are monitored and analyzed. Typically, these parameters are physical in nature—such as pressure, temperature, and flow rate. These parameters are preferably monitored in a safe, reliable and accurate way. For example, a sensor may be mounted on a guide wire and positioned via the guide wire in a blood vessel in a living body to detect a physiological parameter. The sensor includes elements that are directly or indirectly sensitive to the parameter. For example, temperature can be measured by observing the resistance of a conductor having temperature sensitive resistance, as described in U.S. Pat. No. 6,615,067. Another exemplifying sensor may be found in U.S. Pat. No. 6,167,763, in which blood exerts pressure on the sensor which delivers a signal representative of the exerted pressure.

[0003] A raw signal generated by the sensor located within the body is transmitted to an external device, in which the signal is translated into physiological data. This data is processed and the results may be continuously saved and/or displayed on, for example, a monitor. In order to power the sensor and communicate signals representing the measured physiological variable to an external device, one or more cables or leads for transmitting the signals are connected to the sensor, and are routed along the guide wire, out from the vessel, and to the external device, conventionally via physical cables. In addition, the guide wire is typically provided with a central metal wire (i.e., a “core wire”) serving as a support for the sensor and, optionally, also as an electrical connection to the sensor, and a surrounding tubing. Hence, a sensor guide wire typically comprises a core wire, leads, and a protective tubing, as well as a distal coil or tube and a jacket housing the sensor.

[0004] In order to reduce the risks of having an electrically conductive device such as a pressure transducer connected both to a patient and to an electronic monitoring instrument, a wireless arrangement can be used, as described, for example, in US Patent Application Publication No. 2006/0009817. In this publication, the pressure sensor guide wire is configured to be connected, at its proximal end, to a transmitter unit. The transmitter unit is configured to wirelessly communicate via a communication signal with a communication unit that is connected to the external device, in order to transfer measured pressure data to the external device. In addition to the advantage of electrical insulation, a wireless arrangement decreases the amount of cables and other electrical equipment present in an operating room, and also facilitates the use of a standardized communication unit capable of being connected to a wide range of external devices. This obviates the necessity to use a specific external device, possibly different from that which is already present in the operating room. However, in contrast to a conventional sensor guide wire assembly, the pressure sensor in a wireless arrangement is not in electrical connection with the external device. Therefore, an additional energy source is required, such as a battery or capacitor, to power the transmitter unit and the pressure sensor.

SUMMARY

[0005] U.S. Patent Publication No. 2009/0124880 describes a sensor guide wire assembly having a detachable energy source (e.g., a battery pack or battery holder). While this assembly provides benefits over previous assemblies, the use of a separate battery pack or battery holder can increase the size and/or complexity of the assembly, and can require additional sterilization of the battery pack or battery holder. Thus, there is a need for improved sensor guide wire assemblies that allow for wireless transmission of sensor data.

[0006] The entire contents of the patents and publications cited in this disclosure are incorporated herein by reference for the devices and methods disclosed therein related to measurement.

[0007] In one embodiment, a device comprises a transmitter unit configured to be connected to a sensor guide wire that is insertable into a patient to measure a physiological or other parameter, the transmitter unit being configured to wirelessly transfer data representing the measured physiological parameter to a communication unit, and the transmitter unit comprising: a housing, a printed circuit board holder disposed in the housing, a printed circuit board disposed in the housing and held by the printed circuit board holder, the printed circuit board comprising a plurality of electrical contacts, a slider that is slidable from a location outside the housing, the slider including a protrusion extending into an area inside the housing, and a space within the housing, the space being configured to hold one or more batteries. The slider is slidable from a first position, at which a micro-switch is not activated, to a second position, at which the micro-switch is activated by the protrusion of the slider, which allows power to be provided to the printed circuit board.

[0008] In one aspect, the space within the housing is configured to hold one or more button-cell type batteries.

[0009] In one aspect, the housing comprises at least one member configured to secure the sensor guide wire to the housing.

[0010] In one aspect, the device further comprises an end cap configured to secure the one or more batteries inside of the housing.

[0011] In one aspect, the device further comprises a spring located between the one or more batteries and the end cap to promote contact between the one or more batteries and at least one of the electrical contacts on the printed circuit board.

[0012] In one aspect, the end cap is attached by threads, screws, snaps, or barbs.

[0013] In one aspect, the outer surface of the slider is ribbed.

[0014] In one aspect, the physiological parameter is pressure, temperature, or flow.

[0015] In one aspect, the device further comprises a receiver module to form a transceiver unit.

[0016] In one aspect, the device further comprises a sensor guide wire configured to be inserted into a patient to measure a physiological parameter.

[0017] In one aspect, the transmitter unit is adapted to communicate by a radio frequency signal with a communication unit, arranged in connection with an external device.

[0018] In one aspect, the protrusion is offset from the center of the slider.

[0019] In one aspect, the housing has an opening through which the protrusion extends.

[0020] In one aspect, the printed circuit board holder has an opening through which the protrusion extends.

[0021] In one aspect, the micro-switch is activated by the protrusion being slid over the micro-switch to a position past the micro-switch.

[0022] In one aspect, the micro-switch is activated by the protrusion being slid to a position above the micro-switch.

[0023] In one aspect, the space within the housing is configured to hold one or more batteries in a position where the longitudinal axis of the one or more batteries is aligned with the longitudinal axis of the housing.

[0024] In one aspect, the space within the housing configured to hold one or more batteries is located between the printed circuit board and the end cap.

BRIEF DESCRIPTION OF DRAWINGS

[0025] FIG. 1 depicts a system in which a transmitter unit according to embodiments of the present invention can be used.

[0026] FIG. 2A is a side exploded perspective view of transmitter unit according to one embodiment of the present invention.

[0027] FIG. 2B is a top view of the transmitter unit shown in FIG. 2A.

[0028] FIG. 2C is a side, cross-sectional view of the transmitter unit shown in FIG. 2A.

[0029] FIG. 3 is a top, side perspective view of a printed circuit board assembly that is included in the transmitter unit of FIG. 2A, according to one embodiment of the invention.

[0030] FIG. 4A is a top, side perspective view of a slider of the transmitter unit of FIG. 2A, according to one embodiment of the invention.

[0031] FIG. 4B is a side, cross-sectional view of the slider shown in FIG. 4A.

[0032] FIG. 4C is a bottom view of the slider shown in FIG. 4A.

[0033] FIG. 4D is a left side view of the slider shown in FIG. 4A.

[0034] FIG. 4E is a right side view of the slider shown in FIG. 4A.

[0035] FIG. 5 is a side perspective exploded view of a housing of the transmitter unit of FIG. 2A, according to one embodiment of the invention.

[0036] FIG. 6A is a top view of a printed circuit board holder that is included in the transmitter unit of FIG. 2A, according to one embodiment of the invention.

[0037] FIG. 6B is a side view of the printed circuit board holder shown in FIG. 6A.

DETAILED DESCRIPTION

[0038] In the following description, for purposes of explanation and not limitation, details and descriptions are set forth in order to provide a thorough understanding of embodiments of the present invention. However, it will be apparent to those skilled in the art that the present invention may be practiced in other embodiments that depart from these details and descriptions.

[0039] FIG. 1 depicts a system in which a transmitter unit according to embodiments of the present invention can be used. The system includes a sensor guide wire or pressure sensor wire with a sensor adapted to measure a physiological parameter (e.g., pressure, temperature, or flow) or other parameter inside a patient, and to provide data representing the measured parameter to an external device. The sensor is located at a distal end portion of the sensor guide wire and at

least one conductor is configured to conduct an electrical sensor signal from the sensor at the distal end portion of the sensor guide wire to a proximal end portion of the sensor guide wire. The sensor guide wire is adapted to be connected, at its proximal end, to a transmitter unit adapted to wirelessly communicate via a radio frequency signal with a communication unit arranged in connection with an external device, in order to transfer data representing the measured parameter to the external device for analysis and/or display. The data is communicated by the transceiver unit and transferred as a data stream to the communication unit at a prescribed frequency range (in the case where the communication signal is a radio frequency signal). The signal can also be an infrared signal, a light signal, an ultrasound signal or any wirelessly transmitted signal. Preferably, the transmitter unit comprises a sensor signal adapting circuitry and a communication module, connected to the sensor signal adapting circuitry, configured to handle the wireless communication with the communication unit via an antenna.

[0040] The external device may be a dedicated device or a patient monitoring device, preferably provided with a monitor, or a PC provided with relevant software and external connections to receive and to process the received data.

[0041] FIGS. 2A-2C show the transmitter unit 1 according to one embodiment of the present invention. As shown in FIG. 2A the transmitter unit 1 comprises a housing 10, a slider 20, a printed circuit board holder 30, a battery 40, a printed circuit board 50, a spring 60, and an end cap 70. The printed circuit board 50 includes a plurality of contacts—in this case, a positive potential 52 and a negative potential 53. The battery 40 is a button-cell type battery that is pressed against the positive potential 52 and the negative potential 53 of the printed circuit board assembly 50 by the spring 60 that is held inside of the housing assembly 10 by the end cap 70. The battery 40 is positioned between the printed circuit board assembly 50 and the end cap 70. The spring 60 is configured to promote contact between the battery 40 and the contacts 52, 53 on the printed circuit board 50. The transmitter unit 1 can be turned on and off through use of the slider 20 to activate a micro-switch 51.

[0042] As seen in FIG. 5, the housing 10 may include a housing body 11, a cone 12, and a cap 13. The cone 12 and cap 13 may be used to secure a sensor guide wire to the housing, and inhibit the sensor guide wire from detaching from the printed circuit board 50 (as seen in FIG. 2A). The housing assembly 10 may be made of plastic molded pieces. The housing assembly 10 is designed to contain the other components of the transmitter unit 1 as seen in FIG. 2C. The housing body 11 has an opening 14 through which a slider protrusion 21 can extend. The opening 14 also has space in which a slider guide 22 is engaged, as seen in FIG. 2A. The housing body 11 has internal ribs 15 used to secure the end cap 70. The end cap 70 has external ribs 71 to secure it to the housing body 11. By securing the end cap 70 to the housing body 11, the other components can be secured inside of the transmitter unit. The housing body 11 is configured so that the battery 40 may be disposed inside of the housing body 11 such that the battery 40 may be easily removed and replaced. The housing body 11 is configured to house the battery 40 between the printed circuit board 30 and the end cap 70.

[0043] As seen in FIGS. 4A-4E, the slider 20 has the protrusion 21. The protrusion 21 is used to activate the micro-switch 51 on the printed circuit board 50 (as seen in FIG. 2A). The protrusion 21 may be offset from a longitudinal center

plane of the slider **20** as seen in FIG. 4D, in order to activate the micro-switch **51** that is offset from a longitudinal center plane of the printed circuit board **50**. The slider **20** also has the slider guide **22** configured to keep the slider **20** attached to the housing body **11** and guide the slider **20** through the housing opening **14**. This will allow the protrusion **21** to be aligned with the micro-switch **51**. This alignment allows the protrusion **21** to be able to activate the micro-switch. Additionally, the slider has a ribbed surface **23** configured to facilitate the sliding of the slider **20** by a user.

[0044] As seen in FIGS. 6A and 6B, the printed circuit board holder **30** is configured to hold the printed circuit board assembly **50**. The printed circuit board holder **30** has an opening **31** through which the protrusion **21** extends.

[0045] As seen in FIG. 3 the printed circuit board assembly **50** comprises the micro-switch **51**, the positive potential **52**, and the negative potential **53**. The micro-switch **51** is a switch that may be activated by the protrusion **21** being slid over the switch to a position past the switch or a switch that may be activated by the protrusion being slid to a position above the switch. The micro-switch is used to turn the transmitter unit **1** on and off. The micro-switch **51** is located offset from the longitudinal center plane in order to interact with the protrusion **21** which is offset from the longitudinal center plane. The positive potential **52** and negative potential **53** are designed to contact the battery **40**.

[0046] A transmitter unit with a battery contained inside the unit and a micro-switch allows the unit to be prepared ahead of time but only turned on when necessary by moving the slider to activate the micro-switch. This design also allows the sterilization process of the device to be less time consuming as compared to those that have a separate battery pack that must be sterilized separately. Additionally, containing all of the components within one unit reduces the size and complexity of the device. Finally, the battery may be replaced so that the transmitter unit is reusable.

[0047] In some embodiments, the transmitter unit includes a receiver unit. In this case, the unit is, in fact a transceiver unit, such that communication with the external device may be two-way communication.

[0048] The foregoing description of embodiments has been presented for purposes of illustration and description. The foregoing description is not intended to be exhaustive or to limit embodiments of the present invention to the precise form disclosed, and modifications and variations are possible in light of the above teachings or may be acquired from practice of various embodiments. The embodiments discussed herein were chosen and described in order to explain the principles and the nature of various embodiments and its practical application to enable one skilled in the art to utilize the present invention in various embodiments and with various modifications as are suited to the particular use contemplated. The features of the embodiments described herein may be combined in all possible combinations of components, methods, apparatus, modules, systems, and computer program products.

What is claimed is:

1. A device comprising:

a transmitter unit configured to be connected to a sensor guide wire that is insertable into a patient to measure a parameter, the transmitter unit being configured to wirelessly transfer data representing the measured parameter to a communication unit, and the transmitter unit comprising:

a housing,
a printed circuit board holder disposed in the housing,
a printed circuit board disposed in the housing and held by the printed circuit board holder, the printed circuit board comprising a plurality of electrical contacts,
a slider that is slidable from a location outside the housing, the slider including a protrusion extending into an area inside the housing, and
a space within the housing, the space being configured to hold one or more batteries,
wherein the slider is slidable from a first position, at which a micro-switch is not activated, to a second position, at which the micro-switch is activated by the protrusion of the slider, which allows power to be provided to the printed circuit board.

2. The device of claim 1, wherein the space within the housing is configured to hold one or more button-cell type batteries.

3. The device of claim 1, wherein the housing comprises at least one member configured to secure the sensor guide wire to the housing.

4. The device of claim 1, further comprising an end cap configured to secure the one or more batteries inside of the housing.

5. The device of claim 4, further comprising a spring located between the one or more batteries and the end cap to promote contact between the one or more batteries and at least one of the electrical contacts on the printed circuit board.

6. The device of claim 4, wherein the end cap is attached by threads, screws, snaps, or barbs.

7. The device of claim 1, wherein the outer surface of the slider is ribbed.

8. The device of claim 1, wherein the parameter is pressure, temperature, or flow.

9. The device of claim 1, further comprising a receiver module to form a transceiver unit.

10. The device of claim 1, further comprising a sensor guide wire configured to be inserted into a patient to measure a physiological parameter.

11. The device of claim 1, wherein the transmitter unit is adapted to communicate by a radio frequency signal with a communication unit, arranged in connection with an external device.

12. The device of claim 1, wherein the protrusion is offset from the center of the slider.

13. The device of claim 1, wherein the housing has an opening through which the protrusion extends.

14. The device of claim 1, wherein the printed circuit board holder has an opening through which the protrusion extends.

15. The device of claim 1, wherein the micro-switch is activated by the protrusion being slid over the micro-switch to a position past the micro-switch.

16. The device of claim 1, wherein the micro-switch is activated by the protrusion being slid to a position above the micro-switch.

17. The device of claim 1, wherein the space within the housing is configured to hold one or more batteries in a position where the longitudinal axis of the one or more batteries is aligned with the longitudinal axis of the housing.

18. The device of claim 4, wherein the space within the housing configured to hold one or more batteries is located between the printed circuit board and the end cap.

专利名称(译)	带纽扣电池的传感器导线组件		
公开(公告)号	US20160045164A1	公开(公告)日	2016-02-18
申请号	US14/458400	申请日	2014-08-13
[标]申请(专利权)人(译)	ST犹达医疗SYST		
申请(专利权)人(译)	ST.犹达医疗系统公司		
当前申请(专利权)人(译)	ST.犹达医疗系统公司		
[标]发明人	TIENSUU STEFAN		
发明人	TIENSUU, STEFAN		
IPC分类号	A61B5/00 A61B5/01 A61B5/0215 A61B5/026 A61B5/07 H04B13/00		
CPC分类号	A61B5/6851 H04B13/005 A61B5/026 A61B5/0215 A61B5/01 A61B5/07		
其他公开文献	US10039493		
外部链接	Espacenet	USPTO	

摘要(译)

具有纽扣电池型电池的传感器导丝组件包括发送器单元，该发送器单元被配置为连接到可插入患者以测量参数的传感器导丝，该发送器单元被配置为将表示测量参数的数据无线传输到通讯单位。发送器单元包括壳体，设置在壳体中的印刷电路板支架，以及设置在壳体中并由印刷电路板支架保持的印刷电路板。印刷电路板包括多个电触点。滑块可从壳体外部的的位置滑动，滑块包括延伸到壳体内部区域的突起。壳体内部空间构造保持一个或多个电池。滑块可从第一位置滑动到第二位置，在第一位置微动开关不被激活，在第二位置，微动开关由滑动器的突起激活，这允许向印刷电路板提供电力。

