

US009668685B2

(12) **United States Patent**  
**Bommakanti et al.**

(10) **Patent No.:** **US 9,668,685 B2**  
(45) **Date of Patent:** **\*Jun. 6, 2017**

(54) **ANALYTE SENSORS COMPRISING HYDROGEL MEMBRANES**

*A61B 5/14532* (2013.01); *A61B 5/4839* (2013.01); *A61B 5/742* (2013.01); *A61B 5/746* (2013.01); *A61B 5/145* (2013.01)

(71) Applicant: **Abbott Diabetes Care Inc.**, Alameda, CA (US)

(58) **Field of Classification Search**  
CPC ..... *A61B 5/14532*; *A61B 5/1473*; *A61B 5/14865*; *A61B 5/1486*  
See application file for complete search history.

(72) Inventors: **Balasubrahmanya S. Bommakanti**, Pleasanton, CA (US); **Gary Sandhu**, Fairfield, CA (US); **Udo Hoss**, Castro Valley, CA (US)

(56) **References Cited**

(73) Assignee: **Abbott Diabetes Care Inc.**, Alameda, CA (US)

U.S. PATENT DOCUMENTS

(\* ) Notice: Subject to any disclaimer, the term of this patent is extended or adjusted under 35 U.S.C. 154(b) by 192 days.  
This patent is subject to a terminal disclaimer.

5,262,035 A	11/1993	Gregg
5,262,305 A	11/1993	Heller
5,264,104 A	11/1993	Gregg
5,320,725 A	6/1994	Gregg et al.
5,593,852 A	1/1997	Heller
6,134,461 A	10/2000	Say
6,143,164 A	11/2000	Heller
6,175,752 B1	1/2001	Say
6,338,790 B1	1/2002	Feldman

(Continued)

(21) Appl. No.: **14/719,820**

*Primary Examiner* — Christian Jang

(22) Filed: **May 22, 2015**

(74) *Attorney, Agent, or Firm* — Edward J. Baba; Bozicevic, Field & Francis LLP

(65) **Prior Publication Data**

US 2015/0250412 A1 Sep. 10, 2015

**Related U.S. Application Data**

(63) Continuation of application No. 12/625,208, filed on Nov. 24, 2009, now Pat. No. 9,042,954.

(57) **ABSTRACT**

(51) **Int. Cl.**

- A61B 5/05* (2006.01)
- A61B 5/1486* (2006.01)
- A61B 5/145* (2006.01)
- A61B 5/1473* (2006.01)
- A61B 5/00* (2006.01)
- A61B 5/1495* (2006.01)

Generally, embodiments of the present disclosure relate to analyte determining methods and devices (e.g., electrochemical analyte monitoring systems) that have improved signal response and stability by inclusion of a coating including a hydrogel, a crosslinker, and a swelling modulator, where the coating is disposed proximate to a working electrode of in vivo and/or in vitro analyte sensors, e.g., continuous and/or automatic in vivo monitoring using analyte sensors and/or test strips. Also provided are systems and methods of using the, for example electrochemical, analyte sensors in analyte monitoring.

(52) **U.S. Cl.**

CPC ..... *A61B 5/14865* (2013.01); *A61B 5/0004* (2013.01); *A61B 5/1473* (2013.01); *A61B 5/1486* (2013.01); *A61B 5/1495* (2013.01);

**29 Claims, 28 Drawing Sheets**

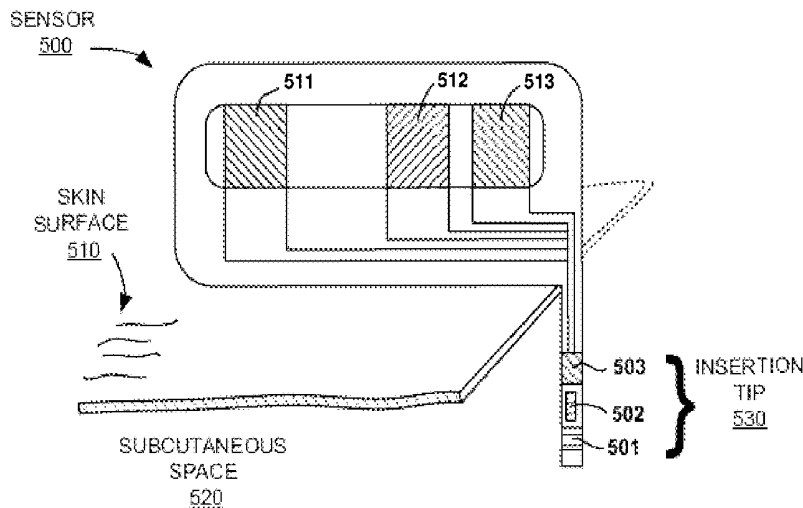

(56)

**References Cited**

U.S. PATENT DOCUMENTS

6,560,471	B1	5/2003	Heller et al.
6,579,690	B1	6/2003	Bonnecaze
6,605,200	B1	8/2003	Mao
6,605,201	B1	8/2003	Mao
6,654,625	B1	11/2003	Say
6,736,957	B1	5/2004	Forrow
6,746,582	B2	6/2004	Heller et al.
6,818,018	B1	11/2004	Sawhney
6,932,894	B2	8/2005	Mao
7,090,756	B2	8/2006	Mao
7,096,053	B2	8/2006	Loeb et al.
7,432,069	B2	10/2008	Barman et al.
7,501,053	B2	3/2009	Karinka
2004/0186365	A1	9/2004	Jin
2004/0202774	A1	10/2004	Chudzik et al.
2005/0215871	A1	9/2005	Feldman et al.
2006/0201805	A1	9/2006	Forrow
2007/0191701	A1	8/2007	Feldman
2008/0177164	A1	7/2008	Heller
2008/0179187	A1	7/2008	Ouyang et al.

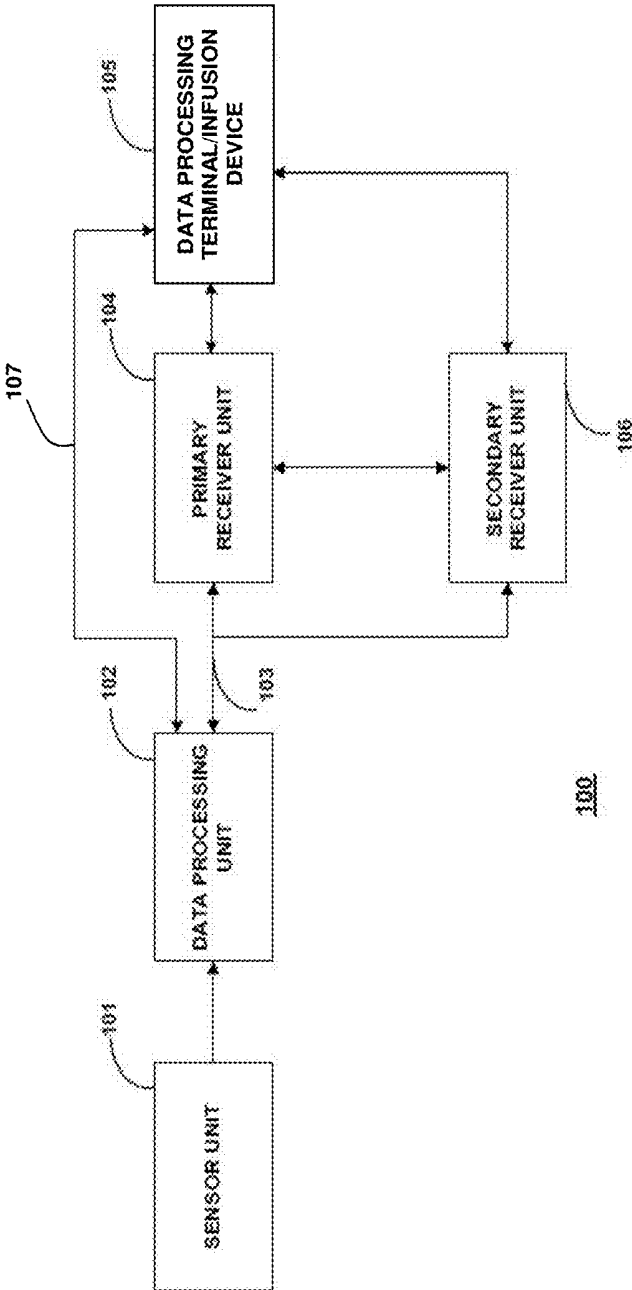

FIG. 1

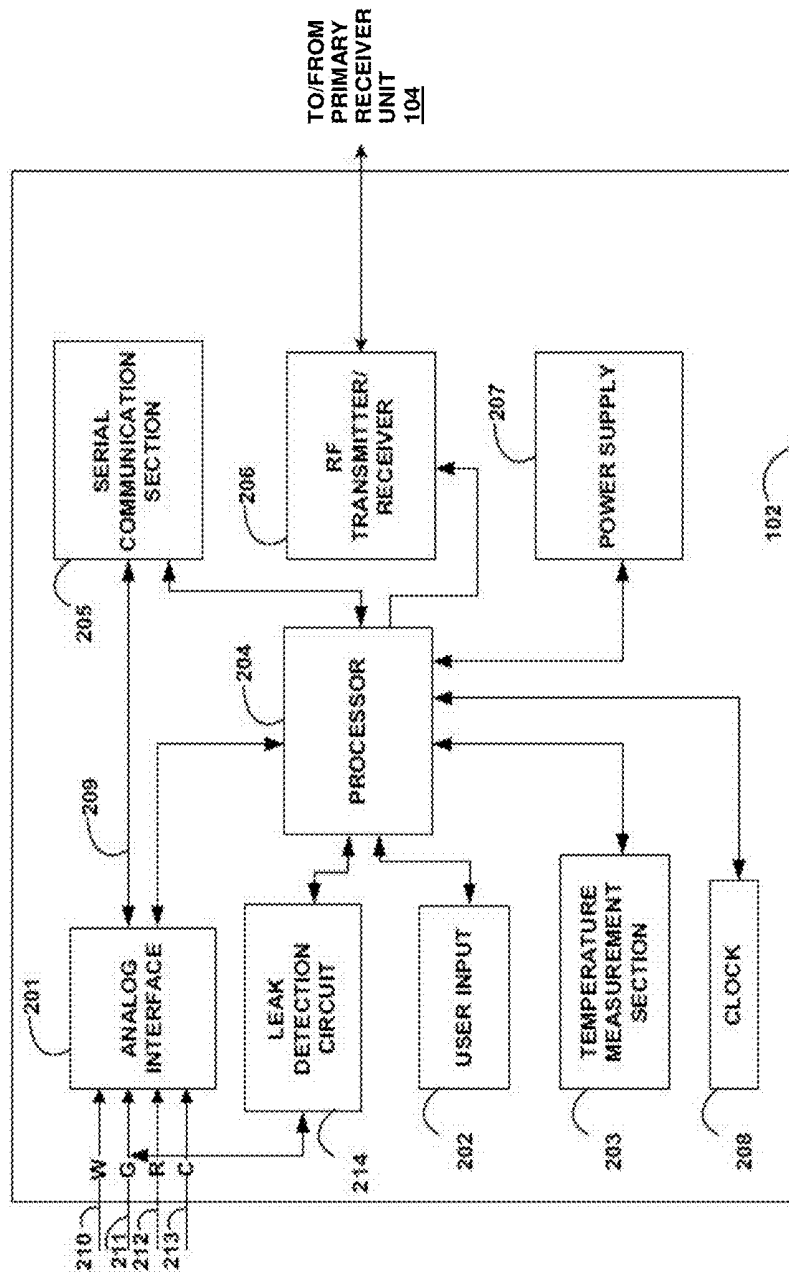

FIG. 2

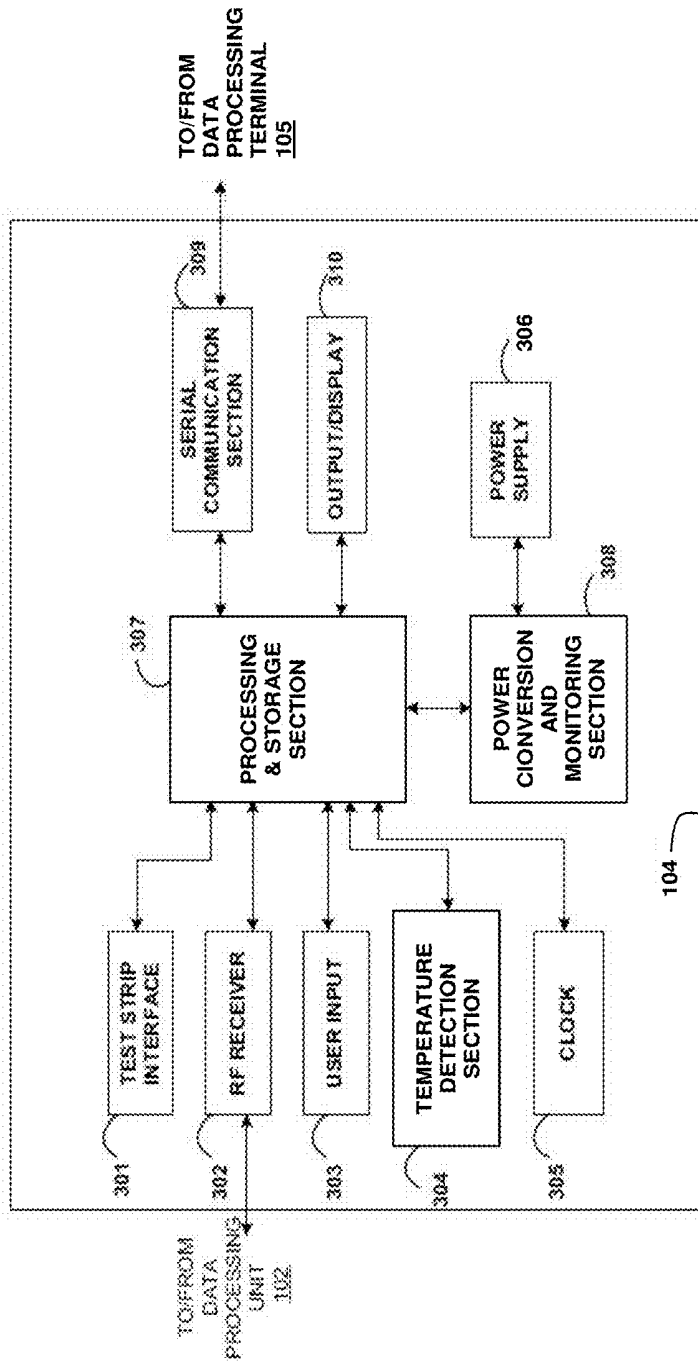

FIG. 3

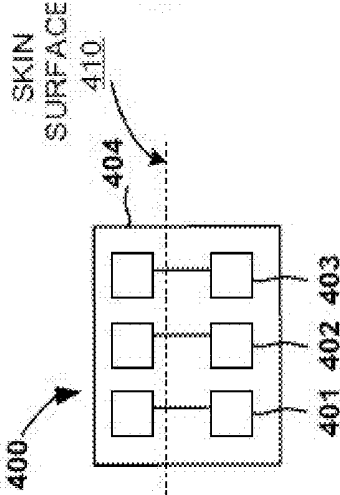

FIG. 4

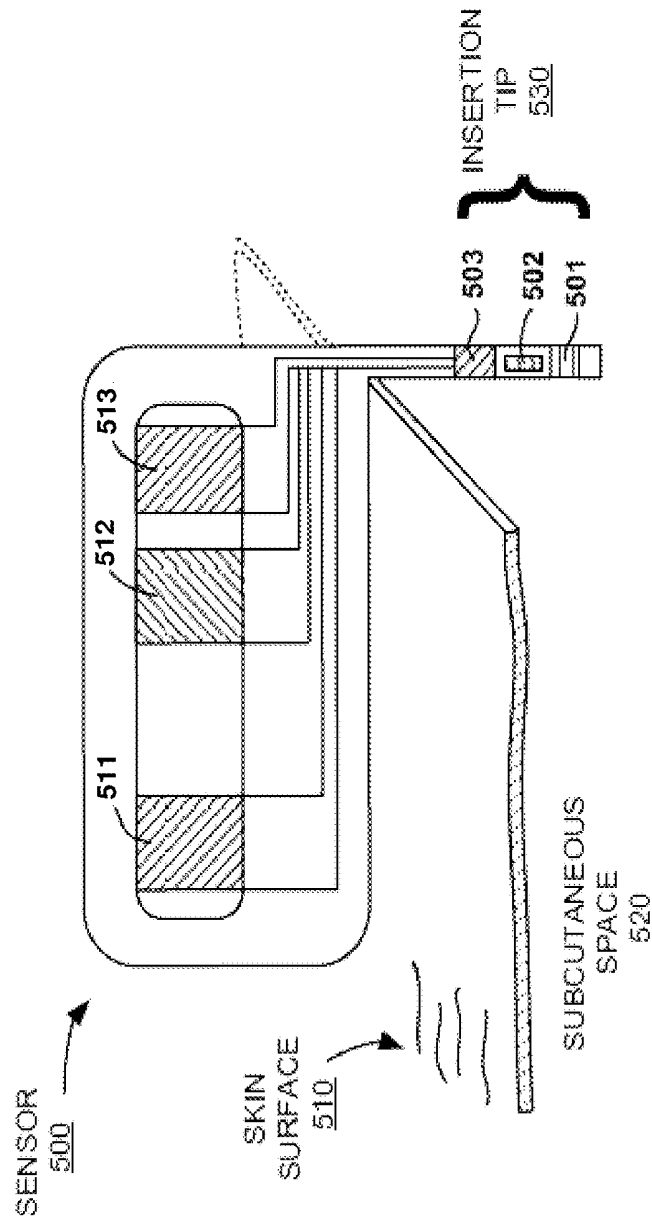

FIG. 5A

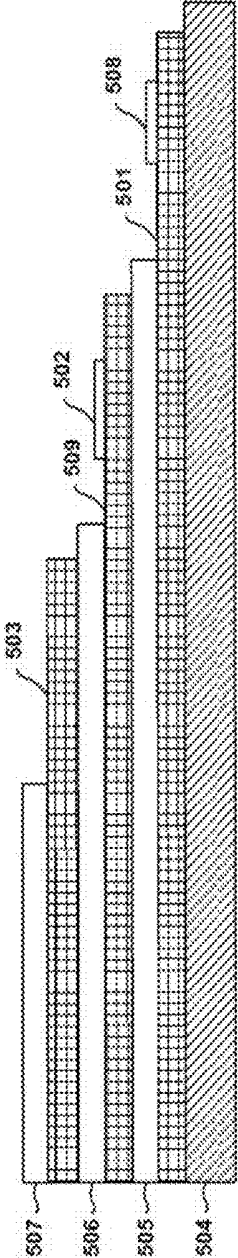
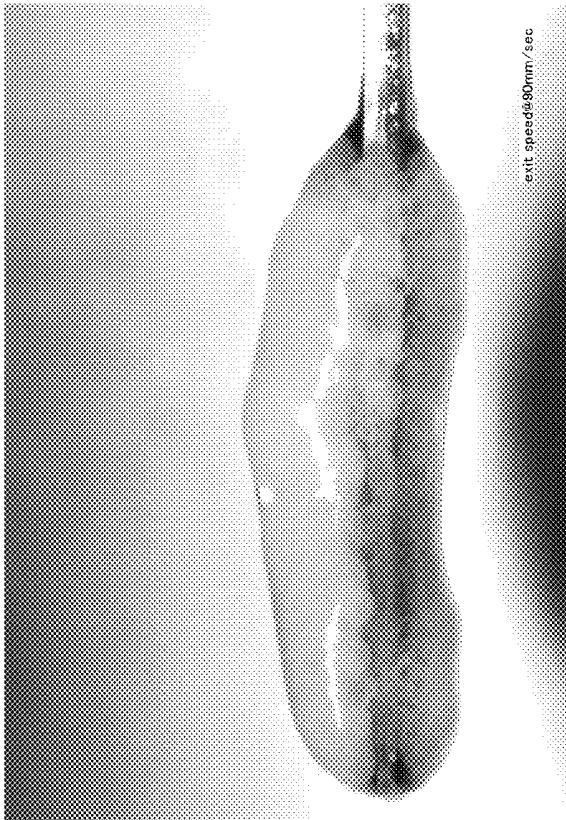

FIG. 5B



exit speed=90mm/sec

FIG. 6B

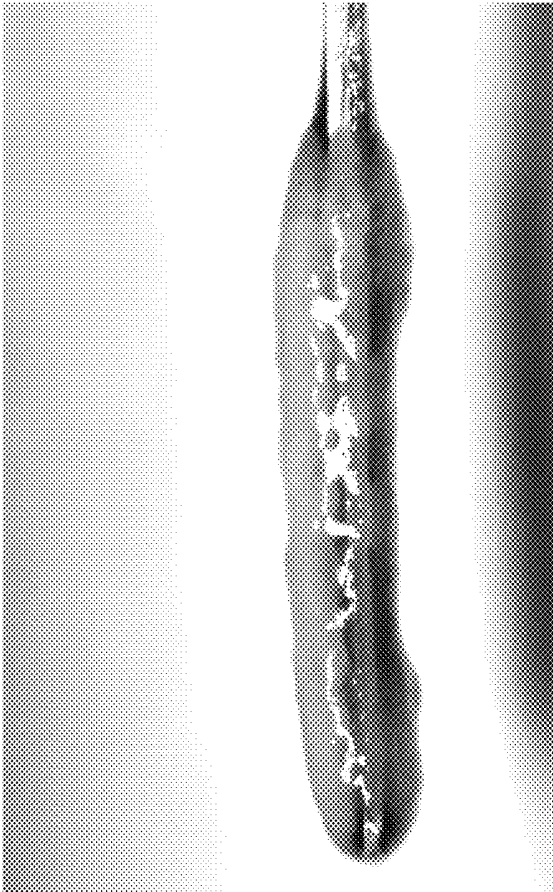

FIG. 6A

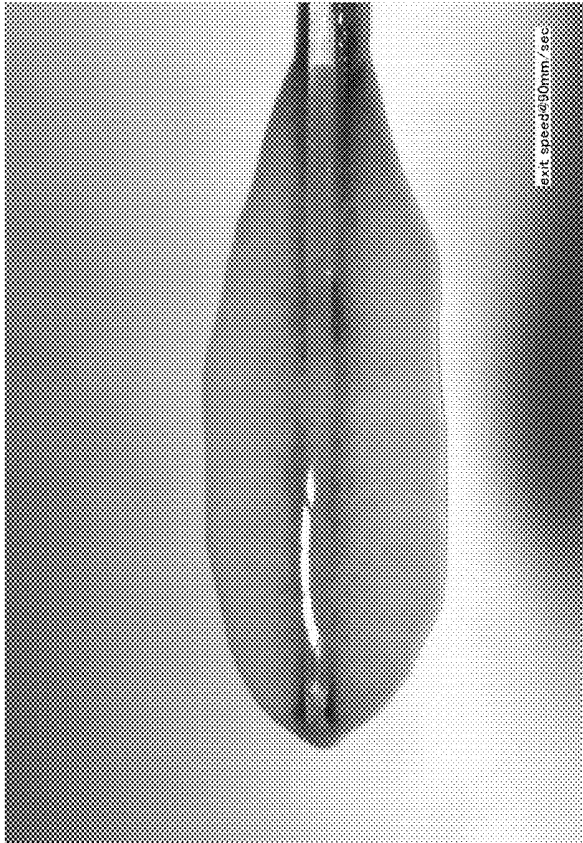

FIG. 7B

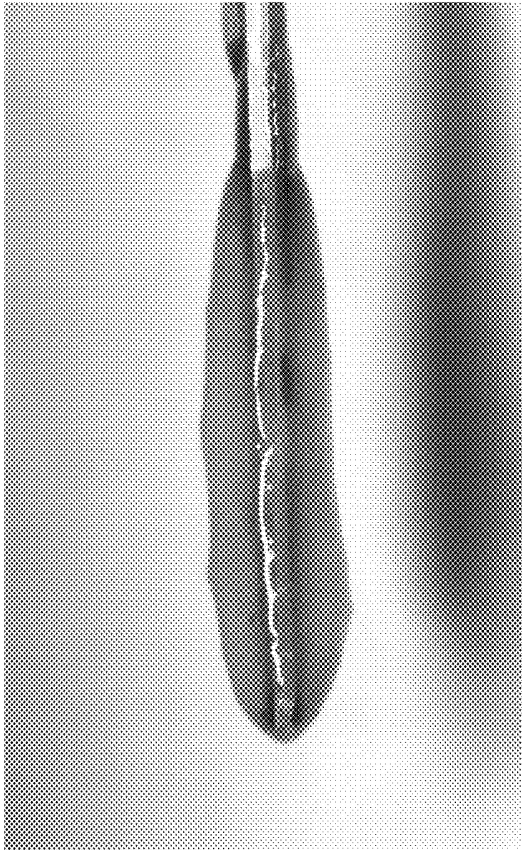

FIG. 7A



FIG. 8B

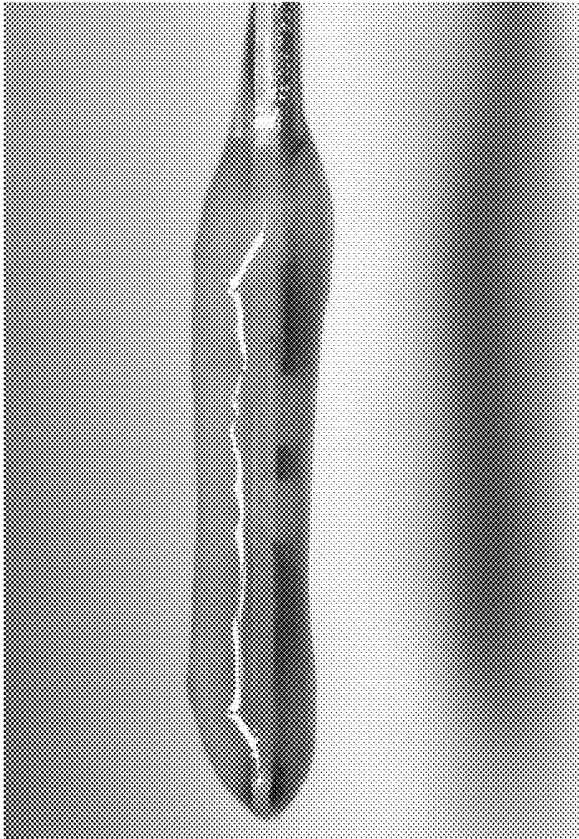

FIG. 8A

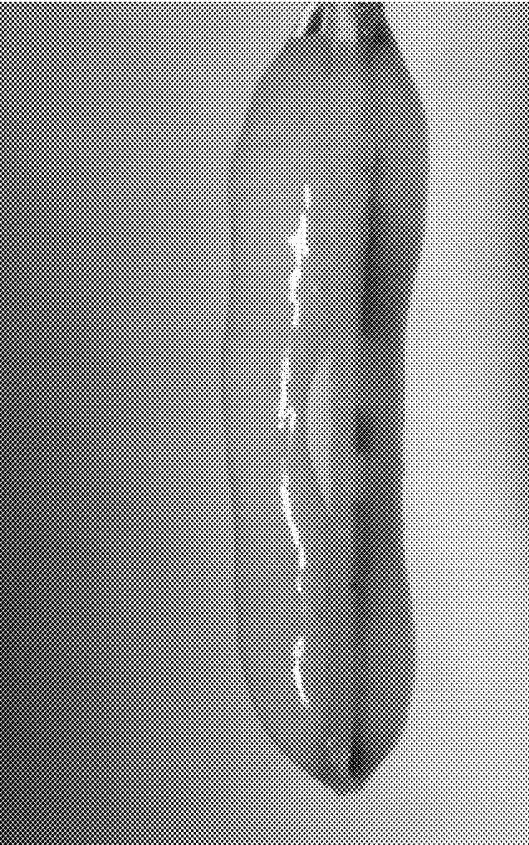

FIG. 9B

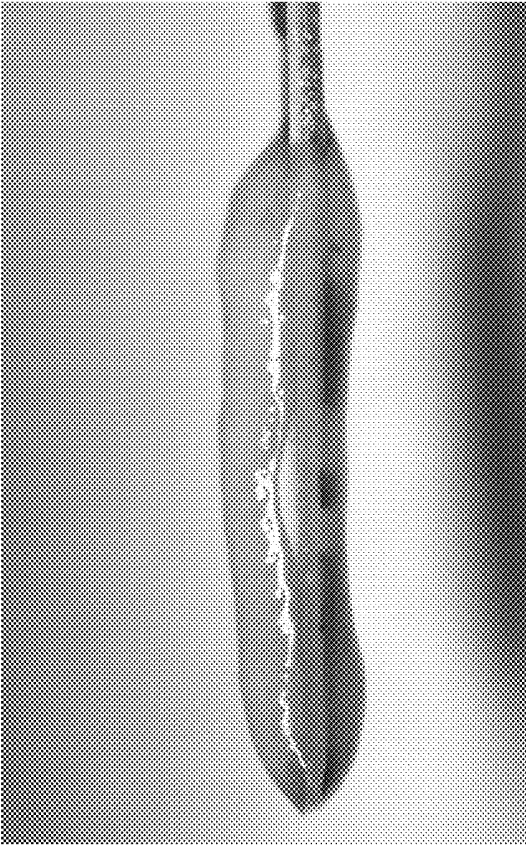

FIG. 9A

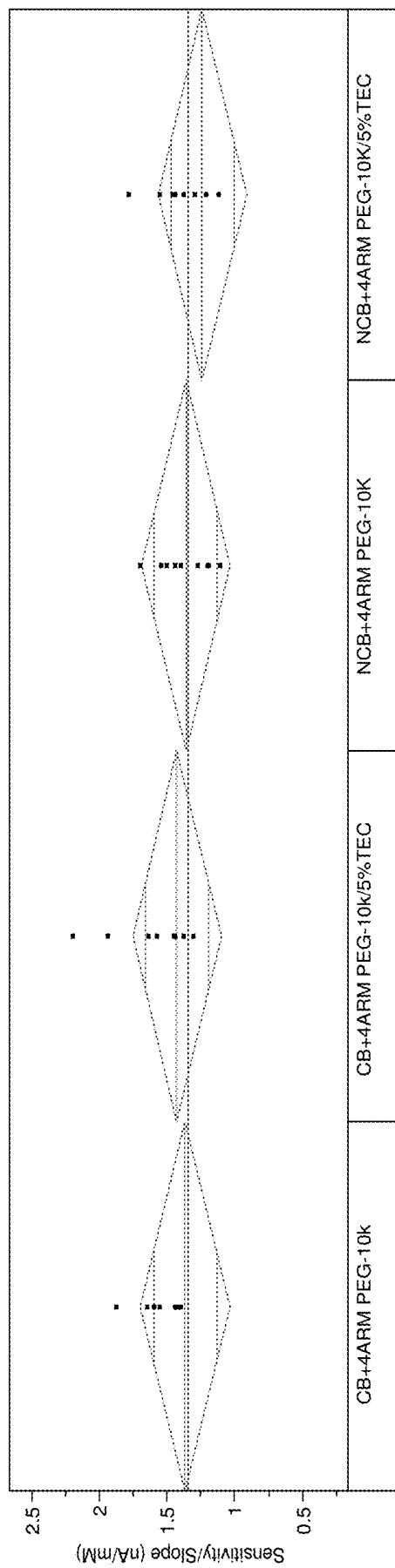

FIG. 10

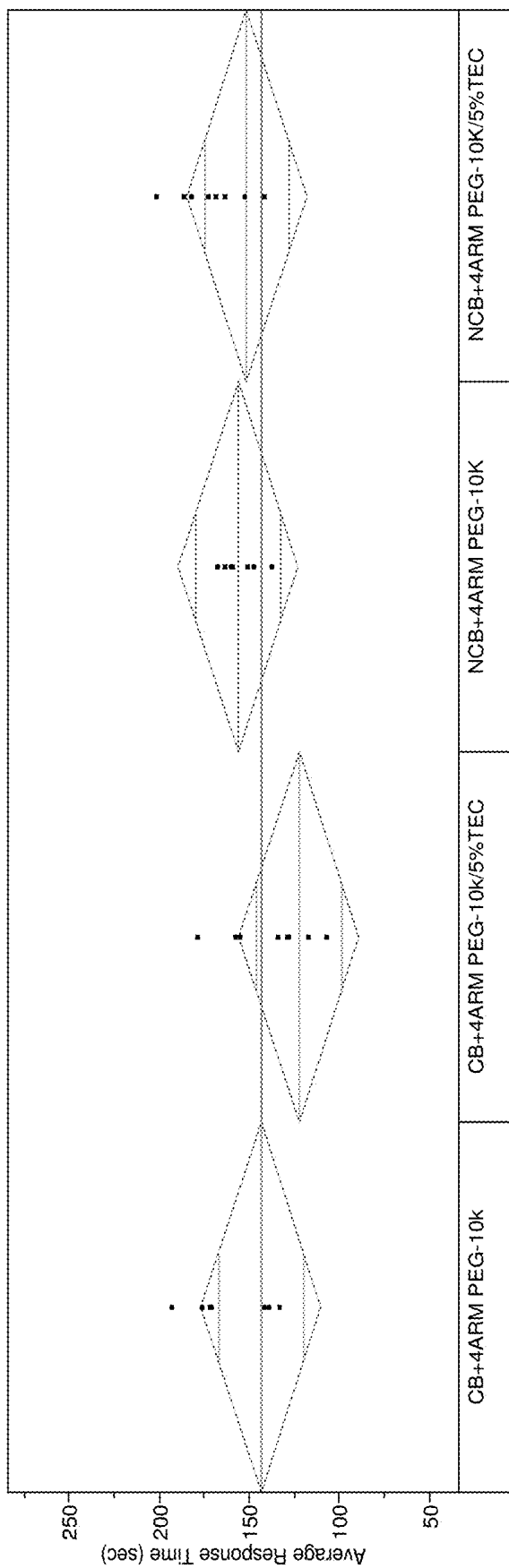

FIG. 11

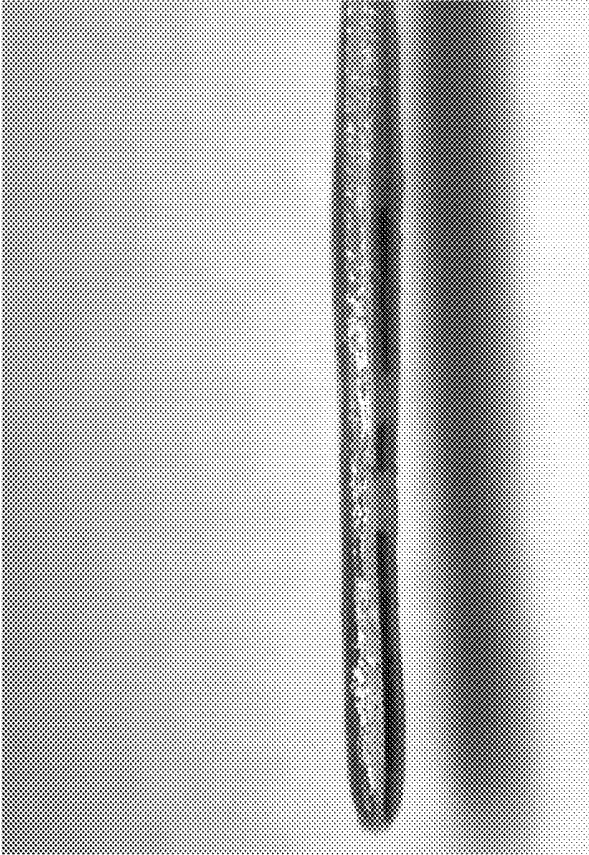

FIG. 12B

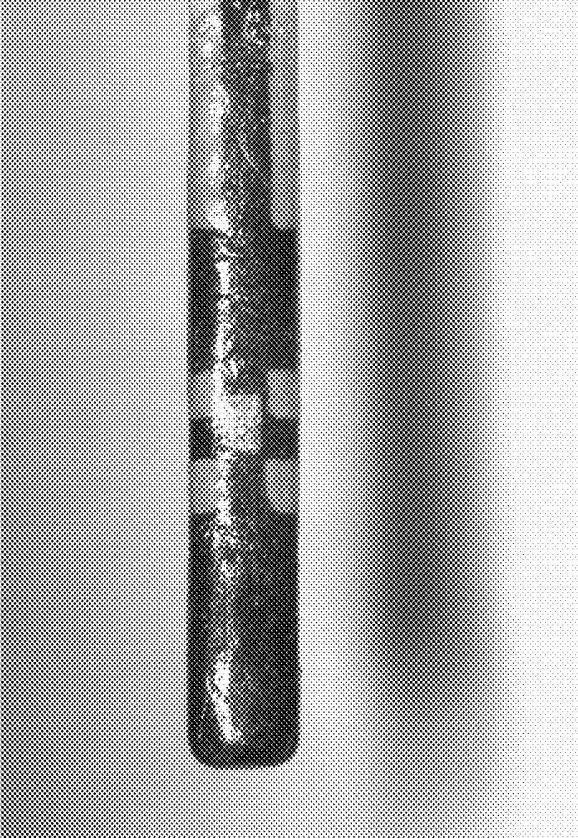

FIG. 12A

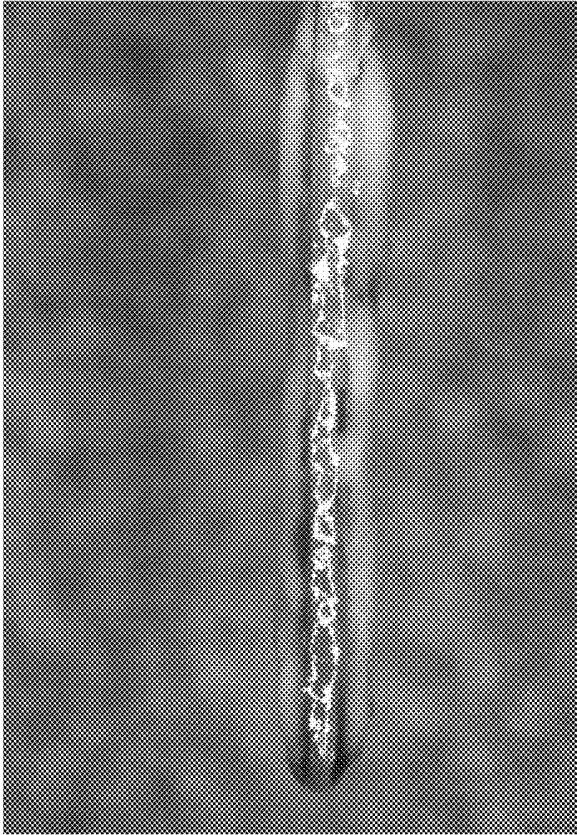

FIG. 13B

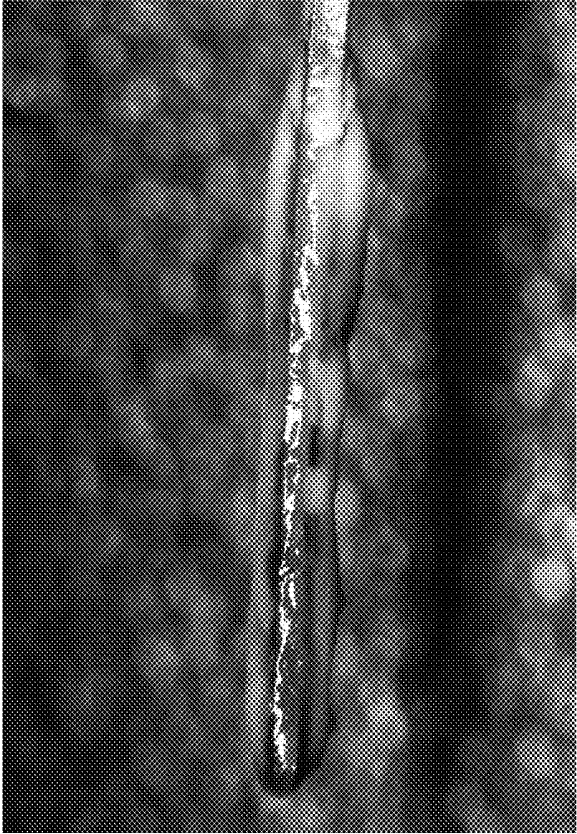

FIG. 13A

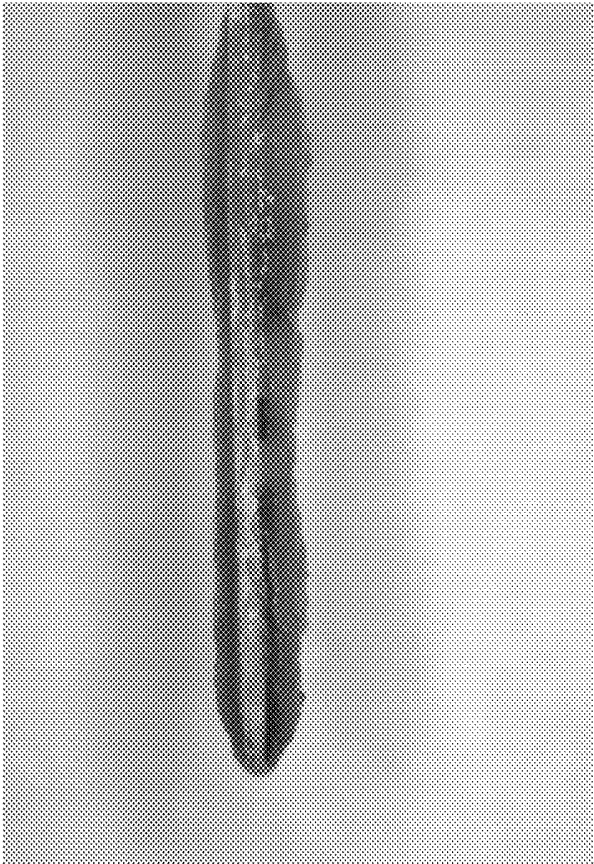

FIG. 13C

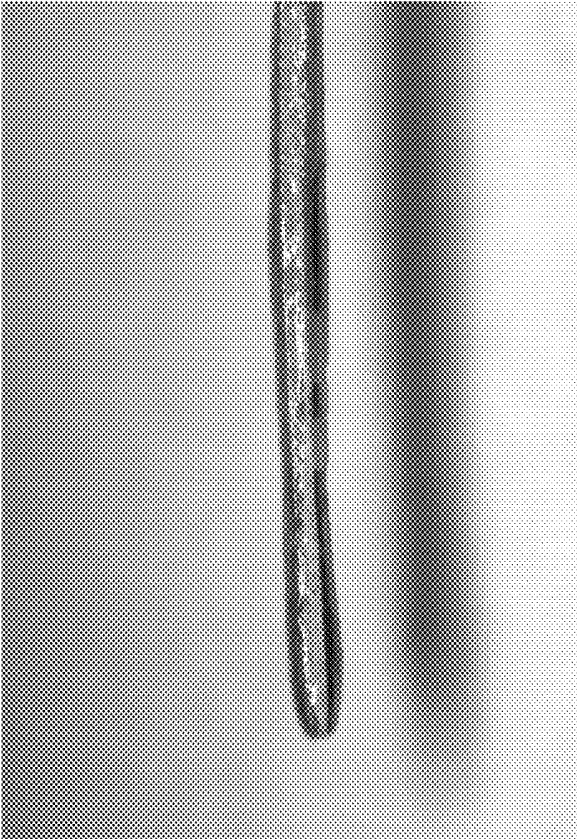

FIG. 14B

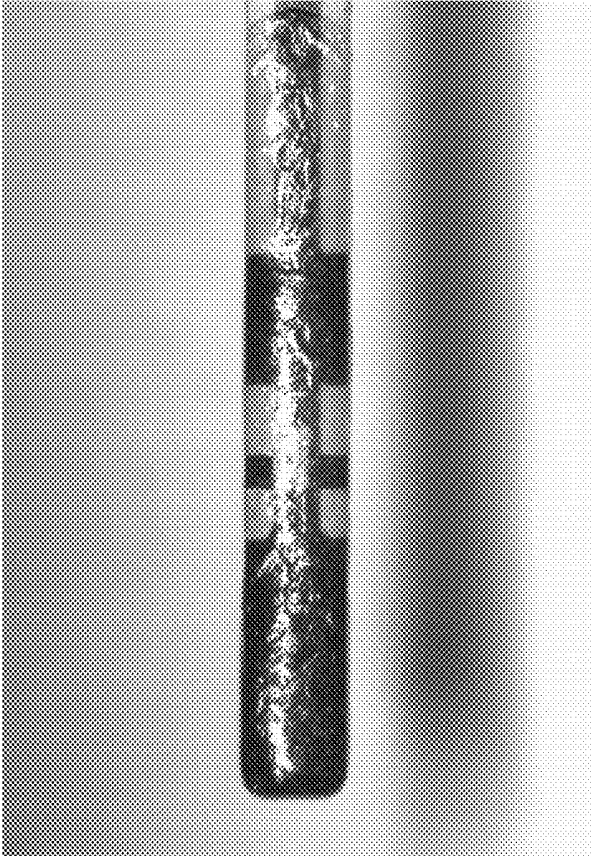

FIG. 14A

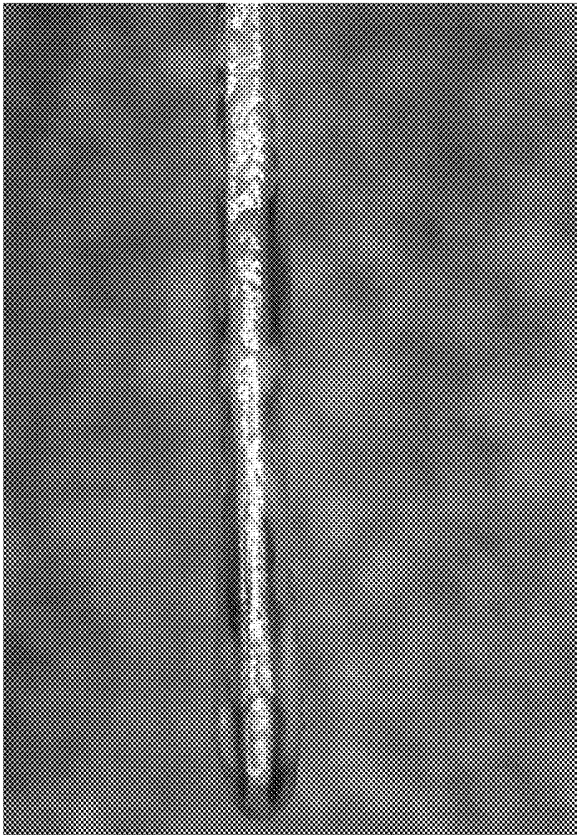

FIG. 15B

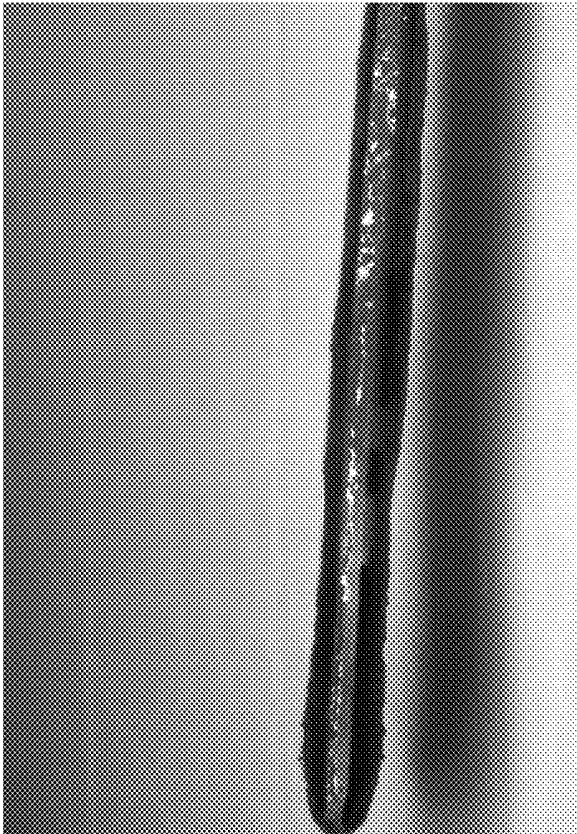

FIG. 15A

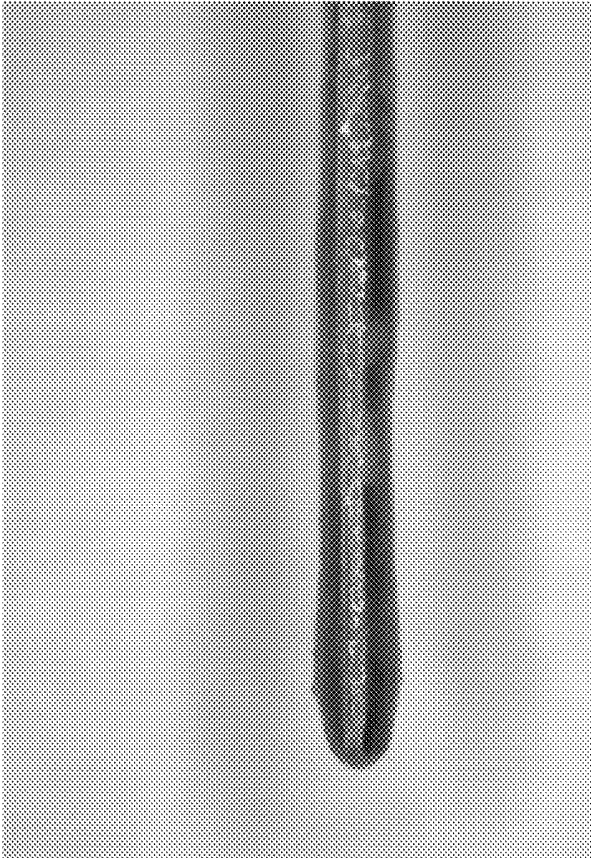

FIG. 15C

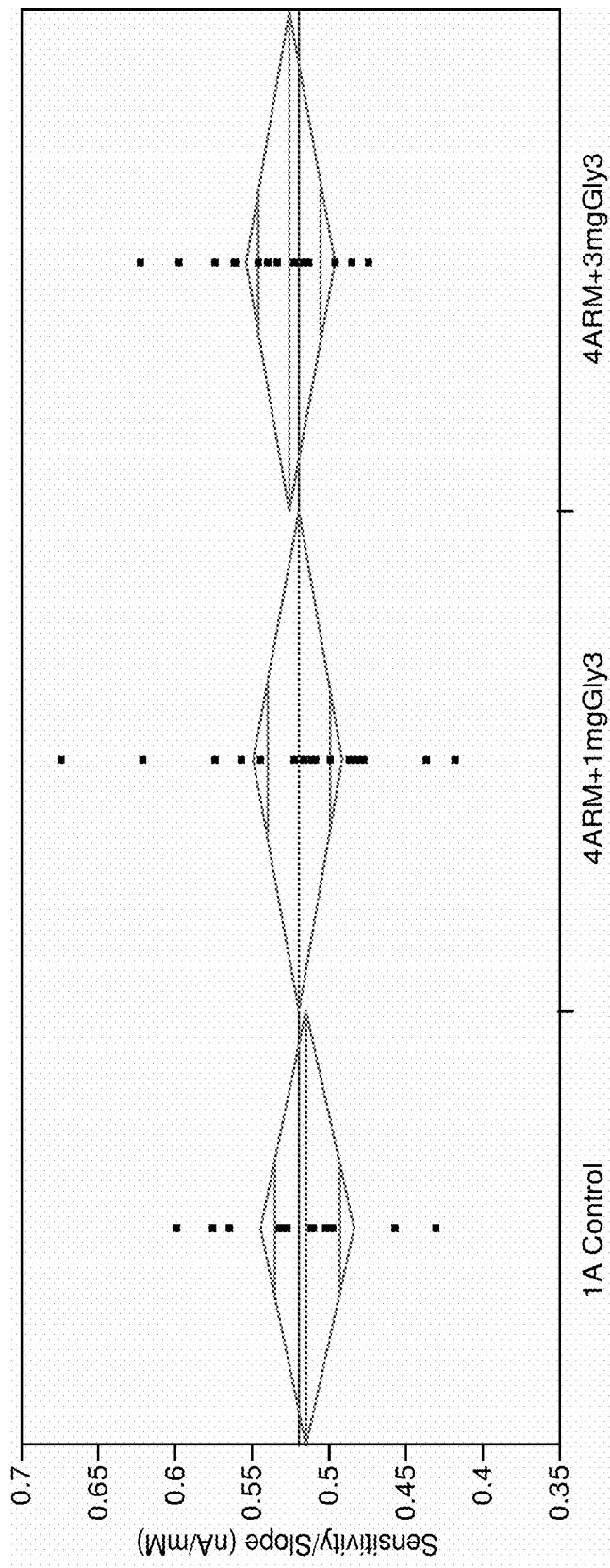

FIG. 16

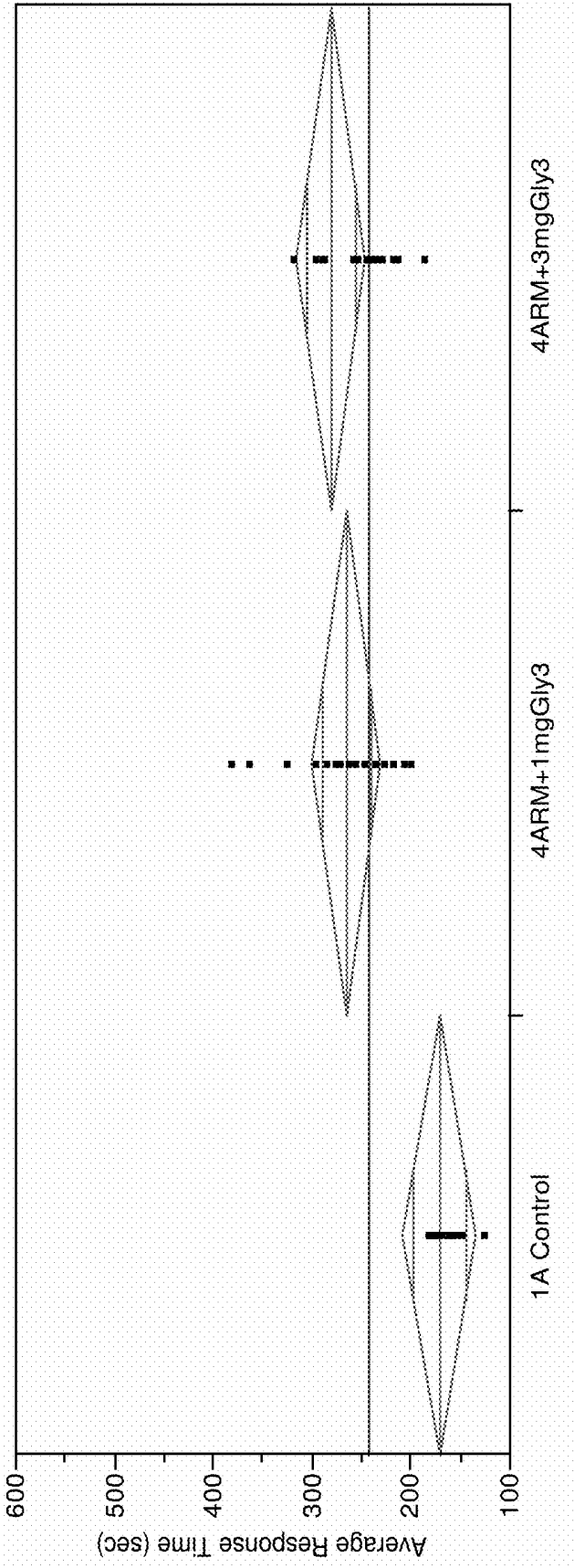

FIG. 17

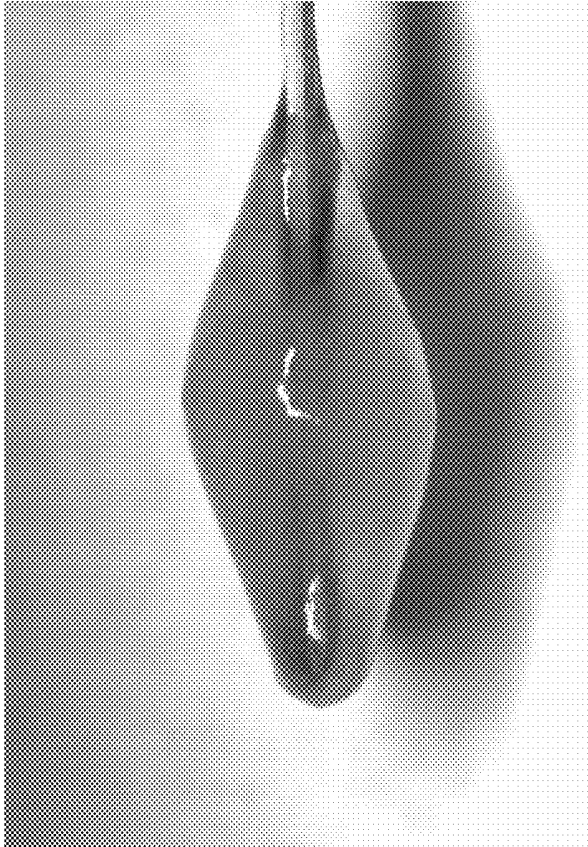

FIG. 18

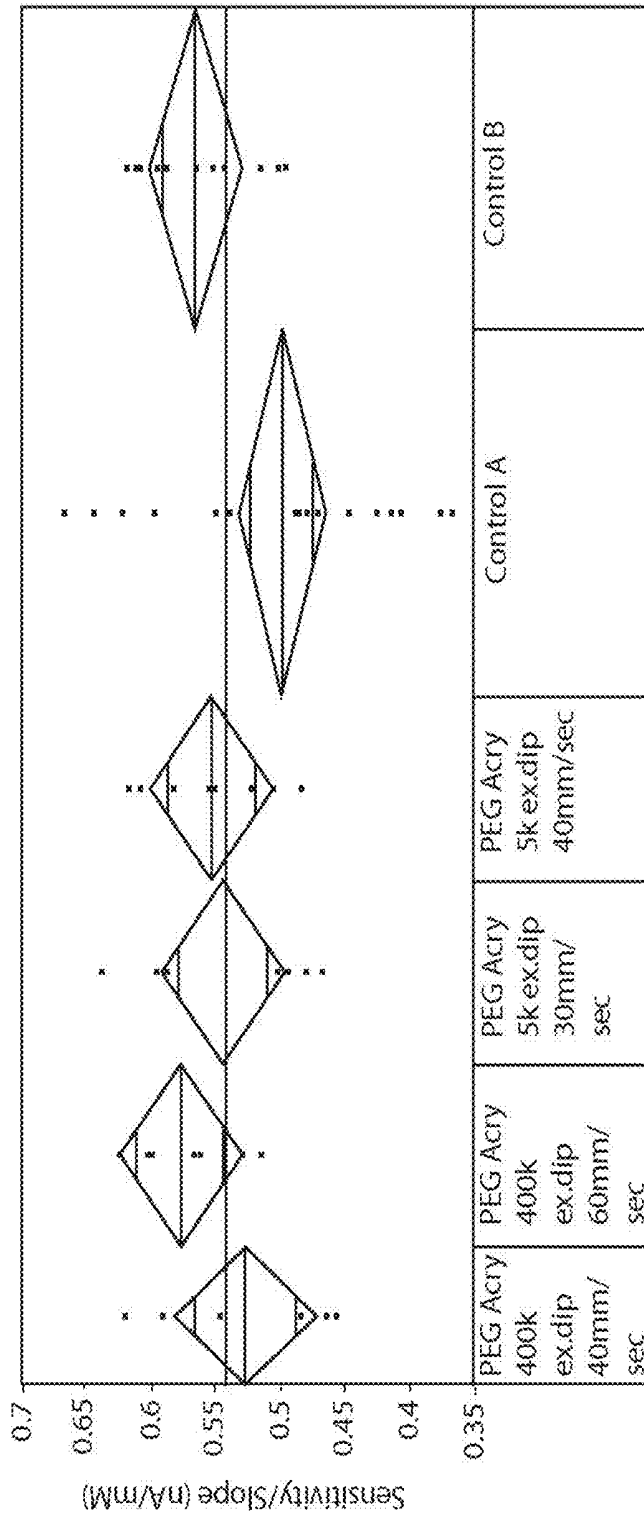

FIG. 19

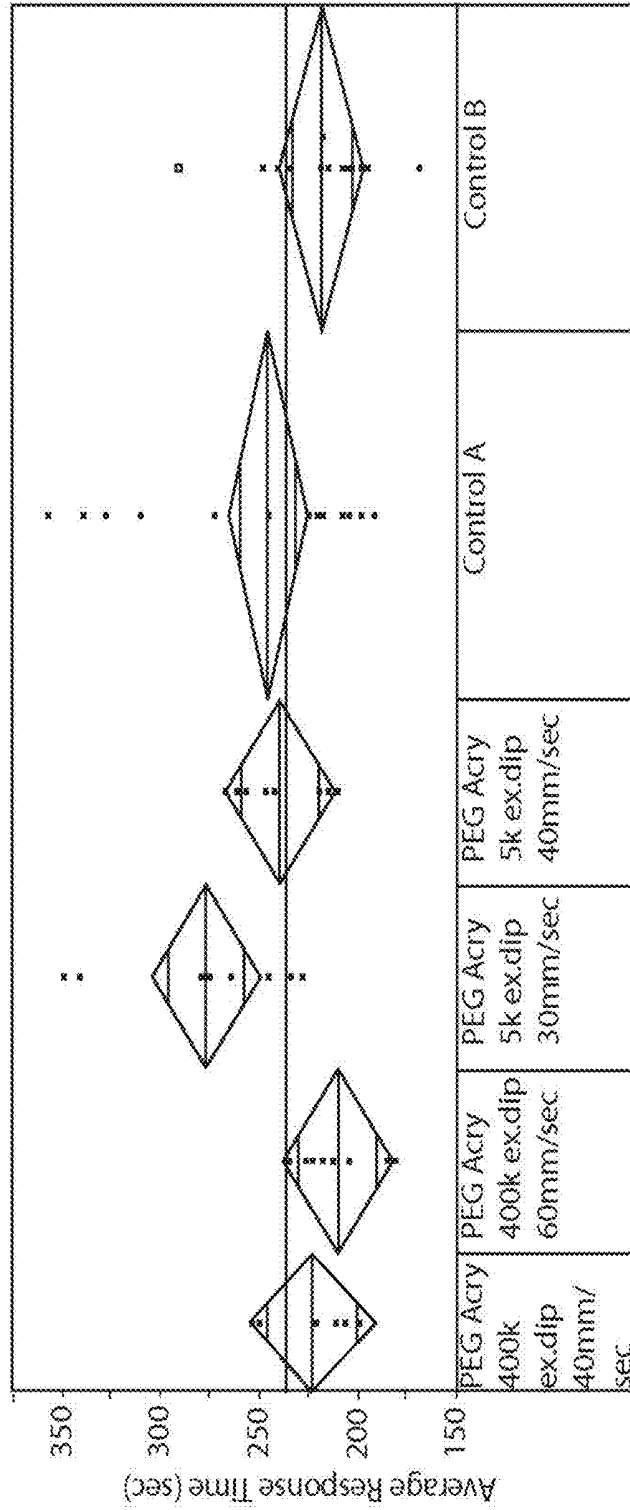

FIG. 20

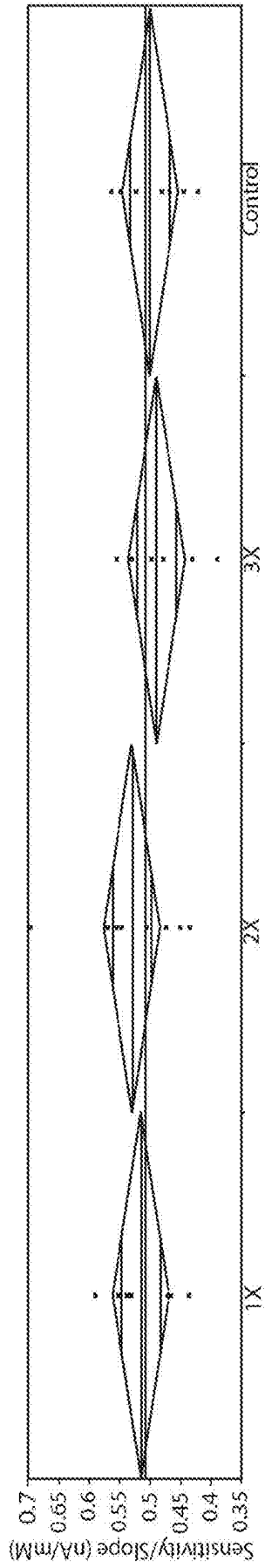

FIG. 21

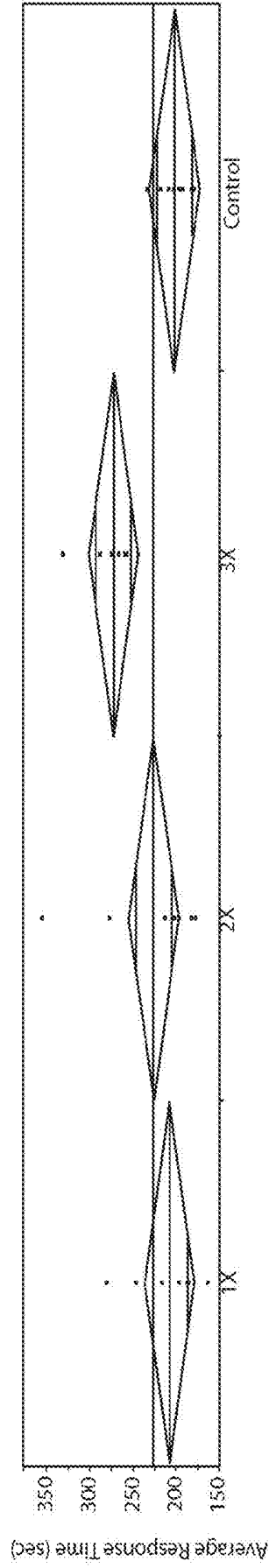

FIG. 22



FIG. 23B

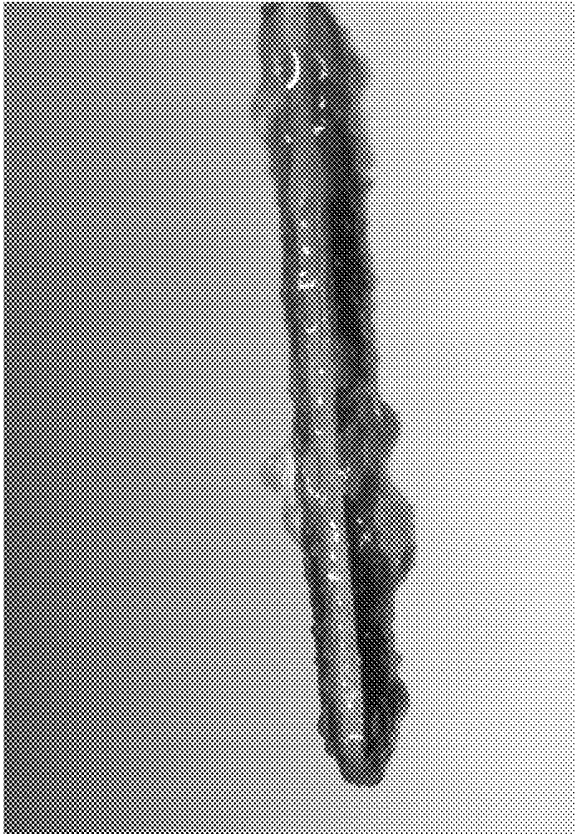

FIG. 23A



FIG. 24B



FIG. 24A

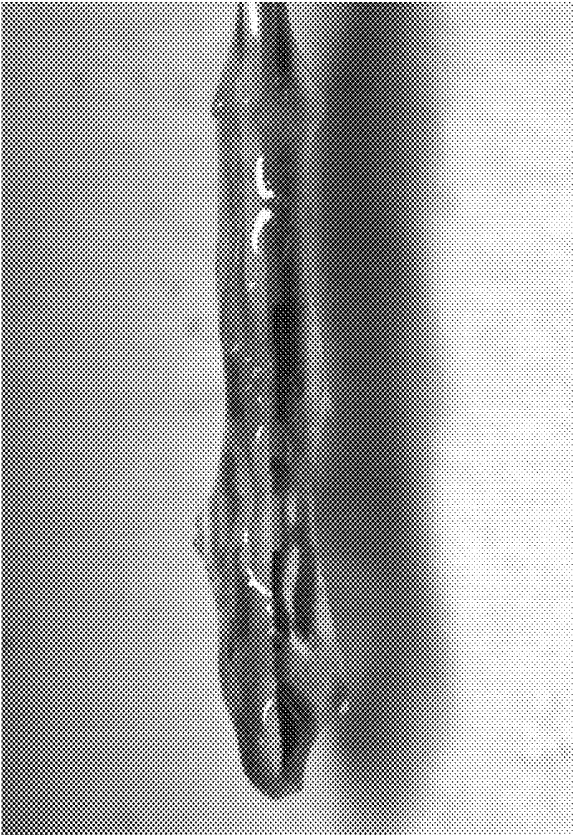

FIG. 25B



FIG. 25A

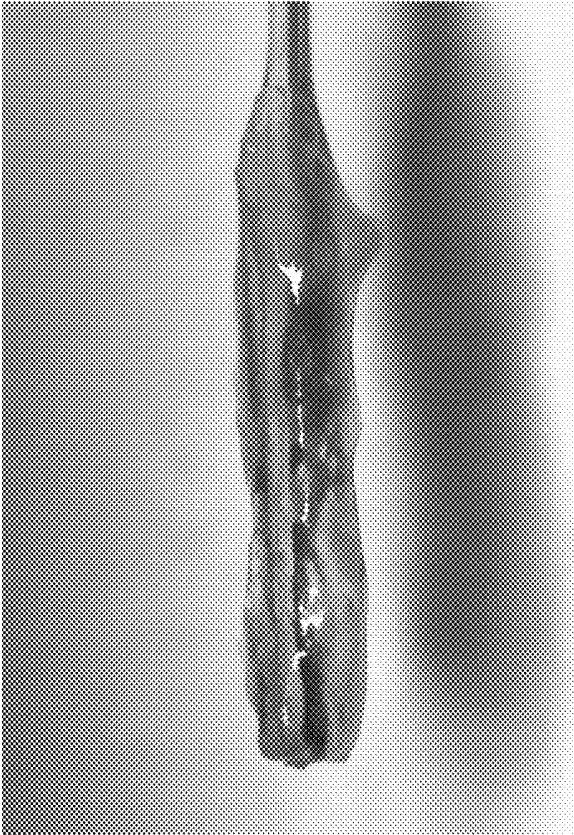

FIG. 26B

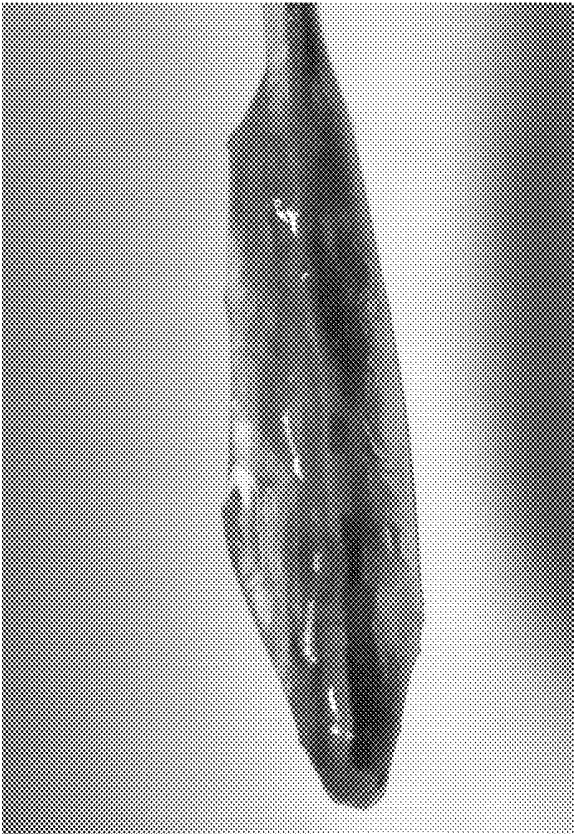

FIG. 26A

## ANALYTE SENSORS COMPRISING HYDROGEL MEMBRANES

### INTRODUCTION

In many instances it is desirable or necessary to regularly monitor the concentration of particular constituents in a fluid. A number of systems are available that analyze the constituents of bodily fluids such as blood, urine and saliva. Examples of such systems conveniently monitor the level of particular medically significant fluid constituents, such as, for example, cholesterol, ketones, vitamins, proteins, and various metabolites or blood sugars, such as glucose. Diagnosis and management of patients suffering from diabetes mellitus, a disorder of the pancreas where insufficient production of insulin prevents normal regulation of blood sugar levels, requires carefully monitoring of blood glucose levels on a daily basis. A number of systems that allow individuals to easily monitor their blood glucose are currently available. Such systems include electrochemical biosensors, including those that comprise a glucose sensor that is adapted for insertion into a subcutaneous site within the body for the continuous monitoring of glucose levels in bodily fluid of the subcutaneous site (see e.g., U.S. Pat. No. 6,175,752 to Say et al).

A person may obtain a blood sample by withdrawing blood from a blood source in his or her body, such as a vein, using a needle and syringe, for example, or by lancing a portion of his or her skin, using a lancing device, for example, to make blood available external to the skin, to obtain the necessary sample volume for in vitro testing. The person may then apply the fresh blood sample to a test strip, whereupon suitable detection methods, such as calorimetric, electrochemical, or photometric detection methods, for example, may be used to determine the person's actual blood glucose level. The foregoing procedure provides a blood glucose concentration for a particular or discrete point in time, and thus, must be repeated periodically, in order to monitor blood glucose over a longer period.

In addition to the discrete or periodic, in vitro, blood glucose-monitoring systems described above, at least partially implantable, or in vivo, blood glucose-monitoring systems, which are constructed to provide continuous in vivo measurement of an individual's blood glucose concentration, have been described and developed.

Such analyte monitoring devices are constructed to provide for continuous or automatic monitoring of analytes, such as glucose, in the blood stream or interstitial fluid. Such devices include electrochemical sensors, at least a portion of which are operably positioned in a blood vessel or in the subcutaneous tissue of a user.

While continuous glucose monitoring is desirable, there are several challenges associated with optimizing manufacture protocols to improve signal response and stability of the biosensors constructed for in vivo use. Accordingly, further development of manufacturing techniques and methods, as well as analyte-monitoring devices, systems, or kits employing the same, is desirable.

### SUMMARY

Generally, embodiments of the present disclosure relate to analyte determining methods and devices (e.g., electrochemical analyte monitoring systems) that have improved signal response and stability by inclusion of a coating including a hydrogel, a crosslinker, and a swelling modulator, where the coating is disposed proximate to a working

electrode of in vivo and/or in vitro analyte sensors, e.g., continuous and/or automatic in vivo monitoring using analyte sensors and/or test strips. Also provided are systems and methods of using the, for example electrochemical, analyte sensors in analyte monitoring.

### BRIEF DESCRIPTION OF THE DRAWINGS

A detailed description of various embodiments of the present disclosure are provided herein with reference to the accompanying drawings, which are briefly described below. The drawings are illustrative and are not necessarily drawn to scale. The drawings illustrate various embodiments of the present disclosure and may illustrate one or more embodiment(s) or example(s) of the present disclosure in whole or in part. A reference numeral, letter, and/or symbol that is used in one drawing to refer to a particular element maybe used in another drawing to refer to a like element.

FIG. 1 shows a block diagram of an embodiment of an analyte monitoring system according to embodiments of the present disclosure.

FIG. 2 shows a block diagram of an embodiment of a data processing unit of the analyte monitoring system shown in FIG. 1.

FIG. 3 shows a block diagram of an embodiment of the primary receiver unit of the analyte monitoring system of FIG. 1.

FIG. 4 shows a schematic diagram of an embodiment of an analyte sensor according to the embodiments of the present disclosure.

FIGS. 5A-5B show a perspective view and a cross sectional view, respectively, of an embodiment an analyte sensor.

FIGS. 6A-6B show microphotographs taken at 1 hour (FIG. 6A) and 24 hours (FIG. 6B), respectively, of a carbon backed sensor with a membrane that included a 10Q5-based hydrogel with a 4-arm PEG epoxide (10 kDa) crosslinker.

FIGS. 7A-7B show microphotographs taken at 1 hour (FIG. 7A) and 24 hours (FIG. 7B), respectively, of a carbon backed sensor with a membrane that included a 10Q5-based hydrogel with a 4-arm PEG epoxide (10 kDa) crosslinker and 5% TEC.

FIGS. 8A-8B show microphotographs taken at 1 hour (FIG. 8A) and 24 hours (FIG. 8B), respectively, of a non-carbon backed sensor with a membrane that included a 10Q5-based hydrogel and 5% TEC, and a second membrane that included a 10Q5-based hydrogel with a 4-arm PEG epoxide (10 kDa) crosslinker.

FIGS. 9A-9B show microphotographs taken at 1 hour (FIG. 9A) and 24 hours (FIG. 9B), respectively, of a non-carbon backed sensor with a membrane that included a 10Q5-based hydrogel with a 4-arm PEG epoxide (10 kDa) crosslinker and 5% TEC.

FIG. 10 shows graphs of sensitivity/slope (nA/mM) for carbon and non-carbon backed sensors with various 10Q5-based hydrogel membranes, e.g., carbon backed sensors with a 10Q5-based hydrogel membrane with a 4-arm PEG epoxide (10 kDa) crosslinker, carbon backed sensors with a 10Q5-based hydrogel membrane with a 4-arm PEG epoxide (10 kDa) crosslinker and 5% TEC, non-carbon backed sensors with a 10Q5-based hydrogel membrane with a 4-arm PEG epoxide (10 kDa) crosslinker, and non-carbon backed sensors with a 10Q5-based hydrogel membrane with a 4-arm PEG epoxide (10 kDa) crosslinker and 5% TEC.

FIG. 11 shows graphs of average response time (sec) for carbon and non-carbon backed sensors with various 10Q5-based hydrogel membranes, e.g., carbon backed sensors

with a 10Q5-based hydrogel membrane with a 4-arm PEG epoxide (10 kDa) crosslinker, carbon backed sensors with a 10Q5-based hydrogel membrane with a 4-arm PEG epoxide (10 kDa) crosslinker and 5% TEC, non-carbon backed sensors with a 10Q5-based hydrogel membrane with a 4-arm PEG epoxide (10 kDa) crosslinker, and non-carbon backed sensors with a 10Q5-based hydrogel membrane with a 4-arm PEG epoxide (10 kDa) crosslinker and 5% TEC.

FIGS. 12A-12B show top and side view microphotographs, respectively, taken of a non-carbon backed sensor with a membrane that included a hydrogel membrane with a 4-arm PEG epoxide (10 kDa) crosslinker and 1 mg Gly3 before the membrane coated sensors were soaked in PBS.

FIGS. 13A-13C show microphotographs of a non-carbon backed sensor with a membrane that included a hydrogel membrane with a 4-arm PEG epoxide (10 kDa) crosslinker and 1 mg Gly3 taken after the membrane coated sensors were soaked in PBS for 4 hours (FIG. 13A), 4 days (FIG. 13B), and 7 days (FIG. 13C), respectively.

FIGS. 14A-14B show top and side view microphotographs, respectively, taken of a non-carbon backed sensor with a membrane that included a hydrogel membrane with a 4-arm PEG epoxide (10 kDa) crosslinker and 3 mg Gly3 before the membrane coated sensors were soaked in PBS.

FIGS. 15A-15C show microphotographs of a non-carbon backed sensor with a membrane that included a hydrogel membrane with a 4-arm PEG epoxide (10 kDa) crosslinker and 3 mg Gly3 taken after the membrane coated sensors were soaked in PBS for 4 hours (FIG. 15A), 4 days (FIG. 15B), and 7 days (FIG. 15C), respectively.

FIG. 16 shows graphs of sensitivity/slope (nA/mM) for analyte sensors with a hydrogel membrane that included a 4-arm PEG epoxide (10 kDa) crosslinker and either 1 mg or 3 mg triglycetyl glycerol (Gly3).

FIG. 17 shows graphs of average response time (sec) for analyte sensors with a hydrogel membrane that included a 4-arm PEG epoxide (10 kDa) crosslinker and either 1 mg or 3 mg triglycetyl glycerol (Gly3).

FIG. 18 shows a microphotograph of an analyte sensor with a membrane that included a PEG diacrylate (5 kDa) hydrogel taken after soaking in PBS for 30 min.

FIG. 19 shows graphs of sensitivity/slope (nA/mM) for analyte sensors with various PEG diacrylate hydrogel membranes, e.g., sensors with membranes that included: PEG diacrylate (400 Da) and an exit dip speed of 40 mm/sec; PEG diacrylate (400 Da) and an exit dip speed of 60 mm/sec; PEG diacrylate (5 kDa) and an exit dip speed of 30 mm/sec; and PEG diacrylate (5 kDa) and an exit dip speed of 40 mm/sec.

FIG. 20 shows graphs of average response time (sec) for analyte sensors with various PEG diacrylate hydrogel membranes, e.g., sensors with membranes that included: PEG diacrylate (400 Da) and an exit dip speed of 40 mm/sec; PEG diacrylate (400 Da) and an exit dip speed of 60 mm/sec; PEG diacrylate (5 kDa) and an exit dip speed of 30 mm/sec; and PEG diacrylate (5 kDa) and an exit dip speed of 40 mm/sec.

FIG. 21 shows graphs of sensitivity/slope (nA/mM) for analyte sensors with hydrogel membranes that included a 4-arm PEG acrylate crosslinker, e.g., sensors with 1, 2 or 3 coatings of the hydrogel membrane that included a 4-arm PEG acrylate (10 kDa) crosslinker.

FIG. 22 shows graphs of average response time (sec) for analyte sensors with hydrogel membranes that included a 4-arm PEG acrylate crosslinker, e.g., sensors with 1, 2 or 3 coatings of the hydrogel membrane that included a 4-arm PEG acrylate (10 kDa) crosslinker.

FIGS. 23A-23B show microphotographs of an analyte sensor with a membrane that included 1 coating of a PEG triacrylate membrane formulation with 100 mg/ml 4-arm PEG acrylate (10 kDa) crosslinker and trimethylol propane triacrylate (TMPTA) taken after the membrane coated sensor was soaked in PBS for 1 hour (FIG. 23A) and 5 days (FIG. 23B), respectively.

FIGS. 24A-24B show microphotographs of an analyte sensor with a membrane that included 2 coatings of a PEG triacrylate membrane formulation with 100 mg/ml 4-arm PEG acrylate (10 kDa) crosslinker and TMPTA taken after the membrane coated sensor was soaked in PBS for 1 hour (FIG. 24A) and 5 days (FIG. 24B), respectively.

FIGS. 25A-25B show microphotographs of an analyte sensor with a membrane that included 1 coating of a PEG triacrylate membrane formulation with 200 mg/ml 4-arm PEG acrylate (10 kDa) crosslinker and TMPTA taken after the membrane coated sensor was soaked in PBS for 1 hour (FIG. 25A) and 5 days (FIG. 25B), respectively.

FIGS. 26A-26B show microphotographs of an analyte sensor with a membrane that included 2 coatings of a PEG triacrylate membrane formulation with 200 mg/ml 4-arm PEG acrylate (10 kDa) crosslinker and TMPTA taken after the membrane coated sensor was soaked in PBS for 1 hour (FIG. 26A) and 5 days (FIG. 26B), respectively.

#### DETAILED DESCRIPTION

Before the embodiments of the present disclosure are described, it is to be understood that this invention is not limited to particular embodiments described, as such may, of course, vary. It is also to be understood that the terminology used herein is for the purpose of describing particular embodiments only, and is not intended to be limiting, since the scope of the embodiments of the invention will be limited only by the appended claims.

Where a range of values is provided, it is understood that each intervening value, to the tenth of the unit of the lower limit unless the context clearly dictates otherwise, between the upper and lower limits of that range is also specifically disclosed. Each smaller range between any stated value or intervening value in a stated range and any other stated or intervening value in that stated range is encompassed within the invention. The upper and lower limits of these smaller ranges may independently be included or excluded in the range, and each range where either, neither or both limits are included in the smaller ranges is also encompassed within the invention, subject to any specifically excluded limit in the stated range. Where the stated range includes one or both of the limits, ranges excluding either or both of those included limits are also included in the invention.

In the description of the invention herein, it will be understood that a word appearing in the singular encompasses its plural counterpart, and a word appearing in the plural encompasses its singular counterpart, unless implicitly or explicitly understood or stated otherwise. Merely by way of example, reference to "an" or "the" "analyte" encompasses a single analyte, as well as a combination and/or mixture of two or more different analytes, reference to "a" or "the" "concentration value" encompasses a single concentration value, as well as two or more concentration values, and the like, unless implicitly or explicitly understood or stated otherwise. Further, it will be understood that for any given component described herein, any of the possible candidates or alternatives listed for that component, may generally be used individually or in combination with one another, unless implicitly or explicitly understood or

stated otherwise. Additionally, it will be understood that any list of such candidates or alternatives, is merely illustrative, not limiting, unless implicitly or explicitly understood or stated otherwise.

Various terms are described below to facilitate an understanding of the invention. It will be understood that a corresponding description of these various terms applies to corresponding linguistic or grammatical variations or forms of these various terms. It will also be understood that the invention is not limited to the terminology used herein, or the descriptions thereof, for the description of particular embodiments. Merely by way of example, the invention is not limited to particular analytes, bodily or tissue fluids, blood or capillary blood, or sensor constructs or usages, unless implicitly or explicitly understood or stated otherwise, as such may vary.

The publications discussed herein are provided solely for their disclosure prior to the filing date of the application. Nothing herein is to be construed as an admission that the embodiments of the invention are not entitled to antedate such publication by virtue of prior invention. Further, the dates of publication provided may be different from the actual publication dates which may need to be independently confirmed.

#### Hydrogel Membranes

Embodiments of the present disclosure relate to methods and devices for improving the signal response and stability of a sensor by inclusion of a hydrogel membrane, where the components are disposed proximate to a working electrode of the sensor, such as in vivo and/or in vitro analyte sensors, including, such as, continuous and/or automatic in vivo analyte sensors. For example, embodiments of the present disclosure provide for inclusion of a hydrogel membrane in a sensor, resulting in an increase in the stability of the signal from the sensor and an increase in signal response. In certain embodiments, inclusion of the hydrogel membrane results in an increase in the stability of the signal from the sensor and an increase in signal response following insertion of in vivo biosensors in a user and/or during periods of inactivity of the user. Also provided are systems and methods of using the analyte sensors in analyte monitoring.

Embodiments of the present disclosure are based on the discovery that the addition of a hydrogel membrane to in vivo and/or in vitro biosensors improves signal response and stability of the sensor. In general, biocompatible layers of embodiments of the present disclosure can include hydrogels, e.g., polymeric compositions which contain water when in equilibrium with a physiological environment such as living tissue or blood. The hydrogel membrane can be contacted to the sensor as a layer coating the sensor. In certain embodiments, the hydrogel membrane is a first membrane disposed over a sensing layer. In some instances, the hydrogel membrane is a second membrane disposed over a first membrane, which is disposed over a sensing layer.

The hydrogel membrane may include self-polymerizing hydrogels. Self-polymerizing hydrogels are hydrogels that can be formed at room temperature without exposure to external polymerization initiators, such as, but not limited to, heat, light (e.g., ultraviolet (UV) light), or radiation. The monomer precursors of a self-polymerizing hydrogel may polymerize spontaneously in the presence of a polymerization initiator. In some instances, the initiator can be activated by an activating agent. Where desired, the self-polymerizing hydrogels can be formed in situ on a surface of a substrate or disposed over an underlying layer, such as a sensing layer or a membrane layer.

During in vivo use of the subject analyte sensors, a portion of the analyte sensor is inserted beneath a skin surface of a user. Following insertion of the analyte sensor, there may be a transient reduction in signal from the sensor.

This results in variable data quality before the signal from the sensor stabilizes, resulting in a so-called Early Signal Attenuation (ESA) effect. In addition, in some cases, signal response can decrease during periods of inactivity for the user, such as when the user is resting or sleeping, resulting in so-called night time drop-outs.

Embodiments of the hydrogel membranes of the present disclosure provide for increased signal response and stability by decreasing the ESA effect. The result is a reduction, and in some cases, complete elimination of the ESA effect. As such, embodiments of the hydrogel membranes may provide for increased signal response and stability such that substantially no ESA occurs following subcutaneous insertion of the analyte sensor. In some instances, the subject hydrogel membranes provide for increased signal response and stability by decreasing night time drop-outs. The result is a reduction, and in some cases, complete elimination of night time drop-outs. As such, embodiments of the hydrogel membranes may provide for increased signal response and stability such that substantially no night time drop-outs occur.

In embodiments of the present disclosure, the hydrogel includes a crosslinker. A "crosslinker" is a molecule that contains at least two reactive groups capable of linking at least two molecules together, or linking at least two portions of the same molecule together. Linking of at least two molecules is called intermolecular crosslinking, while linking of at least two portions of the same molecule is called intramolecular crosslinking. A crosslinker having more than two reactive groups may be capable of both intermolecular and intramolecular crosslinkings at the same time. In some cases, the crosslinkers react with the heterocyclic nitrogen groups, such as pyridine groups or pyrrolidone groups, or other reactive groups contained on the hydrogel polymer. The crosslinker may include polyethylene glycol or polyethylene glycol derivatives. Examples of polyethylene glycol derivative crosslinkers include, but are not limited to, polyethylene glycol epoxides, polyethylene glycol acrylates, and the like. Thus, the hydrogel membranes of the present disclosure may include a polyethylene glycol (PEG) epoxide crosslinked hydrogel. In some cases, the hydrogel membranes of the present disclosure include a polyethylene glycol (PEG) acrylate crosslinked hydrogel.

The hydrogel (e.g., the PEG epoxide crosslinked hydrogel or the PEG acrylate crosslinked hydrogel) may be formulated with one or more layers of a sensor, e.g., a membrane that is disposed over at least a portion of the sensing layer of the working electrode, or a second membrane that is disposed over at least a portion of a first membrane that is disposed over at least a portion of the sensing layer of the working electrode. Any suitable proportion of hydrogel may be used with such one or more layers, where the specifics will depend on, e.g., the particular layer, etc.

#### Polyethylene Glycol Epoxide Crosslinked Hydrogels

Examples of hydrogels suitable for use with the subject methods, compositions and kits include, but are not limited to, heterocyclic nitrogen-containing polymer hydrogels. In some instances, the heterocyclic nitrogen group includes groups such as, but not limited to, pyridine, pyrrole, pyrrolidine, pyrrolidone, imidazole, oxazole, thiazole, pyrazole, or any derivative thereof. In certain cases, the heterocyclic nitrogen groups are independently vinylpyridine, such as 2-, 3-, or 4-vinylpyridine, or vinylimidazole, such as 1-, 2-, or

4-vinylimidazole. In some instances, the heterocyclic nitrogen groups are independently 4-vinylpyridine, such as poly(4-vinylpyridine), or derivatives thereof. In certain embodiments, the hydrogel includes Formulation 10Q5, as shown below.

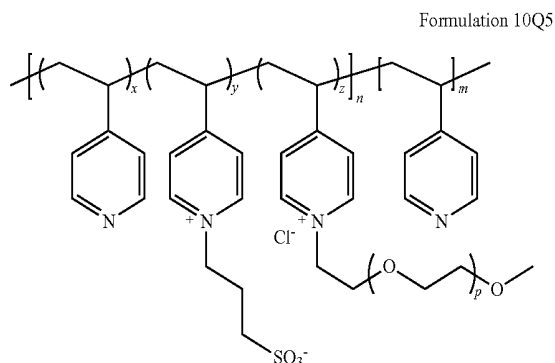

where  $x=0.85$ ,  $y=0.1$ ,  $z=0.05$ ,  $n=9$ ,  $m=1$ , and  $p$ =about 10.

Formulation 10Q5 is described in U.S. patent application Ser. No. 11/734,272, the disclosure of which is incorporated herein by reference in its entirety.

In certain embodiments, the heterocyclic nitrogen-containing polymer hydrogels can include heterocyclic nitrogen groups that are independently vinylpyrrolidone, such as N-vinylpyrrolidone. In some cases, the heterocyclic nitrogen groups are independently polyvinylpyrrolidone (PVP).

In certain embodiments, the hydrogel membrane can include a crosslinker. For example, the hydrogel may include a polyethylene glycol (PEG) epoxide crosslinker, such as, but not limited to, a 2-arm polyethylene glycol epoxide crosslinker, a 4-arm polyethylene glycol epoxide crosslinker, mixtures thereof, and the like. The 2-arm polyethylene glycol epoxide crosslinker may have a molecular weight ranging from 400 to 50,000 Da, such as from 700 to 30,000 Da, including from 1,000 to 20,000 Da. For instance, the 2-arm polyethylene glycol epoxide crosslinker can have a molecular weight of 5,000 Da, 10,000 Da, or 20,000 Da, etc. In some embodiments, the 4-arm polyethylene glycol epoxide crosslinker has a molecular weight ranging from 400 to 50,000 Da, such as from 700 to 30,000 Da, including from 1,000 to 20,000 Da. For instance, the 4-arm polyethylene glycol epoxide crosslinker can have a molecular weight of 5,000 Da, 10,000 Da, or 20,000 Da, etc. Where desired, the hydrogel may include from about 1% (w/v) to about 5% (w/v) PEG epoxide crosslinker, such as from about 1.5% (w/v) to about 4% (w/v) PEG epoxide crosslinker, including from about 1.75% (w/v) to about 3% (w/v) PEG epoxide crosslinker. In certain embodiments, the hydrogel will include about 1.7% (w/v) PEG epoxide crosslinker.

In certain embodiments, the PEG epoxide crosslinked hydrogel may comprise from 1% to 40% (w/v) of the total biosensor membrane formulation. For example, such PEG epoxide crosslinked hydrogels may comprise from 1% to 30% (w/v) of the total biosensor membrane formulation, including, for example, from 1% to 20% (w/v), from 1% to 10% (w/v), from 5% to 10% (w/v), and the like. Where desired, the biosensor membrane formulation may include 1% (w/v) or more PEG epoxide crosslinked hydrogel, such as 5% (w/v) or more, including 10% (w/v) or more.

Embodiments of the PEG epoxide crosslinked hydrogels may include a swelling modulator. In certain cases, the swelling modulator is a water absorption mediator, e.g., the

swelling modulator controls the amount of water uptake and/or retention by the hydrogel. Thus, the swelling modulator may facilitate a reduction in the rate and/or amount of water absorbed by the membrane layer of the sensors.

5 Examples of swelling modulators include, but are not limited to, 3-arm epoxides, and the like. For instance, the swelling modulator can be a non-PEG 3-arm epoxide, i.e., a 3-arm epoxide that does not include PEG. In some instances, the swelling modulator includes, but is not limited to, a non-PEG 3-arm epoxide, such as triglycedyl glycerol, and the like. Where desired, the PEG epoxide crosslinked hydrogel may include from about 0.01% (w/v) to about 0.09% (w/v) swelling modulator, such as from about 0.02% (w/v) to about 0.08% (w/v) swelling modulator, including from about 0.03% (w/v) to about 0.07% (w/v) swelling modulator, and from about 0.04% (w/v) to about 0.06% (w/v) swelling modulator.

Any suitable proportion of swelling modulator may be used with the PEG epoxide crosslinked hydrogel membrane, where the specifics will depend on, e.g., the particular hydrogel membrane, etc. In certain embodiments, the swelling modulator may comprise from 0.001% to 10% (w/v) of the total biosensor membrane formulation. For instance, such swelling modulators may comprise from 0.001% to 5% (w/v) of the total PEG epoxide crosslinked hydrogel membrane formulation, including, for example, from 0.01% to 5% (w/v), from 0.01% to 3% (w/v), from 0.01% to 1% (w/v), from 0.05% to 1% (w/v), from 0.05% to 0.5% (w/v), from 0.05% to 0.25% (w/v), from 0.05% to 0.15% (w/v), and the like. In some cases, the PEG epoxide crosslinked hydrogel membrane formulation includes 0.01% (w/v) or more swelling modulator, such as 0.05% (w/v) or more, including 0.1% (w/v) or more, for instance 0.15% (w/v) or more swelling modulator.

Embodiments of the PEG epoxide crosslinked hydrogel may also include a plasticizer. In certain embodiments, the plasticizer can include, but is not limited to, triethyl citrate (TEC), dibutyl sebacate, polyethylene glycol and polypropylene glycol, dibutyl phthalate, diethyl phthalate, tributyl citrate, acetylated monoglyceride, acetyl tributyl citrate, triacetin, dimethyl phthalate, benzyl benzoate, butyl and/or glycol esters of fatty acids, refined mineral oils, oleic acid, castor oil, corn oil, camphor, glycerol, sorbitol, combinations thereof, and the like. The plasticizer may comprise from 0.1% to 150% (w/v) of the total PEG epoxide crosslinked hydrogel membrane formulation, including, for example, from 0.1% to 10% (w/v), from 1% to 10% (w/v), from 1% to 5% (w/v), and the like. Where desired, the PEG epoxide crosslinked hydrogel membrane formulation can include 5% (w/v) plasticizer. For example, the PEG epoxide crosslinked hydrogel membrane formulation can include about 3% or about 5% TEC.

#### Polyethylene Glycol Acrylate Crosslinked Hydrogels

55 Additional examples of hydrogels suitable for use with the subject methods, compositions and kits include self-polymerizing hydrogels. As described above, self-polymerizing hydrogels are hydrogels that can be formed in situ at room temperature without exposure to external polymerization initiators, such as, but not limited to, heat, light (e.g., ultraviolet (UV) light), or radiation. The polymerization of monomer precursors of self-polymerizing hydrogels can occur by free-radical polymerization begun by contacting hydrogel precursors (e.g., hydrogel monomers) with an initiator. In some cases, the initiator can be contacted with an activating agent to activate the initiator to begin polymerization of the hydrogel.

In certain embodiments, the self-polymerizing hydrogels include, but are not limited to, polyethylene glycol hydrogels or polyethylene glycol derivative hydrogels. Examples of self-polymerizing hydrogels that may find use in the present disclosure include, but are not limited to, polyethylene glycol diacrylate, polyethylene glycol triacrylate, polyethylene glycol acrylate, polyethylene glycol, combinations thereof, and the like. Where desired, the self-polymerizing hydrogel includes polyethylene glycol triacrylate. In some instances, the self-polymerizing hydrogel includes polyethylene glycol diacrylate.

The self-polymerizing hydrogel may include an initiator and an activating agent. In these cases, the hydrogel precursors can be contacted with the initiator and the activating agent to begin polymerization to form the hydrogel. For example, in some cases, the hydrogel precursors, the initiator and the activating agent are contacted with each other in situ to form the self-polymerizing hydrogel on a surface of a substrate. Examples of initiators suitable for use with the subject methods, compositions and kits include, but are not limited to, peroxides, such as hydrogen peroxide, and the like. In some cases, the self-polymerizing hydrogel formulation includes from about 1% (w/v) to about 5% (w/v) initiator, such as from about 2% (w/v) to about 4% (w/v) initiator, including from about 3.4% (w/v) to about 3.8% (w/v) initiator. Examples of activating agents suitable for use with the subject methods, compositions and kits include, but are not limited to, metallic salts, such as ferrous gluconate, and the like. In some cases, the self-polymerizing hydrogel formulation includes from about 1% (w/v) to about 10% (w/v) activating agent, such as from about 2% (w/v) to about 8% (w/v) activating agent, including from about 4% (w/v) to about 6% (w/v) activating agent.

In embodiments of the present disclosure, the hydrogel includes a crosslinker. In certain instances, the crosslinker includes polyethylene glycol or polyethylene glycol derivatives. Examples of polyethylene glycol derivatives include, but are not limited to, polyethylene glycol (PEG) acrylates. Thus, in some cases, the hydrogel includes a PEG acrylate crosslinked hydrogel. PEG acrylate crosslinkers that may find use in the subject hydrogels include, but are not limited to, 2-arm polyethylene glycol acrylate crosslinkers, 4-arm polyethylene glycol acrylate crosslinkers, mixtures thereof, and the like. In certain embodiments, the 2-arm polyethylene glycol acrylate crosslinker has a molecular weight ranging from 400 to 50,000 Da, such as from 700 to 30,000 Da, including from 1,000 to 20,000 Da. For instance, the 2-arm polyethylene glycol acrylate crosslinker can have a molecular weight of 5,000 Da, 10,000 Da, or 20,000 Da, etc. In some embodiments, the 4-arm polyethylene glycol acrylate crosslinker has a molecular weight ranging from 400 to 50,000 Da, such as from 700 to 30,000 Da, including from 1,000 to 20,000 Da. For instance, the 4-arm polyethylene glycol acrylate crosslinker can have a molecular weight of 5,000 Da, 10,000 Da, or 20,000 Da, etc. Where desired, the hydrogel may include from about 1% (w/v) to about 20% (w/v) PEG acrylate crosslinker, such as from about 2% (w/v) to about 18% (w/v) PEG acrylate crosslinker, including from about 4% (w/v) to about 16% (w/v) PEG acrylate crosslinker, from about 6% (w/v) to about 14% (w/v) PEG acrylate crosslinker, from about 8% (w/v) to about 12% (w/v) PEG acrylate crosslinker. In certain embodiments, the hydrogel may include about 10% (w/v) PEG acrylate crosslinker.

In some instances, the PEG acrylate crosslinked hydrogel comprises from 1% to 40% (w/v) of the total biosensor membrane formulation. For example, such PEG acrylate

crosslinked hydrogels may comprise from 1% to 30% (w/v) of the total biosensor membrane formulation, including, for example, from 1% to 20% (w/v), from 5% to 20% (w/v), from 10% to 20% (w/v), and the like. In some cases, the biosensor membrane formulation includes 1% (w/v) or more PEG acrylate crosslinked hydrogel, such as 5% (w/v) or more, including 10% (w/v) or more, for example 20% (w/v) or more.

The PEG acrylate crosslinked hydrogel may include a swelling modulator. In some cases, the swelling modulator is a water absorption mediator. Thus, the swelling modulator may facilitate a reduction in the rate and/or amount of water absorbed by the membrane layer of the sensors. Examples of swelling modulators include, but are not limited to, 3-arm acrylates, and the like. For instance, the swelling modulator can be a non-PEG 3-arm acrylate, i.e., a 3-arm acrylate that does not include PEG. Where desired, the swelling modulator can include, but is not limited to, a non-PEG 3-arm acrylate, such as trimethylol propane triacrylate, and the like. In certain embodiments, the PEG acrylate crosslinked hydrogel includes from about 0.05% (w/v) to about 7.5% (w/v) swelling modulator, such as from about 1% (w/v) to about 7% (w/v) swelling modulator, including from about 1.5% (w/v) to about 6.5% (w/v) swelling modulator, from about 2% (w/v) to about 5% (w/v) swelling modulator, from about 3% (w/v) to about 4% (w/v) swelling modulator.

Any suitable proportion of swelling modulator may be used with the PEG acrylate crosslinked hydrogel membrane, where the specifics will depend on, e.g., the particular hydrogel membrane, etc. In certain embodiments, the swelling modulator may comprise from 0.001% to 10% (w/v) of the total biosensor membrane formulation. For example, the swelling modulator may comprise from 0.001% to 5% (w/v) of the total PEG acrylate crosslinked hydrogel membrane formulation, including, for example, from 0.01% to 5% (w/v), from 0.01% to 3% (w/v), from 0.01% to 1% (w/v), from 0.05% to 1% (w/v), from 0.05% to 0.5% (w/v), from 0.05% to 0.25% (w/v), from 0.05% to 0.20% (w/v), and the like. In some cases, the PEG acrylate crosslinked hydrogel membrane formulation includes 0.01% (w/v) or more swelling modulator, such as 0.05% (w/v) or more, including 0.1% (w/v) or more, for instance 0.15% (w/v) or more, or 0.20% (w/v) or more.

In certain embodiments, the hydrogel is a degradable hydrogel, i.e., a hydrogel that degrades (e.g., dissolves) when soaked in solution or inserted within the body over time. For example, the hydrogel may be a degradable hydrogel that degrades in the body over a period of 1 hour or more, such as 4 hours or more, 8 hours or more, including 0.5 days or more, 1 day or more, 2 days or more, 4 days or more, 7 days or more, 10 days or more 14 days or more, or 1 month or more, etc.

The self-polymerizing hydrogel may be formulated as two or more compositions, where the two or more compositions are contacted with each other in situ to form the self-polymerizing hydrogel layer. In some cases, the self-polymerizing hydrogel layer is formulated as a first composition and a second composition, where the first composition is first contacted with the underlying sensing layer or first membrane layer and then the second composition is contacted with the first composition to form the self-polymerizing hydrogel layer in situ. In certain embodiments, the first composition includes a hydrogel monomer and an activating agent. For example, the first composition can include a hydrogel monomer, such as polyethylene glycol triacrylate, and an activating agent, such as ferrous gluconate. In some instances, the first composition further includes a solvent,

such as, but not limited to, phosphate buffered saline (PBS). Embodiments of the second composition can include an initiator, including, but not limited to, a peroxide, such as hydrogen peroxide. In some instances, the second composition can also include, a glucose responsive enzyme (e.g., glucose oxidase, glucose dehydrogenase, etc.), and a redox mediator. In other embodiments, the first composition can include the initiator, such as hydrogen peroxide, and the second composition can include the hydrogel monomer, such as polyethylene glycol triacrylate, and an activating agent, such as ferrous gluconate.

#### Systems and Methods Using Hydrogel Membranes

As indicated above, the hydrogels of the present disclosure (e.g., PEG epoxide crosslinked hydrogel or PEG acrylate crosslinked hydrogel) may be included in a membrane layer of a sensor, such as a second membrane disposed over a first membrane. The second membrane formulation of a sensor can be contacted to the sensor (e.g., by dip coating, spray coating, drop deposition, and the like) and cured. In some instances, the second membrane may form one or more bonds with the underlying first membrane. By bonds is meant any type of an interaction between atoms or molecules that allows chemical compounds to form associations with each other, such as, but not limited to, covalent bonds, ionic bonds, dipole-dipole interactions, hydrogen bonds, London dispersion forces, and the like. For example, in situ polymerization of the second membrane can form crosslinks between the polymers of the second membrane and the polymers in the underlying first membrane. In certain embodiments, crosslinking of the second membrane to the first membrane facilitates a reduction in the occurrence of delamination of the second membrane from the first membrane.

Similarly, in certain embodiments, the first membrane may form one or more bonds with the underlying sensing layer. For example, in situ polymerization of the first membrane can form crosslinks between the polymers of the first membrane and the polymers in the underlying sensing layer. In certain embodiments, crosslinking of the first membrane to the sensing layer facilitates a reduction in the occurrence of delamination of the first membrane from the sensing layer.

Additional embodiments of a sensor that may be formulated with hydrogels of the present disclosure are described in U.S. Pat. Nos. 5,262,035, 5,262,305, 6,134,461, 6,143,164, 6,175,752, 6,338,790, 6,579,690, 6,654,625, 6,736,957, 6,746,582, 6,932,894, 6,605,200, 6,605,201, 7,090,756, 6,746,582 as well as those described in U.S. patent application Ser. Nos. 11/701,138, 11/948,915, all of which are incorporated herein by reference in their entirety.

In some embodiments, the hydrogel of the present disclosure is formulated with a membrane layer that is disposed proximate to the working electrode, for instance as a second membrane disposed over a first membrane, which is disposed over a sensing layer. Generally, an embodiment of a sensing layer may be described as the area shown schematically in FIG. 5B as 508. The sensing layer may be described as the active chemical area of the biosensor. The sensing layer formulation, which can include a glucose-transducing agent, may include, for example, among other constituents, a redox mediator, such as, for example, a hydrogen peroxide or a transition metal complex, such as a ruthenium-containing complex or an osmium-containing complex, and an analyte response enzyme, such as, for example, a glucose responsive enzyme (e.g., glucose oxidase, glucose dehydrogenase, etc.) or lactate responsive enzyme (e.g., lactate oxidase). The sensing layer may also include other optional

components, such as, for example, a polymer and a bi-functional, short-chain, epoxide cross-linker, such as polyethylene glycol (PEG).

In an electrochemical embodiment, the sensor is placed, transcutaneously, for example, into a subcutaneous site such that subcutaneous fluid of the site comes into contact with the sensor. In other in vivo embodiments, placement of at least a portion of the sensor may be in a blood vessel. The sensor operates to electrolyze an analyte of interest in the subcutaneous fluid such that a current is generated between the working electrode and the counter electrode. A value for the current associated with the working electrode is determined. If multiple working electrodes are used, current values from each of the working electrodes may be determined. A microprocessor may be used to collect these periodically determined current values or to further process these values.

If an analyte concentration is successfully determined, it may be displayed, stored, and/or otherwise processed to provide useful information. By way of example, raw signal or analyte concentrations may be used as a basis for determining a rate of change in analyte concentration, which should not change at a rate greater than a predetermined threshold amount. If the rate of change of analyte concentration exceeds the predefined threshold, an indication may be displayed or otherwise transmitted to indicate this fact.

As demonstrated herein, the methods of the present disclosure are useful in connection with a device that is used to measure or monitor a glucose analyte, such as any such device described herein. These methods may also be used in connection with a device that is used to measure or monitor another analyte, including oxygen, carbon dioxide, proteins, drugs, or another moiety of interest, for example, or any combination thereof, in bodily fluid, including subcutaneous fluid, dermal fluid (sweat, tears, and the like), interstitial fluid, or other bodily fluid of interest, for example, or any combination thereof. In general, the device is in good contact, such as thorough and substantially continuous contact, with the bodily fluid.

According to embodiments of the present disclosure, the measurement sensor is one suited for electrochemical measurement of analyte concentration, such as, for example, glucose concentration, in a bodily fluid. In this embodiment, the measurement sensor comprises at least a working electrode and a counter electrode. Other embodiments may further comprise a reference electrode. The working electrode is typically associated with a glucose-responsive enzyme. A mediator may also be included. In certain embodiments, hydrogen peroxide, which may be characterized as a mediator, is produced by a reaction of the sensor and may be used to infer the concentration of glucose. In some embodiments, a mediator is added to the sensor by a manufacturer, i.e., is included with the sensor even prior to use. Generally, a redox mediator is relative to the working electrode and is capable of transferring electrons between a compound and a working electrode, either directly or indirectly. Merely by way of example, the redox mediator may be, and is, for example, immobilized on the working electrode, e.g., entrapped on a surface or chemically bound to a surface.

#### Electrochemical Sensors

Embodiments of the present disclosure relate to methods and devices for detecting at least one analyte, including glucose, in body fluid. Embodiments relate to the continuous and/or automatic in vivo monitoring of the level of one or more analytes using a continuous analyte monitoring system

that includes an analyte sensor at least a portion of which is to be positioned beneath a skin surface of a user for a period of time and/or the discrete monitoring of one or more analytes using an in vitro blood glucose ("BG") meter and an analyte test strip. Embodiments include combined or combinable devices, systems and methods and/or transferring data between an in vivo continuous system and an in vivo system. In some embodiments, the systems, or at least a portion of the systems, are integrated into a single unit.

A sensor that includes a hydrogel membrane of the present disclosure may be an in vivo sensor or an in vitro sensor (i.e., a discrete monitoring test strip). Such a sensor can be formed on a substrate, e.g., a substantially planar substrate. In certain embodiments, such a sensor is a wire, e.g., a working electrode wire inner portion with one or more other electrodes associated (e.g., on, including wrapped around) therewith. The sensor may also include at least one counter electrode (or counter/reference electrode) and/or at least one reference electrode or at least one reference/counter electrode.

Accordingly, embodiments include analyte monitoring devices and systems that include an analyte sensor at least a portion of which is positionable beneath the skin surface of the user for the in vivo detection of an analyte, including glucose, lactate, and the like, in a body fluid. Embodiments include wholly implantable analyte sensors and analyte sensors in which only a portion of the sensor is positioned under the skin and a portion of the sensor resides above the skin, e.g., for contact to a sensor control unit (which may include a transmitter), a receiver/display unit, transceiver, processor, etc. The sensor may be, for example, subcutaneously positionable in a user for the continuous or periodic monitoring of a level of an analyte in the user's interstitial fluid. For the purposes of this description, continuous monitoring and periodic monitoring will be used interchangeably, unless noted otherwise. The sensor response may be correlated and/or converted to analyte levels in blood or other fluids. In certain embodiments, an analyte sensor may be positioned in contact with interstitial fluid to detect the level of glucose, which detected glucose may be used to infer the glucose level in the user's bloodstream. Analyte sensors may be insertable into a vein, artery, or other portion of the body containing fluid. Embodiments of the analyte sensors of the subject disclosure having a hydrogel membrane may be configured for monitoring the level of the analyte over a time period which may range from seconds, minutes, hours, days, weeks, to months, or longer.

In certain embodiments, the analyte sensors, such as glucose sensors, have a self-polymerizing hydrogel and are capable of in vivo detection of an analyte for about one hour or more, e.g., about a few hours or more, e.g., about a few days or more, e.g., about three or more days, e.g., about five days or more, e.g., about seven days or more, e.g., about several weeks or at least one month or more. Future analyte levels may be predicted based on information obtained, e.g., the current analyte level at time  $t_0$ , the rate of change of the analyte, etc. Predictive alarms may notify the user of a predicted analyte levels that may be of concern in advance of the user's analyte level reaching the future level. This provides the user an opportunity to take corrective action.

FIG. 1 shows a data monitoring and management system such as, for example, an analyte (e.g., glucose) monitoring system 100 in accordance with certain embodiments. Embodiments of the subject disclosure are further described primarily with respect to glucose monitoring devices and systems, and methods of glucose detection, for convenience only and such description is in no way intended to limit the

scope of the present disclosure. It is to be understood that the analyte monitoring system may be configured to monitor a variety of analytes at the same time or at different times.

Analytes that may be monitored include, but are not limited to, acetyl choline, amylase, bilirubin, cholesterol, chorionic gonadotropin, creatine kinase (e.g., CK-MB), creatine, creatinine, DNA, fructosamine, glucose, glutamine, growth hormones, hormones, ketone bodies, lactate, peroxide, prostate-specific antigen, prothrombin, RNA, thyroid stimulating hormone, and troponin. The concentration of drugs, such as, for example, antibiotics (e.g., gentamicin, vancomycin, and the like), digitoxin, digoxin, drugs of abuse, theophylline, and warfarin, may also be monitored. In embodiments that monitor more than one analyte, the analytes may be monitored at the same or different times.

The analyte monitoring system 100 includes an analyte sensor 101, a data processing unit 102 connectable to the sensor 101, and a primary receiver unit 104. In some instances, the primary receiver unit 104 is configured to communicate with the data processing unit 102 via a communication link 103. In certain embodiments, the primary receiver unit 104 may be further configured to transmit data to a data processing terminal 105 to evaluate or otherwise process or format data received by the primary receiver unit 104. The data processing terminal 105 may be configured to receive data directly from the data processing unit 102 via a communication link 107, which may optionally be configured for bi-directional communication. Further, the data processing unit 102 may include a transmitter or a transceiver to transmit and/or receive data to and/or from the primary receiver unit 104 and/or the data processing terminal 105 and/or optionally a secondary receiver unit 106.

Also shown in FIG. 1 is an optional secondary receiver unit 106 which is operatively coupled to the communication link 103 and configured to receive data transmitted from the data processing unit 102. The secondary receiver unit 106 may be configured to communicate with the primary receiver unit 104, as well as the data processing terminal 105. In certain embodiments, the secondary receiver unit 106 may be configured for bi-directional wireless communication with each of the primary receiver unit 104 and the data processing terminal 105. As discussed in further detail below, in some instances, the secondary receiver unit 106 may be a de-featured receiver as compared to the primary receiver unit 104, i.e., the secondary receiver unit 106 may include a limited or minimal number of functions and features as compared with the primary receiver unit 104. As such, the secondary receiver unit 106 may include a smaller (in one or more, including all, dimensions), compact housing or embodied in a device including a wrist watch, arm band, PDA, mp3 player, cell phone, etc., for example. Alternatively, the secondary receiver unit 106 may be configured with the same or substantially similar functions and features as the primary receiver unit 104. The secondary receiver unit 106 may include a docking portion configured to mate with a docking cradle unit for placement by, e.g., the bedside for night time monitoring, and/or a bi-directional communication device. A docking cradle may recharge a power supply.

Only one analyte sensor 101, data processing unit 102 and data processing terminal 105 are shown in the embodiment of the analyte monitoring system 100 illustrated in FIG. 1. However, it will be appreciated by one of ordinary skill in the art that the analyte monitoring system 100 may include more than one sensor 101 and/or more than one data processing unit 102, and/or more than one data processing terminal 105. Multiple sensors may be positioned in a user

for analyte monitoring at the same or different times. In certain embodiments, analyte information obtained by a first sensor positioned in a user may be employed as a comparison to analyte information obtained by a second sensor. This may be useful to confirm or validate analyte information obtained from one or both of the sensors. Such redundancy may be useful if analyte information is contemplated in critical therapy-related decisions. In certain embodiments, a first sensor may be used to calibrate a second sensor.

The analyte monitoring system **100** may be a continuous monitoring system, or semi-continuous, or a discrete monitoring system. In a multi-component environment, each component may be configured to be uniquely identified by one or more of the other components in the system so that communication conflict may be readily resolved between the various components within the analyte monitoring system **100**. For example, unique IDs, communication channels, and the like, may be used.

In certain embodiments, the sensor **101** is physically positioned in or on the body of a user whose analyte level is being monitored. The sensor **101** may be configured to at least periodically sample the analyte level of the user and convert the sampled analyte level into a corresponding signal for transmission by the data processing unit **102**. The data processing unit **102** is coupleable to the sensor **101** so that both devices are positioned in or on the user's body, with at least a portion of the analyte sensor **101** positioned transcutaneously. The data processing unit may include a fixation element such as an adhesive or the like to secure it to the user's body. A mount (not shown) attachable to the user and mateable with the data processing unit **102** may be used. For example, a mount may include an adhesive surface. The data processing unit **102** performs data processing functions, where such functions may include but are not limited to, filtering and encoding of data signals, each of which corresponds to a sampled analyte level of the user, for transmission to the primary receiver unit **104** via the communication link **103**. In one embodiment, the sensor **101** or the data processing unit **102** or a combined sensor/data processing unit may be wholly implantable under the skin surface of the user.

In certain embodiments, the primary receiver unit **104** may include an analog interface section including an RF receiver and an antenna that is configured to communicate with the data processing unit **102** via the communication link **103**, and a data processing section for processing the received data from the data processing unit **102** including data decoding, error detection and correction, data clock generation, data bit recovery, etc., or any combination thereof.

In operation, the primary receiver unit **104** in certain embodiments is configured to synchronize with the data processing unit **102** to uniquely identify the data processing unit **102**, based on, for example, an identification information of the data processing unit **102**, and thereafter, to periodically receive signals transmitted from the data processing unit **102** associated with the monitored analyte levels detected by the sensor **101**.

Referring again to FIG. 1, the data processing terminal **105** may include a personal computer, a portable computer including a laptop or a handheld device (e.g., a personal digital assistant (PDAs, a telephone including a cellular phone (e.g., a multimedia and Internet-enabled mobile phone including an iPhone™, a Blackberry®, or similar phone), an mp3 player (e.g., an iPOD™, etc.), a pager, and the like), and/or a drug delivery device (e.g., an infusion pump), each of which may be configured for data commu-

nication with the receiver via a wired or a wireless connection. Additionally, the data processing terminal **105** may further be connected to a data network (not shown) for storing, retrieving, updating, and/or analyzing data corresponding to the detected analyte level of the user.

The data processing terminal **105** may include an infusion device such as an insulin infusion pump or the like, which may be configured to administer insulin to the user, and which may be configured to communicate with the primary receiver unit **104** for receiving, among others, the measured analyte level. Alternatively, the primary receiver unit **104** may be configured to integrate an infusion device therein so that the primary receiver unit **104** is configured to administer an appropriate drug (e.g., insulin) to users, for example, for administering and modifying basal profiles, as well as for determining appropriate boluses for administration based on, among others, the detected analyte levels received from the data processing unit **102**. An infusion device may be an external device or an internal device (wholly implantable in a user).

In certain embodiments, the data processing terminal **105**, which may include an infusion device, e.g., an insulin pump, may be configured to receive the analyte signals from the data processing unit **102**, and thus, incorporate the functions of the primary receiver unit **104** including data processing for managing the user's insulin therapy and analyte monitoring. In certain embodiments, the communication link **103**, as well as one or more of the other communication interfaces shown in FIG. 1, may use one or more of: an RF communication protocol, an infrared communication protocol, a Bluetooth enabled communication protocol, an 802.11x wireless communication protocol, or an equivalent wireless communication protocol which would allow secure, wireless communication of several units (for example, per Health Insurance Portability and Accountability Act (HIPPA) requirements), while avoiding potential data collision and interference.

FIG. 2 shows a block diagram of an embodiment of a data processing unit **102** of the analyte monitoring system shown in FIG. 1. User input and/or interface components may be included or a data processing unit may be free of user input and/or interface components. In certain embodiments, one or more application-specific integrated circuits (ASIC) may be used to implement one or more functions or routines associated with the operations of the data processing unit (and/or receiver unit) using for example one or more state machines and buffers.

As can be seen in the embodiment of FIG. 2, the analyte sensor **101** (FIG. 1) includes four contacts, three of which are electrodes: a work electrode (W) **210**, a reference electrode (R) **212**, and a counter electrode (C) **213**, each operatively coupled to the analog interface **201** of the data processing unit **102**. This embodiment also shows an optional guard contact (G) **211**. Fewer or greater electrodes may be employed. For example, the counter and reference electrode functions may be served by a single counter/reference electrode. In some cases, there may be more than one working electrode and/or reference electrode and/or counter electrode, etc.

FIG. 3 is a block diagram of an embodiment of a receiver/monitor unit such as the primary receiver unit **104** of the analyte monitoring system shown in FIG. 1. The primary receiver unit **104** includes one or more of: a test strip interface **301**, an RF receiver **302**, a user input **303**, a temperature detection section **304**, and a clock **305**, each of which is operatively coupled to a processing and storage section **307**. The primary receiver unit **104** also includes a

power supply **306** operatively coupled to a power conversion and monitoring section **308**. Further, the power conversion and monitoring section **308** is also coupled to the processing and storage section **307**. Moreover, also shown are a receiver serial communication section **309**, and an output **310**, each operatively coupled to the processing and storage section **307**. The primary receiver unit **104** may include user input and/or interface components or may be free of user input and/or interface components.

In certain embodiments, the test strip interface **301** includes a glucose level testing portion to receive a blood (or other body fluid sample) glucose test or information related thereto. For example, the test strip interface **301** may include a test strip port to receive a glucose test strip. The device may determine the glucose level of the test strip, and optionally display (or otherwise notice) the glucose level on the output **310** of the primary receiver unit **104**. Any suitable test strip may be employed, e.g., test strips that only require a very small amount (e.g., 3 microliters or less, e.g., 1 microliter or less, e.g., 0.5 microliters or less, e.g., 0.1 microliters or less), of applied sample to the strip in order to obtain accurate glucose information. Embodiments of test strips include, e.g., FreeStyle® blood glucose test strips from Abbott Diabetes Care, Inc. (Alameda, Calif.). Glucose information obtained by the in vitro glucose testing device may be used for a variety of purposes, computations, etc. For example, the information may be used to calibrate sensor **101**, confirm results of sensor **101** to increase the confidence thereof (e.g., in instances in which information obtained by sensor **101** is employed in therapy related decisions), etc.

In further embodiments, the data processing unit **102** and/or the primary receiver unit **104** and/or the secondary receiver unit **106**, and/or the data processing terminal/infusion device **105** may be configured to receive the blood glucose value wirelessly over a communication link from, for example, a blood glucose meter. In further embodiments, a user manipulating or using the analyte monitoring system **100** (FIG. 1) may manually input the blood glucose value using, for example, a user interface (for example, a keyboard, keypad, voice commands, and the like) incorporated in one or more of the data processing unit **102**, the primary receiver unit **104**, secondary receiver unit **106**, or the data processing terminal/infusion device **105**.

Additional detailed descriptions are provided in U.S. Pat. Nos. 5,262,035; 5,264,104; 5,262,305; 5,320,715; 5,593,852; 6,175,752; 6,650,471; 6,746,582, and in application Ser. No. 10/745,878 filed Dec. 26, 2003 entitled "Continuous Glucose Monitoring System and Methods of Use", each of which is incorporated herein by reference in their entirety.

FIG. 4 schematically shows an embodiment of an analyte sensor **400** in accordance with the embodiments of the present disclosure. This sensor embodiment includes electrodes **401**, **402** and **403** on a base **404**. Electrodes (and/or other features) may be applied or otherwise processed using any suitable technology, e.g., chemical vapor deposition (CVD), physical vapor deposition, sputtering, reactive sputtering, printing, coating, ablating (e.g., laser ablation), painting, dip coating, etching, and the like. Materials include, but are not limited to, any one or more of aluminum, carbon (including graphite), cobalt, copper, gallium, gold, indium, iridium, iron, lead, magnesium, mercury (as an amalgam), nickel, niobium, osmium, palladium, platinum, rhenium, rhodium, selenium, silicon (e.g., doped polycrystalline silicon), silver, tantalum, tin, titanium, tungsten, uranium, vanadium, zinc, zirconium, mixtures thereof, and alloys, oxides, or metallic compounds of these elements.

The analyte sensor **400** may be wholly implantable in a user or may be configured so that only a portion is positioned within (internal) a user and another portion outside (external) a user. For example, the sensor **400** may include a first portion positionable above a surface of the skin **410**, and a second portion positioned below the surface of the skin. In such embodiments, the external portion may include contacts (connected to respective electrodes of the second portion by traces) to connect to another device also external to the user such as a transmitter unit. While the embodiment of FIG. 4 shows three electrodes side-by-side on the same surface of base **404**, other configurations are contemplated, e.g., fewer or greater electrodes, some or all electrodes on different surfaces of the base or present on another base, some or all electrodes stacked together, electrodes of differing materials and dimensions, etc.

FIG. 5A shows a perspective view of an embodiment of an analyte sensor **500** having a first portion (which in this embodiment may be characterized as a major portion) positionable above a surface of the skin **510**, and a second portion (which in this embodiment may be characterized as a minor portion) that includes an insertion tip **530** positionable below the surface of the skin, e.g., penetrating through the skin and into, e.g., the subcutaneous space **520**, in contact with the user's biofluid such as interstitial fluid. Contact portions of a working electrode **511**, a reference electrode **512**, and a counter electrode **513** are positioned on the first portion of the sensor **500** situated above the skin surface **510**. A working electrode **501**, a reference electrode **502**, and a counter electrode **503** are shown at the second portion of the sensor **500** and particularly at the insertion tip **530**. Traces may be provided from the electrodes at the tip to the contact, as shown in FIG. 5A. It is to be understood that greater or fewer electrodes may be provided on a sensor. For example, a sensor may include more than one working electrode and/or the counter and reference electrodes may be a single counter/reference electrode, etc.

FIG. 5B shows a cross sectional view of a portion of the sensor **500** of FIG. 5A. The electrodes **501**, **502** and **503**, of the sensor **500** as well as the substrate and the dielectric layers are provided in a layered configuration or construction. For example, as shown in FIG. 5B, in one embodiment, the sensor **500** (such as the analyte sensor unit **101** of FIG. 1), includes a substrate layer **504**, and a first conducting layer **501** such as carbon, gold, etc., disposed on at least a portion of the substrate layer **504**, and which may provide the working electrode. Also shown disposed on at least a portion of the first conducting layer **501** is a sensing layer **508**.

A first insulation layer **505**, such as a first dielectric layer in certain embodiments, is disposed on at least a portion of the first conducting layer **501**, and further, a second conducting layer **509** may be disposed or stacked on top of at least a portion of the first insulation layer (or dielectric layer) **505**. As shown in FIG. 5B, the second conducting layer **509** may provide the reference electrode **502**, as described herein having an extended lifetime, which includes a layer of redox polymer as described herein.

A second insulation layer **506**, such as a second dielectric layer in certain embodiments, may be disposed or layered on at least a portion of the second conducting layer **509**. Further, a third conducting layer **503** may be disposed on at least a portion of the second insulation layer **506** and may provide the counter electrode **503**. Finally, a third insulation layer **507** may be disposed or layered on at least a portion of the third conducting layer **503**. In this manner, the sensor **500** may be layered such that at least a portion of each of the

conducting layers is separated by a respective insulation layer (for example, a dielectric layer). The embodiment of FIGS. 5A and 5B show the layers having different lengths. In certain instances, some or all of the layers may have the same or different lengths and/or widths.

In certain embodiments, some or all of the electrodes 501, 502, 503 may be provided on the same side of the substrate 504 in the layered construction as described above, or alternatively, may be provided in a co-planar manner such that two or more electrodes may be positioned on the same plane (e.g., side-by side (e.g., parallel) or angled relative to each other) on the substrate 504. For example, co-planar electrodes may include a suitable spacing therebetween and/or include a dielectric material or insulation material disposed between the conducting layers/electrodes. Furthermore, in certain embodiments, one or more of the electrodes 501, 502, 503 may be disposed on opposing sides of the substrate 504. In such embodiments, contact pads may be one the same or different sides of the substrate. For example, an electrode may be on a first side and its respective contact may be on a second side, e.g., a trace connecting the electrode and the contact may traverse through the substrate.

As noted above, analyte sensors may include an analyte-responsive enzyme to provide a sensing component or sensing layer. Some analytes, such as oxygen, can be directly electrooxidized or electroreduced on a sensor, and more specifically at least on a working electrode of a sensor. Other analytes, such as glucose and lactate, require the presence of at least one electron transfer agent and/or at least one catalyst to facilitate the electrooxidation or electroreduction of the analyte. Catalysts may also be used for those analytes, such as oxygen, that can be directly electrooxidized or electroreduced on the working electrode. For these analytes, each working electrode includes a sensing layer (see for example sensing layer 508 of FIG. 5B) proximate to or on a surface of a working electrode. In many embodiments, a sensing layer is formed near or on only a small portion of at least a working electrode.

The sensing layer includes one or more components constructed to facilitate the electrochemical oxidation or reduction of the analyte. The sensing layer may include, for example, a catalyst to catalyze a reaction of the analyte and produce a response at the working electrode, an electron transfer agent to transfer electrons between the analyte and the working electrode (or other component), or both.

A variety of different sensing layer configurations may be used. In certain embodiments, the sensing layer is deposited on the conductive material of a working electrode. The sensing layer may extend beyond the conductive material of the working electrode. In some cases, the sensing layer may also extend over other electrodes, e.g., over the counter electrode and/or reference electrode (or counter/reference is provided).

A sensing layer that is in direct contact with the working electrode may contain an electron transfer agent to transfer electrons directly or indirectly between the analyte and the working electrode, and/or a catalyst to facilitate a reaction of the analyte. For example, a glucose, lactate, or oxygen electrode may be formed having a sensing layer which contains a catalyst, including glucose oxidase, glucose dehydrogenase, lactate oxidase, or laccase, respectively, and an electron transfer agent that facilitates the electrooxidation of the glucose, lactate, or oxygen, respectively.

In other embodiments the sensing layer is not deposited directly on the working electrode. Instead, the sensing layer 508 may be spaced apart from the working electrode, and separated from the working electrode, e.g., by a separation

layer. A separation layer may include one or more membranes or films or a physical distance. In addition to separating the working electrode from the sensing layer, the separation layer may also act as a mass transport limiting layer and/or an interferent eliminating layer and/or a biocompatible layer.

In certain embodiments which include more than one working electrode, one or more of the working electrodes may not have a corresponding sensing layer, or may have a sensing layer which does not contain one or more components (e.g., an electron transfer agent and/or catalyst) needed to electrolyze the analyte. Thus, the signal at this working electrode may correspond to background signal which may be removed from the analyte signal obtained from one or more other working electrodes that are associated with fully-functional sensing layers by, for example, subtracting the signal.

In certain embodiments, the sensing layer includes one or more electron transfer agents. Electron transfer agents that may be employed are electroreducible and electrooxidizable ions or molecules having redox potentials that are a few hundred millivolts above or below the redox potential of the standard calomel electrode (SCE). The electron transfer agent may be organic, organometallic, or inorganic. Examples of organic redox species are quinones and species that in their oxidized state have quinoid structures, such as Nile blue and indophenol. Examples of organometallic redox species are metallocenes including ferrocene. Examples of inorganic redox species are hexacyanoferrate (III), ruthenium hexamine, etc. Additional examples include those described in U.S. Pat. Nos. 7,501,053 and 6,736,957 and U.S. Patent Publication No. 2006/0201805, the disclosures of which are incorporated herein by reference in their entirety.

In certain embodiments, electron transfer agents have structures or charges which prevent or substantially reduce the diffusional loss of the electron transfer agent during the period of time that the sample is being analyzed. For example, electron transfer agents include but are not limited to a redox species, e.g., bound to a polymer which can in turn be disposed on or near the working electrode. The bond between the redox species and the polymer may be covalent, coordinative, or ionic. Although any organic, organometallic or inorganic redox species may be bound to a polymer and used as an electron transfer agent, in certain embodiments the redox species is a transition metal compound or complex, e.g., osmium, ruthenium, iron, and cobalt compounds or complexes. It will be recognized that many redox species described for use with a polymeric component may also be used, without a polymeric component.

One type of polymeric electron transfer agent contains a redox species covalently bound in a polymeric composition. An example of this type of mediator is poly(vinylferrocene). Another type of electron transfer agent contains an ionically-bound redox species. This type of mediator may include a charged polymer coupled to an oppositely charged redox species. Examples of this type of mediator include a negatively charged polymer coupled to a positively charged redox species such as an osmium or ruthenium polypyridyl cation. Another example of an ionically-bound mediator is a positively charged polymer including quaternized poly(4-vinyl pyridine) or poly(1-vinyl imidazole) coupled to a negatively charged redox species such as ferricyanide or ferrocyanide. In other embodiments, electron transfer agents include a redox species coordinatively bound to a polymer. For example, the mediator may be formed by coordination

of an osmium or cobalt 2,2'-bipyridyl complex to poly(1-vinyl imidazole) or poly(4-vinyl pyridine).

Suitable electron transfer agents are osmium transition metal complexes with one or more ligands, each ligand having a nitrogen-containing heterocycle such as 2,2'-bipyridine, 1,10-phenanthroline, 1-methyl, 2-pyridyl biimidazole, or derivatives thereof. The electron transfer agents may also have one or more ligands covalently bound in a polymer, each ligand having at least one nitrogen-containing heterocycle, such as pyridine, imidazole, or derivatives thereof. One example of an electron transfer agent includes (a) a polymer or copolymer having pyridine or imidazole functional groups and (b) osmium cations complexed with two ligands, each ligand containing 2,2'-bipyridine, 1,10-phenanthroline, or derivatives thereof, the two ligands not necessarily being the same. Some derivatives of 2,2'-bipyridine for complexation with the osmium cation include but are not limited to 4,4'-dimethyl-2,2'-bipyridine and mono-, di-, and polyalkoxy-2,2'-bipyridines, including 4,4'-dimethoxy-2,2'-bipyridine. Derivatives of 1,10-phenanthroline for complexation with the osmium cation include but are not limited to 4,7-dimethyl-1,10-phenanthroline and mono, di-, and polyalkoxy-1,10-phenanthrolines, such as 4,7-dimethoxy-1,10-phenanthroline. Polymers for complexation with the osmium cation include but are not limited to polymers and copolymers of poly(1-vinyl imidazole) (referred to as "PVI") and poly(4-vinyl pyridine) (referred to as "PVP"). Suitable copolymer substituents of poly(1-vinyl imidazole) include acrylonitrile, acrylamide, and substituted or quaternized N-vinyl imidazole, e.g., electron transfer agents with osmium complexed to a polymer or copolymer of poly(1-vinyl imidazole).

Embodiments may employ electron transfer agents having a redox potential ranging from about -200 mV to about +200 mV versus the standard calomel electrode (SCE). The sensing layer may also include a catalyst which is capable of catalyzing a reaction of the analyte. The catalyst may also, in some embodiments, act as an electron transfer agent. One example of a suitable catalyst is an enzyme which catalyzes a reaction of the analyte. For example, a catalyst, including a glucose oxidase, glucose dehydrogenase (e.g., pyrroloquinoline quinone (PQQ), dependent glucose dehydrogenase, flavine adenine dinucleotide (FAD) dependent glucose dehydrogenase, or nicotinamide adenine dinucleotide (NAD) dependent glucose dehydrogenase), may be used when the analyte of interest is glucose. A lactate oxidase or lactate dehydrogenase may be used when the analyte of interest is lactate. Laccase may be used when the analyte of interest is oxygen or when oxygen is generated or consumed in response to a reaction of the analyte.

The sensing layer may also include a catalyst which is capable of catalyzing a reaction of the analyte. The catalyst may also, in some embodiments, act as an electron transfer agent. One example of a suitable catalyst is an enzyme which catalyzes a reaction of the analyte. For example, a catalyst, including a glucose oxidase, glucose dehydrogenase (e.g., pyrroloquinoline quinone (PQQ) dependent glucose dehydrogenase or oligosaccharide dehydrogenase, flavine adenine dinucleotide (FAD) dependent glucose dehydrogenase, nicotinamide adenine dinucleotide (NAD) dependent glucose dehydrogenase), may be used when the analyte of interest is glucose. A lactate oxidase or lactate dehydrogenase may be used when the analyte of interest is lactate. Laccase may be used when the analyte of interest is oxygen or when oxygen is generated or consumed in response to a reaction of the analyte.

In certain embodiments, a catalyst may be attached to a polymer, cross linking the catalyst with another electron transfer agent, which, as described above, may be polymeric. A second catalyst may also be used in certain embodiments. This second catalyst may be used to catalyze a reaction of a product compound resulting from the catalyzed reaction of the analyte. The second catalyst may operate with an electron transfer agent to electrolyze the product compound to generate a signal at the working electrode. Alternatively, a second catalyst may be provided in an interferent-eliminating layer to catalyze reactions that remove interferents.

In certain embodiments, the sensor includes a self-polymerizing hydrogel and works at a gentle oxidizing potential, e.g., a potential of about +40 mV vs. Ag/AgCl. This sensing layer uses, for example, an osmium (Os)-based mediator constructed for low potential operation and includes a self-polymerizing hydrogel. Accordingly, in certain embodiments the sensing element is a redox active component that includes (1) Osmium-based mediator molecules that include (bidentate) ligands, and (2) glucose oxidase enzyme molecules. These two constituents are combined together with a high self-polymerizing hydrogel.

A mass transport limiting layer (not shown), e.g., an analyte flux modulating layer, may be included with the sensor to act as a diffusion-limiting barrier to reduce the rate of mass transport of the analyte, for example, glucose or lactate, into the region around the working electrodes. The mass transport limiting layers are useful in limiting the flux of an analyte to a working electrode in an electrochemical sensor so that the sensor is linearly responsive over a large range of analyte concentrations and is easily calibrated. Mass transport limiting layers may include polymers and may be biocompatible. A mass transport limiting layer may provide many functions, e.g., biocompatibility and/or interferent-eliminating, etc.

In certain embodiments, a mass transport limiting layer is a membrane composed of crosslinked polymers containing heterocyclic nitrogen groups, such as polymers of polyvinylpyridine and polyvinylimidazole. Embodiments also include membranes that are made of a polyurethane, or polyether urethane, or chemically related material, or membranes that are made of silicone, and the like.

A membrane may be formed by crosslinking in situ a polymer, modified with a zwitterionic moiety, a non-pyridine copolymer component, and optionally another moiety that is either hydrophilic or hydrophobic, and/or has other desirable properties, in an alcohol-buffer solution. The modified polymer may be made from a precursor polymer containing heterocyclic nitrogen groups. For example, a precursor polymer may be polyvinylpyridine or polyvinylimidazole. Optionally, hydrophilic or hydrophobic modifiers may be used to "fine-tune" the permeability of the resulting membrane to an analyte of interest. Optional hydrophilic modifiers, such as poly(ethylene glycol), hydroxyl or polyhydroxyl modifiers, may be used to enhance the biocompatibility of the polymer or the resulting membrane.

A membrane may be formed in situ by applying an alcohol-buffer solution of a crosslinker and a modified polymer over an enzyme-containing sensing layer and allowing the solution to cure for about one to two days or other appropriate time period. The crosslinker-polymer solution may be applied to the sensing layer by placing a droplet or droplets of the solution on the sensor, by dipping the sensor into the solution, by spraying the solution on the sensor, and the like. Generally, the thickness of the mem-

brane is controlled by the concentration of the solution, by the number of droplets of the solution applied, by the number of times the sensor is dipped in the solution, by the volume of solution sprayed on the sensor, or by any combination of these factors. A membrane applied in this manner may have any combination of the following functions: (1) mass transport limitation, i.e., reduction of the flux of analyte that can reach the sensing layer, (2) biocompatibility enhancement, or (3) interferent reduction.

In certain embodiments, the sensing system detects hydrogen peroxide to infer glucose levels. For example, a hydrogen peroxide-detecting sensor may be constructed in which a sensing layer includes enzyme such as glucose oxidase, glucose dehydrogenase, or the like, and is positioned proximate to the working electrode. The sensing layer may be covered by one or more layers, e.g., a membrane that is selectively permeable to glucose. Once the glucose passes through the membrane, it is oxidized by the enzyme and reduced glucose oxidase can then be oxidized by reacting with molecular oxygen to produce hydrogen peroxide.

Certain embodiments include a hydrogen peroxide-detecting sensor constructed from a sensing layer prepared by combining together, for example: (1) a redox mediator having a transition metal complex including an Os polypyridyl complex with oxidation potentials of about +200 mV vs. SCE, (2) a self-polymerizing hydrogel, and (3) periodate oxidized horseradish peroxidase (HRP). Such a sensor functions in a reductive mode; the working electrode is controlled at a potential negative to that of the Os complex, resulting in mediated reduction of hydrogen peroxide through the HRP catalyst.

In another example, a potentiometric sensor can be constructed as follows. A glucose-sensing layer is constructed by combining together (1) a redox mediator having a transition metal complex including an Os polypyridyl complex with oxidation potentials from about -200 mV to +200 mV vs. SCE, and (2) a self-polymerizing hydrogel, and (3) glucose oxidase. This sensor can then be used in a potentiometric mode, by exposing the sensor to a glucose containing solution, under conditions of zero current flow, and allowing the ratio of reduced/oxidized Os to reach an equilibrium value. The reduced/oxidized Os ratio varies in a reproducible way with the glucose concentration, and will cause the electrode's potential to vary in a similar way.

The substrate may be formed using a variety of non-conducting materials, including, for example, polymeric or plastic materials and ceramic materials. Suitable materials for a particular sensor may be determined, at least in part, based on the desired use of the sensor and properties of the materials.

In some embodiments, the substrate is flexible. For example, if the sensor is configured for implantation into a user, then the sensor may be made flexible (although rigid sensors may also be used for implantable sensors) to reduce pain to the user and damage to the tissue caused by the implantation of and/or the wearing of the sensor. A flexible substrate often increases the user's comfort and allows a wider range of activities. Suitable materials for a flexible substrate include, for example, non-conducting plastic or polymeric materials and other non-conducting, flexible, deformable materials. Examples of useful plastic or polymeric materials include thermoplastics such as polycarbonates, polyesters (e.g., Mylar™ and polyethylene terephthalate (PET)), polyvinyl chloride (PVC), polyurethanes, polyethers, polyamides, polyimides, or copolymers of these thermoplastics, such as PETG (glycol-modified polyethylene terephthalate).

In other embodiments, the sensors are made using a relatively rigid substrate to, for example, provide structural support against bending or breaking. Examples of rigid materials that may be used as the substrate include poorly conducting ceramics, such as aluminum oxide and silicon dioxide. An implantable sensor having a rigid substrate may have a sharp point and/or a sharp edge to aid in implantation of a sensor without an additional insertion device.

It will be appreciated that for many sensors and sensor applications, both rigid and flexible sensors will operate adequately. The flexibility of the sensor may also be controlled and varied along a continuum by changing, for example, the composition and/or thickness of the substrate.

In addition to considerations regarding flexibility, it is often desirable that implantable sensors should have a substrate which is physiologically harmless, for example, a substrate approved by a regulatory agency or private institution for in vivo use.

The sensor may include optional features to facilitate insertion of an implantable sensor. For example, the sensor may be pointed at the tip to ease insertion. In addition, the sensor may include a barb which assists in anchoring the sensor within the tissue of the user during operation of the sensor. However, the barb is typically small enough so that little damage is caused to the subcutaneous tissue when the sensor is removed for replacement.

An implantable sensor may also, optionally, have an anticlotting agent disposed on a portion of the substrate which is implanted into a user. This anticlotting agent may reduce or eliminate the clotting of blood or other body fluid around the sensor, particularly after insertion of the sensor. Blood clots may foul the sensor or irreproducibly reduce the amount of analyte which diffuses into the sensor. Examples of useful anticlotting agents include heparin and tissue plasminogen activator (TPA), as well as other known anticlotting agents.

The anticlotting agent may be applied to at least a portion of that part of the sensor that is to be implanted. The anticlotting agent may be applied, for example, by bath, spraying, brushing, or dipping, etc. The anticlotting agent is allowed to dry on the sensor. The anticlotting agent may be immobilized on the surface of the sensor or it may be allowed to diffuse away from the sensor surface. Typically, the quantities of anticlotting agent disposed on the sensor are far below the amounts typically used for treatment of medical conditions involving blood clots and, therefore, have only a limited, localized effect.

#### Insertion Device

An insertion device can be used to subcutaneously insert the sensor into the user. The insertion device is typically formed using structurally rigid materials, such as metal or rigid plastic. Materials may include stainless steel and ABS (acrylonitrile-butadiene-styrene) plastic. In some embodiments, the insertion device is pointed and/or sharp at the tip to facilitate penetration of the skin of the user. A sharp, thin insertion device may reduce pain felt by the user upon insertion of the sensor. In other embodiments, the tip of the insertion device has other shapes, including a blunt or flat shape. These embodiments may be useful when the insertion device does not penetrate the skin but rather serves as a structural support for the sensor as the sensor is pushed into the skin.

#### Sensor Control Unit

The sensor control unit can be integrated in the sensor, part or all of which is subcutaneously implanted or it can be configured to be placed on the skin of a user. The sensor control unit is optionally formed in a shape that is comfort-

able to the user and which may permit concealment, for example, under a user's clothing. The thigh, leg, upper arm, shoulder, or abdomen are convenient parts of the user's body for placement of the sensor control unit to maintain concealment. However, the sensor control unit may be positioned on other portions of the user's body. One embodiment of the sensor control unit has a thin, oval shape to enhance concealment. However, other shapes and sizes may be used.

The particular profile, as well as the height, width, length, weight, and volume of the sensor control unit may vary and depends, at least in part, on the components and associated functions included in the sensor control unit. In general, the sensor control unit includes a housing typically formed as a single integral unit that rests on the skin of the user. The housing typically contains most or all of the electronic components of the sensor control unit.

The housing of the sensor control unit may be formed using a variety of materials, including, for example, plastic and polymeric materials, such as rigid thermoplastics and engineering thermoplastics. Suitable materials include, for example, polyvinyl chloride, polyethylene, polypropylene, polystyrene, ABS polymers, and copolymers thereof. The housing of the sensor control unit may be formed using a variety of techniques including, for example, injection molding, compression molding, casting, and other molding methods. Hollow or recessed regions may be formed in the housing of the sensor control unit. The electronic components of the sensor control unit and/or other items, including a battery or a speaker for an audible alarm, may be placed in the hollow or recessed areas.

The sensor control unit is typically attached to the skin of the user, for example, by adhering the sensor control unit directly to the skin of the user with an adhesive provided on at least a portion of the housing of the sensor control unit which contacts the skin or by suturing the sensor control unit to the skin through suture openings in the sensor control unit.

When positioned on the skin of a user, the sensor and the electronic components within the sensor control unit are coupled via conductive contacts. The one or more working electrodes, counter electrode (or counter/reference electrode), optional reference electrode, and optional temperature probe are attached to individual conductive contacts. For example, the conductive contacts are provided on the interior of the sensor control unit. Other embodiments of the sensor control unit have the conductive contacts disposed on the exterior of the housing. The placement of the conductive contacts is such that they are in contact with the contact pads on the sensor when the sensor is properly positioned within the sensor control unit.

#### Sensor Control Unit Electronics

The sensor control unit also typically includes at least a portion of the electronic components that operate the sensor and the analyte monitoring device system. The electronic components of the sensor control unit typically include a power supply for operating the sensor control unit and the sensor, a sensor circuit for obtaining signals from and operating the sensor, a measurement circuit that converts sensor signals to a desired format, and a processing circuit that, at minimum, obtains signals from the sensor circuit and/or measurement circuit and provides the signals to an optional transmitter. In some embodiments, the processing circuit may also partially or completely evaluate the signals from the sensor and convey the resulting data to the optional transmitter and/or activate an optional alarm system if the analyte level exceeds a threshold. The processing circuit often includes digital logic circuitry.

The sensor control unit may optionally contain a transmitter for transmitting the sensor signals or processed data from the processing circuit to a receiver/display unit; a data storage unit for temporarily or permanently storing data from the processing circuit; a temperature probe circuit for receiving signals from and operating a temperature probe; a reference voltage generator for providing a reference voltage for comparison with sensor-generated signals; and/or a watchdog circuit that monitors the operation of the electronic components in the sensor control unit.

Moreover, the sensor control unit may also include digital and/or analog components utilizing semiconductor devices, including transistors. To operate these semiconductor devices, the sensor control unit may include other components including, for example, a bias control generator to correctly bias analog and digital semiconductor devices, an oscillator to provide a clock signal, and a digital logic and timing component to provide timing signals and logic operations for the digital components of the circuit.

As an example of the operation of these components, the sensor circuit and the optional temperature probe circuit provide raw signals from the sensor to the measurement circuit. The measurement circuit converts the raw signals to a desired format, using for example, a current-to-voltage converter, current-to-frequency converter, and/or a binary counter or other indicator that produces a signal proportional to the absolute value of the raw signal. This may be used, for example, to convert the raw signal to a format that can be used by digital logic circuits. The processing circuit may then, optionally, evaluate the data and provide commands to operate the electronics.

#### Calibration

Sensors may be configured to require no system calibration or no user calibration. For example, a sensor may be factory calibrated and need not require further calibrating. In certain embodiments, calibration may be required, but may be done without user intervention, i.e., may be automatic. In those embodiments in which calibration by the user is required, the calibration may be according to a predetermined schedule or may be dynamic, i.e., the time for which may be determined by the system on a real-time basis according to various factors, including, but not limited to, glucose concentration and/or temperature and/or rate of change of glucose, etc.

In addition to a transmitter, an optional receiver may be included in the sensor control unit. In some cases, the transmitter is a transceiver, operating as both a transmitter and a receiver. The receiver may be used to receive calibration data for the sensor. The calibration data may be used by the processing circuit to correct signals from the sensor. This calibration data may be transmitted by the receiver/display unit or from some other source such as a control unit in a doctor's office. In addition, the optional receiver may be used to receive a signal from the receiver/display units to direct the transmitter, for example, to change frequencies or frequency bands, to activate or deactivate the optional alarm system and/or to direct the transmitter to transmit at a higher rate.

Calibration data may be obtained in a variety of ways. For instance, the calibration data may simply be factory-determined calibration measurements which can be input into the sensor control unit using the receiver or may alternatively be stored in a calibration data storage unit within the sensor control unit itself (in which case a receiver may not be needed). The calibration data storage unit may be, for example, a readable or readable/writeable memory circuit.

Calibration may be accomplished using an in vitro test strip (or other reference), e.g., a small sample test strip such as a test strip that requires less than about 1 microliter of sample (for example FreeStyle® blood glucose monitoring test strips from Abbott Diabetes Care, Alameda, Calif.). For example, test strips that require less than about 1 nanoliter of sample may be used. In certain embodiments, a sensor may be calibrated using only one sample of body fluid per calibration event. For example, a user need only lance a body part one time to obtain a sample for a calibration event (e.g., for a test strip), or may lance more than one time within a short period of time if an insufficient volume of sample is firstly obtained. Embodiments include obtaining and using multiple samples of body fluid for a given calibration event, where glucose values of each sample are substantially similar. Data obtained from a given calibration event may be used independently to calibrate or combined with data obtained from previous calibration events, e.g., averaged including weighted averaged, etc., to calibrate. In certain embodiments, a system need only be calibrated once by a user, where recalibration of the system is not required.

Alternative or additional calibration data may be provided based on tests performed by a doctor or some other professional or by the user. For example, it is common for diabetic individuals to determine their own blood glucose concentration using commercially available testing kits. The results of this test is input into the sensor control unit either directly, if an appropriate input device (e.g., a keypad, an optical signal receiver, or a port for connection to a keypad or computer) is incorporated in the sensor control unit, or indirectly by inputting the calibration data into the receiver/display unit and transmitting the calibration data to the sensor control unit.

Other methods of independently determining analyte levels may also be used to obtain calibration data. This type of calibration data may supplant or supplement factory-determined calibration values.

In some embodiments of the invention, calibration data may be required at periodic intervals, for example, every eight hours, once a day, or once a week, to confirm that accurate analyte levels are being reported. Calibration may also be required each time a new sensor is implanted or if the sensor exceeds a threshold minimum or maximum value or if the rate of change in the sensor signal exceeds a threshold value. In some cases, it may be necessary to wait a period of time after the implantation of the sensor before calibrating to allow the sensor to achieve equilibrium. In some embodiments, the sensor is calibrated only after it has been inserted. In other embodiments, no calibration of the sensor is needed.

#### Analyte Monitoring Device

In some embodiments of the invention, the analyte monitoring device includes a sensor control unit and a sensor. In these embodiments, the processing circuit of the sensor control unit is able to determine a level of the analyte and activate an alarm system if the analyte level exceeds a threshold. The sensor control unit, in these embodiments, has an alarm system and may also include a display, such as an LCD or LED display.

A threshold value is exceeded if the datapoint has a value that is beyond the threshold value in a direction indicating a particular condition. For example, a datapoint which correlates to a glucose level of 200 mg/dL exceeds a threshold value for hyperglycemia of 180 mg/dL, because the datapoint indicates that the user has entered a hyperglycemic state. As another example, a datapoint which correlates to a glucose level of 65 mg/dL exceeds a threshold value for hypoglycemia of 70 mg/dL because the datapoint indicates

that the user is hypoglycemic as defined by the threshold value. However, a datapoint which correlates to a glucose level of 75 mg/dL would not exceed the same threshold value for hypoglycemia because the datapoint does not indicate that particular condition as defined by the chosen threshold value.

An alarm may also be activated if the sensor readings indicate a value that is beyond a measurement range of the sensor. For glucose, the physiologically relevant measurement range is typically 30-400 mg/dL, including 40-300 mg/dL and 50-250 mg/dL, of glucose in the interstitial fluid.

The alarm system may also, or alternatively, be activated when the rate of change or acceleration of the rate of change in analyte level increase or decrease reaches or exceeds a threshold rate or acceleration. For example, in the case of a subcutaneous glucose monitor, the alarm system might be activated if the rate of change in glucose concentration exceeds a threshold value which might indicate that a hyperglycemic or hypoglycemic condition is likely to occur.

A system may also include system alarms that notify a user of system information such as battery condition, calibration, sensor dislodgment, sensor malfunction, etc. Alarms may be, for example, auditory and/or visual. Other sensory-stimulating alarm systems may be used including alarm systems which heat, cool, vibrate, or produce a mild electrical shock when activated.

#### Drug Delivery System

The subject invention also includes sensors used in sensor-based drug delivery systems. The system may provide a drug to counteract the high or low level of the analyte in response to the signals from one or more sensors. Alternatively, the system may monitor the drug concentration to ensure that the drug remains within a desired therapeutic range. The drug delivery system may include one or more (e.g., two or more) sensors, a processing unit such as a transmitter, a receiver/display unit, and a drug administration system. In some cases, some or all components may be integrated in a single unit. A sensor-based drug delivery system may use data from the one or more sensors to provide necessary input for a control algorithm/mechanism to adjust the administration of drugs, e.g., automatically or semi-automatically. As an example, a glucose sensor may be used to control and adjust the administration of insulin from an external or implanted insulin pump.

Each of the various references, presentations, publications, provisional and/or non-provisional U.S. patent applications, U.S. patents, non-U.S. patent applications, and/or non-U.S. patents that have been identified herein, is incorporated herein by reference in its entirety.

Other embodiments and modifications within the scope of the present disclosure will be apparent to those skilled in the relevant art. Various modifications, processes, as well as numerous structures to which the embodiments of the invention may be applicable will be readily apparent to those of skill in the art to which the invention is directed upon review of the specification. Various aspects and features of the invention may have been explained or described in relation to understandings, beliefs, theories, underlying assumptions, and/or working or prophetic examples, although it will be understood that the invention is not bound to any particular understanding, belief, theory, underlying assumption, and/or working or prophetic example. Although various aspects and features of the invention may have been described largely with respect to applications, or more specifically, medical applications, involving diabetic humans, it will be understood that such aspects and features also relate to any of a variety of applications involving non-diabetic humans and

any and all other animals. Further, although various aspects and features of the invention may have been described largely with respect to applications involving partially implanted sensors, such as transcutaneous or subcutaneous sensors, it will be understood that such aspects and features also relate to any of a variety of sensors that are suitable for use in connection with the body of an animal or a human, such as those suitable for use as fully implanted in the body of an animal or a human. Finally, although the various aspects and features of the invention have been described with respect to various embodiments and specific examples herein, all of which may be made or carried out conventionally, it will be understood that the invention is entitled to protection within the full scope of the appended claims.

The following examples are put forth so as to provide those of ordinary skill in the art with a complete disclosure and description of how to make and use the embodiments of the invention, and are not intended to limit the scope of what the inventors regard as their invention nor are they intended to represent that the experiments below are all or the only experiments performed. Efforts have been made to ensure accuracy with respect to numbers used (e.g., amounts, temperature, etc.) but some experimental errors and deviations should be accounted for. Unless indicated otherwise, parts are parts by weight, molecular weight is weight average molecular weight, temperature is in degrees Centigrade, and pressure is at or near atmospheric.

## EXAMPLES

### Sensors Having PEG Epoxide Crosslinked Hydrogel Membranes

#### Carbon Backed Sensors

Adhesion studies were performed on carbon backed analyte sensors coated with two membranes. The first membrane was a heterocyclic nitrogen-containing polymer membrane, and the second membrane included a hydrogel with a PEG epoxide crosslinker. First, carbon backed sensors were dipped in a first membrane formulation that included a heterocyclic nitrogen-containing polymer (e.g., a 10Q5-based membrane). Sixty carbon backed sensors were dipped 3 times each in the 10Q5-based membrane formulation. Exit dip speed was 46 mm/sec. The sensors were allowed to cure overnight in a laboratory fume hood and then held for 7 days in a chamber at 25° C. After curing and drying, the membrane coated sensors were coated with a second membrane. The membrane coated sensors were divided into two groups of 30 sensors each. Each sensor in the first group of 30 sensors was dipped twice in a 10Q5-based membrane formulation that included a 4-arm PEG epoxide (10 kDa) crosslinker. Each sensor in the second group of 30 sensors was dipped twice in a 10Q5-based membrane formulation that included a 4-arm PEG epoxide (10 kDa) crosslinker and 5% TEC. Exit dip speed was 90 mm/sec for both groups. The membrane coated sensors were soaked in phosphate buffered saline (PBS) and microphotographs of the sensors were taken at 1 hour and 24 hours.

FIGS. 6A and 6B show microphotographs taken at 1 hour and 24 hours, respectively, of a carbon backed sensor with membrane that included a 10Q5-based hydrogel with a 4-arm PEG epoxide (10 kDa) crosslinker. FIGS. 6A and 6B illustrate that over time the membrane coatings on the sensor swelled due to the absorption of water.

FIGS. 7A and 7B show microphotographs taken at 1 hour and 24 hours, respectively, of a carbon backed sensor with a membrane that included a 10Q5-based hydrogel with a

4-arm PEG epoxide (10 kDa) crosslinker and 5% TEC. FIGS. 7A and 7B illustrate that over time the membrane coatings on the sensor swelled due to the absorption of water. In addition, comparison of FIGS. 6A-6B with FIGS. 7A-7B demonstrate that the inclusion of 5% TEC in the second membrane formulation did not significantly affect water absorption over time.

#### Non-Carbon Backed Sensors

Adhesion studies were performed on non-carbon backed analyte sensors coated with two membranes. The first membrane was a heterocyclic nitrogen-containing polymer membrane, and the second membrane included a hydrogel with a PEG epoxide crosslinker. First, non-carbon backed sensors were dipped in a first membrane formulation that included a heterocyclic nitrogen-containing polymer (e.g., a 10Q5-based membrane) and 5% TEC. Sixty non-carbon backed sensors were dipped 3 times each in the 10Q5-based membrane formulation with 5% TEC. Exit dip speed was 46 mm/sec. The sensors were allowed to cure overnight in a laboratory fume hood and then held for 7 days in a chamber at 25° C. After curing and drying, the membrane coated sensors were coated with a second membrane. The membrane coated sensors were divided into two groups of 30 sensors each. Each sensor in the first group of 30 sensors was dipped twice in a 10Q5-based membrane formulation that included a 4-arm PEG epoxide (10 kDa) crosslinker. Each sensor in the second group of 30 sensors was dipped twice in a 10Q5-based membrane formulation that included a 4-arm PEG epoxide (10 kDa) crosslinker and 5% TEC. Exit dip speed was 90 mm/sec for both groups. The membrane coated sensors were soaked in phosphate buffered saline (PBS) and microphotographs of the sensors were taken at 1 hour and 24 hours.

FIGS. 8A and 8B show microphotographs taken at 1 hour and 24 hours, respectively, of a non-carbon backed sensor with membrane that included a 10Q5-based hydrogel with a 4-arm PEG epoxide (10 kDa) crosslinker. FIGS. 8A and 8B illustrate that over time the membrane coatings on the sensor swelled due to the absorption of water.

FIGS. 9A and 9B show microphotographs taken at 1 hour and 24 hours, respectively, of a non-carbon backed sensor with membrane that included a 10Q5-based hydrogel with a 4-arm PEG epoxide (10 kDa) crosslinker and 5% TEC. FIGS. 9A and 9B illustrate that over time the membrane coatings on the sensor swelled due to the absorption of water. In addition, comparison of FIGS. 8A-8B with FIGS. 9A-9B demonstrate that inclusion of 5% TEC in the membrane formulation did not significantly affect water absorption over time. Furthermore, comparison of FIGS. 6A-6B and FIGS. 7A-7B with FIGS. 8A-8B and FIGS. 9A-9B demonstrate that water absorption by the membranes appeared similar for carbon and non-carbon backed sensors.

FIG. 10 shows one-way analysis of variance (ANOVA) graphs of sensitivity/slope (nA/mM) for carbon and non-carbon backed sensors with various PEG epoxide crosslinked membranes, e.g., carbon backed sensors with a 10Q5-based hydrogel membrane with a 4-arm PEG epoxide (10 kDa) crosslinker, carbon backed sensors with a 10Q5-based hydrogel membrane with a 4-arm PEG epoxide (10 kDa) crosslinker and 5% TEC, non-carbon backed sensors with a 10Q5-based hydrogel membrane with a 4-arm PEG epoxide (10 kDa) crosslinker, and non-carbon backed sensors with a 10Q5-based hydrogel membrane with a 4-arm PEG epoxide (10 kDa) crosslinker and 5% TEC. As demonstrated in FIG. 10, the carbon and non-carbon backed sensors with and



TABLE 3

Means for One-Way ANOVA					
Level	Number	Mean	Std Error	Lower 95%	Upper 95%
1A Control	14	0.514286	0.01515	0.48373	0.54484
4arm + 1 mg Gly3	16	0.520000	0.01417	0.49142	0.54858
4arm + 3 mg Gly3	16	0.525250	0.01417	0.49667	0.55383

Standard error used a pooled estimate of error variance.

FIG. 17 shows graphs of one-way ANOVA of average response time (sec) for analyte sensors with various 4-arm PEG epoxide crosslinked membranes, e.g., sensors with a hydrogel membrane that included a 4-arm PEG epoxide (10 kDa) crosslinker and 1 mg Gly3, and sensors with a hydrogel membrane that included a 4-arm PEG epoxide (10 kDa) crosslinker and 3 mg Gly3. As demonstrated in FIG. 17, the sensors with 1 mg Gly3 and 3 mg Gly3 had similar average response times to a control sensor with no Gly3. One-way ANOVA data is shown in Table 4 below.

TABLE 4

Means for One-Way ANOVA					
Level	Number	Mean	Std Error	Lower 95%	Upper 95%
1A Control	14	171.154	18.462	133.92	208.38
4arm + 1 mg Gly3	16	265.563	17.269	230.74	300.39
4arm + 3 mg Gly3	16	281.375	17.269	246.55	316.20

Standard error used a pooled estimate of error variance.

Sensors Having PEG Acrylate Crosslinked Hydrogel Membranes

PEG Diacrylate Hydrogel Membranes

Studies were performed on membranes formed by in situ self-polymerization of PEG diacrylate hydrogels. PEG diacrylate solutions in PBS were prepared at a concentration of 10% PEG diacrylate. Solutions of PEG diacrylate and an activating agent were prepared by combining 3 ml of a 10% PEG diacrylate solution (5 kDa) in PBS with 200 mg of ferrous gluconate. Solutions of PEG diacrylate and initiator were prepared by combining 3 ml of a 10% PEG diacrylate (5 kDa) solution in PBS with 100 mg of hydrogen peroxide. Analyte sensors were dipped in each solution sequentially and allowed to self-polymerize in situ. The membrane coated sensors were soaked in phosphate buffered saline (PBS) and microphotographs of the sensors were taken at 30 minutes.

FIG. 18 shows a microphotograph taken after 30 min soaking in PBS of an analyte sensor with a membrane that included a PEG diacrylate (5 kDa) hydrogel. FIG. 18 illustrates that over time the membrane coating on the sensor swelled due to the absorption of water.

FIG. 19 shows graphs of one-way ANOVA of sensitivity/slope (nA/mM) for analyte sensors with various PEG diacrylate membranes, e.g., sensors with membranes that included: PEG diacrylate (400 Da) and an exit dip speed of 40 mm/sec; PEG diacrylate (400 Da) and an exit dip speed of 60 mm/sec; PEG diacrylate (5 kDa) and an exit dip speed of 30 mm/sec; and PEG diacrylate (5 kDa) and an exit dip speed of 40 mm/sec. As demonstrated in FIG. 19, the sensors had similar sensitivities to control sensors. One-way ANOVA data is shown in Table 5 below.

TABLE 5

Summary of Fit		
Rsquare		0.170063
Adj Rsquare		0.093218
Root Mean Square Error		0.067327
Mean of Response		0.541467
Observations (or Sum Wgts)		60

Analysis of Variance					
Source	DF	Sum of Squares	Mean Square	F Ratio	Prob > F
PEG Diacry m.w. 400 & m.w. 5k	5	0.06015732	0.010031	2.2130	0.0662
Error	54	0.24477561	0.004533		
C. Total	58	0.29493293			

Means for One-Way ANOVA					
Level	Number	Mean	Std Error	Lower 95%	Upper 95%
PEG Acry 400 ex. dip 40 mm/sec	6	0.526667	0.02749	0.47156	0.58177
PEG Acry 400 ex. dip 60 mm/sec	8	0.577375	0.02380	0.52965	0.62510
PEG Acry 5k ex. dip 30 mm/sec	8	0.544125	0.02380	0.49840	0.59185
PEG Acry 5k ex. dip 40 mm/sec	8	0.653526	0.02380	0.50590	0.60136
control A	16	0.499427	0.01683	0.46568	0.53318
control B	14	0.588857	0.01799	0.53078	0.60293

Standard error used a pooled estimate of error variance.

FIG. 20 shows graphs of one-way ANOVA of average response time (sec) for analyte sensors with various PEG diacrylate membranes, e.g., sensors with membranes that included: PEG diacrylate (400 Da) and an exit dip speed of 40 mm/sec; PEG diacrylate (400 Da) and an exit dip speed of 60 mm/sec; PEG diacrylate (5 kDa) and an exit dip speed of 30 mm/sec; and PEG diacrylate (5 kDa) and an exit dip speed of 40 mm/sec. As demonstrated in FIG. 20, the sensors had similar average response times to control sensors. One-way ANOVA data is shown in Table 6 below.

TABLE 6

Summary of Fit		
Rsquare		0.237398
Adj Rsquare		0.166784
Root Mean Square Error		38.92626
Mean of Response		235.2358
Observations (or Sum Wgts)		60

Analysis of Variance					
Source	DF	Sum of Squares	Mean Square	F Ratio	Prob > F
PEG Diacry m.w. 400 & m.w. 5k	5	25474.01	5094.80	3.3620	0.0102
Error	54	81832.13	1515.41		
C. Total	58	107306.14			

TABLE 6-continued

Means for One-Way ANOVA					
Level	Number	Mean	Std Error	Lower 95%	Upper 95%
PEG Acry 400 ex. dip 40 mm/sec	6	222.750	15.892	130.89	254.60
PEG Acry 400 ex. dip 60 mm/sec	8	208.938	13.763	182.34	237.53
PEG Acry 5k ex. dip 30 mm/sec	8	275.306	13.763	248.71	303.90
PEG Acry 5k ex. dip 40 mm/sec	8	239.205	13.763	211.61	265.80
control A	16	245.213	9.732	225.70	264.72
control B	14	217.904	10.404	197.04	238.76

Standard error used a pooled estimate of error variance.

4-Arm PEG Acrylate Crosslinked Hydrogel Membranes

Studies were performed on membranes formed by in situ self-polymerization of a hydrogel membrane that included a 4-arm PEG acrylate (10 kDa) crosslinker. Sensors were prepared with 1, 2 or 3 coatings of the hydrogel membrane that included a 4-arm PEG acrylate crosslinker.

FIG. 21 shows graphs of one-way ANOVA of sensitivity/slope (nA/mM) for analyte sensors with hydrogel membranes that included a 4-arm PEG acrylate crosslinker, e.g., sensors with 1, 2 or 3 coatings of the hydrogel membrane that included a 4-arm PEG acrylate (10 kDa) crosslinker. As demonstrated in FIG. 21, the sensors with 1, 2 or 3 coatings of the hydrogel membrane that included a 4-arm PEG acrylate (10 kDa) crosslinker had similar sensitivities to a control sensor. One-way ANOVA data is shown in Table 7 below.

TABLE 7

Summary of Fit					
Rsquare				0.06624	
Adj Rsquare				-0.03381	
Root Mean Square Error				0.062297	
Mean of Response				0.508437	
Observations (or Sum Wgts)				32	

Analysis of Variance					
Source	DF	Sum of Squares	Mean Square	F Ratio	Prob > F
4arm 10k 1dip, 2dip, 3dip and control Error	3	0.00770863	0.002570	0.6621	0.5823
	28	0.10866525	0.003881		
C. Total	31	0.11637388			

Means for One-Way ANOVA					
Level	Number	Mean	Std Error	Lower 95%	Upper 95%
1dip	8	0.516000	0.02203	0.47088	0.56112
2dip	8	0.529375	0.02203	0.48426	0.57449
3dip	8	0.488625	0.02203	0.44351	0.53374
Control	8	0.499750	0.02203	0.45463	0.54487

Standard error used a pooled estimate of error variance.

FIG. 22 shows graphs of one-way ANOVA of average response time (sec) for analyte sensors with hydrogel membranes that included a 4-arm PEG acrylate crosslinker, e.g., sensors with 1, 2 or 3 coatings of a hydrogel membrane that included a 4-arm PEG acrylate (10 kDa) crosslinker. As demonstrated in FIG. 22, the sensors with 1, 2 or 3 coatings of the hydrogel membrane that included a 4-arm PEG

acrylate (10 kDa) crosslinker had similar average response times to a control sensor. One-way ANOVA data is shown in Table 8 below.

TABLE 8

Summary of Fit					
Rsquare					0.357155
Adj Rsquare					0.288178
Root Mean Square Error					39.52229
Mean of Response					226.4547
Observations (or Sum Wgts)					32

Analysis of Variance					
Source	DF	Sum of Squares	Mean Square	F Ratio	Prob > F
4arm 10k 1dip, 2dip, 3dip and control Error	3	24299.191	8099.73	5.1855	0.0056
	28	43736.310	1562.01		
C. Total	31	68035.502			

Means for One-Way ANOVA					
Level	Number	Mean	Std Error	Lower 95%	Upper 95%
1dip	8	207.594	13.973	178.97	236.22
2dip	8	225.431	13.973	196.81	254.05
3dip	8	271.631	13.973	243.01	300.25
Control	8	201.162	13.973	172.54	229.79

Standard error used a pooled estimate of error variance.

Sensors Having PEG Acrylate Crosslinked Hydrogel Membranes with Swelling Modulators

Studies were performed on membranes formed by in situ self-polymerization of a PEG triacrylate hydrogel with a 4-arm PEG acrylate crosslinker and a swelling modulator. Solutions of PEG triacrylate were prepared in PBS with a 4-arm PEG acrylate (10 kDa) crosslinker at a concentration of either 100 mg/ml or 200 mg/ml. Solutions of PEG triacrylate with a 4-arm PEG acrylate (10 kDa) crosslinker and an activating agent were prepared by combining 3 ml of PEG triacrylate solution in PBS with either 100 mg/ml or 200 mg/ml of a 4-arm PEG acrylate (10 kDa) crosslinker and 200 mg of ferrous gluconate. Solutions of PEG triacrylate with a 4-arm PEG acrylate (10 kDa) crosslinker and an initiator were prepared by combining 3 ml of PEG triacrylate solution in PBS with either 100 mg/ml or 200 mg/ml of a 4-arm PEG acrylate (10 kDa) crosslinker and 100 mg of hydrogen peroxide. 100 mg of a swelling modulator, trimethylol propane triacrylate (TMPTA), was added to the membrane formulations. Analyte sensors were dipped in each solution sequentially and allowed to self-polymerize in situ. Sensors were prepared with either 1 or 2 coatings of the membrane formulation. The membrane coated sensors were soaked in phosphate buffered saline (PBS) and microphotographs of the sensors were taken at various time intervals.

FIGS. 23A and 23B show microphotographs of an analyte sensor with a membrane that included 1 coating of a PEG triacrylate membrane formulation with 100 mg/ml 4-arm PEG acrylate (10 kDa) crosslinker and TMPTA taken after the membrane coated sensor was soaked in PBS for 1 hour and 5 days, respectively. FIGS. 23A and 23B demonstrate that inclusion of TMPTA in the membrane formulations controlled the amount of water uptake by the membranes.

FIGS. 24A and 24B show microphotographs of an analyte sensor with a membrane that included 2 coatings of a PEG triacrylate membrane formulation with 100 mg/ml 4-arm PEG acrylate (10 kDa) crosslinker and TMPTA taken after

the membrane coated sensor was soaked in PBS for 1 hour and 5 days, respectively. FIGS. 24A and 24B demonstrate that inclusion of TMPTA in the membrane formulations controlled the amount of water uptake by the membranes.

FIGS. 25A and 25B show microphotographs of an analyte sensor with a membrane that included 1 coating of a PEG triacrylate membrane formulation with 200 mg/ml 4-arm PEG acrylate (10 kDa) crosslinker and TMPTA taken after the membrane coated sensor was soaked in PBS for 1 hour and 5 days, respectively. FIGS. 25A and 25B demonstrate that inclusion of TMPTA in the membrane formulations controlled the amount of water uptake by the membranes.

FIGS. 26A and 26B show microphotographs of an analyte sensor with a membrane that included 2 coatings of a PEG triacrylate membrane formulation with 200 mg/ml 4-arm PEG acrylate (10 kDa) crosslinker and TMPTA taken after the membrane coated sensor was soaked in PBS for 1 hour and 5 days, respectively. FIGS. 26A and 26B demonstrate that inclusion of TMPTA in the membrane formulations controlled the amount of water uptake by the membranes.

In conclusion, the experiments above show that the addition of hydrogel membranes to an analyte sensor formulation, such as a membrane that includes a hydrogel, a crosslinker, and a swelling modulator, promotes improved signal response and stability of the analyte sensor and substantial elimination of the "early signal attenuation" effect and night time drop-outs.

That which is claimed is:

1. A method for monitoring a level of an analyte, the method comprising:

inserting an electrochemical sensor into skin of a patient, wherein the electrochemical sensor comprises:

a working electrode comprising a sensing layer disposed thereon;

a membrane disposed over the sensing layer, wherein the membrane comprises a hydrogel, a crosslinker, and a swelling modulator comprising a 3-arm epoxide;

collecting data regarding a level of an analyte from signals generated by the sensor;

transmitting the collected data to a display unit; and displaying an indication of the level of the analyte on a display of the display unit.

2. The method of claim 1, wherein the membrane reduces the absorption of water as compared to a membrane in the absence of the swelling modulator.

3. The method of claim 1, wherein the hydrogel comprises a heterocyclic nitrogen-containing polymer hydrogel.

4. The method of claim 3, wherein the crosslinker comprises a 4-arm polyethylene glycol epoxide.

5. The method of claim 4, wherein the 4-arm polyethylene glycol epoxide has a molecular weight of 1,000 to 20,000 Da.

6. The method of claim 1, wherein the 3-arm epoxide comprises triglycidyl glycerol.

7. The method of claim 1, wherein the hydrogel comprises a self-polymerizing hydrogel.

8. The method of claim 7, wherein the self-polymerizing hydrogel comprises a polyethylene glycol hydrogel or a polyethylene glycol derivative hydrogel.

9. The method of claim 8, wherein the self-polymerizing hydrogel comprises polyethylene glycol triacrylate.

10. The method of claim 7, wherein the crosslinker comprises a 2-arm polyethylene glycol acrylate or a 4-arm polyethylene glycol acrylate.

11. The method of claim 10, wherein the crosslinker has a molecular weight of 1,000 to 20,000 Da.

12. The method of claim 7, wherein the self-polymerizing hydrogel comprises an activating agent and an initiator.

13. The method of claim 12, wherein the activating agent comprises ferrous gluconate.

14. The method of claim 12, wherein the initiator comprises hydrogen peroxide.

15. The method of claim 7, wherein the self-polymerizing hydrogel is adapted to polymerize at room temperature.

16. The method of claim 1, wherein the sensor is a glucose sensor and the sensing layer further comprises a glucose-responsive enzyme.

17. The method of claim 16, wherein the sensing layer comprises a redox mediator.

18. The method of claim 17, wherein the redox mediator comprises a ruthenium-containing complex or an osmium-containing complex.

19. The method of claim 1, wherein the crosslinker is covalently bonded to the swelling modulator.

20. The method of claim 1, wherein the crosslinker has a molecular weight of 1,000 to 20,000 Da and is covalently bonded to the swelling modulator which does not comprise PEG.

21. The method of claim 1, wherein the membrane comprises more than one coating of the hydrogel, crosslinker and swelling modulator.

22. The method of claim 1, wherein collecting data comprises generating signals from the sensor and processing the signals into data.

23. The method of claim 1, wherein the data comprises the signals from the sensor.

24. The method of claim 1, further comprising activating an alarm if the data indicates an alarm condition.

25. The method of claim 1, further comprising administering a drug in response to the data.

26. The method of claim 25, wherein the drug is insulin.

27. The method of claim 26, further comprising obtaining a calibration value from a calibration device to calibrate the data.

28. The method of claim 27, wherein the calibration device is coupled to the display unit.

29. The method of claim 28, further comprising transmitting the calibration value from a transmitter in the display unit to a receiver in a sensor control unit, wherein the sensor control unit is integrated with the sensor.

\* \* \* \* \*

专利名称(译)	分析物传感器包括水凝胶膜		
公开(公告)号	<a href="#">US9668685</a>	公开(公告)日	2017-06-06
申请号	US14/719820	申请日	2015-05-22
[标]申请(专利权)人(译)	雅培糖尿病护理公司		
申请(专利权)人(译)	雅培糖尿病INC.		
当前申请(专利权)人(译)	雅培糖尿病INC.		
[标]发明人	BOMMAKANTI BALASUBRAHMANYA S SANDHU GARY HOSS UDO		
发明人	BOMMAKANTI, BALASUBRAHMANYA S. SANDHU, GARY HOSS, UDO		
IPC分类号	A61B5/05 A61B5/00 A61B5/1473 A61B5/145 A61B5/1495 A61B5/1486		
CPC分类号	A61B5/14865 A61B5/0004 A61B5/1473 A61B5/1486 A61B5/1495 A61B5/14532 A61B5/4839 A61B5/742 A61B5/746 A61B5/145		
代理机构(译)	BOZICEVIC , FIELD & FRANCIS LLP		
其他公开文献	US20150250412A1		
外部链接	<a href="#">Espacenet</a> <a href="#">USPTO</a>		

摘要(译)

通常，本公开的实施方案涉及分析物确定方法和装置（例如，电化学分析物监测系统），其通过包含包含水凝胶，交联剂和溶胀调节剂的涂层而具有改善的信号响应和稳定性，其中涂层是设置在体内和/或体外分析物传感器的工作电极附近，例如，使用分析物传感器和/或测试条进行连续和/或自动体内监测。还提供了在分析物监测中使用例如电化学分析物传感器的系统和方法。

Formulation 10Q5

