



US 20170296114A1

(19) **United States**

(12) **Patent Application Publication**
Ghaffari et al.

(10) **Pub. No.: US 2017/0296114 A1**
(43) **Pub. Date: Oct. 19, 2017**

(54) **METHOD AND SYSTEM FOR MEASURING PERSPIRATION**

A61B 5/00 (2006.01)
A61B 5/00 (2006.01)

(71) Applicant: **MC10, Inc.**, Lexington, MA (US)

(52) **U.S. Cl.**
CPC *A61B 5/4266* (2013.01); *A61B 5/6833* (2013.01); *A61B 5/002* (2013.01); *A61B 5/14517* (2013.01); *A61B 5/14539* (2013.01)

(72) Inventors: **Roozbeh Ghaffari**, Cambridge, MA (US); **Gilbert Lee Huppert**, Stoneham, MA (US); **Brian Murphy**, Medford, MA (US); **Isaiah Kacyvenski**, Weston, MA (US)

(57) **ABSTRACT**

A perspiration sensing system includes a sensor patch and a smart device. The sensor patch includes one or more perspiration sensing portions. The one or more perspiration sensing portions include an inlet having a predefined size to receive perspiration from a predefined number of sweat glands and an outlet for reducing back pressure. At least one perspiration sensing portion includes a channel having a colorimetric sensing material that changes color when exposed to perspiration. At least one perspiration sensing portion includes a colorimetric assay in a substrate that changes color when exposed to biochemical components of perspiration. The system further includes a smart device having a camera that can take a picture of the sensor patch and determine the volume, rate of perspiration, and/or biochemical components of the perspiration from the one or more perspiration sensing portions.

(21) Appl. No.: **15/491,379**

(22) Filed: **Apr. 19, 2017**

Related U.S. Application Data

(60) Provisional application No. 62/324,723, filed on Apr. 19, 2016.

Publication Classification

(51) **Int. Cl.**
A61B 5/00 (2006.01)
A61B 5/145 (2006.01)
A61B 5/145 (2006.01)

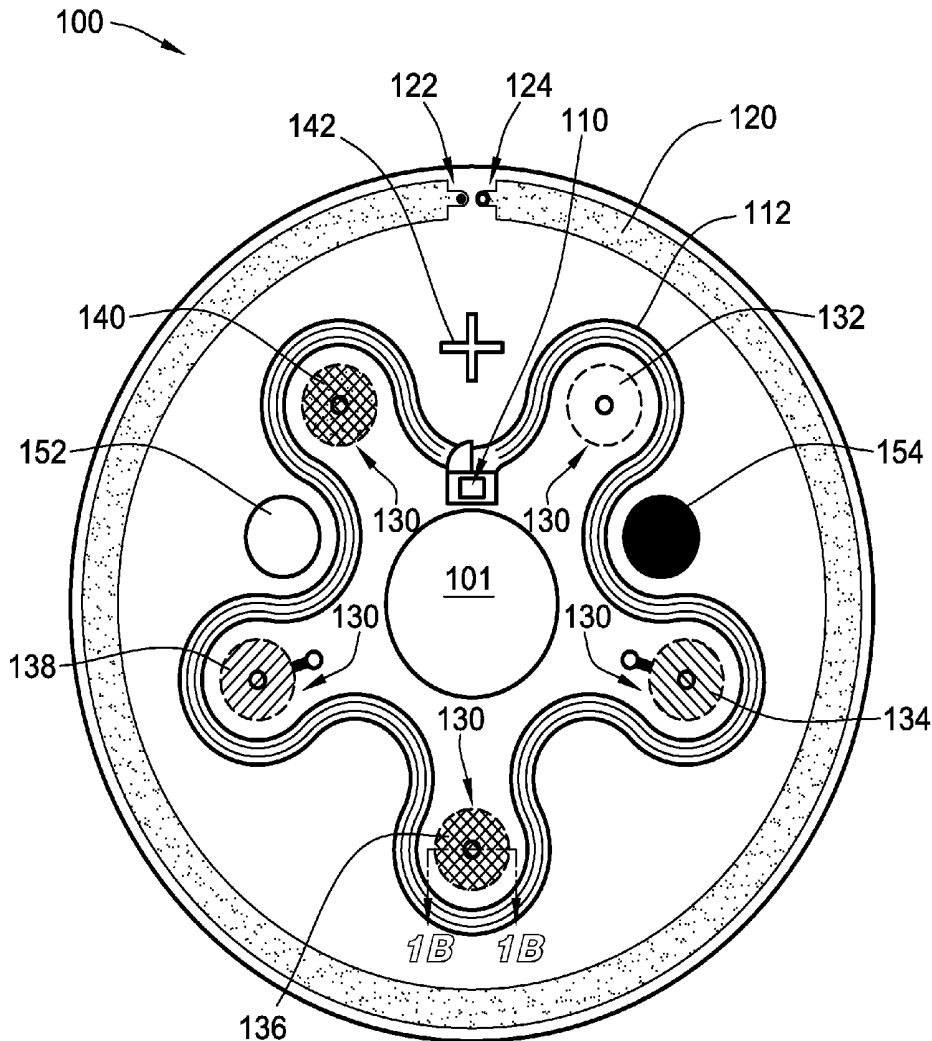

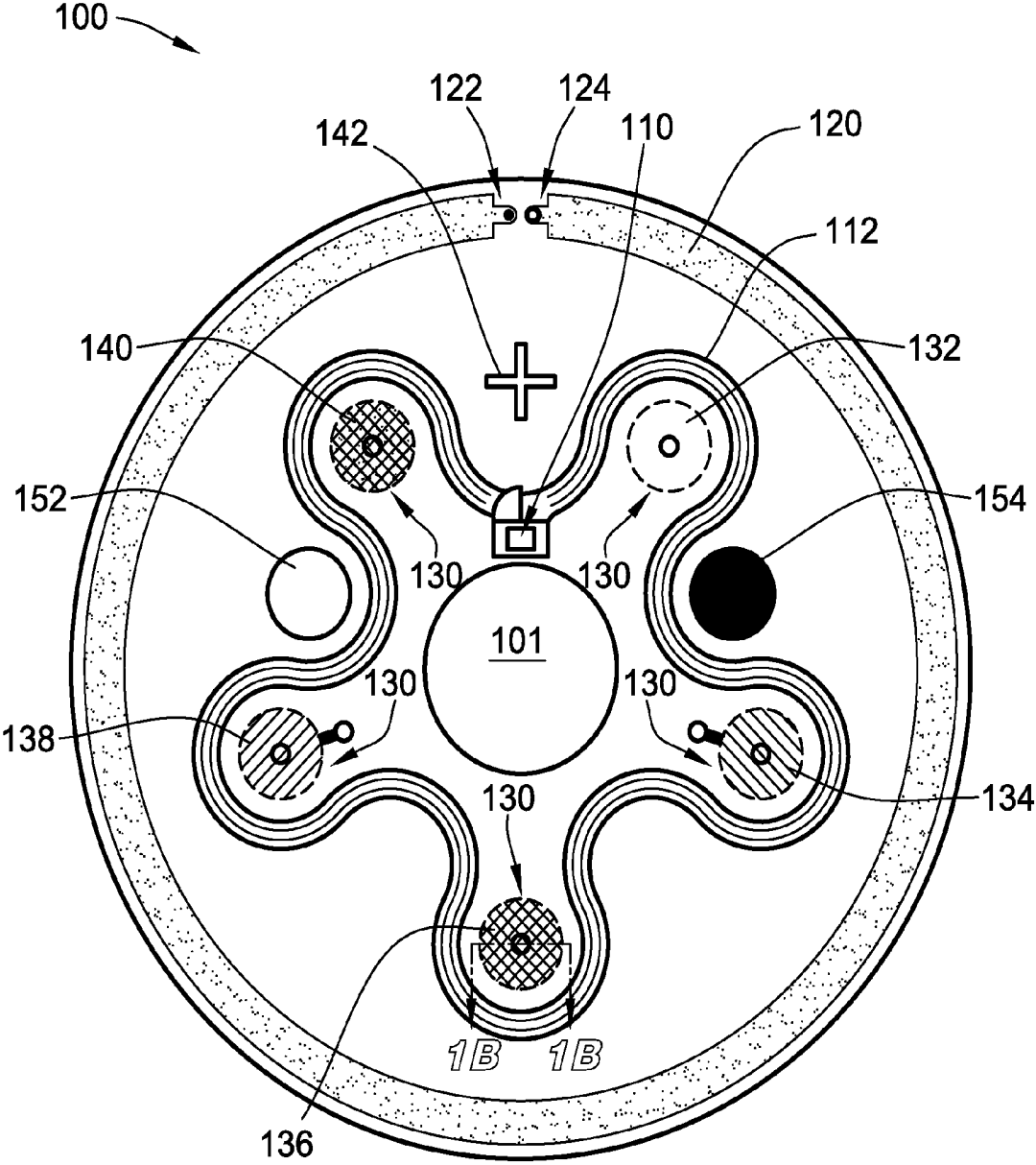

FIG. 1A

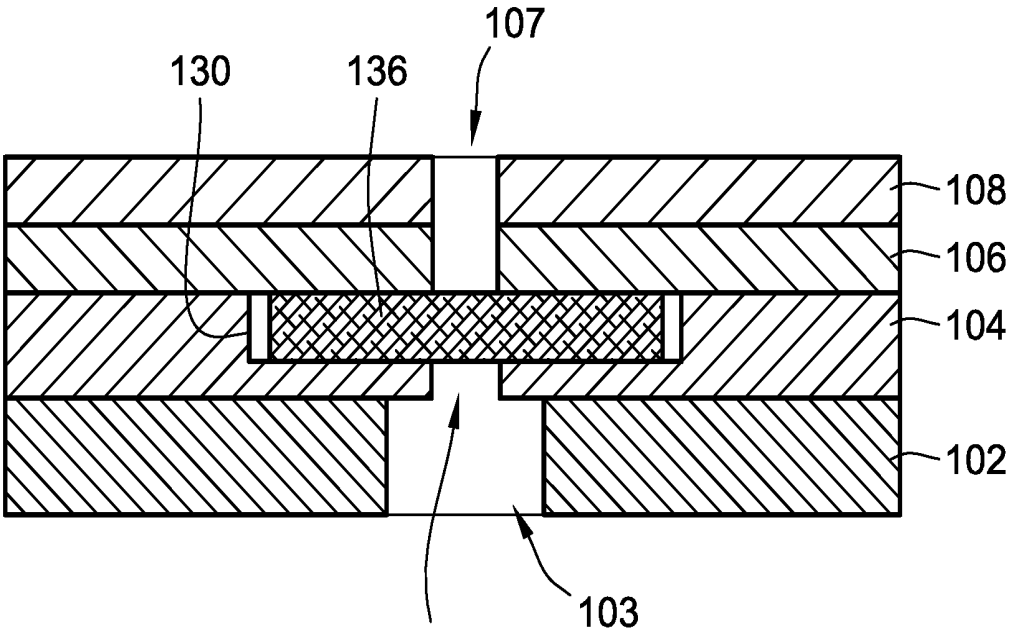

FIG. 1B

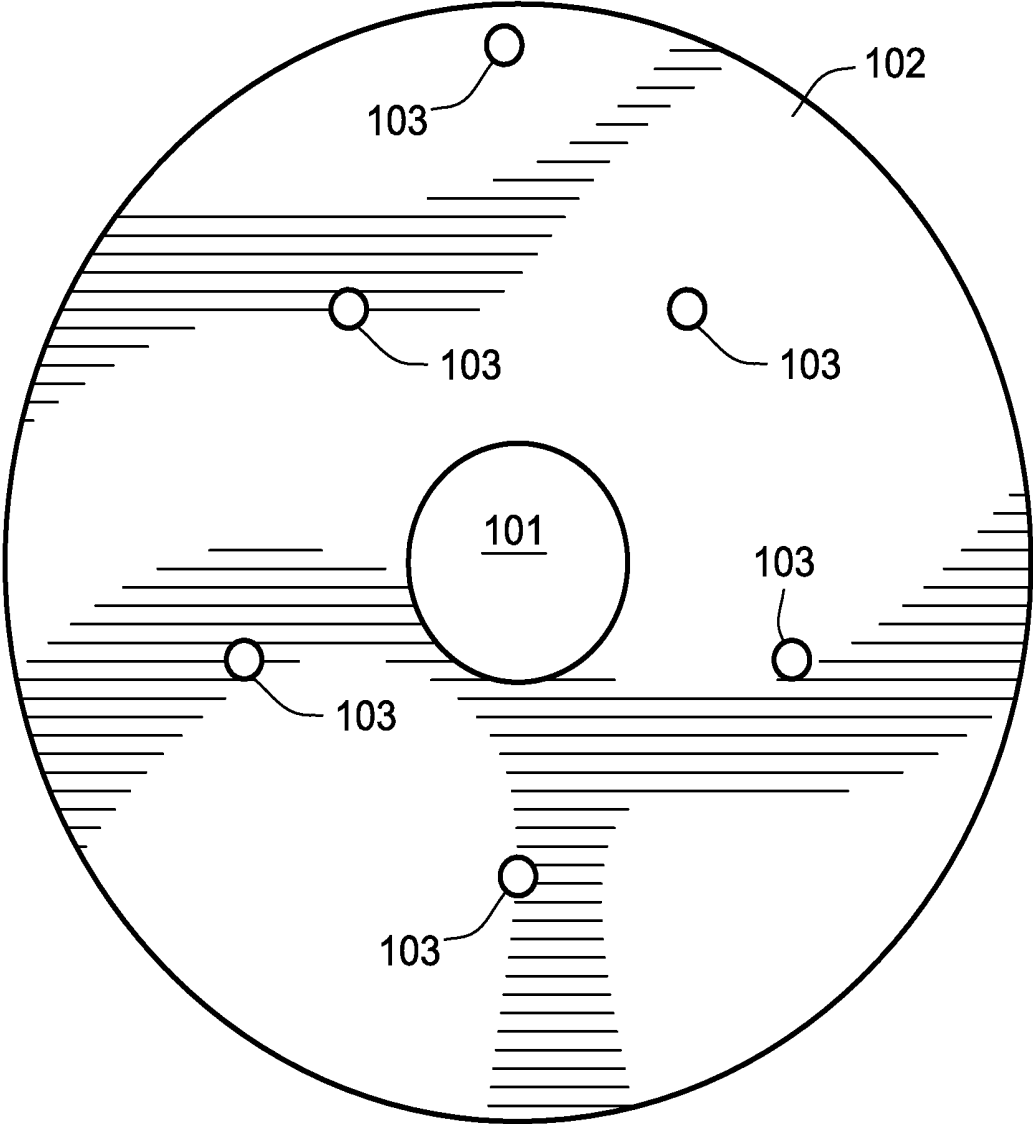

FIG. 2A

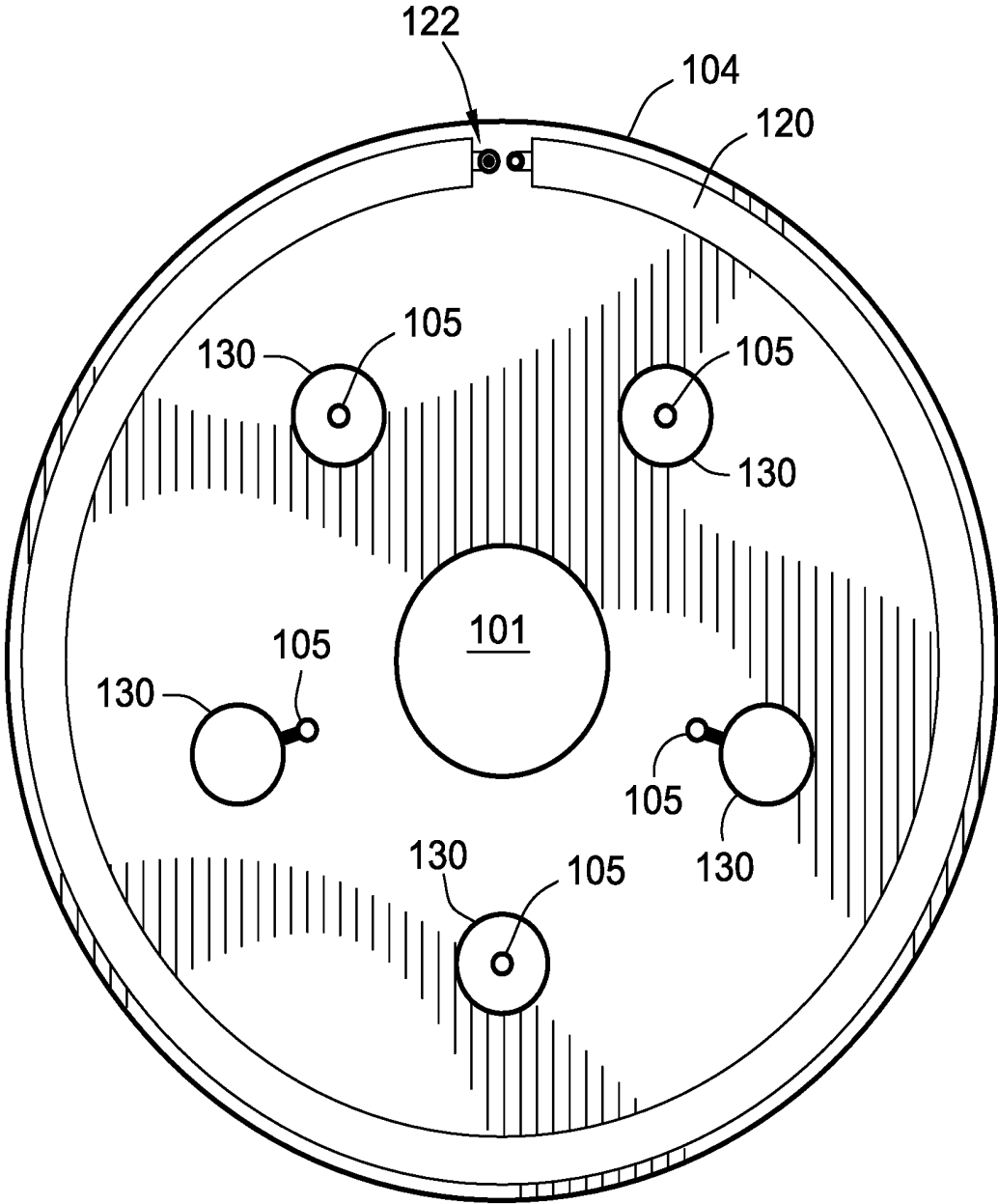

FIG. 2B

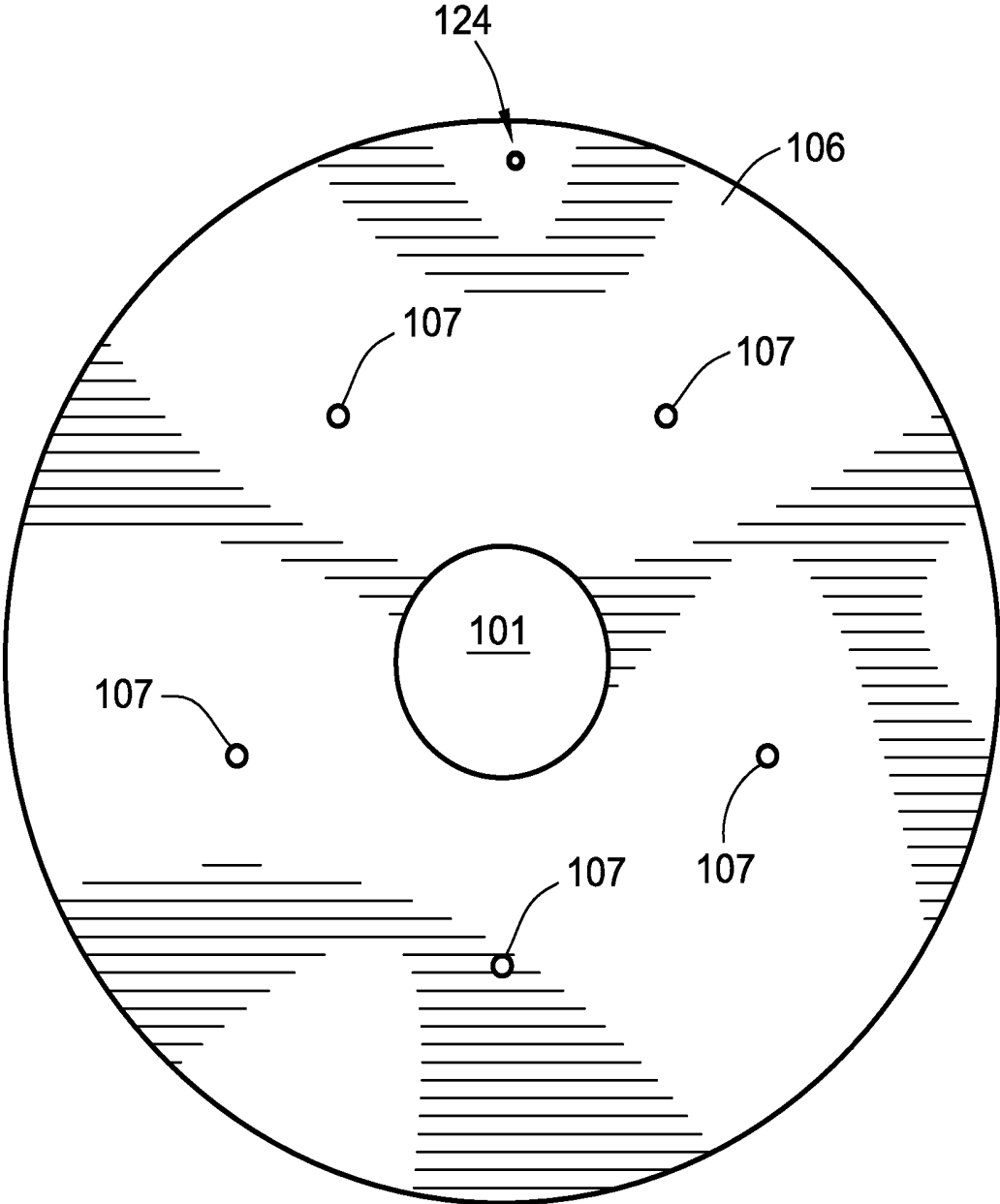

FIG. 2C

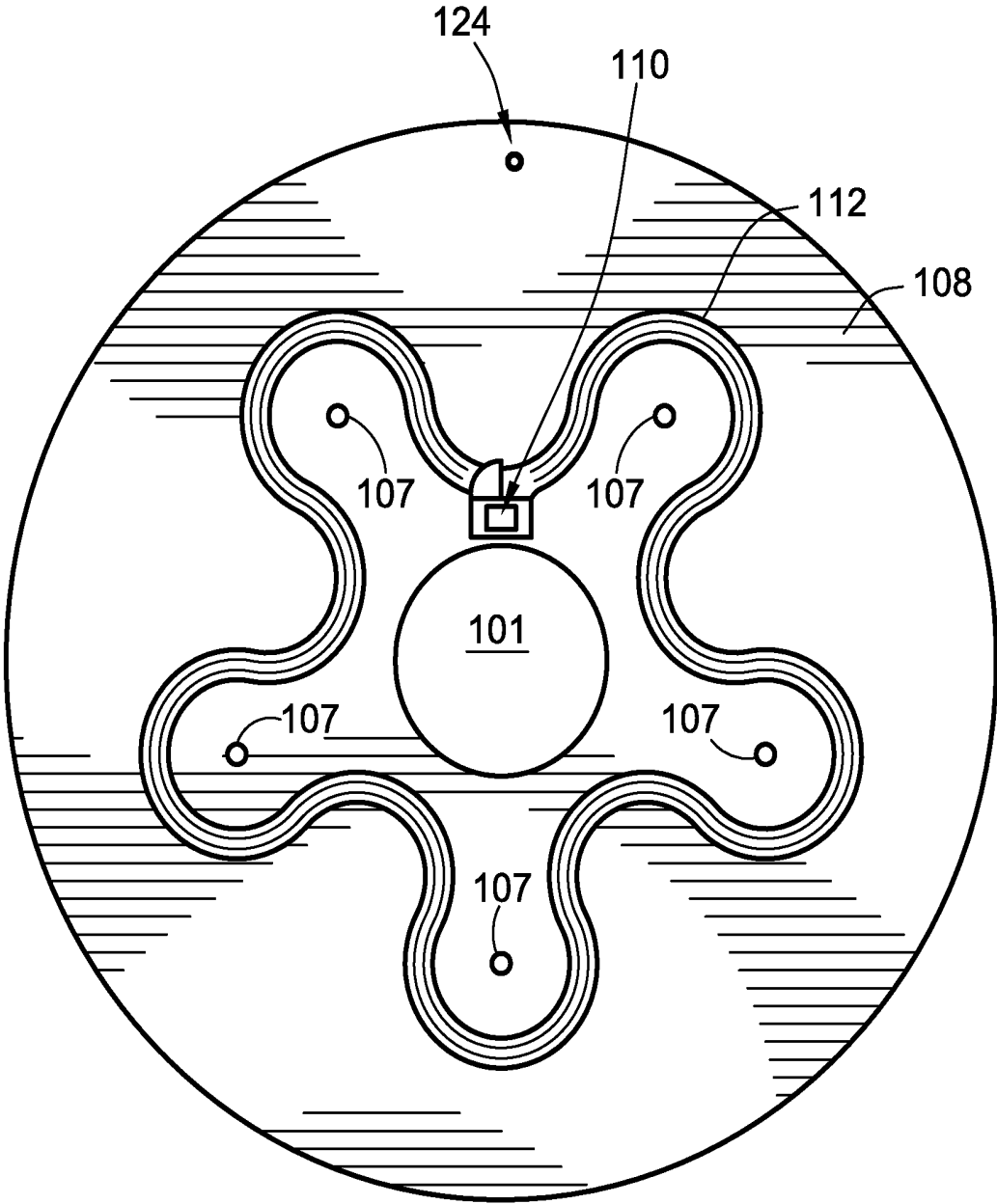

FIG. 2D

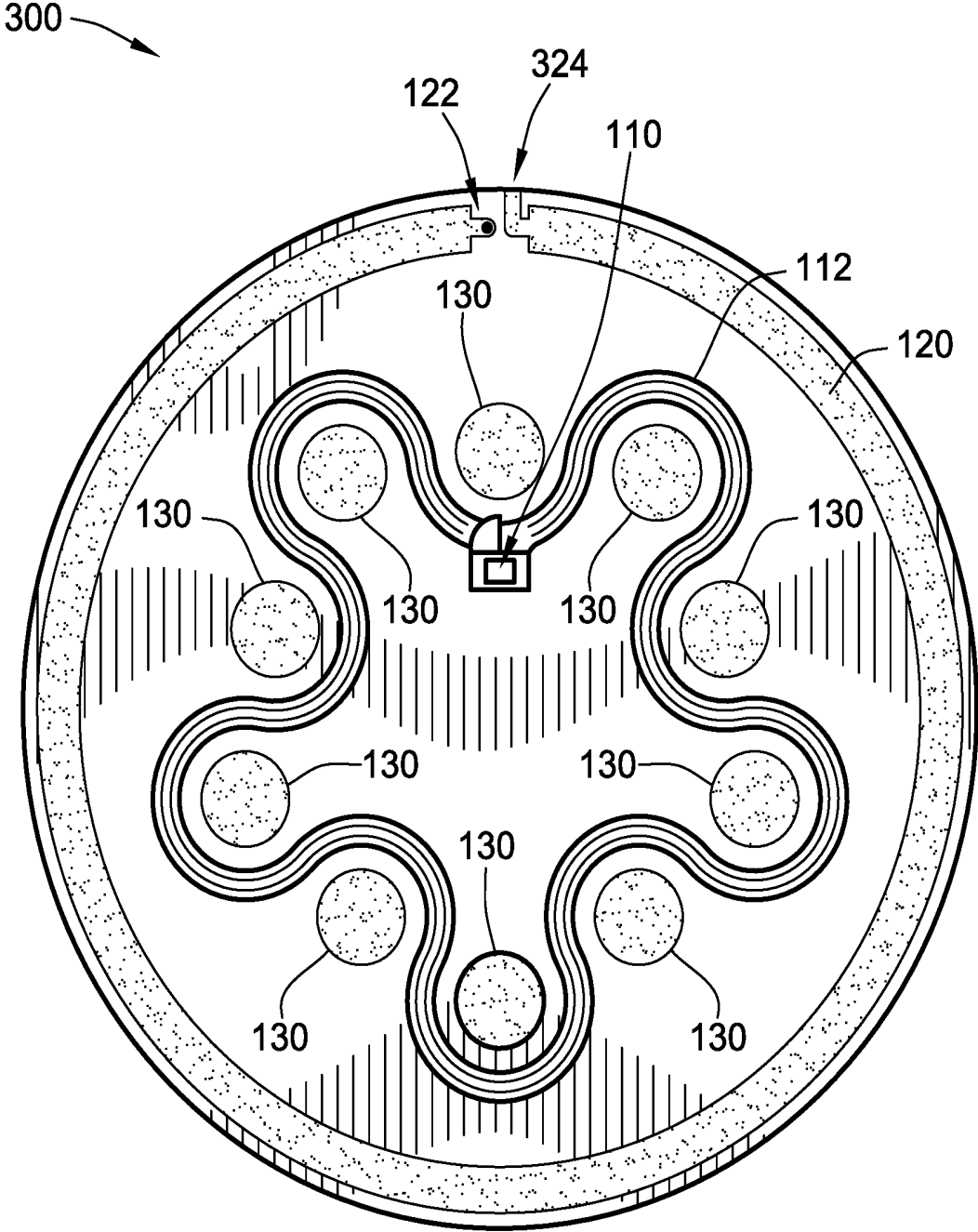

FIG. 3

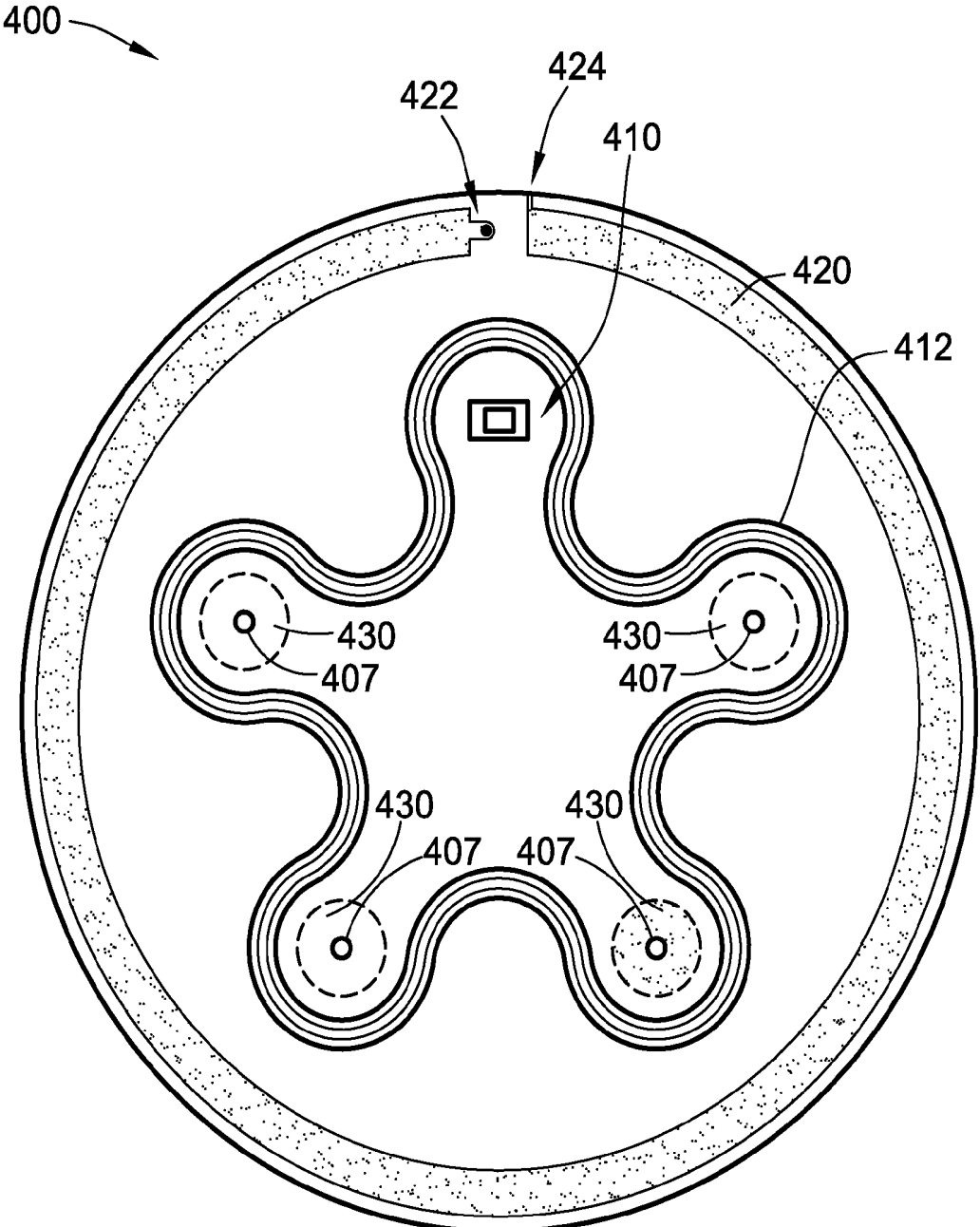

FIG. 4

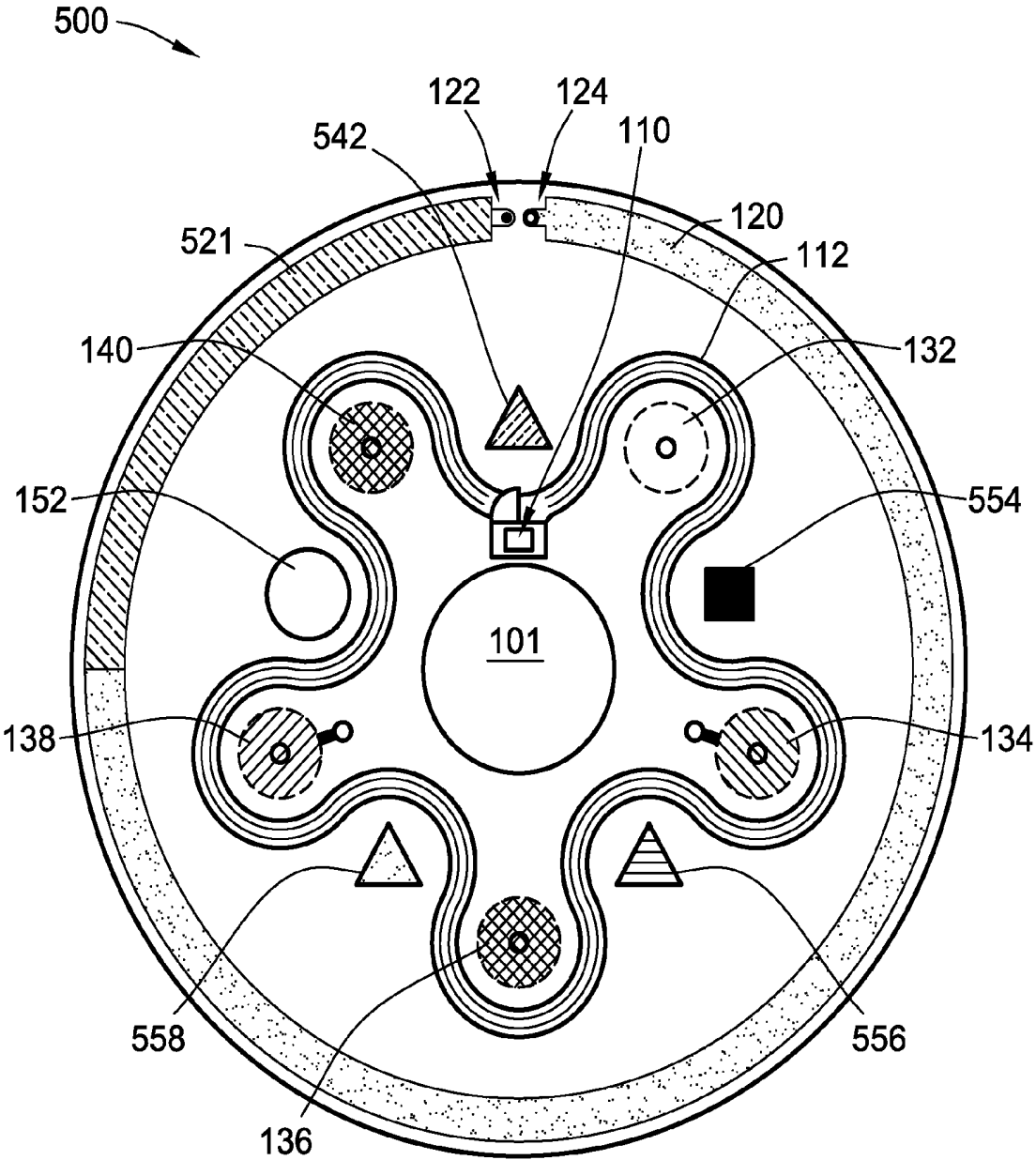

FIG. 5

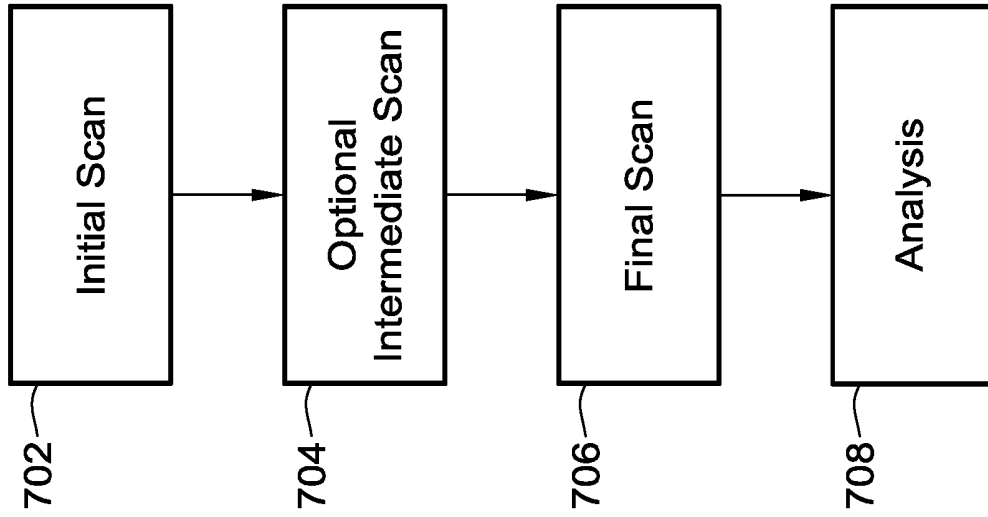

FIG. 7

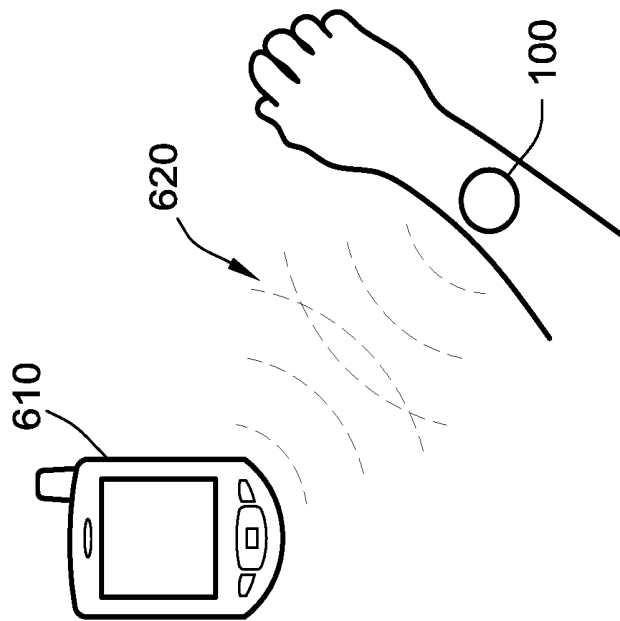

FIG. 6

METHOD AND SYSTEM FOR MEASURING PERSPIRATION

CROSS-REFERENCE TO RELATED APPLICATIONS

[0001] The present application claims the benefit of and priority to U.S. Provisional Application No. 62/324,723, filed Apr. 19, 2016, entitled, "METHOD AND SYSTEM FOR MEASURING PERSPIRATION," which is hereby incorporated by reference herein in its entirety.

BACKGROUND

Technical Field of the Invention

[0002] The present invention is directed to methods and systems for measuring perspiration. More specifically, the present invention is directed to methods and systems for quantitatively measuring the volume and rate of perspiration as well as quantitatively measuring biochemical elements found in perspiration.

Description of the Prior Art

[0003] Typical systems for measuring perspiration or sweat are found in laboratories that collect perspiration in highly controlled environments and perform subsequent analyses using conventional chemical analysis techniques such as mass spectroscopy and biochemical assays.

SUMMARY

[0004] The present invention is directed to methods and systems for quantitatively determining the volume and rate of perspiration, and for detecting and quantitatively determining specific biochemical elements present in perspiration of a user.

[0005] In accordance with implementations of the invention, a sensor patch can include a perspiration volume sensing channel and a perspiration component sensing chamber. The channel can include at least a first colorimetric material that changes color in response to exposure to perspiration. The chamber can include at least a second colorimetric material that changes color in response to exposure to a biochemical component in the perspiration. The patch can include a near field communication circuit.

[0006] In accordance with implementations of the invention, a method of using a smart device and a sensor patch placed on a surface of a user to determine one or more properties of perspiration from the user includes causing the smart device to interrogate a near field communication circuit of the sensor patch. The near field communication circuit (NFC) and/or the NFC antenna can be included in a near field communication chip or other integrated circuit chip or device. The method further includes executing a function on the smart device to obtain at least one image of the sensor patch based on data sent from the near field communication circuit in response to the interrogation. The method further includes analyzing the at least one image to determine a volume of the perspiration, a rate of the perspiration, one or more components within the perspiration, or a combination thereof.

[0007] In accordance with implementations of the invention, a sensor patch includes at least one perspiration sensing portion and a near field communication circuit. The portion can include at least one colorimetric material that changes

color in response to perspiration. The near field communication circuit (NFC) and/or the NFC antenna can be included in a near field communication chip or other integrated circuit chip or device. The near field communication circuit can be configured to cause a smart device to execute a function on the smart device based on data sent from the near field communication circuit in response to interrogation of the near field communication circuit by the smart device.

[0008] These and other capabilities of the invention, along with the invention itself, will be more fully understood after a review of the following figures, detailed description, and claims.

BRIEF DESCRIPTION OF THE FIGURES

[0009] The patent or application file contains at least one drawing executed in color. Copies of this patent or patent application publication with color drawing(s) will be provided by the Office upon request and payment of the necessary fee.

[0010] The accompanying drawings, which are incorporated into this specification, illustrate one or more exemplary embodiments of the inventions and, together with the detailed description, serve to explain the principles and applications of these inventions. The drawings and detailed description are illustrative, and are intended to facilitate an understanding of the inventions and their application without limiting the scope of the invention. The illustrative embodiments can be modified and adapted without departing from the spirit and scope of the inventions.

[0011] FIG. 1A shows a diagrammatic top view of a sensor patch 100 according to some embodiments of the invention;

[0012] FIG. 1B shows a diagrammatic view of the stack-up of the layers of a sensor patch according to some embodiments of the invention;

[0013] FIG. 2A shows a diagrammatic view of the adhesive layer according to some embodiments of the invention;

[0014] FIG. 2B shows a diagrammatic view of the bottom layer according to some embodiments of the invention;

[0015] FIG. 2C shows a diagrammatic view of the top layer according to some embodiments of the invention;

[0016] FIG. 2D shows a diagrammatic view of an alternative top layer according to some embodiments of the invention;

[0017] FIG. 3 shows a diagrammatic view of a sensor patch according to some embodiments of the invention;

[0018] FIG. 4 shows a diagrammatic view of a sensor patch according to some embodiments of the invention;

[0019] FIG. 5 shows a diagrammatic view of a sensor patch in use according to some embodiments of the invention;

[0020] FIG. 6 shows a diagrammatic view of a system including a sensor patch and a smart device according to some embodiments of the invention; and

[0021] FIG. 7 shows a diagrammatic view of a method of using a sensor patch according to some embodiments of the invention.

DETAILED DESCRIPTION OF PREFERRED EMBODIMENTS

[0022] The present invention is directed to methods and systems for quantitatively determining the volume and rate of perspiration, and for detecting and quantitatively determining specific biochemical elements present in perspiration

of a user. The system can include a sensor patch adhered to the body and a mobile device, such as a smart phone. The method can include taking an image (e.g., a photograph or video) of the sensor patch prior to beginning the activity that results in perspiration and then taking an image (e.g., a photograph or video) of the sensor patch prior to during or after completing the activity that results in perspiration. A comparison of the images, including images of various sections of the sensor patch can be used to determine, quantitatively, the volume and rate of perspiration as well as detect the presence and amount of biochemical components, such as sodium ions, chloride ions, glucose, and lactate in the perspiration. The pH and other chemical properties of the perspiration can also be detected.

[0023] FIG. 1A shows a diagrammatic top view of a sensor patch 100 according to some embodiments of the invention. The sensor patch 100 can include a near field communication (NFC) IC chip 110 (which can include an NFC circuit and/or an NFC antenna 112), a perspiration volume (and rate) sensing channel 120, and one or more sensing chambers 130 for detecting and quantifying biochemical components of perspiration and/or pH. Although, in some embodiments of the invention, one of the perspiration volume sensing channel 120 or the one or more sensing chambers 130 can be omitted. A biocompatible adhesive layer (FIG. 2A) can be used to adhere the sensor patch 100 to the skin, although, the patch 100 can be integrated into a layer of clothing to hold it in position without the need for adhesives. The sensor patch 100 can also include printed indicia, including registration marks 142 and color reference marks 152, 154, to facilitate imaging of the sensor patch 100. The central section of the sensor patch 100 can include an opening or hole 101 to reduce the amount of skin surface area being covered and allow perspiration to escape.

[0024] As discussed above, the sensor patch 100 also can include multiple sensing portions for detecting and quantifying components of a fluid and/or parameters (e.g., pH) within a fluid. In preferred embodiments of the invention, the fluid can be perspiration of a user on which the sensor patch 100 is placed and the components can be one or more biological components. In some embodiments of the invention, the sensing portions can include a perspiration volume (and rate) sensing channel 120 for detecting the volume and/or rate of perspiration. The sensing portions can also include one or more sensing chambers 130 for detecting and quantifying biochemical components of perspiration and/or biochemical parameters (e.g., pH).

[0025] The perspiration volume sensing channel 120 can be a single channel. Alternative, the perspiration volume sensing channel 120 can include multiple perspiration channels. The perspiration volume sensing channel 120 can include a colorimetric coating that changes color in the presence of perspiration. In some embodiments, the coating can be, for example, silver chloranilate. One surface of the sensor patch 100 can be configured to contact the surface (e.g., skin) of a user and can include a channel inlet port 122 that is in fluidic communication with the one or more perspiration channels. The channel inlet port 122 allows perspiration flow from the skin of the user to the one or more channels of the perspiration volume sensing channel 120. A channel vent port 124 can optionally be provided to reduce the backpressure within the perspiration volume sensing channel 120 as the perspiration flows into the perspiration volume sensing channel 120.

[0026] The sensor patch 100 as a whole, or one or more layers of the sensor patch 100, can be formed of a transparent material that enables the user to see the color change through the top of the sensor patch 100. The color change starts at the area of the perspiration volume sensing channel 120 closest to the channel inlet port 122 and advances with time toward the channel vent port 124. Based on the known volume of the perspiration volume sensing channel 120 and the length of the color change in the perspiration volume sensing channel 120, a measure of the volume of perspiration can be determined. Based on the elapsed time from a first point in time, such as the beginning of the perspiration entering the perspiration volume sensing channel 120, to a later point in time, such as when the perspiration reaches the vent port 124 or any point along the perspiration volume sensing channel 120, the rate of perspiration can be determined.

[0027] While the perspiration volume sensing channel 120 is shown as following the outer perimeter of the sensor patch 100, the perspiration volume sensing channel 120 can be any shape, including a straight line or set of straight lines, a zigzag shape, a serpentine shape, a spiral pattern, or a combination of different shapes and/or patterns. The perspiration volume sensing channel 120 can also be on any area of the sensor patch 100, not necessarily the perimeter. Longer or shorter patterns can be provided depending on the desired longer or shorter useful life of the perspiration volume sensing channel 120 and/or sensor patch 100.

[0028] The sensing chambers 130 can be used to detect and measure the quantity of various biochemical components found in and/or properties of (e.g., pH) the user's perspiration. Each sensing chamber 130 can include one or more inlet ports (shown in FIG. 2B) that enable perspiration to enter the sensing chambers 130 and a vent port (shown in FIGS. 2C and 2D) that reduce the back pressure within the sensing chambers 130. Each sensing chamber 130 can include an absorbent substrate material (e.g., cellulose or fabric) that carries a colorimetric assay or color sensitive material 132, 134, 136, 138, and 140 that changes color in response to the presence of a biochemical component, such as sodium ions, chloride ions, glucose, lactate, alcohol, potassium, or in response to a property of the perspiration, such as the pH of the perspiration. Other colorimetric assays, such as for detecting illegal drugs or biomarkers indicative of illegal drug use can also be used. The absorbent substrate material can be formed from one or more of the following materials, including porous absorbent paper, open-cell or closed-cell foam, woven or non-woven fabrics, microfiber cloth, and nano-fiber mesh.

[0029] The sensor patch 100 can be constructed of individual layers of stretchable and/or flexible polymeric biocompatible materials, such as silicone elastomers (e.g., PDMS), polyurethane, polyimide and acrylic adhesive materials. Low modulus of elasticity formulations (less than 2 MPa) of these materials can be used to create a very thin sensor patch 100 having a thickness of less than about 2 mm and preferably in the range from about 250 μm to about 1000 μm . Various areas can be functionalized to improve performance of the sensor patch 100. For example, the inlet port 122 described above (and those described below) can include an absorbent material or coating that attracts perspiration (e.g., hydrophilic material or coating, such as PEG, cellulose, or paper).

[0030] A biocompatible adhesive layer can be used to adhere the sensor patch 100 to the skin, although, the sensor patch 100 alternatively can be integrated into a layer of clothing to hold it in position without the need for adhesives.

[0031] FIG. 1B shows a cross-sectional view along the line 1B-1B in FIG. 1A according to some embodiments of the invention. The adhesive layer 102 can include one or more inlet ports 103 that align with inlet ports 105 in the bottom layer 104. The bottom layer 104 can be etched or embossed to include one or more sensing chambers 130 and the sensing chambers 130 can include colorimetric sensing substrate materials 132, 134, 136, 138, and 140 that change color or color intensity upon coming in contact with pre-defined components of perspiration, such as salts (e.g., sodium ions, chloride ions), glucose, and lactate, to name just a few examples. The top layer 106 can be bonded to the bottom layer 104 using an adhesive layer or by plasma bonding (e.g., plasma oxygen bonding). The NFC layer 108 can be bonded to the top layer 106 using an adhesive or plasma bonding. Both the top layer 106 and the NFC layer 108 can include holes for vent ports 107 to reduce the back pressure. The vent ports 107 can be etched or embossed into the layers 106, 108 to form channels that extend to the edges of the sensor patch 100.

[0032] The stack-up can be assembled using various methods. Each of the individual layers can be fabricated using a roll-to-roll or reel-to-reel fabrication process. For example, the adhesive layer 102 can be fabricated on a roll-to-roll web (e.g., n sensor patches across) and the outer margins and the inlet ports 103 can be die cut or laser cut to remove those sections from the web. Similarly, the bottom layer 104 and the layers 106, 108 can be fabricated on a roll-to-roll web (e.g., n sensor patches across) and the outer margins and the vent ports 107 can be die cut or laser cut to remove those sections from the web. The features (e.g., the perspiration volume sensing channel 120 and the sensing chambers 130) can be embossed, laser etched or micro-molded into the polymer layer on the web. Final assembly can include roll-to-roll transfer of each of the layers of the stack-up onto either the adhesive layer 102 or the top layer 106 or NFC layer 108. Where the final assembly stacks the layers on the adhesive layer 102, the color reference marks 152, 154 can be printed on the top layer 106 or the NFC layer 108 after assembly. Where the final assembly stacks the layers on the top layer 106 or NFC layer, the top layer 106 or NFC layer 108 can be pre-printed with the color reference marks 152, 154 prior to assembly.

[0033] FIGS. 2A-2D show diagrammatic views of the individual layers that can be used to construct the sensor patch 100 according to some embodiments of the invention. FIG. 2A shows a diagrammatic view of an adhesive layer 102. The adhesive layer 102 aids in adhering the sensor patch 100 to a user, such as to the skin of a user. In some embodiments of the invention, the adhesive layer 102 can be considered a layer of the sensor patch 100. Alternatively, the adhesive layer 102 can be considered a separate and distinct layer from the sensor patch 100, such as when the sensor patch 100 does not come with an adhesive layer 102.

[0034] The adhesive layer 102 can include a plurality of ports 103. The ports 103 allow perspiration to cross through the adhesive layer 102 and enter the sensor patch 100 or one or more additional layers of the sensor patch 100, discussed below. One or more of the ports 103 can align with the inlet port 122 discussed above. In addition, one or more of the

ports 103 can align with other holes and/or ports discussed below (FIG. 2B). The ports 103 can be in the range from about 1 mm to about 5 mm in diameter depending on the desired volume of perspiration to be collected at the associated inlet port. In accordance with some embodiments, a single port 103 in the adhesive layer 102 can be open to all the ports within the above layers (such as the bottom layer 104 discussed below). In this configuration, motion of the un-adhered portion(s) of sensor patch 100 caused by physical activity can provide for pumping of perspiration into the inlet ports.

[0035] The adhesive layer 102 can be formed of any compatible adhesive material preferably strong enough to adhere the sensor patch 100 to the skin of the user when it is wet, dirty, and/or includes substantial amounts of hair. Examples of these adhesives include individual or combinations of adhesives selected from the group consisting of silicone gel adhesive, a silicone pressure sensitive adhesive, an acrylic pressure sensitive adhesive, a natural or synthetic rubber adhesive, and hydrocolloid adhesives. However, any type of pressure sensitive adhesive, permanent adhesive, and/or removable adhesive element, such as an adhesive tape, can be used.

[0036] The adhesive layer 102 can also include an absorbent, wicking, or hydrophilic material that captures perspiration as it enters the ports 103 and directs the captured perspiration toward the inlet ports. The absorbent, wicking, or hydrophilic material can include one or more of the following materials: porous absorbent paper, open-cell or closed-cell foam, woven or non-woven fabrics, microfiber cloth, and nano-fiber mesh.

[0037] FIG. 2B shows a diagrammatic view of the bottom layer 104 of the sensor patch 100. The description of the bottom layer 104 as the “bottom” layer is merely for convenience of explanation and is not meant to be limiting. For example, in some embodiments of the invention where the adhesive layer 102 is considered part of the sensor patch 100, the adhesive layer 102 can be considered the “bottom” layer and the bottom layer 104 as described herein can be one of the middle layers of the sensor patch 100.

[0038] The bottom layer 104 can include the features of the sensor patch 100 including one or more perspiration channels forming the perspiration volume sensing channel 120 and/or the one or more sensing chambers 130. The bottom layer 104 can also include the inlet ports 122 and/or one or more inlet ports 105 that enable perspiration to enter the perspiration volume sensing channel 120 and the sensing chambers 130, respectively.

[0039] The size of the inlet ports 122, 105 can be determined based on the desired operation of the sensor patch 100. For example, using the known pore density on the skin, the size of the inlet ports 122, 105 can be selected to expose a predefined number of sweat glands to each inlet port and then the size of perspiration volume sensing channel 120 and the sensing chambers 130 can be determined based on the sensitivity of colorimetric coatings, assays, and materials to achieve the desired performance. In accordance with some embodiments, the inlet ports 122, 105 can be in the range of about 0.25 mm to about 1 mm or more, depending on the desired amount of perspiration collection. Using the adhesive layer 102, the inlet ports 122, 105 are sealed to the skin enabling the sweat gland to pump perspiration into the inlet ports 122, 105 and then using pressure and capillary action, the perspiration flows into the perspiration volume sensing

channel 120 and the sensing chambers 130. In accordance with some embodiments, hydrophilic, absorbent, and/or wicking materials can be included in the inlet ports 122, 105, the perspiration volume sensing channel 120, and the sensing chambers 130 to aide in the flow of perspiration to the desired locations within the sensor patch 100.

[0040] In accordance with some embodiments, the bottom layer 104 can be formed by combining two or more layers of material, one layer including the inlet ports 122, 105 and the other layer defining the features (e.g., the perspiration volume sensing channel 120 and sensing chambers 130). Alternatively, the inlet ports 122, 105 and the features can be laser micro-molded, die cut, etched, and/or embossed into the bottom layer. The bottom layer can be in the range from about 200 μm to about 700 μm in thickness and the features can be in the range from about 100 μm to about 500 μm deep into the bottom layer 104.

[0041] FIG. 2C shows a diagrammatic view of the top layer 106 of the sensor patch 100. The description of the top layer 106 as the “top” layer is merely for convenience of explanation and is not meant to be limiting. For example, in some embodiments of the invention where the layer 108 (discussed below) is present on the sensor patch 100, the layer 106 can be considered the “top” layer and the top layer 106 as described herein can be one of the middle layers of the sensor patch 100.

[0042] FIG. 2C shows the top layer 106 which includes the vent ports 124, 107. The vent ports 124, 107 reduce the back pressure by connecting the perspiration volume sensing channel 120 and the sensing chambers 130 to the outside environment above the sensor patch and enable air to escape as the perspiration flows into the perspiration volume sensing channel 120 and the sensing chamber 130. The vent ports 124, 107 can be in the range from about 50 μm to about 250 μm in diameter depending on the desired perspiration flow. The top layer 106 can be in the range from about 100 μm to about 400 μm thick.

[0043] FIG. 2D shows an NFC layer 108, which is similar to the top layer 106 but includes the NFC chip 110 and the NFC antenna 112. In this embodiment, the NFC antenna 112 can be fabricated directly on a silicone elastomeric or polyimide substrate that can be die cut or laser etched to include the vent ports 124, 107. The NFC layer 108 can be in the range from about 100 μm to about 400 μm thick.

[0044] FIG. 3 shows an alternative embodiment of a sensor patch 300 according to some embodiments of the invention. In this embodiment, more sensing chambers 130 are provided as compared to the sensor patch 100. Each of the sensing chambers 130 can include a different colorimetric assay or color changing material to enable the sensor patch 300 to detect many different components of perspiration. Alternatively, two or more of the sensing chambers 130 can be configured with the same colorimetric assay or color changing material to provide multiple sensors for quantifying a specific component of perspiration.

[0045] FIG. 3 also shows an alternative vent port 324 configuration. In this configuration, the vent port 324 extends out of the side edge of the sensor patch 300. The vent port 324 can be in the range from about 50 μm to about 250 μm in diameter depending on the desired perspiration flow. The port 324 can have other geometries, such as square, rectangular, etc., and have similar dimensions as the diameter discussed above, such as about 50 μm to about 250 μm in length, or arc length of the patch 300, or the like. In

this embodiment, the vent port 324 can be laser etched or embossed into the bottom layer 104 and run to the outer edge of the layer. Where a feature might interfere with the run of the vent port 324 (such as a vent port running from a sensing chamber 130), a relatively large diameter hole (e.g., about 2 mm or more) can be cut or punched into the sensor patch 100. For example, vent ports extending from sensing chambers 130 can run to central hole 101 shown in FIG. 1.

[0046] The inlet ports 122 and the vent ports 324, 107 leading to each of the sensing chambers 130 can be different sizes to measure different rates. For example, sensing material inside a sensing chamber 130 having a large inlet port 103 is likely to become saturated relatively quickly, where as an adjacent sensing chamber 130 having a smaller inlet port 105 is more likely to provide an accurate measure of a sensed component of perspiration over a longer period of time and a comparison of the two sensing chambers 130 can be used to detect changes in the component composition over time (e.g., the change in salt concentration as the user becomes dehydrated).

[0047] FIG. 4 shows an alternative embodiment of a sensor patch 400 according to some embodiments of the invention. The sensor patch 400 can include a NFC integrated circuit chip 410 and an NFC antenna 412, a perspiration volume and rate sensing channel 420 and one or more sensing chambers 430 for detecting and quantifying biochemical components of perspiration and/or pH. A biocompatible adhesive layer can be used to adhere the sensor patch to the skin, although, the patch can be integrated into a layer of clothing to hold it in position without the need for adhesives. The central section of the sensor patch 400 can include an opening or hole (not shown) to reduce the amount of skin surface area being covered and allow perspiration to escape. The perspiration volume and rate sensing channel 420 can extend from inlet port 422 to vent port 424 around the periphery of the sensor patch 400. Each of the sensing chambers 430 can include an inlet port on the bottom (not shown) and a vent port 407 on the top. Reference marks and color reference marks can also be provided (not shown).

[0048] Referring to FIG. 5, in operation, the user places the sensor patch 500 (or any patch disclosed herein) on a predefined location of the body, such as the arm, the leg or the abdomen. As the user begins to perspire, the perspiration will flow into the perspiration volume sensing channel 120 and begin to change the color of the perspiration sensitive coating or assay in the perspiration volume sensing channel 120 as shown in FIG. 6 as shown by the hatched portion 521. In addition, perspiration will flow into the sensing chambers 130 and components of the perspiration will react with the colorimetric assays and materials 132, 134, 136, 138, and 140 in the sensing chambers resulting in a color change of the sensing chambers 130, as shown in FIG. 6. The sensor patch 500 can include printed indicia in the form of registration and color reference marks 152, 542, 554, 556, 558 on the top surface (e.g., the top layer 106 or 108) of the sensor patch 500 that are printed in predefined locations and provide location reference marks and/or color calibration reference marks.

[0049] As shown in FIG. 6, the user can place their smart device 610 (or other sensing device) near the sensor patch 100 on their body and the NFC chip 110 and NFC antenna 112 of the sensor patch 100 will communicate (as represented by the waves 620) with the smart device 610 and cause the smart device 610 to load and execute an applica-

tion that can perform various functions. In accordance with some embodiments, the smart device 610 can load an application that assists the user with acquiring an image (e.g., a photograph or a video) of the sensor patch 100 on his or her body. The application can guide the user to use the camera in the smart device 610 to acquire the image by providing guide marks on the smart device 610 screen to position the sensor patch 100 in the image. The application of the smart device 610 or a remote application (e.g., a cloud based application) can analyze the image of the sensor patch 100 to identify the location reference marks and the color calibration reference marks, e.g., as shown in FIGS. 1 and 5. The registration marks and/or color reference marks 152, 154 can be used to locate each of the sensing chambers 130. The application can use the color reference marks 152, 154 to calibrate the image for white balance and color intensity for the ambient light and then analyze the calibrated image to determine quantitatively the components of the user's perspiration. The image can also be analyzed to determine the volume and rate of perspiration using the perspiration volume sensing channel 120 by determining the portion that has changed color as compared to the overall length of the perspiration volume sensing channel 120.

[0050] In accordance with some embodiments, the NFC chip 110 can include or be connected to a circuit that includes a heating element that can be controlled (e.g., turned on or off, or up or down) through interaction with the NFC chip 110 (e.g., loading a value in a register or memory location). The heating element can provide for local heating in order to induce perspiration with physical activity. Alternatively, the sensor patch 100 can include a battery or other power source to power the heating element without the need to keep the NFC reading device in close proximity.

[0051] In accordance with some embodiments, the NFC chip 110 can include or be connected to a thermistor or other temperature sensor that can be read using NFC communications (e.g., waves 620). The NFC chip can include or be connected to an analog to digital converter that converts the temperature sensor value to a digital value that can be converted to temperature. The temperature sensor can be placed close to the skin to provide a measure of skin surface temperature or insulated from the skin to provide a measure of ambient environmental temperatures. Skin temperature can be used to determine core body temperature as well as to determine vapor pressure and evaporation rates of perspiration and provide warnings to the user about unsafe conditions. The temperature sensor can also be positioned in or near the sensing chambers 130 to provide an indication of the temperature of the colorimetric assays used in the biochemical analysis of perspiration, to determine whether a threshold has been crossed indicating that the assay is no longer usable.

[0052] FIG. 7 shows a flowchart of a method of using the sensor patch 100 with a smart device 610, such as a smart phone according to some embodiments of the invention. After the user places the sensor patch 100 on his or her body and before the user begins the activity that will induce perspiring (e.g., exercise or other physical activity), the user takes an initial scan (box 802) of the sensor patch 100, which results in an initial image of the sensor patch 100 prior to detecting perspiration. Each scan event can include the user placing the smart device 610 near the sensor patch 100 resulting in the NFC activation (e.g., waves 620) of the sensor patch 100 by smart device 610 as the reader and

causing the NFC chip 110 in the sensor patch 100 to execute a function or task. The function can, for example, include the NFC chip 110 sending data (e.g., waves 620) to the smart device 610, which causes the performance of an operation or the execution of a program. The program can, for example, include providing an image with guidelines on the display that helps the user position the sensor patch 100 in an appropriate position to generate one or more images (e.g., by photograph or video). The flash can be used to reduce the impact of ambient lighting and shadows. This image can be compared to later images of the sensor patch 100 to determine the amount and rate of perspiration as well as the component elements of perspiration. After the user begins to perspire, the user or another person can optionally take intermediate scans of the sensor patch 100 during the activity to determine intermediate perspiration readings (box 704). After the user has completed the physical activity, the user can take a final scan (box 706) of the sensor patch 100 using the smart device 610. In addition to recording the image of the sensor patch 100, the smart device 610 can also record other information, such as time and date; environmental temperature, humidity, and/or pressure; and location, including elevation (e.g., using GPS coordinates) for each image. This information can be stored and used to adjust the perspiration data, as well as for other determinations. An application in the smart device 610 can compare and analyze the images to determine the perspiration volume, rates, and/or component information or the application can forward the images to a remote computer (e.g., a cloud based application) to analyze the images and determine the perspiration volume, rates, and/or component information.

[0053] The analysis can include using the location reference marks to orient and scale the images of the sensor patch 100 such that the locations of the perspiration volume sensing channel 120 and locations of the individual sensing chambers 130 can be identified in each image. Next, the analysis can include calibrating the color and brightness of the image to accommodate a broad range of ambient light conditions and different camera color calibrations using the color calibration reference marks. The calibrated images can be used to determine the perspiration volume and component information.

[0054] From the perspiration volume sensing channel 120, the length of the color change can be correlated to a volume of perspiration as function of the known volume of the perspiration volume sensing channel 120 (e.g., the cross-sectional area times the length of the color change area) provides a measure of the perspiration volume. The perspiration rate can be determined by time between scans, which can be calculated from the date and time stamps of the images (e.g., from the operating system or the meta-data of the images).

[0055] For the sensing chambers 130, the location of each chamber can be determined in the calibrated image and a color value (e.g., in RGB or color value, hue, and saturation) can be determined for each location of each sensing chamber 130. Based on the known location, the color value can be compared to a reference table that provides a quantitative indication of the detected component of perspiration for that sensing chamber 130. Depending on the assay or the color sensitivity of the assay material 132, 134, 136, 138, and 140 in the sensing chambers 130, the color itself, the color brightness or hue (and optionally, the length of time) can be used to determine a quantitative measure of the biochemical

element or pH detected in the user's perspiration. In accordance with some embodiments, the color indicator of the sensing chamber 130 can be further calibrated by subtracting or comparing the color of the sensing chamber from the initial scan to the color from the final scan.

[0056] Other embodiments are within the scope and spirit of the invention. For example, due to the nature of software, functions described above can be implemented using software, hardware, firmware, hardwiring, or combinations of any of these. Features implementing functions may also be physically located at various positions, including being distributed such that portions of functions are implemented at different physical locations.

[0057] Further, while the description above refers to the invention, the description may include more than one invention.

What is claimed is:

1. A sensor patch comprising:
 - a perspiration volume sensing channel including at least a first colorimetric material that changes color in response to exposure to perspiration;
 - a perspiration component sensing chamber including at least a second colorimetric material that changes color in response to exposure to a biochemical component in the perspiration; and
 - a near field communication circuit and a near field communication antenna.
2. The sensor patch of claim 1, further comprising:
 - a channel inlet port in fluid communication with the perspiration volume sensing channel to allow the perspiration to enter into the perspiration volume sensing channel; and
 - a chamber inlet port in fluid communication with the perspiration component sensing chamber to allow the perspiration to enter into the perspiration component sensing chamber.
3. The sensor patch of claim 2, further comprising:
 - a channel vent port in fluid communication with the perspiration volume sensing channel to reduce backpressure as the perspiration fills the perspiration volume sensing channel; and
 - a chamber vent port in fluid communication with the perspiration component sensing chamber to reduce backpressure as the perspiration fills the perspiration component sensing chamber.
4. The sensor patch of claim 3, wherein the channel vent port vents out of a surface of the sensor patch opposite from the channel inlet port.
5. The sensor patch of claim 3, wherein the channel vent port vents to an outer edge of the sensor patch perpendicular to the channel inlet port.
6. The sensor patch of claim 1, further comprising:
 - at least one indicia configured to have a shape, a size, a color, a location, or a combination thereof for calibrating an image of the sensor patch taken by a smart device.
7. The sensor patch of claim 1, further comprising:
 - an adhesive layer configured to attach the sensor patch to a surface of a user.
8. The sensor patch of claim 7, further comprising an integrated circuit that includes the near field communication circuit.

9. A method of using a smart device and a sensor patch placed on a surface of a user to determine one or more properties of perspiration from the user, the method comprising:

- causing the smart device to interrogate a near field communication circuit of the sensor patch;
- executing a function on the smart device to obtain at least one image of the sensor patch based on data sent from the near field communication circuit in response to the interrogation; and
- analyzing the at least one image to determine a volume of the perspiration, a rate of the perspiration, one or more components within the perspiration, or a combination thereof.

10. The method of claim 9, further comprising:

- calibrating the at least one image based on one or more indicia visible on the sensor patch and captured in the at least one image.

11. The method of claim 10, wherein the calibration includes orienting and scaling the at least one image, adjusting a white balance of the at least one image based on a color of the one or more indicia, or a combination thereof.

12. The method of claim 9, wherein the analysis comprises determining a quantitative measure of one or more elements in the perspiration based on a color hue, a color value, a color intensity, or a combination thereof of a colorimetric material within a sensing chamber of the sensor patch.

13. The method of claim 9, wherein the analysis comprises determining a first length of a color change within a perspiration channel of the sensor patch, the method further comprising:

- comparing the first length of the color change with a second length of the color change within the perspiration channel of the sensor patch from analysis of at least one other image of the sensor patch; and
- determining a rate of the perspiration based on the comparison of the first length to the second length.

14. The method of claim 13, further comprising:

- determining an amount of time between acquisition of the at least one image and the at least one other image based, at least in part, on date stamps, time stamps, or a combination thereof of the at least one image and the at least one other image,

wherein the determination of the rate is based on the amount of time.

15. The method of claim 9, wherein the analysis comprises determining a first length of a color change within a perspiration channel of the sensor patch and determining a volume of perspiration based on the volume of the perspiration channel and the first length of the color change.

16. The method of claim 9, further comprising:

- determining, by the smart device, a temperature, a humidity, a pressure, a location, an elevation, or a combination thereof as metadata; and
- tagging the at least one image with the metadata for use in the analysis of the at least one image.

17. A sensor patch comprising:

- at least one perspiration sensing portion including at least one colorimetric material that changes color in response to perspiration; and
- a near field communication circuit and a near field communication antenna,

wherein the near field communication circuit is configured to cause a smart device to execute a function on the smart device based on data sent from the near field communication circuit in response to interrogation of the near field communication circuit by the smart device.

18. The sensor patch of claim **17**, wherein the at least one colorimetric material includes a plurality of colorimetric assays, each colorimetric assay of the plurality of colorimetric assays changing color in response to a different biological component within the perspiration upon exposure to the perspiration.

19. The sensor patch of claim **18**, wherein the at least one perspiration sensing portion comprises a plurality of perspiration component sensing chambers, each perspiration component sensing chamber of the plurality of perspiration component sensing chambers including a separate colorimetric assay of the plurality of colorimetric assays.

20. The sensor patch of claim **17**, wherein the at least one perspiration sensing portion comprises at least one channel formed of a plurality of channel segments, and an integrated circuit chip that includes the near field communication circuit.

* * * * *

专利名称(译)	用于测量出汗的方法和系统		
公开(公告)号	US20170296114A1	公开(公告)日	2017-10-19
申请号	US15/491379	申请日	2017-04-19
[标]申请(专利权)人(译)	MC10股份有限公司		
申请(专利权)人(译)	MC10, INC.		
当前申请(专利权)人(译)	MC10, INC.		
[标]发明人	GHAFFARI ROOZBEH HUPPERT GILBERT LEE MURPHY BRIAN KACYVENSKI ISIAH		
发明人	GHAFFARI, ROOZBEH HUPPERT, GILBERT LEE MURPHY, BRIAN KACYVENSKI, ISIAH		
IPC分类号	A61B5/00 A61B5/145		
CPC分类号	A61B5/4266 A61B5/002 A61B5/14539 A61B5/14517 A61B5/6833		
优先权	62/324723 2016-04-19 US		
外部链接	Espacenet USPTO		

摘要(译)

出汗感测系统包括传感器贴片和智能设备。传感器贴片包括一个或多个出汗感测部分。一个或多个出汗感测部分包括入口，该入口具有预定尺寸以接收来自预定数量的汗腺的汗液和用于降低背压的出口。至少一个出汗感测部分包括具有比色感测材料的通道，所述比色感测材料在暴露于出汗时改变颜色。至少一个汗液感测部分包括在基底中的比色测定，其在暴露于汗液的生化组分时改变颜色。该系统还包括具有相机的智能设备，该相机可以拍摄传感器贴片的图片并确定来自一个或多个出汗感测部分的出汗的体积，出汗率和/或生化成分。

