



US 20160287330A1

(19) **United States**

(12) **Patent Application Publication**
BRANNAN

(10) **Pub. No.: US 2016/0287330 A1**
(43) **Pub. Date: Oct. 6, 2016**

(54) **MICROWAVE FIELD-DETECTING NEEDLE ASSEMBLIES, METHODS OF MANUFACTURING SAME, METHODS OF ADJUSTING AN ABLATION FIELD RADIATING INTO TISSUE USING SAME, AND SYSTEMS INCLUDING SAME**

G01R 29/08 (2006.01)
A61B 18/14 (2006.01)
A61B 5/00 (2006.01)

(52) **U.S. Cl.**
CPC *A61B 18/1815* (2013.01); *A61B 18/1477* (2013.01); *A61B 5/4836* (2013.01); *G01R 29/0878* (2013.01); *G01R 29/0871* (2013.01); *H01Q 1/248* (2013.01); *A61B 2018/00577* (2013.01)

(71) Applicant: **COVIDIEN LP**, Mansfield, MA (US)

(72) Inventor: **JOSEPH D. BRANNAN**, LYONS, CO (US)

(21) Appl. No.: **15/177,729**

(22) Filed: **Jun. 9, 2016**

Related U.S. Application Data

(60) Continuation of application No. 14/740,331, filed on Jun. 16, 2015, now Pat. No. 9,375,279, which is a division of application No. 12/977,390, filed on Dec. 23, 2010, now Pat. No. 9,055,957.

Publication Classification

(51) **Int. Cl.**
A61B 18/18 (2006.01)
H01Q 1/24 (2006.01)

(57) **ABSTRACT**

A method of adjusting an ablation field radiating into tissue includes the initial steps of providing an energy applicator and providing one or more microwave field-detecting needle assemblies. Each microwave field-detecting needle assembly includes one or more rectifier elements capable of detecting microwave field intensity via rectification. The method includes the steps of positioning the energy applicator and the one or more microwave field-detecting needle assemblies in tissue, transmitting energy from an energy source through the energy applicator to generate an ablation field radiating about at least a portion of the energy applicator into tissue, and adjusting the ablation field radiating about at least the portion of the energy applicator into tissue based on at least one electrical signal transmitted by the one or more microwave field-detecting needle assemblies.

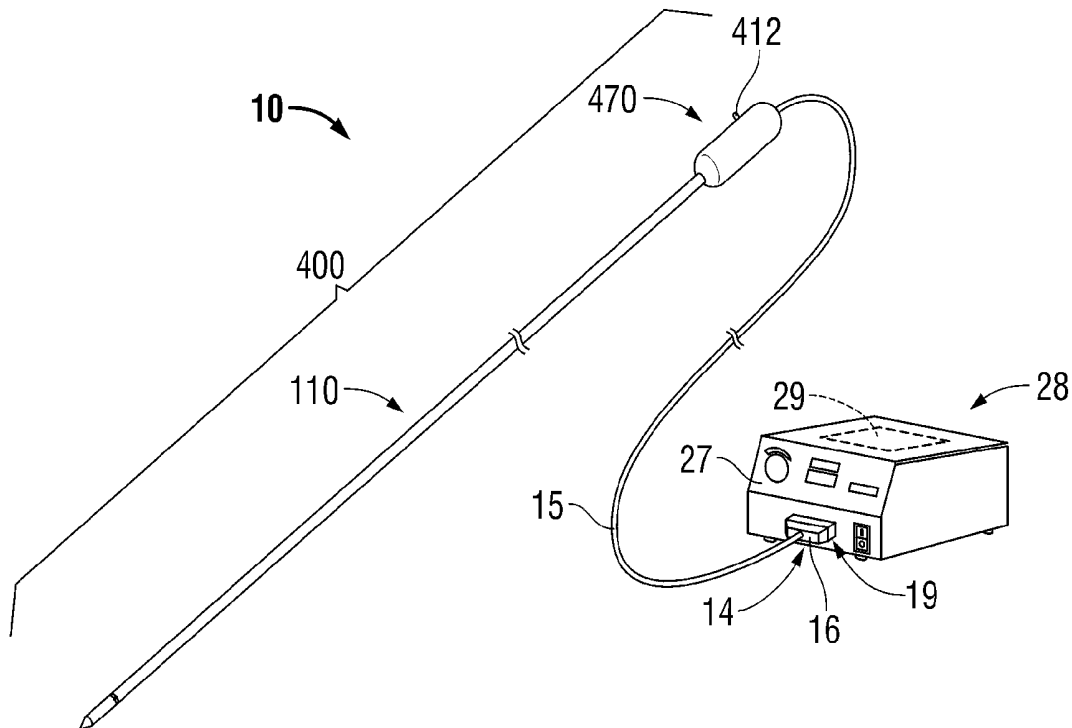

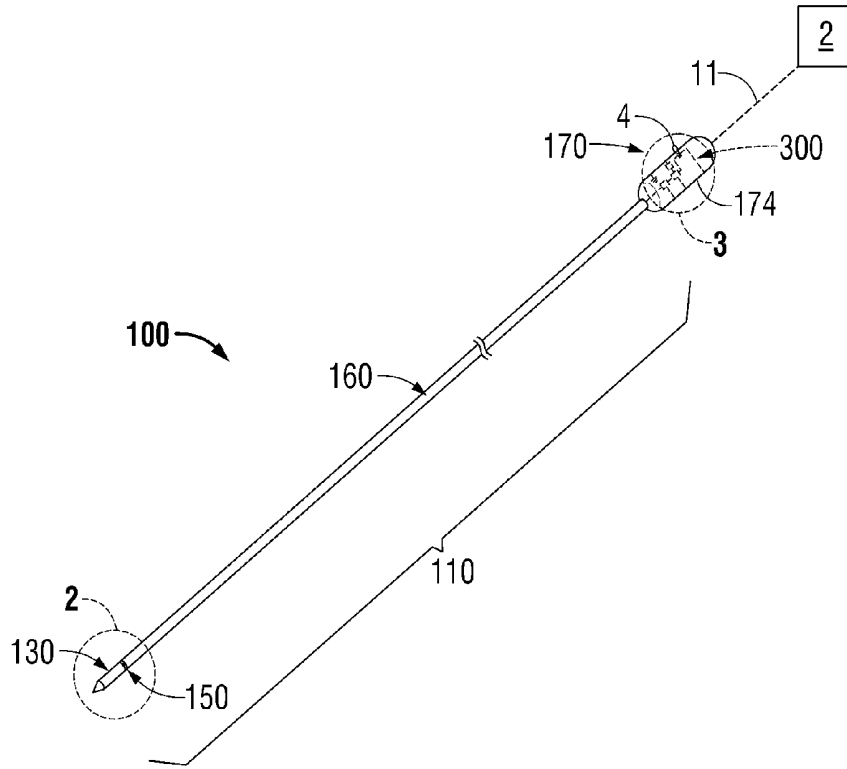

FIG. 1

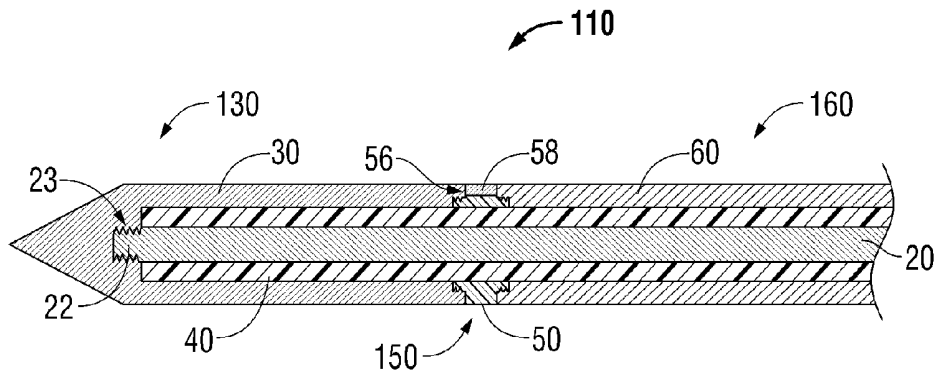

FIG. 2

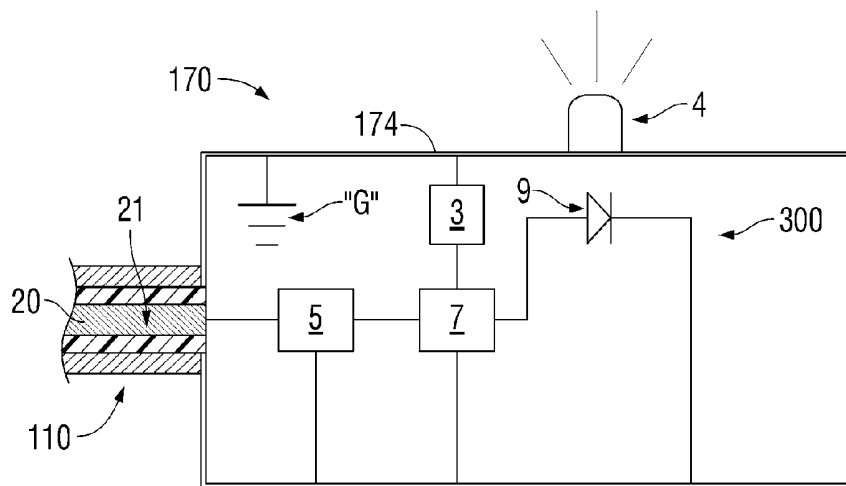

FIG. 3

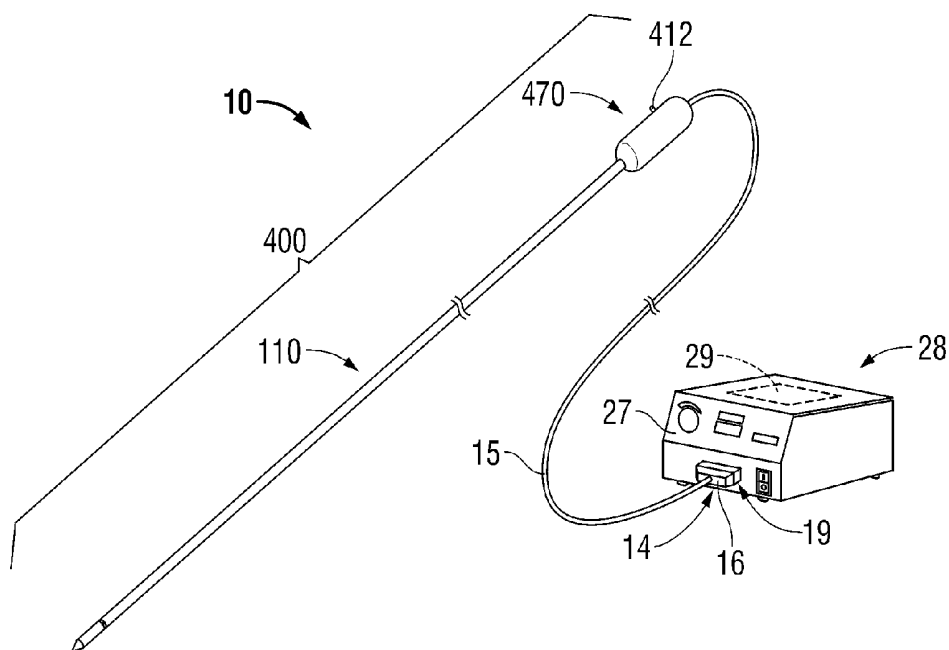

FIG. 4

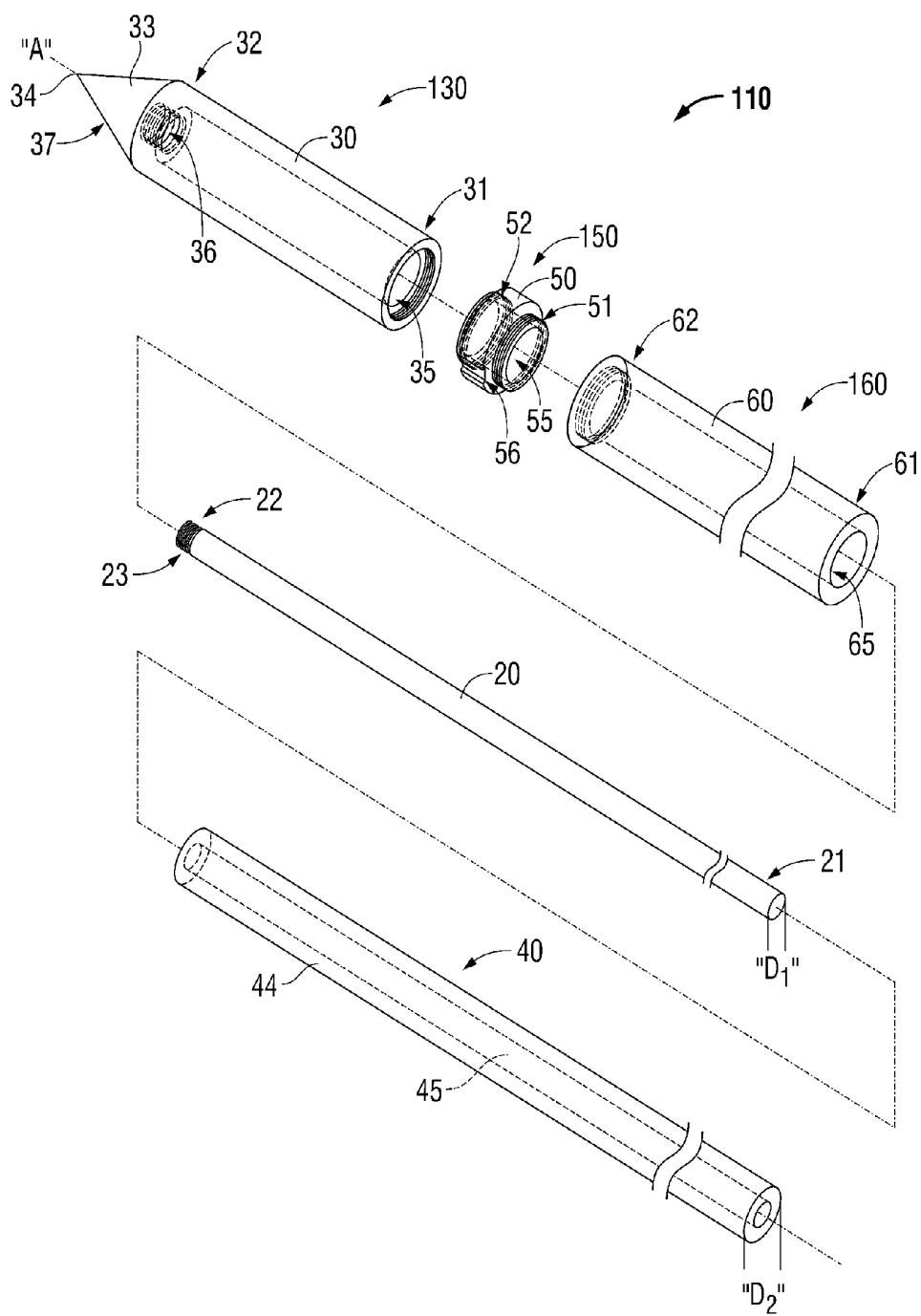

FIG. 5

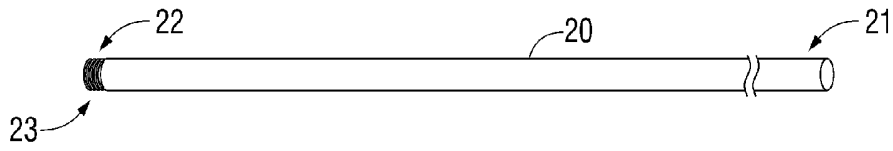

FIG. 6

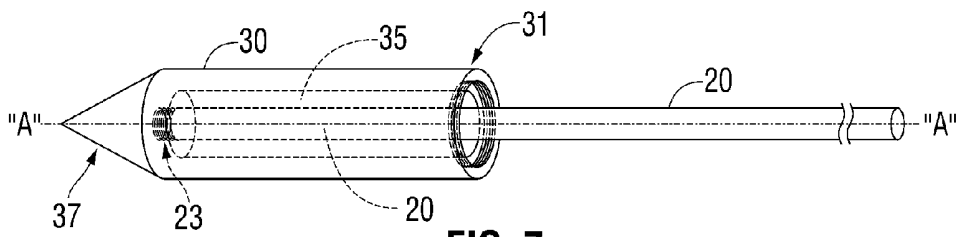

FIG. 7

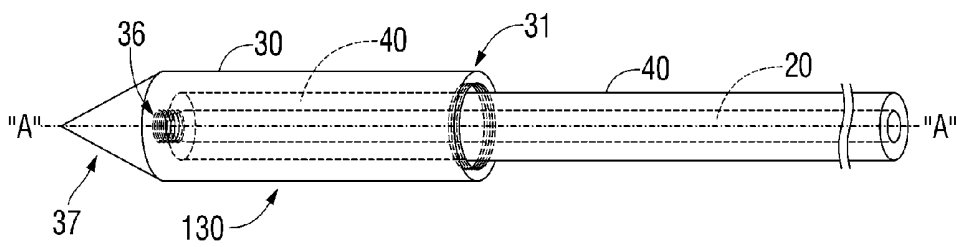

FIG. 8

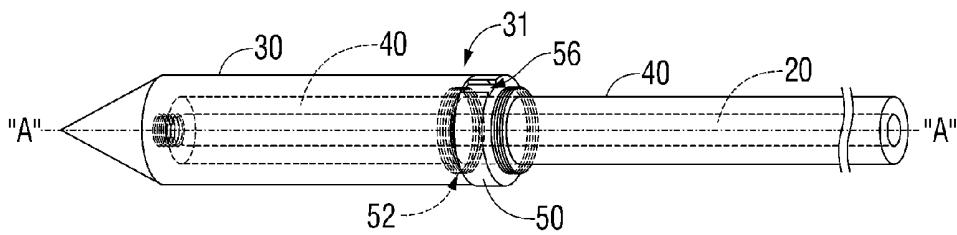

FIG. 9

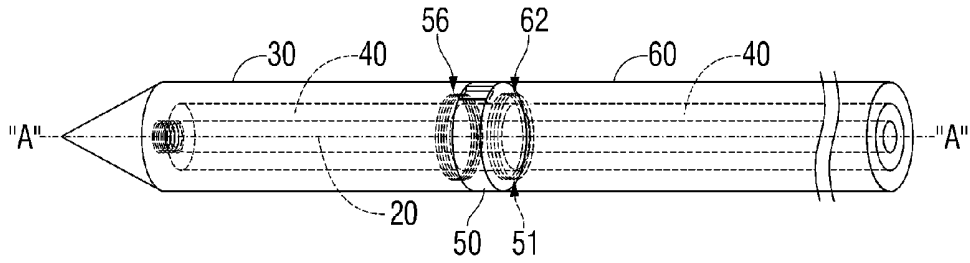

FIG. 10

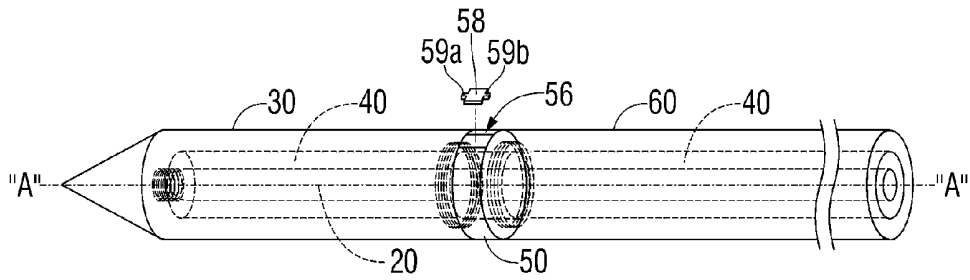

FIG. 11

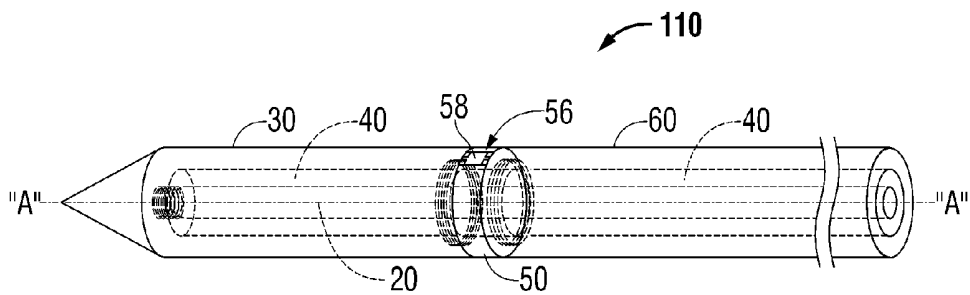

FIG. 12

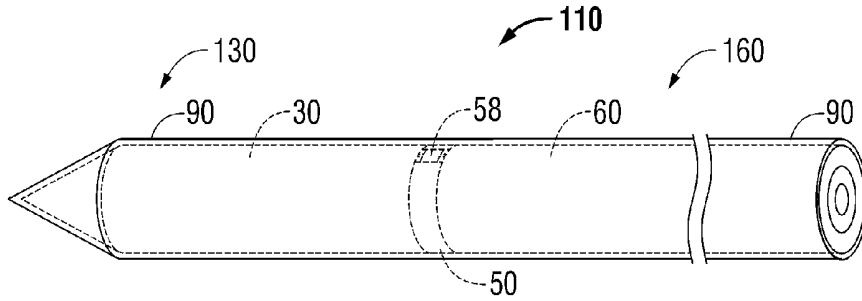

FIG. 13

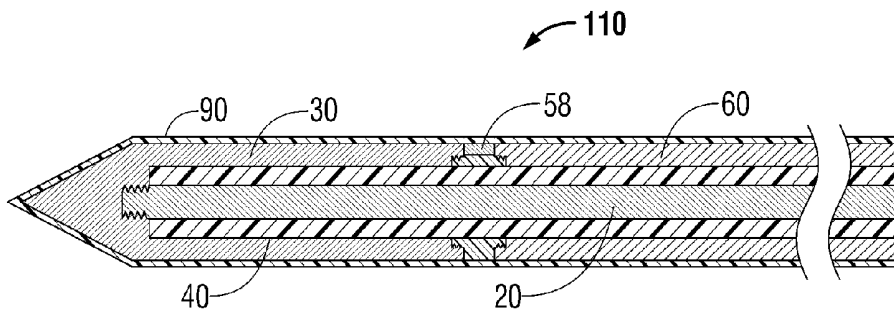

FIG. 14

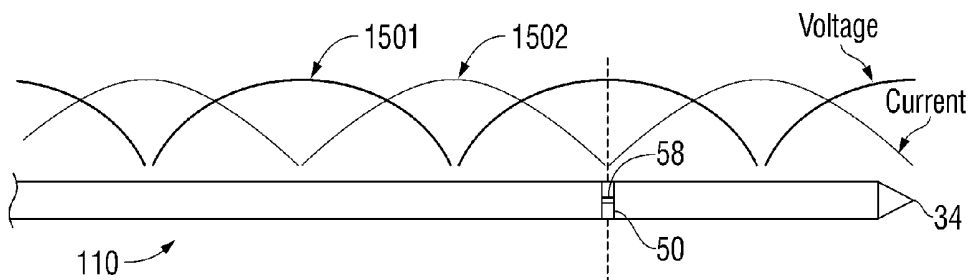

FIG. 15

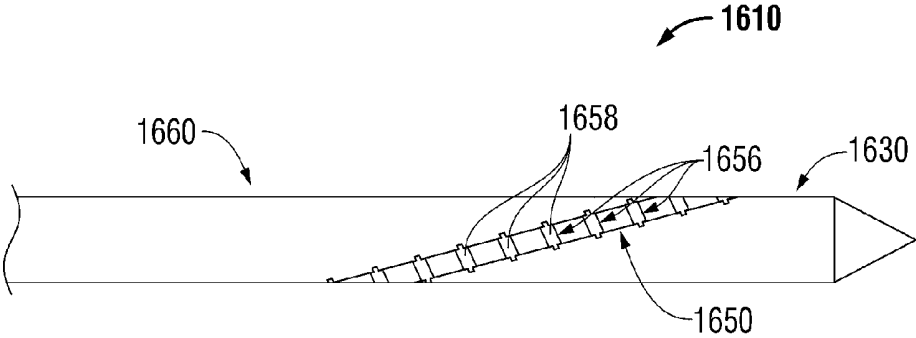

FIG. 16

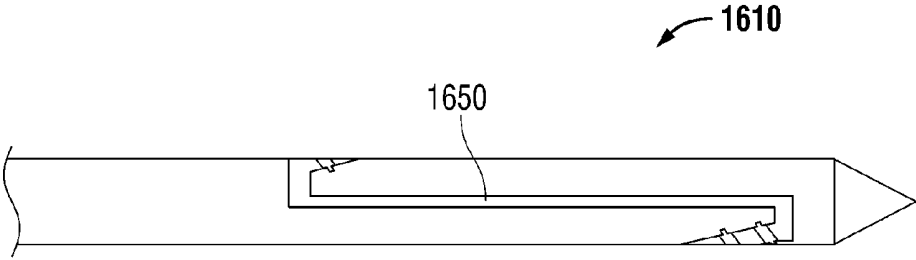

FIG. 17

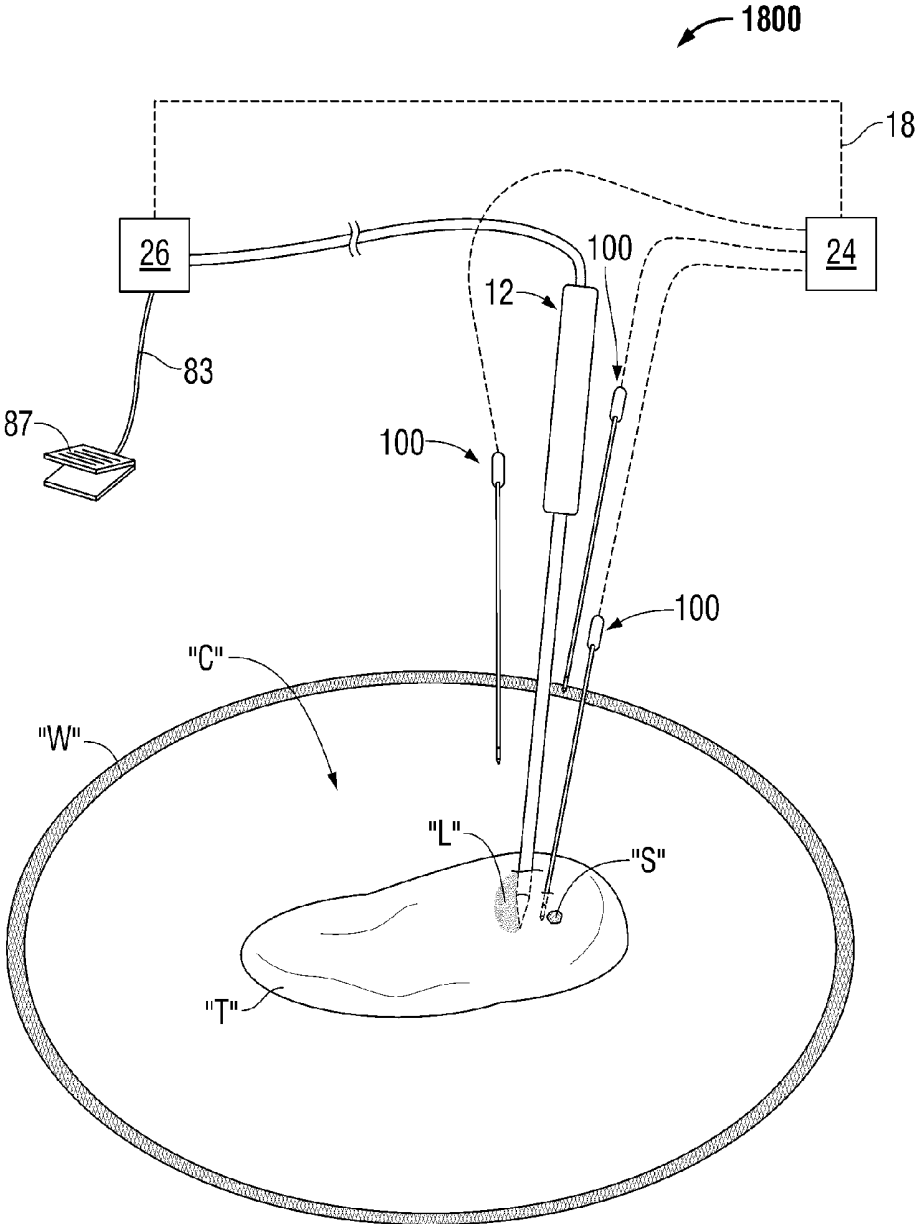

FIG. 18

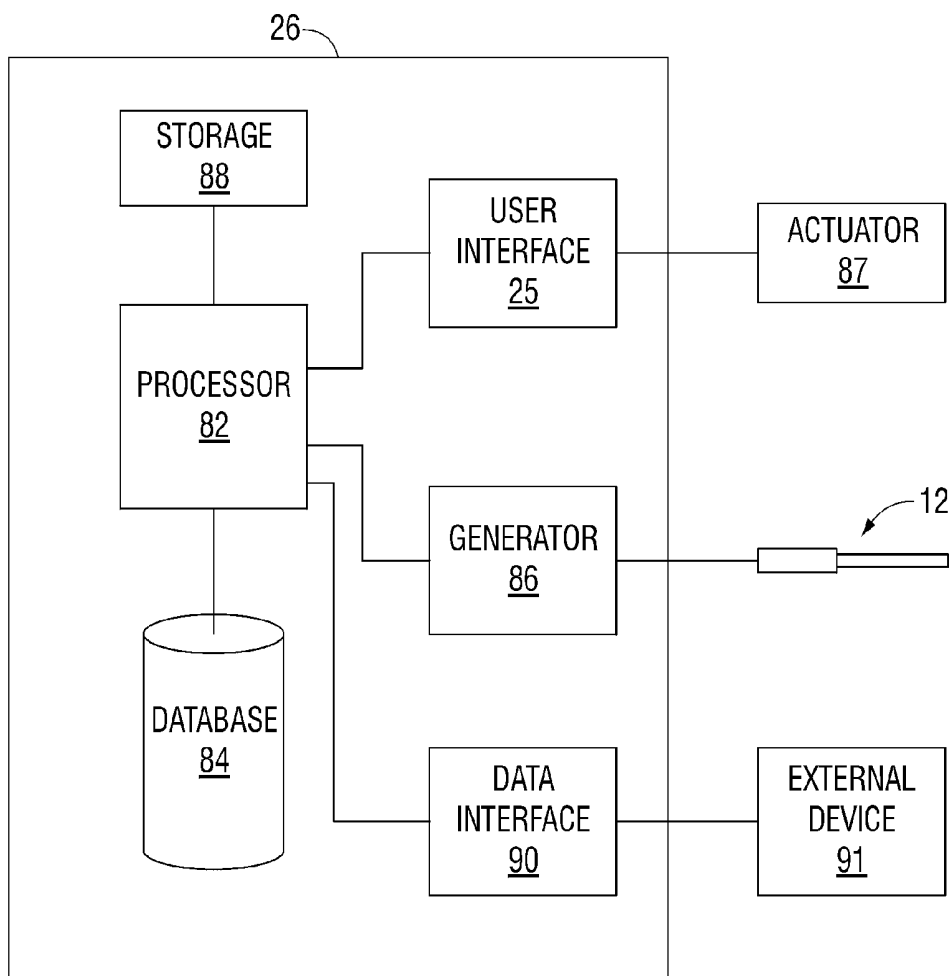

FIG. 19

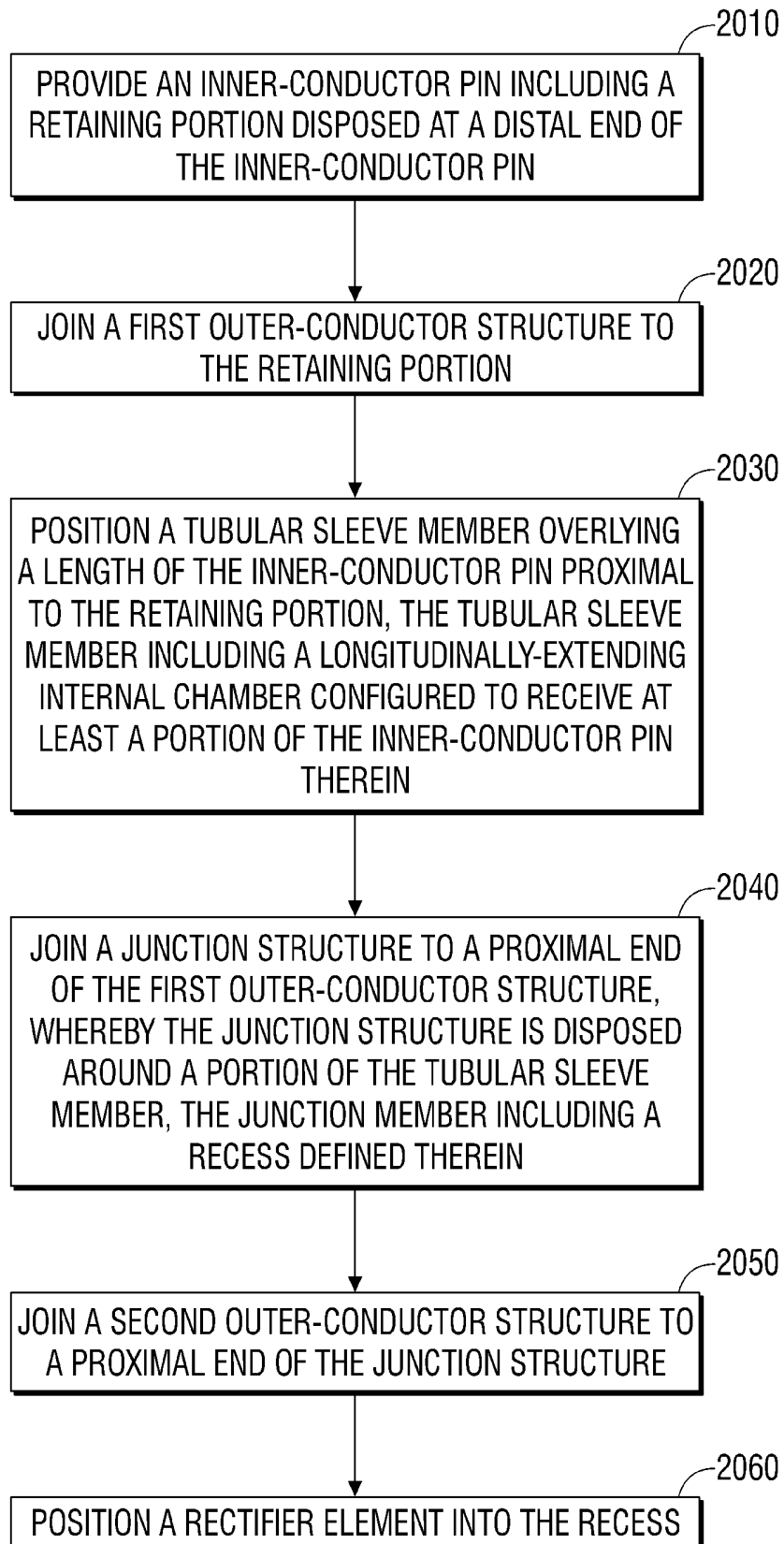

FIG. 20

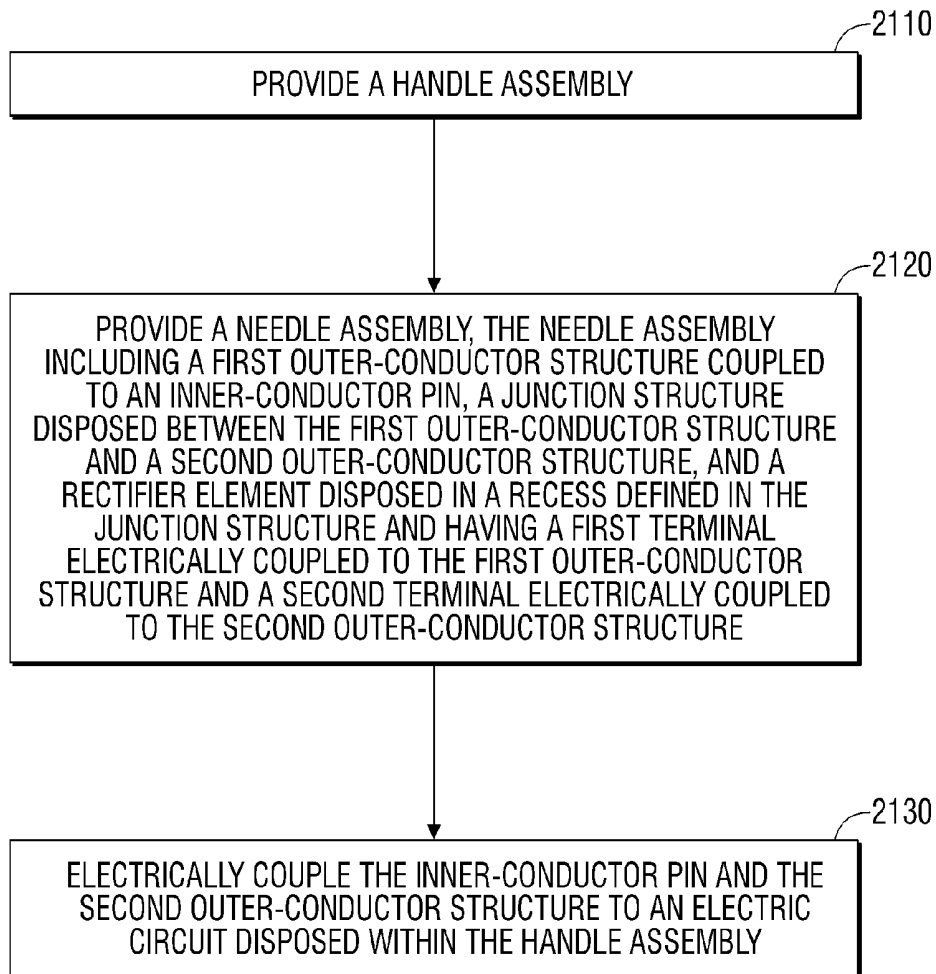

FIG. 21

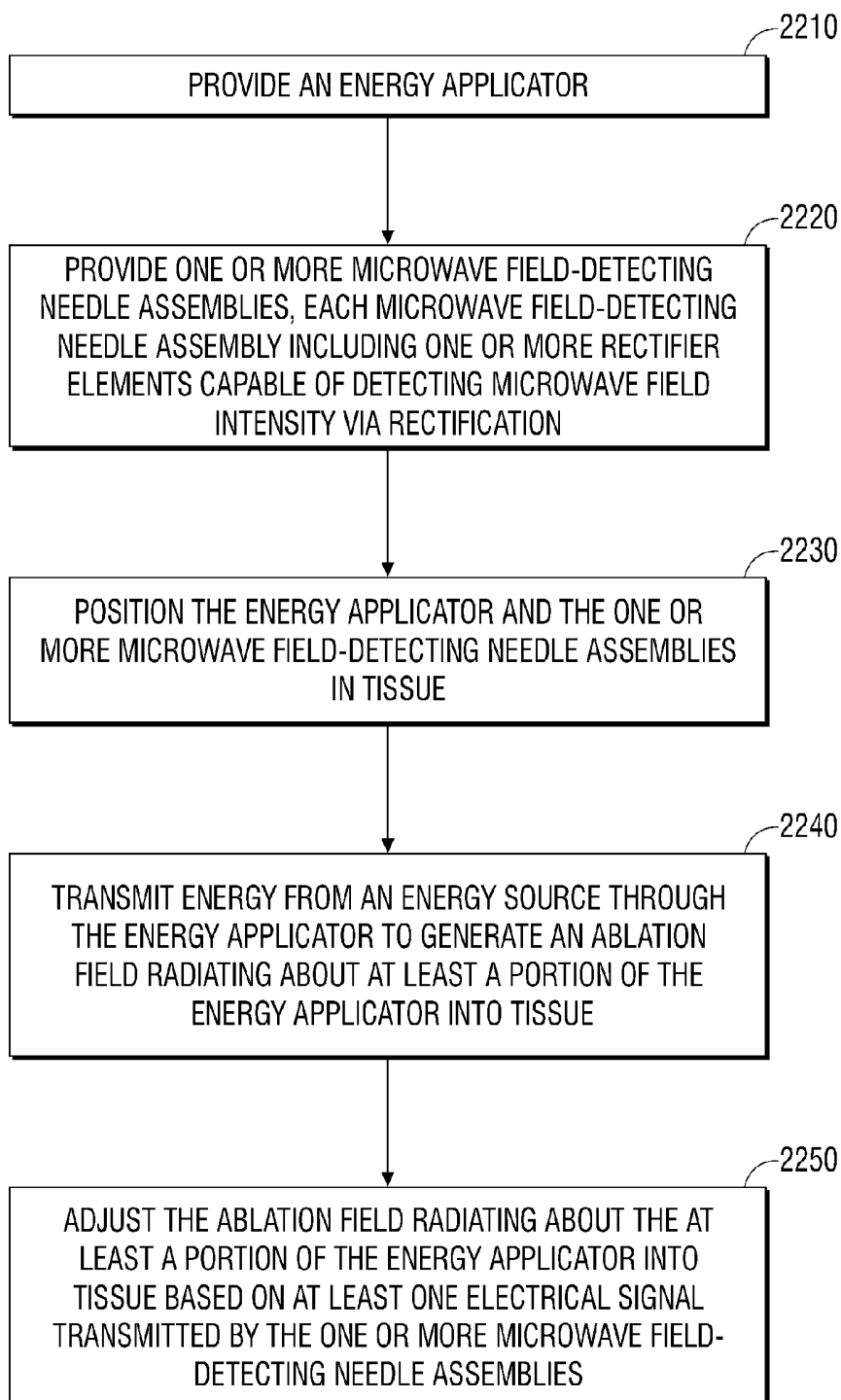

FIG. 22

**MICROWAVE FIELD-DETECTING NEEDLE
ASSEMBLIES, METHODS OF
MANUFACTURING SAME, METHODS OF
ADJUSTING AN ABLATION FIELD
RADIATING INTO TISSUE USING SAME,
AND SYSTEMS INCLUDING SAME**

**CROSS-REFERENCE TO RELATED
APPLICATIONS**

[0001] This application is a continuation application of U.S. application Ser. No. 14/740,331, filed on Jun. 16, 2015, which is a divisional application of U.S. application Ser. No. 12/977,390, filed on Dec. 23, 2010, now U.S. Pat. No. 9,055,957, the entire contents of each of which being incorporated by reference herein.

BACKGROUND

[0002] 1. Technical Field

[0003] The present disclosure relates to electrosurgical devices suitable for use in tissue ablation applications and, more particularly, to microwave field-detecting needle assemblies, methods of manufacturing the same, methods of adjusting an ablation field radiating into tissue using the same, and systems including the same.

[0004] 2. Discussion of Related Art

[0005] Treatment of certain diseases requires the destruction of malignant tissue growths, e.g., tumors. Electromagnetic radiation can be used to heat and destroy tumor cells. Treatment may involve inserting ablation probes into tissues where cancerous tumors have been identified. Once the probes are positioned, electromagnetic energy is passed through the probes into surrounding tissue.

[0006] In the treatment of diseases such as cancer, certain types of tumor cells have been found to denature at elevated temperatures that are slightly lower than temperatures normally injurious to healthy cells. Known treatment methods, such as hyperthermia therapy, heat diseased cells to temperatures above 41° C. while maintaining adjacent healthy cells below the temperature at which irreversible cell destruction occurs. These methods involve applying electromagnetic radiation to heat, ablate and/or coagulate tissue. Microwave energy is sometimes utilized to perform these methods. Other procedures utilizing electromagnetic radiation to heat tissue also include coagulation, cutting and/or ablation of tissue.

[0007] Electrosurgical devices utilizing electromagnetic radiation have been developed for a variety of uses and applications. A number of devices are available that can be used to provide high bursts of energy for short periods of time to achieve cutting and coagulative effects on various tissues. There are a number of different types of apparatus that can be used to perform ablation procedures. Typically, microwave apparatus for use in ablation procedures include a microwave generator that functions as an energy source and a microwave surgical instrument (e.g., microwave ablation probe) having an antenna assembly for directing energy to the target tissue. The microwave generator and surgical instrument are typically operatively coupled by a cable assembly having a plurality of conductors for transmitting microwave energy from the generator to the instrument, and for communicating control, feedback and identification signals between the instrument and the generator.

[0008] The particular type of tissue ablation procedure may dictate a particular ablation volume in order to achieve a desired surgical outcome. Ablation volume is correlated with antenna design, antenna performance, antenna impedance, ablation time and wattage, and tissue characteristics, e.g., tissue impedance.

[0009] Because of the small temperature difference between the temperature required for denaturing malignant cells and the temperature normally injurious to healthy cells, a known heating pattern and precise temperature control is needed to lead to more predictable temperature distribution to eradicate the tumor cells while minimizing the damage to surrounding normal tissue. In some cases, it may be difficult for the physician to determine when a microwave ablation probe is inserted to a proper depth within tissue, e.g., to reach the location of the ablation site and/or to avoid unintended radiation exposure.

SUMMARY

[0010] The present disclosure relates to method of adjusting an ablation field radiating into tissue including the initial steps of providing an energy applicator and providing one or more microwave field-detecting needle assemblies. Each microwave field-detecting needle assembly includes one or more rectifier elements capable of detecting microwave field intensity via rectification. The method includes the steps of positioning the energy applicator and the one or more microwave field-detecting needle assemblies in tissue, transmitting energy from an energy source through the energy applicator to generate an ablation field radiating about at least a portion of the energy applicator into tissue, and adjusting the ablation field radiating about at least the portion of the energy applicator into tissue based on at least one electrical signal transmitted by the one or more microwave field-detecting needle assemblies.

[0011] The present disclosure also relates to method of adjusting an ablation field radiating into tissue including the initial steps of providing an energy applicator operably coupled to an energy source and providing one or more microwave field-detecting needle assemblies. Each microwave field-detecting needle assembly includes one or more rectifier elements capable of detecting microwave field intensity via rectification. The method includes the steps of positioning the energy applicator and the one or more microwave field-detecting needle assemblies in tissue, transmitting energy from the energy source through the energy applicator to generate an ablation field radiating about at least a portion of the energy applicator into tissue, and adjusting the ablation field radiating about at least the portion of the energy applicator into tissue by adjusting at least one operating parameter associated with the energy source based on at least one electrical signal transmitted by the one or more microwave field-detecting needle assemblies.

[0012] The present disclosure also relates to a microwave ablation control system including a microwave field-detecting needle assembly and a control unit in operable communication with the microwave field-detecting needle assembly. The microwave field-detecting needle assembly includes at least one rectifier element capable of detecting microwave field intensity via rectification. The microwave ablation control system also includes an electrosurgical power generating source in operable communication with

the control unit and an energy-delivery device operably coupled to the electrosurgical power generating source.

BRIEF DESCRIPTION OF THE DRAWINGS

[0013] Objects and features of the presently-disclosed microwave field-detecting needle assemblies, methods of manufacturing the same, methods of adjusting an ablation field radiating into tissue using the same, and systems including the same will become apparent to those of ordinary skill in the art when descriptions of various embodiments thereof are read with reference to the accompanying drawings, of which:

[0014] FIG. 1 is a perspective view of microwave field-detecting needle assembly including a needle assembly and a handle assembly according to an embodiment of the present disclosure;

[0015] FIG. 2 is an enlarged, cross-sectional view of the indicated area of detail of FIG. 1 showing a distal portion of the needle assembly according to an embodiment of the present disclosure;

[0016] FIG. 3 is an enlarged view of the indicated area of detail of FIG. 1 showing a schematic diagram of an electric circuit (shown in phantom lines in FIG. 1) disposed within the handle assembly according to an embodiment of the present disclosure;

[0017] FIG. 4 is perspective view of a microwave field-detecting system including an embodiment of a microwave field-detecting needle assembly and an embodiment of a control unit in accordance with the present disclosure;

[0018] FIG. 5 is perspective view with parts separated of the microwave field-detecting needle assembly of FIG. 1 according to an embodiment of the present disclosure;

[0019] FIG. 6 is perspective view of an inner-conductor pin including a distal end configured with a retaining portion according to an embodiment of the present disclosure;

[0020] FIG. 7 is perspective view of a portion of a needle assembly including a first outer-conductor structure coupled to the retaining portion and disposed around a distal portion of the inner-conductor pin shown in FIG. 6 according to an embodiment of the present disclosure;

[0021] FIG. 8 is a perspective view of the portion of the needle assembly of FIG. 7 shown with a tubular sleeve member disposed around a length of the inner-conductor pin proximal to the threaded portion according to an embodiment of the present disclosure;

[0022] FIG. 9 is a perspective view of the portion of the needle assembly of FIG. 8 shown with a junction structure disposed around a portion of the tubular sleeve member and threadedly coupled to the proximal end of the first outer-conductor structure according to an embodiment of the present disclosure;

[0023] FIG. 10 is a perspective view of the portion of the needle assembly of FIG. 9 shown with a second outer-conductor structure disposed around a proximal portion of the tubular sleeve member and threadedly coupled to the distal end of the junction structure, according to an embodiment of the present disclosure;

[0024] FIG. 11 is a perspective view of the portion of the needle assembly of FIG. 10 shown with a rectifier element disposed separately from and positioned above a rectifier-receiving recess defined in the junction structure according to an embodiment of the present disclosure;

[0025] FIG. 12 is a perspective view of the portion of the needle assembly of FIG. 11 shown with the rectifier element

disposed in the rectifier-receiving recess according to an embodiment of the present disclosure;

[0026] FIG. 13 is a perspective view of the portion of the needle assembly of FIG. 12 shown with an outer jacket disposed around the first outer-conductor structure, second outer-conductor structure and the junction structure according to an embodiment of the present disclosure;

[0027] FIG. 14 is a cross-sectional view of the portion of the needle assembly of FIG. 13 according to an embodiment of the present disclosure;

[0028] FIG. 15 is a schematically-illustrated representation of a standing wave coupled to the needle assembly of FIG. 13 according to an embodiment of the present disclosure;

[0029] FIG. 16 is a perspective view of a first side of another embodiment of a needle assembly in accordance with the present disclosure;

[0030] FIG. 17 is a perspective view of a second side of the needle assembly of FIG. 16 according to an embodiment of the present disclosure;

[0031] FIG. 18 is a schematic perspective view of an electrosurgical system according to an embodiment of the present disclosure;

[0032] FIG. 19 is a block diagram of an embodiment of the electrosurgical power generating source of FIG. 18 in accordance with the present disclosure;

[0033] FIG. 20 is a flowchart illustrating a method of method of manufacturing a needle assembly according to an embodiment of the present disclosure;

[0034] FIG. 21 is a flowchart illustrating a method of method of manufacturing a microwave field-detecting needle assembly according to an embodiment of the present disclosure; and

[0035] FIG. 22 is a flowchart illustrating a method of adjusting an ablation field radiating into tissue.

DETAILED DESCRIPTION

[0036] Hereinafter, embodiments of microwave field-detecting needle assemblies, methods of manufacturing the same, methods of adjusting an ablation field radiating into tissue using the same, and systems including the same of the present disclosure are described with reference to the accompanying drawings. Like reference numerals may refer to similar or identical elements throughout the description of the figures. As shown in the drawings and as used in this description, and as is traditional when referring to relative positioning on an object, the term “proximal” refers to that portion of the apparatus, or component thereof, closer to the user and the term “distal” refers to that portion of the apparatus, or component thereof, farther from the user.

[0037] This description may use the phrases “in an embodiment,” “in embodiments,” “in some embodiments,” or “in other embodiments,” which may each refer to one or more of the same or different embodiments in accordance with the present disclosure. For the purposes of this description, a phrase in the form “A/B” means A or B. For the purposes of the description, a phrase in the form “A and/or B” means “(A), (B), or (A and B)”. For the purposes of this description, a phrase in the form “at least one of A, B, or C” means “(A), (B), (C), (A and B), (A and C), (B and C), or (A, B and C)”.

[0038] Electromagnetic energy is generally classified by increasing energy or decreasing wavelength into radio waves, microwaves, infrared, visible light, ultraviolet,

X-rays and gamma-rays. As it is used in this description, “microwave” generally refers to electromagnetic waves in the frequency range of 300 megahertz (MHz) (3×10^8 cycles/second) to 300 gigahertz (GHz) (3×10^{11} cycles/second). As it is used in this description, “transmission line” generally refers to any transmission medium that can be used for the propagation of signals from one point to another.

[0039] As it is used in this description, “ablation procedure” generally refers to any ablation procedure, such as, for example, microwave ablation, radiofrequency (RF) ablation, or microwave or RF ablation-assisted resection. As it is used in this description, “energy applicator” generally refers to any device that can be used to transfer energy from a power generating source, such as a microwave or RF electrosurgical generator, to tissue. For the purposes herein, the term “energy applicator” is interchangeable with the term “energy-delivery device”.

[0040] As it is used in this description, “rectifier” generally refers to circuit components that allow more electric current to flow in one direction than in the other. Rectifiers may be made of solid-state diodes, vacuum-tube diodes, mercury-arc valves, and other components. Processes that make use of rectifiers include rectification, which, simply defined, is the conversion of alternating current (AC) to direct current (DC). As it is used in this description, “diode” generally refers to electronic devices that allow electric current to flow in only one direction, while inhibiting current flow in the other. For the purposes herein, the term “diode” is interchangeable with the term “rectifier”.

[0041] As it is used in this description, “printed circuit board” (or “PCB”) generally refers to any and all systems that provide, among other things, mechanical support to electrical components, electrical connection to and between these electrical components, combinations thereof, and the like.

[0042] As it is used in this description, “length” may refer to electrical length or physical length. In general, electrical length is an expression of the length of a transmission medium in terms of the wavelength of a signal propagating within the medium. Electrical length is normally expressed in terms of wavelength, radians or degrees. For example, electrical length may be expressed as a multiple or sub-multiple of the wavelength of an electromagnetic wave or electrical signal propagating within a transmission medium. The wavelength may be expressed in radians or in artificial units of angular measure, such as degrees. The electric length of a transmission medium may be expressed as its physical length multiplied by the ratio of (a) the propagation time of an electrical or electromagnetic signal through the medium to (b) the propagation time of an electromagnetic wave in free space over a distance equal to the physical length of the medium. The electrical length is in general different from the physical length. By the addition of an appropriate reactive element (capacitive or inductive), the electrical length may be made significantly shorter or longer than the physical length.

[0043] Various embodiments of the present disclosure provide microwave field-detecting needle assemblies adapted to enable physicians to detect microwave field intensity in proximity to an energy-delivery devices, e.g., to ensure patient and/or physician safety and/or to provide for improved control over applied energy. Microwave field-detecting needle assembly embodiments may be implemented as passive devices. In some embodiments, micro-

wave field-detecting needle assemblies may be monitored by a stand-alone control unit. Microwave field-detecting needle assembly embodiments may be integrated into a feedback control loop within a microwave ablation control system.

[0044] Microwave field-detecting needle assembly embodiments may be suitable for utilization in open surgical applications. Embodiments may be used in minimally invasive procedures, e.g., endoscopic and laparoscopic surgical procedures. Portions of the presently-disclosed microwave field-detecting needle assemblies may be disposable, replaceable and/or reusable.

[0045] Various embodiments of the presently-disclosed microwave field-detecting needle assembly are adapted to be coupled in communication with a stand-alone control unit (e.g., 28 shown in FIG. 4).

[0046] An electrosurgical system (also referred to herein as a “microwave ablation control system”) including an energy-delivery device(s) and one or more microwave field-detecting needle assemblies according to various embodiments is designed and configured to operate at frequencies between about 300 MHz and about 10 GHz. The presently-disclosed microwave ablation control systems are suitable for microwave or RF ablation and for use to pre-coagulate tissue for microwave or RF ablation-assisted surgical resection. In addition, although the following description describes embodiments of a microwave field-detecting needle assembly capable of detecting electromagnetic radiation at microwave frequencies, the teachings of the present disclosure may also apply to electromagnetic radiation at RF frequencies or at other frequencies.

[0047] FIGS. 1 through 3 show an embodiment of a microwave field-detecting needle assembly (shown generally as 100 in FIG. 1). Microwave field-detecting needle assembly 100 generally includes a handle assembly 170 and a needle assembly 110. FIG. 3 shows a schematic diagram of an electric circuit 300 (shown in phantom lines in FIG. 1) disposed within a handle housing 174 of the handle assembly 170. Needle assembly 110 is shown with parts separated in FIG. 5.

[0048] As shown in FIGS. 1, 2 and 5, the needle assembly 110 generally includes a distal portion 130, a proximal portion 160, and a junction member 150 disposed between the distal portion 130 and the proximal portion 160. In some embodiments, the distal portion 130 and the proximal portion 160 align at the junction member 150, which is generally made of a dielectric material. In some embodiments, the junction member 150 may be configured to be mechanically coupleable (e.g., threadedly coupleable) to the distal portion 130 and/or the proximal portion 160. In some embodiments, the distal portion 130 includes a first outer-conductor structure 30, the proximal portion 160 includes a second outer-conductor structure 60, and the junction member 150 includes a junction structure 50. The shape and size of the needle assembly 110 and the handle assembly 170 may be varied from the configuration depicted in FIG. 1.

[0049] As shown in FIGS. 2 and 5, needle assembly 110 includes an inner-conductor pin 20, a tubular sleeve member 40 disposed around at least a portion of the inner-conductor pin 20, a first outer-conductor structure 30, a second outer-conductor structure 60, a junction structure 50 disposed between the first outer-conductor structure 30 and the second outer-conductor structure 60, and one or more rectifiers 58 disposed in one or more recesses 56 defined in the junction structure 50. Inner-conductor pin 20 has a suitable

outer diameter “ D_1 ” (FIG. 5). The distal end 22 of the inner-conductor pin 20 includes a retaining portion 23. In some embodiments, the retaining portion 23 may be externally threaded. In one embodiment, the proximal end 21 of the inner-conductor pin 20 is coupled to the handle assembly 170. Inner-conductor pin 20 may be electrically coupled to an electric circuit 300, which is described in more detail later in this disclosure, disposed within the handle assembly 170.

[0050] Various components of the needle assembly 110 may be formed of suitable, electrically-conductive materials, e.g., copper, gold, silver, or other conductive metals or metal alloys having similar conductivity values. Electrically-conductive materials used to form the inner-conductor pin 20, the first outer-conductor structure 30 and/or the second outer-conductor structure 60 may be plated with other materials, e.g., other conductive materials, such as gold or silver, to improve their properties, e.g., to improve conductivity, decrease energy loss, etc.

[0051] In some embodiments, the inner-conductor pin 20, the first outer-conductor structure 30 and/or the second outer-conductor structure 60 may be formed of a rigid, electrically-conductive material, such as stainless steel. In some embodiments, the inner-conductor pin 20 is formed from a first electrically-conductive material (e.g., stainless steel) and the first outer-conductor structure 30 and/or the second outer-conductor structure 60 is formed from a second electrically-conductive material (e.g., copper). In some embodiments, the inner-conductor pin 20, the first outer-conductor structure 30 and/or the second outer-conductor structure 60 may be formed of a flexible, electrically-conductive material, such as titanium.

[0052] Tubular sleeve member 40 includes a body 44 that defines a longitudinally-extending internal bore or chamber 45 configured to receive at least a portion of the inner-conductor pin 20 therein. Body 44 has a suitable outer diameter “ D_2 ” as shown in FIG. 5. Tubular sleeve member 40 may be formed from any suitable dielectric material, including, but not limited to, ceramics, mica, polyethylene, polyethylene terephthalate, polyimide, polytetrafluoroethylene (PTFE) (e.g., TEFLON®, manufactured by E. I. du Pont de Nemours and Company of Wilmington, Del., United States), glass, metal oxides or other suitable insulator, and may be formed in any suitable manner. In the embodiment shown in FIG. 2, tubular sleeve member 40 is disposed around a length of the inner-conductor pin 20 proximal to the retaining portion 23.

[0053] Junction member embodiments in accordance with the present disclosure include a junction structure having one or more recesses (e.g., one recess 56 shown in FIGS. 2, 5 and 9-12, or a plurality of recesses 1656 shown in FIG. 16) defined therein. As best shown in FIG. 11, the recess 56 is configured to receive a rectifier 58 therein. Rectifier 58 may include one or more diodes, e.g., Zener diode, Schottky diode, tunnel diode and the like, and/or other suitable component(s) capable of converting AC to DC.

[0054] Junction structure 50 may be formed of any suitable elastomeric or ceramic dielectric material by any suitable process. In some embodiments, the junction structure 50 may be formed of a composite material having low electrical conductivity, e.g., glass-reinforced polymers. In some embodiments, the junction structure 50 is formed by over-molding and includes a thermoplastic elastomer, such as, for example, polyether block amide (e.g., PEBAX®, manufactured by The Arkema Group of Colombes, France),

polyetherimide (e.g., ULTEM® and/or EXTEM®, manufactured by SABIC Innovative Plastics of Saudi Arabia) and/or polyimide-based polymer (e.g., VESPEL®, manufactured by E. I. du Pont de Nemours and Company of Wilmington, Del., United States). Junction structure 50 may be formed using any suitable over-molding compound by any suitable process, and may include use of a ceramic substrate.

[0055] In an embodiment, as best shown in FIG. 3, electric circuit 300 is disposed within the handle housing 174 of the handle assembly 170. In one embodiment, electric circuit 300 may be formed as a printed circuit board, with components thereof connected by traces on an epoxy resin substrate.

[0056] Handle housing 174 provides a ground reference “G” for the circuit 300. An indicator unit 4, or component thereof, is coupled to the handle housing 174. Indicator unit 4 may include audio and/or visual indicator devices to provide information/feedback to a user. In the embodiment shown in FIGS. 1 and 3, the indicator unit 4 is adapted to generate a visual signal and includes a light source, such as a light-emitting diode 9. Indicator unit 4 may additionally, or alternatively, be adapted to generate an audio signal and may include an audio circuit with a speaker (not shown).

[0057] The proximal end 21 of the inner-conductor pin 20 (shown in cross section in FIG. 3) is electrically coupled to a first terminal of a filter circuit 5. Filter circuit 5 includes a second terminal electrically coupled to an amplifier circuit 7, and may include a ground terminal electrically coupled to the handle housing 174. Filter circuit 5 may include an RF filter block. In one embodiment, the filter circuit 5 may be an inductor-resistor-capacitor (LCR) low-pass filter that is adapted to convert a rectified sinusoidal waveform from the rectifier element(s) 58 into an electrical signal, which may be a DC voltage signal representative of the detected microwave field intensity.

[0058] As shown in FIG. 3, circuit 300 includes a power source 3 that is electrically coupled to the amplifier circuit 7. Power source 3 may include a ground terminal electrically coupled to the handle housing 174. Power source 3 may include any combination of battery cells, a battery pack, fuel cell and/or high-energy capacitor. A battery pack may include one or more disposable batteries. In such case, the one or more disposable batteries may be used as a primary power source for the amplifier circuit 7. In some embodiments, a transmission line 11 (FIG. 1) is provided to connect the microwave field-detecting needle assembly to a line source voltage or external power source (shown generally as 2 in FIG. 1), in which case a battery pack may be provided for use as a backup power source.

[0059] FIG. 4 schematically illustrates an embodiment of a microwave field-detecting system (shown generally as 10) that includes a stand-alone control unit 28 operably coupled to a microwave field-detecting needle assembly 400. Microwave field-detecting needle assembly 400 is similar to the microwave field-detecting needle assembly 100 of FIG. 1, except that microwave field-detecting needle assembly 400 includes a handle assembly 470 configured to operably couple the needle assembly 110 to a cable assembly 15. Cable assembly 15 may be any suitable transmission line. Cable assembly 15 may include a proximal end 14 suitable for connection to the control unit 28.

[0060] Handle assembly 470 includes an indicator unit 412 that is suitably configured to provide information/

feedback to a user. Indicator unit 412 is similar to the indicator unit 4 shown in FIG. 3 and further description thereof is omitted in the interests of brevity. The shape and size of the handle assembly 470 and the indicator unit 412 may be varied from the configuration depicted in FIG. 4.

[0061] Control unit 28 may include a user interface 27 in operable communication with a processor unit 29. User interface 27 may include audio and/or visual indicator devices to provide information/feedback to a user. Processor unit 29 may be any type of computing device, computational circuit, or any type of processor or processing circuit capable of executing a series of instructions that are stored in a memory (not shown) associated with the processor unit 29. Processor unit 29 may be adapted to run an operating system platform and application programs. Microwave field-detecting needle assembly 400 and the control unit 28 may utilize wired communication and/or wireless communication. In the embodiment illustrated in FIG. 4, the microwave field-detecting needle assembly 400 is electrically connected via the cable assembly 15 to a connector 16, which further operably connects the microwave field-detecting needle assembly 400 to a terminal 19 of the control unit 28.

[0062] FIG. 5 shows the needle assembly 110 with parts separated in accordance with the present disclosure. As described above with reference to FIG. 2, the needle assembly 110 includes an inner-conductor pin 20, first outer-conductor structure 30, second outer-conductor structure 60, tubular sleeve member 40, junction structure 50, and one or more rectifiers 58.

[0063] As shown in FIG. 5, the first outer-conductor structure 30 defines a first chamber portion 36 and a second chamber portion 35. First chamber portion 36 is disposed at the distal end 32 of the first outer-conductor structure 30. Second chamber portion 35 is disposed in communication with the first chamber portion 36 and includes an opening disposed at the proximal end 31 of the first outer-conductor structure 30. In some embodiments, the first chamber portion 36 is configured to matingly engage, e.g., threadedly engage, with the retaining portion 23 of inner-conductor pin 20, and the second chamber portion 35 is configured to receive at least a portion of the tubular sleeve member 40 therein.

[0064] First outer-conductor structure 30 may be provided with an end cap 37. End cap 37 generally includes a tapered portion 33, which may terminate in a sharp tip 34 to allow for insertion into tissue with minimal resistance. Tapered portion 33 may include other shapes, such as, for example, a tip 34 that is rounded, flat, square, hexagonal, or cylindrical. End cap 37 may be formed of a material having a high dielectric constant, and may be a trocar, e.g., a zirconia ceramic. First outer-conductor structure 30 and end cap 37 may be formed separately from each other, and coupled together, e.g., with the aid of adhesive or solder. First outer-conductor structure 30 and end cap 37 may form a single, unitary structure. The shape and size of the first outer-conductor structure 30 and the end cap 37 may be varied from the configuration depicted in FIG. 5.

[0065] Second outer-conductor structure 60 defines a longitudinally-extending internal bore or chamber 65 that extends from the proximal end 61 to the distal end 62 of the second outer-conductor structure 60. Chamber 65 is configured to receive at least a portion of the tubular sleeve member 40 therein.

[0066] Junction structure 50 defines a longitudinally-extending internal bore or chamber 55 therein and generally includes a distal end 52 adapted for connection to the first outer-conductor structure 30 and a proximal end 51 adapted for connection to the second outer-conductor structure 60. In some embodiments, the junction structure 50 includes a distal end 52 provided with a series of external threads configured to matingly engage with a series of internal threads disposed at the proximal end 31 of the first outer-conductor structure 30, and a proximal end 51 provided with a series of external threads configured to matingly engage with a series of internal threads disposed at the distal end 62 of the second outer-conductor structure 60. The shape and size of the junction structure 50 may be varied from the configuration depicted in FIG. 5.

[0067] FIGS. 6 through 13 show a sequentially-illustrated, assembly of components forming the needle assembly 110 in accordance with the present disclosure. FIG. 6 shows the inner-conductor pin 20. As described above, inner-conductor pin 20 may be formed of any suitable electrically-conductive material (e.g., metal such as stainless steel, aluminum, titanium, copper, etc.) of any suitable length. The shape and size of the inner-conductor pin 20 may be varied from the configuration depicted in FIG. 6.

[0068] As cooperatively shown in FIGS. 6 and 7, inner-conductor pin 20 includes a distal end 22 including a retaining portion 23 that is configured to be connectable, e.g., electrically and mechanically, to the first outer-conductor structure 30. In some embodiments, the retaining portion 23 is provided with a series of external threads configured to matingly engage with a series of internal threads disposed within the first chamber portion 36 of the first outer-conductor structure 30. Alternatively, mechanical fasteners, grooves, flanges, adhesives, and welding processes, e.g., laser welding, or other suitable joining method may be used to attach (or clip, connect, couple, fasten, secure, etc.) the inner-conductor pin 20 to the first outer-conductor structure 30. As shown in FIG. 7, a longitudinal axis "A"-A" is defined by the inner-conductor pin 20.

[0069] As cooperatively shown in FIGS. 8 through 10, tubular sleeve member 40 is configured to be receivable within second chamber portion 35 of the first outer-conductor structure 30, chamber 55 of the junction structure 50 and chamber 60 of the second outer-conductor structure 60. FIG. 8 shows the tubular sleeve member 40 joined together with the inner-conductor pin 20 and the first outer-conductor structure 30 such that the tubular sleeve member 40 is coaxially-disposed about the length of the inner conductor 20 proximal to the retaining portion 23 and disposed at least in part within the second chamber portion 35 of the first outer-conductor structure 30. In an embodiment, the tubular sleeve member 40 is positioned around the inner-conductor pin 20 after the retaining portion 23 is coupled to the end cap 37, e.g., as shown in FIG. 8. Tubular sleeve member 40 may, alternatively, be positioned, formed, adhered or otherwise disposed around at least a portion of the inner-conductor pin 20 prior to the introduction of the inner-conductor pin 20 into the second chamber portion 35 of the first outer-conductor structure 30.

[0070] FIG. 9 shows the portion of the needle assembly of FIG. 8 shown with junction structure 50 disposed around a portion of the tubular sleeve member 40 and coupled to the first outer-conductor structure 30. Junction structure 50 may be coupled to the first outer-conductor structure 30 by any

suitable manner of connection. In the embodiment shown in FIG. 9, junction structure 50 includes a distal end 52 provided with a series of external threads configured to matingly engage with a series of internal threads disposed at the proximal end 31 of the first outer-conductor structure 30. The junction structure 50 and the first outer-conductor structure 30 (as well as other components described herein) may be assembled together with the aid of alignment pins, snap-like interfaces, tongue and groove interfaces, locking tabs, adhesive ports, etc., utilized either alone or in combination for assembly purposes.

[0071] FIG. 10 shows the portion of the needle assembly of FIG. 9 shown with second outer-conductor structure 60 disposed around a portion of the tubular sleeve member 40 and coupled to the proximal end 51 of the junction structure 50. In the embodiment shown in FIG. 10, second outer-conductor structure 60 includes a distal end 62 provided with a series of internal threads configured to matingly engage with a series of external threads disposed at the proximal end 51 of the junction structure 50.

[0072] FIG. 11 shows the portion of the needle assembly of FIG. 10 shown with rectifier element 58 disposed above rectifier-receiving recess 56 in the junction structure 50. Rectifier element 58 includes a first lead wire or pin 59a (also referred to herein as a "terminal") and a second lead wire or pin 59b. Rectifier-receiving recess 56 may be configured to receive the rectifier element 58 such that the first pin 59a and the second pin 59b are substantially aligned with the longitudinal axis "A"-A defined by the inner-conductor pin 20.

[0073] FIG. 12 shows the portion of the needle assembly of FIG. 11 shown with the rectifier element 58 disposed in the rectifier-receiving recess 56. First pin 59a is electrically coupled to the first outer-conductor structure 30 by any suitable manner of electrical connection, e.g., soldering, welding, or laser welding. Second pin 59b is electrically coupled to the second outer-conductor 60 by any suitable manner of electrical connection.

[0074] FIG. 13 shows the portion of the needle assembly of FIG. 12 shown with an outer jacket 90 disposed around the first outer-conductor structure 30, the second outer-conductor structure 60, and the junction structure 50. Outer jacket 90 may be formed of any suitable material, such as, for example, polymeric or ceramic materials. The outer jacket 90 may be applied by any suitable method, such as, for example, heat-shrinkage, extrusion, molding, coating, spraying, dipping, powder coating, baking and/or film deposition, or other suitable process.

[0075] In an embodiment, as best shown in FIG. 14, which shows the cross section of the needle assembly portion of FIG. 13, outer jacket 90 covers the rectifier element 58. In alternative embodiments, the outer jacket 90 may include an opening (not shown) configured to expose the rectifier element 58 and/or the junction structure 50, or portion thereof.

[0076] The position of the junction structure 50 and rectifier element 58, e.g., in relation to the tip 34, is one factor in determining the operational frequency of the microwave field-detecting needle assembly 100 in a given material, e.g., tissue. To obtain a microwave field-detecting needle assembly having a desired frequency, the junction structure 50 may be positioned at a location of high voltage along the expected standing wave that couples onto the probe, such as illustratively shown in FIG. 15. During a procedure, e.g., an

ablation procedure, fields 1501, 1502 couple onto the microwave field-detecting needle assembly 100 from the energy supplied by an energy-delivery device (e.g., 12 shown in FIG. 18), e.g., a microwave ablation probe.

[0077] FIGS. 16 and 17 show a needle assembly (shown generally as 1610) according to an embodiment of the present disclosure that is adapted to enable multi-frequency operation and/or multiple wavelength operation. Needle assembly 1610 is similar to the needle assembly 110 shown in FIGS. 1, 2 and 5, except for the configuration of the junction structure 1650, the first outer-conductor structure 1630 and the second outer-conductor structure 1660, and the plurality of rectifiers 1658 disposed in the plurality of recesses 1656.

[0078] Needle assembly 1610 includes a junction structure 1650 configured to separate a first outer-conductor structure 1630 and a second outer-conductor structure 1660 in a diagonal fashion. First outer-conductor structure 1630 and the second outer-conductor structure 1660 may be formed of any suitable electrically-conductive material, e.g., metal such as stainless steel, aluminum, titanium, copper, or the like. In some embodiments, the first outer-conductor structure 1630 is constructed from stainless steel, and may be coated in a high electrical conductivity, corrosion-resistant metal, e.g., silver, or the like.

[0079] As best shown in FIG. 16, the junction structure 1650 includes a plurality of recesses 1656 defined therein, wherein each recess 1656 is defined in a different outer-peripheral portion of the junction structure 1650 and configured to receive a rectifier 1658 therein. Rectifier 1658 is similar to the rectifier 58 shown in FIG. 2 and further description thereof is omitted in the interests of brevity. Each rectifier 1658 may be configured to operate efficiently at separate frequencies allowing for probe use at multiple frequencies.

[0080] FIG. 18 shows an electrosurgical system 1800 according to an embodiment of the present disclosure that includes an energy applicator or probe 12 operably coupled to an electrosurgical power generating source 26. In some embodiments, the probe 12 may be coupled in fluid communication with a coolant supply system (not shown).

[0081] Electrosurgical system 1800 (also referred to herein as a "microwave ablation control system") generally includes one or more microwave field-detecting needle assemblies 100 and a control unit 24 in operable communication with the one or more microwave field-detecting needle assemblies 100. Control unit 24 and the one or more microwave field-detecting needle assemblies 100 may utilize wired communication and/or wireless communication. Control unit 24 is similar to the control unit 28 shown in FIG. 4 and further description thereof is omitted in the interests of brevity. Electrosurgical system 1800 according to various embodiments may include a feedback loop 18 suitable for use in controlling an energy applicator or probe 12 based on one or more electrical signals transmitted by one or more microwave field-detecting needle assemblies 100. Feedback loop 18 may utilize a cable connection and/or a wireless connection, e.g., a radiofrequency or infrared link.

[0082] In some embodiments, the microwave ablation control system 1800 may adjust the ablation field radiating about at least a portion of the energy applicator 12 into tissue by adjusting one or more operating parameters associated with the electrosurgical power generating source 26 based on one or more electrical signals transmitted by one or more

microwave field-detecting needle assemblies **100**. In the embodiment illustrated in FIG. **18**, the plurality of microwave field-detecting needle assemblies **100** in operable communication with the control unit **24** are operable coupled via the feedback loop **18** to the electrosurgical power generating source **26**. Examples of operating parameters associated with the electrosurgical power generating source **26** include temperature, impedance, power, current, voltage, mode of operation, and duration of application of electromagnetic energy.

[0083] It is to be understood that, although one energy applicator **12** and three microwave field-detecting needle assemblies **100** are shown in FIG. **18**, electrosurgical system embodiments may utilize single or multiple energy applicators (or applicator arrays) and one or more microwave field-detecting needle assemblies. The single or multiple energy applicators and the one or more microwave field-detecting needle assemblies may be arranged in any suitable configuration.

[0084] Electrosurgical power generating source **26** may be any generator suitable for use with electrosurgical devices, and may be configured to provide various frequencies of electromagnetic energy. In some embodiments, the electrosurgical power generating source **26** is configured to provide microwave energy at an operational frequency from about 300 MHz to about 10 GHz. In other embodiments, the electrosurgical power generating source **26** is configured to provide electrosurgical energy at an operational frequency from about 400 KHz to about 500 KHz.

[0085] In some embodiments, the electrosurgical power generating source **26** is configured or set to a predetermined setting. For example, electrosurgical power generating source **26** may be set to a predetermined temperature, such as a temperature that may be used for the treatment of pain (e.g., about 42° C. or about 80° C.), a predetermined waveform, a predetermined duty cycle, a predetermined time period or duration of activation, etc.

[0086] Electrosurgical power generating source **26** may include a user interface **25** (FIG. **19**) in operable communication with a processor unit **82** (FIG. **19**). Processor unit **82**, which is described in more detail with respect to FIG. **19**, may be any type of computing device, computational circuit, or any type of processor or processing circuit capable of executing a series of instructions that are stored in a memory. In an embodiment, a physician may input via the user interface **25** a selected power output, and the microwave ablation control system **1800** controls the probe **12** to automatically adjust the ablation volume by changing the operating frequency of the probe **12**, e.g., based on at least one electrical signal transmitted by the one or more microwave field-detecting needle assemblies **100**.

[0087] In an embodiment, a physician may input via the user interface **25** a selected power output, and the microwave ablation control system **1800** controls the ablation field radiating about at least a portion of the energy applicator **12** into tissue based on one or more electrical signals transmitted by one or more microwave field-detecting needle assemblies **100**, e.g., by rotation of a energy applicator with a directional radiation pattern to avoid ablating sensitive structures, such as large vessels, healthy organs or vital membrane barriers and/or by controlling the electrosurgical power generating source **26** operatively associated with an energy applicator **12**.

[0088] During microwave ablation using the microwave ablation control system **1800**, one or more microwave field-detecting needle assemblies **100** may be inserted into tissue “T” and/or placed adjacent a sensitive structure “S”, and/or one or more microwave field-detecting needle assemblies **100** may be inserted into the abdominal wall “W” and/or into the abdominal cavity “C”. Probe **12** is inserted into tissue “T” and/or placed adjacent to a lesion “L”. Ultrasound or computed tomography (CT) guidance may be used to accurately guide the probe **12** into the area of tissue to be treated. Probe **12** and one or more microwave field-detecting needle assemblies **100** may be placed percutaneously or surgically, e.g., using conventional surgical techniques by surgical staff. After the one or more microwave field-detecting needle assemblies **100** and the probe **12** are positioned, microwave energy is supplied to the probe **12**.

[0089] A clinician may pre-determine the length of time that microwave energy is to be applied. Application duration may depend on many factors such as tumor size and location and whether the tumor was a secondary or primary cancer. The duration of microwave energy application using the probe **12** may depend on the progress of the heat distribution within the tissue area that is to be destroyed and/or the surrounding tissue. Treatment of certain tumors may involve probe repositioning during the ablation procedure, such as where the tumor is larger than the probe or has a shape that does not correspond with available probe geometry or radiation pattern.

[0090] FIG. **19** is a block diagram showing one embodiment of the electrosurgical power generating source **26** of FIG. **18**. In an embodiment, the generator module **86** is configured to provide energy of about 915 MHz. Generator module **86** may additionally, or alternatively, be configured to provide energy of about 2450 MHz (2.45 GHz). The present disclosure contemplates embodiments wherein the generator module **86** is configured to generate a frequency other than about 915 MHz or about 2450 MHz, and embodiments wherein the generator module **86** is configured to generate variable frequency energy. Electrosurgical power generating source **26** includes a processor **82** that is operably coupled to the user interface **25**. Processor **82** may include any type of computing device, computational circuit, or any type of processor or processing circuit capable of executing a series of instructions that are stored in a memory, e.g., storage device **88** or external device **91**.

[0091] In some embodiments, storage device **88** is operably coupled to the processor **82**, and may include random-access memory (RAM), read-only memory (ROM), and/or non-volatile memory (NV-RAM, Flash, and disc-based storage). Storage device **88** may include a set of program instructions executable on the processor **82** for executing a method for displaying and controlling ablation patterns in accordance with the present disclosure. Electrosurgical power generating source **26** may include a data interface **90** that is configured to provide a communications link to an external device **91**. In some embodiments, the data interface **90** may be any of a USB interface, a memory card slot (e.g., SD slot), and/or a network interface (e.g., 100BaseT Ethernet interface or an 802.11 “Wi-Fi” interface.) External device **91** may be any of a USB device (e.g., a memory stick), a memory card (e.g., an SD card), and/or a network-connected device (e.g., computer or server).

[0092] Electrosurgical power generating source **26** may also include a database **84** that is configured to store and

retrieve energy applicator data, e.g., parameters associated with one or energy applicators (e.g., **12** shown in FIGS. **18** and **19**). Parameters stored in the database **84** in connection with an energy applicator, or energy applicator array, may include, but are not limited to, energy applicator (or applicator array) identifier, energy applicator (or applicator array) dimensions, a frequency, an ablation length, an ablation diameter, a temporal coefficient, a shape metric, and/or a frequency metric. In an embodiment, ablation pattern topology may be included in the database **84**, e.g., a wireframe model of an applicator array and/or an ablation pattern associated therewith and/or an arrangement of microwave field-detecting needle assemblies for use in connection with one or more energy applicators.

[**0093**] Database **84** may also be maintained at least in part by data provided by the external device **91** via the data interface **90**. For example without limitation, data associated with energy applicator **12** may be uploaded from an external device **91** to the database **84** via the data interface **90**. Energy applicator data may additionally, or alternatively, be manipulated, e.g., added, modified, or deleted, in accordance with data and/or instructions stored on the external device **91**. In an embodiment, the set of energy applicator data represented in the database **84** is automatically synchronized with corresponding data contained in the external device **91** in response to the external device **91** being coupled (e.g., physical coupling and/or logical coupling) to the data interface **90**.

[**0094**] Processor **82** according to various embodiments is programmed to enable a user, via the user interface **25** and/or a display device (not shown), to view at least one ablation pattern and/or other data corresponding to an energy applicator or an applicator array. For example, a physician may determine that a substantially spherical ablation pattern is necessary. The physician may activate a “select ablation shape” mode of operation for electrosurgical power generating source **26**, preview an energy applicator array by reviewing graphically and textually presented data, optionally, or alternatively, manipulate a graphic image by, for example, rotating the image, and select an energy applicator or an applicator array, based upon displayed parameters. The selected energy applicator(s) may then be electrically coupled to the electrosurgical power generating source **26** for use therewith.

[**0095**] Electrosurgical power generating source **26** may include an actuator **87**. Actuator **87** may be any suitable actuator, e.g., a footswitch, a handswitch, an orally-activated switch (e.g., a bite-activated switch and/or a breath-actuated switch), and the like. Actuator **87** may be operably coupled to the processor **82** by a cable connection (e.g., **83** shown in FIG. **18**) or a wireless connection, e.g., a radiofrequency or infrared link.

[**0096**] In an embodiment, a physician may input via the user interface **25** an applicator array parameter to cause the electrosurgical power generating source **26** to present one or more electromagnetic energy delivery devices corresponding thereto and/or one or more microwave field-detecting needle assemblies for use therewith. For example, a physician may require a 3.0 cm×3.0 cm×3.0 cm ablation pattern, and provide an input corresponding thereto. In response, the electrosurgical power generating source **26** may preview a corresponding subset of available electromagnetic energy delivery devices that match or correlate to the inputted parameter.

[**0097**] In an embodiment, a physician may input via the user interface **25** a selected power output, and the electrosurgical system **1800** controls the energy applicator **12** to adjust the ablation field radiating about at least a portion of the energy applicator **12** into tissue based on at least one electrical signal transmitted by the one or more microwave field-detecting needle assemblies.

[**0098**] Hereinafter, a method of manufacturing a needle assembly in accordance with the present disclosure is described with reference to FIG. **20**, a method of manufacturing a microwave field-detecting needle assembly in accordance with the present disclosure is described with reference to FIG. **21**, and a method of adjusting an ablation field radiating into tissue is described with reference to FIG. **22**. It is to be understood that the steps of the methods provided herein may be performed in combination and in a different order than presented herein without departing from the scope of the disclosure.

[**0099**] FIG. **20** is a flowchart illustrating a method of manufacturing a needle assembly according to an embodiment of the present disclosure. In step **2010**, an inner-conductor pin **20** is provided. A retaining portion **23** is disposed at a distal end **22** of the inner-conductor pin **20**.

[**0100**] In step **2020**, a first outer-conductor structure **30** is joined to the retaining portion **23**.

[**0101**] In step **2030**, a tubular sleeve member **40** is positioned overlying a length of the inner-conductor pin **20** proximal to the retaining portion **23**. The tubular sleeve member **40** includes a longitudinally-extending internal chamber **45** configured to receive at least a portion of the inner-conductor pin **20** therein.

[**0102**] In step **2040**, a junction structure **50** is joined to the proximal end **31** of the first outer-conductor structure **30**, whereby the junction structure **50** is disposed around a portion of the tubular sleeve member **40**. The junction structure **50** includes a recess **56** defined therein. The distal end **52** of the junction member **50** may be provided with a series of external threads configured to matingly engage with a series of internal threads disposed at the proximal end **31** of the first outer-conductor structure **30**.

[**0103**] In step **2050**, a second outer-conductor structure **60** is joined to the proximal end **51** of the junction structure **50**. The proximal end **51** of the junction member **50** may be provided with a series of external threads configured to matingly engage with a series of internal threads disposed at the distal end **62** of the second outer-conductor structure **60**.

[**0104**] In step **2060**, a rectifier element **58** is positioned into the recess **56**. In some embodiments, the rectifier element **58** includes a first terminal **59a** and a second terminal **59b**. In such cases, the first terminal **59a** may be electrically coupled to the first outer-conductor structure **30** and the second terminal **59b** may be electrically coupled to the second outer-conductor structure **60**, e.g., by solder or other suitable electrical connection.

[**0105**] FIG. **21** is a flowchart illustrating a method of manufacturing a microwave field-detecting needle assembly according to an embodiment of the present disclosure. In step **2110**, a handle assembly **170** is provided. An electric circuit **300** is disposed within the handle assembly **170**.

[**0106**] In step **2120**, a needle assembly **110** is provided. The needle assembly **110** includes a first outer-conductor structure **30** coupled to an inner-conductor pin **20**, a junction structure **50** disposed between the first outer-conductor structure **30** and a second outer-conductor structure **60**, and

a rectifier element **58** disposed in a recess **56** defined in the junction structure **50**. A first terminal **59a** of the rectifier element **58** is electrically coupled to the first outer-conductor structure **30**, and a second terminal **59b** is electrically coupled to the second outer-conductor structure **60**.

[0107] In step **2130**, the inner-conductor pin **20** and the second outer-conductor structure **60** are electrically coupled to an electric circuit **300** disposed within the handle assembly **170**.

[0108] FIG. **22** is a flowchart illustrating a method of adjusting an ablation field radiating into tissue according to an embodiment of the present disclosure. In step **2210**, an energy applicator **12** is provided. In step **2220**, one or more microwave field-detecting needle assemblies **100** are provided. Each microwave field-detecting needle assembly **100** includes one or more rectifier elements **58** capable of detecting microwave field intensity via rectification.

[0109] In step **2230**, the energy applicator **12** and the one or more microwave field-detecting needle assemblies **100** are positioned in tissue. The energy applicator **12** may be inserted directly into tissue, inserted through a lumen, e.g., a vein, needle, endoscope or catheter, placed into the body during surgery by a clinician, or positioned in the body by other suitable methods known in the art. The energy applicator **12** may be configured to operate with a directional radiation pattern. The one or more microwave field-detecting needle assemblies **100** may be positioned in material, e.g., tissue, by any suitable method and arranged in any configuration (e.g., configuration shown in FIG. **18**).

[0110] In step **2240**, energy is transmitted from an energy source **26** through the energy applicator **12** to generate an ablation field radiating about at least a portion of the energy applicator **12** into tissue. The energy source **26** may be any suitable electrosurgical generator for generating an output signal. In some embodiments, the energy source **26** is a microwave energy source, and may be configured to provide microwave energy at an operational frequency from about 300 MHz to about 10 GHz.

[0111] In step **2250**, the ablation field radiating about at least the portion of the energy applicator **12** into tissue is adjusted based on at least one electrical signal transmitted by the one or more microwave field-detecting needle assemblies **100**. In some embodiments, adjusting the ablation field radiating about at least the portion of the energy applicator **12** into tissue, in step **2250**, may include adjusting at least one operating parameter associated with the energy source **26** based on the at least one electrical signal transmitted by the one or more microwave field-detecting needle assemblies **100**. Examples of operating parameters associated with the energy source **26** include temperature, impedance, power, current, voltage, mode of operation, and duration of application of electromagnetic energy.

[0112] According to various embodiments of the present disclosure, the above-described microwave field-detecting needle assembly enables physicians to detect field intensity in proximity to an energy-delivery device. The presently-disclosed microwave field-detecting needle assembly embodiments may allow the physician to determine if a microwave field is strong enough for the intended purpose or to achieve a desired surgical outcome.

[0113] The presently-disclosed microwave field-detecting needle assembly embodiments may be suitable for utilization in minimally invasive procedures, e.g., endoscopic and laparoscopic surgical procedures. The above-described

microwave field-detecting needle assembly embodiments may be suitable for utilization in open surgical applications.

[0114] Various embodiments of the presently-disclosed microwave field-detecting needle assembly embodiments may allow the physician to determine when a microwave ablation probe is inserted to a proper depth within tissue, e.g., to reach the location of the ablation site and/or to avoid unintended field exposure. Various embodiments of the presently-disclosed microwave field-detecting needle assembly are adapted to be coupled in communication with a stand-alone control unit.

[0115] Electrosurgical systems including one or more microwave field-detecting needle assemblies according to embodiments of the present disclosure may protect sensitive structures, ensure expected field pattern and/or protect the abdominal wall from stray microwave fields.

[0116] The above-described microwave field-detecting needle assemblies may be used to detect microwave field intensity emitted by an energy applicator, and an electrical signal transmitted from the presently-disclosed microwave field-detecting needle assemblies may be used to control the positioning of an electrosurgical device (e.g., rotation of a energy applicator with a directional radiation pattern to avoid ablating sensitive structures, such as large vessels, healthy organs or vital membrane barriers), and/or control an electrosurgical power generating source operatively associated with an energy applicator.

[0117] Although embodiments have been described in detail with reference to the accompanying drawings for the purpose of illustration and description, it is to be understood that the inventive processes and apparatus are not to be construed as limited thereby. It will be apparent to those of ordinary skill in the art that various modifications to the foregoing embodiments may be made without departing from the scope of the disclosure.

1-20. (canceled)

21. A microwave ablation control system, comprising:

a microwave field-detecting tool configured to detect an intensity of a microwave field emitted by an energy-delivery device, the microwave field-detecting tool including a junction structure configured to couple to a rectifier element; and

a control unit in communication with the microwave field-detecting tool, the control unit configured to adjust energy delivered by an energy-delivery device based on the intensity detected by the microwave field-detecting tool.

22. The microwave ablation control system of claim **21**, wherein the rectifier element is configured to convert alternating current (AC) to direct current (DC).

23. The microwave ablation control system of claim **21**, wherein the rectifier element comprises one or more diode, Zener diode, Schottky diode or tunnel diode.

24. The microwave ablation control system of claim **21**, further comprising an inductor-regulator-capacitor low-pass filter circuit configured to convert a rectified sinusoidal waveform from the rectifier element into an electrical signal.

25. The microwave ablation control system of claim **21**, wherein the junction structure is disposed between a distal portion and a proximal portion of the microwave field-detecting tool.

26. The microwave ablation control system of claim **21**, further comprising a handle assembly operably coupled to a proximal portion of the microwave field-detecting tool.

27. The microwave ablation control system of claim **26**, further comprising an electric circuit disposed within the handle assembly, the electric circuit including an indicator unit configured to generate at least one of a visual signal or an audio signal.

28. The microwave ablation control system of claim **26**, further comprising a cable assembly electrically coupled to the microwave field-detecting tool via the handle assembly, the cable assembly having a proximal portion configured to connect to the control unit, the cable assembly.

29. The microwave ablation control system of claim **21**, wherein the microwave field-detecting tool includes a first outer-conductor structure and a second outer-conductor structure, the first and second outer-conductor structures separated by the junction structure.

30. The microwave ablation control system of claim **29**, wherein the junction structure is configured to diagonally separate the first outer-conductor structure and the second outer-conductor structure.

31. The microwave ablation control system of claim **21**, further comprising an electro-surgical energy generating

source operably coupled to the microwave field-detecting tool, the electro-surgical energy generating source including a processor unit configured to adjust at least one operating parameter associated with the electro-surgical energy generating source based on an electrical signal transmitted by the microwave field-detecting tool.

32. The microwave ablation control system of claim **31**, wherein the at least one operating parameter associated with the electro-surgical energy generating source is selected from the group consisting of temperature, impedance, power, current, voltage, mode of operation, and duration of application of electro-surgical energy.

33. The microwave ablation control system of claim **21**, further comprising an energy-delivery device configured to transmit microwave energy, wherein the microwave field-detecting tool is configured to be inserted into tissue independently from the energy-delivery device.

34. The microwave ablation control system of claim **21**, wherein the microwave field-detecting tool is a needle having a tapered distal tip.

* * * * *

专利名称(译)	微波场检测针组件，其制造方法，使用其调节消融场的辐射场的方法，以及包括该组件的系统		
公开(公告)号	US20160287330A1	公开(公告)日	2016-10-06
申请号	US15/177729	申请日	2016-06-09
[标]申请(专利权)人(译)	柯惠有限合伙公司		
申请(专利权)人(译)	COVIDIEN LP		
当前申请(专利权)人(译)	COVIDIEN LP		
[标]发明人	BRANNAN JOSEPH D		
发明人	BRANNAN, JOSEPH D.		
IPC分类号	A61B18/18 H01Q1/24 G01R29/08 A61B18/14 A61B5/00		
CPC分类号	A61B18/1815 A61B2018/1869 A61B5/4836 G01R29/0878 G01R29/0871 H01Q1/248 A61B2018/00577 A61B2018/00642 A61B2018/00702 A61B2018/00714 A61B2018/0072 A61B2018/00755 A61B2018/00761 A61B2018/00767 A61B2018/1427 A61B2018/1823 A61B18/1477		
外部链接	Espacenet	USPTO	

摘要(译)

调节辐射到组织中的消融场的方法包括提供能量施加器和提供一个或多个微波场检测针组件的初始步骤。每个微波场检测针组件包括一个或多个能够通过整流检测微波场强度的整流器元件。该方法包括以下步骤：将能量施加器和一个或多个微波场检测针组件定位在组织中，从能量源通过能量施加器传输能量，以产生围绕能量施加器的至少一部分辐射的消融场。组织，并基于由一个或多个微波场检测针组件传输的至少一个电信号，调节围绕能量施加器的至少一部分辐射到组织中的消融场。

