



US 20150150506A1

(19) **United States**  
(12) **Patent Application Publication**  
**WOO**

(10) **Pub. No.: US 2015/0150506 A1**  
(43) **Pub. Date: Jun. 4, 2015**

(54) **DETACHABLE BIOLOGICAL SIGNAL MEASURING PAD AND BIOLOGICAL SIGNAL MEASURING APPARATUS USING THE SAME**

**Publication Classification**

(51) **Int. Cl.**  
*A61B 5/00* (2006.01)  
(52) **U.S. Cl.**  
CPC ..... *A61B 5/6833* (2013.01); *A61B 5/0022* (2013.01); *A61B 5/7225* (2013.01)

(71) Applicant: **UMEDIX CORPORATION LIMITED**, Seongnam city (KR)

(72) Inventor: **Sung Hun WOO**, Suwon-city (KR)

(21) Appl. No.: **14/614,468**

(57) **ABSTRACT**

(22) Filed: **Feb. 5, 2015**

**Related U.S. Application Data**

(62) Division of application No. 13/810,094, filed on Jan. 14, 2013, now Pat. No. 9,014,777, filed as application No. PCT/KR2011/005437 on Jul. 22, 2011.

**Foreign Application Priority Data**

Jul. 23, 2010 (KR) ..... 10-2010-0071180  
Jul. 23, 2010 (KR) ..... 10-2010-0071181

Disclosed is a detachable biological signal measuring pad that measures biological signals such as a pulse or body temperature. The biological signal measuring pad includes an adhesive pad main body detachably adhered to a body, a biological signal detecting electrode provided on an adhesive surface of the main body adhered to the body, and a module chip including a memory card mounted on the main body so as to be connected with the electrode and storing biological signals measured in the electrode, and provided on a surface opposite to the adhesive surface.

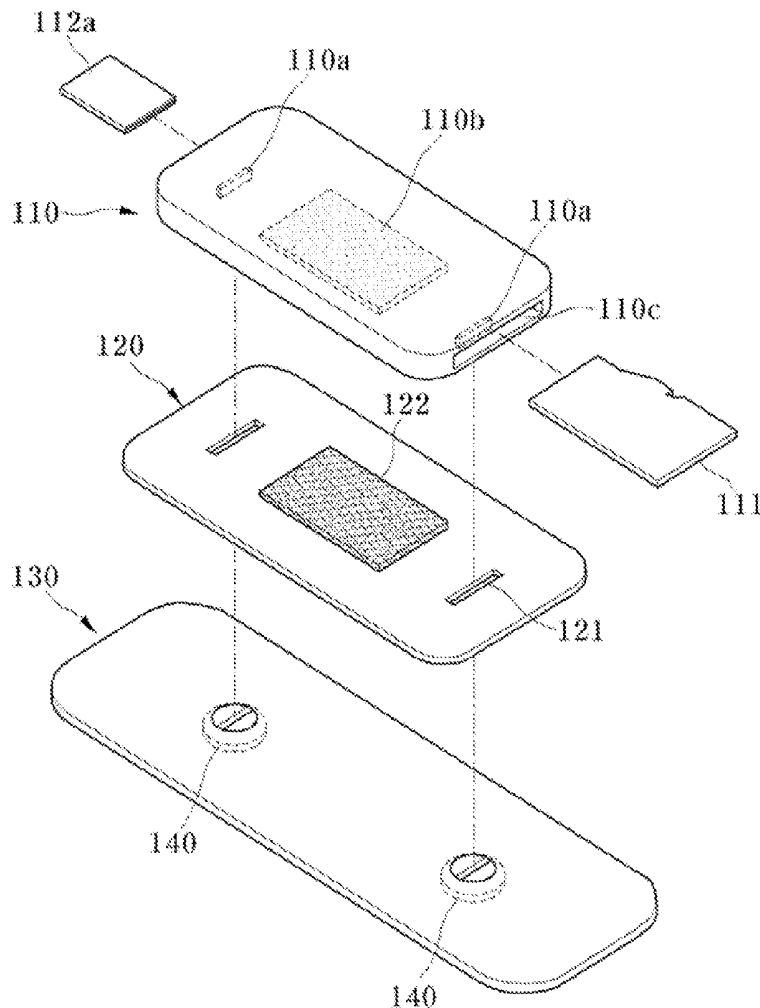

FIG. 1

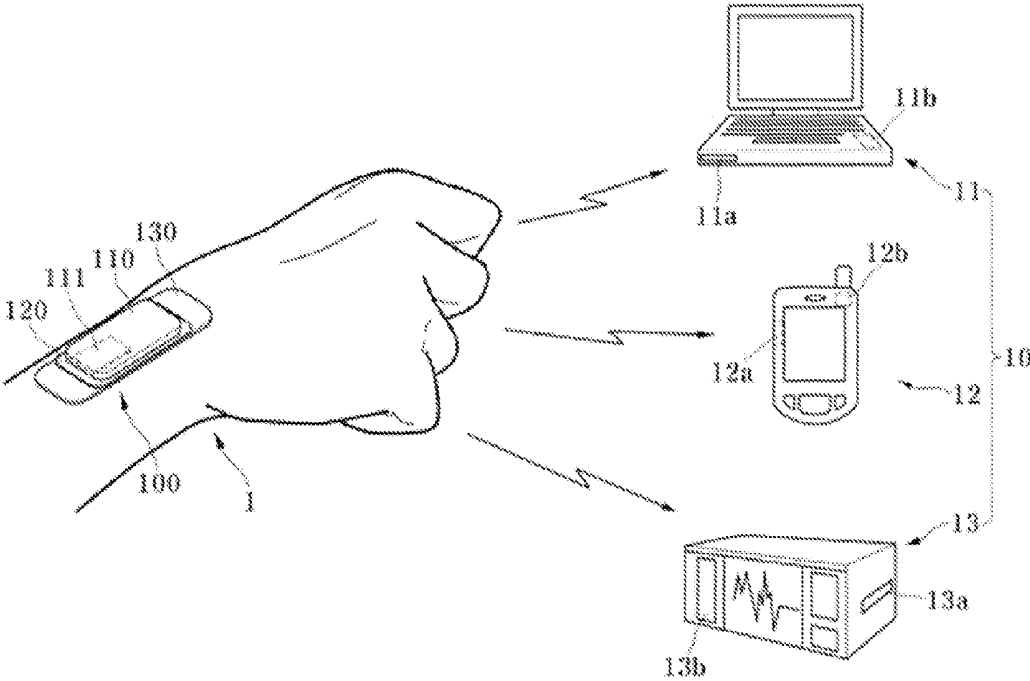

FIG. 2

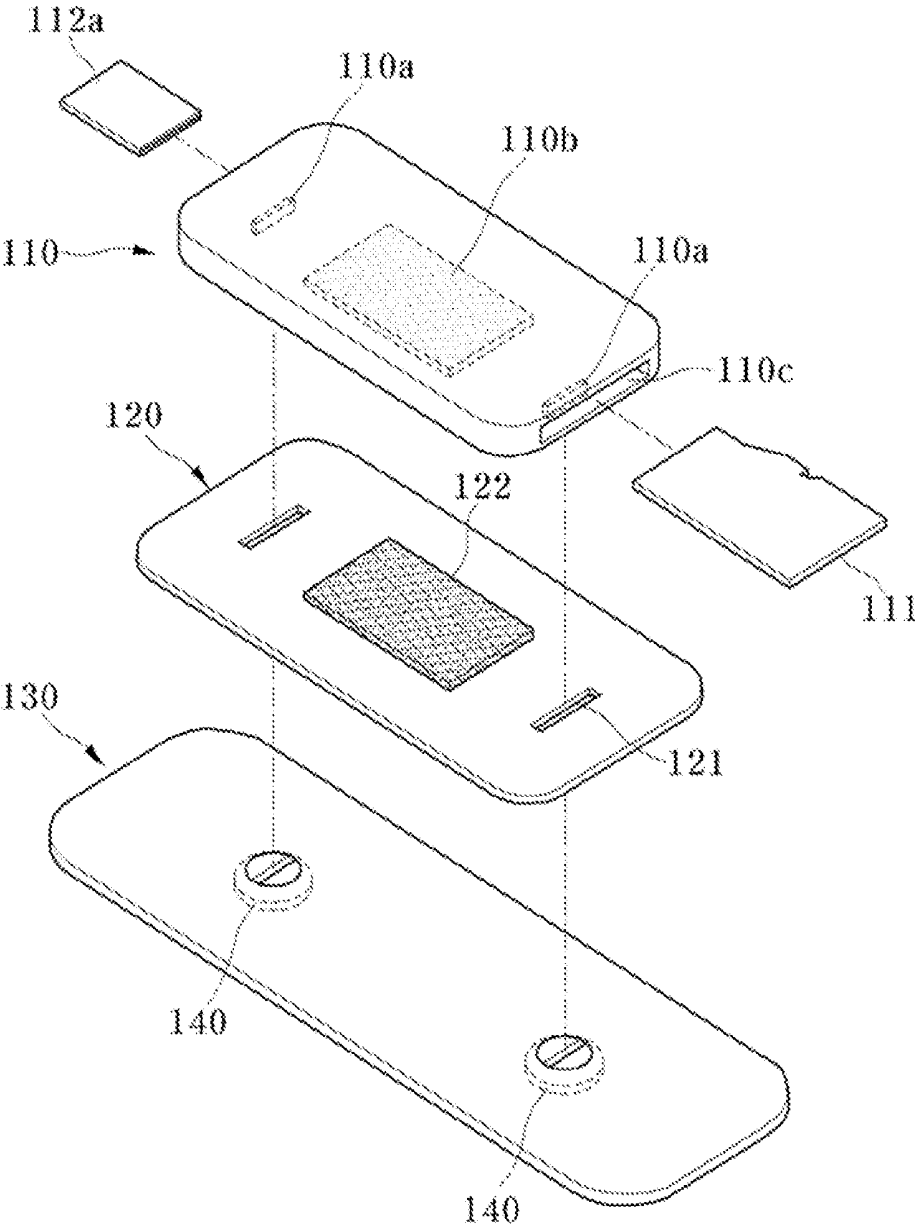

FIG. 3

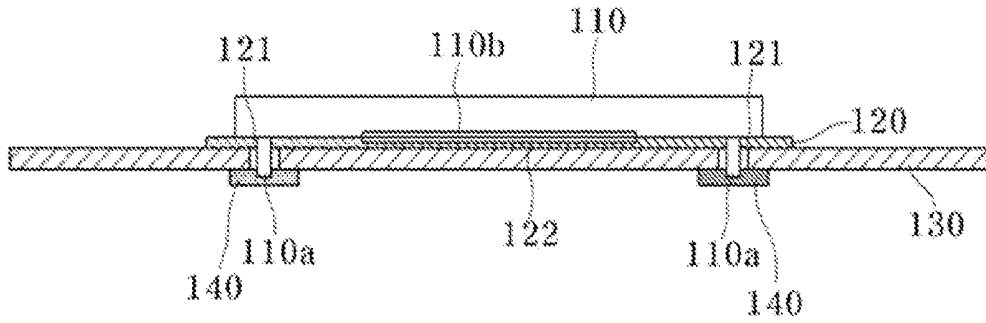

FIG. 4

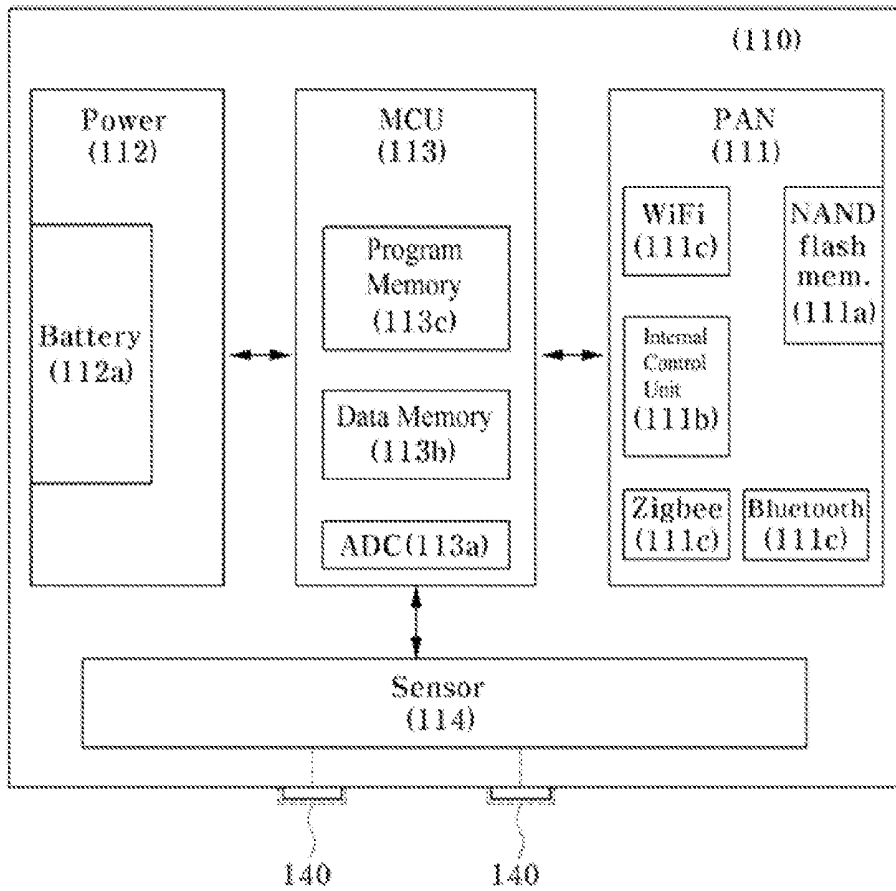

FIG. 5

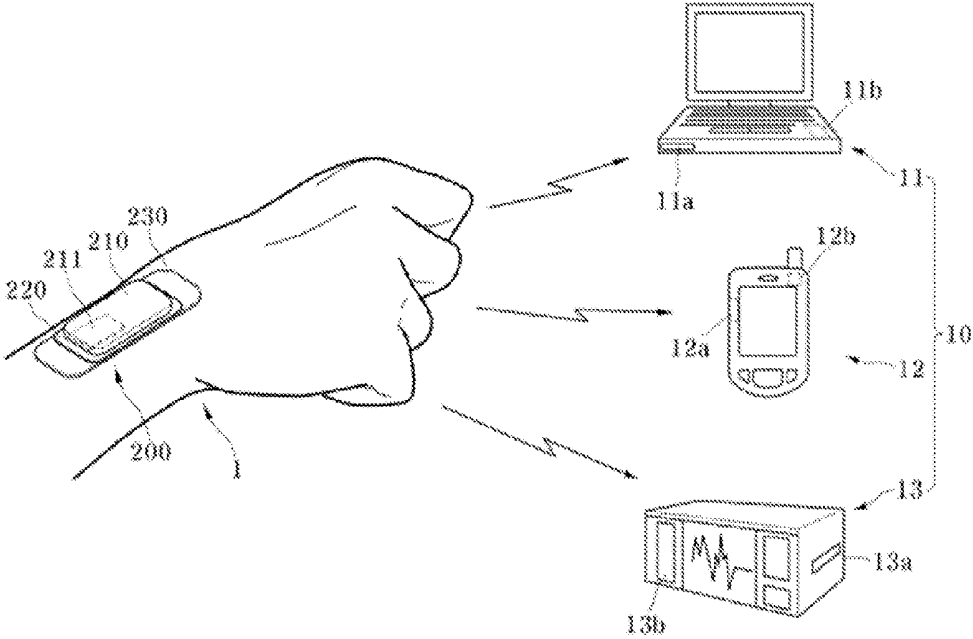

FIG. 6

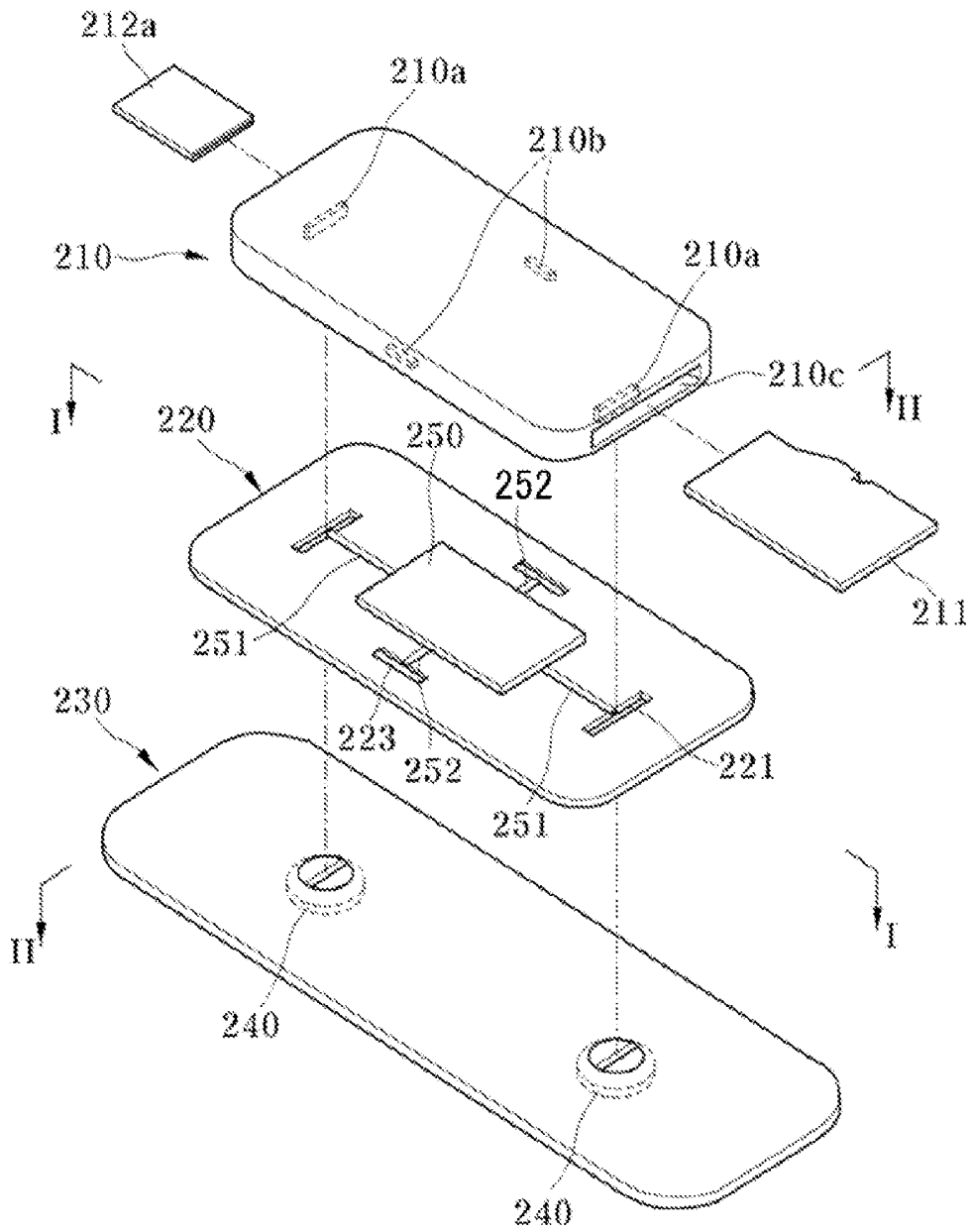

FIG. 7

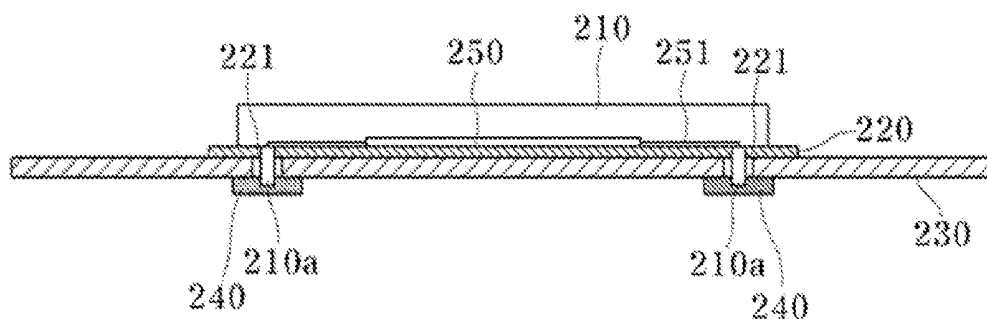

FIG. 8

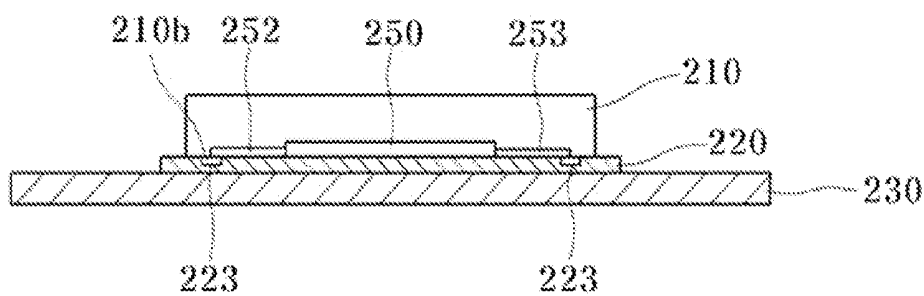

FIG. 9

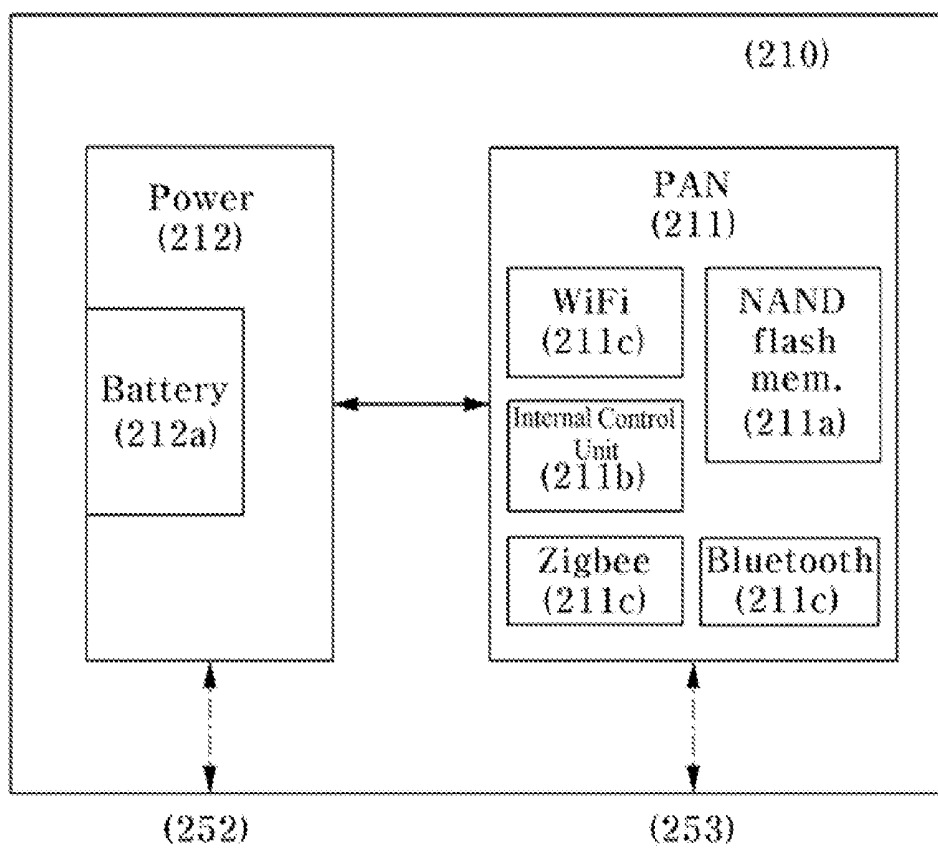
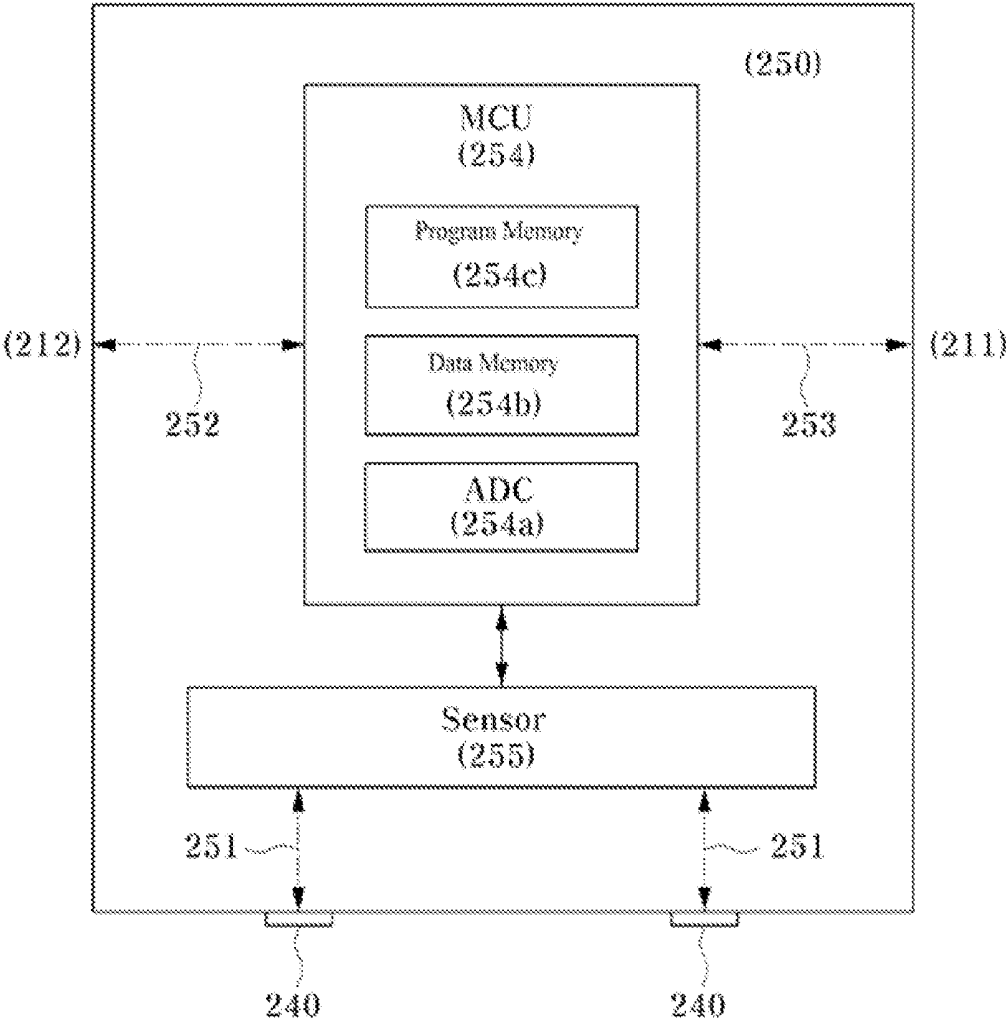

FIG. 10



**DETACHABLE BIOLOGICAL SIGNAL  
MEASURING PAD AND BIOLOGICAL  
SIGNAL MEASURING APPARATUS USING  
THE SAME**

CROSS REFERENCE TO PRIOR APPLICATIONS

**[0001]** This application is a Divisional Application of U.S. patent application Ser. No. 13/810,094 (filed on Jan. 14, 2013) under 35 U.S.C. §121, which is a National Stage Patent Application of PCT International Patent Application No. PCT/KR2011/005437 (filed on Jul. 22, 2011) under 35 U.S.C. §371, which claims priority to Korean Patent Application Nos. 10-2010-0071180 (filed on Jul. 23, 2010) and 10-2010-0071181 (filed on Jul. 23, 2010), which are all hereby incorporated by reference in their entirety.

BACKGROUND

**[0002]** The present invention relates to a detachable biological signal measuring pad and a biological signal measuring apparatus using the same, and more particularly, to a detachable biological signal measuring pad that may greatly improve portability and ease of use, and a biological signal measuring apparatus using the same.

**[0003]** With the advent of the well-being age in recent years, concern about health is gradually growing, and especially early identification and management of the health status of individuals has been known as the most important issue to maintain a healthy life. In particular, well monitoring of biological signals from the body such as pulse or body temperature with respect to health care groups such as the elderly or the chronically ill, is to prevent misfortune such as rapid degradation of the quality of life, and therefore the importance of good understanding of one's health status has been further emphasized. However, as society is gradually aging and population of the elderly is increasing, the number of the chronically ill is increasing due to the westernization of eating habits, whereas an environment to identify and manage biological signals associated with the health of the individuals has not been significantly improved. That is, the number of persons of the health care group whose health status needs to be particularly well-managed is increasing, but an environment to frequently measure the health status of each individual is not actually established. Typically, because a person who wishes to identify their health status has to use examination equipment provided from a medical institution, it is difficult to frequently identify his/her health status, and therefore persons of the health care group having severe ups and downs in their health status have low efficiency. In recent years, home inspection equipment capable of measuring biological signals at home such as an electrocardiogram has been released, but is generally too big and heavy to move, and only measured results are obtainable, and therefore, it is difficult for a user to directly determine which action he/she should take from the measured results unless the user goes again to a medical facility to enquire and seek advice. Accordingly, there is a demand for a new type of system for measuring biological signals that may be more easily portable, and improve utilization of measured results.

SUMMARY

**[0004]** The present invention is directed to a detachable biological signal measuring pad which may be more easily

portable and improve utilization of measured results, and a biological signal measuring apparatus using the same.

**[0005]** According to an aspect of the present invention, there is provided a detachable biological signal measuring pad, including: an adhesive pad main body detachably adhered to a body; a biological signal detecting electrode provided on an adhesive surface of the main body adhered to the body; and a module chip including a memory card mounted on the main body so as to be connected with the electrode and storing biological signals measured in the electrode, and provided on a surface opposite to the adhesive surface.

**[0006]** According to another aspect of the present invention, there is provided a biological signal measuring apparatus including: a detachable biological signal measuring pad including an adhesive pad main body detachably adhered to a body, a biological signal detecting electrode provided on an adhesive surface of the main body adhered to the body, and a module chip including a memory card mounted on the main body so as to be connected with the electrode and storing biological signals measured in the electrode; and an analysis device receiving and analyzing the biological signals stored in the memory card.

**[0007]** According to still another aspect of the present invention, there is provided a detachable biological signal measuring pad including: a pad main body detachably adhered to a body; a biological signal detecting electrode provided on an adhesive surface of the main body adhered to the body; a card module chip including a memory card for storing the biological signals measured in the electrode and a power supply unit for supplying power mounted therein, and provided on a surface opposite to the adhesive surface so as to be physically connected with the electrode; a connecting pad provided between the electrode of the main body and the card module chip, and including a connecting means for physically connecting the module chip and the electrode, the connecting means including a connecting pin protruding from the card module chip and a plug groove connected with the electrode and formed on the connecting pad so as to receive the connecting pin; and a sensing module provided on the connecting pad so as to be electrically connected with the plug groove of the connecting means, and including a sensing unit for amplifying the biological signals from the electrode transmitted through the plug groove and removing noise.

**[0008]** According to yet another aspect of the present invention, there is provided a biological signal measuring apparatus including: a system-on-chip biological signal measuring pad including a card module chip in which a memory card is mounted; and an analysis device receiving and analyzing the biological signals stored in the memory card, wherein the system-on-chip biological signal measuring pad includes an adhesive pad main body detachably adhered to a body, a biological signal detecting electrode provided on an adhesive surface of the main body adhered to the body, a card module chip including a memory card for storing the biological signals measured in the electrode and a power supply unit for supplying power mounted therein, and provided on a surface opposite to the adhesive surface so as to be physically connected with the electrode, and a connecting pad provided between the electrode of the main body and the card module chip, and including a connecting means for physically connecting the card module chip and the electrode and a sensing module chip provided on the connecting pad so as to be electrically connected with a plug groove, wherein the con-

necting means includes a connecting pin protruding from the card module chip and the plug groove formed on the connecting pad so as to receive the connecting pin, and wherein the sensing module chip includes a sensing unit for amplifying the biological signals from the electrode transmitted through the plug groove and removing noise.

[0009] As described above, according to the embodiments of the present invention, the detachable biological signal measuring pad may be easily carried by a user, and therefore the health status of the user may be conveniently measured anytime and anywhere. In addition, the detachable biological signal measuring pad may be communicated with the analysis device by loading the detachable memory card in the analysis device or using wireless communication, and therefore the measured results are rapidly utilized. As a result, rapid measuring and utilization of the biological signals are achieved to thereby realize a healthy society.

[0010] In addition, in the detachable biological signal measuring pad, the sensing module chip and the card module chip are separately implemented, and therefore the detachable biological signal measuring pad may be attached and detached according to a variety of applications. As a result, the size of the detachable biological signal measuring pad may be further reduced, and power consumption may be further reduced. In particular, the detachable biological signal measuring pad may be replaced in accordance with a variety of biological signals such as ECG waveforms, EEG waveforms, EMG waveforms, pulse waveforms, body temperature, blood sugar, and the like, and simultaneously measure the above-described biological signals.

#### BRIEF DESCRIPTION OF THE DRAWINGS

[0011] FIG. 1 is a drawing showing a configuration of a biological signal measuring apparatus including a detachable biological signal measuring pad according to a first embodiment of the present invention;

[0012] FIG. 2 is an exploded perspective view showing the detachable biological signal measuring pad shown in FIG. 1;

[0013] FIG. 3 is a cross-sectional view showing a coupling state of FIG. 2;

[0014] FIG. 4 is a drawing showing an internal configuration of a module chip of the detachable biological signal measuring pad shown in FIG. 2;

[0015] FIG. 5 is a drawing showing a configuration of a biological signal measuring apparatus including a detachable biological signal measuring pad according to a second embodiment of the present invention;

[0016] FIG. 6 is an exploded perspective view showing the detachable biological signal measuring pad shown in FIG. 5;

[0017] FIGS. 7 and 8 are cross-sectional views showing a coupling state of FIG. 6;

[0018] FIG. 9 is a drawing showing an internal configuration of a card module chip of the detachable biological signal measuring pad shown in FIG. 6; and

[0019] FIG. 10 is a drawing showing an internal configuration of a sensing module chip of the detachable biological signal measuring pad shown in FIG. 6.

#### DETAILED DESCRIPTION

[0020] Exemplary embodiments of the present invention will be described in detail below with reference to the accompanying drawings. While the present invention is shown and described in connection with exemplary embodiments

thereof, it will be apparent to those skilled in the art that various modifications can be made without departing from the spirit and scope of the invention.

[0021] Hereinafter, preferred embodiments of the present invention will be described in detail with reference to the accompanying drawings.

[0022] FIG. 1 is a drawing schematically showing a system configuration of a biological signal measuring apparatus according to a first embodiment of the present invention. As shown in FIG. 1, the biological signal measuring apparatus according to the present invention includes a detachable biological signal measuring pad 100 that may be attached and detached to and from a user's body such as a wrist 1, like a band-aid, and an analysis device 10 that receives and analyzes biological signals measured in the measuring pad 100. That is, when the biological signal measuring pad 100 is attached to a user's skin, biological signals such as a pulse or body temperature may be measured and recorded in a memory card 111 mounted in the pad 100, the recorded information may be analyzed which is transmitted to a mobile phone 12 or a dedicated terminal 13 such as a computer 11 of a medical institution or a smart phone, and then the analyzed information may be provided to the user as useful information. Here, as an example, a case in which the measuring pad 100 is attached to the wrist 1 has been described, but the measuring pad 100 may be attached to the chest or the head, as necessary, and the measured biological signals encompass electrocardiogram (ECG) waveforms, electro-encephalogram (EEG) waveforms, electromyogram (EMG) waveforms, pulse waveforms, a body temperature, a blood sugar, and the like.

[0023] Accordingly, a user attaches the biological signal measuring pad 100 to an appropriate body region so as to measure biological signals, as necessary, while carrying the biological signal measuring pad 100 like a band-aid, and transmits the measured biological signals to the analysis device 10 to check his/her own health status and required measures. As a method of transmitting the biological signals to the analysis device 10, both a method in which the memory card 111 mounted on the measuring pad 100 is pulled and directly inserted into card slots 11a, 12a, and 13a of the analysis device 10 to thereby load measured data, and a method in which the biological signals are transmitted to the communication modules 11b, 12b, and 13b of the analysis device 10 in a wireless manner using a personal area network (PAN), may be used.

[0024] Hereinafter, the biological signal measuring pad 100 according to an embodiment of the present invention which is configured so as to implement the above-described function will be described in detail. FIGS. 2 and 3 are drawings respectively showing an exploded state and a coupling state of a structure of the biological signal measuring pad 100, and FIG. 4 is a drawing showing an internal structure of the module chip 110 that is a core component.

[0025] First, referring to FIGS. 2 and 3, the biological signal measuring pad 100 includes an adhesive pad main body 130 capable of attaching to skin, a module chip 110 in which a memory card 111 and a battery 112a are detachably inserted through a slot 110c, and a connecting pad 120 interposed between the pad main body 130 and the module chip 110.

[0026] A bottom surface of the pad main body 130 is an adhesive surface attached to skin, and a pair of electrodes 140 for measuring biological signals is mounted on the adhesive surface. That is, when attaching the measuring pad 100 to skin, the pair of electrodes 140 are brought into contact with

the skin, and receive biological signals such as a pulse or body temperature as electrical signals. Next, the pair of electrodes **140** are connected with a connecting pin **110a** of the module chip **110** through a connecting means provided in a connecting pad **120**. Accordingly, the biological signals received through the electrode **140** are transmitted to the module chip through the connecting pin **110a**. A process of processing signals in the module chip **110** will be described below with reference to FIG. 4. A reference numeral **121** indicates a plug groove composed of the connecting means for connecting the electrode **140** and the module chip **110** together with the connecting pin **110a**. That is, the connecting pin **110a** of the module chip **110** is connected to the electrode **140** provided on the pad main body **130** through the plug groove **121** of the connecting pad **120**. Preferably, adhesive members **110b** and **122** adhered to each other are provided above the connecting pad **120** and below the module chip **110**. Obviously, a binding force through forcible coupling between the connecting pin **110a** and the electrode **140** is maintained, but the adhesive members **110b** and **122** more firmly fix the module chip **110**. The pad main body **130** and the connecting pad **120** are coupled with each other through an adhesive.

[0027] Next, an internal configuration of the module chip **110** will be described with reference to FIG. 4.

[0028] As shown in FIG. 4, the module chip **110** includes a sensing unit **114** that amplifies the biological signals from the electrode **140** and removes noise, a microcomputer unit **113** that controls the module chip **110** by processing the biological signals input from the sensing unit **114** and storing the processed biological signals in the memory card **111**, and a power supply unit **112** that supplies power to the module chip **110**. As described in FIG. 2, the memory card **111** and the battery **112a** are attached and detached to and from the module chip **110** through the slot **110c**, the battery **112a** inserted into the module chip **110** is mounted in the power supply unit **112**, and the memory card **111** is mounted so as to be connected with the microcomputer unit **113**. The microcomputer unit **113** includes an AD converter **113a** for converting the biological signals received through the sensing unit **114** from analog signals to digital signals, a data memory **113b** for storing the biological signals converted into the digital signals, and a program memory **113c** for storing a program controlling the module chip **110**. Accordingly, the analog biological signals received from the sensing unit **114** in accordance with the program stored in the program memory **113c** are converted into digital signals through the AD converter **113a**, stored in the data memory **113b**, transmitted to the memory card **111**, and then stored in the memory unit **111a**. The memory card **111** includes a memory unit **111a** for storing the measured digital signals, a communication unit **111c** for transmitting the stored biological signals to the outside, and an internal control unit for controlling storage and transmission in accordance with a control of the module chip **110**. The internal control unit **111b** may compress or encrypt data. The communication unit **111c** may include zigbee, Bluetooth, WiFi, or the like, as PAN. Accordingly, the biological signal data stored in the memory unit **111a** may be transmitted by communicating with the communication modules **11b**, **12b**, and **13b** of the analysis device **10** through the communication unit **111c** as described above. Alternatively, the biological signal data may be transmitted in such a manner that the memory card **111** itself is pulled out from the module chip **110**, and then is loaded which is inserted into the card slots **11a**, **12a**, and **13a** of the analysis device **10**.

[0029] The biological signal measuring apparatus described as above may be utilized as follows.

[0030] As shown in FIG. 1, a user attaches the biological signal measuring pad **100** to an appropriate body region when wishing to measure his own health status while carrying the biological signal measuring pad **100**. Here, a case in which a user attaches the pad **100** to his own wrist **1** to measure a pulse waveform is assumed. Obviously, in this instance, the memory card **111** for data storage and communication and the battery **112a** that is a power source, should be mounted in the module chip **110**. Before attaching the pad **100** to the body, a conductive gel may be attached to the electrode **140**. In this manner, when attaching the pad **100** to the wrist **1**, analog biological signals such as pulse waveforms are measured through the electrode **140**, and the measured analog biological signals are transmitted to the module chip **110** through the connecting pin **110a** connected with the electrode **140**. The analog signals transmitted into the module chip **110** are amplified in the sensing unit **114**, converted into digital signals in the AD converter **113a**, and then stored in the data memory **113b** and the memory unit **111a** of the memory card **111**. In this state, when the user wishes to check analyzed results by immediately transmitting the measured biological signals to the analysis device **10**, data may be transmitted in such a manner that the communication unit **111c** is connected with the communication modules **11a**, **12a**, and **13a** of the analysis device **10** in a wireless manner. Although not shown in the drawings, a transmission button may be provided on one side of the module chip **110**, and the internal control unit **111b** operates the communication unit **111c** to thereby initiate wireless communication when a corresponding button is pushed by a user. Alternatively, a user pulls the memory card **111** out from the module chip **110**, and directly mounts the memory card **111** in the analysis device **10** to thereby transmit data.

[0031] The analysis device **10** analyzes the transmitted biological signals, and informs diagnostic results suitable for the analyzed signals. When the pulse waveform measured by the user is in a normal range, the analysis device **10** informs a corresponding diagnostic result as normal, and when the pulse waveform is in an abnormal range such as bradycardia or pyknoecardia, the analysis device **10** informs required measures such as recommending diagnosis of a corresponding health status and consultation with experts, or the like. Then, the user may well manage his health status by appropriately performing corresponding measures.

[0032] Therefore, by utilizing the detachable biological signal measuring pad and apparatus, a user may conveniently measure his own health status anytime and anywhere, and communicate with the analysis device by loading the detachable memory card in the analysis device or using wireless communication, and therefore the measured results are rapidly utilized. As a result, rapid measuring and utilization of the biological signals are achieved to thereby realize a healthy society.

[0033] FIG. 5 is a drawing schematically showing a system configuration of a biological signal measuring apparatus according to a second embodiment of the present invention.

[0034] As shown in FIG. 5, the biological signal measuring apparatus of the present invention includes a detachable biological signal measuring pad **200** that is detachably adhered to a user's body such as a wrist **1** like a band-aid, and an analysis device **10** that receives and analyzes the biological signals measured in the measuring pad **200**. That is, when the

biological signal measuring pad 200 is attached to a user's skin, biological signals such as a pulse or a body temperature are measured and recorded in the memory card 211 mounted in the pad 200, the recorded information is analyzed which is transmitted to a computer 11 of the medical institution, a mobile phone such as a smart phone, or a dedicated terminal 13, and then transmitted to the user as useful information. Here, as an example, a case in which the measuring pad 200 is attached to the wrist 1 has been described, but the measuring pad 200 may be attached to the chest or the head, as necessary, and the measured biological signals encompass ECG waveforms, EEG waveforms, EMG waveforms, pulse waveforms, a body temperature, a blood sugar, and the like.

[0035] Accordingly, a user attaches the biological signal measuring pad 200 to an appropriate body region so as to measure biological signals, as necessary, while carrying the biological signal measuring pad 200 like a band-aid, and transmits the measured biological signals to the analysis device 10 to check his own health status and required measures.

[0036] As a method of transmitting the biological signals to the analysis device 10, both a method in which the memory card 211 mounted on the measuring pad 200 is pulled and directly inserted into card slots 11a, 12a, and 13a of the analysis device 10 to thereby load measured data, and a method in which the biological signals are transmitted to the communication modules 11b, 12b, and 13b of the analysis device 10 in a wireless manner using PAN, may be used.

[0037] Hereinafter, the biological signal measuring pad 200 according to an embodiment of the present invention which is configured so as to implement the above-described function will be described in detail. FIG. 6 is a drawing showing an exploded state of a structure of the biological signal measuring pad 200, and FIGS. 7 and 8 are drawings respectively showing a coupling state of the biological signal measuring pad 200. FIGS. 9 and 10 are drawings respectively showing an internal structure of a card module chip 210 and a sensing module 250 which are core components.

[0038] First, referring to FIGS. 6 to 8, the biological signal measuring pad 200 includes an adhesive pad main body 230 capable of attaching to skin, a module chip 210 in which a memory card 211 and a battery 212a are detachably inserted through a slot 210c, a connecting pad 220 interposed between the adhesive pad main body 230 and the card module chip 210, and a sensing module 250 provided on the connecting pad 220.

[0039] In the drawings, a bottom surface of the pad main body 230 is an adhesive surface attached to skin, and a pair of electrodes 240 for measuring biological signals is mounted on the adhesive surface. That is, when attaching the measuring pad 200 to the skin, the pair of electrodes 240 are brought into contact with the skin, and receive biological signals such as a pulse or a body temperature as electrical signals. Next, the pair of electrodes 240 are physically coupled with a connecting pin 210a of the module chip 210 through a connecting means provided in a connecting pad 220. Accordingly, the biological signals received through the electrode 240 are transmitted to the module chip through the connecting pin 210a. A reference numeral 221 indicates a plug groove constituting the connecting means for connecting the electrode 240 and the module chip 210 together with the connecting pin 210a. That is, the connecting pin 210a of the module chip 210 is connected to the electrode 240 provided on the pad main body 230 through the plug groove 221 of the connecting pad

220. Accordingly, the card module chip 210 and the connecting pad 220 are physically coupled with the electrode 240. In addition, the plug grooves 221 of the connecting pad 220 are electrically connected with the sensing module 250 provided on the connecting pad 220 through a wire 251. Accordingly, biological signals received through the electrode 240 are transmitted to the sensing module 250 through the connecting pin 210a. The pad main body 230 and the connecting pad 220 are coupled with each other using an adhesive. A configuration of the card module chip 210 and a signal processing process in the sensing module chip 250 will be described below with reference to FIGS. 9 and 10.

[0040] Preferably, the connecting pad may further include a signal connection means for electrically connecting the sensing module chip 250 and the card module chip 210. A reference numeral 223 indicates a signal connection groove constituting the signal connection means for physically connecting to the sensing module 250 and the connecting pad 220 and electrically connecting to the card module chip 210, together with the signal connection pin 210b. That is, the signal connection pin 210b of the card module chip 210 is connected to the sensing module 250 provided on the connecting pad 220 through the signal connection groove 223 of the connecting pad 220. Accordingly, the card module chip 210 and the sensing module 250 are electrically connected with each other.

[0041] Next, an internal configuration of the card module chip 210 will be described with reference to FIG. 9. As shown in FIG. 9, the card module chip 210 includes a memory card 211 for storing biological signals which are detected from the electrode 240 and amplified in the sensing module 250, and whose noise is removed, and a power supply unit 212 for supplying power. As described in FIG. 6, the memory card 211 and the battery 212a are detachably inserted in the card module chip 210 through the slot 210c, the battery 212a inserted in the card module chip 210 is mounted on the power supply unit 212, and power is supplied to the sensing module 250 through a wire 252. The memory card 211 receives biological signals from the sensing module 250. The memory card 211 includes a memory unit 211a for storing measured digital biological signals, a communication unit 211c for transmitting the stored biological signals to the outside, and an internal control unit 211b for controlling storage and transmission in accordance with a control of the card module chip 210. The internal control unit 211b may compress or encrypt data. The communication unit 211c may include zigbee, Bluetooth, WiFi, or the like, as PAN. Accordingly, the biological signal data stored in the memory unit 211a may be transmitted by communicating with the communication modules 11b, 12b, and 13b of the analysis device 10 through the communication unit 211c as described above. Alternatively, the biological signal data may be transmitted in such a manner that the memory card 211 itself is pulled out from the module chip 210, and then is loaded which is inserted into the card slots 11a, 12a, and 13a of the analysis device 10.

[0042] Next, an internal configuration of the sensing module chip 250 will be described with reference to FIG. 10. As shown in FIG. 10, the sensing module chip 250 includes a sensing unit 255 for amplifying biological signals from the electrode 240 and removing noise, and a microcomputer unit 254 for controlling the sensing module chip 250 by processing the biological signals input from the sensing unit 255 and storing the processed signals in the memory card 211 of the card module chip 210. The microcomputer unit 254 includes

an AD converter **254a** for converting biological signals received through the sensing unit **255** from analog signals to digital signals, a data memory **254b** for storing the biological signals converted into the digital signals, and a program memory **254c** for storing a program controlling the card module chip **210**. Accordingly, analog biological signals received from the sensing unit **255** in accordance with a program stored in the program memory **254c** are converted into digital signals through the AD converter **254a**, stored in the data memory **254b**, transmitted to the memory card **211** of the card module chip **210**, and then stored in the memory unit **211a**.

[0043] The biological signal measuring apparatus described as above may be utilized as follows.

[0044] First, as shown in FIG. 5, a user attaches the biological signal measuring pad **200** to an appropriate body region when wishing to measure his own health status while carrying the biological signal measuring pad **200**. A variety of types of pads **200** used in ECG waveforms, EEG waveforms, EMG waveforms, pulse waveforms, a body temperature, a blood sugar, and the like, may be attached according to applications of the pad **200**. Here, a case in which a user attaches the pad **100** to his own wrist **1** to measure a pulse waveform is assumed. Obviously, in this instance, the memory card **211** for data storage and communication and the battery **212a** that is a power source should be mounted in the module chip **210**. Before attaching the pad **200** to the body, a conductive gel may be attached to the electrode **240**. In this manner, when attaching the pad **200** to the wrist **1**, analog biological signals such as pulse waveforms are measured through the electrode **240**, and the measured analog biological signals are transmitted to the sensing module chip **250** through the connecting pin **210a** connected with the electrode **240**. The analog signals transmitted into the module chip **250** are amplified in the sensing unit **255**, converted into digital signals in the AD converter **254a**, and then stored in the data memory **254b** and the memory unit **211a** of the memory card **211** of the card module chip **210**. In this state, when the user wishes to check analyzed results by immediately transmitting the measured biological signals to the analysis device **10**, data may be transmitted in such a manner that the communication unit **211c** is connected with the communication modules **11a**, **12a**, and **13a** of the analysis device **10** in a wireless manner. Although not shown in the drawings, a transmission button may be provided on one side of the card module chip **210**, and the internal control unit **211b** operates the communication unit **211c** to thereby initiate wireless communication when a corresponding button is pushed by a user. Alternatively, a user pulls the memory card **211** out from the module chip **210**, and directly mounts the memory card **211** in the analysis device **10** to thereby transmit data.

[0045] The analysis device **10** analyzes the transmitted biological signals, and informs diagnostic results suitable for the analyzed signals. When the pulse waveform measured by the user is in a normal range, the analysis device **10** informs a corresponding diagnostic result as normal, and when the pulse waveform is in an abnormal range such as bradycardia or pyknoardia, the analysis device **10** informs required measures such as recommending diagnosis of a corresponding health status and consultation with experts, or the like. Then, the user may well manage his health status by appropriately performing corresponding measures.

[0046] Therefore, by utilizing the detachable biological signal measuring pad and apparatus, a user may conveniently measure his own health status anytime and anywhere, and

communicate with the analysis device by loading the detachable memory card in the analysis device or using wireless communication, and therefore the measured results are rapidly utilized. As a result, rapid measuring and utilization of the biological signals are achieved to thereby realize a healthy society.

[0047] Meanwhile, in the biological signal measuring pad according to the second embodiment of the present invention, it should be noted that the memory card and the power supply unit may be attached and detached to and from the card module chip, and the sensing unit may be mounted in the sensing module chip. In this manner, when the sensing unit is mounted in separate module chips, a user may select a sensing unit having a sensing function with respect to his suspected disease. That is, the sensing unit may be manufactured so as to have only its own unique sensing function. Therefore, sizes of the card module chip and the sensing module chip may be reduced, and only one sensing function is driven to thereby reduce power consumption. By the reduction in size and power consumption, the detachable biological signal measuring pad according to the present invention may be more easily carried.

[0048] The present invention has been described with reference to the embodiments shown in the drawings, but this is merely an example, and it will be apparent to those skilled in the art that various modifications can be made to the above-described exemplary embodiments of the present invention without departing from the spirit or scope of the invention.

[0049] For example, in the present specification, the detachable biological signal measuring pad including two electrodes has been described. However, the present invention may be implemented in the detachable biological signal measuring pad having one or at least three electrodes. Each electrode may be used for different types of measuring biological signals.

[0050] In addition, in the present specification, an example in which the connecting means and the signal connection means are separately implemented has been described, but an integrated type of the connecting means and the signal connection means may be implemented. For example, the connecting means may include at least three wires, the electrode may be connected to the sensing module chip without being connected to the card module chip, and the power supply unit and the memory card of the card module chip may be connected only to the sensing module chip without being connected to the electrode.

[0051] In addition, in the present specification, an example in which the memory card is detachable has been described, but a built-in memory incapable of being attached and detached may be used instead of the memory card. In this case, the module chip may be directly connected to the analysis device to thereby transmit data from the built-in memory to the analysis device.

[0052] In addition, in the present specification, an example in which the electrode directly contacts the skin has been described, but a transducer for converting chemical or physical values into electrical signals may be provided between the electrode and the skin. The transducer may be electrically connected to the electrode, and fixed in the pad main body. As an example, the transducer may be a blood sugar sensor for transmitting electrical signals corresponding to blood sugar values to the electrode. In this case, the blood sugar sensor may include a microneedle array for forming a fine hole in the skin, and a blood sugar analysis unit for forming electrical

signals corresponding to a blood sugar value from blood transmitted through the microneedle array.

[0053] It will be apparent to those skilled in the art that various modifications can be made to the above-described exemplary embodiments of the present invention without departing from the spirit or scope of the invention. Thus, it is intended that the present invention covers all such modifications provided they come within the scope of the appended claims and their equivalents.

1-17. (canceled)

18. A detachable biological signal measuring pad comprising:

a pad main body for detachably adhering to a human body;

a biological signal detecting electrode provided on an adhesive surface of the main body adhering to the human body;

a card module chip provided on a surface opposite to the adhesive surface so as to be physically connected with the electrode, and the card module chip includes a memory card for storing the biological signals detected by the electrode, a power supply unit for supplying power mounted therein, and a first and second connecting pins protruding from the card module chip;

a connecting pad provided between the electrode of the main body and the card module chip includes a plug groove, wherein the first connecting pin penetrates the connecting pad through the plug groove to make direct electrical connection with the electrode and the plug groove; and

a sensing module provided on the connecting pad so as to be electrically connected with the plug groove, and the sensing module includes a sensing unit for sensing and amplifying the biological signals transmitted from the electrode;

wherein the first connecting pin is forcibly coupled to the electrode, and wherein the sensing module transmits amplified biological signals to the card module chip via the second connecting pin.

19. The detachable biological signal measuring pad of claim 18, wherein the memory card is detachably coupled to the card module chip.

20. The detachable biological signal measuring pad of claim 18, wherein the card module chip further includes a memory unit for storing the amplified biological signals, a communication unit for transmitting the stored biological signals to the outside, and an internal control unit for controlling storage and transmission in accordance with a control of the card module chip.

21. The detachable biological signal measuring pad of claim 18, wherein the sensing module further includes a microcomputer unit, the microcomputer unit controls the card module chip so as to process the biological signals provided by the sensing unit and store the processed biological signals.

22. The detachable biological signal measuring pad of claim 21, wherein the microcomputer unit includes an Analog to Digital converter for converting analog signals provided by the sensing unit into digital signals, a data memory for storing the biological signals converted into the digital signals, and a program memory for storing a program controlling the card module chip.

23. A biological signal measuring apparatus comprising:

a system-on-chip biological signal measuring pad including a card module chip in which a memory card is mounted; and

an analysis device receiving and analyzing the biological signals stored in the memory card,

wherein the system-on-chip biological signal measuring pad includes

a pad main body for detachably adhering to a human body;

a biological signal detecting electrode provided on an adhesive surface of the main body adhering to the human body;

a card module chip provided on a surface opposite to the adhesive surface so as to be physically connected with the electrode, and the card module chip includes a memory card for storing the biological signals detected by the electrode, a power supply unit for supplying power mounted therein, and a first and second connecting pins protruding from the card module chip;

a connecting pad provided between the electrode of the main body and the card module chip includes a plug groove, wherein the first connecting pin penetrates the connecting pad through the plug groove to make direct electrical connection with the electrode and the plug groove; and

a sensing module provided on the connecting pad so as to be electrically connected with the plug groove, and the sensing module includes a sensing unit for sensing and amplifying the biological signals transmitted from the electrode;

wherein the first connecting pin is forcibly coupled to the electrode, and wherein the sensing module transmits amplified biological signals to the card module chip via the second connecting pin.

\* \* \* \* \*

专利名称(译)	可拆卸的生物信号测量垫和使用该测量垫的生物信号测量装置		
公开(公告)号	<a href="#">US20150150506A1</a>	公开(公告)日	2015-06-04
申请号	US14/614468	申请日	2015-02-05
申请(专利权)人(译)	UMEDIX CORPORATION LIMITED		
当前申请(专利权)人(译)	UMEDIX CORPORATION LIMITED		
[标]发明人	WOO SUNG HUN		
发明人	WOO, SUNG HUN		
IPC分类号	A61B5/00		
CPC分类号	A61B5/6833 A61B5/7225 A61B5/0022 A61B5/0002 A61B5/01 A61B5/0205 A61B5/02055 A61B5/02438 A61B5/0245 A61B5/04 A61B5/04087 A61B5/0478 A61B5/0492 A61B5/14532 A61B5/7203		
优先权	PCT/KR2011/005437 2011-07-22 WO 13/810094 2013-01-14 US 1020100071180 2010-07-23 KR 1020100071181 2010-07-23 KR		
其他公开文献	US9192337		
外部链接	<a href="#">Espacenet</a> <a href="#">USPTO</a>		

摘要(译)

公开了一种可拆卸的生物信号测量垫，其测量诸如脉冲或体温的生物信号。生物信号测量垫包括可拆卸地粘附到主体的粘合垫主体，设置在粘附到主体的主体的粘合表面上的生物信号检测电极，以及包括安装在主体上的存储卡的模块芯片。其与电极连接并存储在电极中测量的生物信号，并设置在与粘合表面相对的表面上。

