



US 20150051455A1

(19) **United States**

(12) **Patent Application Publication**
Wasielewski et al.

(10) **Pub. No.: US 2015/0051455 A1**
(43) **Pub. Date: Feb. 19, 2015**

(54) **SMART JOINT IMPLANT SENSORS**

Publication Classification

(71) Applicant: **ZIMMER, INC.**, Warsaw, IN (US)

(51) **Int. Cl.**
A61B 5/00 (2006.01)
A61B 5/145 (2006.01)
A61B 5/01 (2006.01)

(72) Inventors: **Ray C. Wasielewski**, New Albany, OH (US); **Richard D. Komistek**, Knoxville, TN (US); **Mohamed R. Mahfouz**, Knoxville, TN (US)

(52) **U.S. Cl.**
CPC *A61B 5/4851* (2013.01); *A61B 5/01* (2013.01); *A61B 5/14507* (2013.01); *A61B 5/742* (2013.01); *A61B 5/0002* (2013.01)
USPC **600/301**; **600/587**

(21) Appl. No.: **14/530,915**

(57) **ABSTRACT**

(22) Filed: **Nov. 3, 2014**

A prosthesis for implantation into a mammalian body, the device comprising: (a) a prosthesis for implantation into a mammalian body that includes a sensor array comprising a plurality of sensors mounted to the prosthesis; and (b) an electronics structure for receiving signals from the sensor array and wirelessly transmitting representative signals to a remote receiver, where the plurality of sensors are operative to sense pressure, applied to the prosthesis by another object, in at least two axes generally perpendicular to one another.

Related U.S. Application Data

(63) Continuation of application No. 11/890,307, filed on Aug. 3, 2007.

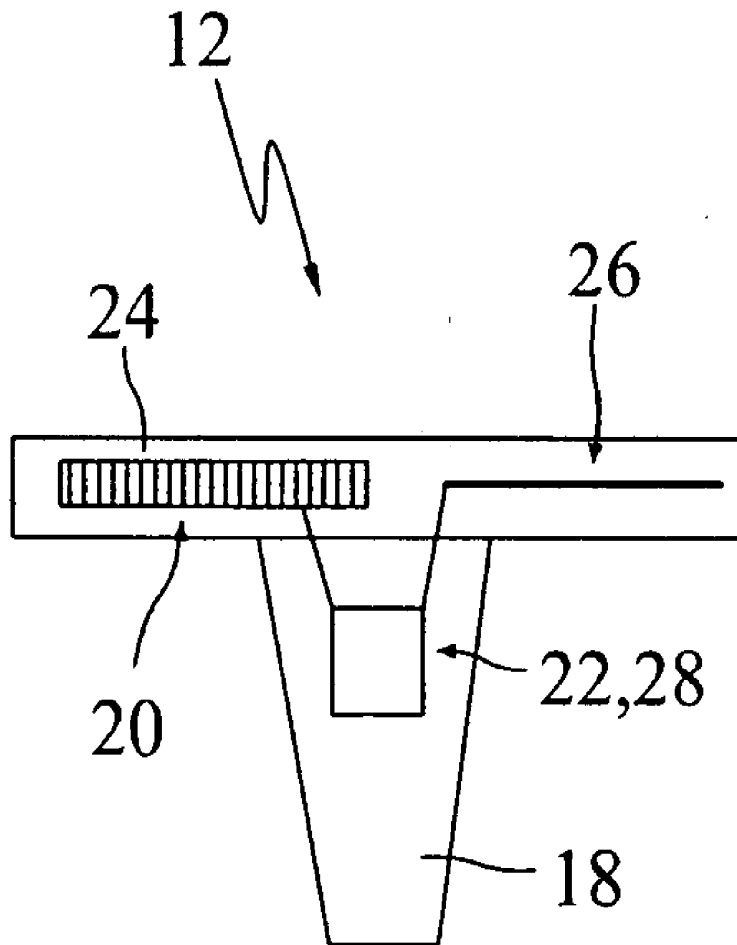

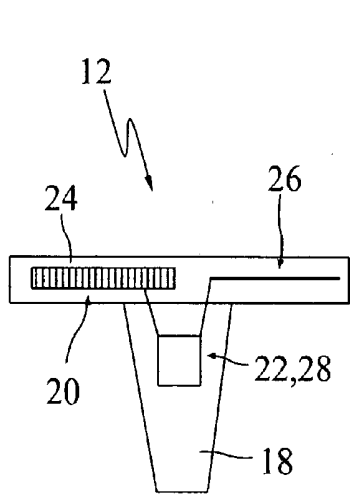

FIG. 1

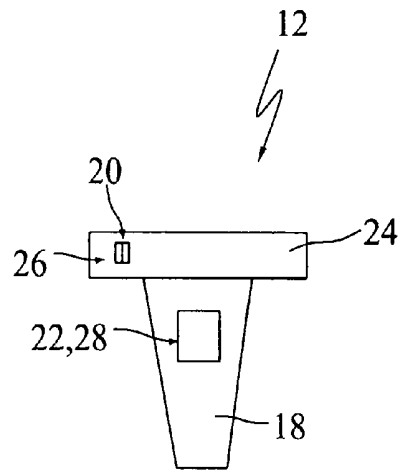

FIG. 2

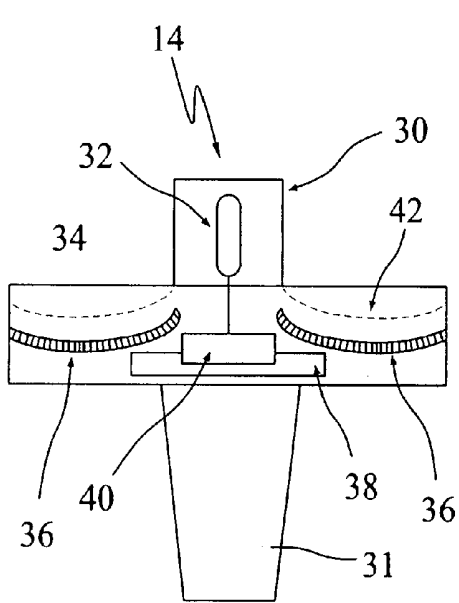

FIG. 3

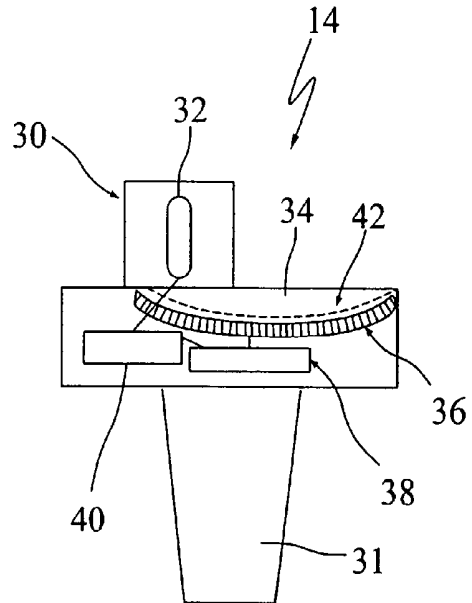

FIG. 4

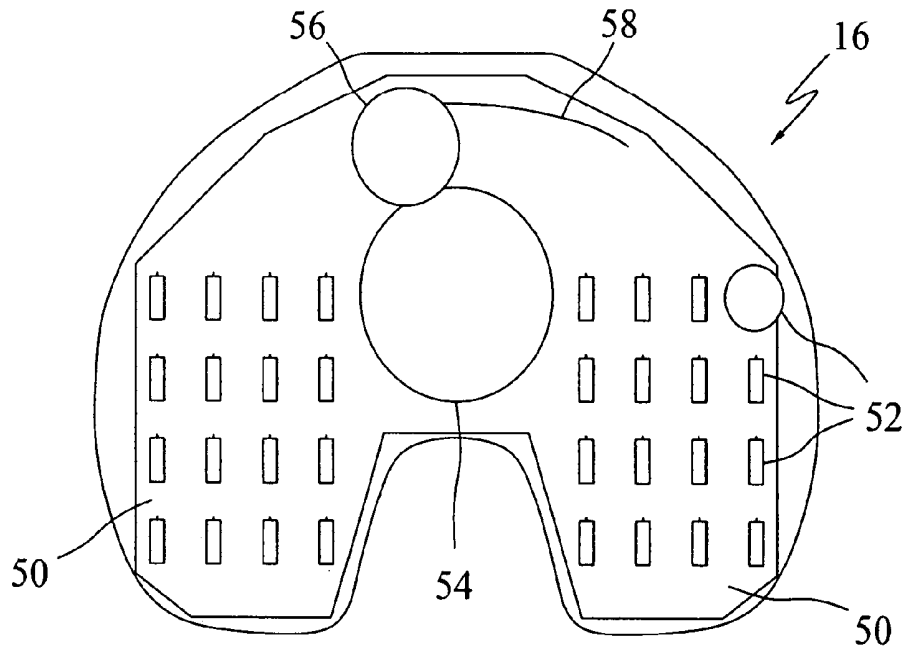

FIG. 5

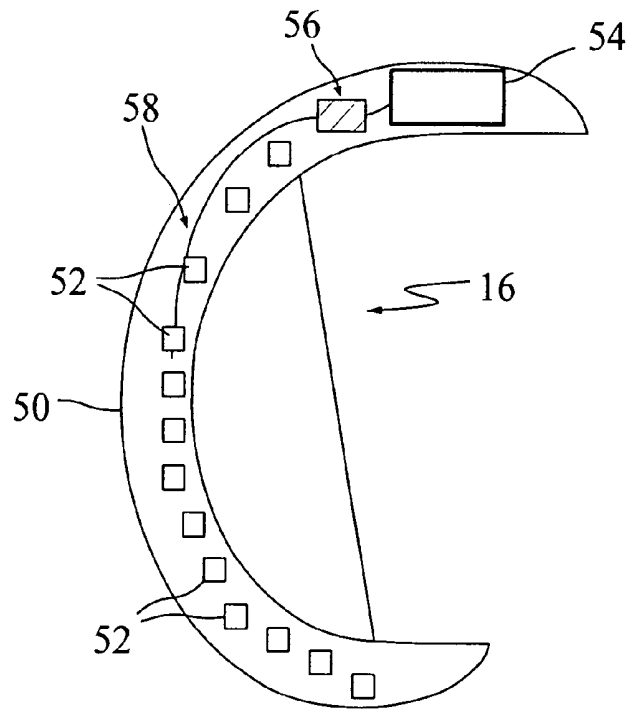

FIG. 6

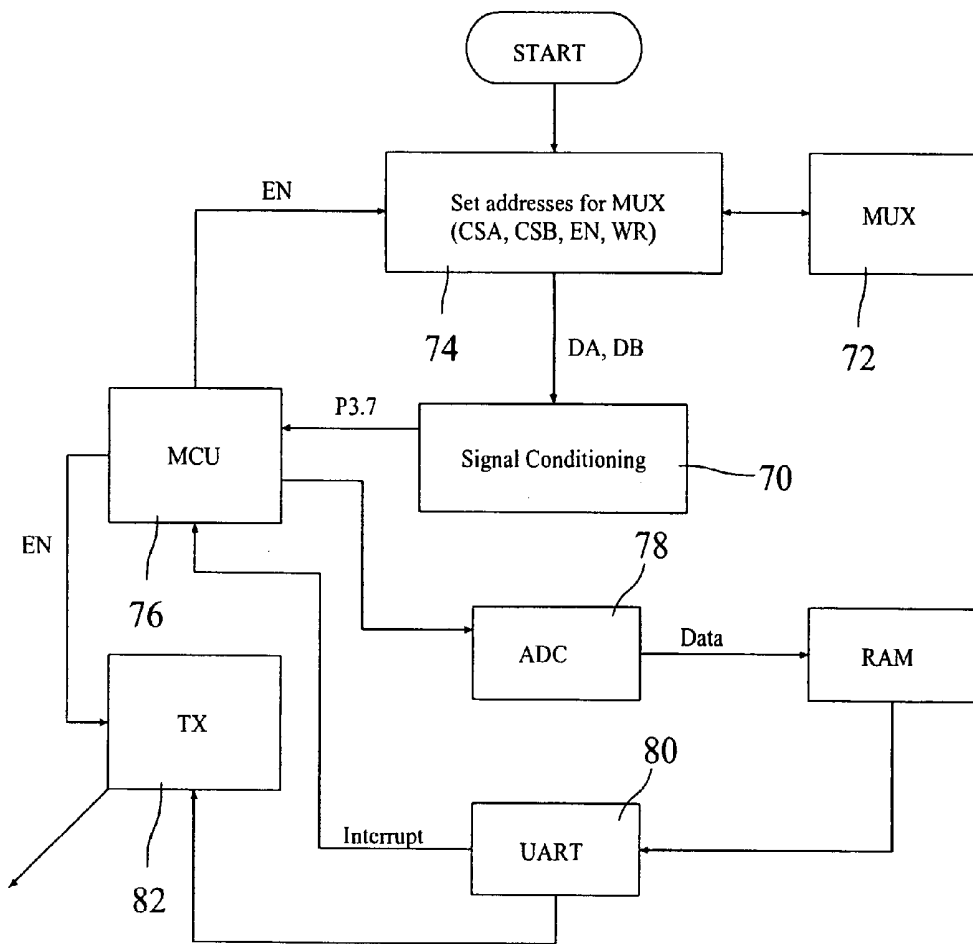

FIG. 7

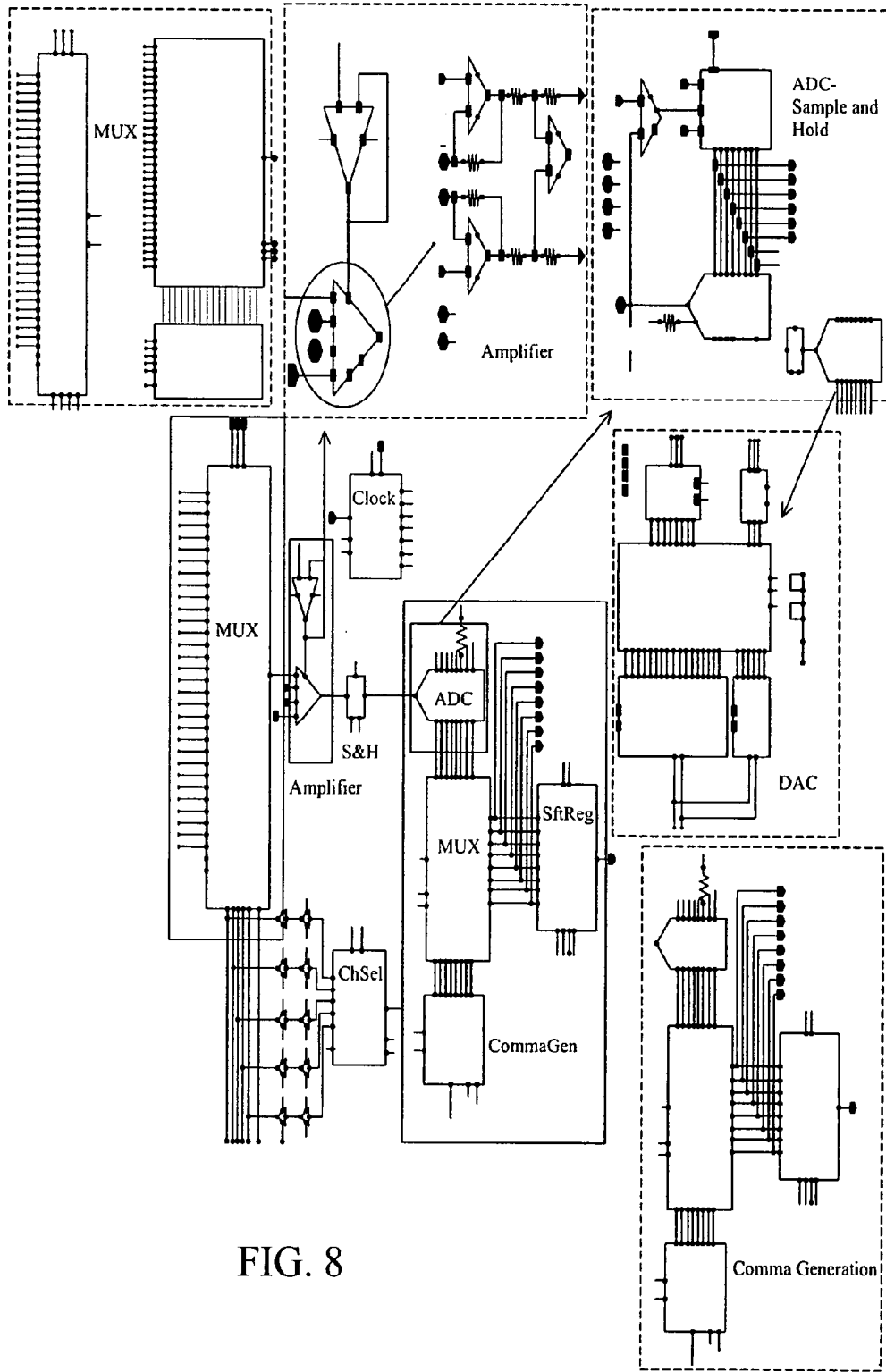

FIG. 8

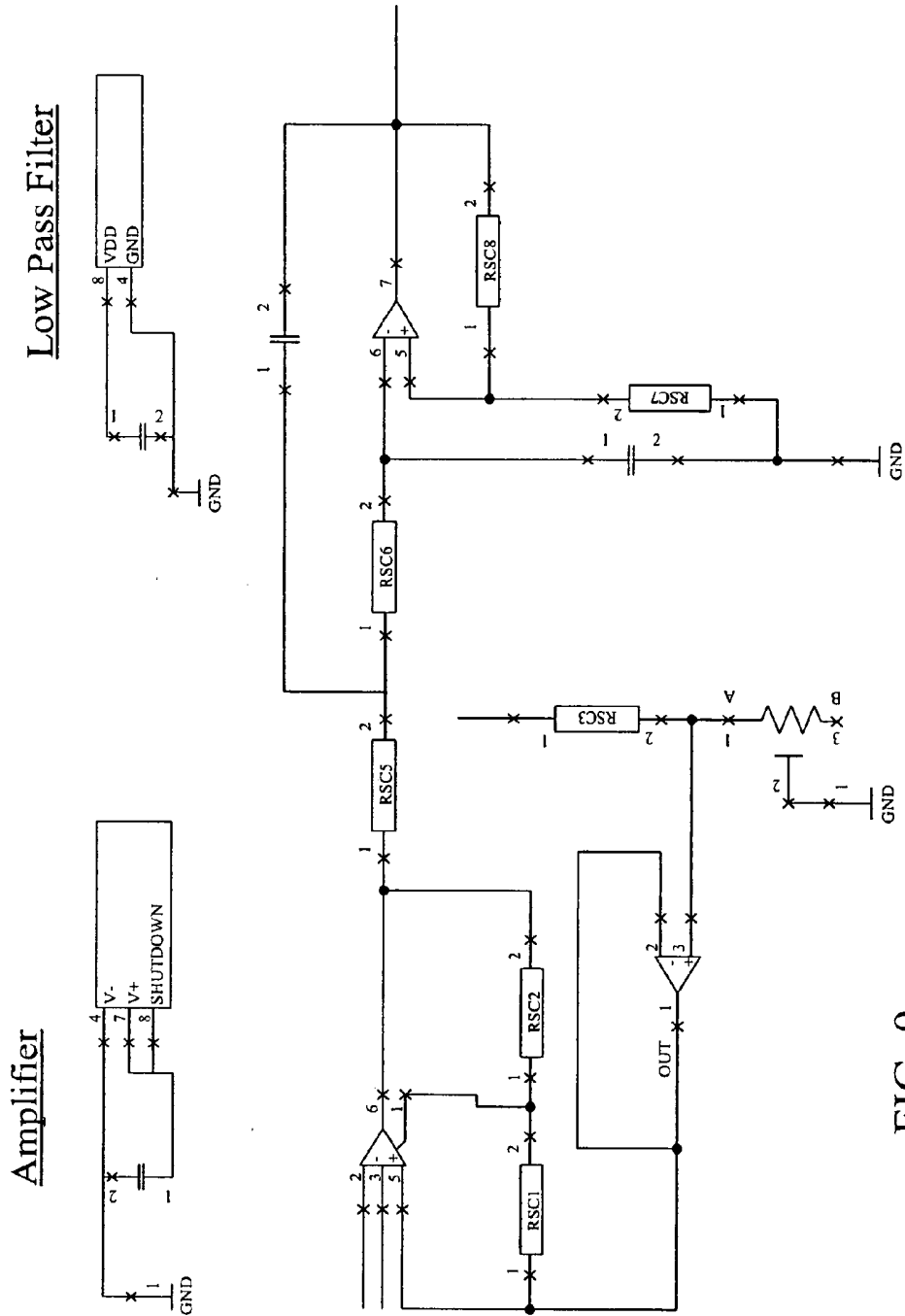

FIG. 9

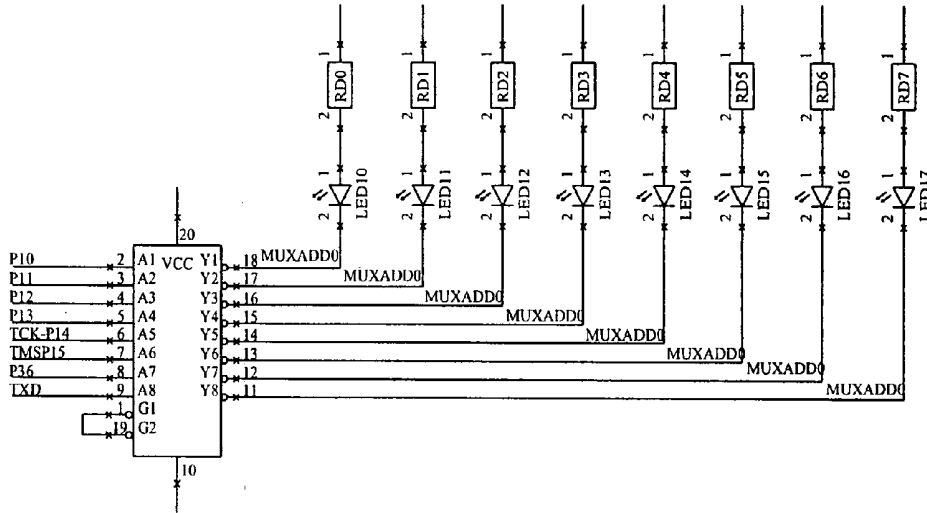

FIG. 10

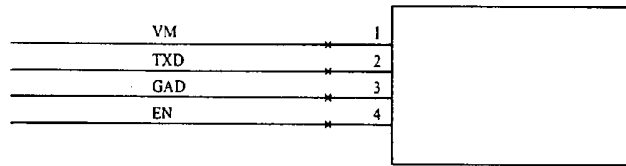

FIG. 11

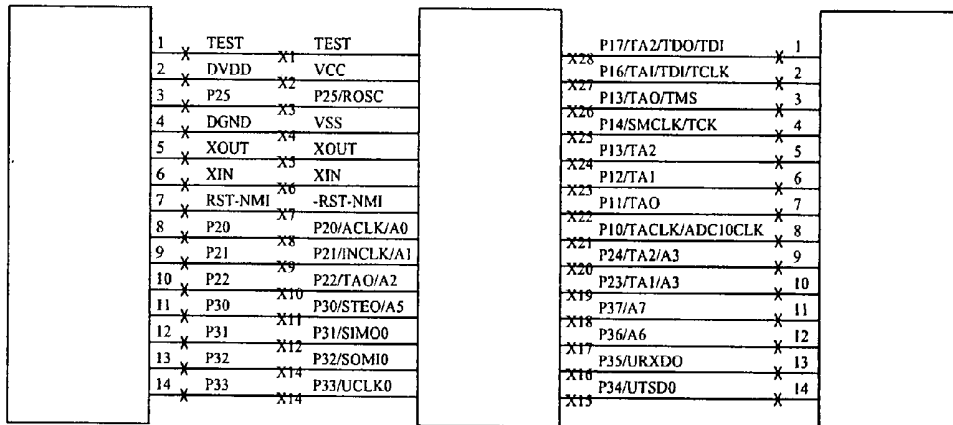

FIG. 12

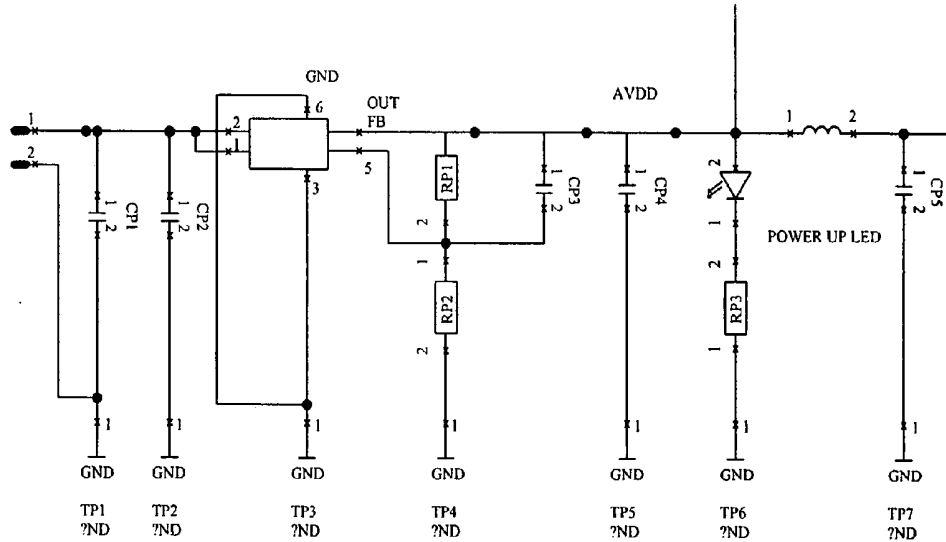

FIG. 13

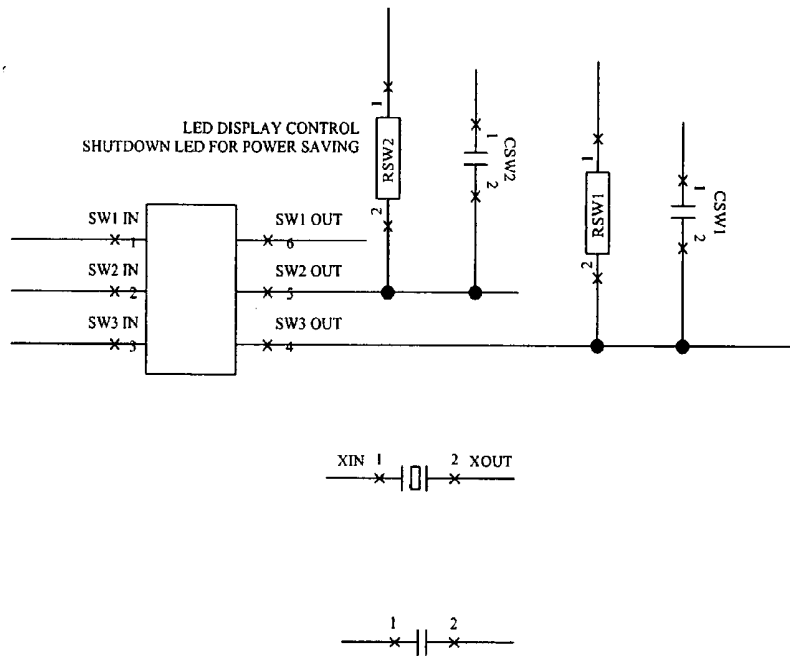

FIG. 14

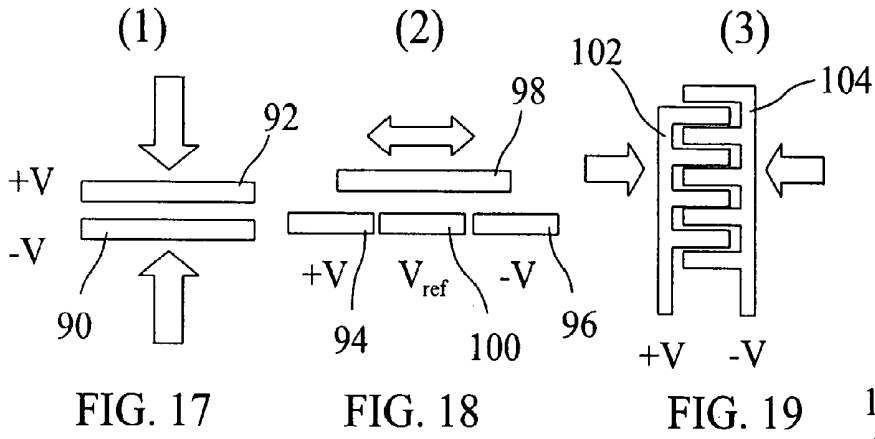

FIG. 17

FIG. 18

FIG. 19

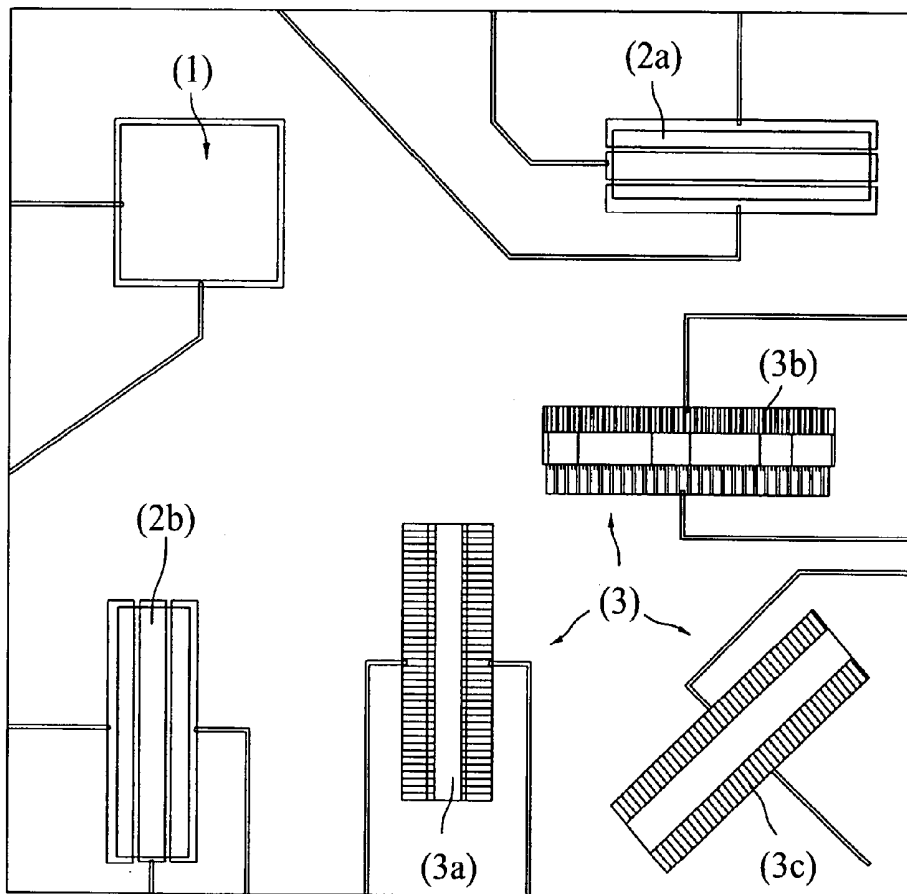

FIG. 20

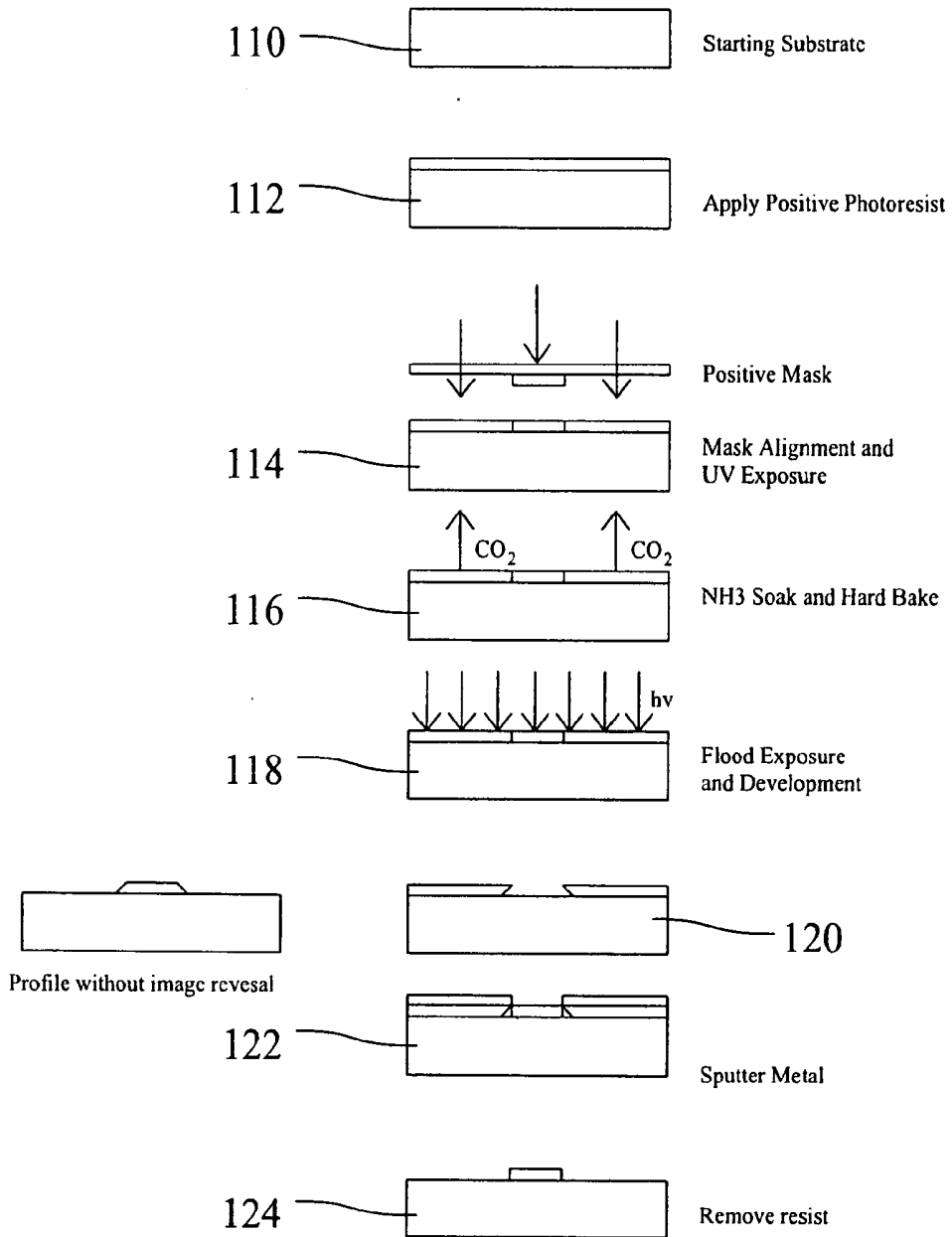

FIG. 21

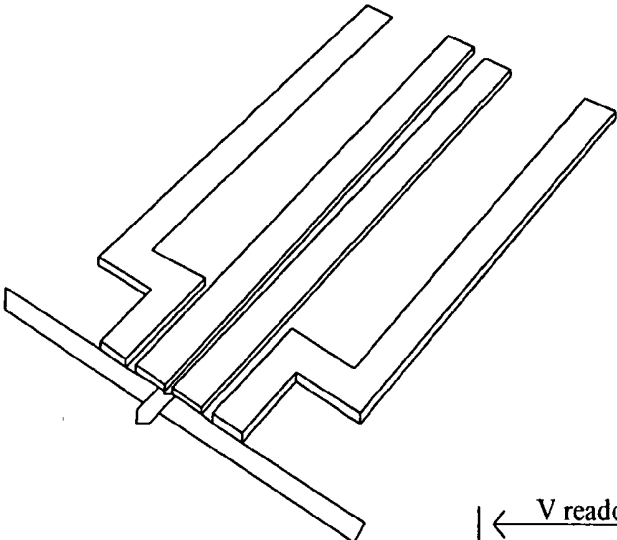

FIG. 22

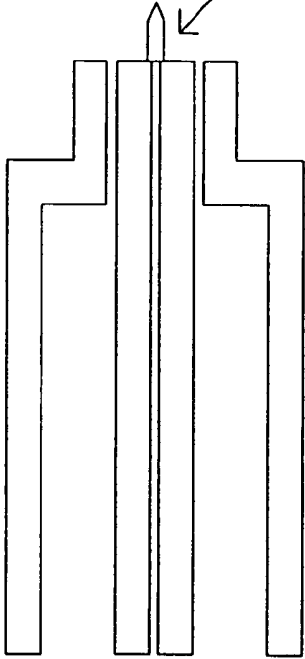
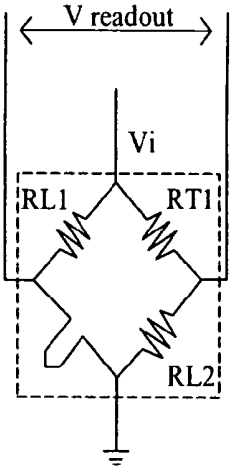

FIG. 23

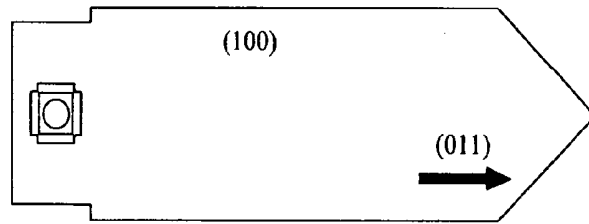

FIG. 24

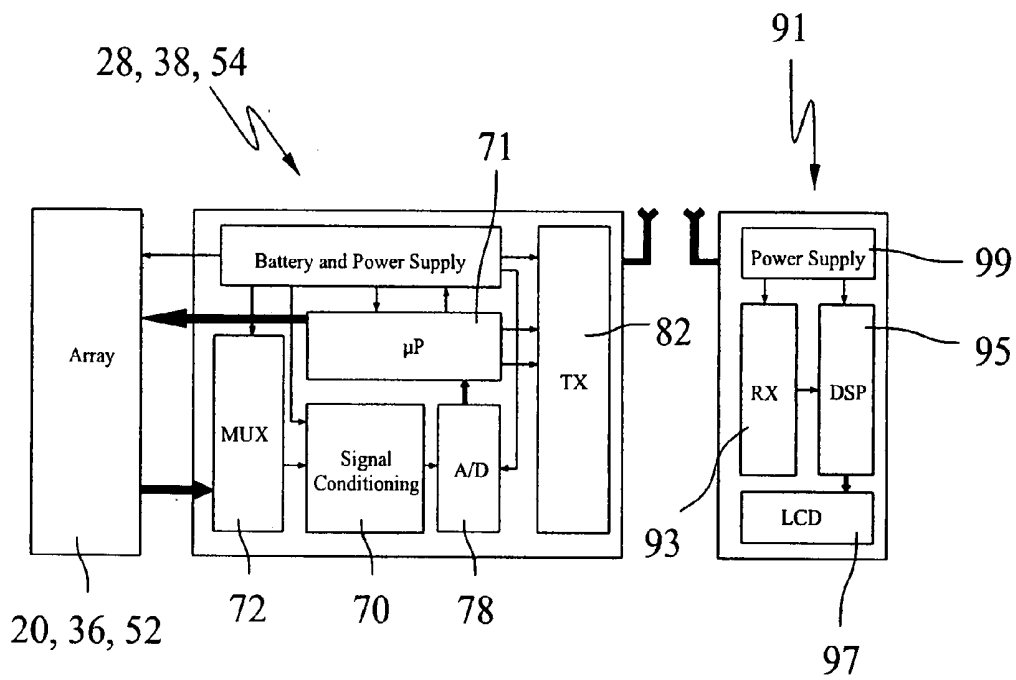

FIG. 25

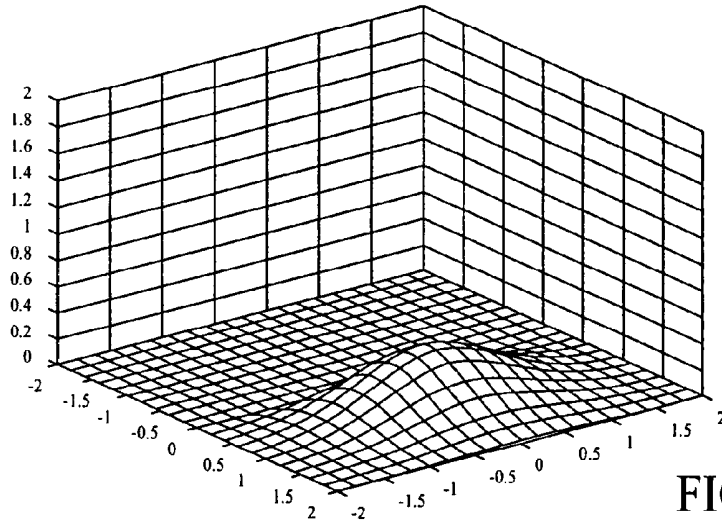

FIG. 26

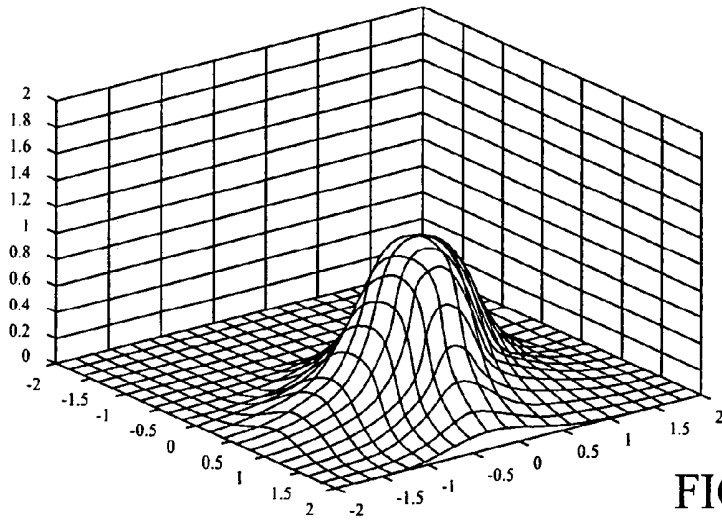

FIG. 27

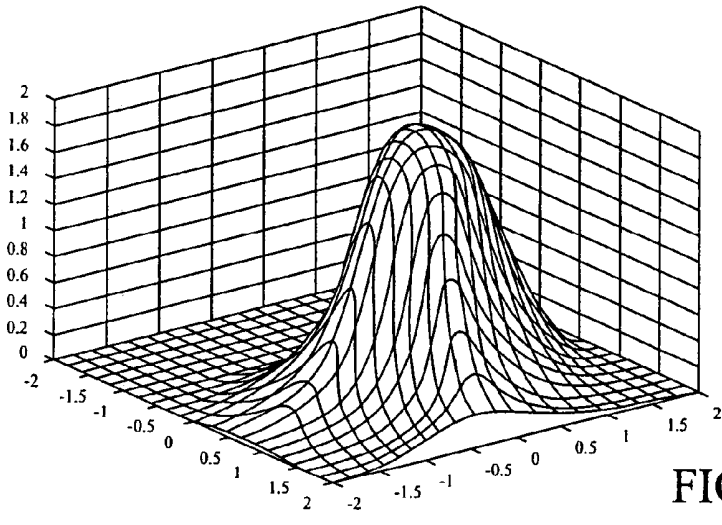
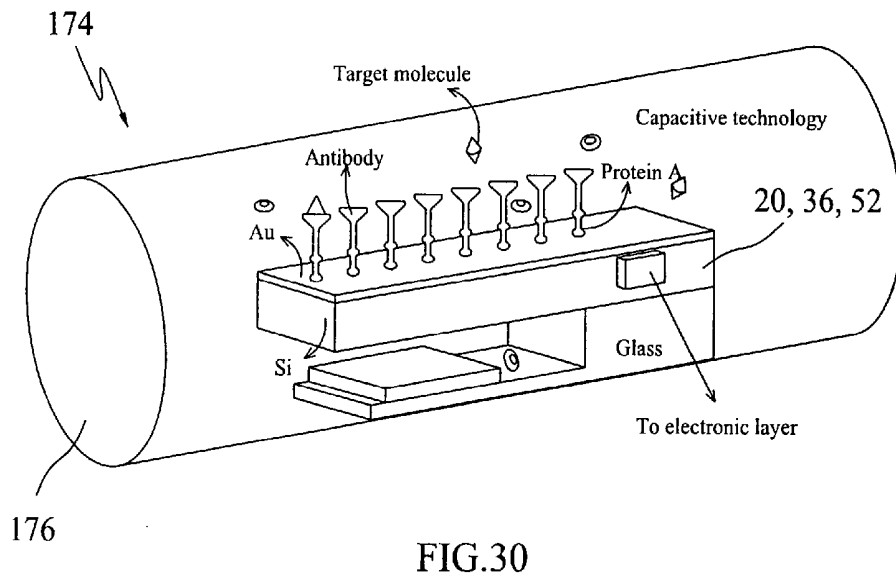
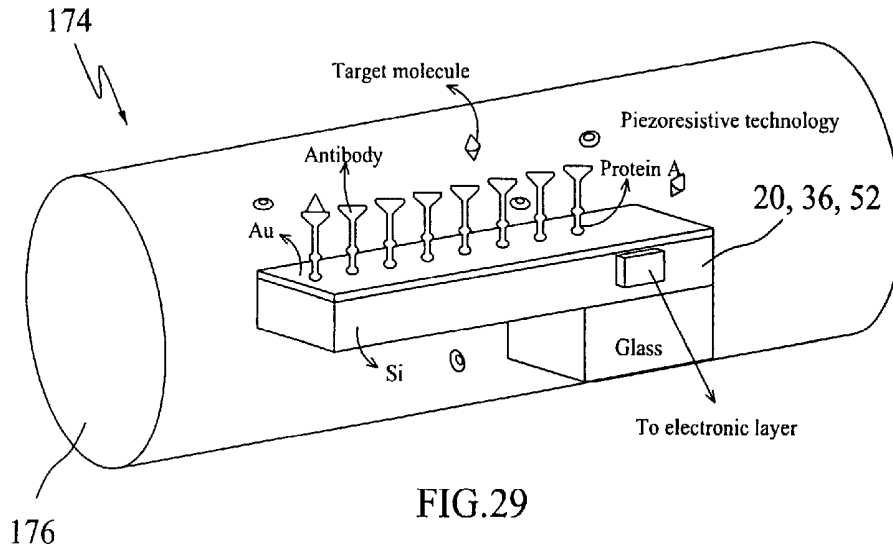

FIG. 28



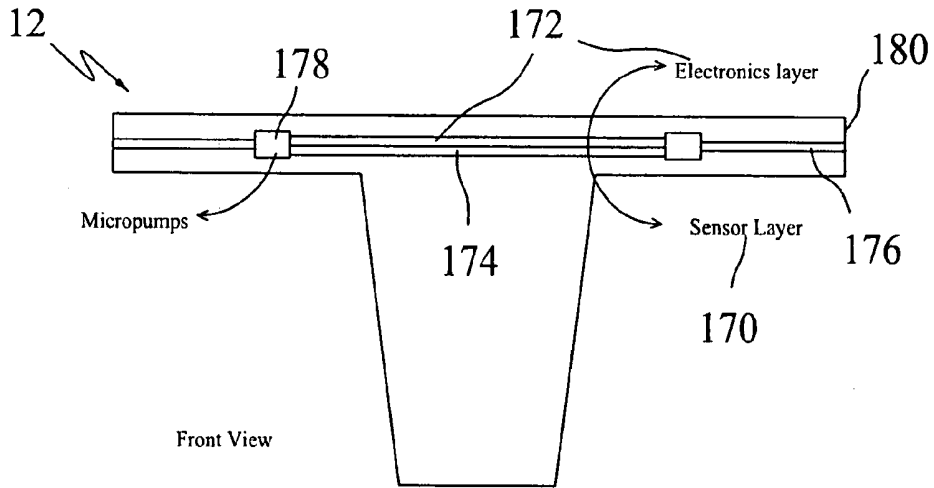

FIG. 31

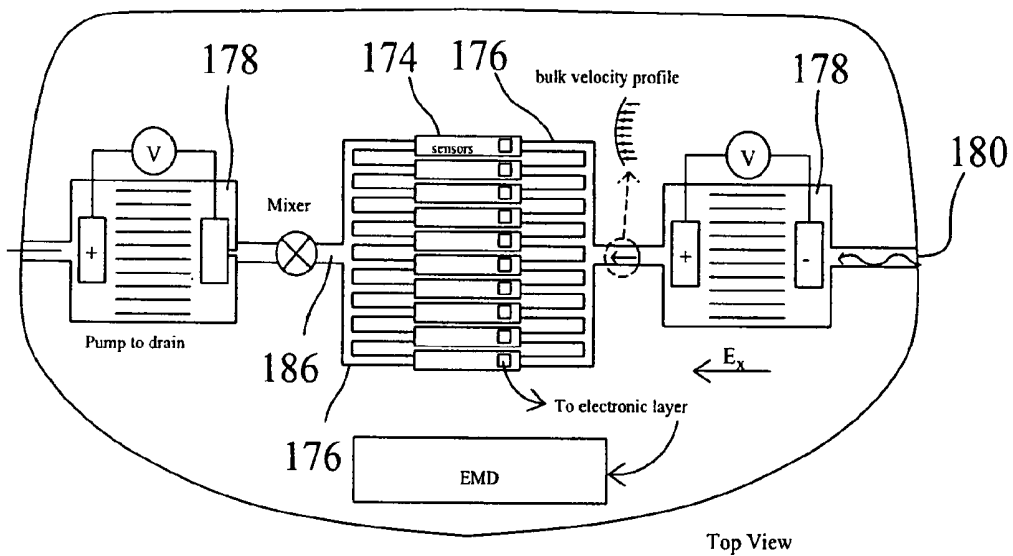

FIG. 32

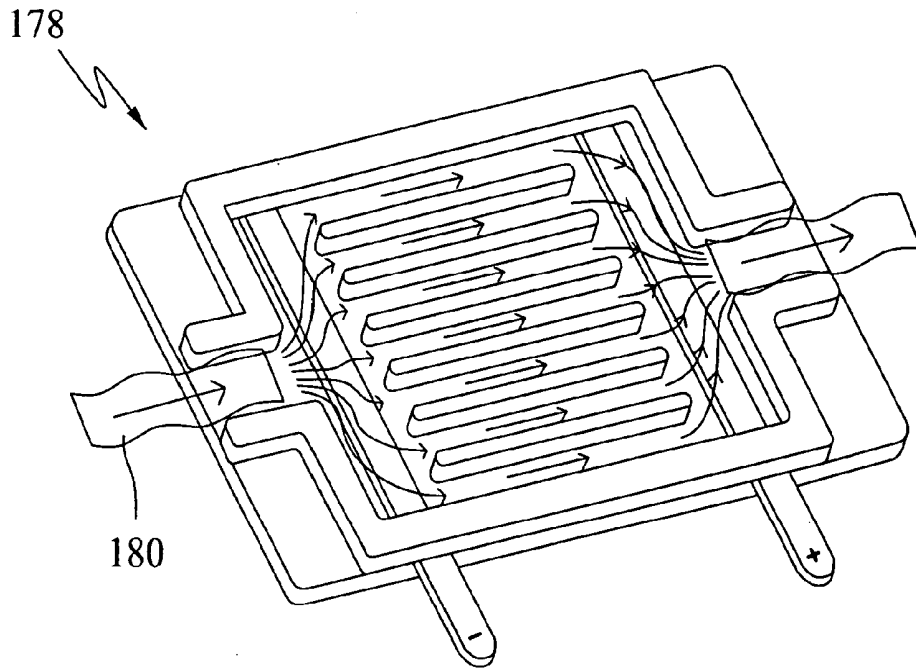

FIG. 33

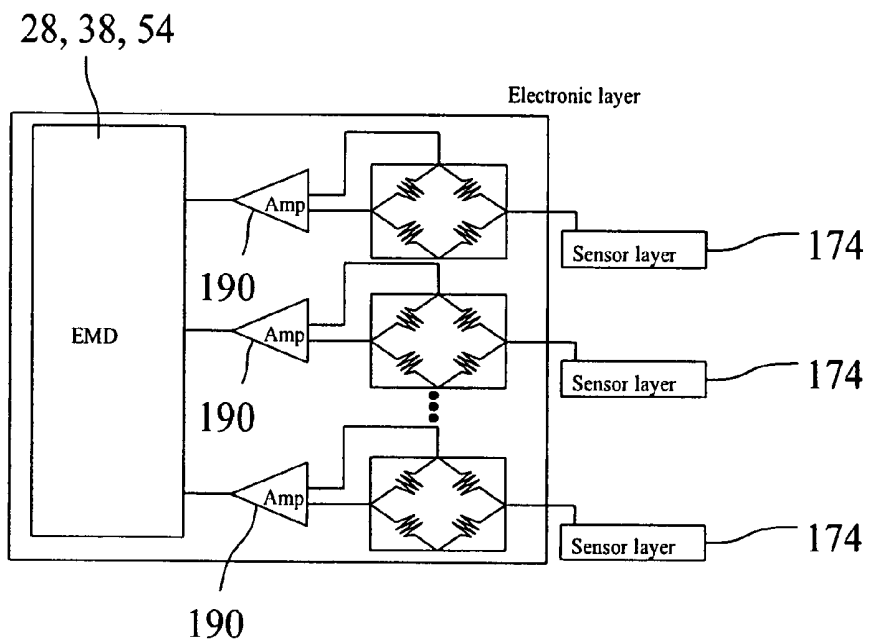

FIG. 34

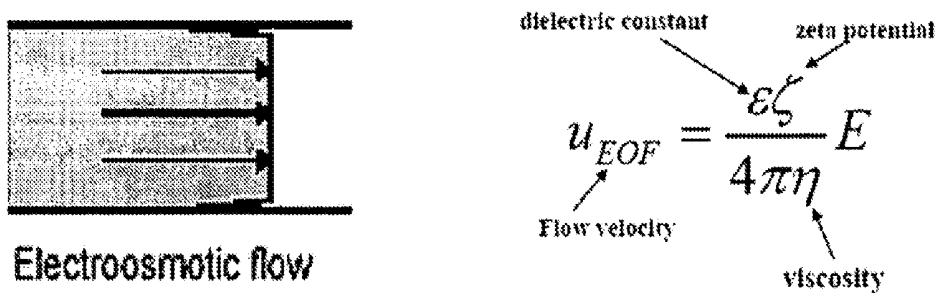

FIG. 35

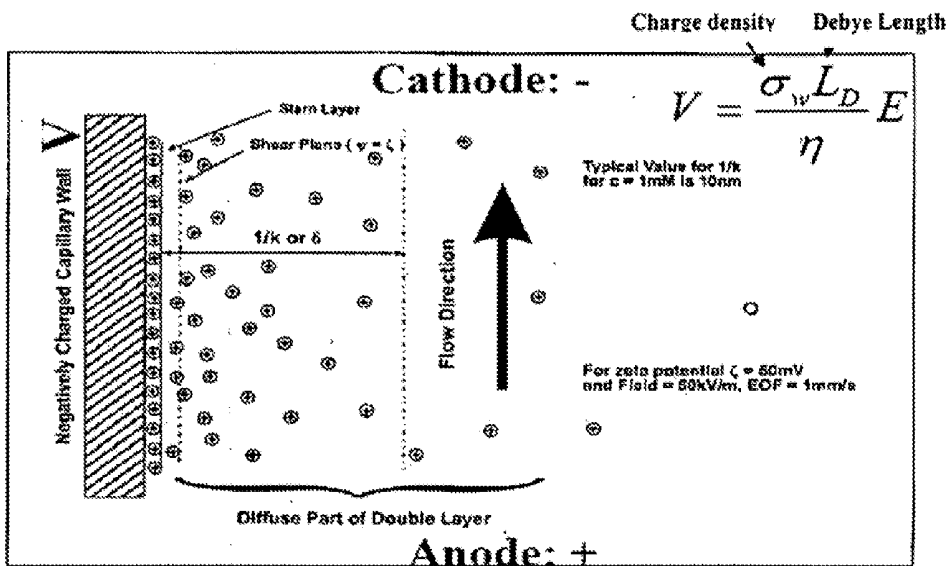

FIG. 36

SMART JOINT IMPLANT SENSORS

CROSS REFERENCE TO RELATED APPLICATIONS

[0001] This application is a continuation application of Ser. No. 11/890,307 filed on Aug. 3, 2007 that claims priority under 35 U.S.C. §120 of Patent Cooperation Treaty Application Serial No. PCT/US2006/005545 filed on Feb. 18, 2006, entitled "SMART JOINT IMPLANT INSERTS," which claimed priority under 35 U.S.C. §119 to U.S. Provisional Patent Application Ser. No. 60/654,650, filed Feb. 18, 2005, entitled "SURGICAL SMART INSERTS," the disclosure of which is hereby incorporated by reference.

RELATED ART

[0002] 1. Field of the Invention

[0003] The present invention is directed to sensors for utilization in the health care industry and, more specifically, to miniature sensors for use in prosthetic implants and prosthetic trials.

[0004] 2. Prospective of Related Art

[0005] Failure of total joint arthroplasty can be a rapid or insidious process. In cases of rapid failure, the diagnosis is often obvious, but unfortunately often too late to avoid surgical revision. Fortunately, most joint replacements simulate the joints of the body and slowly degrade over time for more subtle mechanical and biologic reasons. If a reliable detection method or system was operative to detect insidious or subtle failure and infection, these conditions can be mitigated or even reversed.

[0006] TJA failure etiologies can be divided generally into mechanical and biologic causes. The mechanical causes are generally wear of the articular surfaces and loosening of the prosthetic components. Abnormal loading conditions that are present immediately post-operatively or that worsen over time can directly affect the wear process. By the time these processes are apparent using conventional detection methods (e.g., linear wear on radiographs, implant-bone junction radiolucencies, and

osteolytic bone defects from excessive particulate wear debris) it is often too late for optimum implant survival to be achieved. By the time radiolucencies are seen between the various components and the bone, loosening has occurred and failure is eminent. Only early detection of these impending failures can allow for the possibility for simple or more conservative interventions to correct joint mechanical anomalies before becoming irreversible.

[0007] Biologic failure of the TJA can be attributable to inflammation or infection. Aseptic loosening can be seen as progressive radiolucencies on radiographs, but once again, too late for effective intervention. However, subtle changes in the synovial fluid might signal an insidious failure, thereby allowing non-operative intervention as opposed to complete revision surgery.

[0008] The markers for different failure modes of prosthetic implants are known. The following listing of references is indicative of the current knowledge regarding these markers. For example, increased pressure associated with the synovial fluid may be indicative of infection (see <http://www.kcom.edu/faculty/chamberlain/Website/lectures/tritizid/septarthrititis.htm> (septic arthritis)). In addition, it has been observed that synovial fluid having a low pH may be indicative of infection (see <http://www.kcom.edu/faculty/chamberlain/Website/lectures/tritizid/septarthrititis.htm> (septic arthritis)) (see also Tulamo R. M. et al., *Equine Vet. J.*, 1989 September; 21(5):325-31 (infectious arthritis, horse for pH below 6.9). The following references also acknowledge other markers indicative of infections: (1A) leukocyte (WBC) count is increased (see Trampuz A. et al., *Am. J. Med.*, 2004 Oct. 15; 117(8):556-62 (infected TKA); (1B) leukocyte (WBC) count is greater than or equal to 2500 per milliliter (see Mason J. B. et al., *J. Arthroplasty*, 2003 December; 18(8):1038-43 (revision TKA)); (2A) neutrophil (polymorphonuclear cells (PMNCs)) percentage is increased (see Trampuz A. et al., *Am. J. Med.*, 2004 Oct. 15; 117(8):556-62 (infected TKA)); (2B) neutrophil (polymorphonuclear cells (PMNCs)) percentage is greater than or equal to 60% (see Mason J. B. et al., *J. Arthroplasty*, 2003 December; 18(8):1038-43 (revision TKA)); (3) presence of bacterial deoxyribonucleic acid (detected by polymerase chain reaction) (see Mariani B. D. et al., *Clin. Orthop.*, 1996 October; (331):11-22),

[0009] Additional markers associated with synovial fluid that are indicative of infection include: (4) presence of antibodies (see <http://www.kcom.edu/faculty/chamberlain/Website/lectures/tritizid/septarthrititis.htm> (septic arthritis)); (5A) low glucose concentration (must compare to blood glucose level) (see Tulamo R. M. et al., *Equine Vet. J.*, 1989 September; 21(5):325-31 (infectious arthritis, horse)); (5B) low glucose concentration of less than 40 mg/dL (see <http://my.webmd.com/hw/arthritis/hw231503.asp>); (5C) low glucose concentration less than 0.6% (see <http://www.kcom.edu/faculty/chamberlain/Website/lectures/tritizid/septarthrititis.htm> (septic arthritis)); (6A) elevated protein level (see Tulamo R. M. et al., *Equine Vet. J.*, 1989 September; 21(5):325-31 (infectious arthritis, horse)); (6B) elevated protein level greater than or equal to 3 g/dL (see <http://my.webmd.com/hw/arthritis/hw231503.asp>); (7) higher concentration of excitatory amino acids (EAA) glutamate and aspartate (also related to arthritis) (see McNearney T. et al., *J. Rheumatol.*, 2000 March; 27(3):739-45); (8a) elevated level of lactate dehydrogenase (when blood levels of LDH are normal) (see Tulamo R. M. et al., *Equine Vet. J.*, 1989 September, 21(5):325-31. (infectious arthritis, horse); (8b) elevated level of lactate dehydrogenase (when blood levels of LDH are normal) greater than 333 IU/L (see <http://my.webmd.com/hw/arthritis/hw231503.asp>); and (9) white cell gene expression (see Deirmengian C., *Clin. Orthop. Related Res.*, November 2005; 440:38-40),

[0010] Those of ordinary skill are familiar with other markers such as, without limitation, lower viscosity of the synovial fluid (see Mazzucco D. et al., *J. Orthop. Res.*, 2002 November; 20(6):1157-63) and lower hyaluronic acid (HA) content (see Mazzucco D. et al., *Biomaterials*, 2004 August; 25(18):4433-45) signifying a failing or failed TKA. Other markers, such as, without limitation, the presence of uric acid crystals (monosodium urate monohydrate crystals) (see Ryckman C. et al., *Arthritis Rheum.*, 2003 August; 48(8):2310-20), the presence of calcium pyrophosphate crystals indicates pseudogout (see <http://my.webmd.com/hw/arthritis/hw231503.asp>), elevated leukocyte count (see Canoso J. J. et al., *Arthritis Rheum.*, 1979 December; 22(12):1361-4), elevated level of lactate dehydrogenase (when blood levels of LDH are normal) greater than 333 IU/L (see <http://my.webmd.com/hw/arthritis/hw231503.asp>), elevated MMP-9 (gelatinase-B) antigen levels (see Hsieh M. S. et al., *J. Cell. Biochem.*, 2003 Jul. 1; 89(4):791-0), and high concentrations

of S100A8/A9 (see Ryckman C. et al., *Arthritis Rheum.*, 2003 August; 48(8):2310-20) may be indicative of gout.

[0011] Further markers of synovial fluid indicative of arthritic patients include, without limitation, (1) lower concentration, elasticity and viscosity (see Fukuda K., *Clin. Calcium*, 2004 July; 14(7):103-7. (elasticity and viscosity); Mazucco D. et al., *J. Orthop. Res.*, 2002 November; 20(6):1157-63; Moskowitz R. W. et al., *Am. J. Orthop.*, 2004 February; 33(2 Suppl):5-9; Adams M. E. et al., *Drug Saf.*, 2000 August; 23(2): 115-30 (Hyaluronan smaller in size (OA)); Adams M. E. et al., *Drug Saf.*, 2000 August; 23(2):115-30 (Lower concentration of hyaluronan)); (2) higher cell count (see Fawthrop F. et al., *Br. J. Rheumatol.*, 1985 February; 24(1):61-9; Dieppe P. A. et al., *Arthritis Rheum.*, 1988 July; 31(7):882-90); (3) the presence of C reactive protein (CRP) (see Rowe I. F. et al., *Ann. Rheum. Dis.*, 1987 October; 46(10):721-6); (4) higher concentration of amino acids (see McNearney T. et al., *J. Rheumatol.*, 2000 March; 27(3):739-45); (5) higher concentration of excitatory amino acids (EAA) glutamate and aspartate (McNearney T. et al., *J. Rheumatol.*, 2000 March; 27(3):739-45); (6) presence of rheumatoid factor (RA) (see Sari L. et al., *Rev. Med. Chil.*, 1993 December; 121(12): 1374-81) (7) elevated IgE rheumatoid factor activity (RA) (see Gruber et al., *Clin. Exp. Immunol.*, 1988 February; 71(2):289-94); (8) higher beta-glucuronidase content (OA) (see Fawthrop F. et al., *Br. J. Rheumatol.*, 1985 February; 24(1):61-9); (9) increased nerve growth factor (NGF) concentration (see Halliday D. A. et al., *Neurochem. Res.*, 1998 June; 23(6):919-22); (10) higher levels of insulin-like growth factor 1 (IGF-1) and its binding proteins (IGFBP) 3 and 4 (in inflammatory joints) (see Kanety H. et al., *J. Rheumatol.*, 1996 May; 23(5):815-8); (11) higher Caeruloplasmin (Cp) concentration (RA and psoriatic arthritis) (see Dixon J. S. et al., *Rheumatol Int.*, 1988; 8(1): 11-4); (12) elevated oxidase activity (RA and psoriatic arthritis) (see Dixon J. S. et al., *Rheumatol Int.*, 1988; 8(1):11-4); and, (13) presence of polyamine oxidases (PAO) (RA) (see Ferrante A. et al., *Clin. Exp. Immunol.*, 1990 June; 80(3):373-5).

[0012] Some methods do exist for the detection of failing implants, but often are too late to positively impact treatment. Synovial fluid can be withdrawn from the joint at yearly follow-up, but with an increased risk of causing infection. Labs can be taken each year, but these labs show systemic effects that often occur only after extensive joint damage, where the systemic effects may not necessarily be specific to the joint.

[0013] Thus, there is a need in the art for a non-invasive system and associated method to test for these markers in vivo with the ability to transmit the test/detection data externally to an electronic data storage device during physician follow-ups signals to the patient that the conditions are abnormal, such as a prosthesis vibrating or otherwise objectively signaling to the patient.

INTRODUCTION TO THE INVENTION

[0014] The present invention is directed to sensors for utilization in the health care industry and, more specifically, to miniature sensors for use in prosthetic implants and prosthetic trials. The present invention encompasses intelligent implants incorporating sensors operative to measure different mechanical and biologic markers for prosthetic failure. Additionally, the sensors of the present invention are operative to monitor the distributed forces at such joints as the femorotibial and patellofemoral joints, providing a comparison

with both post-op and the established norms. A properly balanced knee is neither too loose, nor too tight, and will be reflected from the output from the sensors in the medial and lateral compartments transmitting signals indicative of appropriate joint pressure.

[0015] The invention may include a series of microsensing elements ("array") and a micropump fabricated using semiconductor or MEMS (microelectromechanical systems) fabrication technology. The sensors may be arranged in an array of sensing elements that are externally powered by either electromagnetic induction or radio frequency (RF) induction or internally powered using a battery or other power storage device. Data representative of that generated by the sensors is remotely transmitted using RF technology or other alternate technology known to those of ordinary skill or arising hereafter, thereby obviating any reliance on continuous wire-based communication from the sensors to the eventual output device. Pressure sensing elements, temperature sensing elements, and chemical sensing elements may be included in each sensor array in order to provide a more complete picture for an attending physician during, and subsequent to, surgery. For example, the aforementioned elements or other elements are operative to generate data indicative of the presence of infection and the pressure exerted upon one or more predetermined surfaces of a prosthetic implant.

[0016] There are numerous possible applications for the present invention. For starters, the present invention is applicable to prosthetic surgeries involving joint replacement. It is to be understood that the present invention is not limited to joint replacement surgeries, and may be easily modified to impart the desired functionality for any operational endeavor or any external fixation device such as a smart brace. The exemplary disclosure as recited herein is also applicable to prosthetic trial components, thereby giving the surgeon substantially real-time information about pressure distributions prior to fitting the eventual implanted prosthesis. As a breakthrough technology, the present invention allows unparalleled synergy between previously unrelated fields such as biology and microelectronics to enable monitoring of conditions not previously monitorable without the associated risk of infection or other complications.

[0017] In exemplary form, the present invention includes a sensor array, associated with a prosthetic implant, that is operative to detect at least one of: viscosity of the synovial fluid; pH of the synovial fluid; cell count within the synovial fluid; protein within the synovial fluid; phospholipids within the synovial fluid; hyaluronic acid within the synovial fluid; leukocytes within the synovial fluid; neutrophils within the synovial fluid; bacterial deoxyribonucleic acid within the synovial fluid; antibodies within the synovial fluid; glucose concentration within the synovial fluid; lactate dehydrogenase (LDH) within the synovial fluid; uric acid crystals within the synovial fluid; MMP-9 antigens (gelatinase-B) within the synovial fluid; nerve growth factor within the synovial fluid; excitatory amino acids (EAA) glutamate and aspartate within the synovial fluid; insulin-like growth factor 1 (IGF-1) and its binding proteins (IGFBP) 3 and 4 within the synovial fluid; oxidase activity within the synovial fluid; polyamine oxidases within the synovial fluid; caeruloplasmin (Cp) concentration within the synovial fluid; beta-glucuronidase content within the synovial fluid; S100A8/A9 within the synovial fluid; C reactive protein within the synovial fluid; rheumatoid factor within the synovial fluid; C3 and C4 within the synovial fluid; metal particulate within the synovial fluid; poly-

ethylene particulate within the synovial fluid; bone particulate within the synovial fluid; cement particulate within the synovial fluid; osteolytic enzymes within the synovial fluid; genetic markers within the synovial fluid; antibody markers within the synovial fluid; temperature of the synovial fluid; specific gravity of the synovial fluid; and white cells (and differential cell type) within the synovial fluid. The sensed condition is routed through a wireless transmitter and broadcast to a remote terminal. In a further exemplary embodiment, the sensor array and transmitter are integrated into a prosthetic device and subsequent to surgery, housed completely within the mammalian body. The data attributable to the sensor array is received by a remote terminal, which in exemplary form comprises a personal data assistant. A warning sign of early infection detection could be configured to correspond to a predetermined sound, a predetermined frequency, or other signal.

[0018] The present invention is applicable outside of the summary examples recited above and reference is had to the remainder of the written description to more fully understand the scope and spirit of the present invention.

[0019] It is a first aspect of the present invention to provide a prosthesis for implantation into a mammalian body, the device comprising: (a) a prosthesis for implantation into a mammalian body that includes a sensor array comprising a plurality of sensors mounted to the prosthesis; and (b) an electronics structure for receiving signals from the sensor array and wirelessly transmitting representative signals to a remote receiver.

[0020] In a more detailed embodiment of the first aspect, the sensor array includes sensors detecting at least one of a predetermined component, a predetermined contaminant, and a predetermined property. In yet another more detailed embodiment, the plurality of sensors include at least one of an encapsulated sensor and a sensor in fluid communication with mammalian bodily fluids bathing the prosthesis. In a further detailed embodiment, the electronics structure includes a timing circuit configured to automatically activate the sensor array and to automatically deactivate the sensor array. In still a further detailed embodiment, the plurality of sensors include at least one of resistive microcantilevers, piezoelectric microcantilevers, and microcapacitor sensors. In a more detailed embodiment, the prosthesis includes at least one of a knee replacement femoral prosthesis, a knee replacement tibial prosthesis, a knee replacement tibial tray prosthesis, a hip replacement femoral prosthesis, a hip replacement acetabular cup prosthesis, a hip replacement acetabular cup insert prosthesis, a trial knee replacement femoral prosthesis, a trial knee replacement tibial prosthesis, a trial knee replacement tibial tray prosthesis, a trial hip replacement femoral prosthesis, a trial hip replacement acetabular cup prosthesis, and a trial hip replacement acetabular cup insert prosthesis. In a more detailed embodiment, the prosthesis includes a knee replacement femoral prosthesis and the sensor array is embedded within the knee replacement femoral prosthesis. In another more detailed embodiment, the prosthesis includes a knee replacement tibial prosthesis and the sensor array is embedded within the knee replacement tibia prosthesis. In yet another more detailed embodiment, the prosthesis includes a knee replacement tibial tray prosthesis and the sensor array is embedded within the knee replacement tibial tray prosthesis. In still another more detailed embodiment, the prosthesis

includes a hip replacement femoral prosthesis and the sensor array is embedded within the hip replacement femoral prosthesis.

[0021] In yet another more detailed embodiment of the first aspect, the prosthesis includes a hip replacement acetabular cup prosthesis and the sensor array is embedded within the hip replacement acetabular cup prosthesis. In still another more detailed embodiment, the prosthesis includes a hip replacement acetabular cup insert prosthesis and the sensor array is embedded within the hip replacement acetabular cup insert prosthesis. In a further detailed embodiment, at least one of the plurality of sensors of the sensor array is operative to sense at least one of: leukocyte concentration, neutrophil concentration, bacterial deoxyribonucleic acid concentration, antibody concentration, glucose concentration, excitatory amino acids concentration, lactate dehydrogenase concentration, hyaluronic acid concentration, uric acid concentration, calcium pyrophosphate concentration, beta-glucuronidase concentration, nerve growth factor concentration, insulin-like growth factor concentration, Caeruloplasmin concentration, and oxidase concentration. In still a further detailed embodiment, at least one of the sensor array and the electronics structure is powered using at least one of electromagnetic induction, radio frequency induction, and battery power. In a more detailed embodiment, the electronics structure includes a microcontroller and a transmitter. In a more detailed embodiment, the electronics structure includes an application specific integrated circuit, which includes a filter for filtering out low frequency noise. In another more detailed embodiment, the electronics structure includes an application specific integrated circuit, which includes an amplifier for amplifying signals from the sensor array. In yet another more detailed embodiment, the electronics structure includes an application specific integrated circuit, which includes a multiplexer for multiplexing signals from the sensor array.

[0022] In yet another more detailed embodiment of the first aspect, the electronics structure includes an application specific integrated circuit, which includes an analog-to-digital converter for converting analog signals from the sensor array to digital signals. In still another more detailed embodiment, the electronics structure includes an application specific integrated circuit, which includes a processor for processing signals from the sensor array. In a further detailed embodiment, the sensors of the sensor array are operative to sense at least one of pressure and temperature. In still a further detailed embodiment, the prosthesis includes a microchannel and a micropump in communication with the microchannel to pump mammalian bodily fluid bathing the joint through the microchannel, where an interior of the microchannel is in communication with at least one of the plurality of sensors. In a more detailed embodiment, the wireless transmission of representative signals is accomplished using a radio frequency transmitter. In a more detailed embodiment, the plurality of sensors are operative to sense pressure changes in three axes of movement.

[0023] It is a second aspect of the present invention to provide a method of monitoring a prosthetic implant and its host mammalian body, the method comprising the steps of: (a) implanting a sensor array into the mammalian body, the sensor array accompanying a prosthesis also implanted into the mammalian body; (b) sensing a condition of at least one of a predetermined component, a predetermined contaminant, and a predetermined property using the sensor array; (c)

generating signals responsive to the sensed condition; (d) wirelessly transmitting signals to a remote receiver outside of the mammalian body, the transmitted signals being representative of signals generated by the sensor array in response to sensing the condition; and (e) processing the transmitted signals by the remote receiver to generate data representative of the sensed condition.

[0024] In a more detailed embodiment of the first aspect, the prosthesis includes at least one of a knee replacement femoral prosthesis, a knee replacement tibial prosthesis, a knee replacement tibial tray prosthesis, a hip replacement femoral prosthesis, a hip replacement acetabular cup prosthesis, a hip replacement acetabular cup insert prosthesis, a trial knee replacement femora prosthesis, a trial knee replacement tibial prosthesis, a trial knee replacement tibial tray prosthesis, a trial hip replacement femoral prosthesis, a trial hip replacement acetabular cup prosthesis, and a trial hip replacement acetabular cup insert prosthesis. In yet another more detailed embodiment, the invention also includes filtering out low frequency noise from the generated signals prior to the wirelessly transmitting step. In a further detailed embodiment, the invention also includes amplifying the generated signals prior to the wirelessly transmitting step. In still a further detailed embodiment, the invention also includes multiplexing the generated signals prior to the wirelessly transmitting step. In a more detailed embodiment, the invention also includes converting the generated signals from analog to digital prior to the wirelessly transmitting step. In a more detailed embodiment, the invention also includes processing the generated signals prior to the wirelessly transmitting step. In another more detailed embodiment, the step of sensing the condition includes sensing at least one of pressure and temperature. In yet another more detailed embodiment, the step of sensing the condition includes utilizing at least one of a microcantilever and a microcapacitor. In still another more detailed embodiment, the step of sensing the condition includes sensing for markers of infection.

[0025] In yet another more detailed embodiment of the first aspect, the step of sensing the condition includes encapsulated sensors responsive to pressure changes. In still another more detailed embodiment, the step of sensing the condition includes sensors in fluid communication with bodily fluids bathing the prosthesis. In a further detailed embodiment, the invention also includes displaying visual representations of the data generated by or during the processing step, and responding to the displayed visual representations to take appropriate corrective action where applicable. In still a further detailed embodiment, the step of sensing the condition includes the use of encapsulated sensors responsive to pressure changes. In a more detailed embodiment, the step of sensing the condition includes sensing at least one of: leukocyte concentration, neutrophil concentration, bacterial deoxyribonucleic acid concentration, antibody concentration, glucose concentration, excitatory amino acids concentration, lactate dehydrogenase concentration, hyaluronic acid concentration, uric acid concentration, calcium pyrophosphate concentration, beta-glucuronidase concentration, nerve growth factor concentration, insulin-like growth factor concentration, Caeruloplasmin concentration, and oxidase concentration

[0026] It is a third aspect of the present invention to provide a method of detecting infection within mammalian body, the method comprising the steps of: (a) implanting a sensor array into the mammalian body, the sensor array accompanying a

prosthesis also implanted into the mammalian body; (b) sensing for a marker representative of infection; (c) generating signals from the sensor array when the marker representative of infection is sensed; (d) wirelessly transmitting signals to a remote receiver outside of the mammalian body, the transmitted signals being representative of signals generated by the sensor array in response to sensing the marker; and (e) processing the transmitted signals by the remote receiver to generate data representative of the sensed marker.

[0027] It is a fourth aspect of the present invention to provide a method of detecting premature failure of a prosthetic implant in a host mammalian body, the method comprising the steps of: (a) implanting a sensor array into the mammalian body, the sensor array accompanying a prosthesis also implanted into the mammalian body; (b) sensing conditions comprising at least one of pressure and constituents of mammalian bodily fluid bathing the prosthesis; (c) generating signals responsive to the sensed conditions; (d) wirelessly transmitting signals to a remote receiver outside of the mammalian body, the transmitted signals being representative of signals generated by the sensor array in response to sensing the conditions; and (e) processing the transmitted signals by the remote receiver to generate data representative of the sensed condition.

[0028] It is a fifth aspect of the present invention to provide a method of fabricating a prosthesis, the method comprising: (a) associating a prosthetic component with a fluid conduit adapted to be in fluid communication with a mammalian bodily fluid bathing the prosthetic joint; and (b) orienting a plurality of sensors into fluid communication with the interior of the fluid conduit, where the sensors are operative to detect at least one of a predetermined component, a predetermined contaminant, and a predetermined property.

[0029] It is a sixth aspect of the present invention to provide a method of fabricating a sensor array, the method comprising: (a) mounting a plurality of microcantilevers sensors onto a substrate in a predetermined distribution; and (b) encapsulating the microcantilever sensors.

[0030] It is a seventh aspect of the present invention to provide a method of fabricating a sensor array, the method comprising: (a) fabricating a plurality of capacitive sensors a plurality of microcantilevers sensors onto a substrate in a predetermined distribution; and (b) encapsulating the microcantilever sensors.

[0031] It is an eighth seventh aspect of the present invention to provide an external brace for supplementing the support structure of a mammalian body, the device comprising: (a) an external brace for mounting to the exterior of a mammalian body, the brace including a sensor array mounted thereto; and (b) an electronics structure for receiving data from the sensor array and wirelessly transmitting representative data to a remote receiver.

[0032] It is a ninth aspect of the present invention to provide a sensor array comprising: (a) a first capacitive sensor comprising conductive plates separated by a dielectric material, the capacitive plates of the first capacitive sensor lying along a first X-Y and operative to detect pressure along the X axis; (b) a second capacitive sensor comprising conductive plates separated from one another, the capacitive plates of the second capacitive sensor lying along the first X-Y plane and operative to detect pressure along the Y axis; and (c) third capacitive sensor comprising conductive plates separated from one another, the capacitive plates of the third capacitive

sensor lying along the first X-Y plane and operative to detect pressure along a Z plane orthogonal to the first X-Y plane.

[0033] It is a tenth aspect of the present invention to provide a prosthetic trial implant having a microcantilevered sensor array integral to the prosthetic trial implant and operatively coupled to a transmitter to communicate sensed data to a remote transmitter, where the sensed data is indicative of current conditions of a fluid in communication with at least one sensor of the sensor array.

[0034] It is an eleventh aspect of the present invention to provide a prosthesis having a microcantilevered sensor array integral to the prosthetic permanent implant and operatively coupled to a transmitter to communicate sensed data to a remote transmitter, the sensor array and transmitter including inductively powered and operative to detect at least one of temperature, pressure, and pH of a fluid in communication with at least one sensor of the sensor array.

[0035] It is a twelfth aspect of the present invention to provide a prosthetic implant including a microelectromechanical controller coupled to a microcantilevered sensor array integral to the prosthetic implant and operative to sense environmental conditions relative to the prosthetic implant to detect wear of the prosthetic implant more than three months subsequent to a prosthetic implant surgery and provide data to a remote data receiving device operative to allow a physician to determine whether adjustments and/or surgical repair is warranted.

[0036] It is a thirteenth aspect of the present invention to provide a prosthetic implant comprising: (a) a prosthetic support structure operative to be mounted to a preexisting support structure of a mammalian body; (b) a sensor array having a plurality of sensors, where at least one of the sensors is operative to detect at least one of viscosity of the synovial fluid; pH of the synovial fluid; cell count within the synovial fluid; protein within the synovial fluid; phospholipids within the synovial fluid; hyaluronic acid within the synovial fluid; leukocytes within the synovial fluid; neutrophils within the synovial fluid; bacterial deoxyribonucleic acid within the synovial fluid; antibodies within the synovial fluid; glucose concentration within the synovial fluid; lactate dehydrogenase (LDH) within the synovial fluid; uric acid crystals within the synovial fluid; NEMP-9 antigens (gelatinase-B) within the synovial fluid; nerve growth factor within the synovial fluid; excitatory amino acids (EAA) glutamate and aspartate within the synovial fluid; insulin-like growth factor 1 (IGF-1) and its binding proteins (IGFBP) 3 and 4 within the synovial fluid; oxidase activity within the synovial fluid; polyamine oxidases within the synovial fluid; caeruloplasmin (Cp) concentration within the synovial fluid; beta-glucuronidase content within the synovial fluid; S100A8/A9 within the synovial fluid; C reactive protein within the synovial fluid; rheumatoid factor within the synovial fluid; C3 and C4 within the synovial fluid; metal particulate within the synovial fluid; polyethylene particulate within the synovial fluid; bone particulate within the synovial fluid; cement particulate within the synovial fluid; osteolytic enzymes within the synovial fluid; genetic markers within the synovial fluid; antibody markers within the synovial fluid; temperature of the synovial fluid; specific gravity of the synovial fluid; and white cells (and differential cell type) within the synovial fluid; and (c) a transmitter in electrical communication with at least one sensor of the sensor array and operative to transmit data to a remote receive indicative of at least one of viscosity of the synovial fluid; pH of the synovial fluid; cell count within the

synovial fluid; protein within the synovial fluid; phospholipids within the synovial fluid; hyaluronic acid within the synovial fluid; leukocytes within the synovial fluid; neutrophils within the synovial fluid; bacterial deoxyribonucleic acid within the synovial fluid; antibodies within the synovial fluid; glucose concentration within the synovial fluid; lactate dehydrogenase (LDH) within the synovial fluid; uric acid crystals within the synovial fluid; MMP-9 antigens (gelatinase-B) within the synovial fluid; nerve growth factor within the synovial fluid; excitatory amino acids (EAA) glutamate and aspartate within the synovial fluid; insulin-like growth factor 1 (IGF-1) and its binding proteins (IGFBP) 3 and 4 within the synovial fluid; oxidase activity within the synovial fluid; polyamine oxidases within the synovial fluid; caeruloplasmin (Cp) concentration within the synovial fluid; beta-glucuronidase content within the synovial fluid; S100A8/A9 within the synovial fluid; C reactive protein within the synovial fluid; rheumatoid factor within the synovial fluid; C3 and C4 within the synovial fluid; metal particulate within the synovial fluid; polyethylene particulate within the synovial fluid; bone particulate within the synovial fluid; cement particulate within the synovial fluid; osteolytic enzymes within the synovial fluid; genetic markers within the synovial fluid; antibody markers within the synovial fluid; temperature of the synovial fluid; specific gravity of the synovial fluid; and white cells (and differential cell type) within the synovial fluid.

[0037] It is a fourteenth aspect of the present invention to provide a prosthesis for implantation into a mammalian body, the device comprising: (a) a prosthesis for implantation into a mammalian body that includes a sensor array comprising a plurality of sensors mounted to the prosthesis; and (b) an electronics structure for receiving signals from the sensor array and wirelessly transmitting representative signals to a remote receive, where the plurality of sensors are operative to sense pressure, applied to the prosthesis by another object, in at least two axes generally perpendicular to one another.

[0038] In a more detailed embodiment of the fourteenth aspect, the electronics structure includes a timing circuit configured to automatically activate the sensor array and to automatically deactivate the sensor array. In yet another more detailed embodiment, the plurality of sensors include at least one of resistive microcantilevers, piezoelectric microcantilevers, and microcapacitor sensors. In a further detailed embodiment, the prosthesis includes at least one of a knee replacement femoral prosthesis, a knee replacement tibial prosthesis, a knee replacement tibial tray prosthesis, a hip replacement femoral prosthesis, a hip replacement acetabular cup prosthesis, a hip replacement acetabular cup insert prosthesis, a trial knee replacement femoral prosthesis, a trial knee replacement tibial prosthesis, a trial knee replacement tibial tray prosthesis, a trial hip replacement femoral prosthesis, a trial hip replacement acetabular cup prosthesis, and a trial hip replacement acetabular cup insert prosthesis. In still a further detailed embodiment, at least one of the sensor array and the electronics structure is powered using at least one of electromagnetic induction, radio frequency induction, and battery power. In a more detailed embodiment, the electronics structure includes a microcontroller and a transmitter. In a more detailed embodiment, the electronics structure includes an application specific integrated circuit, which includes a filter for filtering out low frequency noise. In another more detailed embodiment, the electronics structure includes an application specific integrated circuit, which includes an amplifier for amplifying signals from the sensor array. In yet

another more detailed embodiment, the electronics structure includes an application specific integrated circuit, which includes a multiplexer for multiplexing signals from the sensor array. In still another more detailed embodiment, the electronics structure includes an application specific integrated circuit, which includes an analog-to-digital converter for converting analog signals from the sensor array to digital signals.

[0039] In yet another more detailed embodiment of the fourteenth aspect, the electronics structure includes an application specific integrated circuit, which includes a processor for processing signals from the sensor array. In still another more detailed embodiment, at least one of the plurality of sensors is operative to sense temperature. In a further detailed embodiment, the prosthesis includes a microchannel and a micropump in communication with the microchannel to pump mammalian bodily fluid bathing the joint through the microchannel, where an interior of the microchannel is in communication with at least one of the plurality of sensors.

[0040] It is a fifteenth aspect of the present invention to provide a prosthesis for implantation into a mammalian body, the device comprising: (a) a prosthesis for implantation into a mammalian body that includes a sensor array comprising a plurality of sensors mounted to the prosthesis; and (b) an electronics structure for receiving signals from the sensor array and wirelessly transmitting representative signals to a remote receiver, where at least one of the plurality of sensors is in fluid communication with fluids bathing the prosthesis.

[0041] In a more detailed embodiment of the fifteenth aspect, the sensor array includes sensors detecting at least one of a predetermined component, a predetermined contaminant, and a predetermined property. In yet another more detailed embodiment, the electronics structure includes a timing circuit configured to automatically activate the sensor array and to automatically deactivate the sensor array. In a further detailed embodiment, the plurality of sensors include at least one of resistive microcantilevers, piezoelectric microcantilevers, and microcapacitor sensors. In still a further detailed embodiment, the prosthesis includes at least one of a knee replacement femoral prosthesis, a knee replacement tibial prosthesis, a knee replacement tibial tray prosthesis, a hip replacement femoral prosthesis, a hip replacement acetabular cup prosthesis, a hip replacement acetabular cup insert prosthesis, a trial knee replacement femoral prosthesis, a trial knee replacement tibial prosthesis, a trial knee replacement tibial tray prosthesis, a trial hip replacement femoral prosthesis, a trial hip replacement acetabular cup prosthesis, and a trial hip replacement acetabular cup insert prosthesis. In a more detailed embodiment, at least one of the plurality of sensors of the sensor array is operative to sense at least one of: leukocyte concentration, neutrophil concentration, bacterial deoxyribonucleic acid concentration, antibody concentration, glucose concentration, excitatory amino acids concentration, lactate dehydrogenase concentration, hyaluronic acid concentration, uric acid concentration, calcium pyrophosphate concentration, beta-glucuronidase concentration, nerve growth factor concentration, insulin-like growth factor concentration, Caeruloplasmin concentration, and oxidase concentration.

[0042] In yet another more detailed embodiment of the fifteenth aspect, at least one of the sensor array and the electronics structure is powered using at least one of electromagnetic induction, radio frequency induction, and battery power. In still another more detailed embodiment, the electronics

structure includes a microcontroller and a transmitter. In a further detailed embodiment, the electronics structure includes an application specific integrated circuit, which includes a filter for filtering out low frequency noise. In still a further detailed embodiment, the electronics structure includes an application specific integrated circuit, which includes an amplifier for amplifying signals from the sensor array. In a more detailed embodiment, the electronics structure includes an application specific integrated circuit, which includes a multiplexer for multiplexing signals from the sensor array. In a more detailed embodiment, the electronics structure includes an application specific integrated circuit, which includes an analog-to-digital converter for converting analog signals from the sensor array to digital signals. In another more detailed embodiment, the electronics structure includes an application specific integrated circuit, which includes a processor for processing signals from the sensor array. In yet another more detailed embodiment, the prosthesis includes a microchannel and a micropump in communication with the microchannel to pump mammalian bodily fluid bathing the joint through the microchannel, where an interior of the microchannel is in communication with at least one of the plurality of sensors. In yet a further more detailed embodiment, the wireless transmission of representative signals is accomplished using a radio frequency transmitter.

[0043] It is a sixteenth aspect of the present invention to provide a method of monitoring a prosthetic implant and its host mammalian body, the method comprising the steps of: (a) implanting a sensor array into the mammalian body, the sensor array mounted to a prosthesis also implanted into the mammalian body; (b) sensing pressure applied to the prosthesis in at least two axes generally perpendicular to one another; (c) generating signals responsive to the sensed pressure applied to the prosthesis by another object; and (d) wirelessly transmitting signals to a remote receiver outside of the mammalian body, the transmitted signals being representative of signals generated by the sensor array in response to sensing the pressure.

[0044] In a more detailed embodiment of the sixteenth aspect, the prosthesis includes at least one of a knee replacement femoral prosthesis, a knee replacement tibial prosthesis, a knee replacement tibial tray prosthesis, a hip replacement femoral prosthesis, a hip replacement acetabular cup prosthesis, a hip replacement acetabular cup insert prosthesis, a trial knee replacement femoral prosthesis, a trial knee replacement tibial prosthesis, a trial knee replacement tibial tray prosthesis, a trial hip replacement femoral prosthesis, a trial hip replacement acetabular cup prosthesis, and a trial hip replacement acetabular cup insert prosthesis. In yet another more detailed embodiment, the method also includes filtering out low frequency noise from the generated signals prior to the wirelessly transmitting step. In a further detailed embodiment, the method also includes amplifying the generated signals prior to the wirelessly transmitting step. In still a further detailed embodiment, the method also includes multiplexing the generated signals prior to the wirelessly transmitting step. In a more detailed embodiment, the method further includes converting the generated signals from analog to digital prior to the wirelessly transmitting step. In a more detailed embodiment, the method further includes processing the generated signals prior to the wirelessly transmitting step. In another more detailed embodiment, the step of sensing the condition includes sensing at least one of pressure and temperature. In yet another more detailed embodiment, the step

of sensing the condition includes utilizing at least one of a microcantilever and a microcapacitor. In still another more detailed embodiment, the step of sensing the condition includes sensing for markers of infection.

[0045] In yet another more detailed embodiment of the sixteenth aspect, the step of sensing the condition includes encapsulated sensors responsive to pressure changes. In still another more detailed embodiment, the step of sensing the condition includes sensors in fluid communication with bodily fluids bathing the prosthesis. In a further detailed embodiment, the method further includes displaying visual representations of the data generated by or during the processing step, and responding to the displayed visual representations to take appropriate corrective action where applicable. In still a further detailed embodiment, the step of sensing the condition includes the use of encapsulated sensors responsive to pressure changes. In a more detailed embodiment, the step of sensing the condition includes sensing at least one of: leukocyte concentration, neutrophil concentration, bacterial deoxyribonucleic acid concentration, antibody concentration, glucose concentration, excitatory amino acids concentration, lactate dehydrogenase concentration, hyaluronic acid concentration, uric acid concentration, calcium pyrophosphate concentration, beta-glucuronidase concentration, nerve growth factor concentration, insulin-like growth factor concentration, Caeruloplasmin concentration, and oxidase concentration. In a more detailed embodiment, the method further includes processing the transmitted signals by the remote receiver to generate data representative of the sensed pressure.

[0046] It is a seventeenth aspect of the present invention to provide a method of monitoring a prosthetic implant and its host mammalian body, the method comprising the steps of: (a) implanting a sensor array into the mammalian body, the sensor array mounted to a prosthesis also implanted into the mammalian body, where at least one sensor of the sensor array is in fluid communication with fluids bathing the prosthesis; (b) sensing a condition of at least one of a predetermined component, a predetermined contaminant, and a predetermined property using the sensor array; (c) generating signals responsive to the sensed condition; and (d) wirelessly transmitting signals to a remote receiver outside of the mammalian body, the transmitted signals being representative of signals generated by the sensor array in response to sensing the condition.

[0047] In a more detailed embodiment of the seventeenth aspect, the prosthesis includes at least one of a knee replacement femoral prosthesis, a knee replacement tibial prosthesis, a knee replacement tibial tray prosthesis, a hip replacement femoral prosthesis, a hip replacement acetabular cup prosthesis, a hip replacement acetabular cup insert prosthesis, a trial knee replacement femoral prosthesis, a trial knee replacement tibial prosthesis, a trial knee replacement tibial tray prosthesis, a trial hip replacement femoral prosthesis, a trial hip replacement acetabular cup prosthesis, and a trial hip replacement acetabular cup insert prosthesis. In yet another more detailed embodiment, the method further comprises filtering out low frequency noise from the generated signals prior to the wirelessly transmitting step. In a further detailed embodiment, the method further comprises amplifying the generated signals prior to the wirelessly transmitting step. In still a further detailed embodiment, the method further comprises multiplexing the generated signals prior to the wirelessly transmitting step. In a more detailed embodiment, the

method further comprises converting the generated signals from analog to digital prior to the wirelessly transmitting step. In a more detailed embodiment, the method further comprises processing the generated signals prior to the wirelessly transmitting step. In another more detailed embodiment, the step of sensing the condition includes sensing at least one of pressure and temperature. In yet another more detailed embodiment, the step of sensing the condition includes utilizing at least one of a microcantilever and a microcapacitor. In still another more detailed embodiment, the step of sensing the condition includes sensing for markers of infection.

[0048] In yet another more detailed embodiment of the seventeenth aspect, the step of sensing the condition includes encapsulated sensors responsive to pressure changes. In still another more detailed embodiment, the step of sensing the condition includes sensors in fluid communication with bodily fluids bathing the prosthesis. In a further detailed embodiment, the method further comprises displaying visual representations of the data generated by or during the processing step, and responding to the displayed visual representations to take appropriate corrective action where applicable. In still a further detailed embodiment, the step of sensing the condition includes the use of encapsulated sensors responsive to pressure changes. In a more detailed embodiment, the step of sensing the condition includes sensing at least one of: leukocyte concentration, neutrophil concentration, bacterial deoxyribonucleic acid concentration, antibody concentration, glucose concentration, excitatory amino acids concentration, lactate dehydrogenase concentration, hyaluronic acid concentration, uric acid concentration, calcium pyrophosphate concentration, beta-glucuronidase concentration, nerve growth factor concentration, insulin-like growth factor concentration, Caeruloplasmin concentration, and oxidase concentration. In a more detailed embodiment, the method further comprises processing the transmitted signals by the remote receiver to generate data representative of the sensed condition.

[0049] It is an eighteenth aspect of the present invention to provide a method of fabricating a prosthesis, the method comprising: (a) fabricating a prosthesis with a fluid conduit adapted to be in fluid communication with a mammalian bodily fluid bathing the prosthetic joint; and (b) orienting a plurality of sensors into fluid communication with the interior of the fluid conduit, where the sensors are operative to detect at least one of a predetermined component, a predetermined contaminant, and a predetermined property.

[0050] It is a nineteenth aspect of the present invention to provide a sensor array comprising: (a) a first capacitive sensor comprising conductive plates separated by a dielectric material, the capacitive plates of the first capacitive sensor lying along a first X-Y and operative to detect pressure along the X axis; (b) a second capacitive sensor comprising conductive plates separated from one another, the capacitive plates of the second capacitive sensor lying along the first X-Y plane and operative to detect pressure along the Y axis; and (c) a third capacitive sensor comprising conductive plates separated from one another, the capacitive plates of the third capacitive sensor lying along the first X-Y plane and operative to detect pressure along a Z plane orthogonal to the first X-Y plane.

[0051] It is a twentieth aspect of the present invention to provide a prosthetic implant comprising: (a) a prosthetic sensor array mounted to a prosthesis, the sensor array including at least one sensor in fluid communication with a fluid surrounding the prosthesis subsequent to implanting the pros-

thesis into a mammalian body, where the at least one sensor is operative to detect at least one of the following properties: viscosity of the synovial fluid; pH of the synovial fluid; cell count within the synovial fluid; protein within the synovial fluid; phospholipids within the synovial fluid; hyaluronic acid within the synovial fluid; leukocytes within the synovial fluid; neutrophils within the synovial fluid; bacterial deoxyribonucleic acid within the synovial fluid; antibodies within the synovial fluid; glucose concentration within the synovial fluid; lactate dehydrogenase (LDH) within the synovial fluid; uric acid crystals within the synovial fluid; NIMP-9 antigens (gelatinase-B) within the synovial fluid; nerve growth factor within the synovial fluid; excitatory amino acids (EAA) glutamate and aspartate within the synovial fluid; insulin-like growth factor 1 (IGF-1) and its binding proteins (IGFBP) 3 and 4 within the synovial fluid; oxidase activity within the synovial fluid; polyamine oxidases within the synovial fluid; caeruloplasmin (Cp) concentration within the synovial fluid; beta-glucuronidase content within the synovial fluid; S100A8/A9 within the synovial fluid; C reactive protein within the synovial fluid; rheumatoid factor within the synovial fluid; C3 and C4 within the synovial fluid; metal particulate within the synovial fluid; polyethylene particulate within the synovial fluid; bone particulate within the synovial fluid; cement particulate within the synovial fluid; osteolytic enzymes within the synovial fluid; genetic markers within the synovial fluid; antibody markers within the synovial fluid; temperature of the synovial fluid; specific gravity of the synovial fluid; and white cells (and differential cell type) within the synovial fluid; and (b) a transmitter in electrical communication with the at least one sensor of the sensor array and operative to transmit data to a remote receive indicative of at least one sensed property.

BRIEF DESCRIPTION OF THE DRAWINGS

[0052] FIG. 1 is a frontal view of an exemplary tibial tray in accordance with the present invention;

[0053] FIG. 2 is a left side view of the exemplary tibial tray of FIG. 1;

[0054] FIG. 3 is a frontal view of an exemplary tibial tray insert in accordance with the present invention;

[0055] FIG. 4 is a left side view of the exemplary tibial tray insert of FIG. 3;

[0056] FIG. 5 is a top view of an exemplary femoral prosthesis in accordance with the present invention;

[0057] FIG. 6 is a left side view of the exemplary femoral prosthesis of FIG. 5;

[0058] FIG. 7 is an exemplary schematic representation of the electronic functions carried out by the exemplary control electronics of the present invention;

[0059] FIG. 8 is a wiring diagram of the electronics in communication with the sensors of the first exemplary embodiment of the present invention;

[0060] FIG. 9 is a wiring diagram of the amplifier and low pass filter in accordance with the first exemplary embodiment of the present invention;

[0061] FIG. 10 is a wiring diagram of the feedback display in accordance with the first exemplary embodiment of the present invention;

[0062] FIG. 11 is a wiring diagram of the interface with the transmitter in accordance with the first exemplary embodiment of the present invention;

[0063] FIG. 12 is a wiring diagram of the microcontroller in accordance with the first exemplary embodiment of the present invention;

[0064] FIG. 13 is a wiring diagram of the power management hardware in accordance with the first exemplary embodiment of the present invention;

[0065] FIG. 14 is a wiring diagram of the switch in accordance with the first exemplary embodiment of the present invention;

[0066] FIG. 15 is a wiring diagram of the JTAG interface with an output device in accordance with the first exemplary embodiment of the present invention;

[0067] FIG. 16 is a wiring diagram of the ASK transmitter in accordance with the first exemplary embodiment of the present invention;

[0068] FIG. 17 is an exemplary orientational diagram representing a first exemplary capacitor structure incorporated into an exemplary sensor for use with the first exemplary embodiment of the present invention;

[0069] FIG. 18 is an exemplary orientational diagram representing a second exemplary capacitor structure incorporated into an exemplary sensor for use with the first exemplary embodiment of the present invention;

[0070] FIG. 19 is an exemplary orientational diagram representing a third exemplary capacitor structure incorporated into an exemplary sensor for use with the first exemplary embodiment of the present invention;

[0071] FIG. 20 is an exemplary orientational diagram representing load cell for use with the first exemplary embodiment of the present invention;

[0072] FIG. 21 is an exemplary process flow diagram for fabricating an exemplary sensor for use with the first exemplary embodiment of the present invention;

[0073] FIG. 22 is an elevated perspective view of an exemplary microcantilever sensor for use with the first exemplary embodiment of the present invention;

[0074] FIG. 23 is an overhead view of the exemplary microcantilever of FIG. 22 calling out the integrated Wheatstone bridge;

[0075] FIG. 24 is an overhead diagram of an exemplary cantilever with dimensions in μm ;

[0076] FIG. 25 is an exemplary schematic diagram showing the interaction between hardware components to sense conditions and generate data manipulate the data, and transmit the data to a remote devices in accordance with the first exemplary embodiment of the present invention;

[0077] FIGS. 26-28 are graphical depictions from a visual display representing various degrees of a sensed condition, such as pressure or concentration of a chemical species.

[0078] FIG. 29 is an exemplary piezoresistive microcantilever sensor mounted within a microchannel for sensing components, contaminants, and properties for use with the first exemplary embodiment of the present invention;

[0079] FIG. 30 is an exemplary capacitive microcantilever sensor mounted within a microchannel for sensing components, contaminants, and properties for use with the first exemplary embodiment of the present invention;

[0080] FIG. 31 is an exemplary tibial tray housing a dual-layer structure for use with the exemplary capacitive or piezoresistive microcantilevers of the present invention;

[0081] FIG. 32 is an overhead, exposed view of the tibial tray of FIG. 31 showing the exemplary layout of the capacitive or piezoresistive microcantilevers of the present inven-

tion, as well as the micropumps feeding fluid into the microchannels and discharging fluid from the microchannels;

[0082] FIG. 33 is an exposed view of a micropump in accordance with the present invention showing how fluid flows through the pump as an electric potential is applied at the terminals;

[0083] FIG. 34 is a schematic diagram showing the electrical connection between the sensors and control circuitry for use with the present invention;

[0084] FIG. 35 is a schematic view of the phenomenon of electro-osmotic flow and the equation governing the flow transport; and

[0085] FIG. 36 is a schematic view of the effect of an electrical double layer on fluid flow.

DETAILED DESCRIPTION

[0086] The exemplary embodiments of the present invention are described and illustrated below to encompass miniature sensors for use in the healthcare industry, such as sensors for use with prosthetic implants and prosthetic trials. Of course, it will be apparent to those of ordinary skill in the art that the preferred embodiments discussed below are exemplary in nature and may be reconfigured without departing from the scope and spirit of the present invention. However, for clarity and precision, the exemplary embodiments as discussed below may include optional steps, methods, and features that one of ordinary skill should recognize as not being a requisite to fail within the scope of the present invention.

[0087] Referencing FIGS. 1-6, a first exemplary embodiment of the present invention includes a prosthetic knee joint for use with a total knee arthroplasty procedure. The knee joint comprises a tibial tray 12, a tray insert 14, and a femoral prosthesis 16. The interaction and assembly of simple tibial trays, tray inserts, and femoral prostheses are well known to those skilled in the art. Consistent with the interaction of these simple prosthetic components, the exemplary components 12, 14, 16 of the knee joint of the present invention integrate and function as a replacement knee joint without compromising the primary functionality of the joint itself.

[0088] Referring specifically to FIGS. 1 and 2, the tibial tray 12 includes a downwardly extending shaft 18 mounted to a horizontal platform 24. The vertical shaft 18 houses an encoding and modulation device (EMD) 28 in communication with a microtransmitter 22. A sensor array 20 is mounted to the horizontal platform 24 that is also in communication with the EMD 28. An antenna 26 is mounted to the horizontal platform 24 and in communication with the microtransmitter 22, which receives signals from the EMD 28 to be transmitted to a remote electronic receiver (not shown). The sensor array 20 is distributed over the relevant areas of the platform 24 to effectively map those areas of the platform 24 contacted by the tray insert 14. The sensor array 20 may also include sensors adapted to sense components, contaminants, and properties exhibited by bodily fluids that surround the joint 10 subsequent to implantation. Regardless of the sensors utilized and particular data generated, detection data is communicated to the EMD 28, which in turn communicates data to the microtransmitter 22 that wirelessly transmits data using the antenna 32 to a remote electronic receiver 91 (see FIG. 25). Exemplary remote electronic receivers 91 include, without microcontroller based electronics such as a wireless telephone, a wireless personal data assistant, a personal computer, whether or not the electronic component includes a visual display. In an exemplary scenario, the remote receiver

digital processes the signal from the implanted transmitter to generate a 3D graph that displays the load distribution on the sensing surface, as well as composition profiles for predetermined components, contaminants, and properties (see FIGS. 26-28).

[0089] Referencing FIGS. 3 and 4, the tibial insert 14 includes an upper vertical post 30 extending from a base 34 opposite that of a lower vertical post 31 (in some tibial inserts the lower vertical post 31 may be absent). The upper vertical post 30 includes an antenna 32 in communication with a microtransmitter 40 housed within the base 34, as well as a sensor array 36 and an EMD 38 also mounted within the base 34. The base 34 is contoured to include a pair of articular surfaces 42 adapted to receive the condyles 50 of the femoral prosthesis 16 (see FIGS. 5 and 6). Some of the sensors of the array 36 are positioned underneath the articular surfaces 42 in a predetermined manner that operates to map the relevant areas of the articular surfaces 42 that will be contacted by the condyles 50 throughout the range of movement of the joint 10 to generate data representative of a pressure map across the articular surfaces 42. The sensor array 36 also may include sensors that detect certain components, contaminants, and properties relevant to the joint 10 (see [0076]-[0077], for example) and generate detection data representative of the component, contaminant, or property detected. The detection data generated by the sensors of the array 36, whether pressure related or otherwise, is communicated to the ENID 38, which in turn communicates data to the microtransmitter 40 that wirelessly transmits data using the antenna 32 to a remote electronic receiver 91 (see FIG. 25).

[0090] Referencing FIGS. 5 and 6, the femoral prosthesis 16 includes a pair of U-shaped condyles having a sensor array 52 in communication with an EMD 54, a microtransmitter 56, and an antenna 58. Numerous sensors of the array 52 are mounted to the condyles 50 to detect pressures exerted against the condyles, whereas other sensors within the array 52 may be adapted to be in fluid communication with the bodily fluids surrounding the joint 10 subsequent to the femoral prosthesis 16 being implanted. Those sensors of the array 52 that are in fluid communication with the bodily fluids surrounding the joint are operative to detect certain components, contaminants, and properties relevant to the joint 10 (see [0076]-[0077], for example) and generate detection data representative of the component, contaminant, or property detected. All of the detection data generated by the sensors of the array 52, whether pressure related or otherwise, is communicated to the EMD 54. The EMD 54 manipulates this data prior to communicating it to the microtransmitter 56 that wirelessly transmits data using the antenna 58 to a remote electronic receiver 91.

[0091] Referring to FIGS. 7 and 8, the EMDs 28, 38, 54 of the exemplary embodiments comprise ultra low-power, Application Specific integrated Circuit (ASIC) or System on Chip (SOC) that includes, as will be described in detail below, signal detection and amplification functionality, anti-alias filtering functionality, multiplexing functionality, analog to digital conversion functionality, data processing functionality and transmission functionality. The SOC is programmed in accordance with the flowchart of FIG. 7 and designed for battery powering, such as a coin cell battery. A schematic diagram of the SOC is shown in FIG. 8, with the aforementioned component functions discussed in more detail below.

Signal Conditioning and Amplification

[0092] Generally, the output signal of each sensor is very small. In this regard, it is important to include a circuit **70** that filters out low frequency noise and amplifies the desired signal with an instrumentation amplifier into the SOC. The gain of the amplifier is adjustable with one off-chip resistor.

Analog Multiplexer

[0093] In order to obtain information of each sensor, an analog multiplexer (MUX) **72** is utilized between a readout circuit **74** and the signal conditioning circuit **70** of the system. The MUX **72** acts as a switch controlled by signals sent to the decoder from the microcontroller (MCU) **76**. In exemplary form, the MUX **72** uses five addressing signals to select one channel at a time from numerous (such as 30) channels sequentially. The ON-resistance among these numerous channels should be matched to increase the MUX **72** static accuracy. In order to work in a high-speed mode, the ON-resistance should be relatively small, which, in turn, may lead to large chip size. Those of ordinary skill will understand the implications when trading off between speed and die area.

Analog to Digital Conversion (ADC)

[0094] An 8-bit SAR ADC **78** was implemented in the exemplary SOC. Although Successive Approximation Register (SAR) ADC is a more complex analog-to-digital converting technique than digital ramp ADC, the former is much faster and the sampling time does not necessarily depend on the input voltage. An important part of the ADC **78** is a high resolution comparator, which has the ability to distinguish the minimum triggering signal with common mode voltage changing from 100 mV to 2 V. Consequentially, the SOC includes 256 quantization levels with precision of 7.4.mV. It is also important to match the 256 current sources to maintain good Integrated Non-Linearity (INL) and Differential Non-Linearity (DNL).

Data Processing

[0095] A comma generator and polarity check **80** are included with the SOC to facilitate distinguishing received data with their corresponding channels, as well as to facilitate detection of transmission errors. In exemplary form, an 8 bit start comma is sent prior to the signals from the first channel, and an end comma is sent after the last channel (channel 30, for example) signal. Thus, the receiver can check the received data's polarity to ensure the validity.

Transmitter

[0096] The transmitter **82** uses Amplitude Shift Keying (ASK) modulation with a carrier frequency at 433.92 MHz. As a result of potential inconsistencies in the Wheatstone bridge circuit, a feedback circuit with an off sensor is included with the SOC to ensure that it is balanced at all times.

[0097] Referring to FIGS. **10-16**, numerous exemplary wiring diagrams for various parts of the SOC and components of the remote receiver **91** are provided. For example, FIG. **10** is the wiring diagram for the display of the output signal for the remote receiver, while FIG. **11** is the wiring diagram of the interface switch to the transmitter of the SOC. FIG. **12** is the wiring diagram for the microcontroller, whereas FIG. **13** is the wiring diagram for the power supply circuit of the SOC. FIG. **14** is a wiring diagram to the switch of the output display

for the remote receiver **91**, while FIG. **15** is the interface circuit with the computer (acting as a remote receiver), and FIG. **16** is the wiring diagram for the ASK transmitter circuit of the SOC.

[0098] Referencing FIGS. **17-20**, a first exemplary set of sensors **(1), (2), (3)** for use in the exemplary arrays **20, 36, 52** include interdigitated capacitor sensors fabricated from bio-compatible materials. Pairs of electrodes are embedded in a polymer matrix to form capacitors that are responsive to deformation of the embedding material. More specifically, the capacitance of the capacitors changes as the spacing between the electrodes changes, which can be correlated to an exerted pressure resulting from changes in the configuration of the capacitor electrodes.

[0099] Referring to FIG. **20**, a load cell **106** includes a compilation of the exemplary interdigitated capacitor sensors. The load cell **106** includes a first sensor **(1)** comprised of two capacitor plates **90, 92** separated from one another. The load cell **106** also includes two second sensors **(2)** comprised of a two-layer differential capacitor comprising two electrodes **94, 96** with a potential applied between them, an overlapping electrode **98** at a floating potential, and a fourth electrode **100** underneath the floating electrode serving as a testing potential. The load cell **106** also includes three third sensors **(3)** comprised of opposing capacitor plates with numerous fingers **102, 104**.

[0100] Each of the sensors **(1), (2), (3)** is operative to measure a force from differing directions. A single first sensor **(1)** is operative to detect forces normal to the surface of the substrate. Dual second sensors **(2)** are arranged generally along the same plane, and also in the same plane as the first sensor **(1)**, but are angled 90 degrees with respect to one another to detect shear in the plane orthogonal to the substrate. Finally, three third sensors **(3)** are also arranged in the same plane as the first and second sensors **(1), (2)**, however, these sensors are angled 45 degrees with respect to one another and measure the in-plane strain. In sum, the load cell **106** provides an exemplary repeatable grouping of sensors in a single plane that are operative to detect exerted pressures in two dimensions of the plane, as well as in directions orthogonal to the plane to provide three dimensional mapping capabilities. An exemplary load cell **106** has dimension of 1 mmx1 mm, however, smaller dimensions are possible such as, without limitation, 0.1 mmx0.1 mm. An exemplar array **20, 36, 52** includes many multiples of load cells **106**, such as two to eight hundred load cells **106**.

[0101] Referencing FIG. **21**, fabrication of the first set of exemplary sensors includes utilization of MEMS fabrication techniques adapted from silicon-based microcontroller fabrication. In this exemplary embodiment, the first set of sensors may be either fabricated in an embedded state on the eventual prosthetic component, or may be fabricated remote from the eventual prosthetic component by as using a portable substrate structure such as medical-grade UHMW polyethylene, parylene films, or silicon wafers. Oxygen plasma reactive ion etching techniques may also be used as a surface pretreatment to enable the electrodes to adhere to certain substrate surfaces.

[0102] An initial procedure starts with obtaining a clean substrate surface at step **110**, which in this exemplary process includes a silicon wafer, a polyethylene wafer, and a parylene film. The silicon wafer is cleaned using the piranha process, a 5:1 ratio of H₂SO₄ to H₂O₂ at 120 C. The polyethylene wafer is cleaned using a liquinox liquid soap cleaning solution with

soft scrub, followed by an acetone rinse, a methanol rinse, and an isopropanol rinse. The surface of the polyethylene samples is then activated by exposure to an oxygen plasma or a combination of oxygen/nitrogen plasma. This step served to nano-roughen the surface and increase the energy of the surface by breaking down some of the polymer chains on the surface. The parylene substrate is oxidized with a 1 micron SiO₂ layer prior to applying 10 more microns of parylene.

[0103] After the substrates have been cleaned and prepared for photoresist deposition, step 112 comprises spin-coating each substrate with a Shipley S1818 photoresist at 3000 RPM for 30 seconds. Immediately subsequent to deposition of the photoresist, the substrates are soft-baked on a hot plate for 60 seconds at 90 C. Subsequent to the soft-baking step, contact lithography is used in step 114 to pattern transfer a positive mask onto the exposed surface of the substrates.

[0104] A baking step 116 follows the lithography step 114, where each substrate is baked for 80 minutes at 90 C in NH₃ gas in an image reversal oven. During the baking step 116, NH₃ gas diffuses into the exposed areas and neutralizes the byproducts of the photodecomposition process to render the exposed areas highly resistant to further change by exposure to light and insensitive to further developing.

[0105] Next, the substrates are subjected to a flood exposure step 118 for 60 seconds to render the areas adjacent to the neutralized areas soluble in the photoresist developer, thereby reversing the pattern originally exposed in the positive photoresist step 112. Each substrate is spray developed in a developer for 60 seconds, followed by a 30 second exposure to an oxygen plasma thereby ensuring that all of the photoresist is removed from the substrate in the developed areas, as shown by step 120.

[0106] Subsequently, a metal deposition step 122 includes evaporating 100 angstroms of titanium onto each substrate as an adhesion layer, followed by 1500 angstroms of gold comprising the bulk of the metal layer. In this exemplary process, the metal deposition step 122 covers the entire surface of the substrates, where the eventual structure is brought about by dissolving the photoresist in acetone or other photoresist solvent during the lift-off process, leaving metal only the desired areas. Each of the substrates is then cleaned in a polar solvent, such as methanol, resulting in the structure shown in step 124. Each subsequent layer of conductive material may be deposited by repeating the above recited process, interposing dielectric material between the conductive patterns. By way of example, and not limitation, an exemplary process might include a parylene dielectric coating step followed by photolithography patterning of vias and via etching in an oxygen plasma, and thereafter photolithographic masking and deposition of a subsequent electrode and trace layer. Those skilled in the art will understand the obvious alternatives drawn out by the aforementioned exemplary process.

[0107] Exemplary dimensions of the exemplary sensors (1), (2), (3) include, without limitation a 2 μm spacing between conductive plates having a thickness of approximately 2 μm, with length and widths depending upon the particular capacitive structure fabricated, which also may be said for the exemplary spacing and thickness dimensions recited.

[0108] Referring to FIGS. 22-24, a second set of exemplary sensors for use with the sensor arrays 20, 36, 52 of the present invention include sealed compartment sensors operative to measure in-vivo compartment pressures. The exemplary sen-

sors comprise piezoelectric cantilevers fabricated from single crystal silicon, with each cantilever including an integrated Wheatstone bridge for automated offset balance. Piezoresistive microcantilevers include piezoresistive materials such as doped silicon that change in resistance according to the amount of strain imparted from the change in crystal structure. Hence, the relationship between the change in resistivity and the change in length (strain) can be characterized and calibrated as a strain sensor.

[0109] Multiple piezoelectric microcantilevers are mounted onto FR4 epoxy laminate in a predetermined pattern and embedded within an enclosure of epoxy material to form a portion or all of an exemplary array, which in exemplary form includes nine microcantilevers spaced from one another to evenly cover an area of 1 mm×1 mm. Each microcantilever includes a pyramidal tip located at the very end of the cantilever beam with a thickness of approximately 17 μm and dimensions as shown in FIG. 24. An epoxy, such as an FDA approved epoxy, is applied to the pattern of microcantilevers to form a pattern of capsules having a thickness of less than 2 mm. Each microcantilever is connected to an EMD 28, 38, 54 that multiplexes, signal conditions, amplifies and quantizes the signals. Those of ordinary skill will understand that certain tests, such as uniform compression tests, may be necessary to correlate the change in resistance to strain of the exemplary piezoelectric microcantilevers arrays.

[0110] Referencing FIG. 25, each EMD 28, 38, 54 is designed to compensate and calibrate the imbalance in the Wheatstone bridge circuit due to the possible residual stress resulting from the epoxy encapsulation. A multiplexer 72 receives signals from the sensors of the array 20, 36, 52, where the multiplexed signals are conditioned by a signal conditioner 70, which transmits analog signals to a converter 78, thereby feeding digital signals to a microcontroller 71. The microcontroller 71 sends data signals to the transmitter 82, which ASK modulates the signals and disseminates the data in the form of radio frequency signals at 433.92 MHz. The EMD components are powered by an integral power source such as a battery, but may also be powered by electromagnetic induction or radio frequency (RF) induction. It is to be understood that the exemplary EMD structure of FIG. 25 may be utilized with other exemplary sensors and sensor arrays of the instant invention.

[0111] An exemplary remote receiver 91 includes a radio frequency receiver 93, a digital signal processor 95, and a display 97 for viewing the information derived from the wirelessly transmitted data. An on-board power supply 99 provides the necessary power to the components of the remote receiver, however, those of ordinary skill will understand that on-board power supplies may be replaced or supplemented by remote power supplies such as by way of power outlets. In exemplary form, the radio frequency signals are converted to electronic signals by the receiver 93 and output to the digital signal processor 95, which converts the signals into digital data that is output in an analog form to be viewed on the display 97, such as a liquid crystal display of a handheld device or computer monitor.

[0112] Referencing FIGS. 26-28, three exemplary data sets from a sensor array of the present invention are graphically depicted. In exemplary form, the graphical depictions reflect varying amounts of pressure detected by a certain sensor or groups of sensors of an array subsequent to implantation of the prosthesis. An exemplary graphical user interface includes a depiction of a three-dimensional model of the

prosthesis (not shown), allowing a user to move a cursor over the model to gain feedback from a particular sensor or group of sensors regarding exerted pressures or a concentration of a particular substance or group of substances. In this manner, a surgeon or attending physician obtains substantially real-time feedback regarding the load distributions on the prosthesis, as well as feedback regarding the onset of infection or an insidious condition such as premature failure or improper biomechanical alignment.

[0113] Referring to FIGS. 29 and 30, a third set of exemplary sensors for use with the sensor arrays 20, 36, 52 of the present invention include microchannels lined with MEMS microcantilever sensors 174 (resistive, FIG. 29, or capacitive, FIG. 30) to measure fluid properties and contaminations. These sensors are operative to detect certain components, contaminants, and properties relevant to the prosthetic joint and generate detection data representative of the component, contaminant, or property detected. Exemplary microcantilevers may be fabricated consistent with the disclosures of U.S. Pat. Nos. 6,289,717, 5,719,324, and 6,763,705, the disclosures of each of which are hereby incorporated by reference.

[0114] The following is a nonexhaustive, exemplary listing of the components, contaminants, and properties that may be detected in the synovial fluid that bathes the prosthetic joint. It is to be understood that the exemplary sensors for use with the present invention may detect or measure one or more of the following: viscosity of the synovial fluid; pH of the synovial fluid; cell count within the synovial fluid; protein within the synovial fluid; phospholipids within the synovial fluid; hyaluronic acid within the synovial fluid; leukocytes within the synovial fluid; neutrophils within the synovial fluid; bacterial deoxyribonucleic acid within the synovial fluid; antibodies within the synovial fluid; glucose concentration within the synovial fluid; lactate dehydrogenase (LDH) within the synovial fluid; uric acid crystals within the synovial fluid; MMP-9 antigens (gelatinase-B) within the synovial fluid; nerve growth factor within the synovial fluid; excitatory amino acids (EAA) glutamate and aspartate within the synovial fluid; insulin-like growth factor 1 (IGF-1) and its binding proteins (IGFBP) 3 and 4 within the synovial fluid; oxidase activity within the synovial fluid; polyamine oxidases within the synovial fluid; caeruloplasmin (Cp) concentration within the synovial fluid; beta-glucuronidase content within the synovial fluid; S100A8/A9 within the synovial fluid; C reactive protein within the synovial fluid; rheumatoid factor within the synovial fluid; C3 and C4 within the synovial fluid; metal particulate within the synovial fluid; polyethylene particulate within the synovial fluid; bone particulate within the synovial fluid; cement particulate within the synovial fluid; osteolytic enzymes within the synovial fluid; genetic markers within the synovial fluid; antibody markers within the synovial fluid; temperature of the synovial fluid; specific gravity of the synovial fluid; and white cells (and differential cell type) within the synovial fluid.

[0115] Referring to FIGS. 31-34, the third set of exemplary sensors may be incorporated into a dual layer design adapted to be embedded within one or more of the prosthetic implants 12, 14, 16. In this exemplary dual-layer structure, a first layer is comprised of a sensor layer 170 and a second layer is comprised of an electronics layer 172. The sensor layer 170 includes a plurality of functionalized microcantilevers 174, microfluidic channels 176, and micropumps 178. A small inlet 180 to the microfluidic channel corresponds with an opening through the prosthetic implant 12, 14, 16 (for

example, the tibial tray 12) to allow interstitial fluids to contact the sensor layer 170 of the array. The microfluidic channels 176 are in communication with the micropumps 178, which are operative to pump a fixed volume of interstitial fluid into contact with the microcantilevers 174 to allow generation of chemical analysis data representative of the constituency of the interstitial fluid exposed to the microcantilevers 174. A downstream portion 186 of the microfluidic channels 176 combines the individual fluid paths, subsequent to passing beyond the microcantilevers 174, into a single outlet stream that is removed by the action of a second micropump 178. Exemplary micropumps 178 include, without limitation, micropumps transporting fixed volumes of fluid under the influence of an electric field such as those disclosed in U.S. Pat. No. 6,733,244, the disclosure of which is incorporated by reference (see FIG. 33), as well as Alzet microosmotic pumps available from Durect Corporation (www.alzet.com).

[0116] Referencing FIG. 34, each sensor array 20, 36, 52 is in communication with an EMD (see FIG. 25) to receive deflection signals representative of the deflection of the functionalized microcantilevers 174. An amplifier 190 may interpose the microcantilevers 174 and EMD 28, 38, 54 to amplify the deflection signals of the functionalized microcantilevers 174.

[0117] A complementary pair of microcantilevers 174 may be utilized, one reference set corresponding to a controlled environment without any bound biochemical agents, while a second signal set, identical to the first set, is exposed to biochemical agents within the interstitial fluid. External vibrations cause both the signal and the reference cantilever set to vibrate and without the reference set, such vibrations might, in severe conditions, overwhelm the minute deflection forces resulting from the binding of biochemical agents to the microcantilevers 174. Subtracting the reference vibrations from the signal vibrations helps reduce this interference.

[0118] The output signal from each piezoresistive microcantilever 174 is measured using an on-chip Wheatstone bridge. One of the cantilevers then acts as a mechanical filter for the noise that both the measuring cantilever and the reference cantilever experience using the following expression:

$$\frac{V_0}{V_{bias}} = \frac{1}{4} \frac{\Delta R}{R}$$

The fractional change in resistance ($\Delta R/R$) of a piezoresistive cantilever is described by the following expression:

$$\frac{\Delta R}{R} = \beta \frac{3\pi_L(1-\nu)}{t} (\sigma_1 - \sigma_2) \quad \text{Equation (1)}$$

Where π_L is the piezoresistive coefficient of silicon along the axis, σ_1 is the longitudinal stress, σ_2 is the transverse stress, t is thickness of cantilever, ν is Poisson's ratio, and β is a factor that adjusts for the thickness of the piezoresistor. From Equation (1), the ratio ($\Delta R/R$) is proportional to differential stress ($\sigma_1 - \sigma_2$). Differential stress distribution over a cantilever surface depends on the geometric factors of the layers and the chemo-mechanical forces between the biomolecules and the capture or hybridization layers. Therefore, the deflection

signal can be increased by maximizing differential stress ($\sigma_1 - \sigma_2$) by changing the geometric factors.

[0119] The change in resistance of a piezoresistive cantilever is related to the analyte and receptor concentration by the following expression:

$$\Delta\sigma = (\Delta\sigma_0)[1 - e^{-k_f C_{\infty} N_r t}] \quad \text{Equation (2)}$$

$$\frac{\Delta R}{R} = \Pi[(\Delta\sigma_1)_0 - (\Delta\sigma_2)_0][1 - e^{-k_f C_{\infty} N_r t}] \quad \text{Equation (3)}$$

[0120] Where

[0121] Effective reaction rate $K_f = (K - a|u|)$, u =flow velocity;

[0122] $\Pi = \beta * 3\pi_x(1 - \nu)/t$ is the piezoresistor coefficient,

[0123] $(\Delta\sigma_1)_0 = \Delta G_1 N_0 A_m^{-1} A^{-1}$,

[0124] $(\Delta\sigma_2)_0 = \Delta G_2 N_0 A_m^{-1} A^{-1}$,

[0125] ΔG =change in the Gibbs free energy caused by the adsorption process;

[0126] N_r =Number of available receptors;

[0127] C_{∞} =analyte concentration;

[0128] A_m =area of receptor coating; and

[0129] A =number of analyte molecules per mole.

[0130] Also, the deflection (z) of the tip of an ordinary microcantilever is calculated from using Stoney's Equation:

$$z = \frac{3l^2(1 - \nu)}{Et_m^2} \Delta\sigma \quad \text{Equation (4)}$$

where λ , ν , E , $\Delta\sigma$, and t_m are the microcantilever's effective length, Poisson's ratio, Young's modulus, differential surface stress and its thickness. Using Equations (2) and (4), the deflection of the cantilever due to surface stresses is measured.

[0131] From Equations (2), (3), & (4), it is clear that in order to measure the change in resistance, one needs to know the analyte concentration and the number of available receptors and the flow velocity of the fluid.

[0132] To achieve this, the micropump is used to generate a predetermined flow. Electro-osmotic flow is particularly suitable for microfluidic channels with diameters of less than 0.1 mm. The phenomenon of electro-osmotic flow and the equation governing the flow transport are discussed below.

[0133] As the characteristic dimensions of the channels decrease to micro ranges, the fluid flow behaviors are increasingly influenced by interfacial effects such as the electrical double layer (EDL). Because of the EDL influence, the microchannel flows deviate from predications of the traditional Navier-Stokes equations. The large surface-area-to-volume ratio in the microchannel causes the excess shear stress effect of the flow.

[0134] For example, consider a microchannel located between two parallel plates with its coordinate system shown in the following depiction:

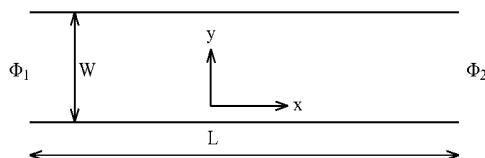

[0135] To consider EDL and electrostatic field effects on fluid flow through the microchannel, the distribution of electrical potential and net charge density between the two plates must be evaluated. Consider a liquid phase containing positive and negative ions in contact with a planar negatively charged surface. An EDL field will be established. According to the theory of electrostatics, the relationship between the electrical potential and the net charge density per unit volume ρ_e at any point in the solution is described by the two-dimensional Poisson equation

$$\frac{\partial^2 \psi}{\partial x^2} + \frac{\partial^2 \psi}{\partial y^2} = -\frac{\rho_e}{\epsilon \epsilon_0} \quad \text{Equation 5}$$

Where, ρ_e is the charge density, ϵ is the dielectric constant of the medium, and ϵ_0 is permittivity of vacuum. For any fluid consisting of two kinds of ions of equal and opposite charge (Z^+ and Z^-), the number of ions of each type is given by the Boltzmann equation

$$n^+ = n_0 e^{ze\psi/k_b T}, \quad n^- = n_0 e^{-ze\psi/k_b T} \quad \text{Equation 6}$$

where n^+ and n^- are the concentrations of the positive and negative ions, n_0 is bulk concentration of ions, $e^{ze\psi/k_b T}$ is the Boltzmann factor, k_b is the Boltzmann constant,

and T is the absolute temperature. The local net charge density in a unit volume of the fluid is given by

$$\rho_e = (n^+ - n^-)ze = -2n_0ze \sinh(ze\psi/k_b T) \quad \text{Equation 7}$$

Substituting Equation 7 into Equation 5, we obtain a nonlinear two dimensional Poisson-Boltzmann equation,

$$\frac{\partial^2 \psi}{\partial x^2} + \frac{\partial^2 \psi}{\partial y^2} = \frac{2n_0ze}{\epsilon \epsilon_0} \sinh(ze\psi/k_b T).$$

[0136] Microchannel flow is changed by the presence of an electrostatic potential field. For the current study of electro-osmotic flow, it is assumed that the applied electrostatic potential is much larger than the streaming potential induced by the current due to transport of charges by the liquid flow. Therefore, we obtain the distribution of the electrostatic field by solving the Laplace equation:

$$\frac{\partial^2 \phi}{\partial x^2} + \frac{\partial^2 \phi}{\partial y^2} = 0$$

[0137] The Navier-Stokes equations mathematically represent the fluid flow in general cases. However, they have to be modified for the case of microchannel flow to include the electrical force generated by the interaction between EDL and the electrical potential field. The equations of motion for an incompressible liquid are given by

$$\nabla \cdot \bar{u} = 0$$

$$\frac{\partial \bar{u}}{\partial t} + \bar{u} \cdot \nabla \bar{u} = -\frac{1}{\rho f} \nabla p + \frac{\mu}{\rho f} \nabla^2 \bar{u} - \frac{\rho_e}{\rho f} (\nabla(\psi + \phi))$$

In this equation, \bar{u} is the velocity vector containing u and v components along the x and y directions, ρ_f and μ are the density and dynamic viscosity of the liquid, respectively, and ρ_e is the charge density.

[0138] The channel length is assumed to be long enough that the flow is fully developed at the outflow boundary. Initially, liquid fluid fills the channel and the flow is stationary. An equilibrium electrical double layer is formed near wall boundaries. Once the driving force (the static electrical potential at the inlet) is activated, the flow starts to move. No slip velocity boundary conditions are used at the walls. At the flow inlet, the zero velocity gradient is assumed because the mass flow rate is determined by the activated electrical potential.

[0139] The boundary conditions applied for this case are:

$$X = 0 \quad \frac{\partial u}{\partial x} = 0, \quad \frac{\partial v}{\partial x} = 0, \quad \frac{\partial p}{\partial x} = 0, \quad \frac{\partial \psi}{\partial x} = 0, \quad \phi = C_1$$

$$X = L \quad \frac{\partial u}{\partial x} = 0, \quad \frac{\partial v}{\partial x} = 0,$$

$$p(l, y) = \int_0^y G_x \cdot \sinh \psi \frac{\partial \psi}{\partial y} dy, \quad \frac{\partial \psi}{\partial y} = 0, \quad \phi = C_2$$

$$Y = 0 \quad u = 0, \quad v = 0, \quad \frac{\partial p}{\partial y} = \frac{1}{Re} \frac{\partial^2 v}{\partial y^2} + G_x \cdot \sinh \psi \frac{\partial \psi}{\partial y},$$

$$\psi = C_3, \quad \frac{\partial \phi}{\partial y} = 0$$

$$Y = W \quad u = 0, \quad v = 0, \quad \frac{\partial p}{\partial y} = \frac{1}{Re} \frac{\partial^2 v}{\partial y^2} + G_x \cdot \sinh \psi \frac{\partial \psi}{\partial y},$$

$$\psi = C_4, \quad \frac{\partial \phi}{\partial y} = 0,$$

where C_1, C_2, C_3 , and C_4 are known constants.

[0140] The micropump transports fluid onto the sensor array through a parallel microchannel structure as shown in FIG. 34. The functionalized microcantilevers within the microconduits are deflected by predetermined compositions, thereby operating to provide a predetermined chemical analysis of the fluid.

[0141] The design of the force-sensing prosthetic joint components using wireless sensor and telemetry technology is a major advancement for the orthopaedic and CADs industries. An exemplary sensor array includes numerous sensors oriented in a triangular fashion to measure lateral and medial condylar reaction forces, total reaction forces, and the difference in reaction forces between medial and lateral aspects of the permanent or trial prosthetic component. The sensors include a capacitive readout and power for the telemetry is provided inductively. The power can be supplied either by a coil worn near the knee during testing or a small rechargeable battery is incorporated into this system so that the rechargeable battery is charged inductively prior to testing. Alternatively, a piezoelectric sensor providing an output charge may be utilized to power the system dependent upon the dynamic load available to the sensor. This charge in certain instances is sufficient power the telemetry system and recharge any electrical components used for the telemetry system.

[0142] The present invention may be utilized to correct ligament balancing in the knee joint during the time of surgery utilizing readings gathered from trial and permanent prosthetic components. In addition, utilizing the present invention to measure the loads, to measure the symmetry of

the loads at the femorotibial interface in a knee replacement, and to measure the composition of the synovial fluid intra-operatively allows a physician to greatly enhance ligament balancing and inhibiting premature wear of the prosthetic. The present invention may also be utilized to detect bearing surface forces that, in turn, may be used to determine active muscle forces, such as the quadriceps muscle, and/or resistive force, such as ligament forces that provide constraint to the knee joint.

[0143] For example, if abnormal polyethylene levels are detected and the loading conditions within the joint are known it might be possible to correct the imbalances and reverse or decrease wear. If metal debris is detected, wear-through of the insert or excessive corrosion or wear from the Morse taper junctions in modular implants is detected, an appropriate intervention may be performed.

[0144] It is also within the scope of the invention that the sensors and control electronics be incorporated into other prosthetic components including, without limitation, femoral cup prostheses, femoral cup insert prosthesis, femoral stem prosthesis, and other joint replacement components. Those of ordinary skill will readily understand how to adapt the exemplary teachings recited herein to fabricate and use variations such as those discussed above. Moreover, the exemplary teachings of the instant invention are likewise applicable to prosthetic trail components in order to at least sense pressure to facilitate proper biomechanical operation of the prosthetic joint once implanted. Moreover the exemplary teachings are applicable to fixed bearing and mobile bearing prosthetic implants.

[0145] It is also within the scope of the invention that the microsensors and control electronics are incorporated into prosthetic braces to gauge pressures exerted against the brace as a manner to evaluate the effectiveness of the brace and whether the mammalian body part being braced is becoming stronger and/or whether the force distribution against the brace is within predetermined tolerances, tending to show proper biomechanical function.

[0146] It is further within the scope of the instant invention that the sensors and control electronics are responsive in nature in order to automatically prompt the recipient of the prosthesis that one or more monitored conditions is outside of the predetermined range, thereby requiring consultation with the surgeon or attending physician. By way of example, and not limitation, the prosthetic joint may incorporate a wobble insert that would be activated and thereby vibrate when one of more monitored conditions is outside of the normal parameters. Other exemplary methods of actively communicating with the recipient include direct communication to a remote device 91 given to the recipient that would self-diagnose the condition and request the patient to consult the surgeon or attending physician.

[0147] For purposes of the instant invention, microchannel includes those conduits having diameters or restrictive dimensions of 0.1 mm or less, and microsensors include those sensors having dominant dimensions generally less than 1000 μm , and certainly those having dominant dimensions less than 100 μm .

[0148] Following from the above description and invention summaries, it should be apparent to those of ordinary skill in the art that, while the subject matter described herein constitutes exemplary teachings of the present invention, the invention contained herein is not limited to these precise teachings and changes may be made to the aforementioned teachings

without departing from the scope of the invention as defined by the claims. Additionally, it is to be understood that the invention is defined by the claims and it is not intended that any limitations or elements describing the exemplary embodiments set forth herein are to be incorporated into the interpretation of any claim element unless such limitation or element is explicitly stated. Likewise, it is to be understood that it is not necessary to meet any or all of the identified advantages or objects of the invention disclosed herein in order to fall within the scope of any one of the claims, since the invention is defined by the claims and since inherent and/or unforeseen advantages of the present invention may exist even though they may not have been explicitly discussed herein.

1. A method of monitoring a prosthetic implant and its host mammalian body, the method comprising the steps of: implanting a sensor array into the mammalian body, the sensor array mounted to a prosthesis also implanted into the mammalian body; sensing pressure applied to the prosthesis in at least two axes generally perpendicular to one another; generating signals responsive to the sensed pressure applied to the prosthesis by another object; and wirelessly transmitting signals to a remote receiver outside of the mammalian body, the transmitted signals being representative of signals generated by the sensor array in response to sensing the pressure.

2. The method of claim 1, wherein the prosthesis includes at least one of a knee replacement femoral prosthesis, a knee replacement tibial prosthesis, a knee replacement tibial tray prosthesis, a hip replacement femoral prosthesis, a hip replacement acetabular cup prosthesis, a hip replacement acetabular cup insert prosthesis, a trial knee replacement femoral prosthesis, a trial knee replacement tibial prosthesis, a trial knee replacement tibial tray prosthesis, a trial hip replacement femoral prosthesis, a trial hip replacement acetabular cup prosthesis, and a trial hip replacement acetabular cup insert prosthesis.

3. The method of claim 1, further comprising the step of filtering out low frequency noise from the generated signals prior to the wirelessly transmitting step.

4. The method of claim 1, further comprising the step of amplifying the generated signals prior to the wirelessly transmitting step.

5. The method of claim 1, further comprising the step of multiplexing the generated signals prior to the wirelessly transmitting step.

6. The method of claim 1, further comprising the step of converting the generated signals from analog to digital prior to the wirelessly transmitting step.

7. The method of claim 1, further comprising the step of processing the generated signals prior to the wirelessly transmitting step.

8. The method of claim 1, wherein the step of sensing the condition includes sensing at least one of pressure and temperature.

9. The method of claim 1, wherein the step of sensing the condition includes utilizing at least one of a microcantilever and a microcapacitor.

10. The method of claim 1, wherein the step of sensing the condition includes sensing for markers of infection.

11. The method of claim 1, wherein the step of sensing the condition includes encapsulated sensors responsive to pressure changes.

12. The method of claim 1, wherein the step of sensing the condition includes sensors in fluid communication with bodily fluids bathing the prosthesis.

13. The method of claim 1, further comprising: displaying visual representations of the data generated by or during the processing step; and responding to the displayed visual representations to take appropriate corrective action where applicable.

14. The method of claim 1, wherein the step of sensing the condition includes the use of encapsulated sensors responsive to pressure changes.

15. The method of claim 1, wherein the step of sensing the condition includes sensing at least one of: leukocyte concentration, neutrophil concentration, bacterial deoxyribonucleic acid concentration, antibody concentration, glucose concentration, excitatory amino acids concentration, lactate dehydrogenase concentration, hyaluronic acid concentration, uric acid concentration, calcium pyrophosphate concentration, beta-glucuronidase concentration, nerve growth factor concentration, insulin-like growth factor concentration, Caeruloplasmin concentration, and oxidase concentration.

16. The method of claim 1, further comprising processing the transmitted signals by the remote receiver to generate data representative of the sensed pressure.

* * * * *

专利名称(译)	智能关节植入传感器		
公开(公告)号	US20150051455A1	公开(公告)日	2015-02-19
申请号	US14/530915	申请日	2014-11-03
[标]申请(专利权)人(译)	齐默尔股份公司		
申请(专利权)人(译)	ZIMMER , INC.		
当前申请(专利权)人(译)	ZIMMER , INC.		
[标]发明人	WASIELEWSKI RAY C KOMISTEK RICHARD D MAHFOUZ MOHAMED R		
发明人	WASIELEWSKI, RAY C. KOMISTEK, RICHARD D. MAHFOUZ, MOHAMED R.		
IPC分类号	A61B5/00 A61B5/145 A61B5/01		
CPC分类号	A61B5/4851 A61B5/01 A61B5/0002 A61B5/742 A61B5/14507 A61B5/03 A61B5/076 A61B5/145 A61B5/14532 A61B5/14539 A61B5/4528 A61B2562/028 A61F2/38 A61F2/3859 A61F2/389 A61F2/4657 A61F2/4684 A61F2002/30133 A61F2002/3067 A61F2002/30673 A61F2002/30878 A61F2002/4632 A61F2002/4666 A61F2002/488 A61F2230/0015 A61F2250/0002 A61L27/50 G06F19/3418 G16H40/20 G16H40/67 G16H40/63		
其他公开文献	US20180140251A9 US10531826		
外部链接	Espacenet USPTO		

摘要(译)

一种用于植入哺乳动物体内的假体，该装置包括：(a) 用于植入哺乳动物体内的假体，其包括传感器阵列，该传感器阵列包括安装在假体上的多个传感器；(b) 用于接收来自传感器阵列的信号并将代表信号无线传输到远程接收器的电子结构，其中多个传感器可操作以感测由另一物体施加到假体上的压力，在至少两个轴上大致垂直彼此。

A prosthesis for implantation into a mammalian body, the device comprising: (a) a prosthesis for implantation into a mammalian body that includes a sensor array comprising a plurality of sensors mounted to the prosthesis; and (b) an electronics structure for receiving signals from the sensor array and wirelessly transmitting representative signals to a remote receiver, where the plurality of sensors are operative to sense pressure, applied to the prosthesis by another object, in at least two axes generally perpendicular to one another.