



US 20140018657A1

(19) **United States**

(12) **Patent Application Publication**
Sharma

(10) **Pub. No.: US 2014/0018657 A1**
(43) **Pub. Date: Jan. 16, 2014**

(54) **DEVICE AND IMPLANTATION SYSTEM FOR ELECTRICAL STIMULATION OF BIOLOGICAL SYSTEMS**

Publication Classification

(71) Applicant: **Endostim, Inc.**, St. Louis, MO (US)

(51) **Int. Cl.**
A61B 5/00 (2006.01)
A61N 1/05 (2006.01)

(72) Inventor: **Virender K. Sharma**, Paradise Valley, AZ (US)

(52) **U.S. Cl.**
CPC *A61B 5/6879* (2013.01); *A61N 1/0502* (2013.01)

(73) Assignee: **Endostim, Inc.**, St. Louis, MO (US)

USPC **600/377; 607/116**

(21) Appl. No.: **13/934,040**

(57) **ABSTRACT**

(22) Filed: **Jul. 2, 2013**

An implantable stimulation device for use in stimulation based treatments for diseases such as GERD or obesity is described. The device is provided with an anchoring unit which upon deployment assumes a shape optimized for the site of deployment. Sensing electrodes and stimulating electrodes in the device are also designed to assume a suitable shape upon deployment. A novel catheter is also provided for easy and expeditious deployment of the device.

Related U.S. Application Data

(63) Continuation of application No. 12/359,317, filed on Jan. 25, 2009, now Pat. No. 8,543,210.

(60) Provisional application No. 61/023,535, filed on Jan. 25, 2008.

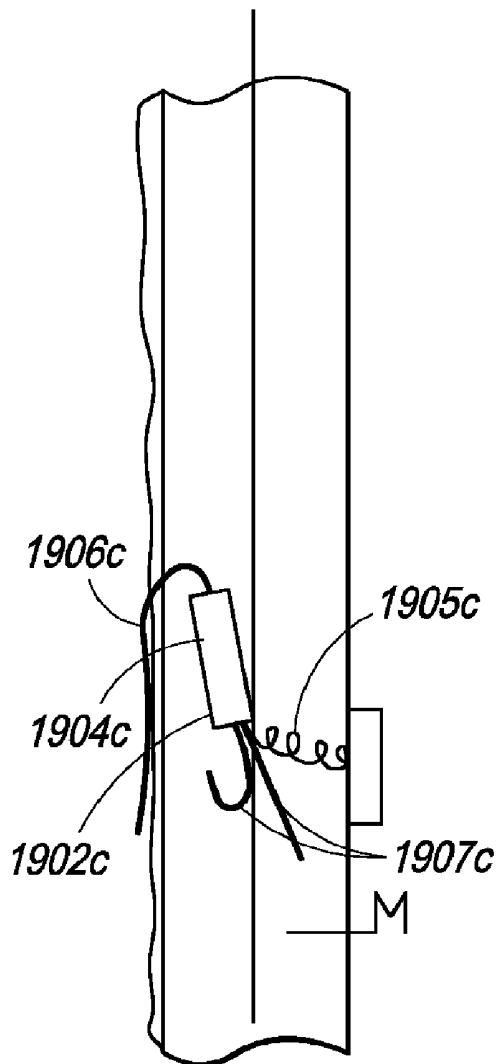

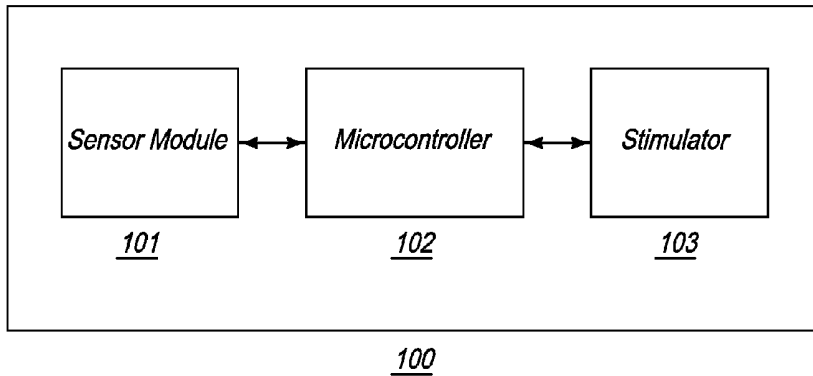

FIG. 1

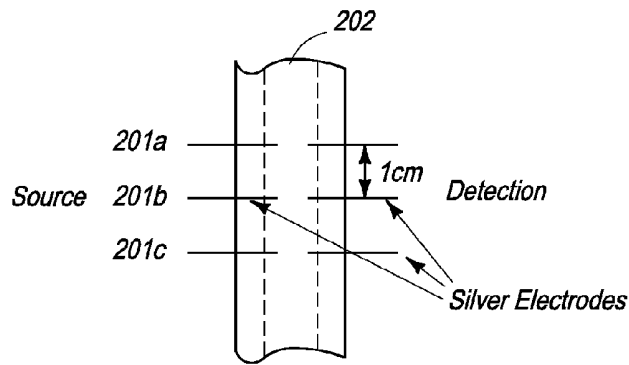

FIG. 2

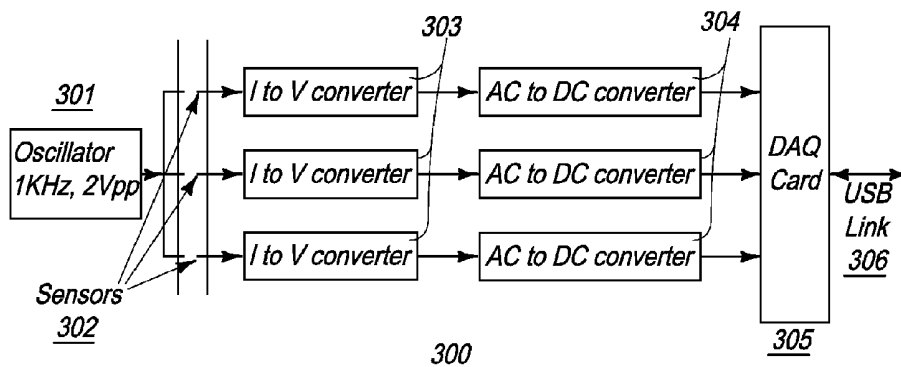

FIG. 3

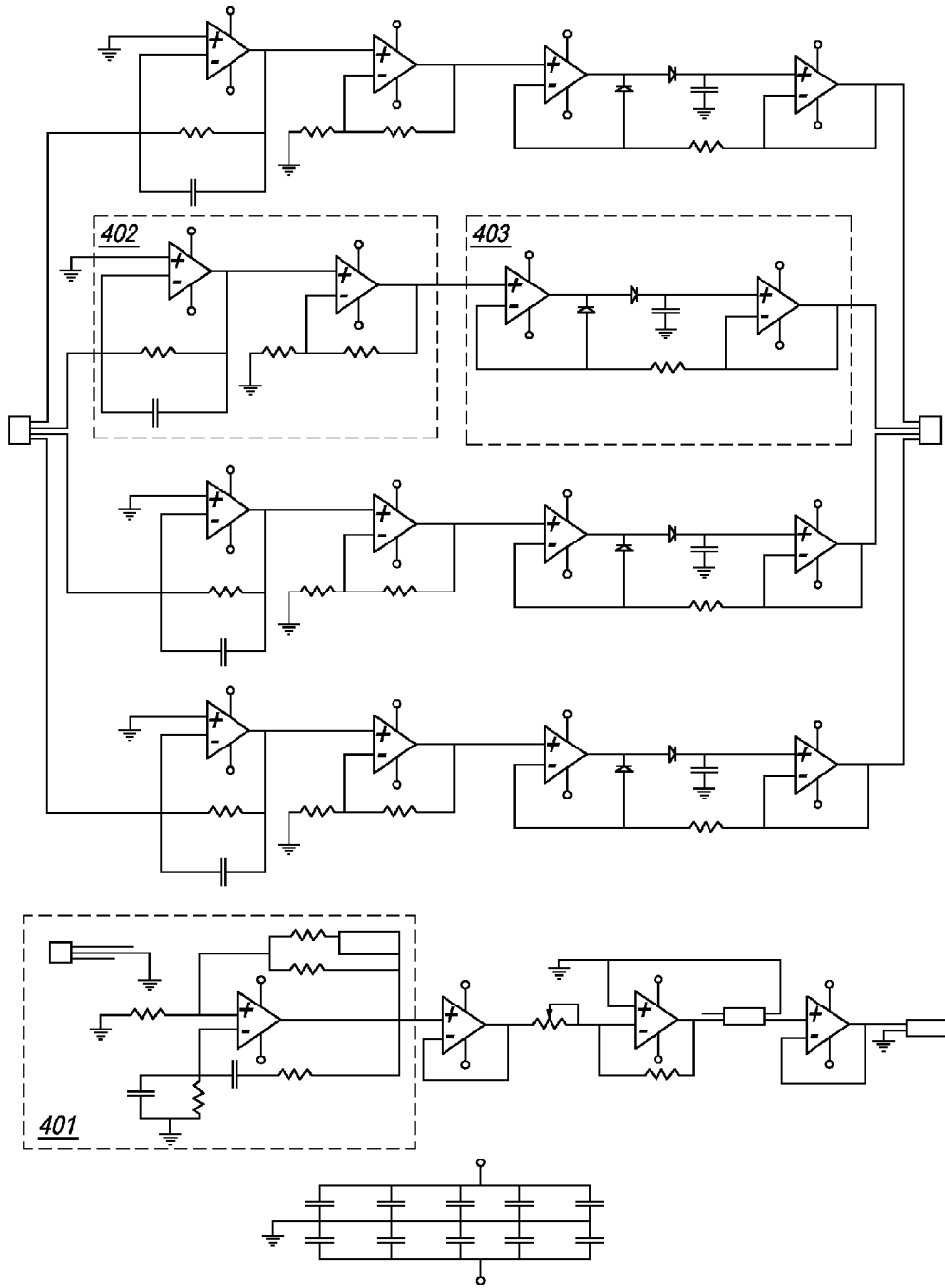

FIG. 4

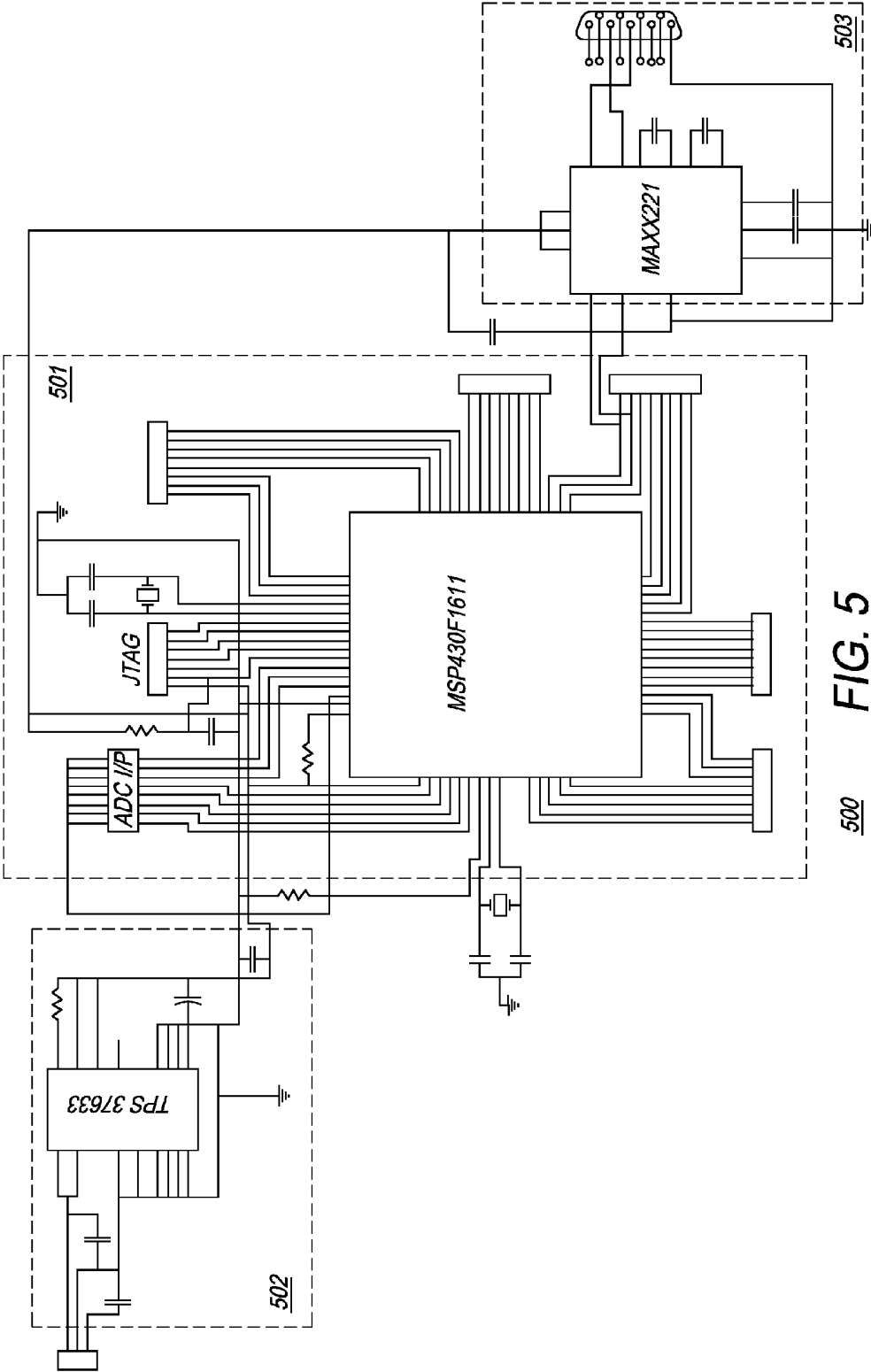

FIG. 5

500

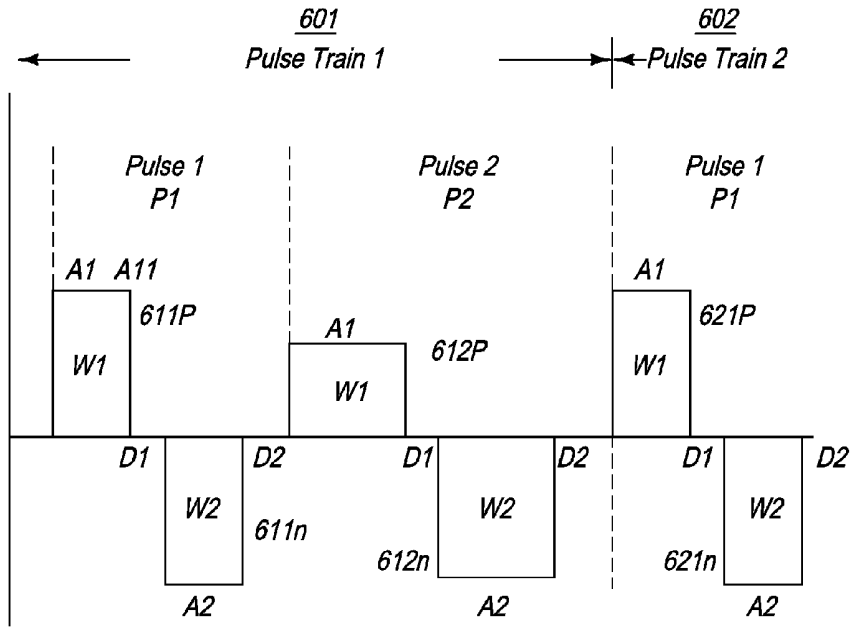

FIG. 6

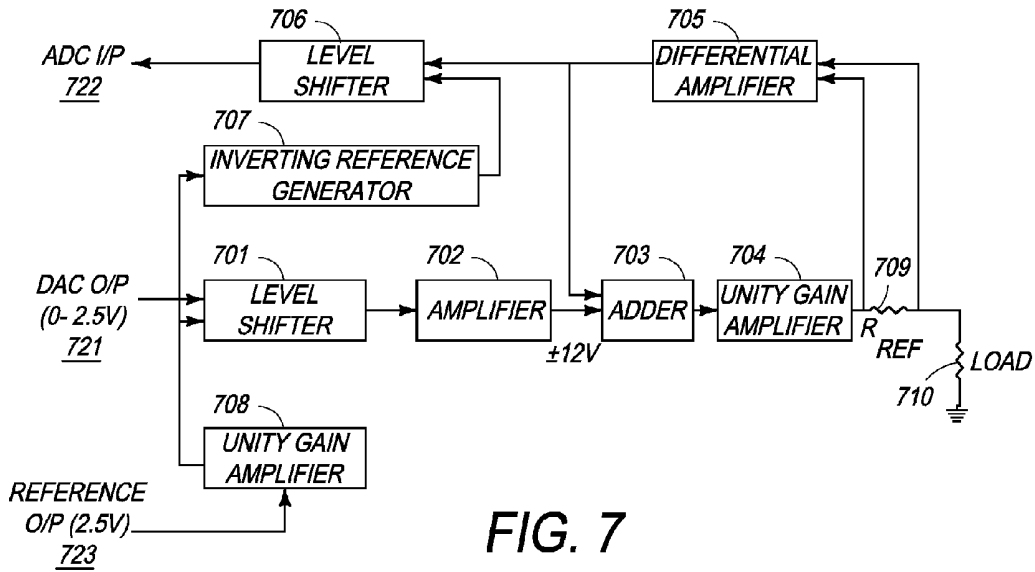

FIG. 7

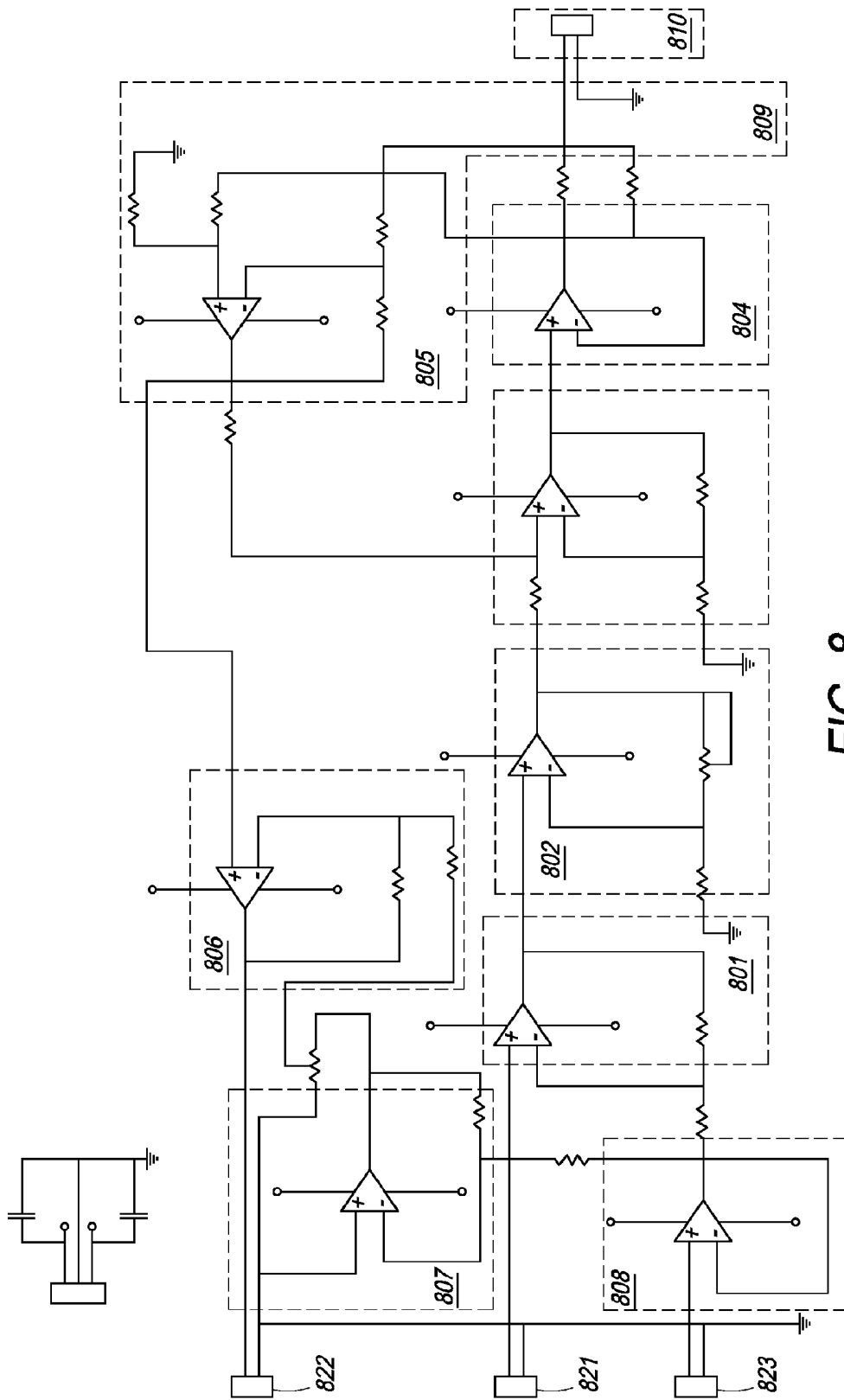

FIG. 8

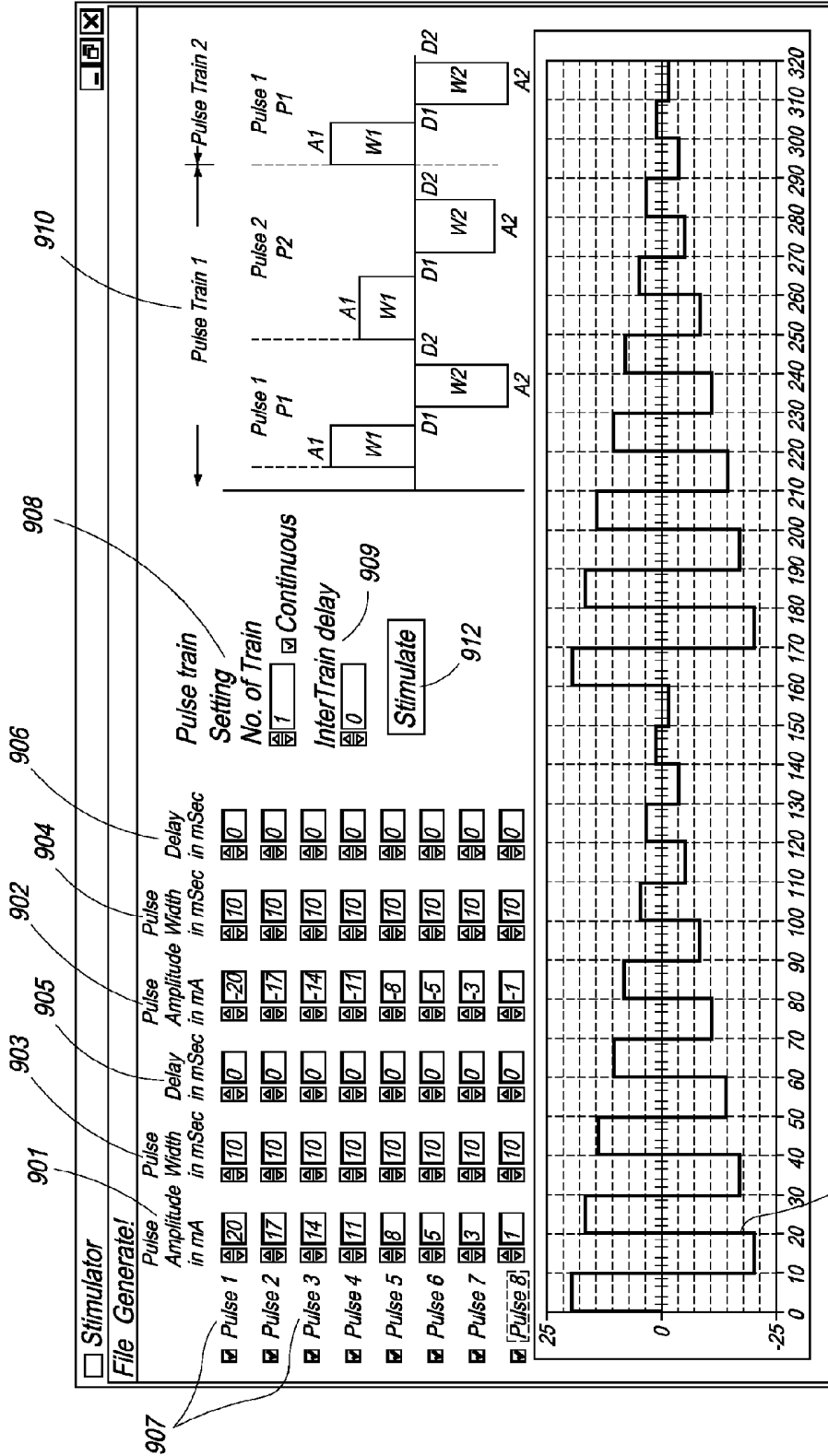

FIG. 9

900

911

907

901

903

905

904

906

908

910

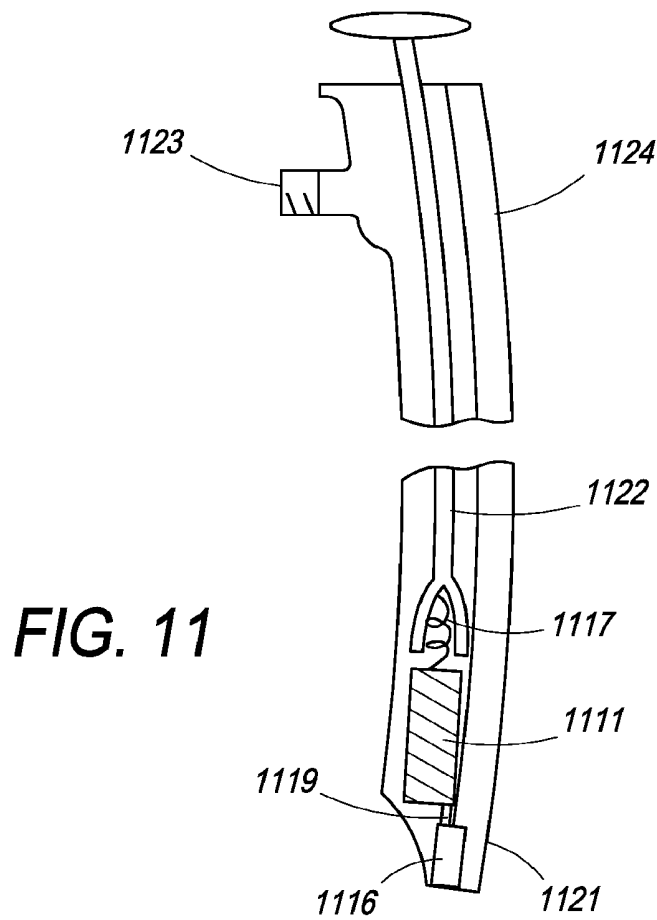
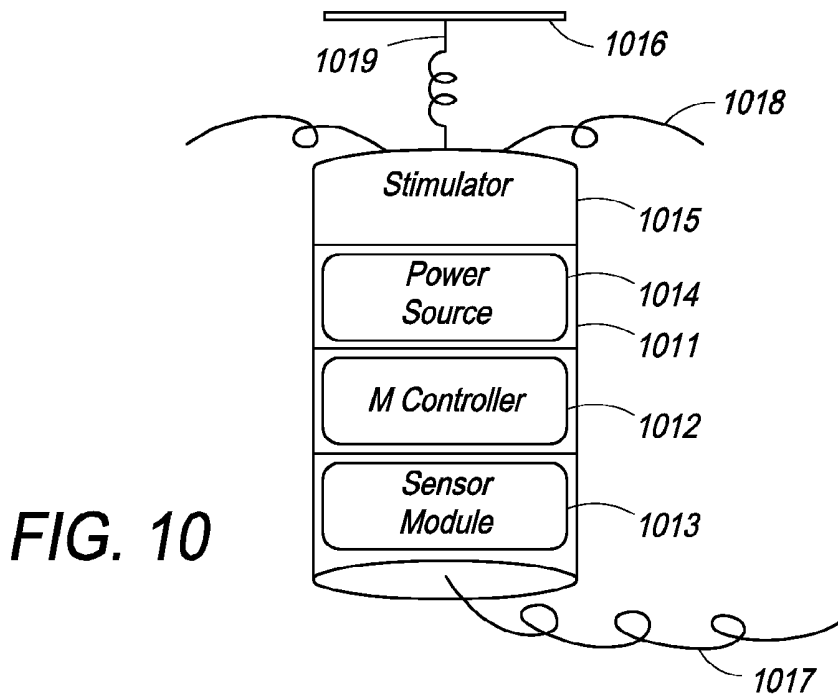

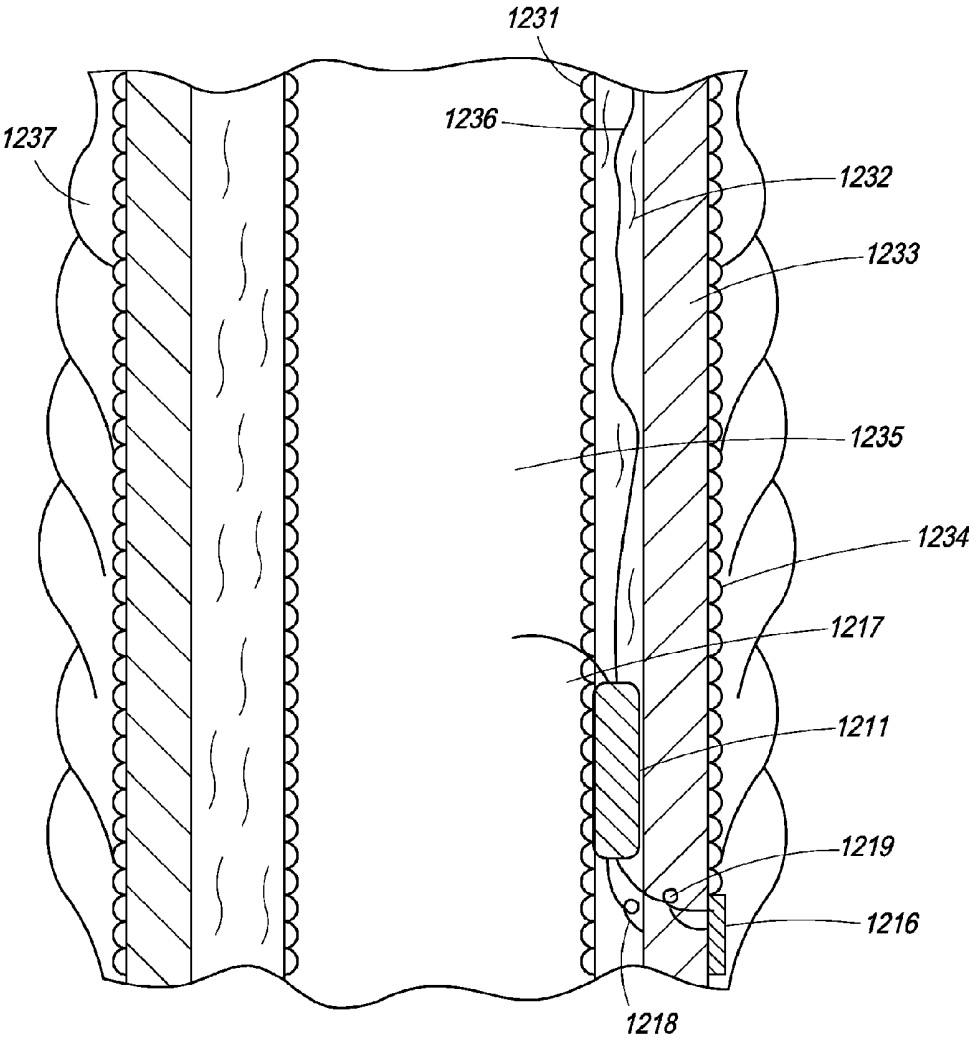

FIG. 12

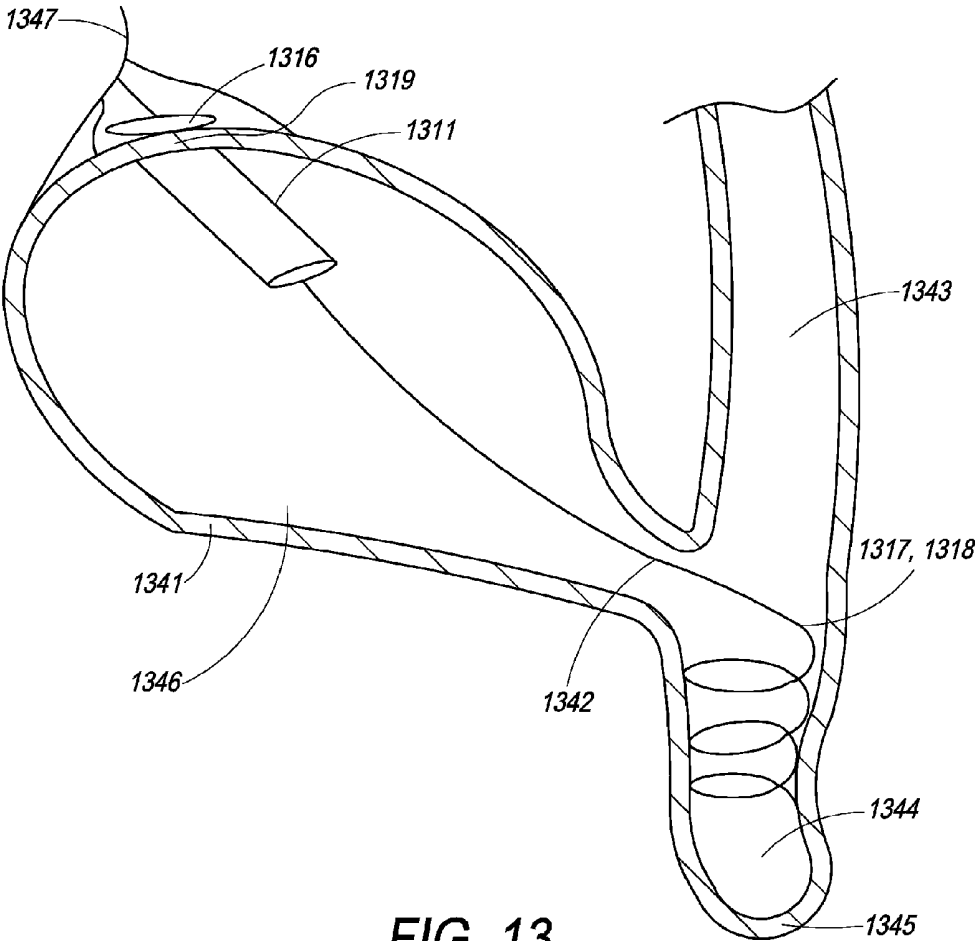

FIG. 13

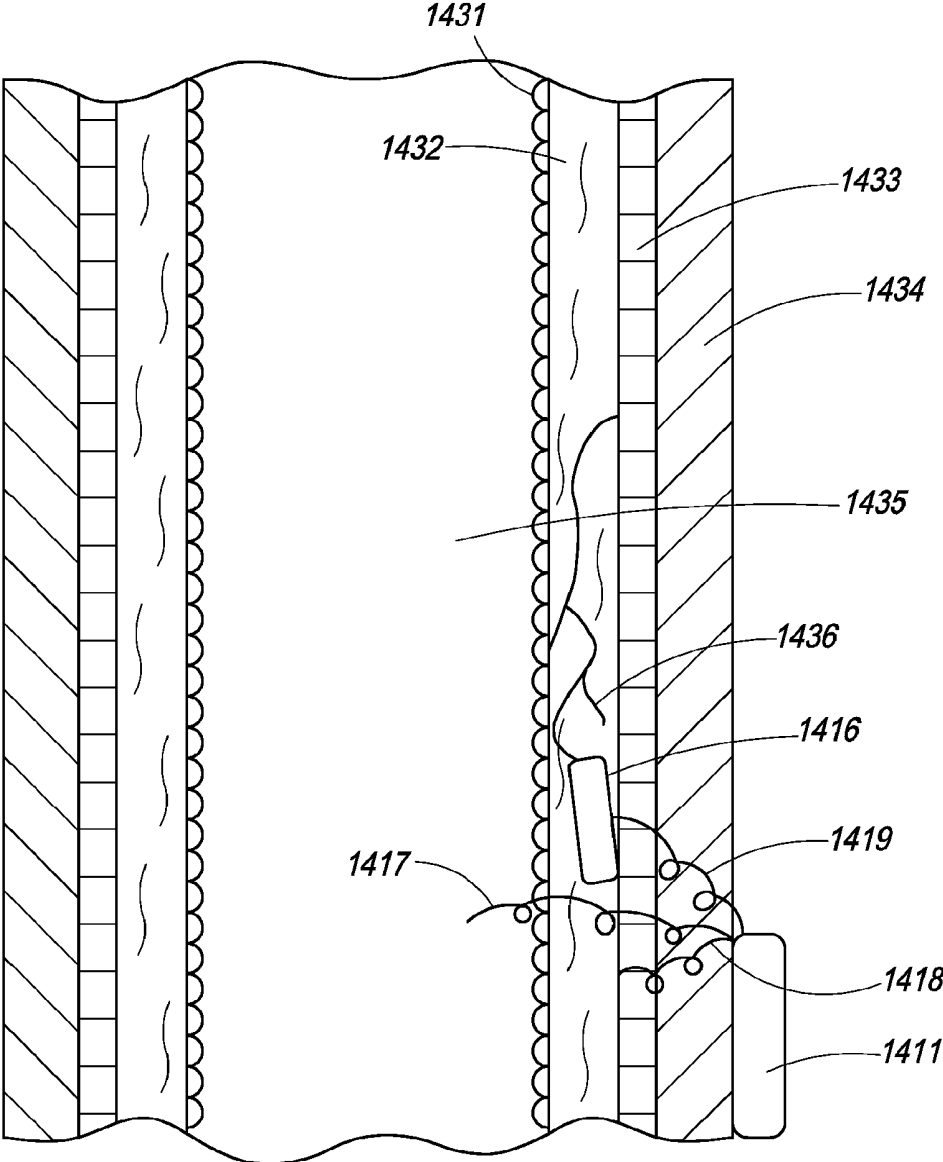

FIG. 14

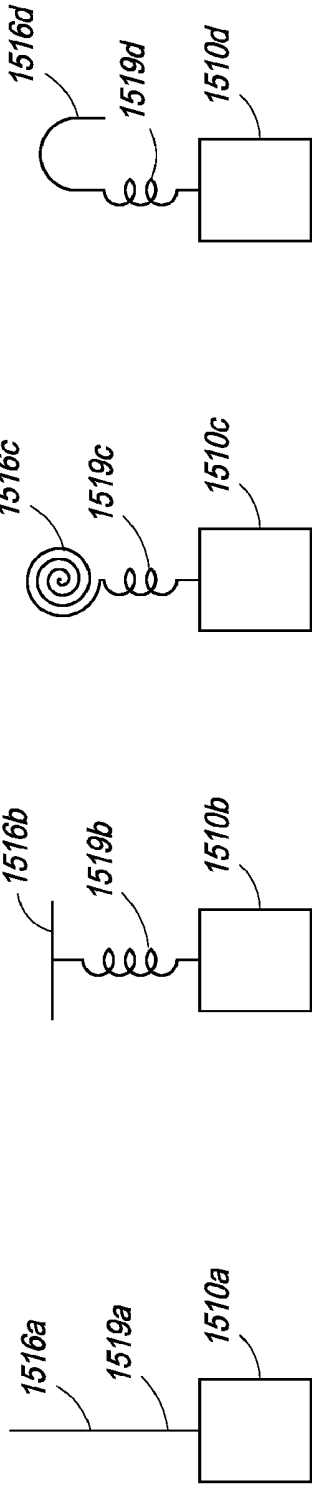

FIG. 15a

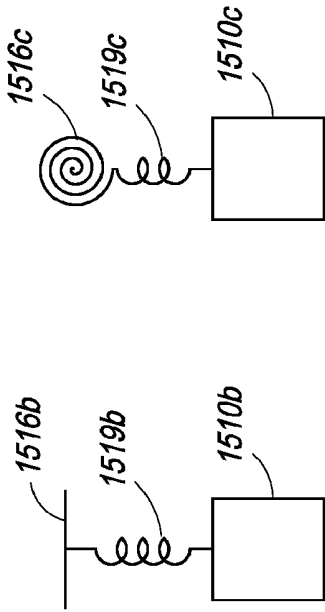

FIG. 15b

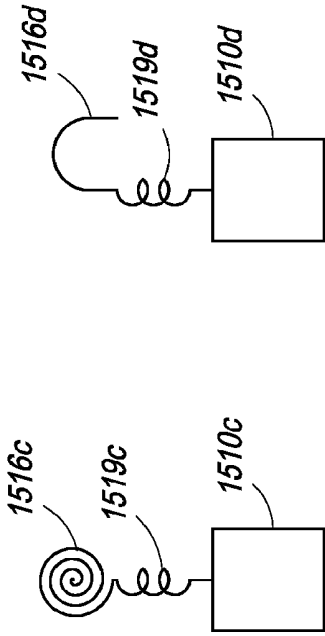

FIG. 15c

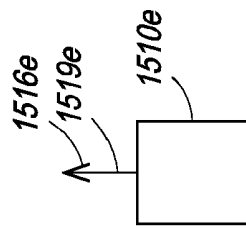

FIG. 15e

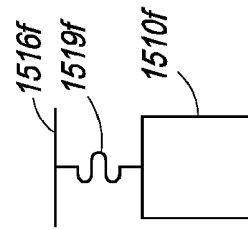

FIG. 15f

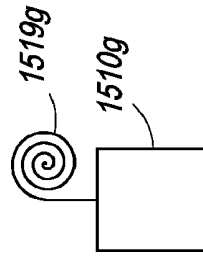

FIG. 15g

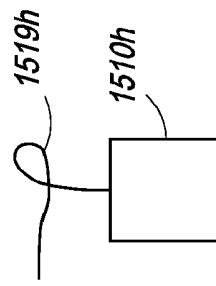
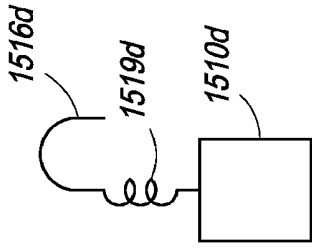

FIG. 15h

FIG. 15d



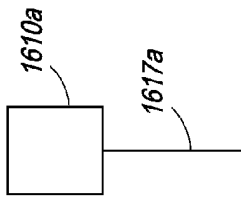

FIG. 16a

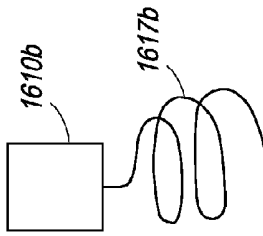

FIG. 16b

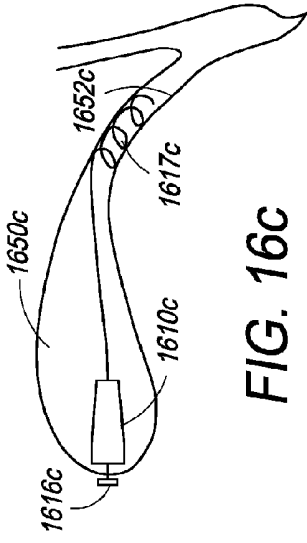

FIG. 16c

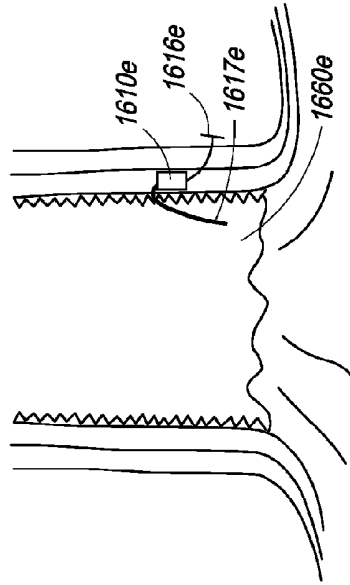

FIG. 16d

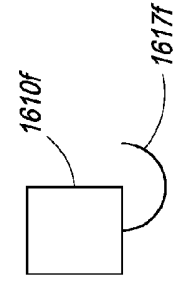

FIG. 16f

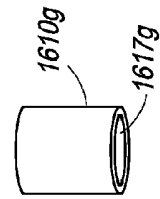

FIG. 16g

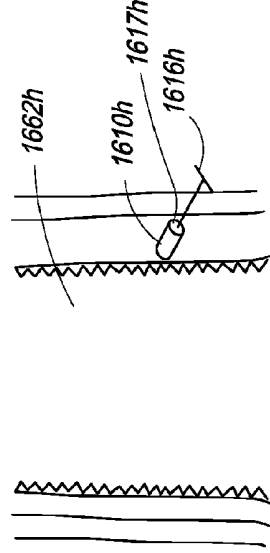

FIG. 16h

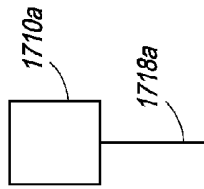

FIG. 17a

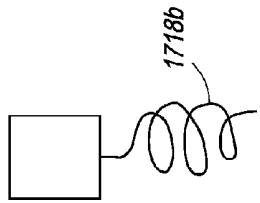

FIG. 17b

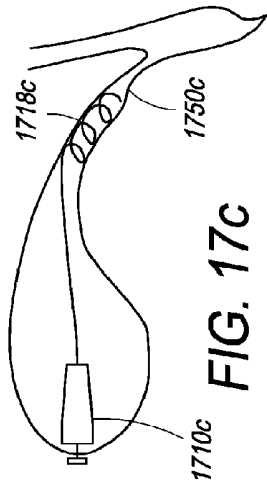

FIG. 17c

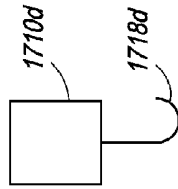

FIG. 17d

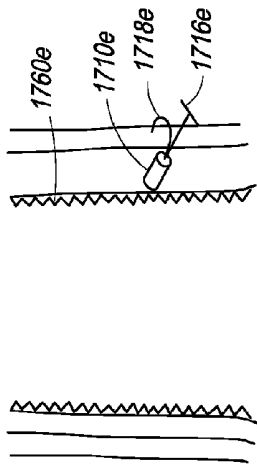

FIG. 17e

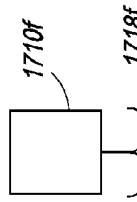

FIG. 17f

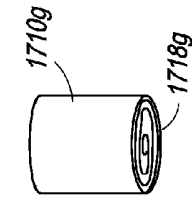

FIG. 17g

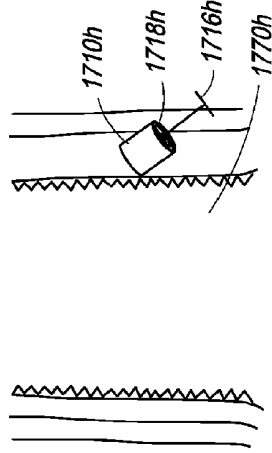

FIG. 17h

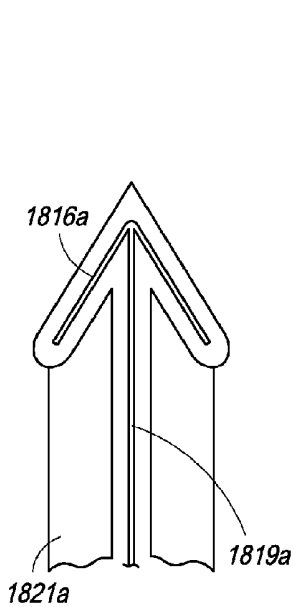

FIG. 18a

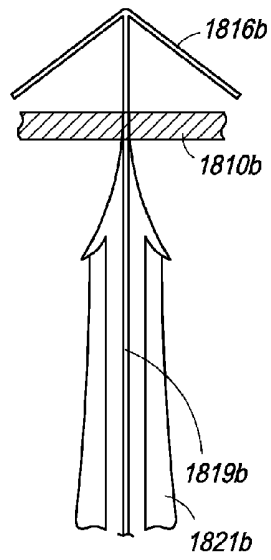

FIG. 18b

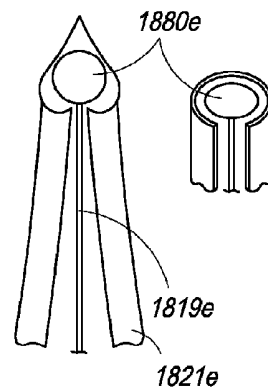

FIG. 18e

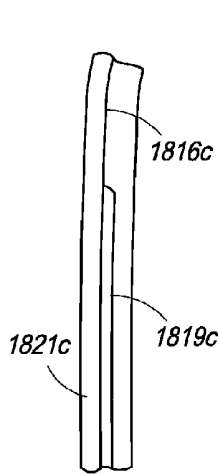

FIG. 18c

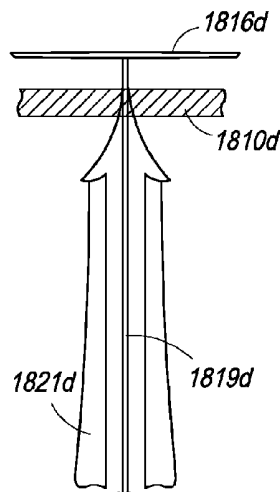

FIG. 18d

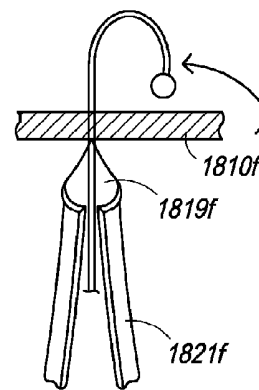

FIG. 18f

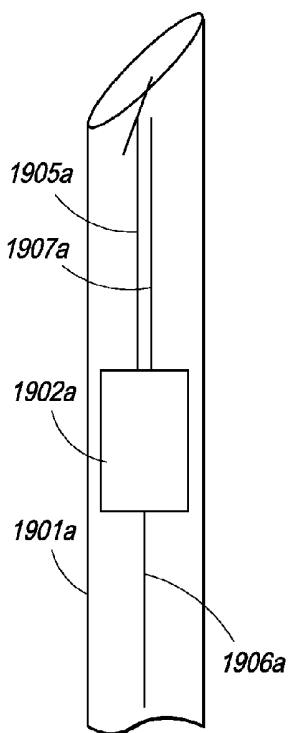

FIG. 19a

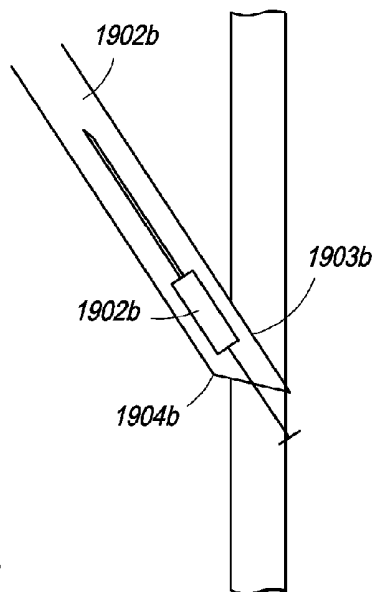

FIG. 19b

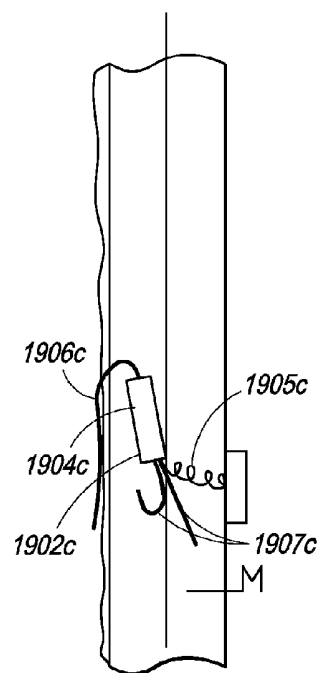

FIG. 19c

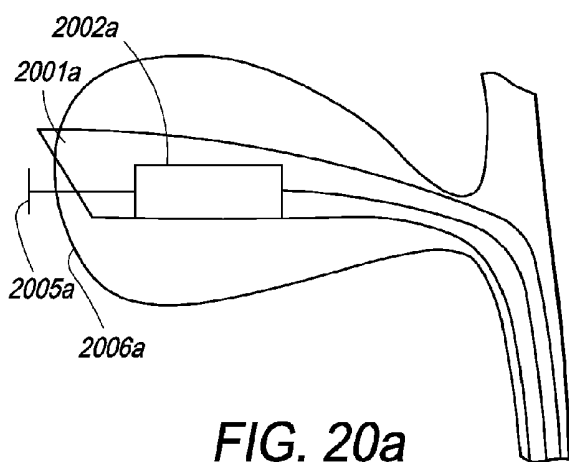

FIG. 20a

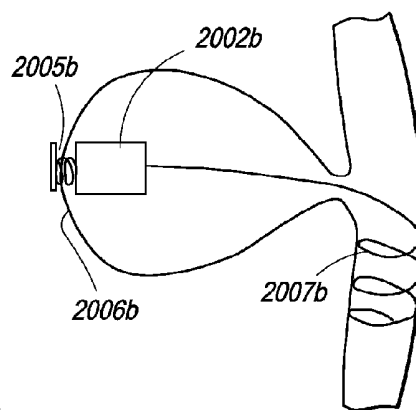

FIG. 20b

**DEVICE AND IMPLANTATION SYSTEM FOR
ELECTRICAL STIMULATION OF
BIOLOGICAL SYSTEMS**

CROSS REFERENCE

[0001] This application relates on U.S. Provisional Application No. 61/023,535 for priority and is herein incorporated by reference.

FIELD OF THE INVENTION

[0002] This invention relates generally to a method and apparatus for electrical stimulation of the biological systems. More particularly, this invention relates to a method and apparatus for treating a condition by electrically stimulating a portion of the gastrointestinal system.

BACKGROUND OF THE INVENTION

[0003] Gastro-esophageal reflux disease (GERD) is a common problem and is expensive to manage in both primary and secondary care settings. This condition results from exposure of esophageal mucosa to gastric acid as the acid refluxes from the stomach into the esophagus. The acid damages the esophageal mucosa resulting in heartburn, ulcers, bleeding, and scarring, and long term complications such as Barrett's esophagus (pre-cancerous esophageal lining) and adenocarcinoma of the esophagus. Transient relaxation of the lower esophageal sphincter (LES) is believed to be the primary mechanism of the disease although the underlying cause remains uncertain.

[0004] Lifestyle advice and antacid therapy is advocated as first line treatment for the disease. However since most patients with moderate to severe cases of GERD do not respond adequately to these first-line measures and need further treatment, therefore other alternatives including pharmacological, endoscopic, and surgical treatments are employed.

[0005] The most commonly employed pharmacological treatment is daily use of H₂ receptor antagonists (H₂RAs) or proton-pump inhibitors (PPIs) for acid suppression. Since gastro-esophageal reflux disease usually relapses once drug therapy is discontinued, most patients with the disease, therefore, need long-term drug therapy. However, daily use of PPIs or H₂RAs is not universally effective in the relief of GERD symptoms or as maintenance therapy. Additionally, not all patients are comfortable with the concept of having to take daily or intermittent medication for the rest of their lives and many are interested in nonpharmacological options for managing their reflux disease.

[0006] Several endoscopic procedures for the treatment of GERD are being tried. These procedures can be divided into three approaches—endoscopic suturing where stitches are inserted in the gastric cardia to plicate and strengthen the lower esophageal sphincter; the endoscopic application of radio-frequency to the lower esophagus; and the injection of bulking agents into the muscle layer of the distal esophagus. These procedures, however, are not without their risks, besides being technically demanding and involving a long procedure time. As a result, these procedures have largely been discontinued.

[0007] Open surgical or laparoscopic fundoplication is also used to correct the cause of the disease. However, surgical procedures suffer from the disadvantages that they are associated with significant morbidity and small but finite mortality. Moreover, long-term follow-up with patients treated by

surgery suggests that many patients continue to need acid suppressive medication. There is also no convincing evidence that fundoplication reduces the risk of esophageal adenocarcinoma in the long term.

[0008] Besides GERD, obesity is a common condition and a major public health problem in developed nations including the United States of America. Today, 64.5% of American adults, about 127 million people, are either overweight or obese. Data suggest that 300,000 Americans die prematurely from obesity-related complications each year. Many children are overweight or obese in the United States; hence, the steady increase in the number of overweight Americans is expected to continue. It has been estimated that obesity costs the United States approximately \$100 billion annually in direct and indirect health care expenses and in lost productivity. This trend is also apparent in many other developed countries.

[0009] Morbid obesity is defined as possessing either a body weight more than 100 pounds greater than normal or a body mass index (BMI) greater than 40 kg/m². Approximately 5% of the U.S. population meets at least one of these definitions. A BMI greater than 30 kg/m² is associated with significant co-morbidities. Morbid obesity is associated with many diseases and disorders including, for example, diabetes, hypertension, heart attacks, strokes, dyslipidemia, sleep apnea, Pickwickian Syndrome, asthma, lower back and disc disease, weight-bearing osteo-arthritis of the hips, knees, ankles and feet, thrombophlebitis and pulmonary emboli, intertriginous dermatitis, urinary stress incontinence, gastroesophageal reflux disease (GERD), gallstones, and sclerosis and carcinoma of the liver. In women, infertility, cancer of the uterus, and cancer of the breast are also associated with morbid obesity. Taken together, the diseases associated with morbid obesity markedly reduce the odds of attaining an average lifespan and raise annual mortality in affected people by a factor of 10 or more.

[0010] Current treatments for obesity include diet, exercise, behavioral treatments, medications, surgery (open and laparoscopic) and endoscopic devices. Also, additional treatments for obesity are currently being evaluated in drug clinical trials. However, a high efficacy pharmaceutical treatment has not yet been developed. Further, short-term and long-term side effects of pharmaceutical treatments may concern consumers, pharmaceutical providers, and/or their insurers. Generally, diet or drug therapy programs have been consistently disappointing and fail to bring about significant, sustained weight loss in the majority of morbidly obese people.

[0011] Currently, most morbid obesity operations are, or include, gastric restrictive procedures, involving the creation of a small (e.g., 15-35 mL) upper gastric pouch that drains through a small outlet (e.g., 0.75-1.2 cm), setting in motion the body's satiety mechanism. About 15% of morbid obesity operations done in the United States involve gastric restrictive surgery combined with a malabsorptive procedure. Typical malabsorptive procedures divide small intestinal flow into a biliary-pancreatic conduit and a food conduit. Potential long-term problems with surgical procedures, including those seen after any abdominal procedure, are notorious and can include, for example, ventral hernia and small bowel obstruction. In addition, long-term problems specific to bariatric procedures can include, for example, gastric outlet obstruction, marginal ulceration, protein malnutrition, and vitamin deficiency.

[0012] Other surgical strategies for treating obesity include endoscopic procedures, many of which are still in develop-

ment. Endoscopically placed gastric balloons restrict gastric volume and result in satiety with smaller meals. Endoscopic procedures and devices to produce gastric pouch and gastrojejunal anastomosis to replicate laparoscopic procedures are also in development. These procedures, however, are not without risks.

[0013] Gastric electric stimulation (GES) is another procedure that is currently in clinical trial. GES employs an implantable, pacemaker-like device to deliver low-level electrical stimulation to the stomach. The procedure involves the surgeon suturing electrical leads to the outer lining of the stomach wall. The leads are then connected to the device, which is implanted just under the skin in the abdomen. Using an external programmer that communicates with the device, the surgeon establishes the level of electrical stimulation appropriate for the patient. The Transcend® implantable gastric stimulation device, manufactured by Transneuronix Corporation, is currently available in Europe for treatment of obesity.

[0014] In another example, Medtronic offers for sale and use the Enterra™ Therapy, which is indicated for the treatment of chronic nausea and vomiting associated with gastroparesis when conventional drug therapies are not effective. The Enterra™ Therapy uses mild electrical pulses to stimulate the stomach. According to Medtronic, this electrical stimulation helps control the symptoms associated with gastroparesis including nausea and vomiting.

[0015] U.S. Pat. No. 6,901,295, issued to the inventor, describes an implantable apparatus for electrical stimulation of the lower esophageal sphincter (LES). It relies on sensing certain physiological changes in the esophagus, such as changes in esophageal pH, to detect acid reflux, which is required for generating electrical stimulation in order to abort the episode of acid reflux through the LES into the esophagus. pH sensing is conventionally used to detect GERD, in the form of a 24 hour pH test. Additionally impedance pH testing is also used to detect GERD and using pattern recognition, pH of the refluxate could be assessed using impedance pH testing.

[0016] There is still a need for a safe and effective method of treatment that can help alleviate symptoms of GERD in the long term, without adversely affecting the quality of life of the patients. In addition, there is still a need for minimally invasive and effective treatment for obesity. Moreover, there is not only a need for better devices in stimulation based therapies, but there is also a need for a safe and minimally invasive method and system that enables easy and expeditious deployment of such devices at any desired location in the body. Most of the currently available devices are available for surgical or laparoscopic implantation and suffer from common problem of pocket infection, lead dislodgment or fracture.

[0017] Furthermore, there is still a need for a device and method for implanting microstimulator devices within the gastrointestinal system. Stimulators are typically implanted surgically. U.S. Pat. Nos. 7,076,305 and 7,016,735 disclose an implantable device for electrically stimulating the stomach wall to cause gastric motility or otherwise treat gastrointestinal related disorders. The device is implanted using an endoscope. As designed, deployment can only occur in the stomach lumen and requires the use of a protective overtube for repeated passage of endoscope, passing the device into the stomach and to prevent instruments and devices from inadvertently dropping into the trachea and prevent bacterial contamination which can happen with multiple passes of the

instruments. Overtubes are cumbersome, technically difficult, and associated with complications such as perforation, gastrointestinal wall tears and bleeding.

SUMMARY OF THE INVENTION

[0018] In one embodiment, the present invention is directed to an implantable device for stimulating the smooth muscles or nerves inside the body, comprising a) a stimulator for generating pulses and delivering the generated pulses to said smooth muscles or nerves through a stimulating electrode; b) a sensor module with a sensing electrode for detecting a change in a physiological parameters; c) an anchoring unit attached to said stimulator, wherein said anchoring unit has a pre-deployment shape and a post deployment shape and wherein said post deployment shape is different than the pre-deployment shape; d) a power source; and e) a microcontroller for instructing the stimulator to selectively generate said pulses. The implant site can be in any physical location, including the walls of one or more organs.

[0019] Optionally, the anchoring unit is further used to facilitate puncture at the implant site for deployment of said device. Upon deployment of said device into an implant site, a shape of said anchoring unit changes to a predetermined shape, said predetermined shape being determined according to the implant site. The shape of said anchoring unit changes to any one of a T-bar, a ship anchor, a spiral disc, a hook, a spiral loop, a loop or any freeform shape or non-linear shape capable of anchoring. The device may comprise more than one anchoring unit and said more than one anchoring unit each assume same or different shapes upon deployment. Upon deployment of said device into an implant site, a shape of said sensing electrode may change to a predetermined shape, said predetermined shape being determined according to the implant site. The shape of said sensing electrode changes to any one of a spiral shape, an acute angular shape, or a hook. The sensing electrode or sensor maybe configured as a disk attached to one surface of said device. The shape of said stimulating electrode may change to a predetermined shape, said predetermined shape being determined according to the implant site. The shape of said stimulating electrode changes to any one of a spiral shape, a hook, a double hook or a loop. The stimulating electrode maybe configured as a disk attached to one surface of said device. The anchoring unit maybe used to deliver said stimulus pulses to the nerve or the smooth muscles. The sensing electrode maybe used to deliver said stimulus pulses to the nerve or the smooth muscles as well as to detect changes in physiological parameters of said smooth muscles in response to said stimulus pulses. The anchoring unit may also used to detect changes in physiological parameters of said smooth muscles in response to said stimulus pulses. One electrode unit may comprise the stimulating electrode, the sensing electrode, and the anchoring unit. One or all of these units could be made of shape memory alloys. The physiological parameters include at least one of pH, pressure, peristalsis, temperature, impedance, motion, flow, electrical activity, chemical activity, hormonal activity, muscular activity and neural activity.

[0020] In another embodiment, the present invention is directed to a catheter system for containing, delivering, and implanting a device for stimulating the smooth muscles inside the body, comprising a) a catheter having a housing further comprising a stimulator for generating pulses and delivering the generated pulses to said nerve or smooth muscles through a stimulating electrode, a sensor module

with a sensor or sensing electrode for detecting a change in physiological parameters, a power source, and a microcontroller for instructing the stimulator to selectively generate said pulses; and b) an anchoring unit attached to said stimulator.

[0021] Optionally, the anchoring unit foreshortens upon deployment of said device in the intestinal wall or smooth muscles to pull the device deeper into said intestinal wall or smooth muscles. Upon deployment of said device into an implant site, a shape of said anchoring unit changes to a predetermined shape, said predetermined shape being determined according to the implant site. The shape of said anchoring unit changes to any one of a T-bar, a ship anchor, a spiral disc, a hook, a club, a spiral loop, a loop or any freeform shape capable of anchoring.

BRIEF DESCRIPTION OF THE DRAWINGS

[0022] These and other objects and advantages of the present invention will become more fully apparent from the following detailed description when read in conjunction with the accompanying drawings with like reference numerals indicating corresponding parts through-out, wherein:

[0023] FIG. 1 is an overall block diagram of certain modules of the present invention;

[0024] FIG. 2 is a schematic illustration of an exemplary arrangement of electrodes of the sensor module;

[0025] FIG. 3 is a schematic illustration of the major components comprising the sensor module of the present invention;

[0026] FIG. 4 is a detailed circuit diagram of the sensor module of the present invention;

[0027] FIG. 5 is a detailed circuit diagram of the microcontroller unit of the present invention;

[0028] FIG. 6 is a schematic illustration of an exemplary waveform of pulses generated by the stimulator of the present invention;

[0029] FIG. 7 is a block diagram depicting major components of the stimulator circuit;

[0030] FIG. 8 is a detailed circuit diagram of the stimulator;

[0031] FIG. 9 is a schematic illustration of an exemplary screen shot of the GUI as used with the present invention;

[0032] FIG. 10 illustrates an exemplary embodiment of a microdevice that is used as a stimulation system in one embodiment of the present invention;

[0033] FIG. 11 illustrates an exemplary embodiment of a catheter used for the implantation of the microdevice;

[0034] FIG. 12 illustrates an exemplary embodiment of the microdevice implanted in the submucosa of the gastrointestinal tract;

[0035] FIG. 13 illustrates an exemplary embodiment of the microdevice implanted in the gallbladder lumen;

[0036] FIG. 14 illustrates an exemplary embodiment of the microdevice implanted on the serosal surface of the gastrointestinal tract;

[0037] FIG. 15a illustrates a first exemplary configuration of the anchoring system;

[0038] FIG. 15b illustrates a second exemplary configuration of the anchoring system;

[0039] FIG. 15c illustrates a third exemplary configuration of the anchoring system;

[0040] FIG. 15d illustrates a fourth exemplary configuration of the anchoring system;

[0041] FIG. 15e illustrates a fifth exemplary configuration of the anchoring system;

[0042] FIG. 15f illustrates a sixth exemplary configuration of the anchoring system;

[0043] FIG. 15g illustrates a seventh exemplary configuration of the anchoring system;

[0044] FIG. 15h illustrates an eighth exemplary configuration of the anchoring system;

[0045] FIG. 16a illustrates a first exemplary configuration of the sensing electrode;

[0046] FIG. 16b illustrates a second exemplary configuration of the sensing electrode;

[0047] FIG. 16c illustrates a third exemplary configuration of the sensing electrode;

[0048] FIG. 16d illustrates a fourth exemplary configuration of the sensing electrode;

[0049] FIG. 16e illustrates a fifth exemplary configuration of the sensing electrode;

[0050] FIG. 16f illustrates a sixth exemplary configuration of the sensing electrode;

[0051] FIG. 16g illustrates a seventh exemplary configuration of the sensing electrode;

[0052] FIG. 16h illustrates an eighth exemplary configuration of the sensing electrode;

[0053] FIG. 17a illustrates a first exemplary configuration of the stimulating electrode;

[0054] FIG. 17b illustrates a second exemplary configuration of the stimulating electrode;

[0055] FIG. 17c illustrates a third exemplary configuration of the stimulating electrode;

[0056] FIG. 17d illustrates a fourth exemplary configuration of the stimulating electrode;

[0057] FIG. 17e illustrates a fifth exemplary configuration of the stimulating electrode;

[0058] FIG. 17f illustrates a sixth exemplary configuration of the stimulating electrode;

[0059] FIG. 17g illustrates a seventh exemplary configuration of the stimulating electrode;

[0060] FIG. 17h illustrates an eighth exemplary configuration of the stimulating electrode;

[0061] FIG. 18a illustrates a first exemplary configuration of the anchoring system pre-deployment in the puncture needle;

[0062] FIG. 18b illustrates a first exemplary configuration of the anchoring system post-deployment out of the puncture needle;

[0063] FIG. 18c illustrates a second exemplary configuration of the anchoring system pre-deployment in the puncture needle;

[0064] FIG. 18d illustrates a second exemplary configuration of the anchoring system post-deployment out of the puncture needle;

[0065] FIG. 18e illustrates a third exemplary configuration of the anchoring system pre-deployment in the puncture needle;

[0066] FIG. 18f illustrates a third exemplary configuration of the anchoring system post-deployment out of the puncture needle;

[0067] FIG. 19a illustrates a first step in an exemplary procedure for endoscopic deployment of the device into the LES;

[0068] FIG. 19b illustrates a second step in an exemplary procedure for endoscopic deployment of the device into the LES;

[0069] FIG. 19c illustrates a third step in an exemplary procedure for endoscopic deployment of the device into the LES;

[0070] FIG. 20a illustrates a first step in an exemplary procedure for endoscopic deployment of the device into the gallbladder; and

[0071] FIG. 20b illustrates a second step in an exemplary procedure for endoscopic deployment of the device into the gallbladder.

DETAILED DESCRIPTION OF THE INVENTION

[0072] The present invention is directed toward a novel programmable implantable electro-medical device for the treatment of various neuro-muscular disorders, including gastro-esophageal reflux disease (GERD) and obesity. The electro-medical device of the present invention employs implantable microstimulators that can be implanted with minimal invasiveness in the gastrointestinal system. The stimulation patterns of the device can be altered to treat other conditions such as pancreatico-biliary stimulation or stimulating the lower esophageal sphincter when a person swallows to curtail food intake and thereby treat obesity. It should further be appreciated that the present device is capable of stimulating all smooth muscle, not limited to GI smooth muscles. The present application further incorporates by reference U.S. Pat. No. 6,901,295, PCT/US08/56479, and U.S. patent application Ser. Nos. 12/030,222 and 11/539,645.

[0073] Referring to FIG. 1, an overall block diagram illustrating the major components of the device of the present invention is shown. The device comprises three main units—a sensor module 101, a microcontroller 102 and a stimulator 103. The sensor module 101 comprises electrodes for sensing peristaltic flow, anti-peristaltic flow or reflux of gastric contents in the esophagus. On sensing the anti-peristaltic flow, the sensor module 101 provides this information to the microcontroller 102, which in turn activates the stimulator 103 to provide the required electrical stimulus that prevents the abnormal flow or reflux of gastric contents. In another embodiment, the sensor module 101 senses peristaltic flow of food from the esophagus into the stomach. On sensing the peristaltic flow, the sensor module 101 provides this information to the microcontroller 102, which in turn activates the stimulator 103 to provide the required electrical stimulus that prevents the flow of food from esophagus into stomach thus curtailing feeding. The sensor module 101, the microcontroller 102 and the stimulator 103 can communicate with each other using wired or wireless communication.

[0074] Referring to FIG. 2, an exemplary arrangement of electrodes of the sensor module is shown. The sensor module consists of three pairs of electrodes 201a, 201b, and 201c placed across the esophagus 202. In order to minimize the risk of rejection by the body, biocompatible electrodes such as gold, silver, platinum, titanium, or nitinol are used. Each pair of electrodes is placed at least 1 mm away from the nearest pair. As substances pass through the esophagus, it causes a change in impedance between the electrode pairs, and this forms the basis of detection of esophageal peristalsis or flow and its direction. The impedance across the esophagus is sensed by sending an ac voltage signal (2V p-p) and measuring the current, and the impedance is used to compute the speed of the esophageal flow. Depending on the electrode pair that senses the change in impedance first, the direction of flow can be determined. Thus if the electrode pair 201a detects a change in impedance first, followed by the pair 201b and then

by 201c, it implies that the flow is a normal swallow, that is, substances are passing down from the esophagus into the stomach. However, if the order of sensing in the electrodes is reversed, that is, electrode pair 201c is the first to detect a change in impedance in the esophagus, it implies that the flow is anti-peristaltic and indicates a reflux event from the stomach into the esophagus. It should be appreciated that other sensors, including electrical, pressure, photo, thermal and chemical, can be used in place of, or in combination with, the impedance sensors.

[0075] In a patient with GERD, when anti-peristaltic flow is sensed by the sensor electrodes, the stimulator is activated to provide the required stimulus to the muscles of the lower esophageal sphincter (LES). The LES acts as a barrier between the esophagus and the stomach; applying electrical stimulus to the LES muscles causes them to contract and prevent the abnormal flow or reflux of gastric contents into the esophagus.

[0076] In addition, applying principal component analysis algorithms to perform signal analysis and data processing and using pattern recognition techniques, the nature of the reflux (acidic or alkaline) and the chemical composition of the reflux can be analyzed in real time. This data can then be used to help in modulate the stimulus and establish stimulation patterns.

[0077] In a patient with obesity, when peristaltic flow is sensed by the sensor electrodes, the stimulator is activated to provide the required stimulus to the muscles of the esophagus or lower esophageal sphincter (LES). The LES acts as a barrier between the esophagus and the stomach; applying electrical stimulus to the LES muscles causes them to contract and prevent the flow of food from the esophagus into the stomach thus controlling the intake of food.

[0078] In addition, applying principal component analysis algorithms to perform signal analysis and data processing and using pattern recognition techniques, the nature of the bolus and the chemical composition of the bolus can be analyzed in real time. This data can then be used to modulate the stimulus and establish stimulation patterns.

[0079] FIG. 3 illustrates the major components and the working of the sensor module. The sensor module 300 comprises an oscillator 301, which in one embodiment, is a Wein bridge oscillator producing a sinusoidal waveform of 1 KHz, 2 Vpp. The sinusoidal waveform thus produced is then applied to the electrode system (sensors) 302 directly, which senses the change in current through the medium to determine the change in impedance, as mentioned previously. The sensed current is then converted into voltage using three current to voltage (I to V) converters 303, one for each electrode pair. Since the output of the I to V converters 303 is still sinusoidal, it needs to be converted into DC using AC to DC converters 304. The DC output is fed to the microcontroller (not shown in this figure) through a data acquisition (DAQ) card 305. The microcontroller checks whether the voltage is above or below the threshold and determines the impedance in accordance with the voltage signal. As shown in FIG. 3, signals from the sensor module are fed to the microcontroller using a USB link 306. Alternatively, the signals may be sent to the microcontroller in a wireless fashion using an RF link, a wireless link (Bluetooth or other protocol), an ultrasonic link, a thermal link, a magnetic, an electromagnetic or an optical link.

[0080] The detailed circuit diagram for the sensor module is shown in FIG. 4. Block 401 in FIG. 4 shows the circuit

details for the oscillator (301 of FIG. 3), while block 402 represents the circuit details for current to voltage converter (303 of FIG. 3) and block 403 represents AC to DC converter (304 of FIG. 3).

[0081] FIG. 5 illustrates a detailed circuit diagram for the microcontroller unit of the present invention. The microcontroller unit 500 consists of the microcontroller 501, a power management unit 502, and a level shifter unit 503. The microcontroller unit is designed to be portable, which can remotely (wirelessly) communicate with the sensor module and the stimulator. For this application, any suitable microcontroller 501 may be chosen. In one embodiment, a microcontroller from MSP430 family of Texas Instruments is used. Built around a 16-bit CPU, the MSP430 is designed for low cost, low power consumption embedded applications, and its architecture is particularly well suited for wireless RF or battery powered applications.

[0082] The power management unit 502 is used to convert output voltage from the power supply to the specified level of operating voltage of the microcontroller 501 (and its peripherals).

[0083] The microcontroller unit can be programmed using a computer such that it controls the stimulator to produce electrical pulses of varying shape, duration and frequency so as to produce the desired contractions in the LES or any other smooth muscle in the body. The interaction between microcontroller unit 500 and a computer for programming purposes is enabled by the level shifter unit 503 which converts UART data standard to RS232 level to enable communication through the serial port of the computer. Alternatively, communication may be carried out through the computer's USB link or in a wireless manner, using any suitable wireless standard. The microcontroller unit 500 is also provided with a JTAG port to facilitate programming and flash emulation. Additionally, the microcontroller unit is provided with six 8-bit General purpose I/O ports. Of these, two I/O pins are used for the indication of peristalsis and anti-peristalsis. The rest of the ports may be used for interfacing with other devices, such as a monitor.

[0084] Features of the microcontroller which help in achieving a simple yet effective design for the device of the present invention include:

[0085] Low Supply-Voltage Range—In one embodiment the range is between 1.8 V-3.6V.

[0086] Ultralow-Power Consumption, including a Standby Mode and Five Power-Saving Modes.

[0087] 16-Bit RISC Architecture, with 125-ns Instruction Cycle Time.

[0088] Supply Voltage Supervisor/Monitor with Programmable Level Detection.

[0089] The microcontroller is also provided with sufficient inbuilt memory (RAM as well as flash memory) for storing the programs required for the present application. The microcontroller can also store physiological data from the sensor which can be wirelessly interrogated and used to custom program the device to meet specific patient's need.

[0090] As used in the present invention, the stimulator is an electrophysiological stimulator capable of producing a pulse train to stimulate specific muscles resulting in the contraction of those muscles. This stimulation helps to correct any transient or permanent changes in the lower esophageal sphincter (LES) which might, for example, occur due to incompetence of the LES, transient LES relaxation, impaired expulsion of gastric reflux from the esophagus, or a hiatal hernia. Similarly

stimulation from the microstimulator can be used to modify or alter the contractility of any smooth muscle in the body to achieve any desired effect. For example, a stimulation from the microstimulator applied to the biliary system can cause the biliary system to contract thus altering the flow of biliary secretions into the intestinal tract.

[0091] With the transient or permanent changes in the muscle tone, the LES loses the tendency to contract which would otherwise prevent the reflux of the gastric contents into the esophagus. The current stimulator of the present invention stimulates the LES to contract and prevent the acid reflux into the esophagus, whenever the sensing module senses onset of anti-peristaltic flow of gastric contents. In one embodiment, the duration and/or frequency of the electrical pulses produced by are determined on the basis of the speed or directionality of esophageal flow detected by the sensing module. No stimulus is provided on sensing normal peristaltic flow.

[0092] In another application to treat obesity, the current stimulator of the present invention stimulates the LES to contract and prevent passage of food from the esophagus into the stomach producing the uncomfortable sensation of dysphagia, whenever the sensing module senses peristaltic flow associated with a swallow. The stimulator could be programmed to start stimulating the LES after a fixed duration after the onset of swallows based on patient's desired caloric intake. Alternatively, the stimulator can be triggered by the patient.

[0093] FIG. 6 illustrates an exemplary waveform of pulses generated by the stimulator of the present invention. Referring to FIG. 6, the exemplary waveform comprises two pulse trains—Pulse Train 1 601 and Pulse Train 2 602. The pulse trains comprise of positive as well as negative pulses. A negative pulse is automatically generated by the stimulator along with a positive pulse to remove the polarization of the electrodes. Thus in FIG. 6, Pulse Train 1 601 comprises two positive pulse 611p and 612p, and their corresponding negative pulses 611n and 612n. Pulse Train 1 601 is followed by Pulse Train 2 602, with the two pulse trains being essentially repetitions of the similar pulse groups. However in the FIG. 6, only the first positive pulse 621p and its corresponding negative pulse 621n are shown. The amplitude (in mA) of current for each of the positive pulses 611p, 612p and 621p in FIG. 6 is represented by A1 and the width or pulse duration in msec for each of the positive pulses is represented by W1. Similarly A2 represents the amplitude for each of the negative pulses 611n, 612n, and 621n, while W2 represents the pulse duration for each of the negative pulses. Depending upon the requirements, there can be delays denoted by D1 between each positive and negative pulse, and D2 between each negative and positive pulse. For the first positive and negative pulse 611p and 611n respectively, the amplitude and pulse width are equal. That is, for 611p and 611n, A1=A2, and W1=W2. However for the second positive pulse 612p and the corresponding negative pulse 612n in Pulse Train 1, the amplitudes A1 and A2 respectively are not equal, and their pulse widths W1 and W2, respectively, are also different. That is, pulses 612p and 612n are differently sized.

[0094] The positive and the negative pulse 621p and 621n respectively in case of Pulse Train 2 602, are identical to 611p and 611n of Pulse Train 1 601. Therefore, the amplitude and pulse width for pulses 611p and 611n are equal. That is, for 611p and 611n, A1=A2, and W1=W2.

[0095] The output of the stimulator, as controlled by the microcontroller, can be programmed to vary:

- [0096]** The number of pulses in a pulse train;
- [0097]** The shape of pulses in a pulse train;
- [0098]** The interval between pulse train repetitions;
- [0099]** The duration of each pulse;
- [0100]** The timing and amplitude of pulses in trains;
- [0101]** The desired amount of amperage to be provided to the LES;
- [0102]** The desired amount of potential to be provided to the LES, depending upon the load and the current produced.

[0103] Further, the electrical stimulus may have any shape necessary to produce the desired result, including a square, rectangular, sinusoidal, or saw tooth shape.

[0104] Optionally, the stimulus may be triggered by a transmitter (not shown) external to the human body, similar to a remote transmitter for a cardiac pacemaker.

[0105] FIG. 7 depicts the major components of the stimulator circuit by means of a block diagram. Referring to FIG. 7, output from the microcontroller is fed through a DAC (Digital to Analog Converter) 721 to the stimulator circuit. The DAC output 721, which is 0-2.5V, is then converted to a higher voltage level of $\pm 12V$ (bipolar) by the level shifter 701. A unity gain amplifier 708 and an amplifier 702 with gain of 5 aids in obtaining this high level shift. The level shifted voltage is then fed into an adder 703, which also receives the reference voltage input from the differential amplifier 705. The output of the adder 703 is again reinforced by means of a unity gain amplifier 704 so that the voltage drop at the resistance R_{REF} 709 does not affect the desired 12V, which is further given to the load 710. The load 710 is actually the resistance of the lower esophageal sphincter muscles, to which the voltage is applied to provide electrical stimulation.

[0106] The voltage across the resistance R_{REF} 709 is fed to the differential amplifier 705. The output of the differential amplifier 705 is again level shifted by the level shifter 706 in order to convert it into a positive value, which is supplied as input to an ADC (Analog to Digital Converter) 722. The other input to the level shifter 706 is provided by the inverting reference generator 707 which in turn is fed by the unity gain amplifier 708. The reference voltage received by the unity gain amplifier 708 is the reference output 723 from the microcontroller. The inverting reference generator 707 aids in obtaining a positive value for the ADC input 722. The output from the differential amplifier 705 is also fed to the adder 703, as mentioned earlier, and is used as a feed back to calculate the load resistance and to show the waveform across load.

[0107] The detailed circuit diagram for the stimulator is shown in FIG. 8, wherein 801 through 810 represent the circuit details for the corresponding components 701 through 710 of FIG. 7. Thus, referring to FIG. 8, output from the microcontroller is fed through a DAC 821 to the stimulator circuit. The DAC output 821 is then converted to a higher voltage level by the level shifter 801. A unity gain amplifier 808 and an amplifier 802 aid in obtaining this high level shift. The level shifted voltage is then fed into an adder 803, which also receives the reference voltage input from the differential amplifier 805. The output of the adder 803 is again fed to a unity gain amplifier 804 so that the voltage drop at the resistance R_{REF} 809 does not affect the desired 12V, which is further given to the load 810.

[0108] The voltage across the resistance R_{REF} 809 is reinforced by the differential amplifier 805. The output of the

differential amplifier 805 is again level shifted by the level shifter 706 in order to convert it into a positive value, which is supplied as input to an ADC 822. The other input to the level shifter 806 is provided by the inverting reference generator 807 which in turn is fed by the unity gain amplifier 808. The reference voltage received by the unity gain amplifier 808 is the reference output 823 from the microcontroller. The inverting reference generator 807 aids in obtaining a positive value for the ADC input 822. The output from the differential amplifier 805 is also fed to the adder, as mentioned earlier, and is used as a feed back to calculate the load resistance and to show the waveform across the load.

[0109] As mentioned previously, the microcontroller unit can be programmed using a computer such that it controls the stimulator to produce electrical pulses in accordance with the esophageal flow sensed by the sensor module. The programming can be done with the help of a suitable program running on the computer that sends simple commands to the microcontroller to set up pulse timing and amplitude. In one embodiment, the computer program code for programming the microcontroller is written using 'C' for Virtual Instrumentation (CVI). The CVI based program running on the computer also provides a graphical user interface (GUI) to make the programming task more convenient and user friendly. An exemplary screen shot of the GUI 900 is illustrated in FIG. 9. Various parameters pertaining to the pulse trains generated by the stimulator may be specified as well as observed using the GUI 900. Referring to FIG. 9, the relevant parameters corresponding to generated pulses include pulse amplitude (in mA) 901 for positive pulses and 902 for negative pulses, pulse duration or width (in mSec) 903 and 904—for positive and negative pulses respectively, delay between pulses (in mSec) 905 and 906—for positive and negative pulses respectively, the number of pulses in a train 907, the number of pulse trains 908, and inter-train delay 909. The GUI 900 also displays a schematic illustration 910 of the pulse train output produced by the stimulator, as well as the continuous waveform 911 for the same. Additionally, the GUI also allows the user to control the generation of pulse stimulus, by means of the 'stimulate' button 912. Thus, even though the timing of generation of pulse stimulus may be preprogrammed in the microcontroller, it can be over-ridden by user command whenever so required. Further, commands from the GUI 900 may be provided to the microcontroller using the serial interface of the computer, or by using any other wired or wireless interface.

[0110] In one embodiment, the device of the present invention is designed as a 'micro' device with all the major components—the stimulator, the sensor module, the microcontroller and the power source integrated into a single unit, for easy deployment at any desired location in the body. This microdevice is schematically illustrated in FIG. 10. Referring to FIG. 10, the microdevice 1011 contains an outer shell made of a biocompatible, hermetically sealed material such as glass, ceramic or metal or polymers. For this purpose, any material may be selected that keeps moisture out yet allows radiofrequency/electromagnetic or magnetic energy to pass through. The outer shell may also be constructed of an acid corrosion resistant material such as a suitable inert polymer. Examples of such materials include those from the Polyolefin family such as HDPE (high density polyethylene), LLDPE (linear low density polyethylene), and UHMWPE (ultra high molecular weight polyethylene); fluoropolymer materials like PTFETM (poly tetrafluoroethylene), FEPTM (fluorinated ethylene propylene) and others; polymethylpentene,

and polysulphons; some elastomers such as thermoplastic polyurethanes and C-Flex type block copolymers that are stable in acidic environments. Additionally the outer shell may be constructed of an acid corrosion resistant metal such as Platinum, Gold, Tantalum, Titanium, or suitable alloys thereof.

[0111] The microdevice may be coated with an antimicrobial agent such as an antibiotic or antifungal agent to prevent infection at the time of implantation. Additionally the microdevice may be coated with an immunosuppressant such as steroid, cyclosporine, tacrolimus, azathioprine, mycophenolate mofetil, muromonab CD-3 or antithymocyte globulin to prevent rejection.

[0112] The microdevice **1011** further comprises a microcontroller **1012** which stores the algorithm program for sensing and stimulation. In addition, the microcontroller **1012** is capable of receiving data and/or power from outside the body by inductive, radiofrequency (RF), electrical, magnetic, optical or other electromagnetic coupling. In one embodiment, microcontroller **1012** includes an inductive coil for receiving and transmitting RF data and/or power, an integrated circuit (IC) chip for decoding and storing stimulation parameters and generating stimulation pulses (either intermittent or continuous), and additional discrete electronic components such as one or more capacitors, resistors, coils, etc. The microcontroller **1012** also comprises a programmable memory for storing sets of data, and stimulation and control parameters. Programmable memory allows for stimulation and control parameters to be adjusted for each individual patient by means of inductive, radiofrequency (RF), or other electromagnetic coupling, to settings that are safe and efficacious and minimize the discomfort.

[0113] The microdevice **1011** may also comprise a sensor module **1013**, which senses various physiological parameters through the sensing electrode **1017**. The sensor module may be used for sensing any one or more of the various kinds of physiological stimuli, including, but not limited to esophageal peristalsis, esophageal pH, esophageal impedance, esophageal pressure, esophageal electrical activity, LES pressure, LES electrical activity, gastric peristalsis, gastric electrical activity, gastric chemical activity, gastric hormonal activity, gastric temperature, gastric pressure, gastric impedance and gastric pH, duodenal peristalsis, duodenal electrical activity, duodenal chemical activity, duodenal hormonal activity, duodenal temperature, duodenal pressure, duodenal impedance and duodenal pH, blood chemical and/or hormonal activity, vagal or other gastrointestinal neural activity and salivary chemical activity, biliary pressure, biliary electrical activity, biliary chemical activity, pancreatic pressure, pancreatic electrical activity, pancreatic chemical activity, pancreatic sphincter pressure, pancreatic sphincter electrical activity, biliary sphincter pressure, or biliary sphincter electrical activity, mesenteric vascular pressure, mesenteric vascular flow, and mesenteric vascular chemical contents.

[0114] The microdevice **1011** further comprises a power source **1014**. In one embodiment, the power source **1014** comprises an external power source coupled to microdevice **1011** via a suitable means, such as RF link. In another embodiment, the power source **1014** comprises a self-contained power source utilizing any suitable means of generation or storage of energy. Examples of such a power source include a primary battery, a replenishable or rechargeable battery such as a lithium ion battery, an electrolytic capacitor, and a super- or ultra- capacitor, etc. In case the self-contained

power source is replenishable or rechargeable, any suitable means of replenishing or recharging the power source may be used, such as an RF link, an optical link, a thermal link, or any other energy-coupling link.

[0115] The microdevice **1011** comprises a stimulator **1015** that is capable of generating a stimulus for stimulating the nerves or smooth muscle in any desired part in the body. The stimulus pulse generated by the stimulator **1015** may be square, rectangular, sinusoidal, or saw tooth. Further, the amperage and frequency of the generated stimulus may be adjusted to levels appropriate to achieve the desired stimulation effect. The desired stimulus pulse is delivered through the stimulation electrode **1018**. In one embodiment, the stimulating electrodes **1018** as well as the sensing electrode **1017** are made up of a conducting ceramic, conducting polymer, and/or a noble or refractory metal, such as gold, silver, platinum, iridium, tantalum, titanium, titanium nitride, niobium, stainless steel, or their alloys. The objective of this choice of materials is to minimize corrosion, electrolysis, and damage to the surrounding tissues. In one embodiment, the alloy constituting the sensing and stimulating **1017** electrodes **1018** is a shape memory alloy (SMA) that at body temperature conforms to a pre-designated shape to aid with anchoring or positioning for ideal sensing or stimulation. This makes the sensing and stimulating electrodes ideally conformed for sensing or stimulation at a specific portion of the body.

[0116] The microdevice **1011** also comprises an anchoring unit **1016** which helps anchor the microdevice to any given location in the body for short-term or long term implantation. For certain applications, a single electrode is used as the sensing electrode **1017** and the stimulating electrode **1018**. For other applications the sensing electrode **1017** and anchoring unit **1016** or the stimulating electrode **1018** and anchoring unit **1016** may be the same element. For still other applications the same element may be used as the sensing electrode **1017**, the anchoring unit **1016** and the stimulating electrode **1018**. The anchoring unit **1016** is provided with an attachment **1019**, which is designed such that it foreshortens after deployment into the body, thereby pulling the microdevice deeper into the particular site in body or snug with the wall and providing better retention. This novel design of the anchoring unit provides for easy and efficient implantation of the microdevice. In addition, pulling the microdevice snug to the wall provides a seal to the puncture site preventing leakage of intraluminal contents and resulting complications.

[0117] The present invention further provides a novel catheter design, which simplifies the deployment procedure, in addition to providing an effective deployment of the microdevice. FIG. 11 illustrates an exemplary catheter **1100**, used for the deployment of the microdevice **1111**. The catheter **1100** is designed to pass through the channel of an endoscope or laparoscope or alongside an endoscope over a guide-wire or over an attached track or an external channel. Optionally, single fiber endoscope or wireless optical or imaging devices can be incorporated into the catheter. It can also be radiologically or sterotactically driven to the site of deployment of the microdevice. Optionally, the catheter **1100** is provided with a needle **1121** to create a puncture into the site where the microdevice is to be implanted. In one embodiment, the anchoring unit **1116** can also be used to make the puncture. Further optionally, a suitable fluid such as saline, gonak (HPMC), air or CO₂ may be instilled through a port **1123** and the needle **1121** to create a temporary pocket in the wall of the organ where the microdevice is to be deployed. The catheter

1100 is also provided with a pusher **1122** which assists in deployment of the microdevice **1111** at the appropriate site. An optional lumen **1124** is provided for passage of a guidewire to further assist with accurate positioning and deployment of the microdevice **1111**.

[0118] FIG. 12 shows an exemplary deployment of the microdevice **1211** in the submucosa of the gastrointestinal tract using the novel catheter of the present invention. Typical layers of the gastrointestinal tract include the mucosa **1231**, submucosa **1232**, muscularis propria **1233**, serosa **1234** and the lumen **1235**. The anchoring unit **1216** is passed through the muscularis propria **1233** to anchor the microdevice **1211** to the wall. This is done because it is the natural tendency of the body to expel any foreign object in the submucosa **1232** into the lumen **1235** over time unless the object is anchored through the muscularis propria **1233** into the serosa **1234**. In the exemplary embodiment, the sensing electrodes **1217** are shaped such that after deployment they automatically position in either of the mucosa **1231**, submucosa **1232**, muscularis propria **1233**, and the lumen **1235** to sense physiological changes. The stimulating electrodes **1218** are shaped such that after deployment they automatically position in either submucosa **1232** to stimulate the submucosal nerves **1236** or in muscularis propria **1233** for direct smooth muscle stimulation or in serosa **1234** for stimulating serosal nerves **1237**, respectively.

[0119] To enable the requisite automated positioning, the various electrodes and/or anchoring unit are preferably made using shape memory technology. In one embodiment, electrodes and/or anchoring unit are physically structured to be positioned in a substantially straight line with the microstimulator, to thereby enable the electrode to pass through the catheter or channel of the endoscope, and, when deployed, the electrode and/or anchoring unit configures into a different shape, such as a hook, J-shape, U-shape, spring, a spiral disc, a spiral loop, a loop, a shape contoured to the implant site, corkscrew, T-shape, ship anchor or other non-linear shape. These various pre-deployment and post-deployment shapes are further described below. Such electrodes and/or anchoring unit preferably comprise a shape memory alloy (SMA), which is also known as a smart alloy, memory metal, or muscle wire and is equivalent to any alloy that conforms to a first pre-defined shape at one temperature (e.g. linear at room temperature) and a second pre-defined shape at a second, higher temperature (e.g. hook, J-shape, corkscrew, U-shape, spring, T-shape, a spiral disc, a spiral loop, a loop, a shape contoured to the implant site, ship anchor or other non-linear shape at internal body temperatures, i.e. 98.7 degrees Fahrenheit).

[0120] In certain embodiments, the anchoring unit **1216** may also function as the stimulating electrode **1218** to stimulate the serosal nerves **1237** or the outer longitudinal smooth muscle layer of muscularis propria **1233**. In another embodiment, the sensing unit **1217** may also function as the stimulating electrode **1218** to stimulate the submucosal nerves **1236** or the inner circular smooth muscle layer of muscularis propria **1233**. In one embodiment, the connecting unit **1219** of the anchoring unit **1216** is made up of shape memory alloy (SMA) that foreshortens, thereby pulling and embedding the microdevice **1211** into deep submucosa. This configuration is ideally suited for endoscopic deployment.

[0121] FIG. 13 shows another exemplary deployment of the microdevice **1311** in the biliary system using the catheter of the present invention. Typical parts of the biliary system

include gallbladder **1341**, cystic duct **1342**, common hepatic duct **1343**, common bile duct **1344**, biliary sphincter **1345** and the gall bladder lumen **1346**. The microdevice can be implanted using an endoscopic ultrasound, endoscopic retrograde cholangiography (ERC), laparoscopically, surgically or radiologically. During an ERC a guidewire is advanced into the gallbladder and the microdevice catheter is passed into the gallbladder over the guidewire. The anchoring unit **1316** is passed through a puncture in the wall of the gall bladder **1341**, thus anchoring the microdevice **1311** to the wall. In this situation the microdevice **1311** hangs freely in the gall bladder lumen **1346**.

[0122] In one embodiment, the sensing electrodes **1317** are shaped such that after deployment they automatically configure to be positioned in and sense in any one of the cystic duct **1342**, CBD **1344** and biliary sphincter **1345** to sense physiological changes in the biliary system. The stimulating electrodes **1317** are shaped such that after deployment they automatically configure to be positioned in and stimulate either one of the cystic duct **1342**, CBD **1344** or biliary sphincter **1345** to stimulate the biliary system. In certain embodiments, the anchoring unit **1316** may also function as the stimulating electrode **1318** to stimulate serosal nerves **1347** or gall bladder **1341**. In another embodiment, the sensing electrode **1317** may also function as the stimulating electrode **1318** to stimulate the biliary system. In the exemplary embodiment, the connecting unit **1319** of the anchoring unit **1316** is made up of SMA that foreshortens, thereby pulling and embedding the microdevice **1311** into the gall bladder wall. The mechanism also seals the puncture in the gall bladder wall, thereby preventing leakage of gall bladder contents into the peritoneal cavity and causing any complications.

[0123] It should be appreciated that the sensing function of an electrode and stimulating function of an electrode are happening at different times and, therefore, a single electrode can have both sensing and stimulating functionality. For example, EMG may be monitored in the LES and change in LES EMG may signal a transient relaxation event. Once the microstimulator senses that event it can pulse the LES through the same electrode to abolish the transient LES relaxation. The electrode after finishing the stimulation can then re-assume the sensing function. As long as one does not need to perform sensing and stimulation simultaneously, the same leads may serve both functions.

[0124] FIG. 14 shows another exemplary deployment of the microdevice **1411** in the serosa of the gastrointestinal tract using the using the catheter of the present invention. Typical layers of the gastrointestinal tract include the mucosa **1431**, submucosa **1432**, muscularis propria **1433**, serosa **1434** and the lumen **1435**. In an exemplary embodiment, the anchoring unit **1416** is passed through the muscularis propria **1433** to anchor the microdevice **1411** to the wall. In this embodiment the microdevice is on the serosal surface of the gastrointestinal tract. In one embodiment, the sensing electrode **1417** is shaped such that after deployment it automatically positions itself either one of the mucosa **1431**, submucosa **1432**, muscularis propria **1433**, serosa **1434** or the lumen **1435** to sense physiological changes. The stimulating electrode **1418** are shaped such that after deployment it automatically positions itself in either the submucosa **1432** to stimulate the submucosal nerves **1436**, or in the muscularis propria **1433** for direct smooth muscle stimulation or the serosa **1434** for stimulating the serosal nerves **1437**, respectively. In certain embodiments, the anchoring unit **1416** may also function as the

stimulating electrode **1418** to stimulate the submucosal nerves **1436** or the inner circular smooth muscle layer of muscularis propria **1433**. In another embodiment, the sensing unit **1417** may also function as the stimulating electrode **1418** to stimulate submucosal nerves **1436** or the inner circular smooth muscle layer of muscularis propria **1433**. The connecting unit **1419** of the anchoring unit **1416**, in one embodiment, is made up of SMA that foreshortens, thereby pulling and embedding the microdevice into the serosa. This configuration is ideally suited for laparoscopic or radiological placement.

[0125] FIGS. **15a** through **15h** illustrate various configurations of the anchoring unit. FIG. **15a** illustrates the pre-deployed position of the anchor **1516a**, wherein the anchor is positioned straight to facilitate puncture of the gastrointestinal wall. As mentioned previously, the anchor itself may be used to make the puncture or a separate needle may be used for the purpose. In this configuration, the connecting unit **1519a** which connects the anchoring unit **1516a** to the microdevice **1510a** is also positioned straight. FIG. **15b** illustrates an exemplary configuration of the anchor **1516b** after deployment. As can be seen from FIG. **15b**, after deployment the anchor **1516b** assumes the shape of a T-fastener, with the connecting unit **1519b** which connects to the microdevice **1510b** becoming spirally coiled. Alternatively, as illustrated in FIG. **15c**, the anchor **1516c** assumes the shape of a ship anchor after deployment. In this embodiment, the connecting unit **1519c** which connects the anchoring unit **1516c** to the microdevice **1510c** remains straight and may not foreshorten.

[0126] In an exemplary embodiment, the anchoring unit is made up of shape memory alloy (SMA), which provides flexibility of shape, as discussed above. Thus, in alternate configurations, post deployment the anchor may assume several different shapes, depending upon the site of deployment. Thus as shown in FIG. **15c**, the anchoring unit **1516c** assumes the shape of a spiral disc, while the connecting unit **1519c**, which connects to the microdevice **1510c**, becomes spirally coiled. In FIG. **15d** the anchoring unit **1516d** assumes the shape of a hook, with the connecting unit **1519d** which connects to the microdevice **1510d** becoming spirally coiled. In FIG. **15e** the anchoring unit **1516e** and the connecting unit **1519e** together assume the shape of a T bar, where the connecting unit **1519e** is coiled. In FIG. **15g**, the anchoring unit **1519g** connected to the microdevice **1510g** assumes a spiral loop shape, and in FIG. **15h** the anchoring unit **1519h** connected to the microdevice **1510h** assumes the shape of a loop. These various shapes per se result in shortening of the anchoring unit **1519** pulling the device deeper into or snug with the wall of the organ. It may be noted that more than one fasteners or anchors may be used, depending upon the requirement of the application. Further, the anchors may be used in more than one configuration depending on the organ or site of implantation. In addition the attachment (connecting unit) of the anchoring unit can also be made of SMA, as mentioned previously, and can foreshorten by coiling. The coiling is illustrated by **1519b**, **1519c** and **1519f** in FIGS. **15b**, **15c**, and **15f**, respectively, and it helps to pull the microdevice deeper into the wall of the organ.

[0127] FIGS. **16a** through **16h** show various configurations of the sensing electrode. FIG. **16a** illustrates the pre deployed position, where the sensing unit or electrode **1617a** is positioned straight to facilitate insertion and delivery of the microdevice **1610a** through a catheter into the lumen or wall of the organ. One of the possible post deployment states is

shown in FIG. **16b**. Referring to FIG. **16b**, the electrode **1617b** assumes a spiral shape after the microdevice **1610b** is deployed. The spiral shape is especially suitable when sensing at a tubular lumen site such as the cystic duct or common bile duct, as shown in FIG. **16c**. Referring to FIG. **16c**, the microdevice **1610c** is seen firmly anchored inside the gall bladder **1650c**, with the help of the anchoring device **1616c**, while the sensing electrode **1617c** is coiled in the bile duct **1652c**. In another embodiment shown in FIG. **16d**, the sensing electrode **1617d** assumes an acute angular configuration after the microdevice **1610d** is deployed. In FIG. **16f**, the sensing electrode **1617f** connected to the microdevice **1610f** assumes a hook configuration. The two configurations illustrated in FIGS. **16d** and **16f** are ideal for sensing intraluminal physiology at the gastroesophageal junction, which is depicted in FIG. **16e**.

[0128] Referring to FIG. **16e**, the microdevice **1610e** is deployed with the help of the anchoring device **1616e** inside the EG junction **1660e**, while the sensing electrode **1617e** assumes an angular configuration for optimum sensing. In the exemplary embodiment, the microdevice **1610e** is inserted into the submucosa per-orally via an endoscope and after deployment the SMA in the electrode assumes an angular or hook configuration bringing the electrode closer to the mucosa or the EG junction **1660e**. This provides for increased sensitivity of detection of physiological changes near the junction or esophageal sphincter. In another embodiment illustrated in FIG. **16g**, the microdevice **1610g** is of cylindrical shape, and one surface of the cylinder comprises a disc sensor or electrode **1617g**. This configuration is ideally suited for sensing at a large surface area in the mucosa, submucosa or muscularis. FIG. **16h** shows the microdevice **1610h** implanted in the submucosa **1662h** with the help of the anchoring unit **1616h**. The disc sensor **1617h** of the microdevice **1610h** in this configuration senses physiological changes from the inner circular muscle layer of the esophagus.

[0129] FIG. **17** shows various configurations of the stimulating electrode. In the pre deployed position illustrated in FIG. **17a**, the stimulating electrode **1718a** is straight, which facilitates insertion and delivery of the microdevice **1710a** through a catheter into the lumen or wall of the organ. One of the post deployment states is illustrated in FIG. **17b**, where the stimulating electrode **1718b** assumes a spiral shape. This shape is especially useful for stimulation in a tubular lumen such as the cystic duct, common bile duct, urethra or a blood vessel. FIG. **17c** illustrates the placement of the microdevice **1710c** and the stimulating electrode **1718c** in the bile duct **1750c**.

[0130] In another embodiment shown in FIG. **17d**, the stimulating electrode **1718d** assumes a hook configuration after the microdevice **1710d** is deployed. In FIG. **17f**, the stimulating electrode **1718f** assumes a double hook configuration after deployment of the microdevice **1710f**. It may be noted that the curvature of the hook may be designed accordingly to stimulate the deeper longitudinal smooth muscles or more superficial circular smooth muscle. For example, while a J-shaped hook configuration may be ideally suited to stimulate the deeper longitudinal smooth muscles, a U-shaped hook configuration is ideally suited to stimulate the more superficial circular smooth muscle. FIG. **17e** illustrates the microdevice **1710e** with a J-shaped stimulating electrode **1718e** deployed with the help of the anchoring unit **1716e** into a submucosal wall **1760e**.

[0131] In another embodiment shown in FIG. 17g, the microdevice 1710g is of cylindrical shape, and one surface of the cylinder comprises a disc stimulating electrode 1718g. This configuration is ideally suited for stimulating a large surface area. FIG. 17h shows the microdevice 1710h implanted with the help of the anchor 1716h in the submucosa 1770h, with the disc stimulator 1718h stimulating the inner circular muscle layer of the esophagus.

[0132] FIG. 18 shows various configurations of the anchoring system in a puncture needle. In the pre-deployed position illustrated in FIG. 18a, a ship anchor shaped anchoring system in its pre-deployment shape 1816a is housed in the needle 1821a with a slit to house the connecting unit 1819a. Referring to FIG. 18b, the needle 1821b, with connecting unit 1819b, is pushed through the wall of the organ 1810b carrying the anchor 1816b with it. On deployment as shown in FIG. 18b, the anchor comes out of its housing at the end of the needle 1821b and opens to its post-deployment position 1816b. The needle is then withdrawn and the open anchor 1816b anchors to the wall while the connecting unit 1819b comes out of the slit freeing the deployed anchor 1816b from the needle 1821b.

[0133] In another embodiment shown in FIG. 18c, a T-bar shaped anchoring system in its pre-deployment shape 1816c is housed in the needle 1821c with a slit to house the connecting unit 1819c. Referring to FIG. 18d, the needle 1821d is pushed through the wall of the organ 1810d carrying the anchor 1816d with it. On deployment as shown in FIG. 18d, the anchor 1816d comes out of its housing at the end of the needle 1821d and opens to its post-deployment position 1816d. The needle is then withdrawn and the deployed anchor 1816d anchors to the wall while the connecting unit 1819d comes out of the slit freeing the deployed anchor 1816d from the needle 1821d.

[0134] In a third embodiment shown in FIG. 18e, a hook anchoring system which is straight in its pre-deployment shape 1819e is housed in the needle 1821e with a slit. A small spherical knob 1880e holds the anchor and connecting unit 1819e in position in the needle 1821e preventing slippage of the anchor. Referring to FIG. 18f, the needle 1821f is pushed through the wall of the organ 1810f carrying the anchor 1819f with it. On deployment as shown in FIG. 18f, the knob comes out of its housing at the end of the needle 1821f and the anchor assumes its post-deployment hook position 1819f. The needle is then withdrawn and the deployed anchor 1819f anchors to the wall and comes out of the slit thus freeing the deployed anchor 1819f from the needle 1821f.

[0135] The aforementioned features of the present invention allow a physician for easy and expeditious deployment of the microdevice in the desired location. For example, if the microdevice is required to be deployed into the submucosa of the lower esophageal sphincter to treat various gastrointestinal disorders, then an exemplary procedure for deployment is illustrated in FIG. 19. Referring to FIG. 19a, in the first step of the procedure, the microdevice 1902a is positioned within a catheter 1901a, which is passed through the channel of an endoscope into the distal esophagus. In the predeployment position, the anchoring unit 1905a, the sensing electrode 1906a and the stimulating electrode 1907a are all in a straight line allowing for easy passage through the endoscope. In the next step, shown in FIG. 19b, a transmural puncture is made through the lower esophageal wall 1903b, thereby placing the catheter 1901b and microdevice 1902b in a position for

deployment. A submucosal pocket 1904b is optionally created using a saline injection for ease of deployment

[0136] Referring to FIG. 19c, the microdevice 1902c is pushed out of the catheter into the submucosal space while the anchoring unit 1905c is pushed transmurally into the serosal layer and the microdevice 1902c is deployed. The anchoring unit 1905c in the deployed position takes one of the post-deployment shapes, thereby anchoring the stimulators to the esophageal wall. After deployment, the attachment element of the anchoring unit 1905c, the sensing electrode 1906c and the stimulation electrode 1907c conform into their pre determined post-deployment position, thus pulling the microdevice 1902c deeper into the esophageal wall, and positioning the sensing electrode 1906c and stimulation electrode 1907c in their desired location. The puncture site generally heals in a few days, resulting in permanent implantation of the microdevice into the esophageal submucosa. Optionally, the puncture site may be closed with a clip, suture or sealed with a sealant or glue to expedite closure.

[0137] FIGS. 20a and 20b depict a procedure similar to the one depicted in FIGS. 19a through 19c, except performed in the gallbladder using an endoscope. A catheter containing the microdevice 2002a is used to deliver the microdevice 2002a to the implant site, puncture the gallbladder wall 2006a and deploy the anchor unit 2005a. Referring to FIG. 20b, the anchor unit 2005b conforms to a post deployment shape, thereby pulling the microdevice 2002b into the gallbladder 2006b wall and securing it thereto. After deployment the stimulation electrode 2007b conforms into its pre determined post-deployment spiral shape in the common bile duct.

[0138] It may be noted that apart from the method described above, the microdevice of the present invention along with the stimulating or sensing electrodes can also be placed by conventional surgical, laparoscopic, endoscopic radiological or other minimally invasive surgical techniques. Further, conventional electrode stimulation devices may be used in the practice of this invention.

[0139] Further, an evaluation of the physical effects induced by the proper operation of the present invention may be made by inspection with an X-ray, ultrasound, CAT scan or MRI or by insertion of a manometer catheter to measure pressures in the esophagus, stomach or the lower esophageal sphincter, a pH or impedance catheter to measure actual reflux events, etc.

[0140] While there has been illustrated and described what is at present considered to be a preferred embodiment of the present invention, it will be understood by those skilled in the art that various changes and modifications may be made, and equivalents may be substituted for elements thereof without departing from the true scope of the invention. In addition, many modifications may be made to adapt a particular situation or material to the teachings of the invention without departing from the central scope thereof. Therefore, it is intended that this invention not be limited to the particular embodiment disclosed as the best mode contemplated for carrying out the invention, but that the invention will include all embodiments falling within the scope of the appended claims.

1. (canceled)
2. (canceled)
3. (canceled)
4. (canceled)
5. (canceled)
6. (canceled)

7. (canceled)
 8. (canceled)
 9. (canceled)
 10. (canceled)
 11. (canceled)
 12. (canceled)
 13. (canceled)
 14. (canceled)
 15. (canceled)
 16. (canceled)
 17. (canceled)
 18. (canceled)
 19. (canceled)
 20. (canceled)
 21. (canceled)
 22. (canceled)
 23. (canceled)
 24. An electrode coupled to an anchoring unit comprising:
 an electrode; and
 an anchoring unit coupled to said electrode, wherein said anchoring unit comprises:
 a pre-deployment shape; and
 a post deployment shape, wherein said post deployment shape is different than the pre-deployment shape, wherein said anchoring unit is configured to attach said electrode to human tissue by puncturing said tissue at a puncture site, foreshortening upon deployment in the tissue to pull the electrode deeper into said tissue, and, upon being pulled deeper into said tissue, sealing said puncture site.
 25. The electrode of claim 24, wherein said anchoring unit is further used to facilitate puncture at an implant site for deployment of said electrode.

26. The electrode of claim 24, wherein, upon deployment of said anchoring unit, a shape of said anchoring unit changes to a predetermined shape

27. The electrode of claim 24, wherein said predetermined shape is determined based upon an implant site.

28. The electrode of claim 24, wherein the post-deployment shape of said anchoring unit is any one of a T-bar, a ship anchor, a spiral disc, a hook, a spiral loop, a loop or any non-linear shape capable of anchoring.

29. The electrode of claim 24, wherein the electrode is a stimulating electrode and is integrally formed with said anchoring unit.

30. The electrode of claim 29, wherein the post deployment shape of said anchoring unit is any one of a spiral shape, a hook, a double hook, a J-shape or a U-shape.

31. The electrode of claim 24, wherein the electrode is a sensing electrode and is integrally formed with said anchoring unit.

32. The electrode of claim 31, wherein the post deployment shape of said anchoring unit is any one of a spiral shape, an acute angular shape, a J-shape, a U-shape or a hook.

33. The electrode of claim 31, wherein said anchoring unit is also used to detect changes in physiological parameters.

34. The electrode of claim 29 where the anchoring unit and stimulating electrode are made of shape memory alloys.

35. The electrode of claim 31 where the anchoring unit and sensing electrode are made of shape memory alloys.

36. The electrode of claim 33, wherein said physiological parameters include at least one of pH, pressure, peristalsis, temperature, impedance, motion, flow, electrical activity, chemical activity, hormonal activity, and neural activity or muscular activity.

* * * * *

| | | | |
|----------------|--|---------|------------|
| 专利名称(译) | 用于生物系统电刺激的装置和植入系统 | | |
| 公开(公告)号 | US20140018657A1 | 公开(公告)日 | 2014-01-16 |
| 申请号 | US13/934040 | 申请日 | 2013-07-02 |
| [标]申请(专利权)人(译) | 恩多斯蒂姆股份有限公司 | | |
| 申请(专利权)人(译) | ENDOSTIM INC. | | |
| 当前申请(专利权)人(译) | ENDOSTIM INC. | | |
| [标]发明人 | SHARMA VIRENDER K | | |
| 发明人 | SHARMA, VIRENDER K. | | |
| IPC分类号 | A61B5/00 A61N1/05 | | |
| CPC分类号 | A61B5/6879 A61N1/0502 A61N1/05 A61N1/0551 A61N1/0558 A61N1/36007 | | |
| 优先权 | 61/023535 2008-01-25 US | | |
| 其他公开文献 | US8798753 | | |
| 外部链接 | Espacenet USPTO | | |

摘要(译)

描述了一种可植入刺激装置，其用于基于刺激的治疗，例如GERD或肥胖症。该装置设置有锚定单元，该锚定单元在展开时呈现针对部署位置优化的形状。设备中的感应电极和刺激电极也被设计成在展开时呈现合适的形状。还提供了一种新型导管，用于容易和迅速地部署该装置。

