



US010178961B2

(12) **United States Patent**  
**Tonar et al.**

(10) **Patent No.:** **US 10,178,961 B2**  
(45) **Date of Patent:** **Jan. 15, 2019**

(54) **APPARATUS AND METHODS FOR DETERMINING DAMAGED TISSUE USING SUB-EPIDERMAL MOISTURE MEASUREMENTS**

(71) Applicant: **Bruin Biometrics, LLC**, Los Angeles, CA (US)

(72) Inventors: **Ya-Chen Tonar**, San Pedro, CA (US); **Shannon Rhodes**, Venice, CA (US); **Marta Clendenin**, San Diego, CA (US); **Martin Burns**, Los Angeles, CA (US); **Kindah Jaradeh**, Sun Valley, CA (US)

(73) Assignee: **Bruin Biometrics, LLC**, Los Angeles, CA (US)

(\* ) Notice: Subject to any disclaimer, the term of this patent is extended or adjusted under 35 U.S.C. 154(b) by 0 days.

(21) Appl. No.: **15/273,202**

(22) Filed: **Sep. 22, 2016**

(65) **Prior Publication Data**

US 2017/0007153 A1 Jan. 12, 2017

**Related U.S. Application Data**

(63) Continuation of application No. 15/134,110, filed on Apr. 20, 2016.

(Continued)

(51) **Int. Cl.**

**A61B 5/053** (2006.01)  
**A61B 5/04** (2006.01)  
**A61B 5/00** (2006.01)

(52) **U.S. Cl.**

CPC ..... **A61B 5/0537** (2013.01); **A61B 5/0531** (2013.01); **A61B 5/445** (2013.01);  
(Continued)

(58) **Field of Classification Search**

CPC ..... **A61B 5/053**; **A61B 5/0531**; **A61B 5/0537**; **A61B 5/04085**; **A61B 5/0809**;  
(Continued)

(56) **References Cited**

**U.S. PATENT DOCUMENTS**

4,860,753 A 8/1989 Amerena  
5,284,150 A 2/1994 Butterfield et al.  
(Continued)

**FOREIGN PATENT DOCUMENTS**

EP 1372475 B1 1/2004  
EP 1 569 553 B1 9/2005  
(Continued)

**OTHER PUBLICATIONS**

Extended European Search Report dated Aug. 19, 2016, in European Patent Application No. 16169670.

(Continued)

*Primary Examiner* — Joseph Stoklosa

*Assistant Examiner* — Brian M Antiskay

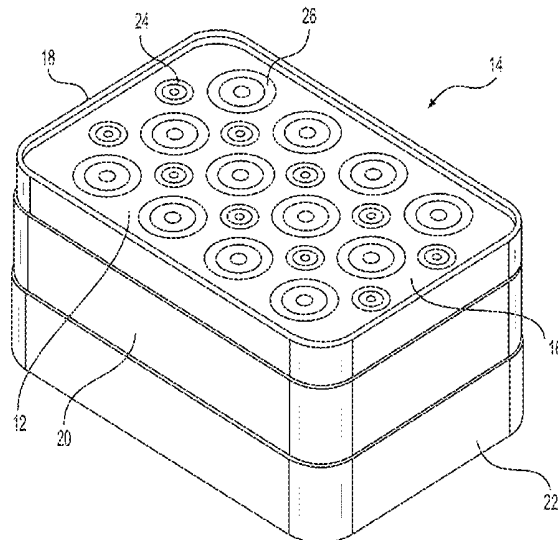
(74) *Attorney, Agent, or Firm* — David Marsh; Arnold & Porter Kaye Scholer LLP

(57) **ABSTRACT**

The present disclosure provides apparatuses and computer readable media for measuring sub-epidermal moisture in patients to determine damaged tissue for clinical intervention. The present disclosure also provides methods for determining damaged tissue.

**11 Claims, 16 Drawing Sheets**

16 →



## Related U.S. Application Data

(60) Provisional application No. 62/152,549, filed on Apr. 24, 2015.

## (52) U.S. Cl.

CPC ..... *A61B 5/447* (2013.01); *A61B 5/4875* (2013.01); *A61B 5/6801* (2013.01); *A61B 5/7278* (2013.01); *A61B 5/742* (2013.01); *A61B 5/746* (2013.01); *A61B 5/6843* (2013.01); *A61B 2560/0468* (2013.01); *A61B 2562/046* (2013.01)

## (58) Field of Classification Search

CPC ..... A61B 5/4878; A61B 5/4875; A61B 2562/0214; A61B 2562/14; A61N 1/0484; A61N 1/0424  
USPC ..... 600/372, 374, 388, 393, 442, 506, 547  
See application file for complete search history.

## (56) References Cited

## U.S. PATENT DOCUMENTS

6,330,479	B1	12/2001	Stauffer	
6,370,426	B1	4/2002	Campbell et al.	
6,577,700	B1	6/2003	Fan et al.	
6,963,772	B2*	11/2005	Bloom	A61B 5/01 600/547
7,079,899	B2	7/2006	Petrofsky	
7,315,767	B2	1/2008	Caduff et al.	
7,402,135	B2	7/2008	Leveque et al.	
7,783,344	B2	8/2010	Lackey et al.	
8,390,583	B2	3/2013	Forutanpour et al.	
8,925,392	B2	1/2015	Esposito et al.	
9,095,305	B2	8/2015	Engler et al.	
9,220,455	B2	12/2015	Sarrafzadeh et al.	
9,271,676	B2	3/2016	Alanen et al.	
9,398,879	B2	7/2016	Sarrafzadeh et al.	
9,763,596	B2	9/2017	Tonar et al.	
9,980,673	B2	5/2018	Sarrafzadeh et al.	
2001/0051783	A1	12/2001	Edwards et al.	
2002/0016535	A1	2/2002	Martin et al.	
2002/0070866	A1	6/2002	Newham	
2003/0036674	A1	2/2003	Bouton	
2003/0036713	A1	2/2003	Bouton et al.	
2003/0110662	A1	6/2003	Gilman et al.	
2003/0116447	A1	6/2003	Surridge et al.	
2004/0133092	A1	7/2004	Kain	
2004/0171962	A1	9/2004	Leveque et al.	
2004/0176754	A1	9/2004	Island et al.	
2004/0236200	A1	11/2004	Say et al.	
2004/0254457	A1	12/2004	Van Der Weide	
2005/0027175	A1	2/2005	Yang	
2005/0070778	A1	3/2005	Lackey et al.	
2005/0096513	A1	5/2005	Ozguz et al.	
2005/0177061	A1	8/2005	Alanen et al.	
2005/0203435	A1	9/2005	Nakada	
2005/0215918	A1*	9/2005	Frantz	A61B 5/0537 600/547
2005/0245795	A1	11/2005	Goode et al.	
2006/0058593	A1*	3/2006	Drinan	A61B 5/0531 600/301
2007/0191273	A1	8/2007	Ambati et al.	
2008/0009764	A1	1/2008	Davies	
2008/0259577	A1	10/2008	Hu et al.	
2008/0278336	A1	11/2008	Ortega et al.	
2009/0124924	A1*	5/2009	Error	A61B 5/053 600/547
2010/0113979	A1	5/2010	Sarrafzadeh et al.	
2010/0298687	A1	11/2010	Yoo et al.	
2011/0263950	A1	10/2011	Larson et al.	
2011/0301441	A1	12/2011	Bandic et al.	
2011/0313311	A1	12/2011	Gaw	
2012/0078088	A1	3/2012	Whitstone et al.	
2012/0150011	A1	6/2012	Besio	

2012/0190989	A1	7/2012	Kaiser et al.
2012/0271121	A1	10/2012	Della Tone et al.
2013/0041235	A1	2/2013	Rogers et al.
2013/0121544	A1	5/2013	Sarrafzadeh et al.
2013/0123587	A1	5/2013	Sarrafzadeh et al.
2013/0253285	A1	9/2013	Bly et al.
2013/0333094	A1	12/2013	Rogers et al.
2014/0121479	A1	5/2014	O'Connor et al.
2014/0288397	A1	6/2014	Sarrafzadeh et al.
2014/0200486	A1	7/2014	Bechtel et al.
2014/0275823	A1	9/2014	Lane et al.
2014/0316297	A1	10/2014	McCaughan et al.
2015/0002168	A1	1/2015	Kao et al.
2015/0094548	A1	4/2015	Sabatini et al.
2015/0366499	A1	12/2015	Sarrafzadeh et al.
2016/0101282	A1	4/2016	Bergelin et al.
2016/0174871	A1	6/2016	Sarrafzadeh et al.
2016/0220172	A1	8/2016	Sarrafzadeh et al.
2016/0270968	A1	9/2016	Stanford et al.
2016/0296268	A1	10/2016	Gee et al.
2016/0310034	A1	10/2016	Tonar et al.
2017/0014044	A1	1/2017	Tonar et al.
2017/0014045	A1	1/2017	Tonar et al.

## FOREIGN PATENT DOCUMENTS

JP	2003-169788	A	6/2003
JP	2005-52227		3/2005
JP	4418419		2/2010
WO	96/10951	A1	4/1996
WO	WO 02/080770	A1	10/2002
WO	WO 2004/105602	A1	12/2004
WO	WO 2006/029035	A1	3/2006
WO	2007/098762	A1	9/2007
WO	2011/022418	A2	8/2010
WO	WO 2011/143071	A2	11/2011
WO	WO 2015/195720	A1	12/2015
WO	2016/172263	A1	10/2016
WO	2017/214188	A1	12/2017

## OTHER PUBLICATIONS

Extended European Search Report dated Sep. 19, 2016, in European Patent Application No. 16166483.4.

International Search Report and Written Opinion dated Jul. 22, 2016, for International Patent Application No. PCT/US2016/28515.

International Search Report and Written Opinion dated Jul. 26, 2016, for International Patent Application No. PCT/US2016/28516.

Wang, "Biomedical System for Monitoring Pressure Ulcer Development," UCLA Electronic Theses and Dissertations, California, USA, pp. 1-123 (2013).

Jaskowski, "Evaluation of the Healing Process of Skin Wounds by Means of Skin Absolute Value of Electrical Impedance," *Dermatol. Mon.schr.*, 172(4):223-228 (1986).

Agency for Health Care Policy and Research, "Pressure Ulcers in Adults: Prediction and Prevention," *Clinical Practice Guideline—Quick Reference Guide for Clinicians*, 117 (1992).

Alanen, "Measurement of hydration in the stratum corneum with the MoistureMeter and comparison with the Corneometer," *Skin Research and Technology*, 10:32-37 (2004).

Alberts et al., "The Extracellular Matrix of Animals," *Molecular Biology of the Cell*, 1065-1127 (2002).

Allman et al., "Pressure Ulcer Risk Factors Among Hospitalized Patients With Activity Limitation," *JAMA*, 273:865-870 (1995).

Anonymous, "Recommended Practices for Positioning the Patient in the Perioperative Practice Setting," in *Perioperative Standards, Recommended Practices, and Guidelines*, AORN, Inc., 525-548 (2006).

Arao et al., "Morphological Characteristics of the Dermal Papillae in the Development of Pressure Sores," *World Wide Wounds*, (1999).

Australian Intellectual Property Office, Office Action dated May 1, 2014 for corresponding Australian patent application No. 2011253253 (pp. 1-10) and pending claims (pp. 11-15) pp. 1-15.

Australian Patent Office, Office Action dated Jun. 1, 2015, for corresponding Australian Patent Application No. 2011253253 (pp. 1-4) and claims (pp. 5-10) pp. 1-10.

(56)

## References Cited

## OTHER PUBLICATIONS

- Bader et al., "Effect of Externally Applied Skin Surface Forces on Tissue Vasculature," *Archives of Physical Medicine and Rehabilitation*, 67(11):807-11 (1986).
- Barnes, "Moisture Meters for Use on Thin Lumber and Veneers," *Moisture Register Co.*, 1-5 (1956).
- Bates-Jensen et al., "Subepidermal Moisture Predicts Erythema and Stage 1 Pressure Ulcers in Nursing Home Residents: A Pilot Study," *Journal of the American Geriatric Society*, 55:1199-1205 (2007).
- Bates-Jensen et al., "Subepidermal moisture differentiates erythema and stage 1 pressure ulcers in nursing home residents," *Wound Repair Regeneration*, 16:189-197 (2008).
- Bates-Jensen et al., "Subepidermal Moisture Is Associated With Early Pressure Ulcer Damage in Nursing Home Residents With Dark Skin Tones; Pilot Findings," *Journal of Wound Ostomy and Continence Nursing*, 36(3):277-284 (2009).
- Bergstrand et al., "Pressure-induced Vasodilation and Reactive Hyperemia at Different Depths in Sacral Tissue Under Clinically Relevant Conditions," *Microcirculation*, 21:761-771 (2014).
- Brem et al. "High cost of stage IV pressure ulcers," *American Journal of Surgery*, 200:473-477 (2010).
- Brienza et al., "Friction-Induced Skin Injuries—Are They Pressure Ulcers?," *Journal of Wound Ostomy and Continence Nursing*, 42(1):62-64 (2015).
- Carmo-Araujo et al., "Ischaemia and reperfusion effects on skeletal muscle tissue: morphological and histochemical studies," *International Journal of Experimental Pathology*, 88:147-154 (2007).
- Ceelen et al., "Compression-induced damage and internal tissue strains are related," *Journal of Biomechanics*, 41:3399-3404 (2008).
- Ching et al., "Tissue electrical properties monitoring for the prevention of pressure sore," *Prosthetics and Orthotics International*, 35(4):386-394 (2011).
- Cledenin et al., "Inter-operator and inter-device agreement and reliability of the SEM Scanner," *Journal of Tissue Viability*, 24(1):17-23 (2015).
- De Lorenzo et al., "Predicting body cell mass with bioimpedance by using theoretical methods: a technological review," *Journal of Applied Physiology*, 82(5):1542-1558 (1997).
- Demarre et al., "The cost of pressure ulcer prevention and treatment in hospitals and nursing homes in Flanders: A cost-of-illness study," *International Journal of Nursing Studies*, 1-14 (2015).
- Doddre et al., "Bioimpedance of soft tissue under compression," *Physiology Measurement*, 33(6):1095-1109 (2012).
- DuPont, "General Specifications for Kapton Polyimide Film," Retrieved from Dupont: [http://www2.dupont.com/Kapton/en\\_US/assets/downloads/pdf/Gen\\_Specs.pdf](http://www2.dupont.com/Kapton/en_US/assets/downloads/pdf/Gen_Specs.pdf), pp. 1-7 (2012).
- Dupont, "Pyralux FR Coverlay, Bondply & Sheet Adhesive," webpage, Retrieved from: [www2.dupont.com/Pyralux/en\\_US/products/adhesives\\_films/FR/FR\\_films.html](http://www2.dupont.com/Pyralux/en_US/products/adhesives_films/FR/FR_films.html) pp. 1-2 (2012).
- DuPont, "Pyralux® FR Copper-clad Laminate," webpage, Retrieved from: [www2.dupont.com/Pyralux/en\\_US/products/laminate/FR/pyralux\\_fr.html](http://www2.dupont.com/Pyralux/en_US/products/laminate/FR/pyralux_fr.html), pp. 1-2 (2012).
- Eberlein-Gonska et al., "The Incidence and Determinants of Decubitus Ulcers in Hospital Care: An Analysis of Routine Quality Management Data at a University Hospital," *Deutsches Arzteblatt International*, 110(33-34):550-556 (2013).
- European Patent Office, ESSR dated Aug. 22, 2014 for corresponding European Patent Application No. 117811061.4 (pp. 1-7) and pending claims (pp. 3-10) pp. 1-10.
- European Patent Office, Office Action dated Jul. 13, 2015, for corresponding European Patent Application No. 11781061.4 (pp. 1-5) and claims (pp. 6-9) pp. 1-9.
- Gabriel, "Compilation of the Dielectric Properties of Body Tissues at Rf and Microwave Frequencies Report," *Occupational and Environmental Health Directorate*, (1996).
- Gabriel et al., "The dielectric properties of biological tissues: II. Measurements in the frequency range 10 Hz to 20 GHz," *Physics in Medicine and Biology*, 41:2251-69 (1996).
- Gardiner et al., "Incidence of hospital-acquired pressure ulcers—a population-based cohort study," *International Wound Journal*, 11(6):696-700 (2014).
- Gershon et al., "SEM Scanner Readings to Assess Pressure Induced Tissue Damage," Proceedings of the 17th Annual European Pressure Ulcer Advisory Panel (EPUAP) meeting, Stockholm, Sweden (2014).
- Gonzalez-Correa et al., "Electrical bioimpedance readings increase with higher pressure applied to the measuring probe," *Physiology Measurement*, 26:S39-S47 (2005).
- Guihan et al., "Assessing the feasibility of subepidermal moisture to predict erythema and stage 1 pressure ulcers in persons with spinal cord injury: A pilot study," *Journal of Spinal Cord Medicine*, 35(1):46-52 (2012).
- Harrow, "Subepidermal moisture surrounding pressure ulcers in persons with a spinal cord injury: A pilot study," *Journal of Spinal Cord Medicine*, 37(6):719-728 (2014).
- Houwing et al., "Pressure-induced skin lesions in pigs: reperfusion injury and the effects of vitamin E," *Journal of Wound Care*, 9(1):36-40 (2009).
- Huang et al., "A device for skin moisture and environment humidity detection," *Sensors and Actuators B: Chemical*, 206-212 (2008).
- International Search Report and Written Opinion dated Feb. 9, 2012 for International Patent Application No. PCT/US2011/035618.
- International Search Report and Written Opinion dated Apr. 20, 2016 for International Patent Application No. PCT/US2016/28515.
- Jan et al., "Local cooling reduces skin ischemia under surface pressure in rats: an assessment by wavelet analysis of laser Doppler blood flow oscillations," *Physiology Measurement*, 33(10):1733-1745 (2012).
- Jiang et al., "Expression of cytokines, growth factors and apoptosis-related signal molecules in chronic pressure ulcer wounds healing," *Spinal Cord*, 52(2):145-151 (2014).
- Jiang et al., "Ischemia-Reperfusion Injury-Induced Histological Changes Affecting Early Stage Pressure Ulcer Development in a Rat model," *Ostomy Wound Management*, 57:55-60 (2011).
- Jiricka et al., "Pressure Ulcer Risk factors in an ICU Population," *American Journal of Critical Care*, 4:361-367 (1995).
- Kanai et al., "Electrical measurement of fluid distribution in legs and arms," *Medical Progress through Technology Journal*, 12:159-170 (1987).
- Kasyua et al., "Potential application of in vivo imaging of impaired lymphatic duct to evaluate the severity of pressure ulcer in mouse model," *Scientific Reports*, 4:4173 (2014).
- Lee, "CapSense Best Practices," *Application Note 2394*, 1-10 (2007).
- Loerakker et al., "The effects of deformation, ischemia, and reperfusion on the development of muscle damage during prolonged loading," *Journal of Applied Physiology*, 111(4):1168-1177 (2011).
- Loerakker et al., "Temporal Effects of Mechanical Loading on Deformation-Induced Damage in Skeletal Muscle Tissue," *Annual Review of Biomedical Engineering*, 38(8):2577-2587 (2010).
- Lyder et al., "Quality of Care for Hospitalized Medicare Patients at Risk for Pressure Ulcers," *Archives of Internal Medicine*, 161:1549-1554 (2001).
- Martinsen, "Bioimpedance and Bioelectricity Basics," *Elsevier Academic Press*, Chapters 1 and 10 (2011).
- Mathiesen et al., "Are labour-intensive efforts to prevent pressure ulcers cost-effective?" *Journal of Medical Economics*, 16(10):1238-1245 (2013).
- Matthie et al., "Analytic assessment of the various bioimpedance methods used to estimate body water," *Journal of Applied Physiology*, 84(5):1801-1816 (1998).
- Miller et al., "Lymphatic Clearance during Compressive Loading," *Lymphology*, 14(4):161-166 (1981).
- Moore et al., "A randomised controlled clinical trial of repositioning, using the 30° tilt, for the prevention of pressure ulcers," *Journal of Clinical Nursing*, 20:2633-2644 (2011).
- Moore et al., "Pressure ulcer prevalence and prevention practices in care of the older person in the Republic of Ireland," *Journal of Clinical Nursing*, 21:362-371 (2012).

(56)

## References Cited

## OTHER PUBLICATIONS

Moore et al., "A review of PU prevalence and incidence across Scandinavia, Iceland and Ireland (Part I)", *Journal of Wound Care*, 22(7):361-362, 364-368 (2013).

Mulasi, "Bioimpedance at the Bedside: Current Applications, Limitations, and Opportunities," *Nutritional Clinical Practice*, 30(2):180-193 (2015).

National Pressure Ulcer Advisory Panel et al., "Prevention and Treatment of Pressure Ulcers: Clinical Practice Guideline," *Cambridge Media*, (2014).

Nixon et al., "Pathology, diagnosis, and classification of pressure ulcers: comparing clinical and imaging techniques," *Wound Repair and Regeneration*, 13(4):365-372 (2005).

Nuutinen et al., "Validation of a new dielectric device to assess changes of tissue water in skin and subcutaneous fat," *Physiological Measurement*, 25:447-454 (2004).

O'Goshi, "Skin conductance; validation of Skicon-200EX compared to the original model, Skicon-100," *Skin Research and Technology*, 13:13-18 (2007).

Oomens et al., "Pressure Induced Deep Tissue Injury Explained," *Annual Review of Biomedical Engineering*, 43(2):297-305 (2015).

Scallan et al., "Chapter 4: Pathophysiology of Edema Formation," *Capillary Fluid Exchange: Regulation, Functions, and Pathology*, 47-61 (2010).

Schultz et al., "Extracellular matrix: review of its role in acute and chronic wounds," *World Wide Wounds*, 1-20 (2005).

Schwan, "Electrical properties of tissues and cells," *Advances in Biology and Medical Physics*, 15:148-199 (1957).

Sener et al., "Pressure ulcer-induced oxidative organ injury is ameliorated by beta-glucan treatment in rats," *International Immunopharmacology*, 6(5):724-732 (2006).

Sewchuck et al., "Prevention and Early Detection of Pressure Ulcers in Patients Undergoing Cardiac Surgery," *AORN Journal*, 84(1):75-96 (2006).

Sprigle et al., "Analysis of Localized Erythema Using Clinical Indicators and Spectroscopy," *Ostomy Wound Management*, 49:42-52 (2003).

Stekelenburg et al., "Deep Tissue Injury: How Deep is Our Understanding?" *Archives of Physical Medicine Rehabilitation*, 89(7):1410-1413 (2008).

Stekelenburg et al., "Role of ischemia and deformation in the onset of compression-induced deep tissue injury: MRI-based studies in a rat model," *Journal of Applied Physiology*, 102:2002-2011 (2007).

Swisher et al., "Impedance sensing device enables early detection of pressure ulcers in vivo," *Nature Communications*, 6:6575-6584 (2015).

Thomas et al., "Hospital-Acquired Pressure Ulcers and Risk of Death," *Journal of the American Geriatrics Society*, 44:1435-1440 (1996).

Valentinuzzi et al., "Bioelectrical Impedance Techniques in Medicine. Part II: Monitoring of Physiological Events by Impedance," *Critical Reviews in Biomedical Engineering*, 24(4-6):353-466 (1996).

Vangilder et al., "Results of Nine International Pressure Ulcer Prevalence Surveys: 1989 to 2005," *Ostomy Wound Management*, 54(2):40-54 (2008).

Wagner et al., "Bioelectrical Impedance as a Discriminator of Pressure Ulcer Risk," *Advances in Wound Care*, 9(2):30-37 (1996).

Watanabe et al., "CT analysis of the use of the electrical impedance technique to estimate local oedema in the extremities in patients with lymphatic obstruction," *Medical and Biological Engineering and Computing*, 36(1):60-65 (1998).

Weiss, "Tissue destruction by neutrophils," *The New England Journal of Medicine*, 320(6):365-76 (1989).

Extended European Search Report dated Mar. 13, 2017, in European Patent Application No. 16196899.5.

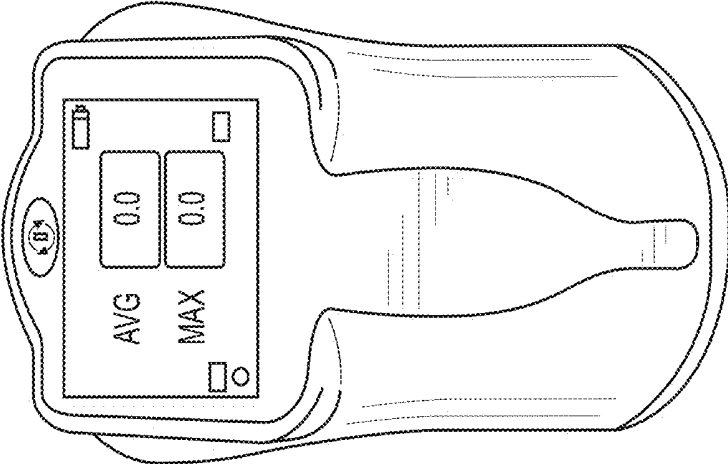
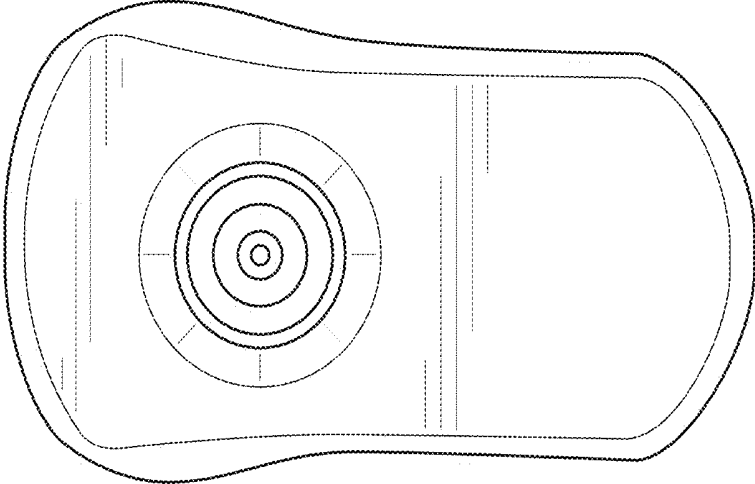
International Search Report dated Jul. 12, 2018, issued in International Patent Application No. PCT/US2018/016736.

International Search Report dated Apr. 12, 2018, issued in International Patent Application No. PCT/US2018/016731.

International Search Report dated Apr. 12, 2018, issued in International Patent Application No. PCT/US2018/016738.

International Search Report dated Apr. 26, 2018, issued in International Patent Application No. PCT/US2018/016741.

\* cited by examiner



**FIG. 1**

10

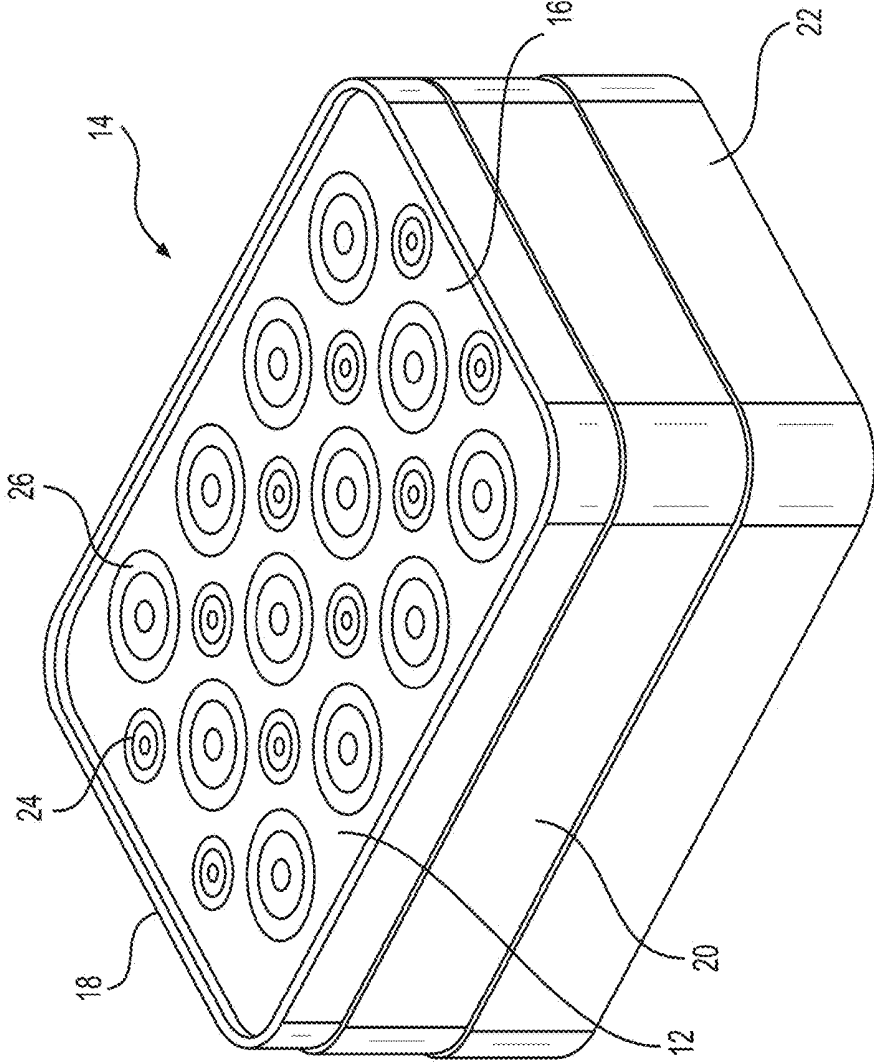
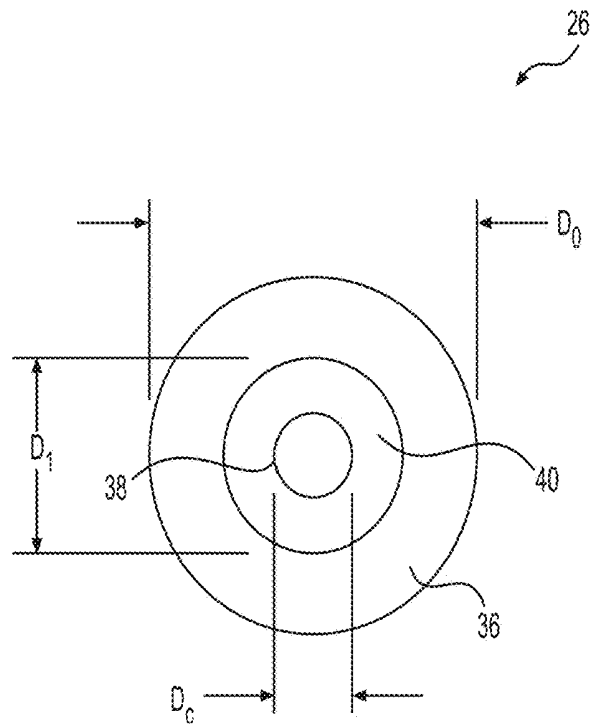
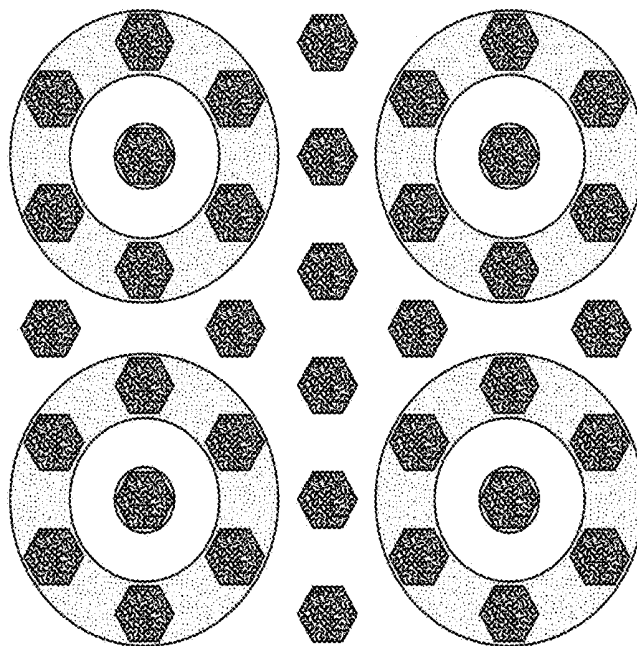


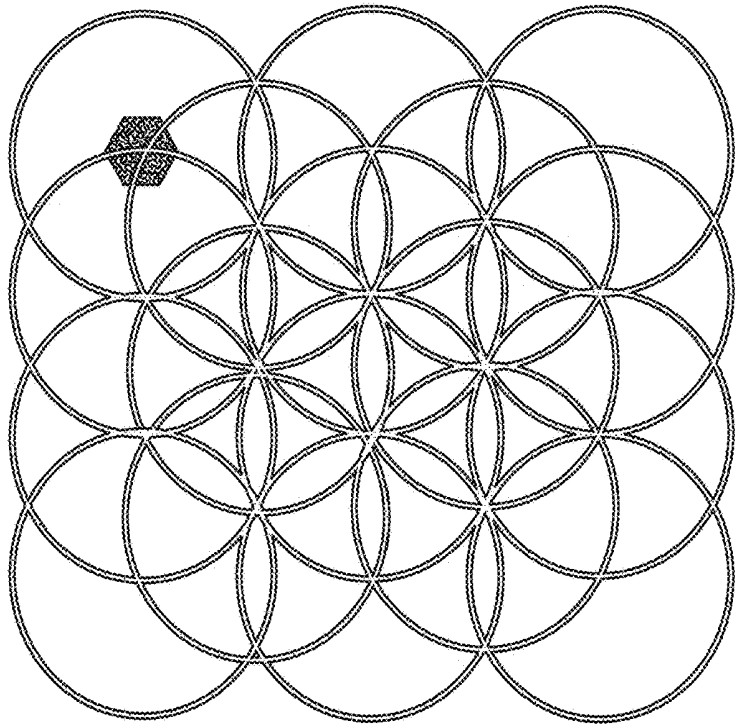
FIG. 2



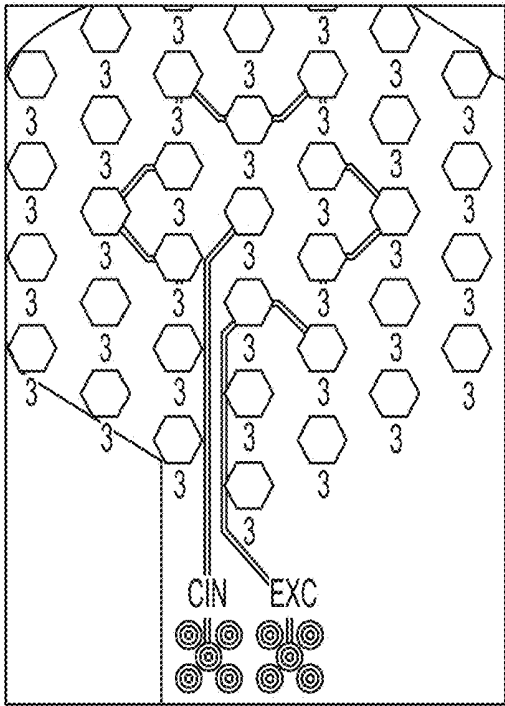
**FIG. 3A**



**FIG. 3B**



**FIG. 3C**



**FIG. 3D**

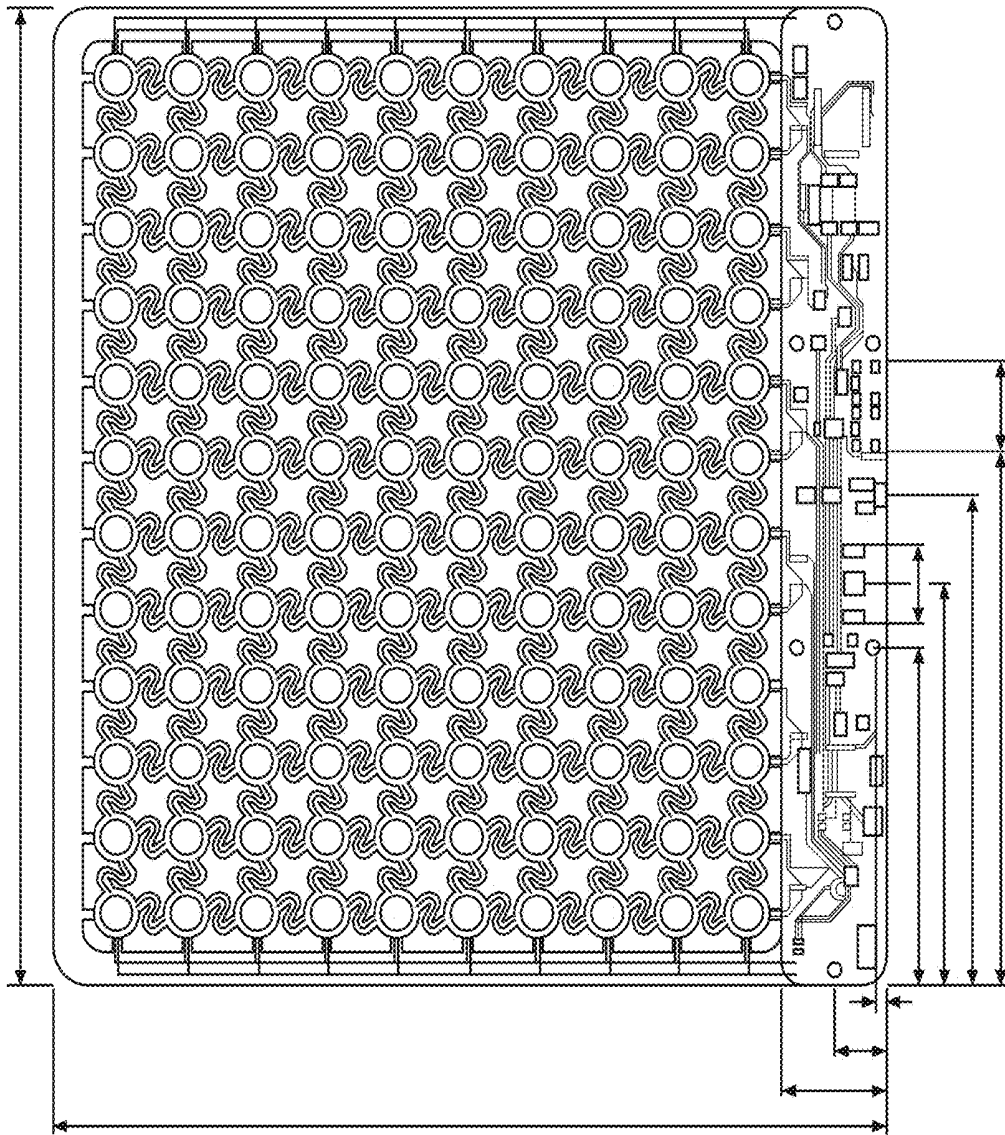
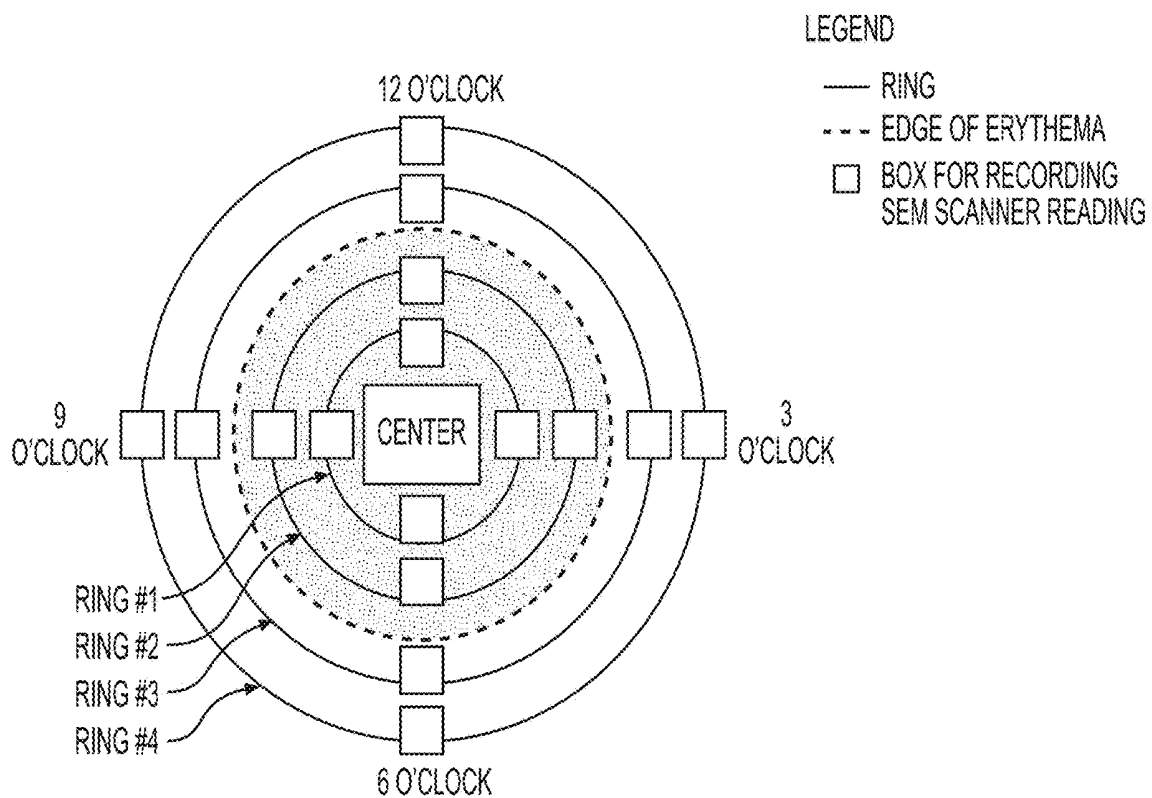
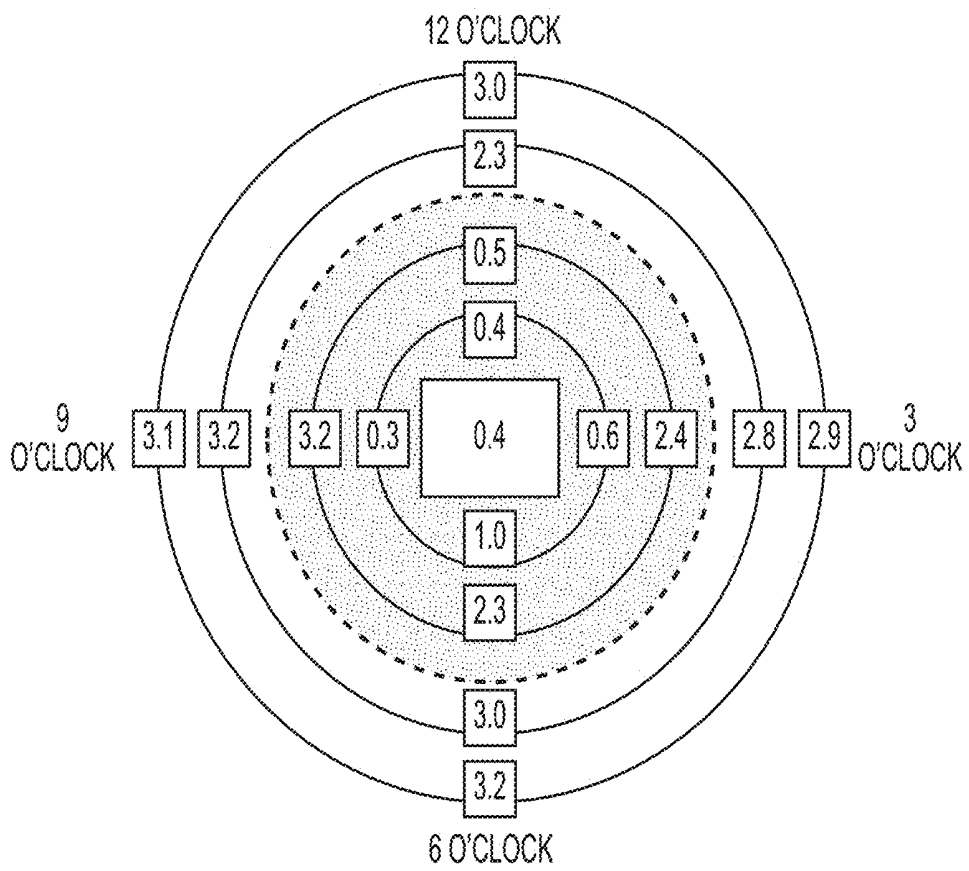


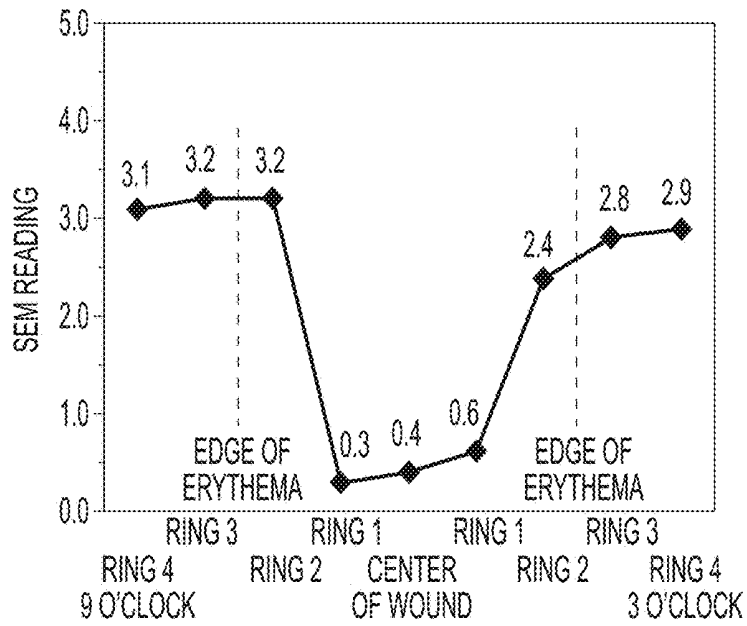
FIG. 3E



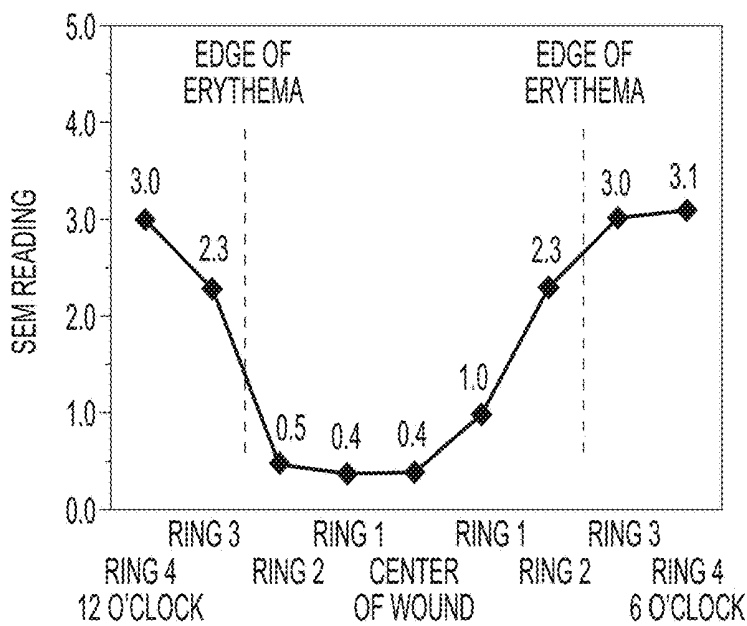
**FIG. 4**



**FIG. 5A**

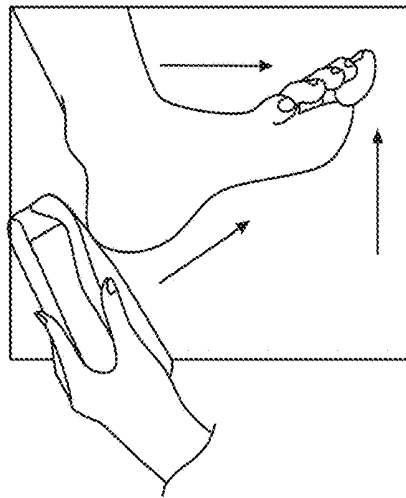


**FIG. 5B**

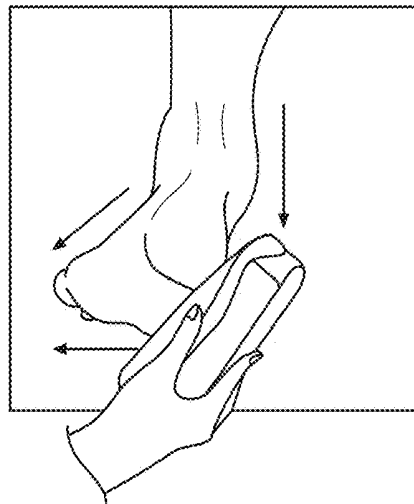


**FIG. 5C**

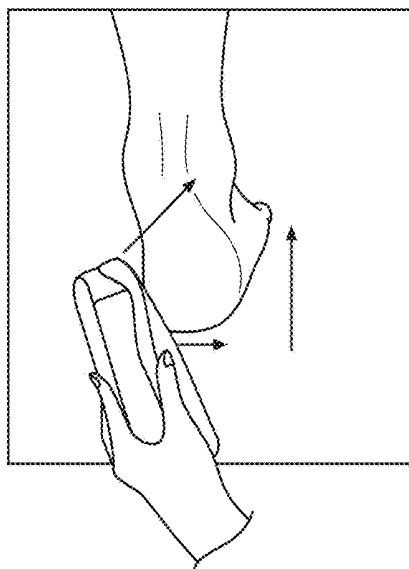
**FIG. 6A**



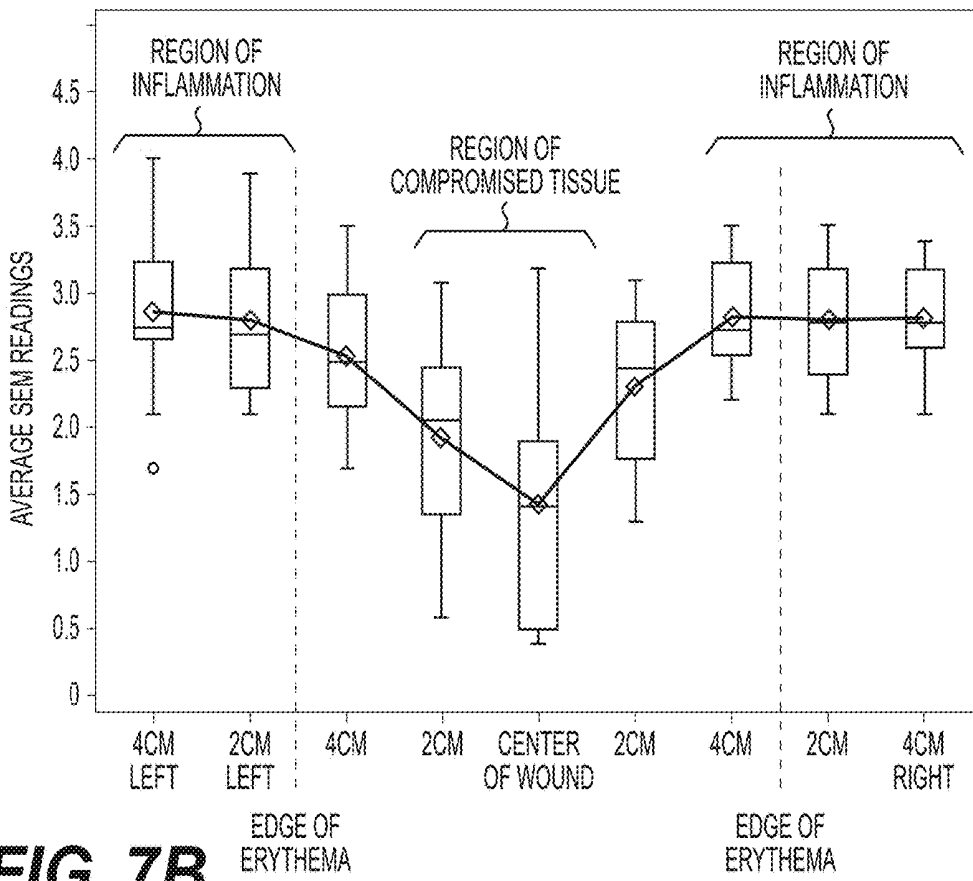
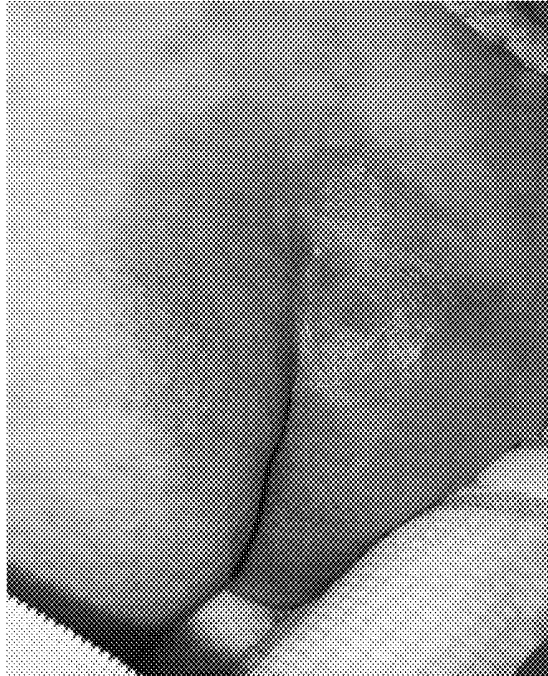
**FIG. 6B**

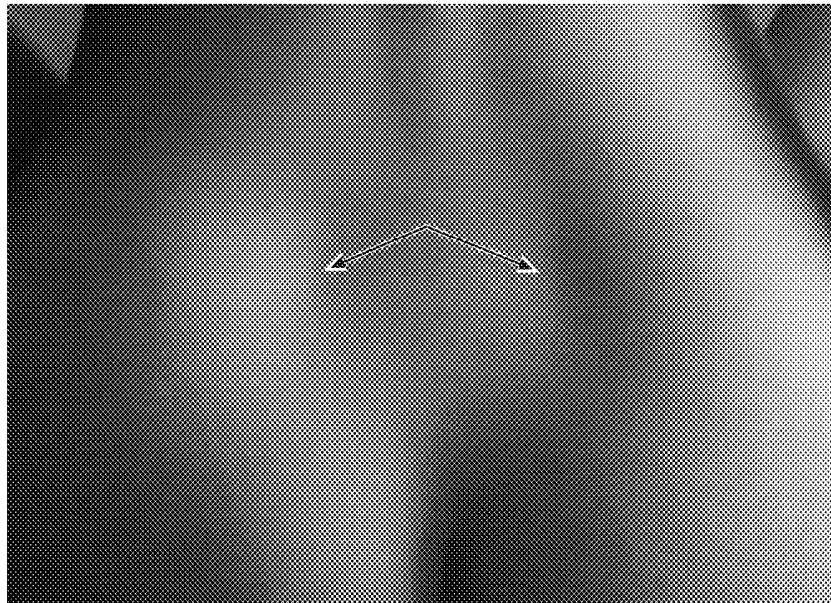


**FIG. 6C**

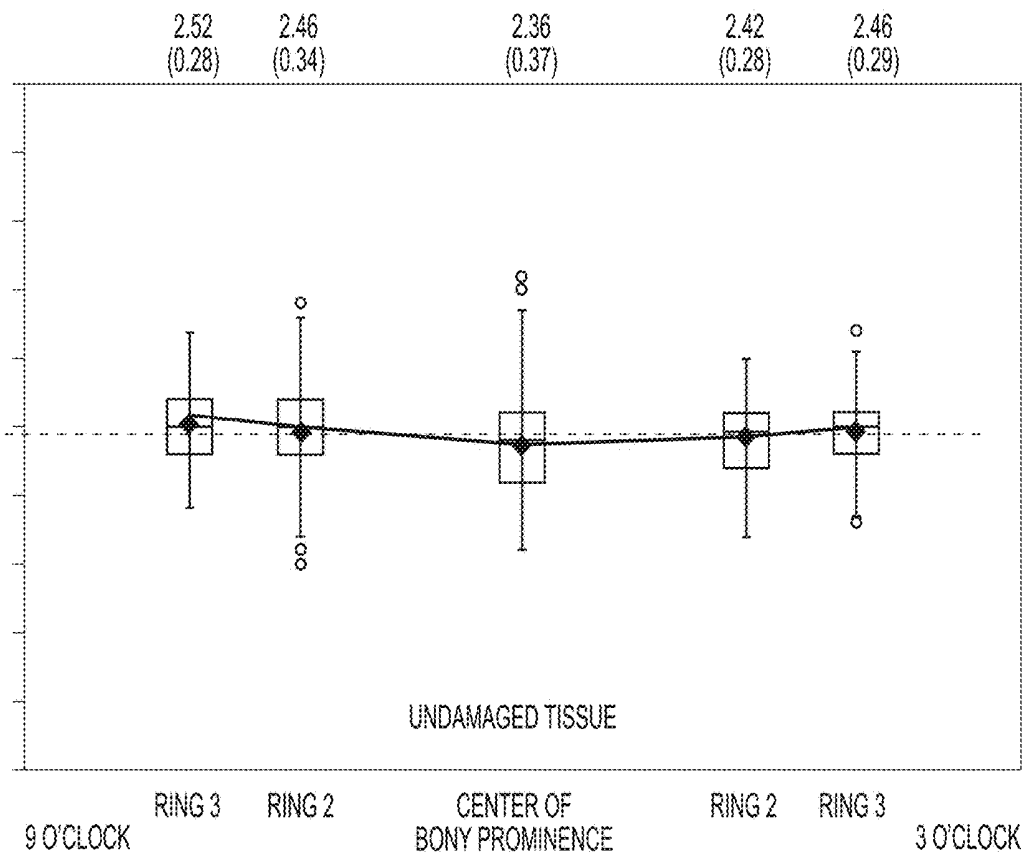


**FIG. 7A**





**FIG. 8A**



**FIG. 8B**



FIG. 9B

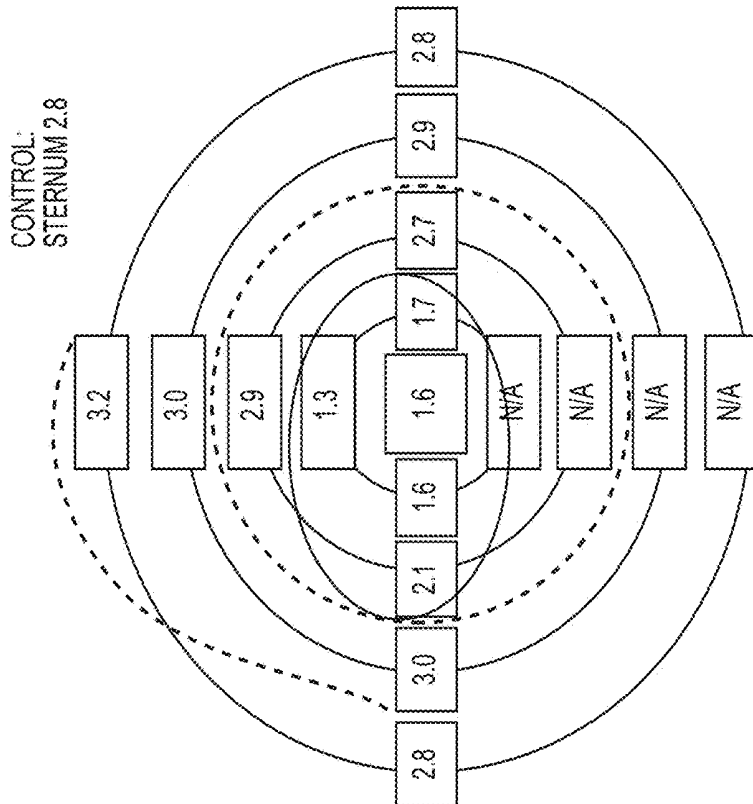
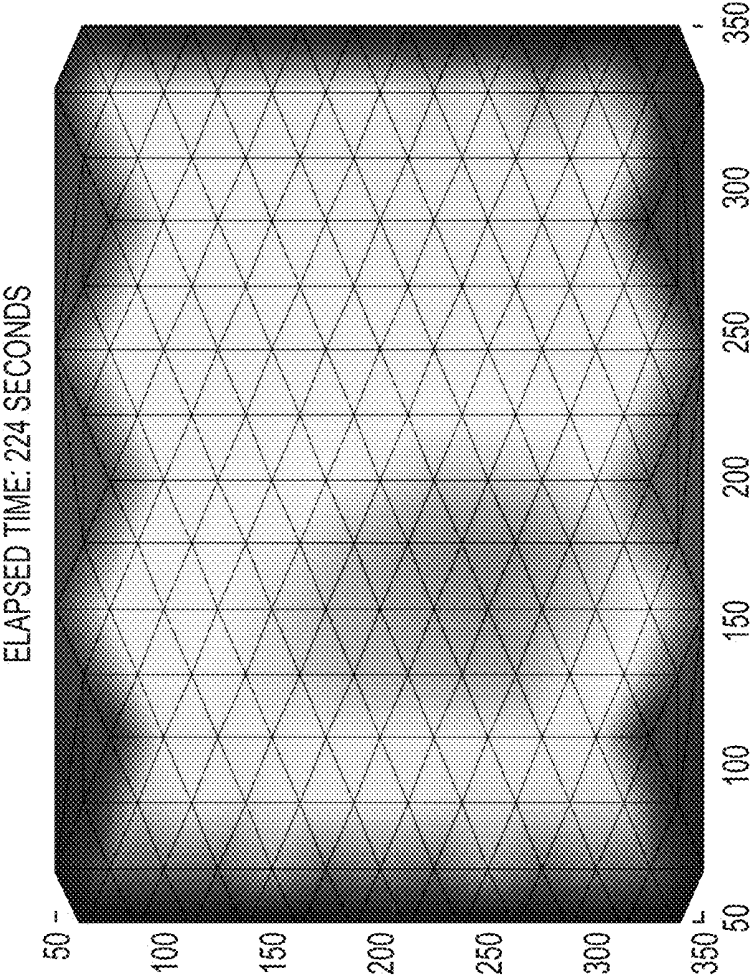
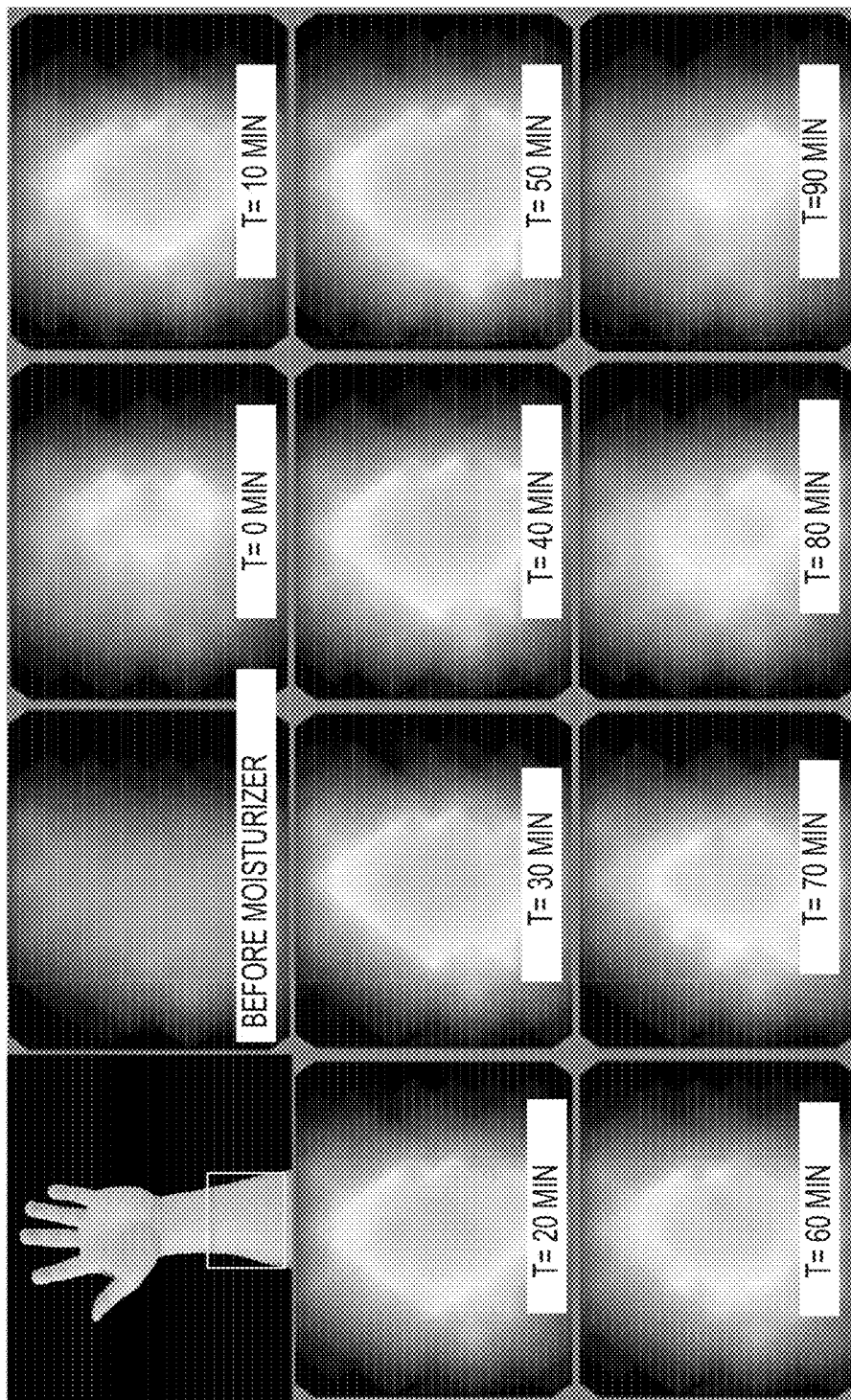


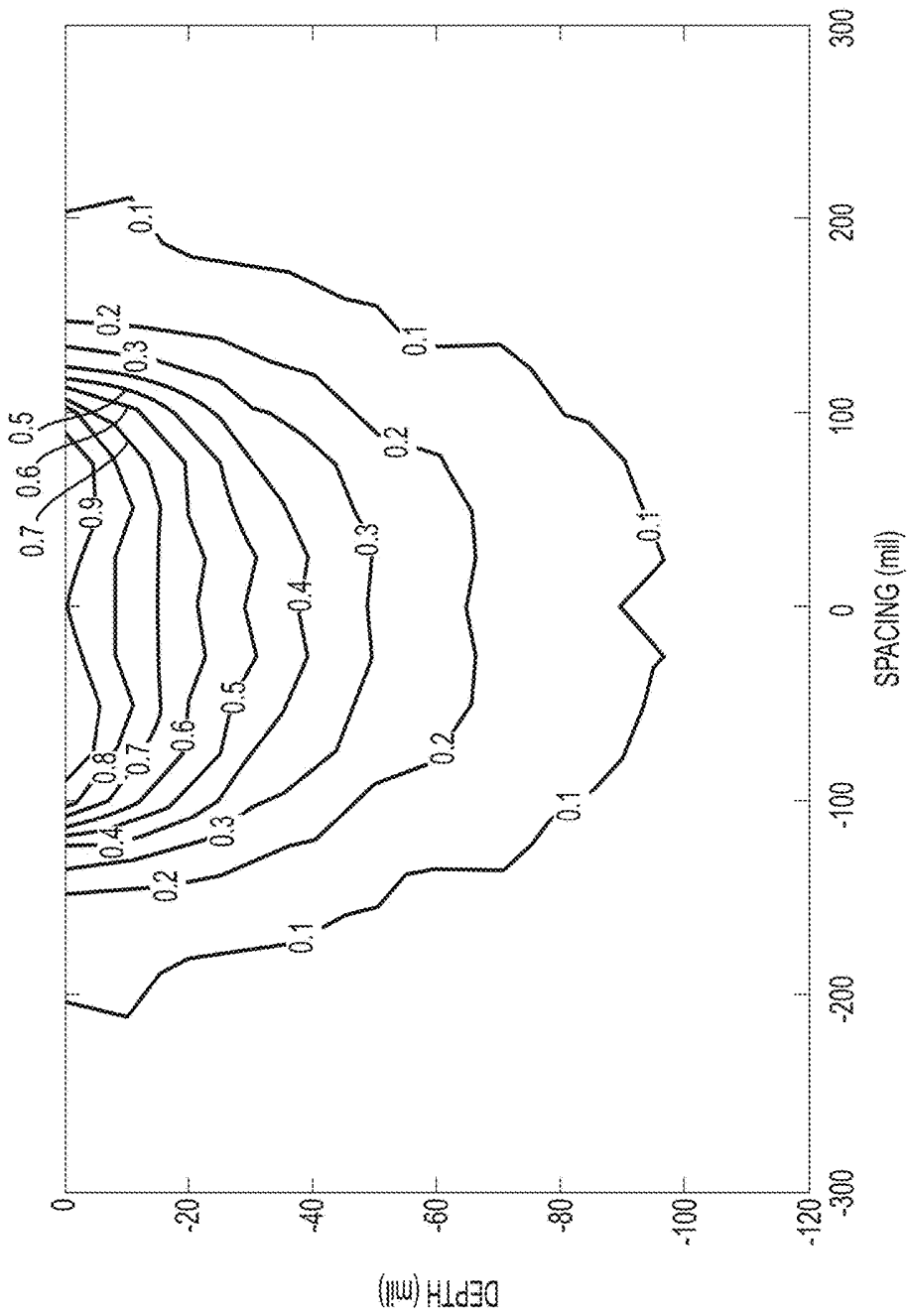
FIG. 9A



**FIG. 10**



**FIG. 11**



**FIG. 12A**

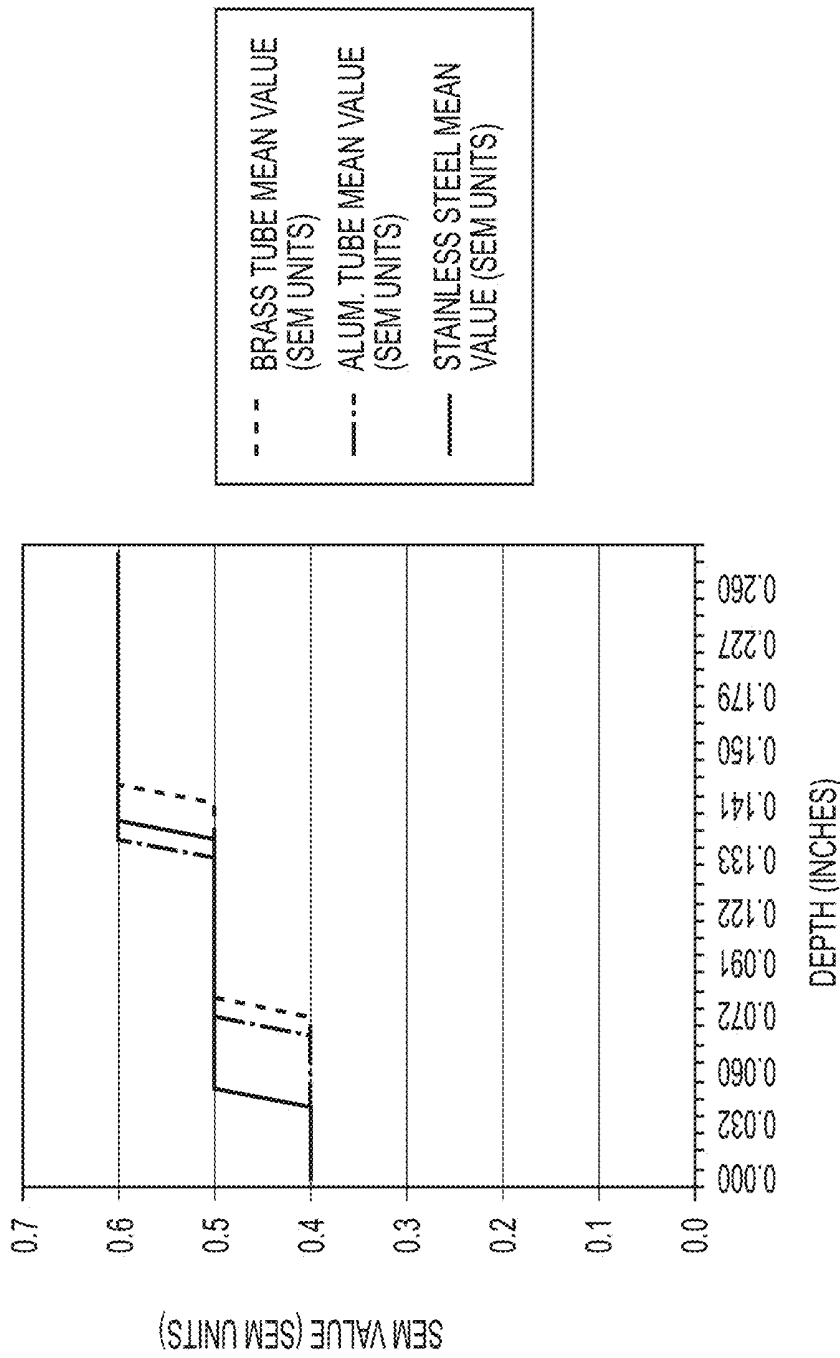


FIG. 12B

**APPARATUS AND METHODS FOR  
DETERMINING DAMAGED TISSUE USING  
SUB-EPIDERMAL MOISTURE  
MEASUREMENTS**

RELATED CASES

This application is a continuation of U.S. application Ser. No. 15/134,110, filed Apr. 20, 2016, which claims priority to U.S. Provisional Application Ser. No. 62/152,549, filed Apr. 24, 2015, the entirety of each of which is incorporated by reference herein. All references referred to herein are herein incorporated by reference in their entireties.

FIELD OF INVENTION

The present disclosure provides apparatuses and computer readable media for measuring sub-epidermal moisture in patients to determine damaged tissue for clinical intervention. The present disclosure also provides methods for determining damaged tissue.

BACKGROUND

The skin is the largest organ in the human body. It is readily exposed to different kinds of damages and injuries. When the skin and its surrounding tissues are unable to redistribute external pressure and mechanical forces, pressure ulcers may be formed. Pressure ulcers pose a significant health and economic concern internationally, across both acute and long-term care settings. Pressure ulcers impact approximately 2.5 million people a year in the United States and an equivalent number in the European Union. In long-term and critical care settings, up to 25% of elderly and immobile patients develop pressure ulcers. Approximately 60,000 U.S. patients die per year due to infection and other complications from pressure ulcers.

Most pressure ulcers occur over bony prominences, where there is less tissue for compression and the pressure gradient within the vascular network is altered. Pressure ulcers are categorized in one of four stages, ranging from the earliest stage currently recognized, in which the skin remains intact but may appear red over a bony prominence (Stage 1), to the last stage, in which tissue is broken and bone, tendon or muscle is exposed (Stage 4). Detecting pressure ulcers before the skin breaks and treating them to avoid progression to later stages is a goal of policy makers and care providers in major economies. Most pressure ulcers are preventable, and if identified before the first stage of ulceration, deterioration of the underlying tissue can be halted.

Of the four main stages of pressure ulcers, the earliest stage currently recognized (Stage 1) is the least expensive to treat at an average of \$2,000 per ulcer, but is also the hardest to detect. In many cases, injuries on the epidermis layer are not present or apparent when the underlying subcutaneous tissue has become necrotic. As a result, it is common that a clinician's first diagnosis of a pressure ulcer in a patient occurs at late stages of the ulcer development -- at which time the average cost of treatment is \$3,000 per Stage 3 ulcer, or \$129,000 per Stage 4 ulcer. If clinicians could identify and diagnose pressure ulcers at earlier stages of ulcer development, the healing process would be considerably shortened and the treatment costs would be significantly lower.

To treat pressure ulcers in a timely and effective manner, clinicians need to be able to identify, with precision, the ulceration area. However, the current standard to detect

pressure ulcers is by visual inspection, which is subjective, unreliable, untimely, and lacks specificity.

SUMMARY OF THE INVENTION

In an aspect, the present disclosure provides for, and includes, an apparatus for identifying damaged tissue. The apparatus may comprise one or more electrodes capable of interrogating tissue at and around an anatomical site, where each of the one or more electrodes may be configured to emit and receive a radiofrequency signal to generate a bioimpedance signal; a circuit that may be electronically coupled to the one or more electrodes and may be configured to convert the bioimpedance signal into a sub-epidermal moisture ("SEM") value; a processor that may be electronically coupled to the circuit and may be configured to receive the SEM value;

and a non-transitory computer readable medium that may be electronically coupled to the processor and may comprise instructions stored thereon that, when executed on the processor, may perform the steps of receiving from the processor a SEM value measured at the anatomical site and at least two SEM values measured around the anatomical site and their relative measurement locations; determining a maximum SEM value from the measurements around the anatomical site; determining a difference between the maximum SEM value and each of the at least two SEM values measured around the anatomical site; and flagging the relative measurement locations associated with a difference greater than a predetermined value as damaged tissue. In another aspect, a difference is determined between the maximum SEM value and a minimum SEM value measured around the anatomical site.

In yet another aspect, the apparatus may comprise one or more electrodes capable of interrogating tissue at and around an anatomical site, where each of the one or more electrodes may be configured to emit and receive a radiofrequency signal to generate a bioimpedance signal; a circuit that may be electronically coupled to the one or more electrodes and may be configured to convert the bioimpedance signal into a SEM value; a processor that may be electronically coupled to the circuit and may be configured to receive the SEM value; and a non-transitory computer readable medium that may be electronically coupled to the processor and may comprise instructions stored thereon that, when executed on the processor, may perform the steps of receiving from the processor a SEM value measured at the anatomical site and at least two SEM values measured around the anatomical site and their relative measurement locations; determining an average SEM value for each group of SEM values measured at approximately equidistance from the anatomical site; determining a maximum SEM value from the average SEM values; determining a difference between the maximum average SEM value and each of the average SEM values measured around the anatomical site; and flagging the relative measurement locations associated with a difference greater than a predetermined value as damaged tissue.

In yet another aspect, the present disclosure provides for, and includes, a non-transitory computer readable medium for identifying damaged tissue. The non-transitory computer readable medium may comprise instructions stored thereon, that when executed on a processor, may perform the steps of receiving a SEM value at an anatomical site and at least two SEM values measured around the anatomical site and their relative measurement locations; determining a maximum SEM value from the measurements around the anatomical site, determining a difference between the maximum SEM

value and each of the at least two SEM values measured around the anatomical site; and flagging the relative measurement locations associated with a difference greater than a predetermined value as damaged tissue. In another aspect, a difference is determined between the maximum SEM value and a minimum SEM value measured around the anatomical site.

In another aspect, the non-transitory computer readable medium may comprise instructions stored thereon that when executed on a processor, may perform the steps of receiving a SEM value at an anatomical site, and at least two SEM values measured around the anatomical site and their relative measurement locations; determining an average SEM value for each group of SEM values measured at approximately equidistance from the anatomical site; determining a maximum SEM value from the average SEM values; determining a difference between the maximum average SEM value and each of the average SEM values measured around the anatomical site; and flagging the relative measurement locations associated with a difference greater than a predetermined value as damaged tissue.

In a further aspect, the present disclosure provides for, and includes, methods for identifying damaged tissue. A method according to the present disclosure may comprise measuring at least three sub-epidermal moisture values at and around an anatomical site using an apparatus that may comprise one or more electrodes that may be capable of interrogating tissue at and around an anatomical site, wherein each of the one or more electrodes may be configured to emit and receive a radiofrequency signal to generate a bioimpedance signal; a circuit that may be electronically coupled to the one or more electrodes and configured to convert the bioimpedance signal into a SEM value; a processor that may be electronically coupled to the circuit and configured to receive the SEM value; and a non-transitory computer readable medium that may be electronically coupled to the processor and may comprise instructions stored thereon that when executed on the processor, may perform the steps of receiving from the processor a SEM value measured at the anatomical site and at least two SEM values measured around the anatomical site and their relative measurement locations; determining a maximum SEM value from the measurements around the anatomical site; determining a difference between the maximum SEM value and each of the at least two SEM values measured around the anatomical site; and flagging the relative measurement locations associated with a difference greater than a predetermined value as damaged tissue. In another aspect, a difference is determined between the maximum SEM value and a minimum SEM value measured around the anatomical site. The method may further comprise obtaining the relative measurement locations flagged as damaged tissue from the apparatus.

In another aspect, a method according to the present disclosure may comprise measuring at least three sub-epidermal moisture values at and around an anatomical site using an apparatus that may comprise one or more electrodes that may be capable of interrogating tissue at and around an anatomical site, wherein each of the one or more electrodes may be configured to emit and receive a radiofrequency signal to generate a bioimpedance signal; a circuit that may be electronically coupled to the one or more electrodes and configured to convert the bioimpedance signal into a SEM value; a processor that may be electronically coupled to the circuit and configured to receive the SEM value; and a non-transitory computer readable medium that may be electronically coupled to the processor and may

comprise instructions stored thereon that, when executed on the processor, may perform the steps of receiving from the processor a SEM value measured at the anatomical site and at least two SEM values measured around the anatomical site and their relative measurement locations; determining an average SEM value for each group of SEM values measured at approximately equidistance from the anatomical site; determining a maximum SEM value from the average SEM values; determining a difference between the maximum average SEM value and each of the average SEM values measured around the anatomical site; and flagging the relative measurement locations associated with a difference greater than a predetermined value as damaged tissue. The method may further comprise obtaining the relative measurement locations flagged as damaged tissue from the apparatus.

In a further aspect, the present disclosure provides for, and includes, methods for generating a SEM image indicating damaged tissue on an anatomical graphical representation. The SEM image may be generated by acquiring parameters of an anatomical site to be interrogated; measuring at least three sub-epidermal moisture values at and around an anatomical site using an apparatus that may comprise one or more electrodes that may be capable of interrogating tissue at and around an anatomical site, wherein each of the one or more electrodes may be configured to emit and receive a radiofrequency signal to generate a bioimpedance signal; a circuit that may be electronically coupled to the one or more electrodes and configured to convert the bioimpedance signal into a SEM value; a processor that may be electronically coupled to the circuit and configured to receive the SEM value; and a non-transitory computer readable medium that may be electronically coupled to the processor and may comprise instructions stored thereon that when executed on the processor, may perform the steps of receiving from the processor a SEM value measured at the anatomical site, and at least two SEM values measured around anatomical site and their relative measurement locations; determining a maximum SEM value from the measurements around the anatomical site, determining a difference between the maximum SEM value and each of the at least two SEM values measured around the anatomical site; and flagging the relative measurement locations associated with a difference greater than a predetermined value as damaged tissue. In another aspect, a difference is determined between the maximum SEM value and a minimum SEM value measured around the anatomical site. The method may further comprise plotting the measured SEM values in accordance with their relative measurement locations on a graphical representation of an area defined by the parameters of the anatomical site, and indicating the measurement locations that are flagged as damaged tissue.

In yet another aspect, the SEM image may be generated by acquiring parameters of an anatomical site to be interrogated; measuring at least three sub-epidermal moisture values at and around an anatomical site using an apparatus that may comprise one or more electrodes that may be capable of interrogating tissue at and around an anatomical site, wherein each of the one or more electrodes may be configured to emit and receive a radiofrequency signal to generate a bioimpedance signal; a circuit that may be electronically coupled to the one or more electrodes and configured to convert the bioimpedance signal into a SEM value; a processor that may be electronically coupled to the circuit and configured to receive the SEM value; and a non-transitory computer readable medium that may be electronically coupled to the processor and may comprise

instructions stored thereon that, when executed on the processor, may perform the steps of receiving from the processor a SEM value measured at the anatomical site, and at least two SEM values measured around anatomical site and their relative measurement locations; determining an average SEM value for each group of SEM values measured at approximately equidistance from the anatomical site; determining a maximum SEM value from the average SEM values; determining a difference between the maximum average SEM value and each of the average SEM values measured around the anatomical site; and flagging the relative measurement locations associated with a difference greater than a predetermined value as damaged tissue. The method may further comprise plotting the measured SEM values in accordance with their relative measurement locations on a graphical representation of an area defined by the parameters of the anatomical site, and indicating the measurement locations that is flagged as damaged tissue.

#### BRIEF DESCRIPTION OF THE FIGURES

Some aspects of the disclosure are herein described, by way of example only, with reference to the accompanying drawings. With specific reference now to the drawings in detail, it is stressed that the particulars shown are by way of example and are for purposes of illustrative discussion of embodiments of the disclosure. In this regard, the description, taken with the drawings, make apparent to those skilled in the art how aspects of the disclosure may be practiced.

FIG. 1—An exemplary apparatus according to the present disclosure, comprising one coaxial electrode.

FIG. 2—An exemplary sensing unit of the apparatus according to the present disclosure, comprising more than one coaxial electrode.

FIG. 3A—An exemplary coaxial electrode according to the present disclosure.

FIG. 3B—Exemplary coaxial electrodes constructed with a point source electrode surrounded by six hexagon pad electrodes according to the present disclosure.

FIG. 3C—An exemplary array of hexagon pad electrodes where each of the electrodes may be programmed to function as different parts of a coaxial electrode in accordance with the present disclosure.

FIG. 3D—Sample electronic connection of an array of hexagonal pad electrodes allowing for coaxial electrode emulation in accordance with the present disclosure.

FIG. 3E—An exemplary array of coaxial electrodes electronically coupled together.

FIG. 4—A sample measurement scheme according to the present disclosure.

FIG. 5A—Sample SEM measurement results obtained in accordance with the methods in the present disclosure, represented as a SEM map.

FIG. 5B—Sample SEM measurement results along the x-axis of FIG. 5A plotted on a graph.

FIG. 5C—Sample SEM measurement results along the y-axis of FIG. 5A plotted on a graph.

FIG. 6A—An exemplary method for taking SEM measurements starting at the posterior heel.

FIG. 6B—An exemplary method for taking SEM measurements starting at the lateral heel.

FIG. 6C—An exemplary method for taking SEM measurements starting at the medial heel.

FIG. 7A—Sample visual assessment of damaged tissue around a sacrum.

FIG. 7B—Sample SEM measurement results of damaged tissue obtained in accordance with the methods in the present disclosure.

FIG. 8A—Sample visual assessment of healthy tissue around a sacrum.

FIG. 8B—Sample SEM measurement results of healthy tissue obtained in accordance with the methods in the present disclosure.

FIG. 9A—A sample SEM map obtained in accordance with the methods in the present disclosure.

FIG. 9B—Corresponding visual assessment of damaged tissue of FIG. 9A.

FIG. 10—A sample SEM image obtained in accordance with the methods in the present disclosure.

FIG. 11—Sample time-lapsed SEM images showing the sensitivity of the detection apparatuses and methods in the present disclosure.

FIG. 12A—A sample graphical representation of a finite element model showing the depth of various SEM levels in accordance with the methods in the present disclosure.

FIG. 12B—A sample plot of SEM measurements at various depth of a skin-like material.

#### DETAILED DESCRIPTION

This description is not intended to be a detailed catalog of all the different ways in which the disclosure may be implemented, or all the features that may be added to the instant disclosure. For example, features illustrated with respect to one embodiment may be incorporated into other embodiments, and features illustrated with respect to a particular embodiment may be deleted from that embodiment. Thus, the disclosure contemplates that in some embodiments of the disclosure, any feature or combination of features set forth herein can be excluded or omitted. In addition, numerous variations and additions to the various embodiments suggested herein will be apparent to those skilled in the art in light of the instant disclosure, which do not depart from the instant disclosure. In other instances, well-known structures, interfaces, and processes have not been shown in detail in order not to unnecessarily obscure the invention. It is intended that no part of this specification be construed to effect a disavowal of any part of the full scope of the invention. Hence, the following descriptions are intended to illustrate some particular embodiments of the disclosure, and not to exhaustively specify all permutations, combinations and variations thereof.

Unless otherwise defined, all technical and scientific terms used herein have the same meaning as commonly understood by one of ordinary skill in the art to which this disclosure belongs. The terminology used in the description of the disclosure herein is for the purpose of describing particular embodiments only and is not intended to be limiting of the disclosure. All publications, patent applications, patents and other references cited herein are incorporated by reference in their entireties for the teachings relevant to the sentence and/or paragraph in which the reference is presented. References to techniques employed herein are intended to refer to the techniques as commonly understood in the art, including variations on those techniques or substitutions of equivalent techniques that would be apparent to one of skill in the art.

Unless the context indicates otherwise, it is specifically intended that the various features of the disclosure described herein can be used in any combination. Moreover, the present disclosure also contemplates that in some embodi-

ments of the disclosure, any feature or combination of features set forth herein can be excluded or omitted.

The methods disclosed herein comprise one or more steps or actions for achieving the described method. The method steps and/or actions may be interchanged with one another without departing from the scope of the present invention. In other words, unless a specific order of steps or actions is required for proper operation of the embodiment, the order and/or use of specific steps and/or actions may be modified without departing from the scope of the present invention.

As used in the description of the disclosure and the appended claims, the singular forms “a,” “an” and “the” are intended to include the plural forms as well, unless the context clearly indicates otherwise.

As used herein, “and/or” refers to and encompasses any and all possible combinations of one or more of the associated listed items, as well as the lack of combinations when interpreted in the alternative (“or”).

The terms “about” and “approximately” as used herein when referring to a measurable value such as a length, a frequency, or a SEM value and the like, is meant to encompass variations of  $\pm 20\%$ ,  $\pm 10\%$ ,  $\pm 5\%$ ,  $\pm 1\%$ ,  $\pm 0.5\%$ , or even  $\pm 0.1\%$  of the specified amount.

As used herein, phrases such as “between X and Y” and “between about X and Y” should be interpreted to include X and Y. As used herein, phrases such as “between about X and Y” mean “between about X and about Y” and phrases such as “from about X to Y” mean “from about X to about Y.”

The terms “comprise,” “comprises,” and “comprising” as used herein, specify the presence of the stated features, integers, steps, operations, elements, and/or components, but do not preclude the presence or addition of one or more other features, integers, steps, operations, elements, components, and/or groups thereof.

As used herein, the transitional phrase “consisting essentially of” means that the scope of a claim is to be interpreted to encompass the specified materials or steps recited in the claim and those that do not materially affect the basic and novel characteristic(s) of the claimed disclosure. Thus, the term “consisting essentially of” when used in a claim of this disclosure is not intended to be interpreted to be equivalent to “comprising.”

As used herein, the term “sub-epidermal moisture” refers to the increase in tissue fluid and local edema caused by vascular leakiness and other changes that modify the underlying structure of the damaged tissue in the presence of continued pressure on tissue, apoptosis, necrosis, and the inflammatory process.

As used herein, a “system” may be a collection of devices in wired or wireless communication with each other.

As used herein, “interrogate” refers to the use of radiofrequency energy to penetrate into a patient’s skin.

As used herein a “patient” may be a human or animal subject.

An exemplary apparatus according to the present disclosure is shown in FIGS. 1 and 2. It will be understood that these are examples of an apparatus for measuring sub-epidermal moisture (“SEM”). In some embodiments, the apparatus according to the present disclosure may be a handheld device, a portable device, a wired device, a wireless device, or a device that is fitted to measure a part of a human patient. U.S. Publication No. 2014/0288397 A1 to Sarrafzadeh et al. is directed to a SEM scanning apparatus, which is incorporated herein by reference in its entirety.

In certain embodiments according to the present disclosure, the apparatus may comprise one or more electrodes. In one aspect according to the present disclosure, it may be

preferable to use coaxial electrodes over electrodes such as tetrapolar ECG electrodes because coaxial electrodes are generally isotropic, which may allow SEM values to be taken irrespective of the direction of electrode placement. The SEM values measured by coaxial electrodes may also be representative of the moisture content of the tissue underneath the coaxial electrodes, rather than the moisture content of the tissue surface across two bi-polar electrodes spaced apart.

In some embodiments, the apparatus may comprise two or more coaxial electrodes, three or more coaxial electrodes, four or more coaxial electrodes, five or more coaxial electrodes, ten or more coaxial electrodes, fifteen or more coaxial electrodes, twenty or more coaxial electrodes, twenty five or more coaxial electrodes, or thirty or more coaxial electrodes. In some embodiments, the aforementioned coaxial electrodes may be configured to emit and receive an RF signal at a frequency of 32 kilohertz (kHz). In other embodiments, the coaxial electrodes may be configured to emit and receive an RF signal at a frequency of from about 5 kHz to about 100 kHz, from about 10 kHz to about 100 kHz, from about 20 kHz to about 100 kHz, from about 30 kHz to about 100 kHz, from about 40 kHz to about 100 kHz, from about 50 kHz to about 100 kHz, from about 60 kHz to about 100 kHz, from about 70 kHz to about 100 kHz, from about 80 kHz to about 100 kHz, or from about 90 kHz to about 100 kHz. In yet another embodiment, the coaxial electrodes may be configured to emit and receive an RF signal at a frequency of from about 5 kHz to about 10 kHz, from about 5 kHz to about 20 kHz, from about 5 kHz to about 30 kHz, from about 5 kHz to about 40 kHz, from about 5 kHz to about 50 kHz, from about 5 kHz to about 60 kHz, from about 5 kHz to about 70 kHz, from about 5 kHz to about 80 kHz, or from about 5 kHz to about 90 kHz. In a further embodiment, the coaxial electrodes may be configured to emit and receive an RF signal at a frequency less than 100 kHz, less than 90 kHz, less than 80 kHz, less than 70 kHz, less than 60 kHz, less than 50 kHz, less than 40 kHz, less than 30 kHz, less than 20 kHz, less than 10 kHz, or less than 5 kHz. In certain embodiments, all of the coaxial electrodes of the apparatus may operate at the same frequency. In some embodiments, some of the coaxial electrodes of the apparatus may operate at different frequencies. In certain embodiments, the frequency of a coaxial electrode may be changed through programming specific pins on an integrated circuit in which they are connected.

In some embodiments according to the present disclosure, the coaxial electrodes may comprise a bipolar configuration having a first electrode comprising an outer annular ring disposed around a second inner circular electrode. Referring to FIG. 3A, the outer ring electrode may have an outer diameter  $D_o$  and an inner diameter  $D_i$  that is larger than the diameter  $D_c$  of the circular inner electrode. Each inner circular electrode and outer electrode may be coupled electrically to one or more circuits that are capable of applying a voltage waveform to each electrode; generating a bioimpedance signal; and converting the capacitance signal to a SEM value. In certain embodiments, the bioimpedance signal may be a capacitance signal generated by, e.g., measuring the difference of the current waveform applied between the central electrode and the annular ring electrode. In some embodiments, the conversion may be performed by a 24 bit capacitance-to-digital converter. In another embodiment, the conversion may be a 16 bit capacitance-to-digital converter, a charge-timing capacitance to digital converter, a sigma-delta capacitance to digital converter. The one or

more circuits may be electronically coupled to a processor. The processor may be configured to receive the SEM value generated by the circuit.

In certain embodiments, the one or more coaxial electrodes may have the same size. In other embodiments, the one or more coaxial electrodes may have different sizes, which may be configured to interrogate the patient's skin at different depths. The dimensions of the one or more coaxial electrodes may correspond to the depth of interrogation into the derma of the patient. Accordingly, a larger diameter electrode may penetrate deeper into the skin than a smaller pad. The desired depth may vary depending on the region of the body being scanned, or the age, skin anatomy or other characteristic of the patient. In some embodiments, the one or more coaxial electrodes may be coupled to two or more separate circuits to allow independent operation of each of the coaxial electrodes. In another embodiment, all, or a subset, of the one or more coaxial electrodes may be coupled to the same circuit.

In some embodiments, the one or more coaxial electrodes may be capable of emitting RF energy to a skin depth of 4 millimeters (mm), 3.5 mm, 3.0 mm, 2.5 mm, 2.0 mm, 1.0 mm, or 0.5 mm. In a further embodiment, the one or more coaxial electrodes may have an outer diameter  $D_o$  from about 5 mm to about 55 mm, from about 10 mm to about 50 mm, from about 15 mm to about 45 mm, or from about 20 mm to about 40 mm. In another embodiment, the outer ring of the one or more coaxial electrodes may have an inner diameter  $D_i$  from about 4 mm to about 40 mm, from about 9 mm to about 30 mm, or from about 14 mm to about 25 mm. In yet another embodiment, the inner electrode of the one or more coaxial electrodes may have a diameter  $D_c$  from about 2 mm to 7 mm, 3 mm to 6 mm, or 4 mm to 5 mm. In a further embodiment, the one or more coaxial electrodes may be spaced apart at a distance to avoid interference between the electrodes. The distance may be a function of sensor size and frequency to be applied. In some embodiments, each of the one or more coaxial electrodes may be activated sequentially. In certain embodiments, multiple coaxial electrodes may be activated at the same time.

In certain embodiments according to the present disclosure, a coaxial electrode may comprise a point source surrounded by hexagon pad electrodes spaced at approximately equidistance, as illustrated in FIG. 3B. The point source may comprise a hexagon pad electrode. In some embodiments, the point source may comprise two, three, four, five, or six hexagon pad electrodes. In certain embodiments, a point source may be surrounded by six hexagon pad electrodes. In some embodiments, multiple coaxial electrodes may be emulated from an array comprising a plurality of hexagon pad electrodes, where each hexagon pad electrode may be programmed to be electronically coupled to a floating ground, a capacitance input, or a capacitance excitation signal, as illustrated in FIGS. 3C and 3D. In a further embodiment, each of the hexagon pad electrodes may be connected to a multiplexer that may have a select line that controls whether the hexagon pad electrode is connected to a capacitance input or a capacitance excitation signal. The multiplexer may also have an enable line that controls whether to connect the hexagon pad electrode to a floating ground. In certain embodiments, the multiplexer may be a pass-gate multiplexer. In some embodiments, the one or more coaxial electrodes may be arranged as illustrated in FIG. 3E to leverage multiplexer technology. Without being limited to theory, the arrangement illustrated in FIG. 3E may limit interference between the one or more coaxial electrodes.

In certain embodiments, one or more coaxial electrodes may be embedded on a first side of a non-conductive substrate. In some embodiments, the substrate may be flexible or hard. In certain embodiments, the flexible substrate may comprise kapton, polyimide, or a combination thereof. In further embodiments, an upper coverlay may be positioned directly above the one or more coaxial electrodes. In certain embodiments, the upper coverlay may be a double-sided, copper-clad laminate and an all-polyimide composite of a polyimide film bonded to copper foil. In some embodiments, the upper coverlay may comprise Pyralux 5 mil FR0150. Without being limited by theory, the use of this upper coverlay may avoid parasitic charges naturally present on the skin surface from interfering with the accuracy and precision of SEM measurements. In some embodiments, the one or more coaxial electrodes may be spring mounted to a substrate within an apparatus according to the present disclosure.

In some embodiments, the apparatus may comprise a non-transitory computer readable medium electronically coupled to the processor. In certain embodiments, the non-transitory computer readable medium may comprise instructions stored thereon that, when executed on a processor, may perform the steps of: (1) receiving at least one SEM value at an anatomical site; (2) receiving at least two SEM values measured around the anatomical site and their relative measurement locations; (3) determining a maximum SEM value from the measurements around the anatomical site; (4) determining a difference between the maximum SEM value and each of the at least two SEM values measured around the anatomical site; and (5) flagging the relative measurement locations associated with a difference greater than a predetermined value as damaged tissue. In another embodiment, the non-transitory computer readable medium may comprise instructions stored thereon that may carry out the following steps when executed by the processor: (1) receiving at least one SEM value measured at an anatomical site; (2) receiving at least two SEM values measured around the anatomical site, and their relative measurement locations; (3) determining an average SEM value for each group of SEM values measured at approximately equidistance from the anatomical site; (4) determining a maximum SEM value from the average SEM values; (5) determining a difference between the maximum average SEM value and each of the average SEM values measured around the anatomical site; and (6) flagging the relative measurement locations associated with a difference greater than a predetermined value as damaged tissue. In yet another embodiment, the non-transitory computer readable medium may comprise instructions stored thereon that, when executed on a processor, may perform the steps of: (1) receiving at least one SEM value at an anatomical site; (2) receiving at least two SEM values measured around the anatomical site and their relative measurement locations; (3) determining a maximum SEM value from the measurements around the anatomical site; (4) determining a minimum SEM value from the measurements around the anatomical site; (5) determining a difference between the maximum SEM value and the minimum SEM value;

and (6) flagging the relative measurement locations associated with a difference greater than a predetermined value as damaged tissue. In some embodiments, the predetermined value may be 0.3, 0.35, 0.4, 0.45, 0.5, 0.55, 0.6, 0.65, 0.7, 0.75, 0.8, 0.85, 0.9, 0.95, 1.0, 1.1, 1.2, 1.3, 1.4, 1.5, 1.6, 1.7, 1.8, 1.9, 2.0, 2.1, 2.2, 2.3, 2.4, 2.5, 2.6, 2.7, 2.8, 2.9, 3.0, 3.1, 3.2, 3.3, 3.4, 3.5, 3.6, 3.7, 3.8, 3.9, 4.0, 4.1, 4.2, 4.3, 4.4, 4.5, 4.6, 4.7, 4.8, 4.9, 5.0, 5.1, 5.2, 5.3, 5.4, 5.5, 5.6, 5.7, 5.8, 5.9,

6.0, 6.1, 6.2, 6.3, 6.4, 6.5, 6.6, 6.7, 6.8, 6.9, 7.0, 7.1, 7.2, 7.3, 7.4, or 7.5. It will be understood that the predetermined value is not limited by design, but rather, one of ordinary skill in the art would be capable of choosing a predetermined value based on a given unit of SEM.

In further embodiments, the leading edge of inflammation may be indicated by an SEM difference that is equal to or greater than the predetermined value. In some embodiments, the leading edge of inflammation may be identified by the maximum values out of a set of SEM measurements.

In certain embodiments, an anatomical site may be a bony prominence. In further embodiments, an anatomical site may be a sternum, sacrum, a heel, a scapula, an elbow, an ear, or other fleshy tissue. In some embodiments, one SEM value is measured at the anatomical site. In another embodiment, an average SEM value at the anatomical site is obtained from two, three, four, five, six, seven, eight, nine, ten, or more than ten SEM values measured at the anatomical site.

The apparatuses of the present disclosure may allow the user to control the pressure applied onto a patient's skin to allow for optimized measurement conditions. In certain embodiments, a first pressure sensor may be placed on a second side opposing the first side of the substrate that the coaxial electrodes are disposed on. In a further embodiment, a second pressure sensor may be disposed on a second side opposing the first side of the substrate that the coaxial electrodes are disposed on. In certain embodiments, the first pressure sensor may be a low pressure sensor, and the second pressure sensor may be a high pressure sensor. Together, the first and second pressure sensors may allow measurements to be taken at a predetermined range of target pressures. In some embodiments, a target pressure may be about 500 g. It will be understood that the high and low pressure sensors are not limited by design, but rather, one of ordinary skill in the art would be capable of choosing these sensors based on a given range of target pressures. The first and second pressure sensors may be resistive pressure sensors. In some embodiments, the first and second pressure sensors may be sandwiched between the substrate and a conformal pressure pad. The conformal pressure pad may provide both support and conformity to enable measurements over body curvature and bony prominences.

In an embodiment, the apparatus may further comprise a plurality of contact sensors on the same planar surface as, and surrounding, each of the one or more coaxial electrodes to ensure complete contact of the one or more coaxial electrodes to the skin surface. The plurality of contact sensors may be a plurality of pressure sensors, a plurality of light sensors, a plurality of temperature sensors, a plurality of pH sensors, a plurality of perspiration sensors, a plurality of ultrasonic sensors, a plurality of bone growth stimulator sensors, or a plurality of a combination of these sensors. In some embodiments, the plurality of contact sensors may comprise four, five, six, seven, eight, nine, or ten or more contact sensors surrounding the one or more coaxial electrodes.

In certain embodiments, the apparatus may comprise a temperature probe. In some embodiments, the temperature probe may be a thermocouple or an infrared thermometer.

In some embodiments, the apparatus may further comprise a display having a user interface. The user interface may allow the user to input measurement location data. The user interface may further allow the user to view measured SEM values and/or damaged tissue locations. In certain embodiments, the apparatus may further comprise a transceiver circuit configured to receive data from and transmit data to a remote device, such as a computer, tablet or other

mobile or wearable device. The transceiver circuit may allow for any suitable form of wired or wireless data transmission such as, for example, USB, Bluetooth, or Wifi.

Methods according to the present disclosure provide for identifying damaged tissue. In some embodiments, the method may comprise measuring at least three SEM values at and around an anatomical site using an apparatus of the present invention, and obtaining from the apparatus measurement locations that are flagged as damaged tissue. In certain embodiments, measurements may be taken at positions that are located on one or more concentric circles about an anatomic site. FIG. 4 provides a sample measurement strategy, with the center being defined by an anatomic site. In another embodiment, the measurements may be taken spatially apart from an anatomic site. In yet another embodiment, the measurements may be taken on a straight line across an anatomic site. In a further embodiment, the measurements may be taken on a curve around an anatomic site. In certain embodiment, surface moisture and matter above a patient's skin surface may be removed prior to the measuring step. In some embodiments, the measuring step may take less than one second, less than two seconds, less than three seconds, less than four seconds, or less than five seconds.

Having now generally described the invention, the same will be more readily understood through reference to the following examples that are provided by way of illustration, and are not intended to be limiting of the present disclosure, unless specified.

## EXAMPLES

### Example 1

#### Measuring Sub-Epidermal Moisture (SEM) Values at the Bony Prominence of the Sacrum

Subjects with visually-confirmed Stage I or II pressure ulcers with unbroken skin were subjected to multiple SEM measurements at and around the bony prominence of the sacrum using an apparatus of this disclosure. Prior to performing the measurements, surface moisture and matter above the subjects' skin surface were removed. An electrode of the apparatus was applied to the desired anatomical site with sufficient pressure to ensure complete contact for approximately one second. Additional measurements were taken at the mapped location as laid out in FIG. 4.

FIG. 5A shows a sample SEM map centered on an anatomical site. FIG. 5B is a plot of the individual SEM values across the x-axis of the SEM map. FIG. 5C is a plot of the individual SEM values across the y-axis of the SEM map. Damaged tissue radiated from the center anatomical site to an edge of erythema defined by a difference in SEM values of greater than 0.5.

### Example 2

#### Taking SEM Measurements at the Bony Prominence of the Heel

SEM measurements were taken at the heel using one of three methods below to ensure complete contact of an electrode with the skin of a human patient.

FIG. 6A illustrates a method used to take SEM measurements starting at the posterior heel using an apparatus according to the present disclosure. First, the forefoot was dorsiflexed such that the toes were pointing towards the shin.

## 13

Second, an electrode was positioned at the base of the heel. The electrode was adjusted for full contact with the heel, and multiple SEM measurements were then taken in a straight line towards the toes.

FIG. 6B illustrates a method used to take SEM measurements starting at the lateral heel using an apparatus according to the present disclosure. First, the toes were pointed away from the body and rotated inward towards the medial side of the body. Second, an electrode was placed on the lateral side of the heel. The electrode was adjusted for full contact with the heel, and multiple SEM measurements were taken in a straight line towards the bottom of the foot.

FIG. 6C illustrates a method used to take SEM measurements starting at the medial heel using an apparatus according to the present disclosure. First, the toes were pointed away from the body and rotated outwards toward the lateral side of the body. Second, the electrode was placed on the medial side of the heel. The electrode was adjusted for full contact with the heel, and multiple measurements were taken around the back of the heel in a curve.

## Example 3

## Identifying a Region of Damaged Tissue

SEM measurements were taken on a straight line, each spaced apart by 2 cm, across the sacrum of a patient. Multiple measurements were taken at a given measurement location. FIG. 7A is a sample visual assessment of damaged tissue. FIG. 7B is a corresponding plot of the averages of SEM measurements taken at each location. The edges of erythema are defined by differences in SEM values of greater than 0.5.

## Example 4

## SEM Measurements of Healthy Tissue

SEM measurements were taken on a straight line across the sacrum of a patient. Multiple measurements were taken at a given measurement location. FIG. 8A is a sample visual assessment of healthy tissue. FIG. 8B is a corresponding plot of the averages of SEM measurements taken at each location. The tissue is defined as healthy as the differences in SEM values are all less than 0.5.

## Example 5

## SEM Measurement Map of Damaged Tissue

SEM measurements were taken in accordance with Example 1. FIG. 9A is a sample map of averaged SEM values taken on concentric rings around an anatomical site. FIG. 9B is the corresponding visual assessment of the patient's skin. Compromised tissue is identified by the solid circle, where the difference in SEM values compared to the maximum SEM value is greater than 0.5. The leading edge of inflammation is identified by the dotted circle, where the difference in SEM values compared to the maximum SEM value is equal to or greater than 0.5. The leading edge of inflammation is identified by a dotted line, indicating the largest values in the SEM map.

## Example 6

## Sample SEM Measurement Image Representations

SEM measurements were taken with an array of coaxial electrodes. FIG. 10 is a sample output of a SEM measure-

## 14

ment image showing the moisture content of the skin over a defined area. Different SEM values are indicated by different colors.

## Example 7

## SEM Measurements of Skin Moisture Content Over Time

Moisturizer was used to simulate the onset of a pressure ulcer. 0.2 mL moisturizer was applied to the inner forearm of a subject for 60 seconds. The moisturizer was then wiped from the skin. SEM measurements were taken with an array of coaxial electrodes every 10 minutes for 2 hours. FIG. 11 shows a sample time lapse of an SEM measurement image to monitor moisture content of a test subject.

## Example 8

## Selecting an Optimal Electrode for Interrogating Patient Skin

FIG. 12A is a sample graphical representation of a finite element model showing the depth of various SEM levels in accordance with the methods in the present disclosure. Each line indicates a SEM value and the depth of the moisture content.

Actual SEM levels in various depths of a skin-like material were measured using an apparatus according to the present disclosure. Specifically, the apparatus comprises one coaxial electrode. First, the thickness of a blister bandage, which simulates a skin-like material, was measured and placed on the coaxial electrode. A downward force was then applied via a metal onto the coaxial electrode, in an acceptable range according to the present disclosure. The metal is fitted to a second metal in tubular form. The second metal was selected from brass, aluminum, and stainless steel. The SEM measurement was recorded. Additional blister bandages were placed atop the coaxial electrodes for further SEM measurement recordings. FIG. 12B is a sample plot of SEM measurements at various thicknesses of the blister bandages. Without being limited by theory, the variations in the SEM values in the presence of different tubular metal may be due to potential magnetic field interference. The maximum depth of a magnetic field generated by the coaxial sensor was determined by the distance from the coaxial sensor when the metal tube no longer interfered with the magnetic field. In this example, the maximum depth ranged from 0.135 inches to 0.145 inches. Accordingly, electrodes having an optimal penetration depth could be selected to interrogate specific depths of patient skin.

While the invention has been described with reference to particular embodiments, it will be understood by those skilled in the art that various changes may be made and equivalents may be substituted for elements thereof without departing from the scope of the invention. In addition, many modifications may be made to a particular situation or material to the teachings of the invention without departing from the scope of the invention.

Therefore, it is intended that the invention not be limited to the particular embodiments disclosed as the best mode contemplated for carrying out this invention, but that the invention will include all embodiments falling within the scope and spirit of the appended claims.

The invention claimed is:

1. An apparatus for assessing tissue health, said apparatus comprising:

15

one or more coaxial sensors capable of interrogating tissue at and around an anatomical site, wherein each of said one or more coaxial sensors is configured to generate a bioimpedance signal;

a circuit electronically coupled to said one or more coaxial sensors and configured to convert said bioimpedance signal into a sub-epidermal moisture (SEM) value, the SEM value corresponding to moisture content of a location around the anatomical site;

a processor electronically coupled to said circuit and configured to receive said SEM value; and

a non-transitory computer-readable medium electronically coupled to said processor and comprising instructions stored thereon that, when executed on said processor, perform the steps of:

receiving at least two of said SEM values from different locations around the anatomical site of a patient;

determining a maximum SEM value and a minimum SEM value from said received SEM values;

determining a delta difference between said maximum SEM value and said minimum SEM value, wherein said delta difference is an indicator related to tissue health.

2. The apparatus of claim 1, further comprising a visual display coupled to said processor, wherein said instructions further comprise a step to provide said delta difference on said display.

3. The apparatus of claim 1, further comprising a substrate, and wherein said one or more coaxial sensors are embedded on a first side of said substrate.

4. The apparatus of claim 3, wherein said substrate is flexible.

5. The apparatus of claim 3, wherein said substrate is rigid.

6. The apparatus of claim 1, further comprising a second circuit configured to receive and transmit data to a remote device.

7. The apparatus of claim 1, further comprising a temperature probe.

8. An apparatus for assessing tissue health, said apparatus comprising:

16

one or more coaxial sensors capable of interrogating tissue at and around an anatomical site, wherein each of said one or more coaxial sensors is configured to generate a bioimpedance signal;

a circuit electronically coupled to said one or more coaxial sensors and configured to convert said bioimpedance signal into a sub-epidermal moisture (SEM) value, the SEM value corresponding to moisture content of a location around the anatomical site;

a processor electronically coupled to said circuit and configured to receive said SEM value; and

a non-transitory computer-readable medium electronically coupled to said processor and comprising instructions stored thereon that, when executed on said processor, perform the steps of:

receiving at least two of said SEM values from different locations around the anatomical site of a patient;

determining an average of said received SEM values;

and

determining a delta difference between one of said received SEM values and said average SEM value, wherein said delta difference is an indicator related to tissue health.

9. The apparatus of claim 8, wherein said instructions further comprise:

determining a maximum SEM value from said received SEM values; and

determining said delta difference between said maximum SEM value and said average SEM value.

10. The apparatus of claim 8, wherein said instructions further comprise:

determining delta differences between each of said received SEM values and said average SEM value.

11. The apparatus of claim 1, wherein the instructions stored on said processor require receipt of at least three SEM values from different locations prior to determining said maximum and minimum SEM values from said received SEM values.

\* \* \* \* \*

专利名称(译)	使用表皮下水分测量来确定受损组织的装置和方法		
公开(公告)号	<a href="#">US10178961</a>	公开(公告)日	2019-01-15
申请号	US15/273202	申请日	2016-09-22
申请(专利权)人(译)	BRUIN BIOMETRICS LLC		
当前申请(专利权)人(译)	BRUIN生物识别, LLC		
[标]发明人	TONAR YA CHEN RHODES SHANNON CLENDENIN MARTA BURNS MARTIN JARADEH KINDAH		
发明人	TONAR, YA-CHEN RHODES, SHANNON CLENDENIN, MARTA BURNS, MARTIN JARADEH, KINDAH		
IPC分类号	A61B5/053 A61B5/00 A61B5/04		
CPC分类号	A61B5/0537 A61B5/0531 A61B5/445 A61B5/447 A61B5/4875 A61B5/7278 A61B5/742 A61B5/746 A61B5/6801 A61B2562/046 A61B5/6843 A61B2560/0468		
代理人(译)	MARSH, DAVID		
优先权	62/152549 2015-04-24 US		
其他公开文献	US20170007153A1		
外部链接	<a href="#">Espacenet</a>		

摘要(译)

本公开提供了用于测量患者中的表皮下水分以确定用于临床干预的受损组织的装置和计算机可读介质。本公开还提供了用于确定受损组织的方法。

