



US009946457B2

(12) **United States Patent**  
**Warren**

(10) **Patent No.:** **US 9,946,457 B2**  
(45) **Date of Patent:** **Apr. 17, 2018**

- (54) **WEARABLE ELECTRONIC DEVICE WITH INTERFACE**
- (71) Applicant: **Apollo 13 Designs, LLC**, Lancaster, PA (US)
- (72) Inventor: **Michael K. Warren**, Lancaster, PA (US)
- (73) Assignee: **Apollo 13 Designs, LLC**, Lancaster, PA (US)

(\* ) Notice: Subject to any disclaimer, the term of this patent is extended or adjusted under 35 U.S.C. 154(b) by 0 days.

(21) Appl. No.: **15/262,758**

(22) Filed: **Sep. 12, 2016**

(65) **Prior Publication Data**

US 2017/0068437 A1 Mar. 9, 2017

**Related U.S. Application Data**

(63) Continuation-in-part of application No. 14/179,097, filed on Feb. 12, 2014, and a continuation-in-part of (Continued)

(51) **Int. Cl.**

- G08B 23/00** (2006.01)
- G06F 3/0488** (2013.01)
- H04W 4/00** (2018.01)
- A61B 5/0205** (2006.01)
- A61B 5/00** (2006.01)
- G05B 19/048** (2006.01)
- G06Q 20/32** (2012.01)
- G06K 7/10** (2006.01)
- G06F 3/16** (2006.01)
- G06F 3/0346** (2013.01)
- G06F 3/044** (2006.01)

(Continued)

- (52) **U.S. Cl.**  
CPC ..... **G06F 3/04883** (2013.01); **A44C 17/0233** (2013.01); **A61B 5/02055** (2013.01); **A61B 5/6817** (2013.01); **G05B 19/048** (2013.01); **G06F 3/0346** (2013.01); **G06F 3/044** (2013.01); **G06F 3/162** (2013.01); **G06K 7/10297** (2013.01); **G06Q 20/322** (2013.01); **H04W 4/008** (2013.01); **A44C 9/00** (2013.01); **A61B 5/02438** (2013.01); **G05B 2219/35444** (2013.01); **G06F 2203/0384** (2013.01); **H04L 41/026** (2013.01); **H04W 68/005** (2013.01)

(58) **Field of Classification Search**  
None  
See application file for complete search history.

(56) **References Cited**

**U.S. PATENT DOCUMENTS**

- 6,715,911 B2 4/2004 Villarreal
  - 7,040,778 B2 5/2006 Villarreal
- (Continued)

**OTHER PUBLICATIONS**

Webpage for [www.Ringly.com](http://www.Ringly.com), downloaded on Dec. 6, 2016, Copyright 2016 Ringly, 4 pages.

*Primary Examiner* — Adolf Dsouza

(74) *Attorney, Agent, or Firm* — Barley Snyder

(57) **ABSTRACT**

A wearable electronic device is disclosed. The wearable electronic device comprises a ring body and a substrate. The ring body has an outer cover and an interface disposed on an exterior of the outer cover, with the ring body defining an annular receiving space within the ring body. The substrate is disposed in the annular receiving space and has a plurality of capacitive plates.

**42 Claims, 22 Drawing Sheets**

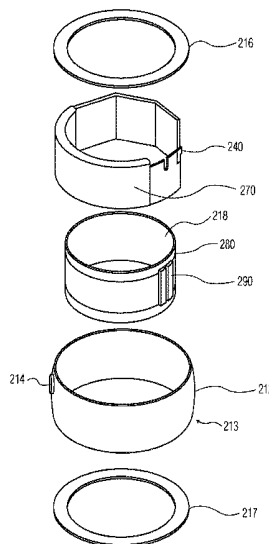

**Related U.S. Application Data**

application No. 13/827,341, filed on Mar. 14, 2013,  
now abandoned.

(51) **Int. Cl.**

*A44C 17/02* (2006.01)  
*H04W 4/14* (2009.01)  
*H04L 12/24* (2006.01)  
*H04W 68/00* (2009.01)  
*A61B 5/024* (2006.01)  
*A44C 9/00* (2006.01)

(56) **References Cited**

U.S. PATENT DOCUMENTS

7,513,019 B2 4/2009 Friedman  
8,250,796 B2 8/2012 Padgett  
2008/0074329 A1\* 3/2008 Caballero ..... H01Q 1/088  
343/702  
2012/0249797 A1\* 10/2012 Haddick ..... G06F 1/163  
348/158  
2013/0191741 A1\* 7/2013 Dickinson ..... G06F 1/163  
715/702  
2013/0327088 A1 12/2013 Smith  
2014/0027521 A1 1/2014 Pedicano

\* cited by examiner

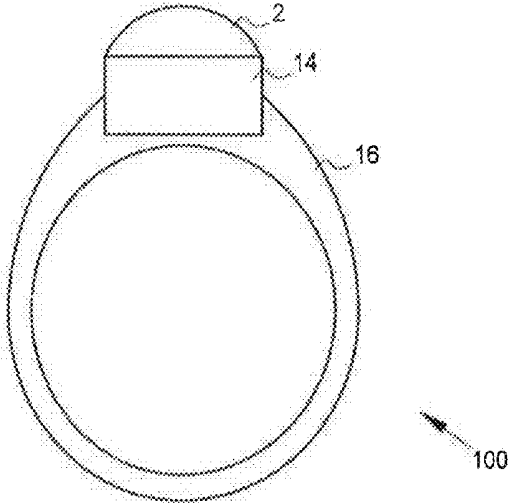

FIG. 1

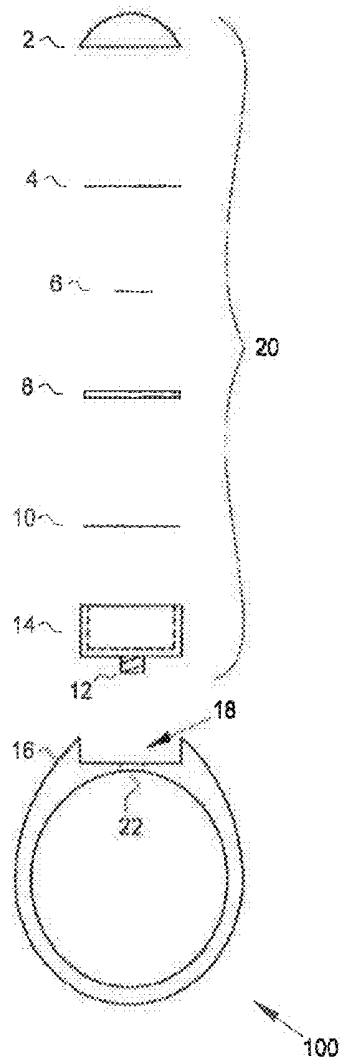

FIG. 2

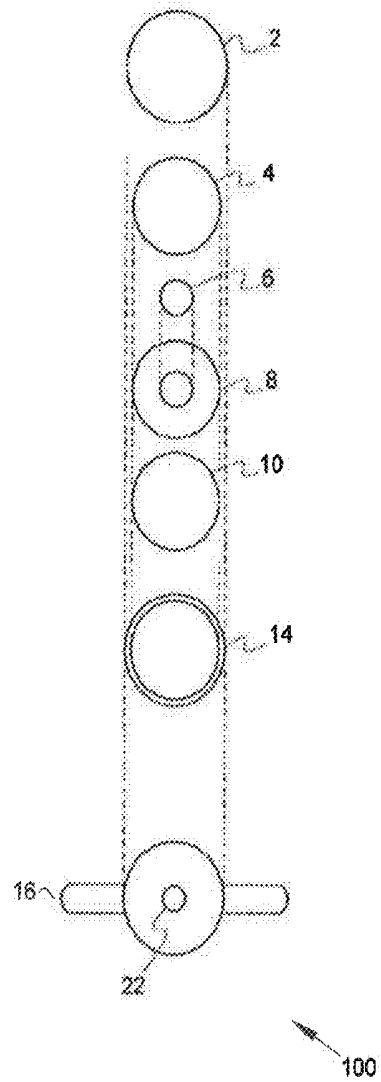

FIG. 3

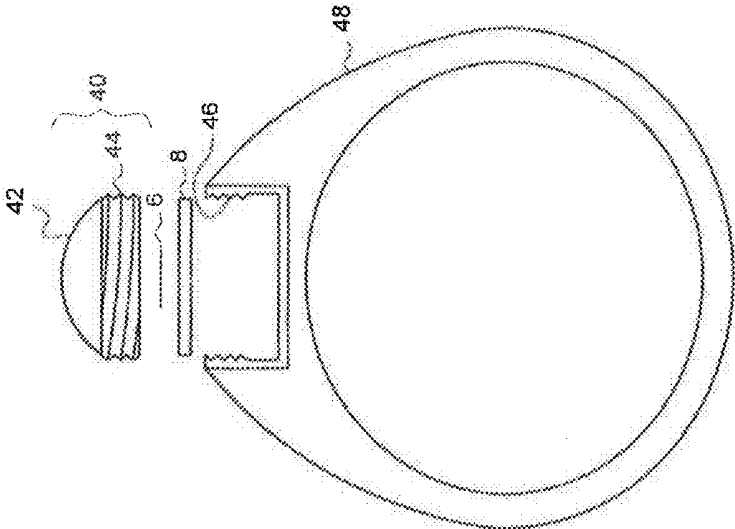

FIG. 4

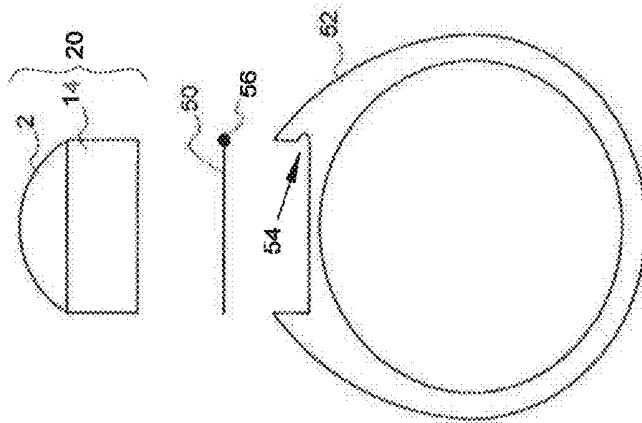

FIG. 5

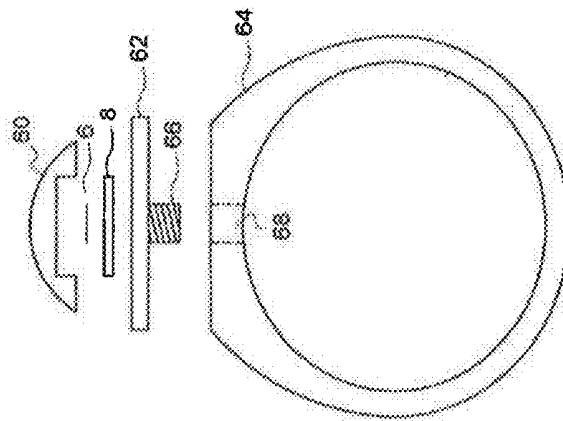

FIG. 6

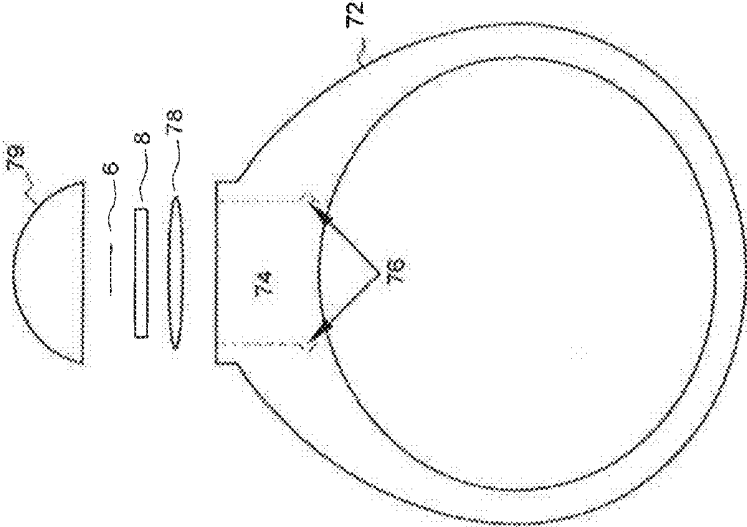

FIG. 7

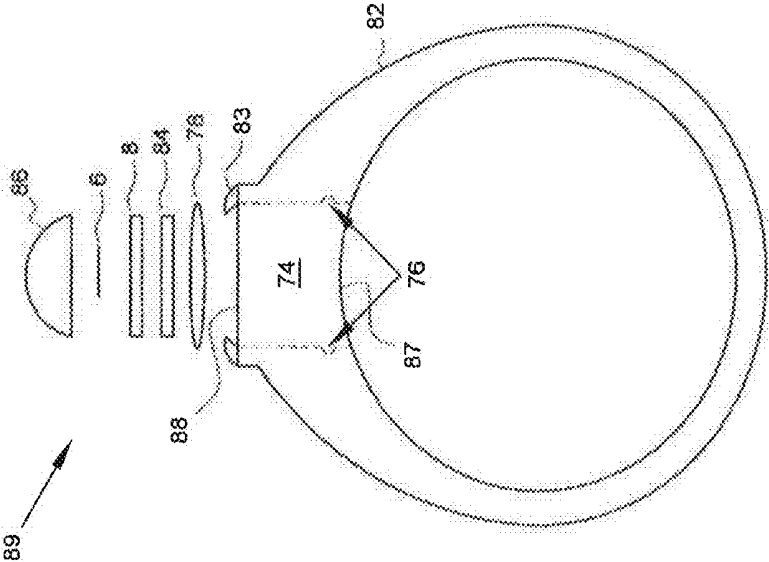

FIG. 8A

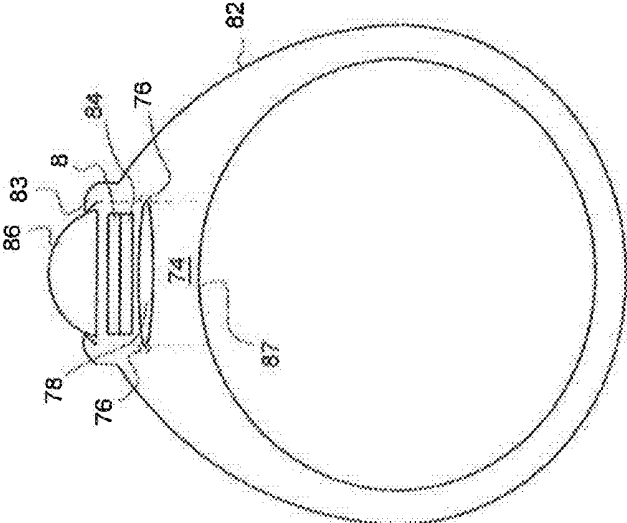

FIG. 8B

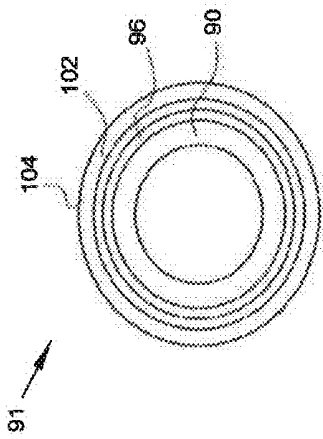

FIG. 9C

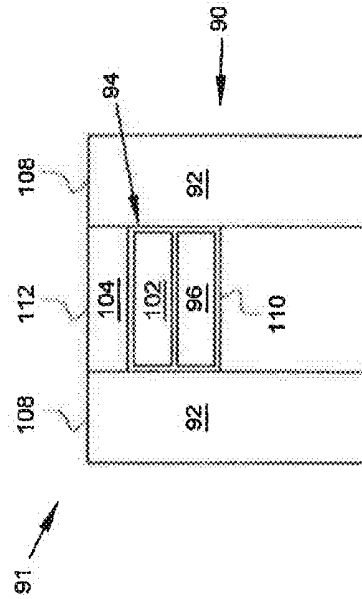

FIG. 9D

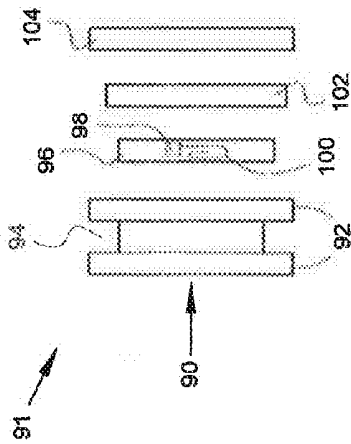

FIG. 9A

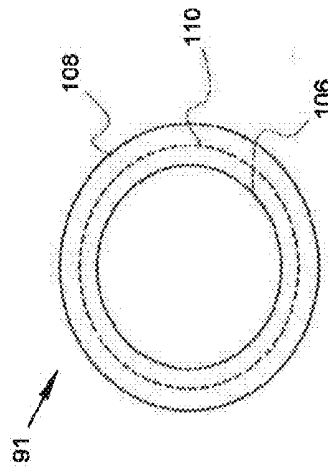

FIG. 9B

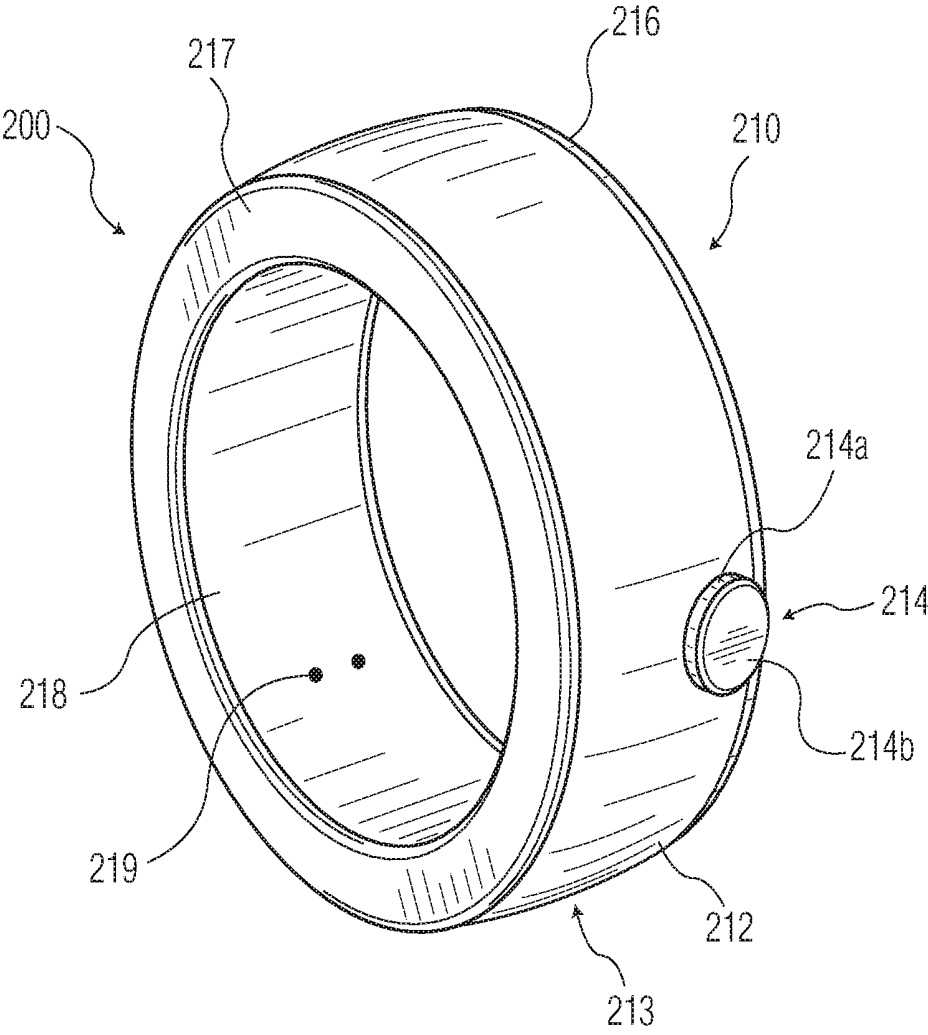

FIG. 10

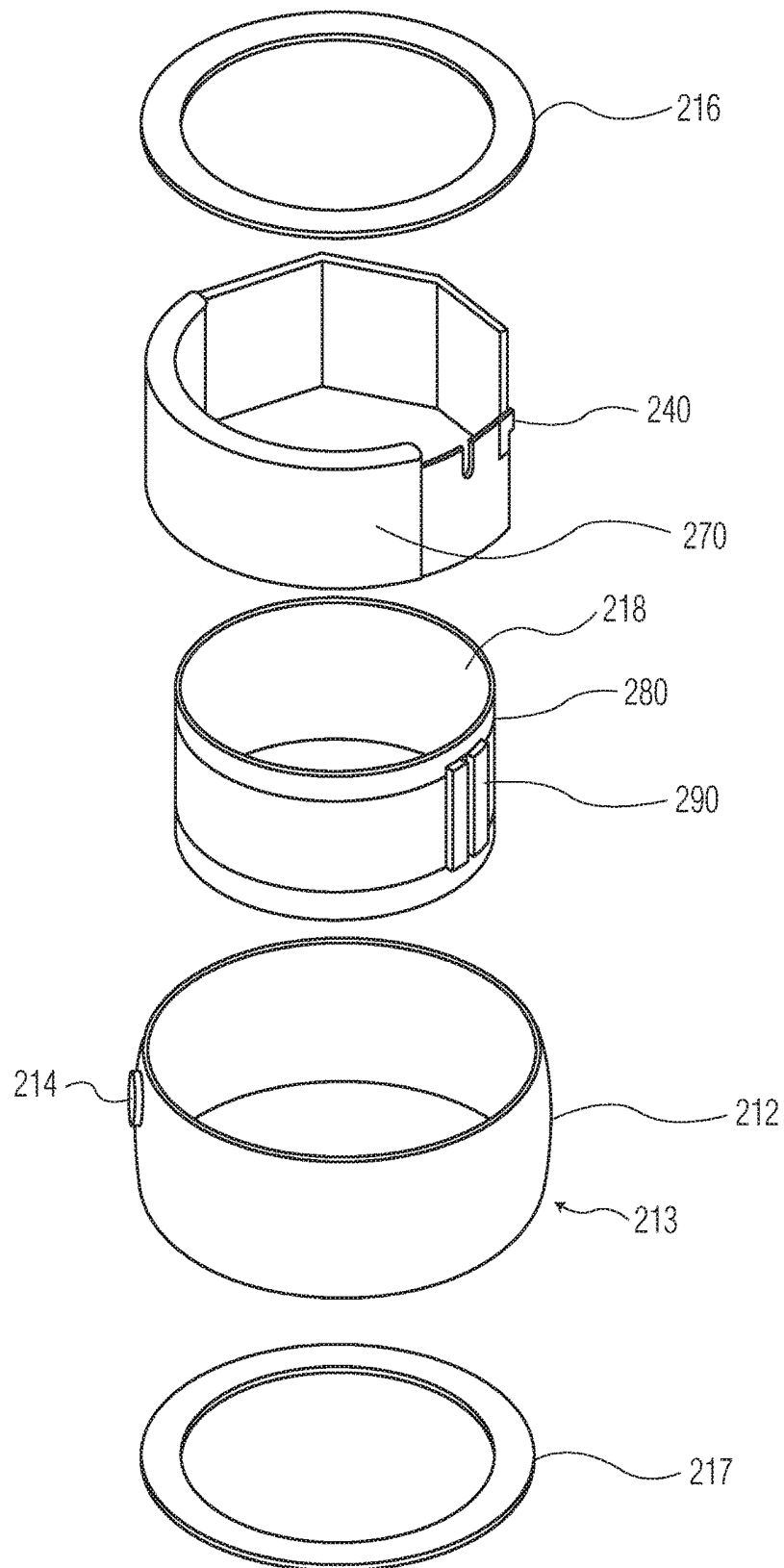

FIG. 11

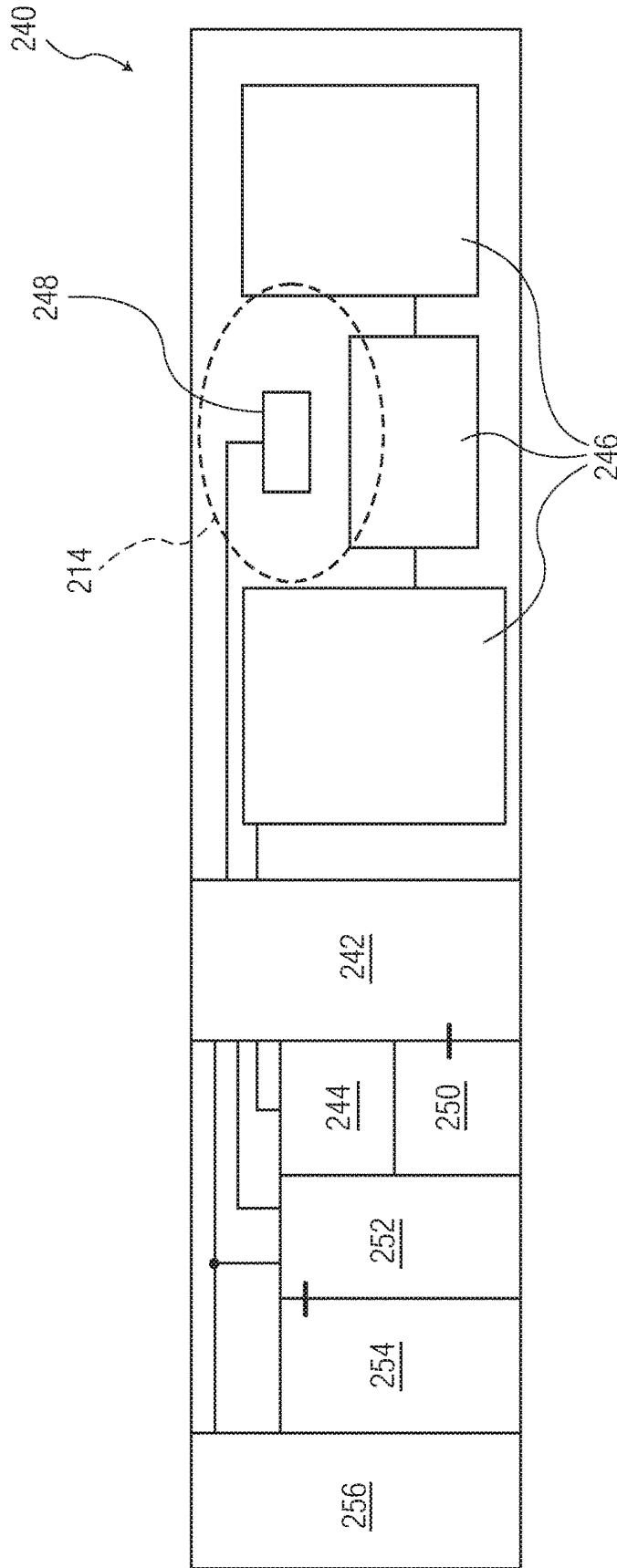

FIG. 12

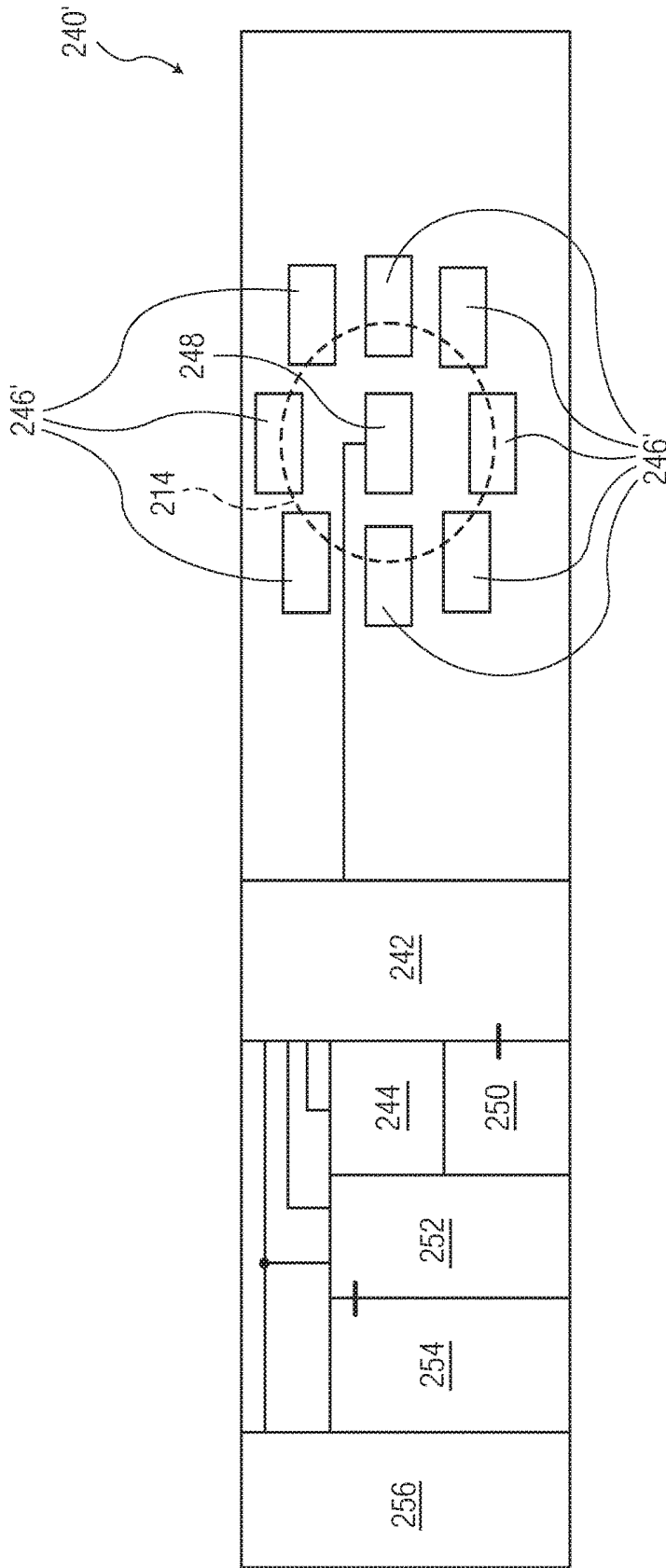

FIG. 13

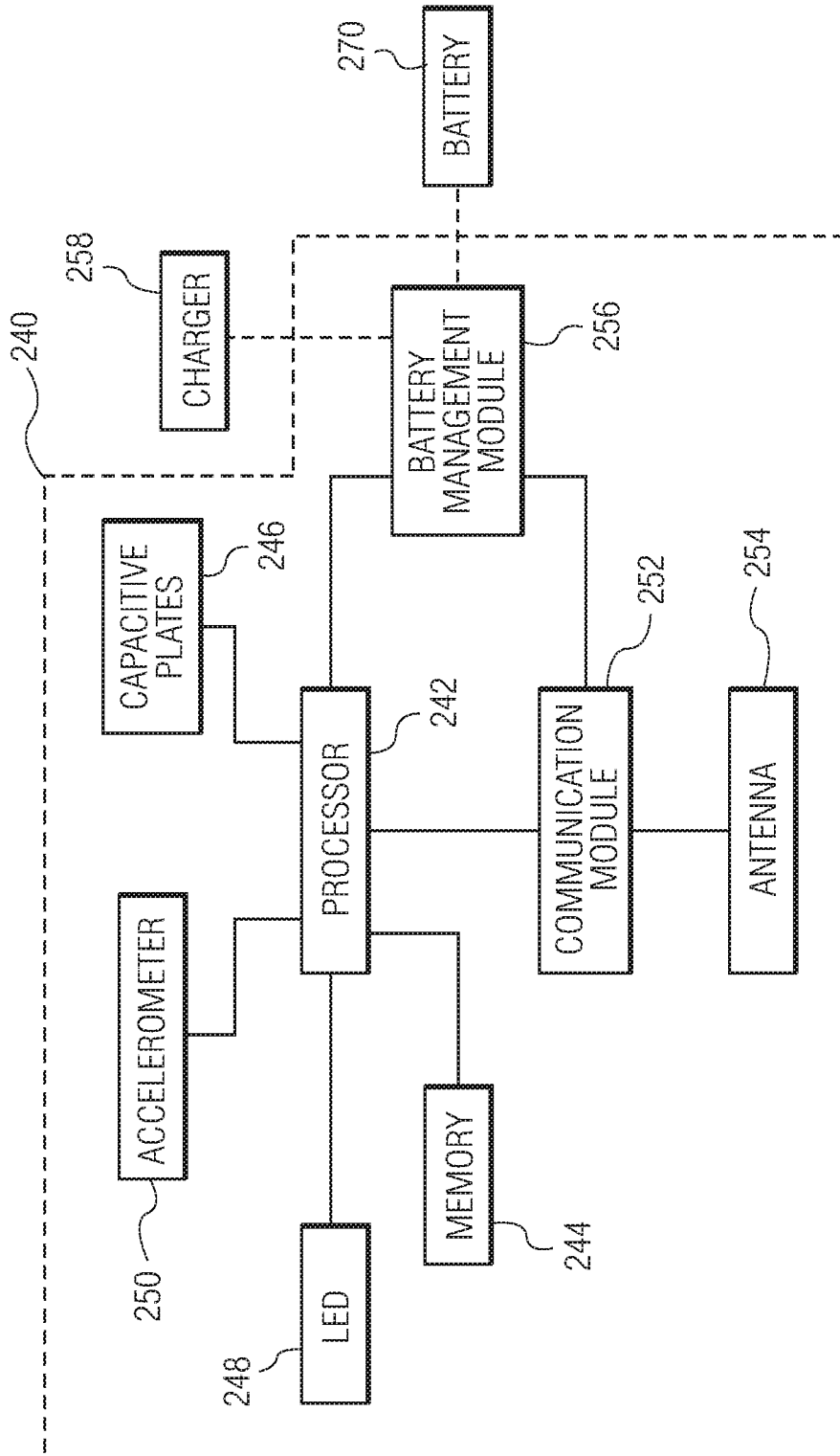

FIG. 14

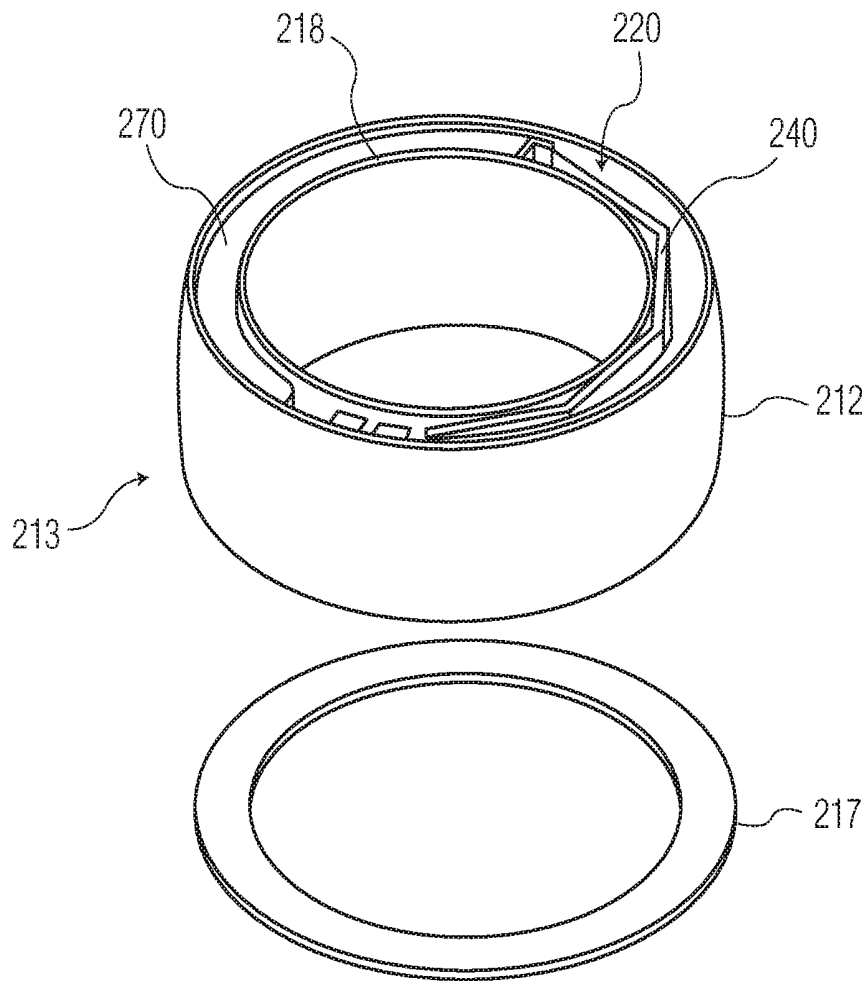

FIG. 15

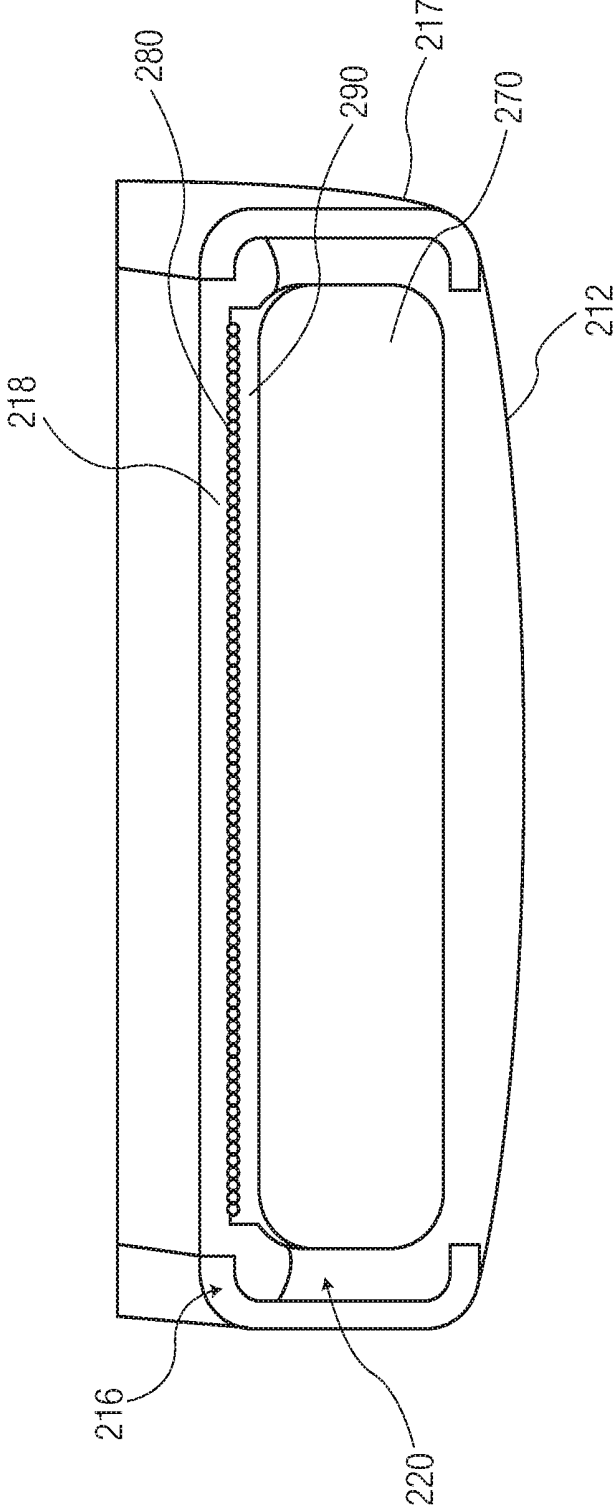

FIG. 16

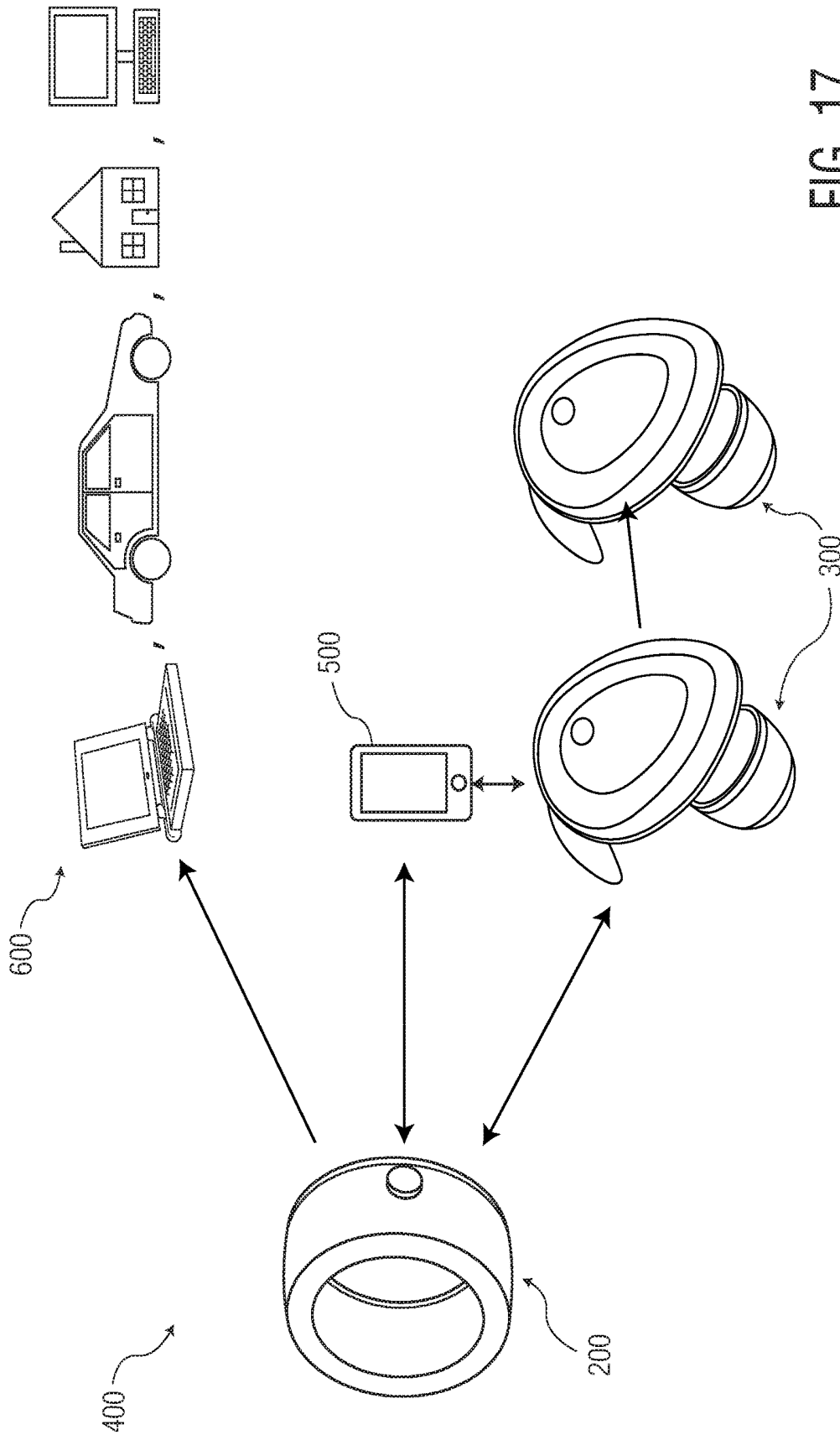

FIG. 17

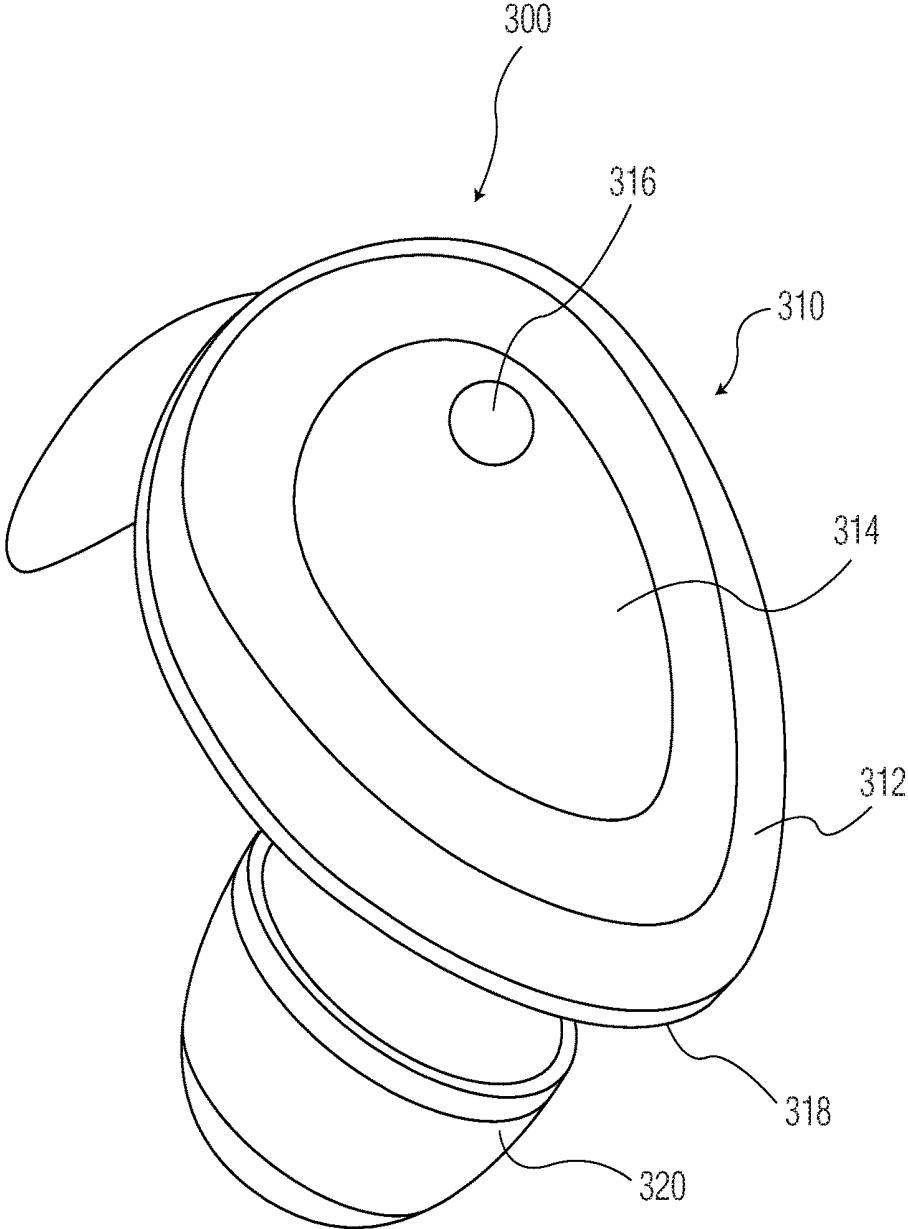

FIG. 18

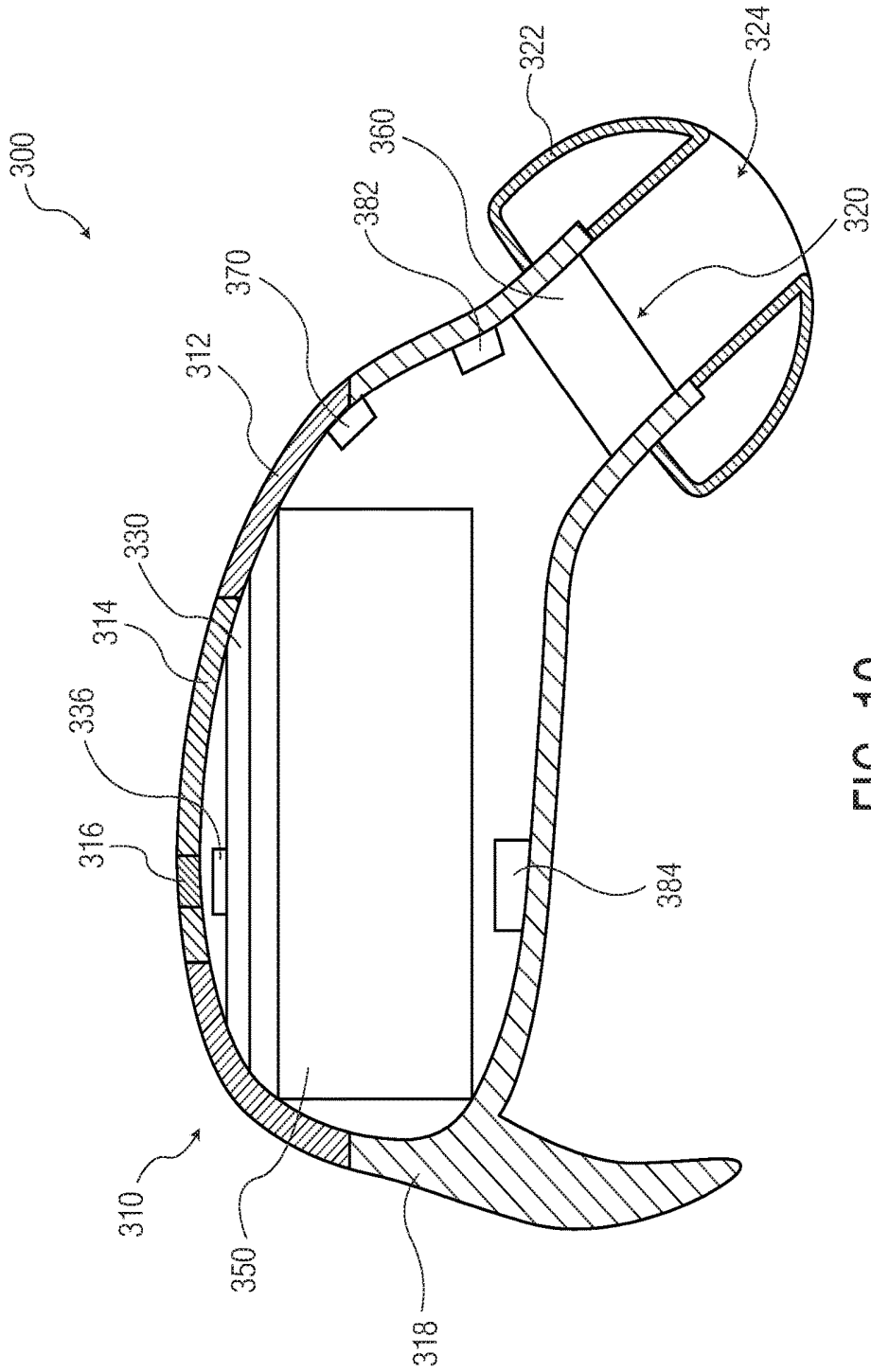

FIG. 19

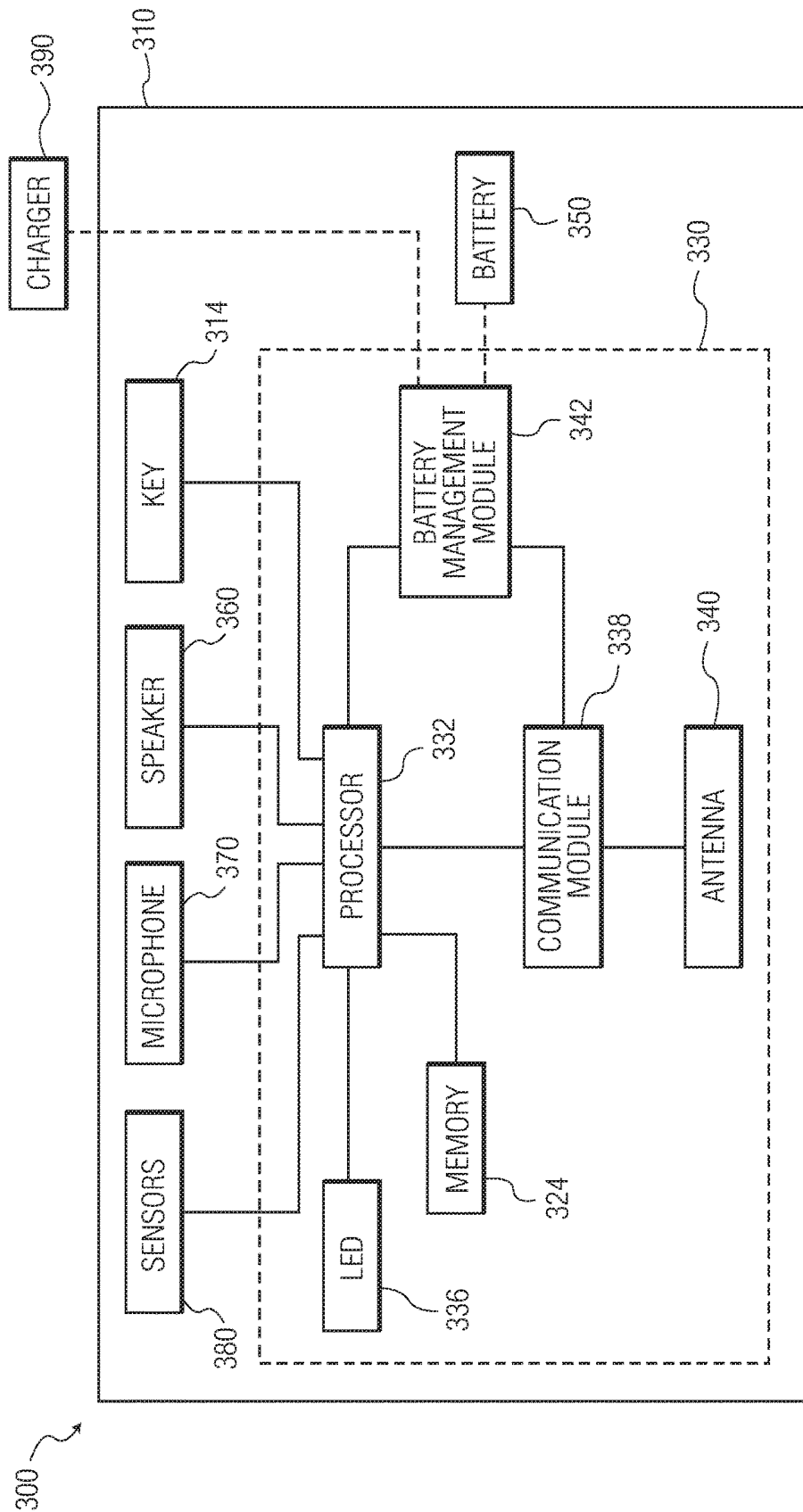

FIG. 20

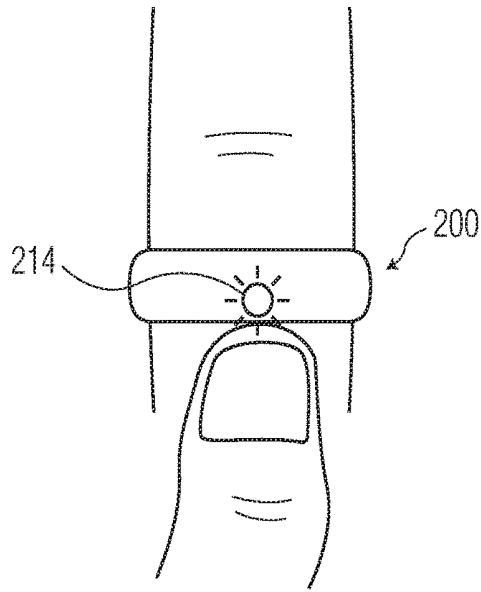

FIG. 21

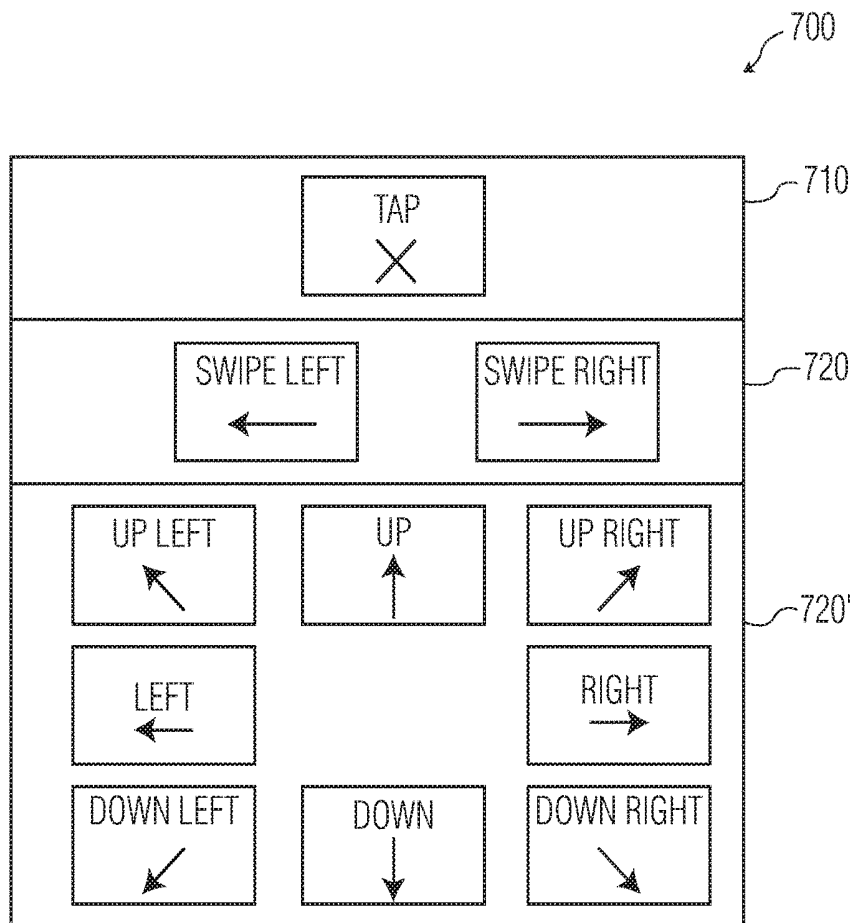

FIG. 22

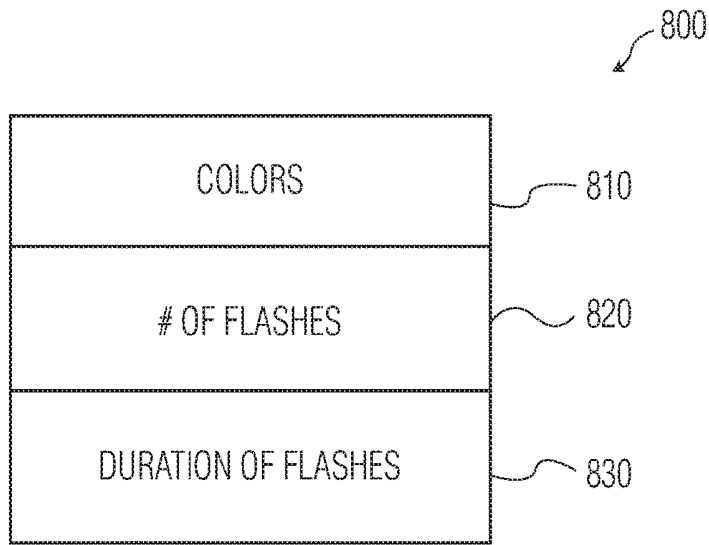

FIG. 23

700 GESTURES	900 ACTION	1000 STATE
GESTURE 1	VOLUME UP	PLAYING MUSIC
GESTURE 2	VOLUME DOWN	"
GESTURE 1	INITIATE PAIRING	PAIRING
GESTURE 2	END PAIRING	"
GESTURE 3	CONFIRMATION ON PAIRED DEVICE	"
• • •	• • •	• • •

FIG. 24

The table, labeled 244, is a two-column grid. The first column is labeled '800' and the second column is labeled '1100'. The table lists six notifications and their corresponding conditions, followed by three rows of vertical ellipses in both columns. A reference numeral '244' with a curved arrow points to the table.

800 NOTIFICATION	1100 CONDITION
NOTIFICATION 1	LOW BATTERY
NOTIFICATION 2	CHARGING
NOTIFICATION 3	FULLY CHARGED
NOTIFICATION 4	PHONE CALL
NOTIFICATION 5	IN PAIRING MODE
NOTIFICATION 6	PAIRED
•	•
•	•
•	•

FIG. 25

## WEARABLE ELECTRONIC DEVICE WITH INTERFACE

### CROSS-REFERENCE TO RELATED APPLICATIONS

This application is a continuation-in-part of U.S. patent application Ser. No. 14/179,097, filed on Feb. 12, 2014, which is a continuation-in-part of U.S. patent application Ser. No. 13/827,341, filed on Mar. 14, 2013, which claims the benefit of U.S. Provisional Patent Application No. 61/713,200, filed on Oct. 12, 2012.

### FIELD OF THE INVENTION

The present invention relates to a wearable electronic device, and more particularly, to a wearable electronic device having an interface for electronic communications.

### BACKGROUND

Mobile computing devices, such as mobile phones, are increasingly prevalent. As additional functions are developed for mobile computing devices, users spend more time using the devices. Known mobile computing devices, however, require a user to look at and interact with a screen in order to use the mobile computing device. Although mobile computing devices are useful in a wide range of applications, the increasing amount of time spent looking at the screen of mobile computing devices detracts from social encounters and also diminishes other interactions of the user with his environment. Mobile computing device users have a need to easily and intuitively utilize the benefits of the mobile computing device without spending large quantities of time looking at the screen.

### SUMMARY

An object of the invention, among others, is to provide a wearable electronic device which enables a user to interact with a mobile computing device without requiring looking at or interacting with the screen of the mobile computing device. The disclosed wearable electronic device comprises a ring body and a substrate. The ring body has an outer cover and an interface disposed on an exterior of the outer cover, with the ring body defining an annular receiving space within the ring body. The substrate is disposed in the annular receiving space and has a plurality of capacitive plates.

### BRIEF DESCRIPTION OF THE DRAWINGS

The invention will now be described by way of example with reference to the accompanying figures, of which:

FIG. 1 is a side view of a jewelry piece with an interchangeable radio frequency identification tag in accordance with some embodiments of the present disclosure;

FIG. 2 is a schematic exploded side view of a jewelry piece with an interchangeable radio frequency identification tag in accordance with some embodiments of the present disclosure;

FIG. 3 is a schematic top view, with components again exploded as in FIG. 2, of a jewelry piece with an interchangeable radio frequency identification tag in accordance with some embodiments of the present disclosure;

FIG. 4 is a schematic cross-section view of an example of the command module in accordance with some embodiments of the present disclosure;

FIG. 5 is a schematic cross-section view of an example of a jewelry piece with an interchangeable radio frequency identification tag in accordance with some embodiments of the present disclosure;

FIG. 6 is a schematic cross-section view of an example of a jewelry piece with an interchangeable radio frequency identification tag in accordance with some embodiments of the present disclosure;

FIG. 7 is a schematic cross-section view of an example of a jewelry piece with an interchangeable radio frequency identification tag in accordance with some embodiments of the present disclosure;

FIGS. 8A and 8B are schematic cross-sectional views of an example of a jewelry piece with an interchangeable radio frequency identification tag in accordance with some embodiments of the invention;

FIGS. 9A, 9B, 9C, and 9D are schematic cross-sectional views of an example of a jewelry piece with an interchangeable radio frequency identification tag in accordance with some embodiments of the invention;

FIG. 10 is perspective view of a wearable electronic device according to an embodiment of the invention;

FIG. 11 is an exploded view of the wearable electronic device of FIG. 10;

FIG. 12 is a schematic view of a substrate of the wearable electronic device of FIG. 10;

FIG. 13 is a schematic view of another substrate of the wearable electronic device of FIG. 10;

FIG. 14 is a block diagram of components of the substrate shown in FIG. 12;

FIG. 15 is an exploded view of the wearable electronic device of FIG. 10;

FIG. 16 is a sectional view of the wearable electronic device of FIG. 10;

FIG. 17 is a schematic view of a wireless communication system according to the invention;

FIG. 18 is a perspective view of an earbud of the wireless communication system of FIG. 17;

FIG. 19 is a sectional view of the earbud of FIG. 18;

FIG. 20 is a block diagram of the earbud of FIG. 18;

FIG. 21 is a schematic view of the wearable electronic device of FIG. 10 and a user;

FIG. 22 is a schematic view of gestures of the wearable electronic device of FIG. 10;

FIG. 23 is a schematic view of notifications of the wearable electronic device of FIG. 10;

FIG. 24 is a schematic view of the gestures of FIG. 22 along with actions and states; and

FIG. 25 is a schematic view of the notifications of FIG. 23 along with conditions.

### DETAILED DESCRIPTION OF THE EMBODIMENT(S)

This description of the exemplary embodiments is intended to be read in connection with the accompanying drawings, which are to be considered part of the entire written description. In the description, relative terms such as “lower,” “upper,” “horizontal,” “vertical,” “above,” “below,” “up,” “down,” “top” and “bottom” as well as derivative thereof (e.g., “horizontally,” “downwardly,” “upwardly,” etc.) should be construed to refer to the orientation as then described or as shown in the drawing under discussion. These relative terms are for convenience of description and do not require that the apparatus be constructed or operated in a particular orientation. Terms concerning attachments, coupling and the like, such as “con-

nected” and “interconnected,” refer to a relationship wherein structures are secured or attached to one another either directly or indirectly through intervening structures, as well as both movable or rigid attachments or relationships, unless expressly described otherwise.

In FIGS. 1 through 6, like items are indicated by like reference numerals and, for brevity, descriptions of a component or structure are not repeated. Materials describing the manufacture of a component in one description can be used to manufacture that component in each embodiment unless specifically stated otherwise.

The present disclosure provides an apparatus comprising a piece of jewelry connected with an interchangeable radio frequency identification (RFID) tag. The apparatus is provided to enable a user to conveniently and unobtrusively carry a RFID tag with a low probability of loss or damage to the tag.

In some embodiments, the jewelry piece is a ring. However, other jewelry pieces would be suitable for use in accordance with the present disclosure. Specifically, the present disclosure could be used to connect an interchangeable RFID tag with watches, pendants, brooches, earrings and other body piercing jewelry, necklaces, bracelets, amulets, medallions, hairpins, and any suitable jewelry pieces.

There are generally three types of RFID tags: active, passive, and battery-assisted passive. In some embodiments of the present disclosure uses a passive tag, which is generally cheaper and smaller than active or battery-assisted passive tags because it requires no independent power source. A passive tag uses the radio energy transmitted by a RFID reader as its power source. However, any type of RFID tag would be suitable for use with the present disclosure. Use of an active or battery-assisted passive RFID tag requires the addition of an independent power source such as a battery to the disclosed apparatus. The active RFID tags embodied in this disclosure are additionally capable of low- or reduced-power modes. In this disclosure, an RFID tag is not necessarily limited to any specific operating frequency. An RFID tag useable with the present invention may also operate with either regulated or unregulated frequencies.

FIG. 1 is a side view of one example of a jewelry piece 100 with an interchangeable RFID tag in accordance with some embodiments of the present disclosure. FIG. 1 shows the exterior of the apparatus with all component pieces assembled. Viewing the exterior, a user or viewer of the apparatus sees a cap 2, a housing 14, and a ring 16, which are described in further detail below.

FIG. 2 is a schematic exploded side view of an example of a jewelry piece 100 with an interchangeable RFID tag in accordance with some embodiments of the present disclosure. FIG. 2 illustrates how constituent pieces of the apparatus are fitted together in the illustrated embodiment.

Cap 2 is formed from a gemstone, a synthetic or imitation gemstone, or like material including glass or plastic. Cap 2 is often formed as a “cabochon” having a convex, substantially hemispherical surface and a flat surface. In the alternative, the cap can have a concave surface and a flat surface. The shape of cap 2 can vary, employing any suitable gemstone cutting techniques. Cap 2 is connected to housing 14 by cement, glue, solder, or other suitable adhesive.

Below cap 2 is a RFID tag 6 which may be of any suitable type and configuration but is illustrated as a RFID wafer. RFID tag 6 is disposed within a buffer ring 8. In some embodiments, buffer ring 8 is composed of a ferrite material. Buffer ring 8 is disposed within housing 14. RFID tag 6,

buffer ring 8, and the inner diameter of housing 14 are sized to minimize movement of the RFID tag 6 during use of the apparatus.

In some embodiments, the jewelry piece 100 includes one or both of a top spacer 4 and bottom spacer 10 to further minimize movement of RFID tag 6 during use. In some embodiments, top spacer 4 and bottom spacer 10 are composed of a material that does not substantially inhibit radio frequency transmission such as plastic or glass. A material does not substantially inhibit radio frequency transmission if the transmission range is not notably reduced by using that material. Materials that do not substantially inhibit radio frequency transmission, such as glass and plastic, are substantially permissive materials.

In some embodiments, top spacer 4 and bottom spacer 10 are composed of materials which inhibit radio frequency transmission, such as most metal alloys, as a way to limit the range of enclosed RFID tag 6. For example, if RFID tag 6 is readable from a distance of three feet from a jewelry piece 100 without top spacer 4 or bottom spacer 10, but if it is desired that RFID tag 6 only be readable at a distance of six inches from jewelry piece 100, then one or both of top spacer 4 and bottom spacer 10 may comprise a material which inhibits radio frequency transmission, which may be added to jewelry piece 100 to reduce the effective reading range of RFID tag 6. In some embodiments, the range of RFID tag 6 may be limited by the structure of RFID tag 6 or may be limited by programming. Also, spacers may not be necessary to limit the range but may be desired nonetheless to immobilize the contents of jewelry piece 100.

The unit formed by cap 2, RFID tag 6, buffer ring 8, and housing 14, when connected, is referred to as a command module 20. In some embodiments of the present disclosure, command module 20 is fully interchangeable, meaning a first command module connected to ring 16 can be removed and replaced with a second command module.

Housing 14 is formed from stainless steel, precious metal (gold, silver, platinum, and the like), or any suitable material for forming jewelry, such as carbon fiber or titanium alloys. Housing 14 is sized to fit within a receiving area 18 of ring 16. Housing 14 is connected to ring 16 by a screw post 12, which is a threaded member that is rotatably inserted into a threaded slot 22 in ring 16.

Ring 16 is formed from stainless steel, precious metal (gold, silver, platinum, and the like), or any suitable material for forming jewelry, such as carbon fiber or titanium alloys. In some embodiments, ring 16 may be formed from various insulating materials such as ceramic, nylon, acrylic, Lexan, Lucite, or the like, which provide non-radio wave interference properties, allow for low cost of production, low weight, improve esthetics, and can be easy to remove in an emergency.

In some embodiments, a ring formed from ceramic or similar material is given the appearance of a precious metal or other metal through chemical vapor deposition of a metal coating on the exterior surface of the ring. In other embodiments, a ring formed from ceramic or similar material is given the appearance of a precious metal or other metal through ionic beam subsurface deposition of metal below the exterior surface of the ring. Such embodiments have the advantage of appearing as metal rings while having minimal RF interference due to their ceramic construction.

Ring 16 includes a receiving area 18 and threaded slot 22 for receiving housing 14 and screw post 12, respectively. Housing 14 and ring 16 can be formed from the same material or different materials.

5

FIG. 3 is a schematic top view, with components again exploded as in FIG. 2, of a jewelry piece with an interchangeable radio frequency identification tag in accordance with some embodiments of the present disclosure. As in FIG. 2, FIG. 3 illustrates how the constituent components of jewelry piece 100 are fitted together. In the illustrated embodiment, RFID tag 6 is disposed within buffer ring 8, which in turn is disposed within housing 14 along with top spacer 4 and bottom spacer 10. Cap 2 is adhered to housing 14 to form command module 20. Command module 20 is operatively connected to ring 16 via a screw post 12 (not visible in FIG. 3) rotatably inserted into threaded slot 22.

Referring now to FIG. 4, in some embodiments, cap 40 comprises a top 42 connected to a threaded member 44 which can be rotatably inserted into a threaded recess 46 on ring 48. Top 42 is formed from a gemstone, a synthetic or imitation gemstone, or like material including glass or plastic. Top 42 is adhered or mounted to threaded member 44. A RFID tag 6 is disposed within a buffer ring 8, which is then disposed within threaded recess 46. Cap 40 seals RFID tag 6 and buffer ring 8 within the threaded recess 46 when rotatably inserted into the threaded recess 46. In some embodiments, one or more spacers can be included on either side of RFID tag 6 disposed within buffer ring 8. The one or more spacers can be either substantially permissive or substantially inhibiting, as described above.

In the embodiment shown in FIG. 4, ease of access to an enclosed RFID tag provides another means of interchangeability. In some embodiments, rather than changing out the entire command module 20, a user can unscrew cap 40 from ring 48 to remove cap 40, permitting access to and exchange of the enclosed RFID tag 6.

In some embodiments, shown in FIG. 5, the command module 20 is affixed to a modified ring 52 via a retaining clip 50. Retaining clip 50 is shaped to fit about the bottom of housing 14, and has a bulbous protrusion 56 on one side. Retaining clip 50 can also be a standard "C" clip. Once retaining clip 50 is connected to housing 14 using adhesive or simple friction, the entire command module 20 is slid into position, mounted on modified ring 52. The bulbous protrusion 56 is fitted into a groove 54 on modified ring 54, and command module 20 snaps into place on modified ring 52 where it is held by the union of bulbous protrusion 56 and groove 54. In some embodiments, one or more spacers can be disposed within command module 20, on either side of RFID tag 6 disposed within buffer ring 8. The one or more spacers can be either substantially permissive or substantially inhibiting, as described above.

In some embodiments, shown in FIG. 6, a hollow cap 60 is used to hold the RFID tag instead of the previously-described housing. As with previously-described cap 2, hollow cap 60 is formed from a gemstone, a synthetic or imitation gemstone, or like material including glass or plastic. Also, hollow cap 60 has a convex, substantially hemispherical surface and a flat surface. In the alternative, the cap can have a concave surface and a flat surface. Hollow cap 60 has a recess formed in the flat surface to hold an RFID tag 6 and buffer ring 8. In the illustrated embodiment, RFID tag 6 is disposed within buffer ring 8, which is then disposed within hollow cap 60. Hollow cap 60 is then affixed to a bezel setting 62 or similar plate, which has a screw post 66 that is rotatably insertable into a threaded slot 68 in ring 64. In some embodiments, one or more spacers can be

6

included on either side of RFID tag 6 disposed within buffer ring 8. The one or more spacers can be either substantially permissive or substantially inhibiting, as described above.

In some embodiments, shown in FIG. 7, a ring 72 has a channel 74 through its top portion. In some embodiments, the channel 74 is cylindrical and includes a notch 76 cut the full circumference of the channel 74. Channel 74 is sized to hold RFID tag 6 disposed within buffer ring 8. Notch 76 is sized to hold bottom retainer 78 in place. Bottom retainer 78 is formed from a flexible material, such as semi-rigid plastic, so it can be inserted and removed from notch 76. The diameter of bottom retainer 78 is larger than the diameter of channel 74 but smaller than the diameter of notch 76, allowing bottom retainer 78 to be held in place when inserted into notch 76. With bottom retainer 78 inserted into notch 76, buffer ring 8 and RFID tag 6 are disposed within channel 74 and sealed in place by cap 79.

Cap 79 may be connected to ring 72 by cement, glue, solder, or another adhesive.

As with cap 2, cap 79 is formed from a gemstone, a synthetic or imitation gemstone, or like material including glass or plastic. Also, cap 79 defines a convex, substantially hemispherical surface and a flat surface. In an alternative embodiment, cap 72 may define a concave surface and a flat surface.

In some embodiments, bottom retainer 78 is formed from a material that is substantially permissive of radio frequency transmission and cap 79 is formed from a material that substantially inhibits radio frequency transmissions. In this embodiment, the effective transmission range of RFID tag 6 is greatly limited.

In some embodiments, shown in FIGS. 8A and 8B, a jewelry piece 89 comprises an annular body 82 having a channel 74 with a protruding edge 83 that retains elements disposed within channel 74. When disposed within channel 74, cap 86 is prevented from exiting channel 74 by protruding edge 83. Cap 86, RFID tag 6, buffer ring 8, battery 84, and bottom retainer 78 are loaded from inner side 87 of channel 74 and retained on outer side 88 of channel 74 by protruding edge 83. In some embodiments, channel 74 may be cylindrical and include a notch 76 cut the full circumference of channel 74. Channel 74 may be sized to hold RFID tag 6 disposed within buffer ring 8. Notch 76 is sized to hold bottom retainer 78 in place. Bottom retainer 78 is formed from a flexible material, such as a semi-rigid polymer, so it can be inserted and removed from notch 76. The diameter of bottom retainer 78 is larger than the diameter of channel 74, but smaller than the diameter of notch 76, allowing bottom retainer 78 to be held in place when inserted into notch 76. With bottom retainer 78 inserted into notch 76, buffer ring 8 and RFID tag 6 are disposed within channel 74 and held in place by cap 86. As with cap 2, cap 86 may be formed from a gemstone, a synthetic or imitation gemstone, or like material including glass or plastic. Also, cap 86 may define a convex, substantially hemispherical surface and a flat surface. In alternative embodiments, cap 86 may define a concave surface and a flat surface. In some embodiments, bottom retainer 78 may be replaced with a retaining clip such as retainer clip 50 described above. In some embodiments, battery 84 is omitted and RFID tag 6 may comprise a passive-type tag. In other embodiments, spacers (not shown) are used to ensure RFID tag 6, buffer ring 8, and battery 84 remain immobilized during use. In

some embodiments, additional RFID tags are disposed within channel 74; multiple RFID strips are used to increase functionality or security of jewelry piece 89.

Referring to FIGS. 9A, 9B, 9C, and 9D, a ring 90 comprises two raised edges 92 defining a channel 94. A printed RFID strip 96 and decorative cover 104 are disposed within channel 94. In some embodiments, a battery 102 may also be disposed within the channel and operatively connected to RFID strip 96. Ring 90 is formed from stainless steel, precious metal (gold, silver, platinum, and the like), or other materials suitable for forming jewelry, e.g., carbon fiber or titanium alloys. In some embodiments, ring 90 may be formed from various insulating materials such as ceramic, nylon, acrylic, Lexan, or the like, which provide non-radio wave interference properties, allow for low cost of production, low weight, improve esthetics, and can be easy to remove in an emergency.

In some embodiments, a ring formed from ceramic or similar material is given the appearance of a precious metal or other metal through chemical vapor deposition of a metal coating on the exterior surface of the ring. In other embodiments, a ring formed from ceramic or similar material is given the appearance of a precious metal or other metal through ionic beam subsurface deposition of metal below the exterior surface of the ring. Such embodiments have the advantage of appearing as metal rings while having minimal RF interference due to their ceramic construction.

Ring 90 comprises an inner surface 106, an outer surface 108 defined by the top surfaces of raised edges 92, and a channel bottom surface 110. In some embodiments, ring 90 is annularly shaped. RFID strip 96 comprises a flexible substrate or semiconductor which includes at least one memory chip 98 and an antenna 100. In some embodiments, RFID strip 96 includes at least one RFID tag which may be of any suitable type and configuration such as a RFID wafer. In some embodiments, RFID strip 96 includes a printed, flexible CMOS integrated circuit. In some embodiments, battery 102 may be constructed from flexible materials, such as a flexible lithium or graphene battery. In some embodiments, additional RFID strips are disposed within channel 94; multiple RFID strips are used to increase functionality or security of ring 90.

Decorative cover 104 is dimensioned to fit into channel 94, and formed from a gemstone, a synthetic or imitation gemstone, or like material including glass or plastic. In some embodiments, decorative cover may be formed from a thermo-reactive material which changes color based on temperature. Decorative cover 104 may take many shape suitable for decorative and functional purposes. In some embodiments, decorative cover 104 may be connected to raised edges 92 by cement, glue, solder, or other suitable adhesive. In other embodiments, decorative cover 104 may be connected to raised edges 92 by friction fitting. In further embodiments, an exterior surface 112 of decorative cover 104 may be seated flush with outer surface 108 of ring 90. In yet further embodiments, decorative cover 104 may be formed over RFID strip 96 and battery 102. In many embodiments, decorative cover 104 is operatively connected to battery 102 and comprises solar power cells to charge the battery 102 with solar-generated electricity. In some embodiments, decorative cover 104 includes LED panels which are configured to display information to a user. For example, the panels may be configured to display messages regarding the status of the system, such as "00S" indicating the system is out of service or "Low Bat" indicating the battery power is about to run out of power. As another example, LED panels

may be configured to display various parameters to a user such as time, date, temperature, or user's pulse.

RFID strip 96 may be disposed on top of channel bottom surface 110, with battery 102 disposed above and operably connected to RFID strip 96. Decorative cover 104 is disposed above battery 102 and, in many embodiments without a battery 102, above RFID strip 96. In some embodiments, spacers (not shown) are used to ensure RFID strip 96 and/or battery 102 remain immobilized during use. Referring to FIG. 9D an assembled jewelry piece 91 includes an RFID strip 96 and battery 102 disposed between raised edges 92, channel bottom surface 110, and decorative cover 104. Exterior surface 112 of decorative cover 104 sits flush with outer surface 108 of ring 90.

In some embodiments, a plurality of nanocapacitors may be applied to the surface of or integrated with the material forming ring 90. In some embodiments, the nanocapacitors are graphene nanocapacitors. In some embodiments, the nanocapacitors are formed as disclosed in U.S. Patent Application Publication 2013/0224394, the entirety of which is herein incorporated by reference. The nanocapacitors are configured to absorb ambient energy, such as solar energy or thermal energy from the user, and convert it to electrical energy to be used by RFID strip 96.

In each of the embodiments presented above a sealant may be used between components to create a sealed chamber containing the RFID tag. For example, in the jewelry piece 100 presented in FIG. 1, a sealant may be used between cap 2 and housing 14. As another example, a sealant may be used between the decorative cover 104 and ring 90 of jewelry piece 91 presented in FIGS. 9A, 9B, 9C, and 9D. In some embodiments, the sealant may be silicon-based, in other embodiments the sealant may be an epoxy sealer.

In some embodiments of the present disclosure, a portion or all of the exterior surface of the jewelry piece is finished with a scratch resistant coating such as certain ceramics, diamond chemical vapor deposition, or the like. Further, in some embodiments, each component disclosed above which includes at least one exterior surface of the jewelry piece is formed from ceramic, glass, gemstone, carbon fiber composite, solar cell, LED screen, diamond chemical vapor deposition, or any combination thereof.

The use of RFID tags has spread to innumerable applications, and embodiments of the present disclosure can be applied in numerous ways. In general use, a RFID tag is read by an RFID reader to transfer data on the tag to the reader. The RFID reader is operatively connected to a computer or other processing system and transfers data from the tag to the computer or processing system for use.

By way of example, RFID tags can be used in a key fob to provide keyless locking and unlocking of a vehicle door. The RFID tag enclosed in the fob uniquely identifies the key associated with a given vehicle. As a driver approaches the vehicle door, a RFID reader located in the door handle, door, or elsewhere in the vehicle reads the identifying information contained on the RFID tag. A processing system uses this identifying information to determine if the key fob is associated with the vehicle and should thus be granted access to the vehicle. If the key fob is positively associated with the vehicle, the processing system sends a signal to the vehicle door to unlock.

Additional uses of the present disclosure are included in Table 1. Table 1 assumes the implementation device (i.e.—vehicle) is equipped with a RFID reader and associated circuitry. The examples in Table 1 are provided for illustrative purposes and are in no way meant to be a full list of potential applications of the present disclosure.

TABLE 1

Applications of the Present Disclosure
Keyless starting of a vehicle
Arming or disarming a security system
Opening, locking, or unlocking a residential or commercial door, gate, or equivalent
Opening, locking, or unlocking a safe
Enabling operation of a firearm
Payment using credit or debit card information loaded into RFID tag
Opening, locking, unlocking, or starting a personal watercraft, motorcycle, or machinery
Enabling use of a cellular telephone
Verifying identity at an airport or security checkpoint
Verifying identity, license, insurance status, and vehicle registration during a traffic stop

The jewelry piece with interchangeable RFID tag disclosed above has several advantages. A jewelry piece provides a convenient and unobtrusive way to carry an RFID tag and is less likely than a badge, key fob, or other RFID tag carrier to be lost or damaged. By making the RFID tag interchangeable through the various means disclosed above, the jewelry piece provides a flexibility to the user to carry with them a range of information. For example, a user can have a jewelry piece with a command module containing an RFID tag loaded with identifying information specific to their professional life, i.e. containing login information for their work computer, access information to their office, etc. That same user could then switch command modules, outfitting the jewelry piece with a second command module loaded with personal information such as identifying information for specific use at a doctor's office. In various circumstances, a user could chose to limit the data they carry within their jewelry piece so as to limit the potential for fraud and identity or information theft. Command modules could also be exchanged for purely aesthetic purposes.

As yet another advantage of the invention, the jewelry piece with interchangeable RFID tag may be an entirely covert means of carrying information. As will be known to those skilled in the art, RFID transceivers and their associated circuitry are capable of securely storing a substantial amount of information. As disclosed above, this circuitry may also monitor and provide real-time information such as time, date, temperature, or user's pulse. The information contained in the RFID tag may be carried within the jewelry piece and is thus be concealed from public view.

In some embodiments, an apparatus for conveniently carrying a radio frequency identification tag comprises a jewelry piece including a threaded slot for receiving a screw post; a cap with a convex, substantially hemispherical surface and a flat surface, the flat surface connected to a housing including the screw post; a radio frequency identification tag, disposed within a buffer ring which is disposed within the housing; and wherein the housing is operatively connected to the jewelry piece by rotatably inserting the screw post in the threaded slot.

In some embodiments, an apparatus for carrying a radio frequency identification tag within a jewelry ring comprises a jewelry ring including a threaded slot; a bezel setting comprising a flat plate and a screw post, wherein the bezel setting is operatively connected to the jewelry ring by rotatably inserting the screw post into the threaded slot; a cap comprising a convex, substantially hemispherical surface and a flat surface including a recess, and wherein the flat surface is connected to the bezel setting; and a radio frequency identification tag, disposed within a buffer ring which is disposed within the recess of said cap.

In some embodiments, an apparatus for carrying a radio frequency identification tag within a jewelry ring comprises a jewelry ring including a threaded recess; a cap comprising a substantially hemispherical portion and a threaded member portion; and a radio frequency identification tag, disposed within a buffer ring, the buffer ring disposed within the threaded recess wherein the threaded recess encloses the radio frequency identification tag and the buffer ring when the cap is rotatably inserted into the threaded recess.

A wearable electronic device **200** according to another embodiment of the invention is shown in FIGS. **10-17** and **21**. The wearable electronic device **200** has a ring body **210**, a substrate **240**, a battery **270**, an inductive layer **280**, and a shielding layer **290**. The major components of the wearable electronic device **200** will now be described in greater detail.

The ring body **210** is shown in FIGS. **10**, **12**, and **13**, and includes an outer cover **212**, an interface **214**, a first side cover **216**, a second side cover **217**, and a sizing insert **218**.

The outer cover **212**, as shown in FIGS. **10**, **11**, and **15** is an annular member. The outer cover **212** may be formed from glass, a plastic material such as acrylic glass, a gemstone, a synthetic or imitation gemstone, or a ceramic material. In some embodiments, the material of the outer cover **212** includes a plurality of nanocapacitors **213** applied to the surface of or integrated with the material forming the outer cover **212**. The nanocapacitors **213** may be graphene nanocapacitors. The nanocapacitors **213** are configured to absorb ambient energy, such as solar energy or thermal energy from the user, and convert it to electrical energy. The interface **214** is disposed on an exterior of the outer cover **212** and may be located toward one side of the outer cover **212**, as shown in FIGS. **10** and **11**.

As shown in FIG. **10**, the interface **214** has a raised portion **214a** protruding from the exterior of the outer cover **212** to an interface surface **214b**. In the shown embodiment, the interface surface **214b** is circular and the raised portion **214a** is consequently cylindrical. One with ordinary skill in the art would appreciate that the interface surface **214b** may alternatively have a variety of shapes, including a square or a rectangle. The interface **214** may be formed from a plastic, glass, or metal material.

The first side cover **216** and the second side cover **217**, as shown in FIGS. **10** and **11**, are annular members formed from a plastic material. In the shown embodiment, the first side cover **216** and the second side cover **217** are identically shaped.

The sizing insert **218**, as shown in FIGS. **10** and **11**, is an annular member which may be formed from a metal, a plastic, or may be a plastic filled with carbon. In the shown embodiment, the sizing insert **218** has a plurality of insert passageways **219** extending through the sizing insert **218**.

The substrate **240** is shown in FIGS. **11-14**. In the shown embodiment, the substrate **240** is a flexible printed circuit board. As would be appreciated by one with ordinary skill in the art, the substrate **240** may alternatively be a shaped, rigid printed circuit board. The substrate **240** has disposed thereon a processor **242**, a memory **244**, a plurality of capacitive plates **246**, a light emitting diode (LED) **248**, an accelerometer **250**, a communication module **252**, an antenna **254**, and a battery management module **256**.

The processor **242** may be any form of processor known to those with ordinary skill in the art. The memory **244** is connected to the processor **242** and is a non-transitory computer readable medium storing software instructions executable by the processor **242**.

The plurality of capacitive plates **246** are flat members disposed on the substrate **240** which store electrical energy.

The plurality of capacitive plates **246** are each connected to the processor **242**, and each send a signal to the processor **242** indicating a change in a stored capacitance value.

The LED **248** may be any form of LED known to those with ordinary skill in the art, such as an RGB LED. The LED **248** is connected to the processor **242** and controlled by the processor **242** to illuminate in a range of colors with various frequencies and various durations.

As shown in FIG. **12**, the plurality of capacitive plates **246** may be arranged linearly and equidistant from one another along the substrate **240**, with the LED **248** disposed centrally among the plurality of capacitive plates **246**. In an alternative embodiment of a substrate **240'** shown in FIG. **13**, the plurality of capacitive plates **246'** may be arranged equidistant from one another and encircling the LED **248**.

The accelerometer **250**, in the shown embodiment, is a three-axis micro electro-mechanical system (MEMS) accelerometer, but as would be appreciated by one with ordinary skill in the art, may be a single-axis or two-axis accelerometer. The accelerometer **250** is connected to the processor **242** and sends a signal to the processor **242** indicating acceleration along each of axes of the accelerometer **250**.

The communication module **252** is a device capable of wirelessly communicating data over short distances. The communication module **252** may, for instance, be a device communicating using short-wavelength radio waves, such as a Bluetooth device. In the shown embodiment, the communication module **252** is a Bluetooth low energy device having a communication range of at least ten meters. The communication module **252** is connected to the processor **242** and the antenna **254**, and transmits and receives data externally of the wearable electronic device **200** via the antenna **254**. The antenna **254** may be any form of antenna **254** known to those with ordinary skill in the art, and may be printed on the substrate **240**. The antenna **254** may be formed of a conductive material, such as copper, gold, graphene, or other antenna materials known to those with ordinary skill in the art.

The battery management module **256** is connected to the processor **242** and the communication module **254**. The battery management module **256** receives power and distributes power to the processor **242** and the communication module **252** within the substrate **240**.

The battery **270** is shown in FIGS. **11**, **14**, **15**, and **16**. In the shown embodiment, the battery **270** is a flexible lithium-ion battery. The battery **270** may alternatively be rigid, and/or may be an aluminum-ion battery, an alkaline battery, or other type of battery known to those with ordinary skill in the art.

The inductive layer **280** and the shielding layer **290** disposed on the sizing insert **218** are shown in FIGS. **11** and **16**. The inductive layer **280** is formed of a material capable of receiving an inductive charge, such as copper, aluminum, graphene, or other materials capable of receiving an inductive charge known to those with ordinary skill in the art. In the shown embodiment, the inductive layer **280** is formed as a coil disposed on the sizing insert **218**, but the inductive layer **280** could alternatively be printed on the sizing insert **218**. The shielding layer **290** comprises a magnetic shielding material, such as a metal material.

The assembly of the wearable electronic device **200** will now be described in greater detail with reference to FIGS. **11-16**.

The battery **270** is electrically connected to the substrate **240** at the battery management module **256**, as shown in FIGS. **11** and **14**, and provides power to the substrate **240**. The connected battery **270** and substrate **240** are bent or

otherwise positioned within the outer cover **212**, as shown in FIG. **15**. The substrate **240** is positioned within the outer cover **212** such that, as shown in FIGS. **12** and **13**, the interface **214** is aligned with the LED **248** and is positioned proximate the plurality of capacitive plates **246**, aligned with a center of the plurality of capacitive plates **246**. The interface **214** may overlap a portion of the plurality of capacitive plates **246**.

As shown in FIGS. **11** and **16**, the inductive layer **280** is disposed circumferentially around an exterior of the sizing insert **218**, and the shielding layer **290** is disposed circumferentially around the inductive layer **280**. The sizing insert **218** having the inductive layer **280** and the shielding layer **290** disposed thereon is positioned within the battery **270** and substrate **240**, as shown in FIG. **15**.

The first side cover **216** and the second side cover **217** are attached to opposite ends of the outer cover **212** and the sizing insert **218**, as shown in FIGS. **10**, **11**, and **16**, using an adhesive, such as a silicone adhesive, an epoxy, or other adhesives known to those with ordinary skill in the art. An exterior edge of the first side cover **216** is attached to a first end of the outer cover **212**, and an interior edge of the first side cover **216** is attached to a first end of the sizing insert **218**. An exterior edge of the second side cover **217** is attached to an opposite second end of the outer cover **212**, and an interior edge of the second side cover **217** is attached to an opposite second end of the sizing insert **218**. The assembly of the ring body **210** including the outer cover **212**, the sizing insert **218**, the first side cover **216**, and the second side cover **217** thus defines an annular receiving space **220** within the ring body **210** in which the substrate **240**, battery **270**, inductive layer **280**, and shielding layer **290** are disposed.

The wearable electronic device **200** is charged by a charger **258** shown in FIG. **14**. The charger **258** forms an electrical connection with the battery management module **256** and transfers power to the battery management module **256**. The battery management module **256** transmits the received power to charge the battery **270**, and also distributes power from the battery **270** and charger **258** to the processor **242** and communication module **252**. The charger **258** may be a contact charger, with portions of the charger **258** mating with the plurality of insert passageways **219** to contact the battery management module **256**. The charger **258** may alternatively be an inductive charger, in which case the charger **258** is inductively coupled to the battery management module **256** via the inductive layer **280** in order to transfer power.

The wearable electronic device **200** is used within a wireless communication system **400** which, as shown in FIG. **17**, may also include a plurality of earbuds **300**, a mobile computing device **500**, and another device **600**.

One of the plurality of earbuds **300** is shown in FIGS. **17-20**. The earbud **300** has a housing **310**, a substrate **330**, a battery **350**, a speaker **360**, a microphone **370**, and a plurality of sensors **380**. The major components of the earbud **300** will now be described in greater detail.

The housing **310** is shown in FIGS. **18** and **19**. The housing **310** has an upper cover **312**, a lower cover **318**, and a dome portion **322**.

The upper cover **312**, as shown in FIGS. **18** and **19**, has a key **314** disposed approximately centrally within the upper cover **312**. The key **314** is movable with respect to the rest of the upper cover **312**, such as by depression from a user. The key **314** has an indicator **316**. In the shown embodiment, the indicator **316** is a transparent circular portion disposed biased from a center of the key **314**. As would be appreciated

by those with ordinary skill in the art, the indicator **316** may alternatively be translucent, and may be a square, rectangle, or any other shape known to those with ordinary skill in the art. The upper cover **312** is formed of a plastic material.

The lower cover **318**, as shown in FIGS. **18** and **19**, is formed to be removably positioned in a user's ear. The lower cover **318** is formed of a plastic material, and has a lower cover passageway **320** formed at one end.

The dome portion **322** is shaped to fit in a user's ear canal and has a dome passageway **324** formed at one end. The dome portion **322** is formed of a plastic material.

The substrate **330** is shown in FIGS. **19** and **20**. In the shown embodiment, the substrate **330** is a flexible printed circuit board. As would be appreciated by one with ordinary skill in the art, the substrate **330** may alternatively be a shaped, rigid printed circuit board. The substrate **330** has disposed thereon a processor **332**, a memory **334**, a light emitting diode (LED) **336**, a communication module **338**, an antenna **340**, and a battery management module **342**.

The processor **332** may be any form of processor known to those with ordinary skill in the art. The memory **334** is connected to the processor **332** and is a non-transitory computer readable medium storing software instructions executable by the processor **332**.

The LED **336** may be any form of LED known to those with ordinary skill in the art, such as an RGB LED. The LED **336** is connected to the processor **332** and controlled by the processor **332** to illuminate in a range of colors with various frequencies and various durations.

The communication module **338** is a device capable of wirelessly communicating data over short distances. The communication module **338** may, for instance, be a device communicating using short-wavelength radio waves, such as a Bluetooth device. In the shown embodiment, the communication module **338** is a Bluetooth low energy device having a communication range of at least ten meters. The communication module **338** is connected to the processor **332** and the antenna **340**, and transmits and receives data externally of the earbud **300** via the antenna **340**. The antenna **340** may be any form of antenna **340** known to those with ordinary skill in the art, and may be printed on the substrate **310**. The antenna **340** may be formed of a conductive material, such as copper, gold, graphene, or other antenna materials known to those with ordinary skill in the art.

The battery management module **342** is connected to the processor **332** and the communication module **338**. The battery management module **342** receives power and distributes power to the processor **332** and the communication module **338** within the substrate **330**.

The battery **350** is shown in FIGS. **19** and **20**. In the shown embodiment, the battery **350** is a flexible lithium-ion battery. The battery **350** may alternatively be rigid, and/or may be an aluminum-ion battery, an alkaline battery, or any other type of battery known to those with ordinary skill in the art. The battery **350** is electrically connected to the substrate **310** at the battery management module **342**, as shown in FIG. **20**, and provides power to the substrate **310**.

The speaker **360** is shown in FIGS. **19** and **20**. The speaker **360** may be any type of audio speaker known to those with ordinary skill in the art. The speaker **360** is connected to the processor **332** and outputs audio based on signals received from the processor **332**.

The microphone **370** is shown in FIGS. **19** and **20**. The microphone **370** may be any type of microphone known to those with ordinary skill in the art. The microphone **370** is

connected to the processor **332** and transmits signals to the processor **332** based on audio received at the microphone **370**.

The plurality of sensors **380** are shown in FIGS. **19** and **20** and may include a heartrate sensor **382** and a body temperature sensor **384**. The heartrate sensor **382** detects a heartrate of a user and transmits signals to the processor **332** indicative of the user's heartrate. The body temperature sensor **384** detects a body temperature of a user and transmits signals to the processor **332** indicative of the user's body temperature.

The assembly of the earbud **300** will now be described in greater detail with reference to FIGS. **18** and **19**. The substrate **330** is fixed to the upper cover **312** and is positioned such that the LED **336** is aligned with the indicator **316**. The substrate **330** is also connected to the key **314** such that movement of the key **314** transmits a signal to the processor **332**. As shown in FIG. **19**, the battery **350**, speaker **360**, microphone **370**, and plurality of sensors **380** are disposed within the housing **310**, and the lower cover **318** is attached to the upper cover **312**. The dome portion **322** is disposed on the lower cover **318** and the dome passageway **324** aligns with the lower cover passageway **320**.

The earbud **300** is charged by a charger **390** shown in FIG. **20**. The charger **390** forms an electrical connection with the battery management module **342** and transfers power to the battery management module **342**. The battery management module **342** transmits the received power to charge the battery **350**, and also distributes power from the battery **350** and charger **390** to the processor **332** and communication module **338**. The charger **390** may be a contact charger, with portions of the charger **390** contacting the battery management module **342** to electrically connect with the battery management module **342**. The charger **390** may alternatively be an inductive charger, in which case the charger **390** is inductively coupled to the battery management module **342** by an electromagnetic field in order to transfer power.

Mobile computing device **500** shown in FIG. **17** may be any known mobile device executing applications and capable of wireless communication, such as a mobile phone, a tablet computer, or any other mobile devices known to those with ordinary skill in the art.

Other device **600** shown in FIG. **17** may be any other known device capable of wireless communication, such as computers, vehicles, household items, and point of sale (POS) systems.

The use of the wearable electronic device **200** within the wireless communication system **400** will now be described in greater detail with reference to FIGS. **17** and **21-25**.

The wearable electronic device **200** is shown positioned on a user's finger in FIG. **21**. The wearable electronic device **200** is shown positioned such that a user's thumb can access the interface **214**, but the wearable electronic device **200** could be positioned on any finger and accessed by any other finger.

The user inputs gestures **700** shown in FIG. **22** to the wearable electronic device **200**, which can be transmitted throughout the wireless communication system **400**. To input a gesture **700**, the user moves a finger in various directions relative to the interface **214**. As the user's finger moves over the interface **214**, the user's finger is also moving relative to the plurality of capacitive plates **246** positioned within the outer cover **212** around the interface **214**. As the user's finger is positioned over or moves with respect to each of the plurality of capacitive plates **246**, a stored electrical energy in each capacitive plate of the plurality of capacitive plates **246** changes dependent on the

relative position and movement of the user's finger. Each of the plurality of capacitive plates 246 sends a signal indicating a change in the stored electrical energy to the processor 242. The processor 242, executing software stored on the memory 244, compares the relative changes in stored electrical energy of each of the plurality of capacitive plates 246, and based on this information, determines the position and movement of the user's finger corresponding to a gesture 700. The plurality of capacitive plates 246 thus act as a capacitive touch sensor on the wearable electronic device 200.

The gestures 700 shown in FIG. 22 include tap gestures 710 and swipe gestures 720, 720'.

For the tap gestures 710, the user moves his finger only in a vertical direction and touches the interface 214. Variations in the duration of the tap and the number of consecutive taps determine the range of possible tap gestures 710. The tap gestures 710 are the same for both the substrate 240 shown in FIG. 12 and the substrate 240' shown in FIG. 13.

For the swipe gestures 720, 720', the user moves his finger horizontally over the interface 214 in various directions. First swipe gestures 720 are associated with the substrate 240 shown in FIG. 12. In the substrate 240, the plurality of capacitive plates 246 are arranged linearly, and the user can input a swipe left or a swipe right gesture over the interface 214. The number of consecutive swipes and combinations of left and right swipe directions determine the range of possible first swipe gestures 720. Second swipe gestures 720' are associated with the substrate 240' shown in FIG. 13. In the substrate 240', the plurality of capacitive plates 246' are arranged in a circular pattern, and the user can input a swipe left, a swipe right, a swipe up, a swipe down, a swipe diagonal up-left, a swipe diagonal up-right, a swipe diagonal down-right, and a swipe diagonal down-left over the interface 214. The number of consecutive swipes and combinations of swipe directions determine the range of possible second swipe gestures 720'.

Once the processor 242 determines which gesture 700 the user has input, the processor 242 compares the gesture 700 to a list of user-definable actions 900 for each state 1000 of the wearable electronic device 200, as shown in FIG. 24. The list of user-definable actions 900 correlated with states 1000 of the wearable electronic device 200 and gestures 700 is stored in the memory 244. The processor 242 retrieves the corresponding user-definable action 900, and controls the relevant component to execute the user-definable action 900 associated with the gesture 700 and state 1000. Exemplary user-definable actions 900 and states 1000 of the wearable electronic device 200 associated with gestures 700 will be described in greater detail below.

The wearable electronic device 200 receives notifications 800 shown in FIG. 23 from the wireless communication system 400. The notifications 800 occur at the LED 248 aligned with the interface 214. The notifications 800 can vary in color 810, number of illuminated flashes 820, and duration of each illuminated flash 830. Combinations of colors 810, number of flashes 820, and duration of flashes 830 determine the range of possible notifications 800. The notification 800 light emitted by the LED 248 illuminates at least a portion of the outer cover 212 surrounding the interface 214.

Based on signals received from the wireless communication system 400, described in greater detail below, the processor 242 compares a condition 1100 dictated by the received signals to a list of notifications 800 correlated to conditions 1100 stored in the memory 244 and shown in FIG. 25. The processor 242 retrieves the notification 800

correlated to the condition 1100 and controls the LED 248 to emit the correlated notification 800.

The use of the gestures 700 and notifications 800 within the wireless communication system 400 will now be described in greater detail with reference to FIGS. 17 and 21-25.

A set of notifications 800 can be associated with a state of charge condition 1100 of a state of charge of the battery 270 of the wearable electronic device 200. Notifications 800 may, for example, illuminate the LED 248 to flash 820, 830 a red color 810 when the processor 242 has received a signal indicating that the battery 270 has a low charge, may illuminate the LED 248 a solid red color 810 when the wearable electronic device 200 is connected to the charger 258, and may illuminate the LED 248 a solid white color 810 when the battery 270 is fully charged.

The wearable electronic device 200 is wirelessly connected with the mobile computing device 500 and the plurality of earbuds 300. The wearable electronic device 200 is paired with each of the mobile computing device 500 and one of the plurality of earbuds 300 to initiate the wireless connection.

A set of gestures 700 can be associated with pairing actions 900 for a pairing state 1000. A user inputs a gesture 700 at the interface 214 to initiate wireless pairing, for example, by inputting a single tap 710 of a predetermined duration. Once available for pairing, the communication module 252 of the wearable electronic device 200 connects with the communication module 338 of the earbud 300 and a similar communication module in the mobile computing device 500. The communication module 338 of the earbud 300 and the communication module of the mobile computing device 500 are also connected. The user may input another gesture 700 to initiate a pairing confirmation on a paired device, and may input a further gesture 700 to terminate the wireless pairing, for example, by inputting a single tap 710 of a predetermined duration.

A set of notifications 800 can also be associated with pairing conditions 1100 of the wearable electronic device 200, the earbud 300, and the mobile computing device 500. A notification 800 can indicate that pairing has been initiated, and another notification 800 can indicate that pairing has been completed.

Once connected, the wearable electronic device 200, the earbud 300, and the mobile computing device 500 can wirelessly exchange data via the communication modules 252, 338. The earbud 300 can, for example, transmit data from the plurality of sensors 380 to the mobile computing device 500 via the communication module 338. The wearable electronic device 200 can transmit accelerometer 250 data to the mobile computing device 500 via the communication module 252.

A set of notifications 800 can be associated with correspondence conditions 1100 received at the mobile computing device 500. For example, when the mobile computing device 500 receives an incoming call, the mobile computing device sends a signal to the wearable electronic device 200, which is received by the communication module 252 and sent to the processor 242. The processor 242 compares the received call data to the list shown in FIG. 25 stored in the memory 244, and executes the notification 800 associated with the received call data, for example, by controlling the LED 248 to flash 820, 830 a white color 810. Another notification 800 can be associated with received email correspondence, and a further notification 800 can be associated with received text correspondence.

A further set of notifications **800** can also be associated with known application conditions **1100** executed on the mobile computing device **500**. For example, a separate notification **800** can be associated with each of a calendar application alert, a TWITTER alert, an INSTAGRAM alert, and a FACEBOOK alert, among conditions **1100** of other applications known to those with ordinary skill in the art.

Gestures **700** input to the wearable electronic device **200** are determined by the processor **242** and compared to the list of actions **900** and states **1000** shown in FIG. **24**. When the action **900** involves either the mobile computing device **500** or the earbuds **300**, the processor **242** sends a signal indicating the action **900** to the earbuds **300** and the mobile computing device **500** via the communication module **252**. The processor **332** of the earbud **300** and a processor of the mobile computing device **500** receive the signal and control the corresponding components to execute the action **900**.

A set of gestures **700** can be associated with notification actions **900** in a notification state **1000**. A gesture **700** can be used to toggle notifications **800** on and off, and another gesture **700** can be used to recall previous notifications **800**; each of these gestures **700** is determined by the processor **242** and used directly to control the LED **248**.

A set of gestures **700** can be associated with phone call actions **900** on the mobile computing device **500** in a phone call state **1000**. When a call is incoming, a gesture **700** can be used to reject the call, and another gesture **700** can be used to answer the call. If the call is answered, the audio received at the mobile computing device **500** may be transmitted to the earbuds **300** and played via the speakers **360**. The microphone **370** receives audio and transmits the audio back to the mobile computing device **500**. During the call, a gesture **700** can be used to increase the volume of the speakers **360**, another gesture **700** can be used to decrease the volume of the speakers **360**, a further gesture **700** can be used to end the phone call, and an additional gesture **700** can be used to toggle the audio between the earbud **300** and the mobile computing device **500**.

A set of gestures **700** can be associated with text message actions **900** on the mobile computing device **500** in a text message state **1000**. A gesture **700** can be used to initiate a text message, various gestures **700** can be used to input text into the text message, and a gesture **700** can be used to send the text message.

A set of gestures **700** can be associated with email actions **900** on the mobile computing device **500** in an email state **1000**. A gesture **700** can be used to initiate an email message, various gestures **700** can be used to input text into the email message, and a gesture **700** can be used to send the email message.

A set of gestures **700** can be associated music output actions **900** on either the mobile computing device **500** or the earbuds **300** in a music output state **1000**. A gesture **700** can be used to play and pause the music, another gesture **700** can be used to increase the volume, another gesture **700** can be used to decrease the volume, another gesture **700** can be used to skip to the next song, and another gesture **700** can be used to skip to the previous song.

A set of gestures **700** can be associated with music input actions **900** on either the mobile computing device **500** or the earbuds **300** in a music input state **100**. A plurality of gestures **700** could individually correspond to musical notes output at the mobile computing device **500** or the earbuds **300**.

The lists of gestures **700** and notifications **800** described above and shown in FIGS. **24** and **25** are merely exemplary. One with ordinary skill in the art would understand that

many other applications and combinations of gestures **700** and notifications **800** are possible.

The wearable electronic device **200** can also communicate other information stored in the memory **242** to external devices.

The wearable electronic device **200** can automatically communicate identification information stored in the memory **242** to external devices. For example, a passcode for the mobile computing device **500** may be stored in the memory **242**, and when the communication module **252** is within a communication range of the mobile computing device **500**, the processor **242** automatically executes software stored in the memory **242** to transmit the passcode to the mobile computing device **500** via the communication module **252**. Whenever the user of the wearable electronic device **200** is within a communication range of his mobile computing device **500**, the mobile computing device **500** receives the passcode, compares the passcode to a stored passcode, and automatically unlocks if the passcodes match. The wearable electronic device **200** could similarly unlock other devices **600** shown in FIG. **17** such as computers, vehicles, and household items.

The wearable electronic device **200** can also communicate payment information to external devices. For example, when the communication module **252** is within communication range of a point of sale (POS) system **600**, the user can input a gesture **700** to make payment.

What is claimed is:

1. A wearable electronic device, comprising:

a ring body having an outer cover, a first side cover, a second side cover, a sizing insert, and an interface disposed on an exterior of the outer cover, the outer cover, first side cover, second side cover, and sizing insert defining an annular receiving space within the ring body;

a substrate disposed in the annular receiving space and having a plurality of capacitive plates, the interface positioned proximate the plurality of capacitive plates; and

an inductive layer disposed in the annular receiving space around the sizing insert.

2. The wearable electronic device of claim 1, wherein the interface is aligned with a center of the plurality of capacitive plates.

3. The wearable electronic device of claim 1, wherein the interface is positioned toward one side of the exterior of the outer cover.

4. The wearable electronic device of claim 3, wherein the interface comprises a raised portion protruding from the exterior of the outer cover to an interface surface.

5. The wearable electronic device of claim 1, wherein the plurality of capacitive plates are arranged linearly along the substrate.

6. The wearable electronic device of claim 1, further comprising a light emitting diode disposed on the substrate and aligned with the interface.

7. The wearable electronic device of claim 6, wherein the plurality of capacitive plates are arranged encircling the light emitting diode on the substrate.

8. The wearable electronic device of claim 1, wherein the substrate is a flexible printed circuit board.

9. The wearable electronic device of claim 1, further comprising a short-wavelength radio wave communication module disposed on the substrate.

10. The wearable electronic device of claim 1, further comprising a battery disposed in the annular receiving space and connected to the substrate.

11. The wearable electronic device of claim 1, further comprising an accelerometer disposed on the substrate.

12. The wearable electronic device of claim 1, further comprising a shielding layer disposed in the annular receiving space around the inductive layer.

13. The wearable electronic device of claim 1, wherein the outer cover has a plurality of nanocapacitors.

14. A wireless communication system, comprising:

a wearable electronic device having a ring body including an outer cover and an interface disposed on an exterior of the outer cover, the ring body defining an annular receiving space within the ring body, a first substrate disposed in the annular receiving space, and a memory disposed on the first substrate having a plurality of gestures stored thereon correlated with a plurality of actions and a plurality of states of the wearable electronic device, the plurality of gestures are received at the interface by a plurality of capacitive plates and a processor disposed on the first substrate; and

a mobile computing device wirelessly connected with the wearable electronic device.

15. The wireless communication system of claim 14, further comprising an earbud wirelessly connected with the wearable electronic device and the mobile computing device.

16. The wireless communication system of claim 15, wherein the earbud has a housing with a second substrate, a speaker, and a microphone disposed in the housing.

17. The wireless communication system of claim 16, wherein the earbud has a light emitting diode disposed on the second substrate and aligned with an indicator on the housing.

18. The wireless communication system of claim 17, wherein the earbud has a heart rate sensor and a body temperature sensor disposed in the housing.

19. The wireless communication system of claim 15, wherein the plurality of actions are user-definable.

20. The wireless communication system of claim 19, wherein the plurality of gestures include tap gestures and swipe gestures.

21. The wireless communication system of claim 20, wherein the processor controls pairing actions of the wearable electronic device in response to receiving a set of gestures in a pairing state.

22. The wireless communication system of claim 20, wherein the processor controls notification actions of the wearable electronic device in response to receiving a set of gestures in a notification state.

23. The wireless communication system of claim 20, wherein the processor controls phone call actions on the mobile computing device in response to receiving a set of gestures in a phone call state.

24. The wireless communication system of claim 20, wherein the processor controls text message actions on the mobile computing device in response to receiving a first set of gestures in a text message state.

25. The wireless communication system of claim 24, wherein the processor controls email actions on the mobile computing device in response to receiving a second set of gestures in an email state.

26. The wireless communication system of claim 25, wherein a text message action includes inputting text into a text message in response to a subset of the first set of gestures, and an email action includes inputting text into an email message in response to a subset of the second set of gestures.

27. The wireless communication system of claim 20, wherein the processor controls music output actions on either the mobile computing device or the earbud in response to receiving a set of gestures in a music output state.

28. The wireless communication system of claim 20, wherein the processor controls music input actions on either the mobile computing device or the earbud in response to receiving a set of gestures in a music input state.

29. The wireless communication system of claim 14, wherein the memory has a plurality of notifications stored thereon correlated with a plurality of conditions.

30. The wireless communication system of claim 29, wherein the plurality of notifications are output by the processor disposed on the first substrate at a light emitting diode disposed on the first substrate.

31. The wireless communication system of claim 30, wherein the light emitting diode is aligned with the interface.

32. The wireless communication system of claim 30, wherein the plurality of notifications vary in color, number of illuminated flashes, and duration of each illuminated flash.

33. The wireless communication system of claim 32, wherein a set of notifications can be associated with state of charge conditions of the wearable electronic device, pairing conditions of the wearable electronic device, correspondence conditions at the mobile computing device, or application conditions of applications executed on the mobile computing device.

34. The wireless communication system of claim 14, wherein the wearable electronic device automatically communicates identification information stored in the memory to an external device.

35. The wireless communication system of claim 14, wherein the wearable electronic device communicates payment information to an external device.

36. A wireless communication system, comprising:

a wearable electronic device having a ring body including an outer cover and an interface disposed on an exterior of the outer cover, the ring body defining an annular receiving space within the ring body, a substrate disposed in the annular receiving space, and a memory disposed on the substrate having a plurality of notifications stored thereon correlated with a plurality of conditions; and

a mobile computing device wirelessly connected with the wearable electronic device.

37. The wireless communication system of claim 36, wherein the plurality of notifications are output by a processor disposed on the substrate at a light emitting diode disposed on the substrate.

38. The wireless communication system of claim 37, wherein the light emitting diode is aligned with the interface.

39. The wireless communication system of claim 37, wherein the plurality of notifications vary in color, number of illuminated flashes, and duration of each illuminated flash.

40. The wireless communication system of claim 39, wherein a set of notifications can be associated with state of charge conditions of the wearable electronic device, pairing conditions of the wearable electronic device, correspondence conditions at the mobile computing device, or application conditions of applications executed on the mobile computing device.

41. A wireless communication system, comprising:

a wearable electronic device having a ring body including an outer cover and an interface disposed on an exterior

of the outer cover, the ring body defining an annular receiving space within the ring body, and a first substrate disposed in the annular receiving space;  
a mobile computing device wirelessly connected with the wearable electronic device; and  
a plurality of earbuds wirelessly connected with the wearable electronic device and the mobile computing device, each of the plurality of earbuds having a housing with a second substrate, a speaker, a microphone disposed in the housing, and a light emitting diode disposed on the second substrate and aligned with an indicator on the housing.

**42.** The wireless communication system of claim **41**, wherein each of the plurality of earbuds has a heartrate sensor and a body temperature sensor disposed in the housing.

\* \* \* \* \*

专利名称(译)	带接口的可穿戴电子设备		
公开(公告)号	<a href="#">US9946457</a>	公开(公告)日	2018-04-17
申请号	US15/262758	申请日	2016-09-12
[标]发明人	WARREN MICHAEL K		
发明人	WARREN, MICHAEL K.		
IPC分类号	G08B23/00 G06F3/044 A44C17/02 G06F3/0346 G06F3/16 G06K7/10 G06F3/0488 H04W4/00 A61B5/0205 G06Q20/32 G05B19/048 A61B5/00 H04L12/24 H04W4/14 A44C9/00 A61B5/024 H04W68/00		
CPC分类号	H04W4/80 A44C17/0233 A61B5/02055 A61B5/6817 G05B19/048 G06F3/0346 G06F3/044 G06F3/162 G06K7/10297 G06Q20/322 G06F3/04883 H04W68/005 A44C9/00 A61B5/02438 G05B2219/35444 G06F2203/0384 H04L41/026 H04W4/14		
审查员(译)	DSOUZA, 阿道夫		
其他公开文献	US20170068437A1		
外部链接	<a href="#">Espacenet</a> <a href="#">USPTO</a>		

摘要(译)

公开了一种可穿戴电子设备。可穿戴电子设备包括环体和基板。环体具有外盖和设置在外盖外部的界面，环体在环体内限定环形容纳空间。基板设置在环形容纳空间中并具有多个电容板。

