

US009526421B2

(12) **United States Patent**
Papadopoulos et al.

(10) **Patent No.:** **US 9,526,421 B2**
(45) **Date of Patent:** **Dec. 27, 2016**

(54) **MOBILE WIRELESS CUSTOMIZABLE HEALTH AND CONDITION MONITOR**

(2013.01); **G08B 21/0453** (2013.01); **A61B 5/1112** (2013.01); **A61B 5/14551** (2013.01); **A61B 5/681** (2013.01); **A61B 5/721** (2013.01); **A61B 2562/0219** (2013.01);

(71) Applicant: **NRV-WELLNESS, LLC**, Richmond, VA (US)

(Continued)

(72) Inventors: **Amy Papadopoulos**, Ashburn, VA (US); **Cindy A. Crump**, Lovettsville, VA (US); **Bruce G. Wilson**, Williamsburg, VA (US)

(58) **Field of Classification Search**

CPC ... **A61B 5/0022**; **A61B 5/02438**; **A61B 5/721**; **A61B 5/6887**; **A61B 5/1113**; **G06F 19/3431**; **G06F 19/363**; **G06Q 50/22**; **G06Q 50/24**; **G08B 21/0446**; **G08B 21/0453**

(73) Assignee: **NRV-WELLNESS, LLC**, Richmond, VA (US)

See application file for complete search history.

(*) Notice: Subject to any disclaimer, the term of this patent is extended or adjusted under 35 U.S.C. 154(b) by 298 days.

(56)

References Cited

U.S. PATENT DOCUMENTS

2002/0029157 A1* 3/2002 Marchosky G06F 19/322
705/3
2006/0084847 A1* 4/2006 Reed A61B 5/0002
600/300

(21) Appl. No.: **14/089,324**

(22) Filed: **Nov. 25, 2013**

(Continued)

(65) **Prior Publication Data**

US 2014/0155705 A1 Jun. 5, 2014

Primary Examiner — Robert N Wieland

(74) *Attorney, Agent, or Firm* — Oblon, McClelland, Maier & Neustadt, L.L.P.

Related U.S. Application Data

(63) Continuation-in-part of application No. 12/862,828, filed on Aug. 25, 2010, now Pat. No. 8,618,930, which

(Continued)

(51) **Int. Cl.**

A61B 5/00 (2006.01)
A61B 5/024 (2006.01)

(Continued)

(52) **U.S. Cl.**

CPC **A61B 5/0022** (2013.01); **A61B 5/02427** (2013.01); **A61B 5/1117** (2013.01); **G06F 19/3418** (2013.01); **G06F 19/3475** (2013.01); **G06F 19/3481** (2013.01); **G08B 21/0446**

(57)

ABSTRACT

A method and system for wellness monitoring using one or more wellness indicator inputs and values is provided. One or more wellness indicator monitoring devices may be provided for measuring wellness indicator input. The wellness indicator monitoring devices may have one or more sensors and a microcontroller in communication with the one or more sensors. One or more servers may communicate with the one or more wellness indicator monitoring devices over a network. A processor may be configured to manipulate the wellness indicator input, and one or more output device may create a desired output based on the wellness indicator values.

20 Claims, 18 Drawing Sheets

Name	Icon	Indicator	Description
Total Wellness			Total score that combines all Wellness Indicator categories.
Activity			Score based on activity levels measured continuously while awake and asleep.
Physical Measures			Score based on vital signs compared to personal baselines, targets and/or population norms.
Stability			Score based on number of unstable events, falls or impacts.
Self Assessment			Score based on survey answers.

Related U.S. Application Data

is a continuation-in-part of application No. 12/568,116, filed on Sep. 28, 2009, now Pat. No. 8,378,811, which is a continuation-in-part of application No. 11/371,071, filed on Mar. 9, 2006, now Pat. No. 7,616,110.

(60) Provisional application No. 60/660,342, filed on Mar. 11, 2005.

(51) **Int. Cl.**

G08B 21/04 (2006.01)

G06F 19/00 (2011.01)

A61B 5/11 (2006.01)

A61B 5/1455 (2006.01)

(52) **U.S. Cl.**

CPC . *A61B 2562/0233* (2013.01); *A61B 2562/046* (2013.01); *G08B 21/0423* (2013.01)

(56) **References Cited**

U.S. PATENT DOCUMENTS

2015/0199480 A1* 7/2015 Dietz G06F 19/322
600/300
2015/0238097 A1* 8/2015 Teller A61B 5/02055
600/301

* cited by examiner

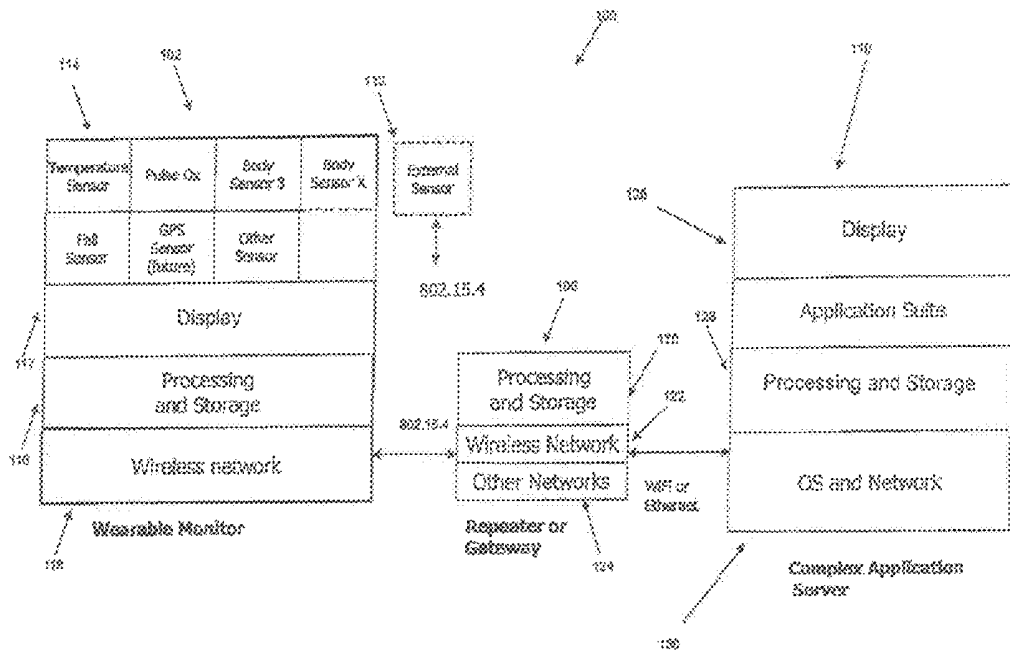

Fig. 1

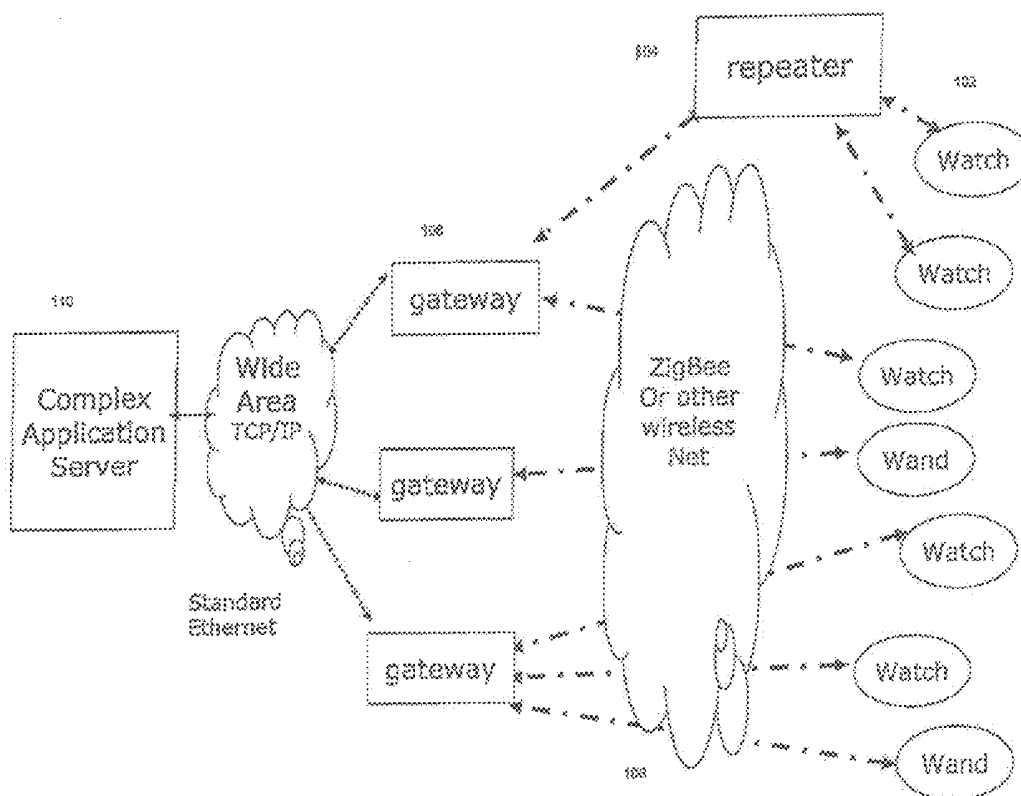

Fig. 1a

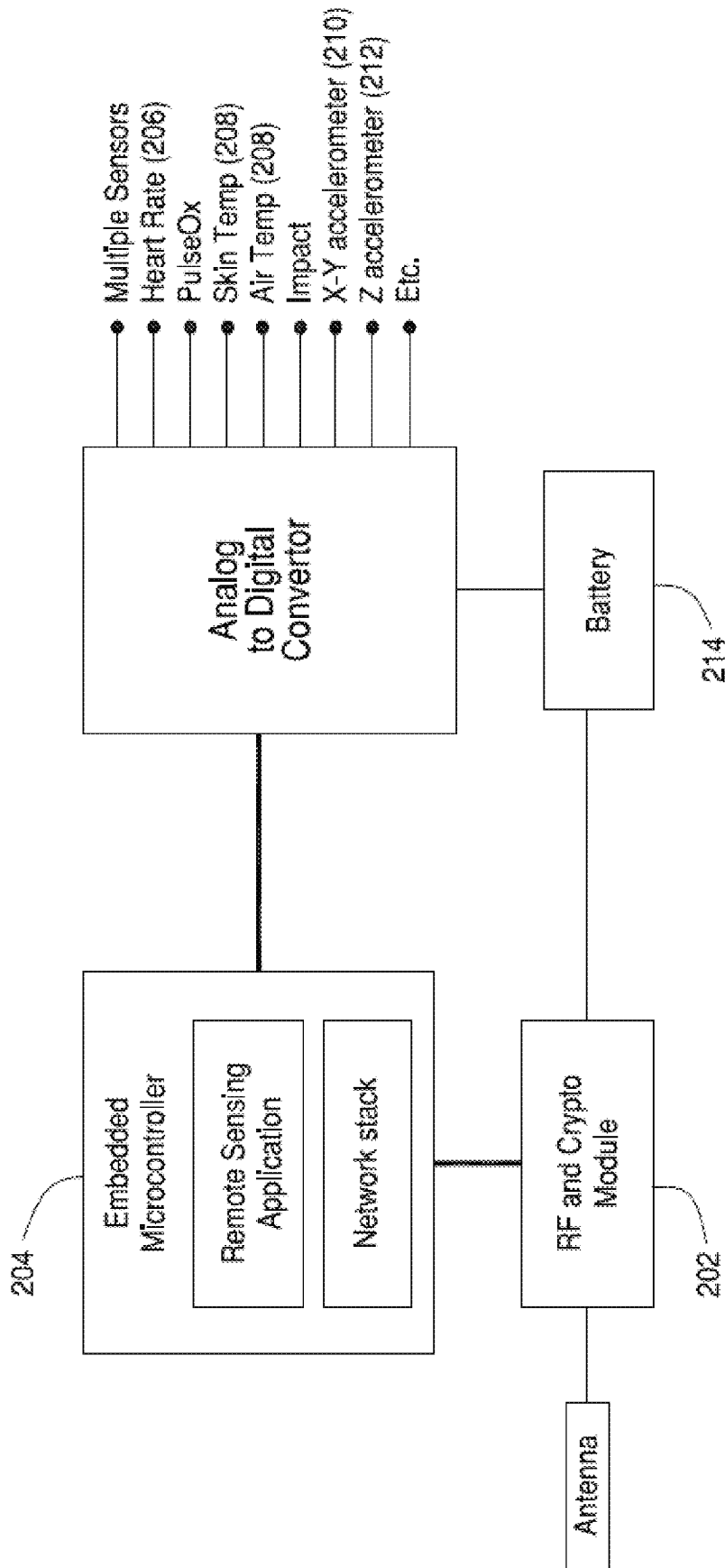

Fig. 2

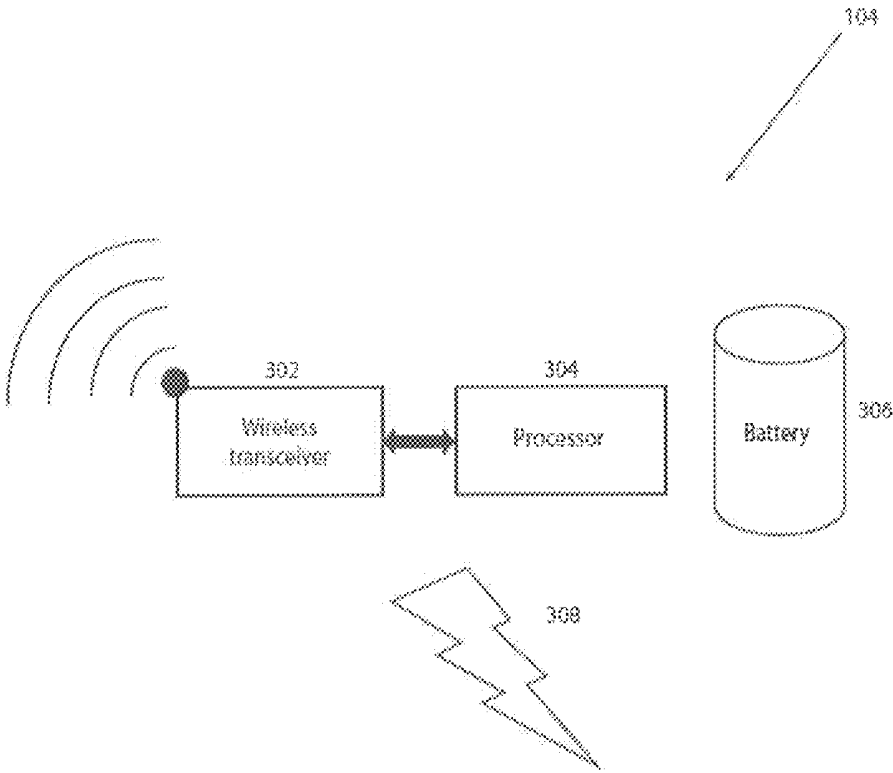

Fig. 3

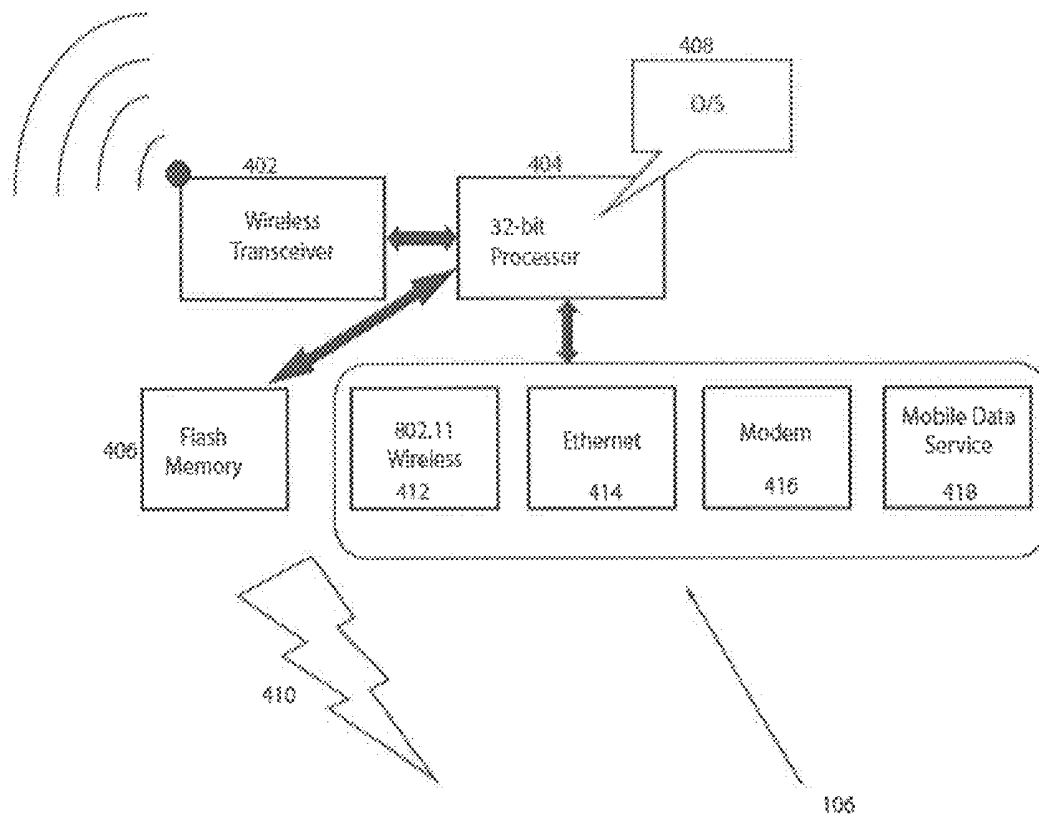

Fig. 4

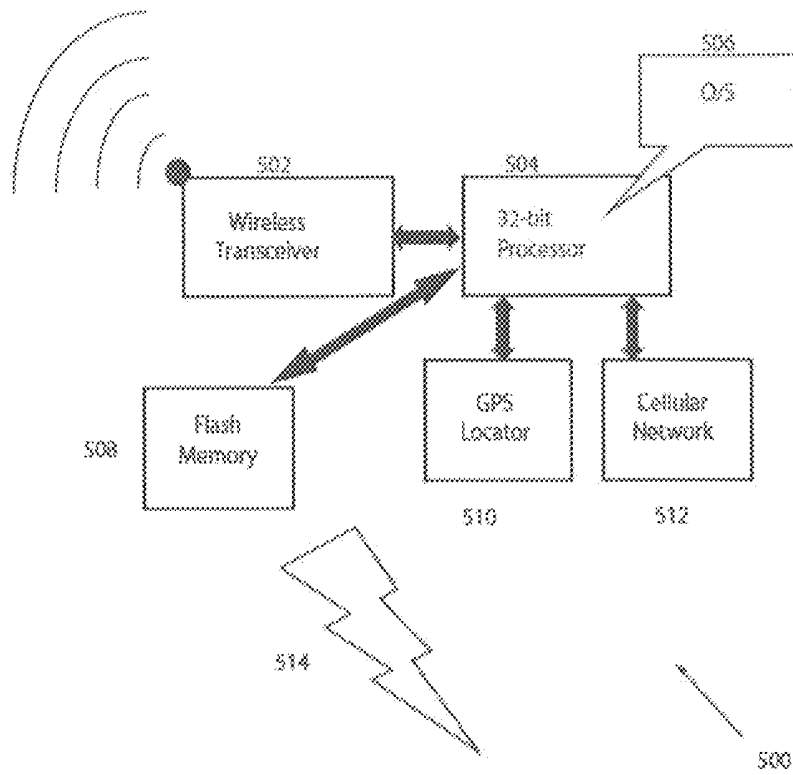

Fig. 5

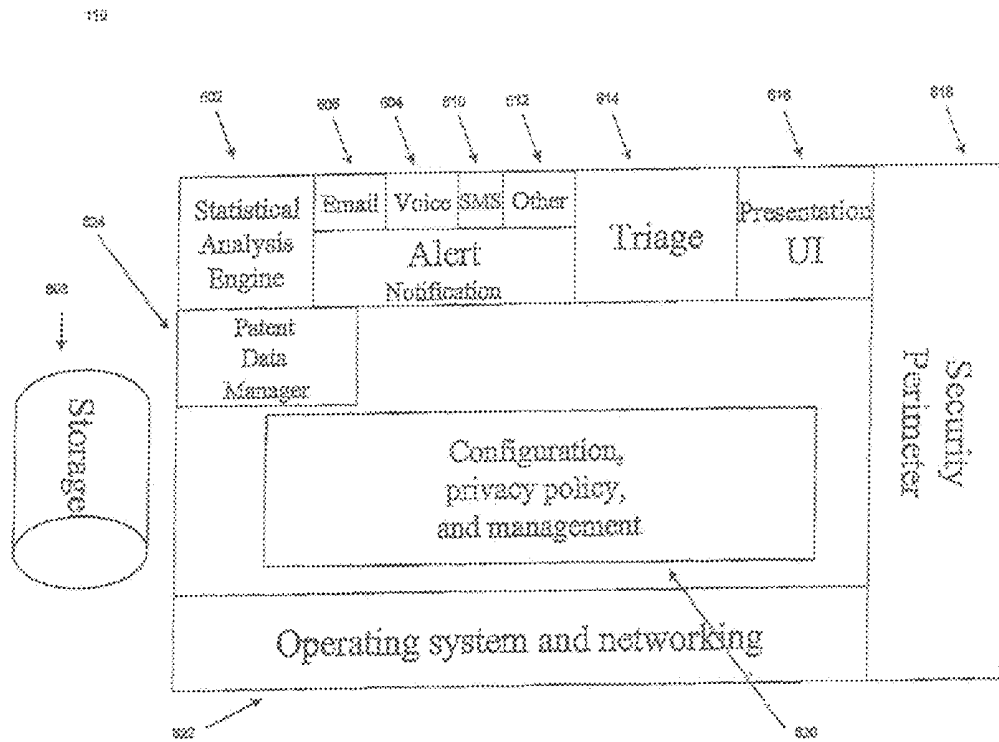
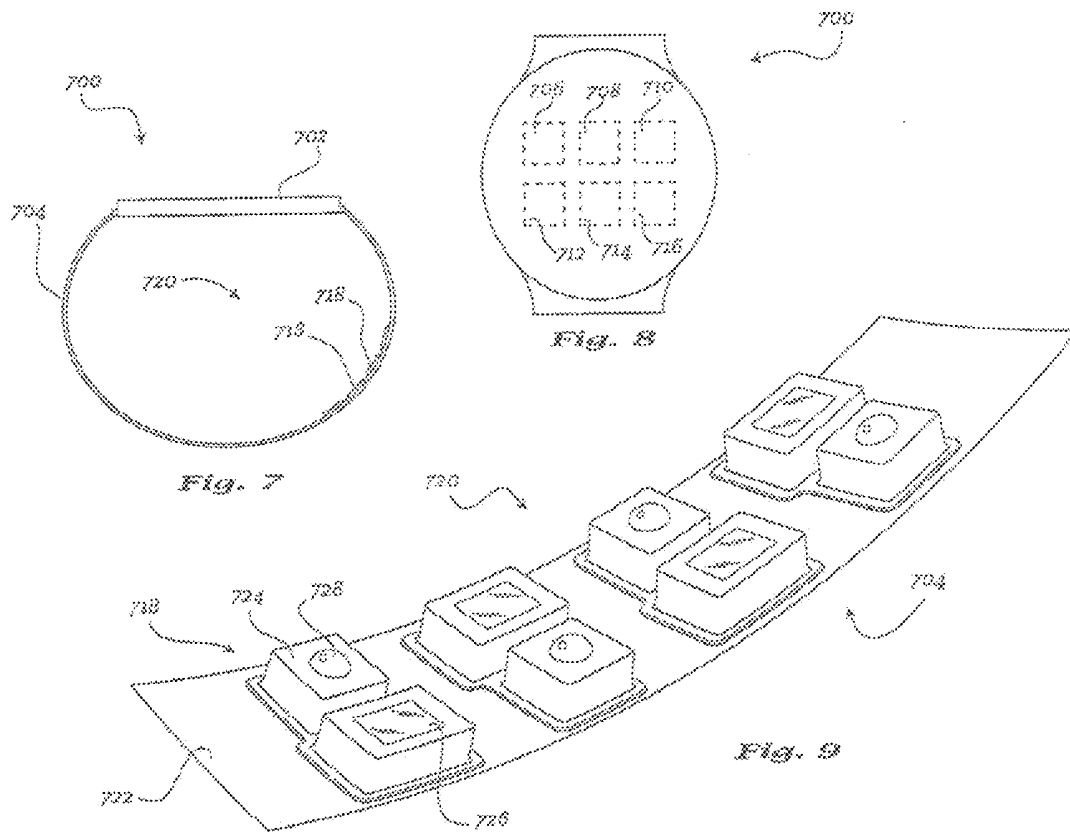

Fig. 6



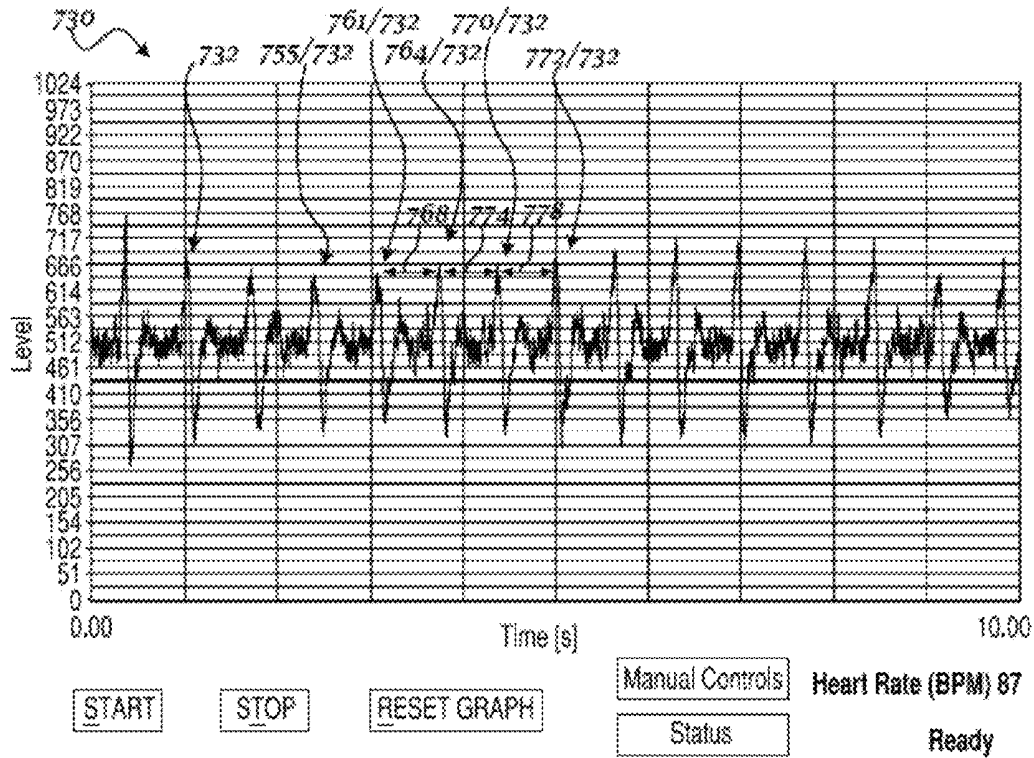

Fig. 10

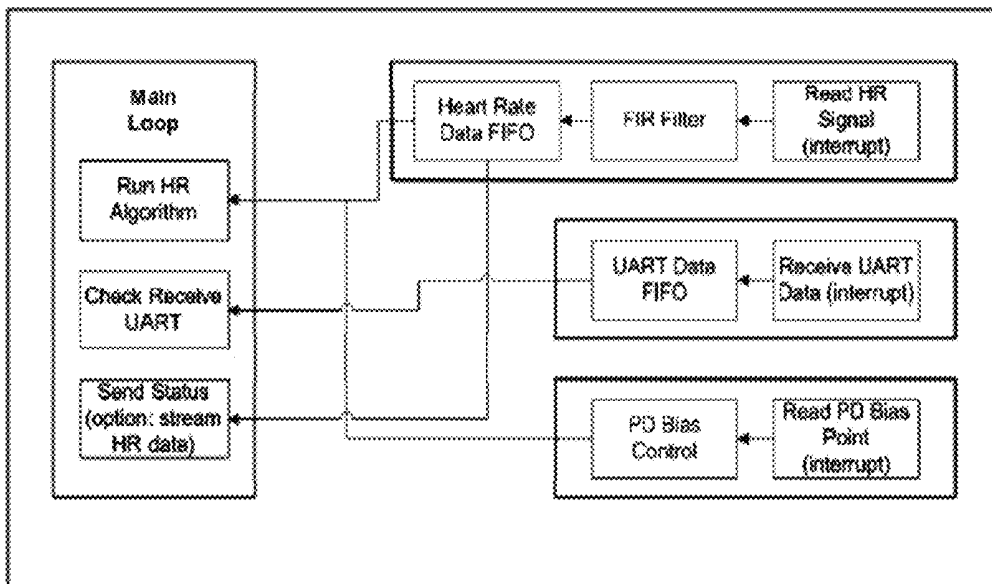

Fig. 11

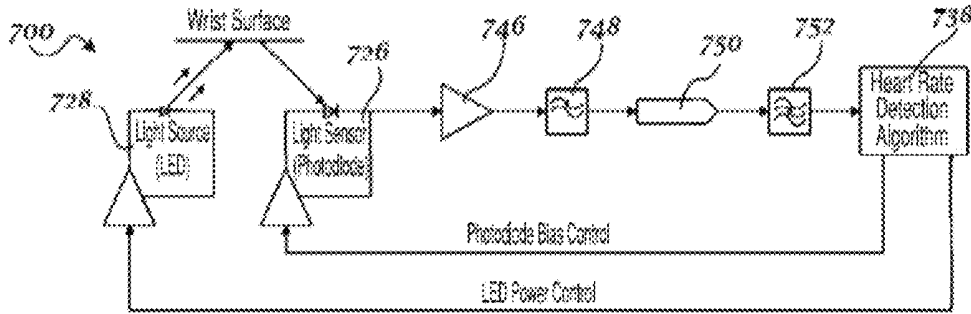

Fig. 12

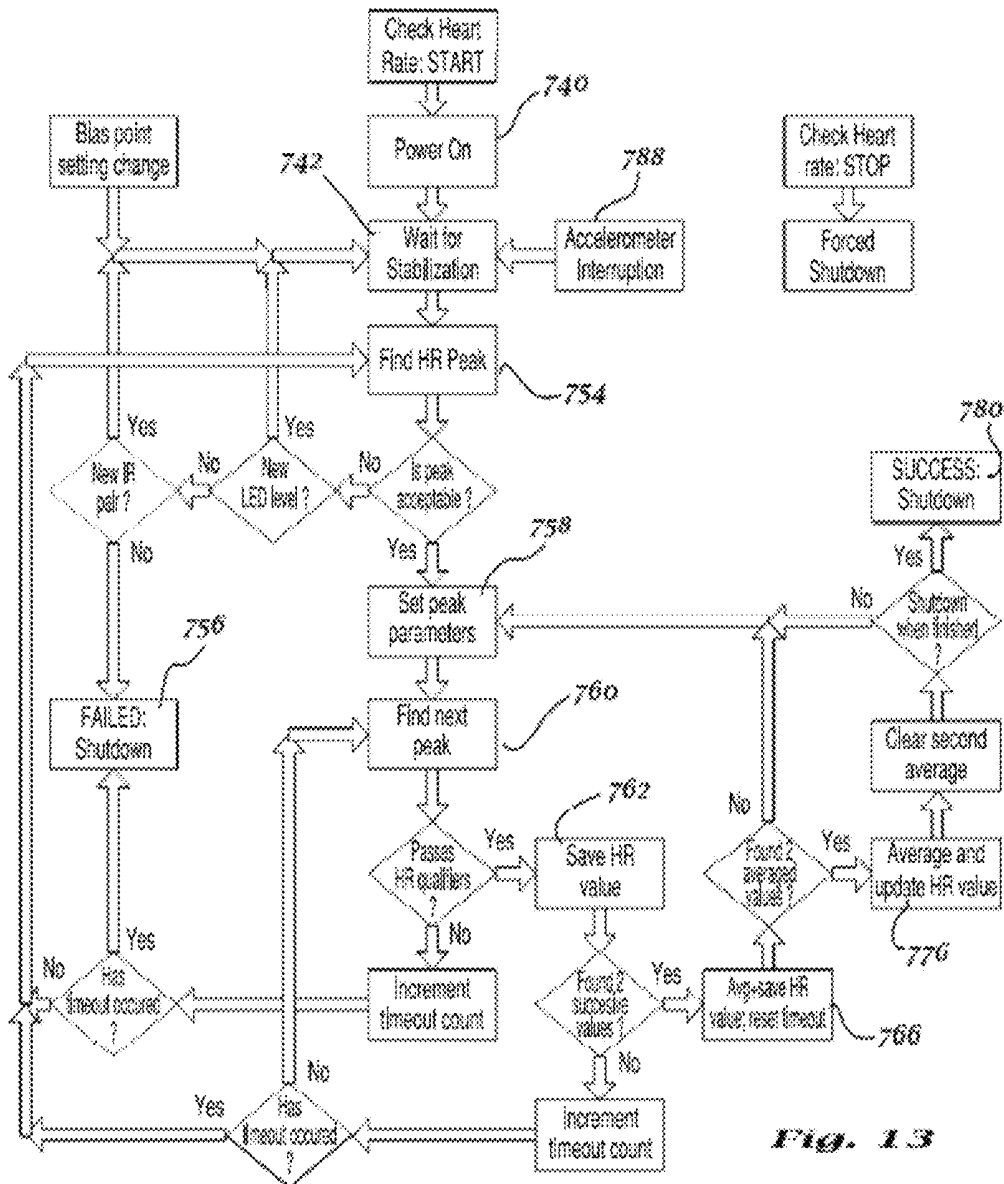

Fig. 13

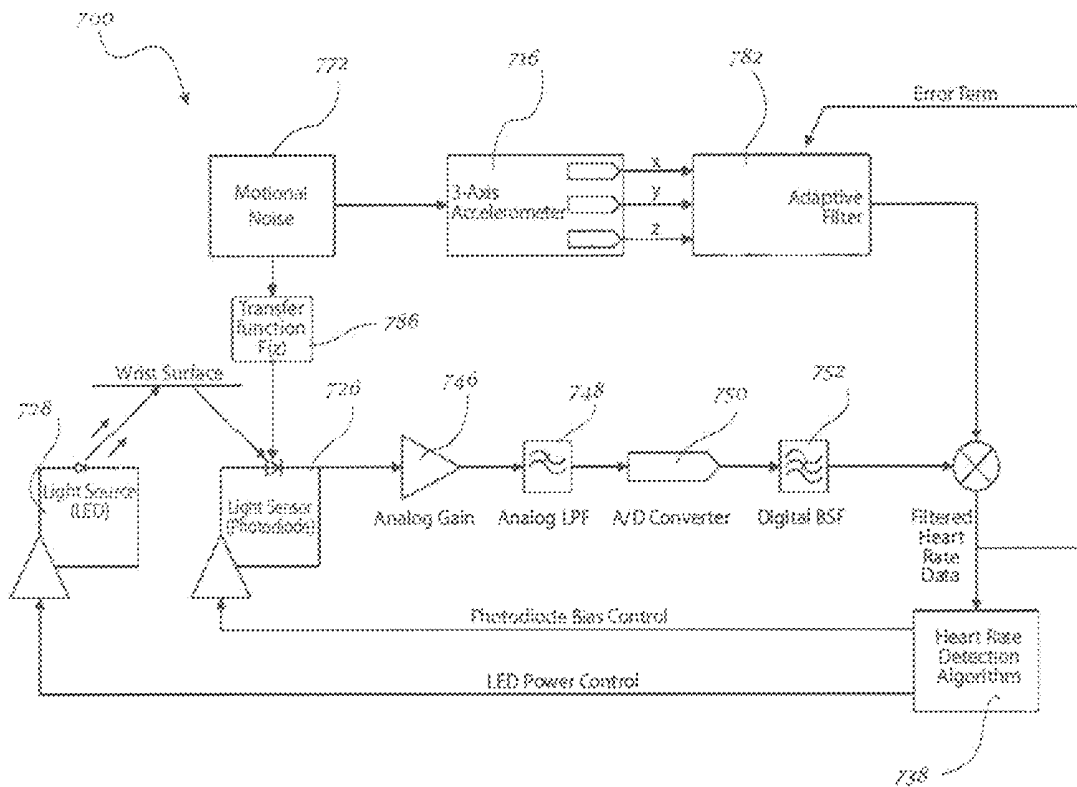

Fig. 14

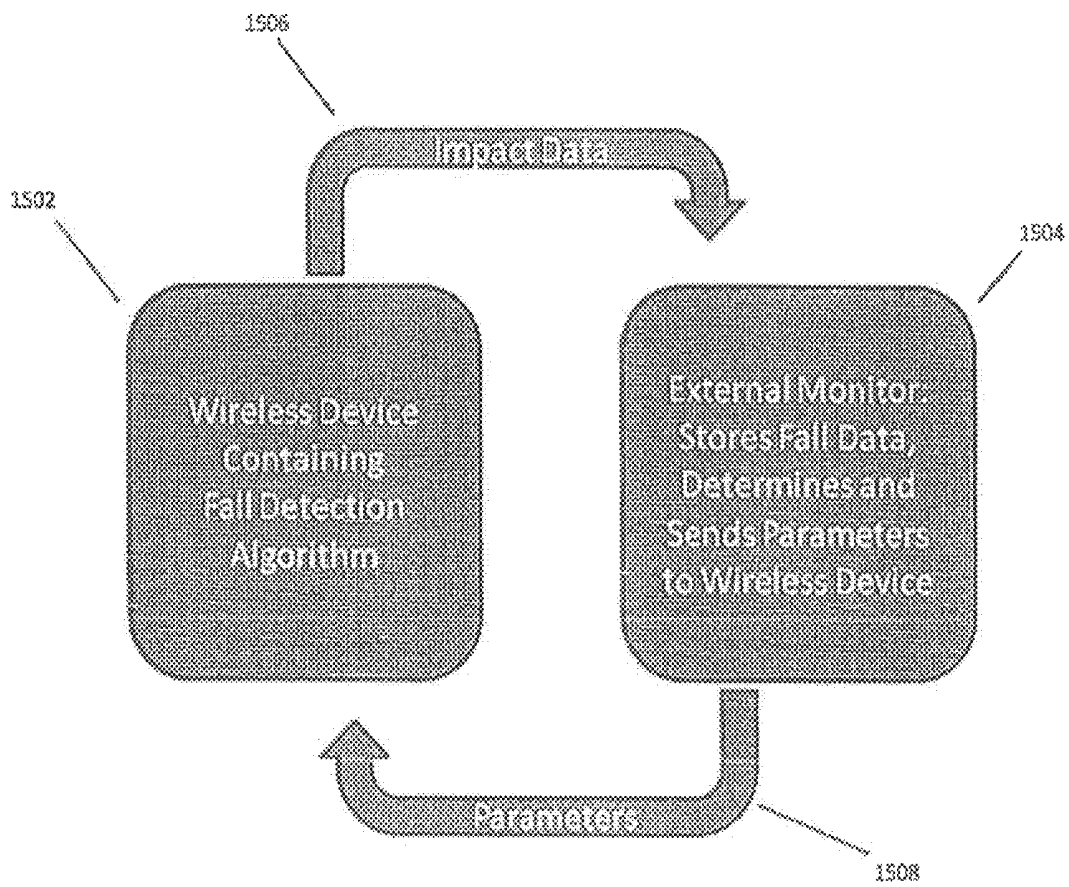

Fig. 15

1600

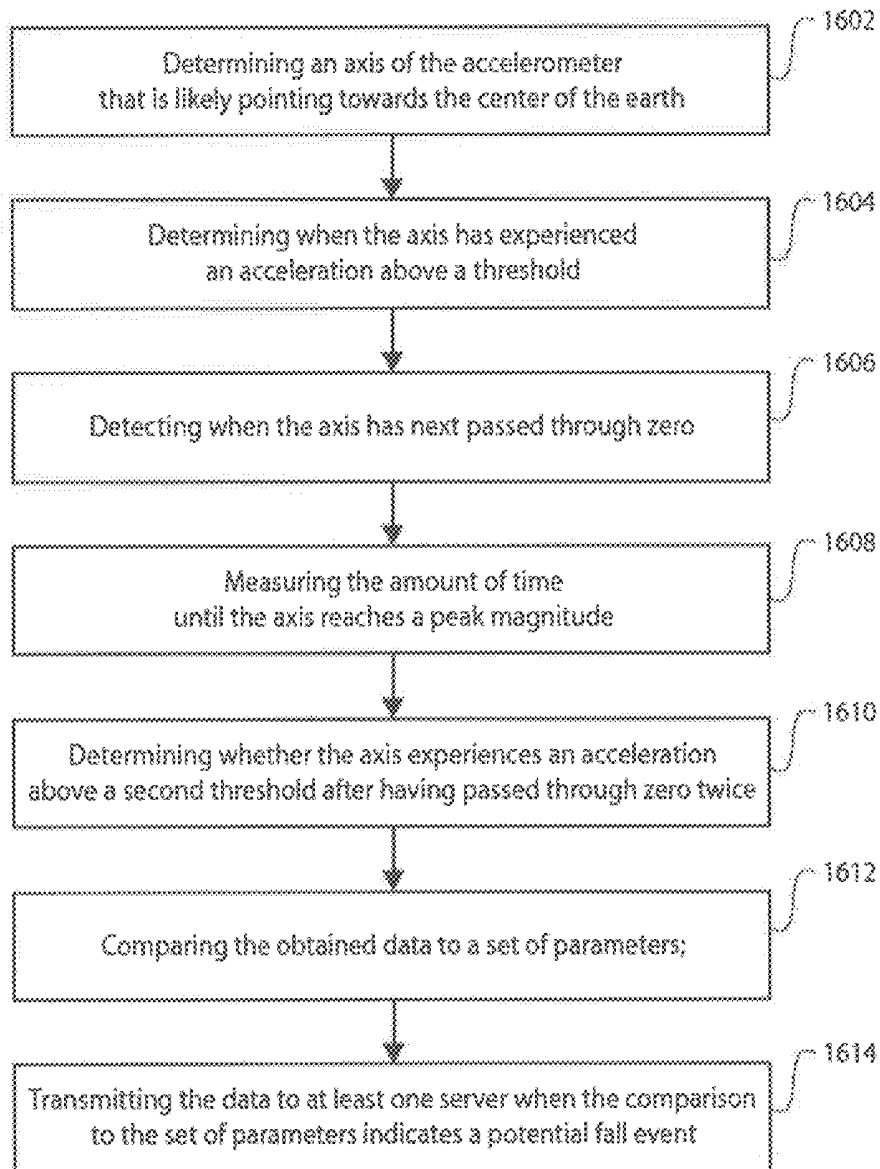

Fig. 16

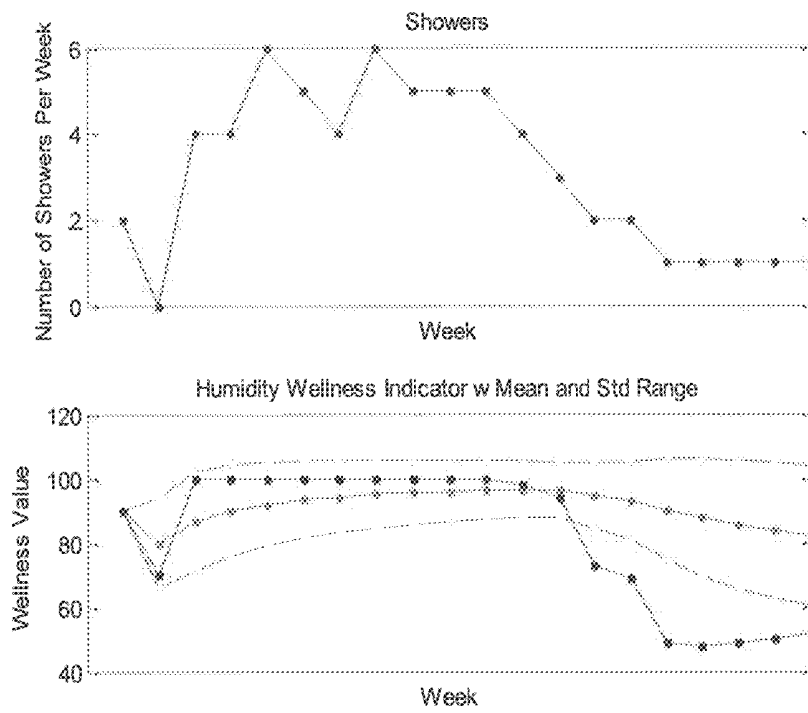

FIG. 17

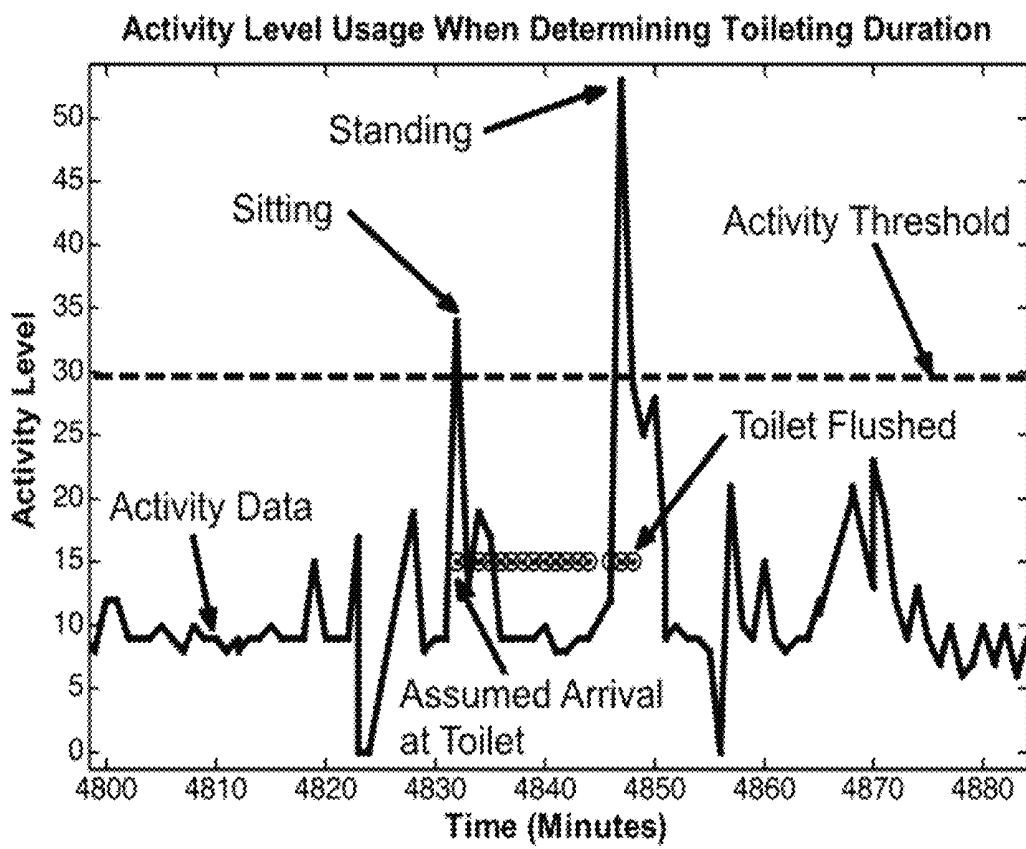

Fig. 18

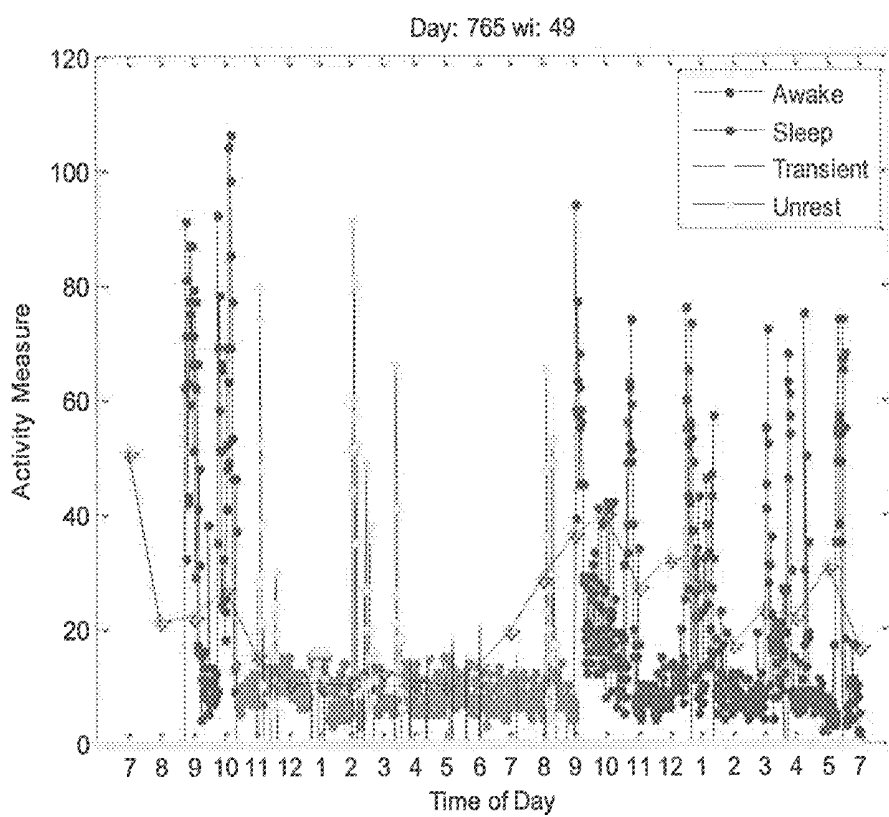

FIG. 19

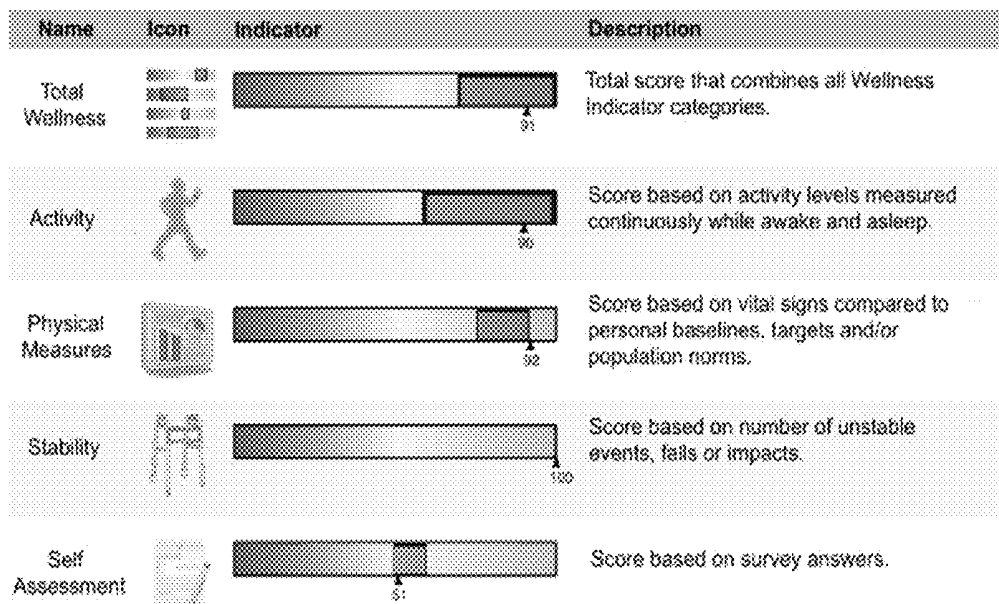

Fig. 20

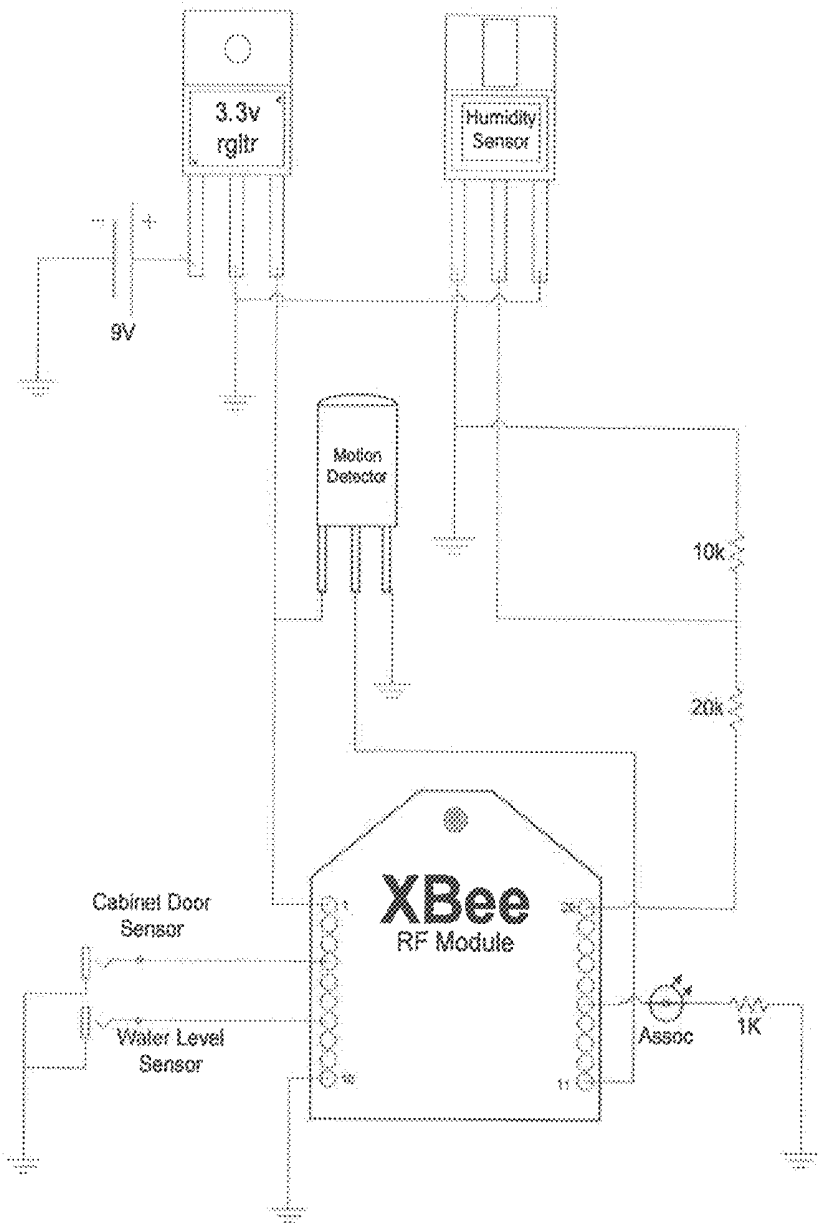

FIG. 21

**MOBILE WIRELESS CUSTOMIZABLE
HEALTH AND CONDITION MONITOR****CROSS-REFERENCE TO RELATED
APPLICATIONS**

This application is a continuation-in-part of U.S. patent application Ser. No. 12/862,828, filed Aug. 25, 2010, which is a continuation-in-part of U.S. patent application Ser. No. 12/568,116, filed Sep. 28, 2009, which is a continuation-in-part of U.S. patent application Ser. No. 11/371,071, filed Mar. 9, 2006 (now U.S. Pat. No. 7,616,110, issued Nov. 10, 2009), which claims priority under 35 U.S.C §119 to U.S. Patent Provisional Application No. 60/660,342, filed Mar. 11, 2005. The disclosures of the above-referenced applications are incorporated by reference herein in their entireties.

BACKGROUND OF THE INVENTION

Nursing homes and assisted care facilities employ a number of different methods and devices to monitor their patients. These devices are capable of monitoring physiological functions, but are generally used in isolation and not integrated with other devices. Some devices include fall alert buttons that require a patient to actively push a button to alert the staff of a care facility of a fall. This type of device, however, is not effective for a patient who has a cognitive impairment (such as dementia) is knocked unconscious or otherwise rendered incapacitated by a fall or other medical condition. Care facilities also use a variety of pressure pads and other sensors to provide an audible alert to indicate that a patient has left a desired location. These types of devices have reliability problems and require a high level of vigilance to constantly monitor the sensors. Moreover, none of these devices is capable of delivering private, targeted and configurable alerts for designated caregivers, nor do they provide centralized data collection for automatic charting and close monitoring of individual patients.

In addition to the above, many care facilities try to perform at least some vital sign monitoring. This may be limited to checking a patient's vital signs only once a week due to the time and cost required to have staff to perform these duties. However, when a patient's vital signs are checked only once a week, the declining health of a patient may only be detected after a health condition has worsened, eliminating the opportunity for early intervention. Thus, there can be an increase in a care facility's patient morbidity and mortality rate. Additionally, staff turnover and productivity can be an issue in care facilities that may need to spend more time replacing and training staff members to monitor sensors and patients' vital signs and to understand the patient's medical history and specific need for care.

Care facilities also have an interest in knowing the location of their patients at their facility, as well as patients that may be located remotely or living at individual homes and receiving care remotely. However, typical methods of monitoring patients and determining their locations involve the use of video cameras and closed-circuit television. Another method is the use of motion detectors to infer movement and activity level within a home. These systems typically require significant wiring or installation of equipment within a home and can be uneconomical for either home or multi-patient facility use. Moreover, motion detectors cannot distinguish between multiple residents or pets present in the home. Additionally, this may only provide an inference, but not a direct and objective indication, of the patient's well-being. Further, video-based services require a

high level of attention to the video feeds from the cameras and the identity of the people can be difficult to discern. There are additional issues in personal privacy and intrusion when using video or even motion detectors. Additionally, it is not usually practical to have cameras or a video monitoring system in the house of a remotely located patient.

Other facilities, such as hospitals, have also utilized patient and personnel tracking systems using radio frequency identification (RFID) badges. These devices can be worn by a person and may be passive devices or may transmit an RF signal that may be tracked from a centralized location in the facility. These devices, however, do not provide any other information besides the location of the wearer and they may not provide adequate transmission range. Also, RFID is limited in its memory so very little processing is available and there is no 2-way processing of event monitoring data. Other information that a care facility may desire to collect, such as a patient's vital signs, are not collected or transmitted by these devices. Additionally, the battery life on these devices can vary significantly depending on the type of RF signal transmitted and the amount and duration of transmissions from the device. Typically the devices only have a battery life of a few hours or several days before they require recharging or replacing the batteries. Other devices designed to transmit a signal having information about a patient may utilize cellular phone technology. These devices, however, often fail to get an appropriate cellular signal inside health care facilities and again require significantly more power and have a battery life of hours thereby rendering such devices impractical for long-term monitoring.

Yet other devices that have been used in battery-powered sensors include those using IEEE 802.15.1 Bluetooth wireless technology to replace cables. Enabling devices with Bluetooth does not in itself bring about an integration of separate monitoring devices for one patient. Indeed, there can be a limit of eight devices that may be joined together in a Bluetooth pico-net raising the question about scaling and the capacity to support hundreds of patients in a facility. The short range, typically on the order of ten meters, calls for a multimode extensive network strategy to support a healthcare facility, such as a mesh or partial mesh network, would provide for adequate coverage but also exceeds the specifications of Bluetooth. Merely replacing a cable from a monitor to a wireless Bluetooth enabled equivalent can result in rapid battery depletion if continuous monitoring is attempted.

Still other devices have been used for monitoring a patient's vital signs. These devices have been wearable and typically were capable of monitoring some vital signs, such as pulse rate and body temperature. These devices, however, typically only have the ability to display the information collected on a display that is either worn on the patient or on separate display that the collected data is downloaded onto. Some devices that monitor vital signs, such as pulse rate, require the patient to be relatively still to obtain an accurate reading. Other devices have included the ability to transmit location information to track the movement of a patient. These devices, however, do not have the ability to transmit collected data on the patient back to a central location for analysis. Further, these devices usually require a patient to wear a variety of different sensors and can be intrusive on the patient, embarrassing to wear, and prohibit some movement. These devices also only allow a patient to wear the device for a limited time, for example a few hours to several days, before the power source must be replaced or recharged.

Therefore, a need exists for a system that can track and monitor a patient using a wearable, form-friendly, low-power, wireless device that can be used to monitor the health and wellness of a person wearing the device during the person's daily activities, over long periods of time without the need to recharge the device, and without the constant surveillance of healthcare personnel.

As the percentage of the U.S. population aged 65 and older grows, it is increasingly important that the many factors affecting the health and wellbeing of this population are understood and addressed. Almost 90% of the elderly suffer from at least one chronic illness such as congestive heart failure (CHF), diabetes, hypertension, or dementia, while 77% suffer from multiple chronic diseases that are particularly complex to manage. Methods of surveying this population's health status and gathering longitudinal data such as activity levels, sleep patterns, physiological data and behavior patterns are needed. Poor behaviors include, for example, lack of activity, a factor cited as one of the major causes of chronic disease and also lack of the capacity for self-care which can be indicative of issues with cognition, depression or other functional issues associated with independent living. Other factors include failure to take prescribed medications according to the recommended schedule. Decreased stability, as tracked over long periods of time, points to increased risk of falls. Trends and rapid changes in vital signs provide an important profile that contributes to overall wellness and management of risks within specific disease care plans.

To understand and track the health of the elderly and or patients managing chronic conditions, data is needed by researchers, health policy analysts and, on a more timely and intimate basis, the caregiver, the medical team following the patient, and the patients themselves. Systems capable of easily collecting real-time, yet subtle health and wellness changes provide automated and easier access to insights into these diseases by providing more careful observations of physiologic changes thereby enabling earlier intervention, prevention and the potential for significant cost reductions and improved outcomes.

SUMMARY OF INVENTION

In one exemplary embodiment, a method for health and wellness assessment may be described. A server may be provided with data characterizing the physiological state, activities, or other attributes, of one or more patients using the system which is then used by the server to produce and maintain one or more patient-specific time-varying wellness indicators that characterize some aspect of a patient's health and wellness. Wellness indicator inputs may come from a variety of sources that may be analyzed, trended, and/or calculated in various ways to produce wellness indicators. Multiple wellness indicator input data types and values may be correlated and used in single-variable and multi-variable algorithms to produce wellness indicators. Wellness indicators may be displayed and alerted upon for evaluation and maintenance of the health and wellness of a patient. Wellness indicators may be used as indications of a need for timely intervention as part of the execution of a care plan for an individual patient (for example, in order to maintain health or prowess in a recovery or stability in managing a chronic illness, problem, or handicap).

In one exemplary embodiment, wellness indicator inputs may be obtained from a medical situational awareness system, consisting of embodiments of sensing devices with sensors in wearable form and in forms coupled to the

patient's environment, such as their bath, shower, toilet, rooms in their living space, and the doorways between them.

In one exemplary embodiment, external sensors, as part of a medical situation awareness system, may be attached to these environmental fixtures to provide measurement of and to transmit to a gateway with storage and processing and or to a server attributes such as temperature, humidity, water usage or levels, light levels, detected motion within a room, and door openings among other data inputs and attributes. These data may be correlated with other data such as physiological vital signs and an individual patient's activity level at all times of day and night in multi-variable algorithms that contribute to the derivation of wellness indicator values in one or more categories and summaries.

In another exemplary embodiment, a system for health and wellness assessment may be described. One or more sensing devices may be provided for measuring, capturing, and transmitting wellness indicator inputs. A sensing device may be a wearable monitor or an external sensor. The sensing device may have one or more sensors and a micro-controller and or radio frequency module in communication with the one or more sensors. One or more servers may communicate with the one or more sensing devices over a network. The server may have one or more processors that may be configured to manipulate the wellness indicator inputs, and one or more output device may create a desired output based on the wellness indicator inputs.

In another exemplary embodiment, accelerometer data in the monitor worn by a patient may be entered into an algorithm to derive data values that represent in compact form the activity level of the patient for a period of time, for example the prior 60 seconds, and transmit that data to the server. If the server or network is unavailable, the data may be stored in the monitor and may be buffered until it can be transmitted to the server. The server may store the data to provide a continuous historical record of the patient's activity level that is updated in real time as each time period ends and the new data point arrives. These longitudinal data points may be displayed and algorithms may be used to delineate periods of active wakefulness versus inactive periods of rest and apparent sleep. These data may be compared to other data such as door openings, changes in light levels, location, and other environmental data in multiple-variable algorithms that correlate the patient's behavior.

In another embodiment, data from the monitor worn by a patient, combined with data from external sensors in the environment, may be trended over time to provide a continuous yet nonintrusive automated monitoring of an individual patient's wellness between regular clinical checkups, and by detecting deviations from the individual's personal trended values, or baseline, provide inferences of changes in behavior that correlates with a change in health and wellness status. An example would be location data indicating the patient is in the bedroom, but at multiple times of the night the period of restful inactivity was broken by high activity levels measured by the accelerometer in the worn monitor, that correlates with a change in location to the bathroom, that correlates with the higher light levels due to turning on of a light, that correlates with a toilet flush. This multi-variable correlation may indicate the pattern is repeated a number of times during the night when one or none bathroom visits per night is the norm for the patient. This change in behavior pattern may be an indicator of an infection or other change or out of ordinary condition in health and wellness requiring intervention.

In another exemplary embodiment, some or all of the processing and display functions of server **110** may be embodied in a portable wireless tablet computing device, or similar convenient form factor. Additional data may be collected from the patient by displaying questions, perhaps with multiple-choice answers, that the patient will answer. These answers may provide a self-assessment or self-report of the patient's health and wellness that contributes valuable input data to the wellness indicators. The wellness indicators graphical presentation, as they are updated at regular intervals, may provide patients and their immediate family a better understanding of their current wellness and trends, to remind and or promote healthy behaviors and provide education and incentives to improve the scores.

BRIEF DESCRIPTION OF THE DRAWINGS

Advantages of embodiments of the present invention will be apparent from the following detailed description of the exemplary embodiments. The following detailed description should be considered in conjunction with the accompanying figures in which:

FIG. **1** shows an exemplary diagram of a health care monitoring system;

FIG. **1a** shows an exemplary diagram of a health care monitoring system;

FIG. **2** shows an exemplary diagram of a wearable monitor;

FIG. **3** shows an exemplary diagram of a repeater;

FIG. **4** shows an exemplary diagram of a gateway;

FIG. **5** shows an exemplary diagram of a mobile gateway;

FIG. **6** shows an exemplary diagram of a server;

FIG. **7** shows a side view of an alternative monitor that may be used with the system shown in FIG. **1**;

FIG. **8** shows a bottom view of the monitor shown in FIG. **7**;

FIG. **9** shows a perspective view of a band that may be used with the monitor shown in FIG. **7**;

FIG. **10** shows a chart readout of a raw signal that may be detected by sensors and analyzed by the monitor shown in FIG. **7**;

FIG. **11** shows a heart rate and heart rate variability code structure that may be used with the monitor shown in FIG. **7**;

FIG. **12** shows a schematic of the monitor shown in FIG. **7**;

FIG. **13** shows a heart rate and heart rate variability algorithm that may be used with the monitor shown in FIG. **7**; and

FIG. **14** shows an alternative monitor that may be used with the system shown in FIG. **1**.

FIG. **15** shows an exemplary algorithm for fall detection

FIG. **16** shows an exemplary method of detecting a fall,

FIG. **17** may show an exemplary embodiment of a wellness indicator.

FIG. **18** may show an exemplary analysis graphic, showing identification of toileting event with determination of length of time spent on the toilet.

FIG. **19** may show an exemplary embodiment of an activity graphic showing night time activity level, periods of unrest and transient movements

FIG. **20** may show an exemplary embodiment of a wellness dashboard.

FIG. **21** may show an exemplary schematic of a bathroom sensor configuration.

DETAILED DESCRIPTION OF THE INVENTION

Aspects of the present invention are disclosed in the following description and related figures directed to specific embodiments of the invention. Those skilled in the art will recognize that alternate embodiments may be devised without departing from the spirit or the scope of the claims. Additionally, well-known elements of exemplary embodiments of the invention will not be described in detail or will be omitted so as not to obscure the relevant details of the invention.

As used herein, the word "exemplary" means "serving as an example, instance or illustration." The embodiments described herein are not limiting, but rather are exemplary only. It should be understood that the described embodiments are not necessarily to be construed as preferred or advantageous over other embodiments. Moreover, the terms "embodiments of the invention", "embodiments" or "invention" do not require that all embodiments of the invention include the discussed feature, advantage or mode of operation.

Referring generally to FIGS. **1-6**, a medical situational awareness system that can monitor the health, location or well-being of patient is shown. The use of the term "patient" is exemplary. It should be understood that this invention can be used to monitor any individual regardless of their state of health and regardless of whether they are under that care of a physician. The system may include a user-friendly, internet-based interface and tools for analyzing data. The system may also include a scalable, customizable database for management and codification of the uncertain relational knowledge gathered regarding multiple data types that may be collected about the patient. This database can include advanced analytic tools. Additionally, the system can include a Bayesian advanced analytic software tool that can take the uncertain relational knowledge gathered and develop a Bayesian relational network. This network may then be used to create a predictive model of medical condition for the monitored patient. The model may be used, for example, to filter false positives, incorrect data or inaccurate data. This may be accomplished by including other data types that correlate in a health model. This autonomic process could allow for an effective wearable monitoring system because the event data from the sensors, which would normally require significant analysis time by an operator to ensure an accurate picture of the patient's overall health, is provided automatically without necessarily requiring operator involvement. Further, the system may have a graphical interface that can be used for results analysis or health care suggestions. This system may be employed in any of a variety of situations, for example hospitals, extended care or skilled nursing facilities, senior communities, nursing homes, private homes, or any other situation where it is desirable to monitor and provide care for a patient.

FIG. **1** shows an embodiment of a health care monitoring system. System **100** may have a variety of components, such as monitor **102**, gateway **106** and server **110**. Monitor **102**, gateway **106**, and server **110** may transmit data to each other and receive data from each other through any of a variety of wireless transmission protocols. Further, monitor **102** may include sensors **114** to detect physiological, locational and other data from a wearer of monitor **102**. These sensors may include, but are not limited to a temperature sensor, a pulse oximetry sensor, a variety of body sensors, a fall detection sensor, and a location sensor, as well as any of a variety of

other sensors. Additionally, external sensor **112** may be disposed separately from sensors **114** to detect and transmit data from a location apart from monitor **102**. Monitor **102** may further include processing and storage capabilities **116** for processing and storing the data from the sensors as well as data received from outside sources. Monitor **102** may also include display **117** for facilitating communication to the patient of patient reminders and messages from server **110** or gateway **106**. Also, mesh network **118** may be utilized with monitor **102**. Mesh network **118** may include a variety of repeaters so as to allow for the transmission of data over significant areas as well as for use in providing location information of a wearer of monitor **102**.

Gateway **106** can communicate wirelessly with monitor **102** and server **110** and may also include processing and storage capabilities **120**, which may be able to process and store data transmitted from monitor **102**, as well as data generated by gateway **106** and data received from server **110**. Gateway **106** may be part of a wireless local area network (LAN) **122** and also part of other networks **124**, allowing it to communicate with other devices, for example, over the Internet.

Server **110** may communicate with gateway **106** over network **130** to both send and receive data. Server **110** may include processing and storage capabilities **128**, which may be used for processing, interpreting and storing data received from gateway **106** and monitor **102**, as well as performing other analyses, such as eliminating false alarms, refining wellness indicator scores and predicting future events. Further, server **110** can include a display **126**, such as a nurse's display, where a person may access the data stored and processed by server **110**.

In another embodiment shown in FIG. **1a**, a system **100** for monitoring the health, location or well-being of a patient is shown. Here, a patient may use a device such as a wearable monitor **102**. The monitor **102** can be a hardware device taking the form of an arm band or a wrist band or a device that can be applied to the skin via a bandage, as a non-limiting example. In a further embodiment, the monitor **102** can be wearable and not interfere with any range of motion or actions of a patient. The dimensions of the monitor **102** may also be small, for example, 1"×1"×3" or smaller. There may be a variety of sensors, such as a pulse sensor, temperature sensor and a mobility sensor, integrated into the monitor **102**, as a few non-limiting examples. Further, a panic button may be disposed on the monitor **102**, allowing a wearer or other patient to send a signal to a remotely located party, such as a caregiver or a facility's server. Additionally, the monitor **102** may incorporate "fall detection," which can detect if a patient falls down or otherwise moves in a manner that could result in an injury. The fall detection may use any of a variety of sensors, alone or in combination, for example, piezoelectric-based, accelerometer-based and gyroscopic-based. The sensor or sensors may be incorporated in the monitor **102** whether it is worn on a wrist of a patient or anywhere else on their body. Further, the fall detection portion of the monitor **102** can also send a signal to a caregiver or a facility's server.

In an additional embodiment of the monitoring system, the wearable monitor **102** can send a wireless signal to a repeater **104**. The repeater **104** can be a custom hardware device that may be battery or AC powered. The repeater **104** may also be installed in any location where additional routing nodes may be required, to provide further wireless coverage and allowing the wearable monitor to communicate with a smart gateway.

Further, in the system shown in FIG. **1a**, a smart gateway **106** may be utilized to further transmit a wireless signal. In one exemplary embodiment, the smart gateway **106** may be a hardware device that integrates IEEE 802.15.4 ZigBee wireless networking components with Ethernet, 802.11 wireless routers or a modem. IEEE 802.15.4 may be used as it allows a large number of nodes to join the network, thus permitting a large number of patients to be monitored. Communication may occur over the 2.4 GHz band, which is unlicensed and available in most locations, allowing for a single product to be utilized throughout the world. Additionally, to avoid congestion caused by other devices using this band, the IEEE 802.15.4 ZigBee standard may use 16 channels in the 2.4 GHz band, allowing the monitor **102** to utilize less crowded channels when necessary. Likewise, any spectrum, which may be licensed for the purpose of monitoring or may be not licensed, such as the 5 GHz spectrum, may be used to avoid potential interference with other devices. Also, because 802.15.4 has a relatively long range, larger scale monitoring can occur. This transmission protocol is also a very low power protocol, allowing for extended use of the monitors, and the low data rate and limited interference with other devices allow for 802.15.4 devices to work in environments where other RE devices are already operating. However, in other exemplary embodiments, any other type of wireless networking devices, components or protocols may be used with the gateway **106**. The gateway **106** can collect the event data generated by the wearable monitor and may send real-time medical alerts directly to a caregiver or, alternatively, to a facility's server for further analysis and action.

Although the above embodiments discuss the IEEE 802.15.4 ZigBee wireless standard, any wireless communication protocol known by a person of ordinary skill in the art could be used for transmitting and receiving. In another embodiment, any wireless communication protocol known to a person having ordinary skill in the art that has economical power consumption, reasonable data rates, limited interferences, and sufficient range may be used.

After the wireless signal shown in FIG. **1a** is transmitted from the smart gateway **106**, it can pass through a local area network **108** to a server **110**. The server **110** can be a software application that allows a nursing home facility or other care giving or healthcare facility to track the incidence of fall reports, medical emergencies and other transmissions of the wearable monitor at their site. The server **110** can also have the ability to send targeted real-time medical alerts to facility employees and can escalate these alerts to various members on the staff, as well as track response times, for example, to the medical alerts. The server **110** may also provide statistics on the vital signs of the residents as well as the location of the residents. Further, the server **110** may be able to perform intelligent analyses of event data, and of multiple correlating data types in health models created by the system, to minimize false alarms and allow for predictive decision support to healthcare providers, which could lead to improved care. Data transmitted to the server **110** may be forwarded to any of a variety of devices including those incorporating external sensors **112**, and be viewable over the Internet or a local area network. The data may then be reviewed and analyzed by an authorized person at the remote location of the external sensors **112**.

In yet another embodiment, the system **100** may be used in either a health care facility or at an individual's home. Further, a monitor **102** that functions in a healthcare facility may also change locations to the individual's home or another location that is compatible with the system. Addi-

tionally, if the user moves or transitions back to the original care facility, the monitor **102** can continue to work seamlessly. Further, the same equipment for system **100** that is used in a health-care facility may be used for a patient at their home, as the equipment is typically relatively inexpensive. The message protocols used in the system can provide end-to-end integrity and security in the data from each wearable monitor and each external sensor **112** as the data is transmitted over wireless networks to the Internet or public carrier networks to reach the server having patient's records.

FIG. 2 shows a more detailed diagram of the wearable monitor **102**. The monitor **102** may be used to monitor the health and mobility of the wearer. In one embodiment, the monitor **102** may be a low-cost, high volume device that can be replaceable if it is lost or broken. The monitor **102** may also be customized based on whether or not it is being used in a wearer's home or at a care facility. The monitor **102** can include a wristband device, which may be a physically attractive, compact device capable of being worn on the wrist, similar to a wrist watch. Alternatively, the wearable monitor **102** may be a pager-sized device that can be attached to the belt of a wearer or to an armband or leg-band on the wearer. In yet another embodiment, the wearable monitor **102** could be formed so that it is integrated in a bandage or similar adhesive device that may be securely worn anywhere on the body of a wearer.

Although some embodiments have been described as including a wrist watch or pager-sized device, or the same divided into two or more smaller pieces, or any configuration known to one having ordinary skill in the art that would attach to the body securely and not inhibit or intrude upon the mobility, nor limit the range of motion of a user may be used. A version of the wearable monitor called a "wand" may be carried by authorized healthcare and support personnel. The wand can function to communicate with the server or other system components to verify patient identity, verify proper operation of the patient's wearable monitor, verify that the healthcare personnel have responded to medical alerts and notifications made by the system and have attended to the needs of the patient, as well as verify or determine any other relevant information.

The monitor **102** may have a variety of internal components, regardless of whether the wearer has the wristband device or the pager-sized device. An 802.15.4 wireless transceiver **202** may be disposed in the monitor. Alternatively, another wireless transceiver may be used with monitor **102**. Additionally, an antenna can be disposed in the device. The antenna may be able to produce a significantly uniform signal having a significantly uniform signal strength emanating to all directions (substantially isotropic) regardless of the orientation of the monitor due to change in position of the wearer of the monitor. The antenna may further be optimized for communication in an indoor environment. A processor **204** may also be housed in the device. In an exemplary embodiment, the processor **204** can be an ultra-low power 8-bit processor. Additionally, a processor **204** may be utilized that has a hibernate mode where only micro-amps of current are used to power the hibernating device, and which only "wakes up" or activates to process events which can minimize power requirements and extend battery life. Flash memory (not pictured), or any type of solid-state memory known to one having ordinary skill in the art, may also be employed in the monitor **102**. The flash memory can contain the latest sensor data and alerts when the wearable monitor is out of the range of a network, the protocol stack as well as firmware developed to react to events generated by the sensors.

In addition, the monitor can include any of a variety of sensors. These sensors can include medical-grade sensors which can be employed to determine the health of the wearer. For example, the sensors may include a pulse sensor **206**, a temperature sensor **208** and accelerometers for the x-y axis **210** and z axis **212**, allowing for mobility detection and fall detection. Further the mobile device can include a battery or batteries **214**. The battery or batteries **214** may be such that they allow for the device to run off of the battery power for more than six months. Any of a variety of batteries may be used in both the wristband and pager-size applications. The battery or batteries **214** may also be any of a variety of rechargeable batteries, and may therefore reduce the need for replacing battery or batteries **214**.

Further embodiments of the monitor **102** not pictured in FIG. 2 may include a blood pressure sensor, a pulse oximetry sensor (to provide more accurate blood oxygen saturation determination mechanisms), a temperature sensor, respiratory rate sensor, wireless network-based location sensor and GPS or cell-based geo-location and E911 service. Further embodiments of the monitor **102** not pictured in FIG. 2 may include sensors for military, hazardous or similar applications, for example a blast pressure sensor or a bio-contagion sensor. Individual sensors may be utilized to monitor these events or a single sensor may be utilized to perform one or more of the tasks. Additionally, a shock meter that may use galvanic skin resistance and skin temperature, along with event analysis software to provide an early detection of shock may be incorporated.

Although the above preferred embodiments discuss a blood pressure sensor, laser pulse oximetry sensor, a temperature sensor, respiratory sensor, GPS and E911 services, any other sensor or service known to one having ordinary skill in the art may be used or incorporated into the device.

The wearable monitor **102** can use wireless networking components in order to send vital sign data, location information and medical emergency alerts. In one exemplary embodiment, 802.15.4 ZigBee wireless networking components (e.g. transceiver **202**) may be used. In another exemplary embodiment, any other wireless networking components may be used that may be disposed on monitor **102** and provide for transmitting and receiving data wirelessly. Additionally, the monitor **102** can incorporate GPS locating capability to provide detailed location information of the wearer. Further, a cellular modem may be incorporated onto the monitor **102**, allowing the wearer to be monitored from remote locations and, optionally, interacting with ZigBee or equivalent-enabled mobile phones.

The software that can be used in the wearable monitor **102** can be designed to be small, thus limiting the amount of processing power required and therefore extending battery life. Additionally, the software incorporated on the monitor **102** can be programmed into firmware. One portion of the software can include an IEEE 802.15.4/ZigBee protocol stack or any alternative wireless network protocol stack. This combination can provide the ability for the wearable monitor **102** to wirelessly communicate with one or more repeaters and gateways. Additionally, in one embodiment, since the wearable monitor **102** may require very low power consumption, it can be considered an end node that does not route data, and thus may be considered a reduced function device (RFD) under the IEEE 802.15.4 standard. However, in other embodiments, the monitor **102** can have full routing functions and utilize any known wireless standard. Further, the software may also be able to respond to beacons or directed messages from a gateway device that is requesting current sensor data to be sent. Also, in a further embodiment,

the data transmitted from the wearable monitor **102** can be encrypted, for example, using the security capabilities of the 802.15.4 standard or any other Advanced Encryption Standard (i.e. AES 128 or AES 256) scheme known to one of ordinary skill in the art may be used.

Additional software may be used for processing sensor data and ensuring that out of range data is processed for all of the sensors that are integrated into the device. For example, in the case of fall detection, the software should be able to process the data and determine if a fall has occurred or if a typical movement has occurred. Also, sensor data may be time stamped, gathered and sent to a gateway on a periodic basis for statistical tracking of norms. In a further embodiment, if there is a network failure, data or high-water mark sensor data can be latched and transmission can be retried until transmission is confirmed. Additionally, the wearable monitor **102** can also test battery power of battery **214** on a regular basis and may also transmit a "low battery" alert when battery life has decreased below a predetermined amount, for example, 20% of the remaining battery life. Alternatively, a "low battery" alert may be transmitted at any predetermined amount at or below 50% of the remaining battery life. Additionally, battery full status when recharging is completed can also be transmitted.

An exemplary repeater is shown in FIG. 3. A repeater **104** can ensure that adequate wireless coverage is maintained across the facility or home where the wearer of the monitor is located. In one embodiment, a repeater **104** can collect the statistics and alerts generated by the wearable monitor **102** and transmit real-time medical alerts to a caregiver or a care facility's server. Increasing the number of repeaters, for example in a mesh pattern or any other pattern known by one of ordinary skill in the art that will provide the desired coverage, in a given location, can also reduce the number of gateways that a home or facility may need. Additionally, the number of repeaters may be increased to support a virtually unlimited number of monitored patients and, additionally, determine the location of any individual patient. Repeaters can also compensate for the signal sent from an ultra-low power wearable monitor, which may have a limited transmission range. The repeater **104** can use a variety of hardware and software and may be changed or customized depending on the type of repeater that is being used. Non-limiting examples of different repeaters include an internal-use-only repeater that is A/C powered with battery backup, an internal-use-only repeater that is D/C battery powered, a weatherproof repeater that is A/C powered with battery backup, and a weatherproof repeater that is D/C battery powered.

A repeater **104** may also utilize a variety of internal hardware components, as shown in FIG. 3. With the exception of the A/C power transformer in the A/C power devices, the hardware configurations for different repeaters may all be the same. The repeater can house an 802.15.4 wireless transceiver **302** that meets both the size and power requirements of the device. The 802.15.4 transceiver **302** may be further integrated with an Ethernet connection, one or more 802.11 wireless Internet routers and one or more dial-up modems (not shown). In other embodiments, the repeater **104** may house any other type of wireless transceiver. Additionally, the repeater **104** can have an antenna, which may be customized or altered depending on whether or not the monitor is being used indoors or outdoors. Further, the repeater **104** may also have an ultra-low power 8-bit processor **304**, similar to the one described above with respect to the monitor and optionally having a hibernate mode. Additionally, the repeater **104** can utilize flash memory

containing the protocol stack as well as firmware developed to react to repeater events, a battery or batteries **306**, which may power the repeater for one year or longer and an A/C power transformer **308**, which can be utilized for locations with an electrical plug.

The repeater **104** may also have a software component designed to be small to limit the amount of processing power and thus extending the battery **306** life in the event that the device is not A/C powered. This software may be entirely programmed into the firmware. One part of the software may be the IEEE 802.15.4/ZigBee protocol stack, or any other appropriate wireless protocol stack, which can provide the ability for the repeater to wirelessly communicate with wearable monitors and gateways in the system. The repeater **104** can be designed as a routing node, allowing it to pass data along from source nodes to destination nodes. The repeater may also be considered a full function device (FFD) in terms of the IEEE 802.15.4 standard. The repeater **104** further may utilize any of a variety of batteries, for example type N or rechargeable batteries, to power it as it routes data or may alternatively be A/C powered. Finally, the software on the repeater **104** may also respond to beacons from a gateway device, which can request current status to be sent. The status data transmitted from the repeater **104** to a gateway device can include both status data of the repeater **104** itself as well as current status data of the wearer of the monitor **102**. If the repeater **104** is battery powered, additional processing may be performed that tests the battery power on a regular basis and sends a low battery alert when a predetermined amount of battery power in battery or batteries **306** is, for example 20%. Alternatively, a "low battery" alert may be transmitted at any predetermined amount at or below 50% of the remaining battery life.

An exemplary gateway device, as shown in FIG. 1, item **106**, is shown in greater detail in FIG. 4. The gateway device **106** can be a fixed-location device that bridges a 802.15.4 ZigBee wireless network, or any other alternative wireless network used by the above-described devices, with a local area network in a facility or home. A variety of wearable monitors **102** and repeaters **104** may operate through an individual gateway **106** and the gateway **106** may have similar functionality to an 802.11 wireless access point, or any other type of wireless access point. Similar to the repeater **104**, the gateway **106** may utilize a variety of hardware and software components. Additionally, the gateway **106** may have different configurations based on the local area network **108** that is configured in a facility or home. For example, a gateway **106** may be an A/C powered device with Ethernet network connectivity, an A/C powered device with 0.802.11b (or other) network connectivity, or an A/C powered device with modem connectivity.

In a further embodiment shown in FIG. 4, a gateway **106** may have a variety of hardware components. These components may include an 802.15.4 wireless transceiver **402**, or any other type of wireless transceiver, and an antenna, similar to those in the repeater **104**. The gateway **106** may also have a processor **404**, for example a 32-bit processor. Additionally, the gateway **106** can utilize flash memory **406**, or other memory type, which can store patient data as a temporary network buffer and contain the protocol stack as well as firmware message processing **408**. The gateway **106** can also have an amount of RAM that is needed for the application and an A/C power transformer **410** to provide power for the gateway, as well as an internal D/C battery backup.

The gateway **106** may also provide Internet connectivity. Connections to the Internet may be made by at least one of

an 802.11 wireless connection **412**, Ethernet connection **414**, modem **416**, cellular or mobile data service **418**, or any other device capable of connecting to the Internet.

The software used in the gateway **106** shown in FIG. **4** can be used in processing events from the wearable monitor and may optionally be Linux-based. Additionally, all of the software incorporated into the gateway may be programmed into the firmware. One such software component is an operating system, for example a Linux or Linux variant operating system **408**. Further, the gateway **106** can include an IEEE 802.15.4/ZigBee protocol stack, or any other type of wireless protocol stack, the combination of which can provide the ability for the gateway **106** to wirelessly communicate with wearable monitors **102** and repeaters **104** in the system **100**. The gateway **106** may further be designed as a routing node so that it can pass data along from source nodes to destination nodes. The gateway **106** may be considered a personal area network (PAN) coordinator node under the twins of the IEEE 802.15.4 or master node under IEEE 802.15.1 or other wireless standard. Additionally, if there are multiple gateways in the network for scalability, a single gateway may be chosen as the PAN coordinator and the remaining gateways can function as coordinators in a cluster tree network topology. The coordinator nodes can also generate beacons, for example status requests, that the other nodes in the network may respond to on a periodic basis. Additionally and optionally, PAN proxy functions can be supported in the gateway **106** or server **110** in software to reduce network traffic and data transmissions to improve and optimize network design.

Other software included in a gateway **106** can include a reliable queue, which can provide for scalability and reliability of the delivery of critical monitoring events to the server, as well as delivery of critical confirmations and messages from the server to monitors **102**. A gateway **106** can also have the capability to process the events sent to it by the wearable monitors **102** and the repeaters **104**. In situations where there may be multiple events from the same monitor **102** or repeater **104**, the gateway **106** can have the intelligence to collapse the events and perform a root cause analysis. Finally, gateways can receive software upgrades and updates. Further, gateways may be able to upgrade the wearable monitor and repeater components when new firmware is made available for updates.

In another embodiment, the system may be utilized in the home of a patient. A home-based system, however, may contain a gateway **106** having additional intelligence so that it also can have the decision making capabilities based on a patient's physiological trends and statistical data for instances where a patient can be provided immediate feedback for self awareness and patient education about their ailments. A home based system may also contain repeaters **104** serving as locating nodes and providing daily activity assessment data regarding the patient. The gateway device **106** may also be able to continue communication with a healthcare provider's server **110** so that a healthcare team can maintain their ability to monitor the patient. The communication between the system in the patient's home and the healthcare facility can be securely delivered through encryption to ensure patient privacy and, if necessary, to comply with the Health Insurance Portability and Accountability Act (HIPAA), The Health Information Technology for Economic and Clinical Health (HITECH) Act regulations and, if necessary, military specific requirements.

In an alternative embodiment shown in FIG. **5**, a mobile gateway **500** may be used in lieu of or with gateway **106**. The mobile gateway **500** functions similarly to gateway **106**,

insofar as it can have a wireless transceiver **502** and antenna, processor **504**, operating system **506** and flash memory **508**. A mobile gateway **500** can also bridge the ZigBee wireless network, or any other wireless network used with the system, with a cellular network **512** and allow for monitoring of the wearer of a monitor **102** when the monitor **102** is away from their home or facility. A mobile gateway **500** can also contain GPS locator **510** capabilities to identify the location of the wearer in case of an emergency event. Further, mobile gateway **500** may use rechargeable battery **514** or an A/C source to power the device. A mobile gateway **500** may be configured in a variety of manners, such as by partnering with a mobile phone manufacturer to integrate gateway capabilities into a ZigBee-enabled, or other wireless protocol-enabled, mobile phone or by integrating gateway cellular and GPS capabilities into a wearable monitor.

FIG. **6** shows a more detailed view of server **110**. The server **110** can process the logic associated with the monitoring system **100** and provide the capability to configure the user information and handle the processing of events from various users using statistical analysis engine **602**. Further, the server **110** can track and store the incidence of falls and other medical emergencies at the site using storage, database or databases, or memory **603** in conjunction with statistical analysis engine **602**. It can also have the ability to send targeted real-time medical alerts to caregivers and may optionally escalate these alerts to additional members of a healthcare team as well as track response times using alert notification **604**. These alerts may include email **606**, voice transmission **608**, SMS **610** or other alert transmission **612**. The server **110** may also provide statistics on the vital signs of a patient or patients as well as their location and, through the use of complex applications software, can make intelligent decisions based on trends in patient data and statistical data using tools disposed in statistical analysis engine **602**. Server **110** may include triage sorting capabilities **614**, allowing for improved organization of patient data. A presentation user interface **616** may also be used with server **110** so as to provide an accessible and easily navigable way of viewing data in server **110** and initiating messages that are intended for monitor **102**. The presentation user interface **616** may further be used by operating system and networking software **622** to provide additional methods of user access. Additionally, server **110** may have security perimeter **618**, which may prevent unauthorized access to data transmitted to the server. Network configuration data, privacy information and management data **620** may also be housed on server **110**. Finally, server **110** may also include patient data manager **624**, which may house any of a variety of data associated with any number of patients.

The server **110** may also include one or more databases **603**. Data stored in the one or more databases **603** can include accumulated patient information and system configuration information. This information can be used for a variety of purposes, such as supporting one or more remote monitors, one or gateways, one or more repeaters, and any other device that may be used in the system.

In one exemplary embodiment, at least one server may be used for deployment in support of a number of gateways, repeaters and monitors. The server, e.g. server **110**, and system architecture can be flexible and scalable, however, allowing the number of servers deployed will be determined, for example, by the unique requirements presented by institutional organization, the desire by the institution for local or remote maintenance support, physical and geographic distance, network reliability, desired separation of data among multiple institutions, processing capacity desired and any

other relevant needs or desires. Processing may be distributed across multiple specialized servers, which can allow, for example, certain portions of the database and complex software applications for statistics to be on one or more servers at one location, and certain portions of the database and complex software applications for communications and configuration with gateways and associated repeaters and monitors might be at another location or locations. Some deployments may include gateways, repeaters and monitors at one location but all of its supporting servers are at a different location.

The server **110** may include software bundles with rack-mounted server hardware included in operating system and networking software **622**. This can be, for example, a standard Intel-based processor and PC-like functionality. Further, the server **110** associated with a deployment can have a variety of application software built on top of open source software components. Other software components can include an operating system, such as Linux, a Linux variant, Windows or a Windows-based operating system. A web-based interface, such as presentation interface **616**, can also be provided via a web server, for example Apache http server. Further, an application server, such as Tomcat, can be used to dynamically monitor events and statistics and configure contact information notification services. A database may also be used to persist the configuration and data, such as patient information, contact data, and statistics. Because multiple patients, multiple monitors and multiple sensors may be included in the system, the configuration may have unique identifiers for each patient, as stored in patient data manager **624**. Additionally, a set of unique messages appropriate for each type of event and each type of data from a sensor may be used. Complex software applications, such as engine **602**, may utilize the data to create patient records, statistics, and analysis of data for reports. Complex software applications can also apply statistical techniques such as Bayesian Networks, moving averages, regression analysis, inference, probabilistic reasoning, and other analytical, machine learning, and artificial intelligence techniques known to a person having ordinary skill in the art to filter and apply data. Standard reports can be available on a per-event, per-patient, and per-facility basis, as well as any other desired basis. The ability to customize reports can be made available and the output from these reports could potentially also be used for billing or for quality control. Examples of open-source database projects that may be utilized are Apache projects such as Apache Derby, and MySQL or other databases known to a person having ordinary skill in the art.

The server **110** software may also include reliable queue, which can ensure scalability and reliability of the delivery of critical monitoring events to the caregiver mobile devices. Additionally, a notification service can provide the ability to communicate with mobile devices as well as the ability to send SMS text messages to pages and mobile phones as well as the sending of voice messages. The server **110** can further have the ability to process all of the events sent to it by the gateways in the facility or network and, additionally, the server **110** can have the ability to upgrade the gateway **106** as well as provide firmware to the gateway **106**, which, in turn, can upgrade the wearable monitor **102** and repeater **104** components when new firmware, if desired, is available. The server **110** can also perform proxy functions through software that may have capabilities of the gateway **106** that can be used to improve and optimize network performance and reduce data transmissions from the gateway **106**.

In another exemplary embodiment, server **110** may be able to identify specific sensor values and time stamps that

originate from a specific monitor, e.g. monitor **102**. This identification may be able to take place regardless of how the data from monitor **102** is transmitted or over which network path or paths the data is transmitted. For example, server **110** may identify data as being sourced from monitor **102** despite the data generated by monitor **102** having traveled over one or more of a wireless network, the Internet, a private local area network (LAN), wide area network (WAN), and a satellite or public carrier wired or wireless network. Additionally, server **110** may also account for data that may have been temporarily stored in monitor **102** when transmission was not available and later transmitted to server **110**. The data sent from an exemplary monitor may include a protocol of identification and unique or specific messages and formats for the exemplary monitor. The transmitted data may include information such as values generated by sensors disposed on the monitor, the time of a sensor value, information supportive of a message error detection and correction scheme and an encryption method to protect user privacy, which may exceed HIPAA and HITECH standards.

In another embodiment, server **110** may provide notification or report information on the wellness or health of a wearer of monitor **102**. Server **110** may provide this information by utilizing complex application software that compares incoming data from monitor **102** with previously stored data from monitor **102** and other monitors recording similar data. Additionally, patient responses to messages sent by server **110** and displayed on monitor **102** may provide additional feedback and automatic populating of longitudinal data in databases **603** for compilation by engine **602**. The comparison of the sum of the data can be used to generate predictive probabilistic statistics, for example probabilistic statistics derived from multivariate Bayesian inference networks, probabilistic relations with a deterministic predictive capability for impending events, and comparison to peers in population-based disease models. The data sourced from monitor **102** may be further be encrypted and server **110** may decrypt the data prior to processing and analyzing it. This data may also be correlated to generate notifications indicating changes in the health status of a wearer of monitor **102**. Additionally, server **110** may generate location data for monitor **102** based on the network interaction and signal attributes of monitor **102**, such as which devices monitor **102** is transmitting to and which network paths data generated by monitor **102** are being transmitted over.

FIG. 7 is a side view of an alternative monitor **700** that facilitates non-intrusively and more continuously detecting a user's heart beat and determining the user's heart rate. FIG. 8 is a bottom view of monitor **700**. In the exemplary embodiment, monitor **700** may be a watch worn by the user on the user's wrist. Alternatively, monitor **700** may be worn on any part of the user's body, such as, but not limited to, a finger, an ankle, a thigh, a bicep, the head, the neck or the abdomen. In another embodiment, monitor **700** may be any type of bracelet, anklet and/or other wearable accessory that enables monitor **700** to function as described herein.

In the exemplary embodiment, monitor **700** may include a casing **702** coupled to a band **704** wherein a plurality of internal components may be coupled within casing **702**. In one embodiment, monitor **700** may include a battery **706**, an antenna **708**, memory **710** and a wireless transceiver **712**, which are all coupled to a processor **714**. Wireless transceiver **712** facilitates communicating with server **110** and/or any other communication components of system **100**. Additionally, antenna **708** facilitates producing a significantly uniform signal having a significantly uniform strength ema-

nating in all directions. Antenna 708 may be further optimized for communication in an indoor environment. In one embodiment, processor 714 can be an ultra-low power 8-bit processor. Moreover, processor 714 may include a hibernate mode where only micro-amps of current are used to power the hibernating device, and which only “wakes up” or activates to sample data or process events, which can minimize power requirements and extend battery life. In one embodiment, memory 710 may contain the latest sensor data and alerts when monitor 700 is out of the range of a network, the protocol stack as well as firmware developed to react to events generated by the sensors.

In the exemplary embodiment, the term “processor” is not limited to just integrated circuits, but broadly refers to a microcontroller, a microcomputer, a programmable gate array, a programmable logic controller, an application specific integrated circuit and other programmable circuits. These aforementioned terms may be used interchangeably herein. As a result, processor 714 may be any type of processor known to a person having ordinary skill in the art that enables monitor 700 to function as described herein. In the exemplary embodiment, processor 714 may include a bus (not shown) or other communication mechanism for communicating information, wherein processor 714 may be coupled to the bus and facilitates processing the information. In one embodiment, a plurality of processors 714 may be arranged in a multi-processor arrangement to facilitate faster processing as compared to a single processor arrangement. In the exemplary embodiment, memory 710 may include flash memory, random access memory (RAM) or other dynamic storage device (e.g., dynamic RAM (DRAM), static RAM (SRAM) and synchronous DRAM (SDRAM)) coupled to the bus for storing information and instructions to be executed by processor 714. In addition, memory 710 may be used for storing temporary variables or other intermediate information during the execution of instructions by processor 714. Monitor 700 may further include a read only memory (ROM) or other static storage device (e.g., programmable ROM (PROM), erasable PROM (EPROM) and electrically erasable PROM (EEPROM)) coupled to the bus for storing static information and instructions for processor 714.

In addition, monitor 700 can include any of a variety of sensors such as, but not limited to, medical-grade sensors which can be employed to determine the health of the wearer. For example, the variety of sensors may include a temperature sensor (not shown) and an accelerometer 716 for the x-axis, the y-axis and the z-axis, as shown in FIG. 8 and as described in more detail below. Monitor 700 may also include a heart pulse sensor pair 718 coupled to band 704. In one embodiment, band 704 may include a plurality of sensor pairs 718 coupled thereto to form a sensor array 720. Sensor pairs 718 may be coupled to an inner surface 722 of band 704 such that when monitor 700 is coupled to the user, sensor array 720 is positioned adjacent the user’s skin, and more specifically an artery of the user. Each sensor pair 718 may include an emitter 724 and a detector 726. In the exemplary embodiment, emitter 724 may include a light source 728 such as a light emitting diode (LED), which facilitates emitting light, or an electromagnetic wave into the user’s body, as described in more detail below. Alternatively, light source 728 may be any type of light source known to a person having ordinary skill in the art that enables monitor 700 to function as described herein. Detector 726 facilitates detecting the light emitted into the user, which is reflected or refracted back from the user, as described in more detail below. In one embodiment, detector 726 may be a photo-

diode that causes varying amplitudes of current to flow in the circuit in correlation with the user’s blood flow. Alternatively, detector 726 may be any type of detector known to a person having ordinary skill in the art that enables monitor 700 to function as described herein.

Each sensor pair 718 may be positioned adjacent another sensor pair 718 coupled to band 704. Adjacent sensor pairs 718 may be oriented such that emitter 724 of a first sensor pair 718 is positioned opposite from detector 726 of a second sensor pair 718 and detector 726 of the first sensor pair 718 is positioned opposite from emitter 724 of the second sensor pair 718. As a result, each sensor pair 718 is oriented in a substantially opposite position with respect to each adjacent sensor pair 718.

FIG. 10 is a chart readout view of a signal 730 detected by detector 726, as described in more detail below. Signal 730 includes peak data points 732 that generally represent the user’s heart beats detected by detector 726. The x-axis of the chart represents time; therefore a distance equivalent to the distance between two adjacent peak points 732 generally represents the user’s heart beat interval time 734. In one embodiment, the user’s heart rate is directly calculated into beats per minute; the variation between beats per minute may then be calculated into heart rate variability in the time domain. A Fourier Transform or similar technique may also be applied to the variation between beats per minute in order to transform the variation between beats per minute into the frequency domain for spectral analysis. In another embodiment, external interference and/or factors may cause artifacts, or false-positive data points to develop in the signal. Artifacts may be information or peak points that do not represent the user’s heart beat but rather are caused by external factors. In one embodiment, external factors such as, but not limited to, overhead lights, fluorescent lights and the user’s motion may create artifacts in the received signal 730 which may render signal 730 unreadable and unstable. Artifacts in a signal add additional peak points to the signal which monitor 700 may mistakenly confuse as a heart pulse. In such an example, if monitor 700 treats an artifact as a heartbeat, monitor 700 may report incorrect vital information of the user to system 100. As a result, such artifacts should be reduced, eliminated, canceled out of the signal and/or ignored from signal 730 by monitor 700, as described in more detail below. In one embodiment, motional artifacts may be eliminated by taking a reading of the user’s heart rate when the user is substantially still. In another embodiment, interference artifacts may be reduced by filtering out the known frequencies of common interfering devices such as overhead lights. In yet another embodiment, motional artifacts may be cancelled out using accelerometer 716, as described in more detail below.

FIG. 11 is a logic flow diagram of heart rate code structure 736 for monitor 700, which enables monitor 700 to power on, detect, for example, peak points 732 within signal 730, filter signal 730 and send a filtered signal to a heart rate algorithm 738, which facilitates determining the heart rate of the user. FIG. 12 is a schematic view of monitor 700. FIG. 13 is a logic flow chart of heart rate algorithm 738, which facilitates detecting, for example, peak points 732 in signal 730, determining the user’s heart beat pulses and determining the user’s heart rate.

Sensor array 720 enables monitor 700 to automatically adjust to the many different physiologies of users that may wear monitor 700. As described below, processor 714 determines which sensor pair 718 may detect an acceptable signal

from the user. As a result, monitor 700 may be coupled to any type of wrist on any type of user and detect a heartbeat signal.

In the exemplary embodiment, monitor 700 may be coupled to the user's wrist such that sensor array 720 is positioned substantially adjacent to the underside of the user's wrist, and more specifically the user's artery. As described in more detail below, during operation, monitor 700 facilitates detecting a user's heart rate by emitting light into the skin of the user using emitter 724. The light penetrates the skin and is partially reflected or refracted back out of the Skin towards detector 726. When emitter 724 is positioned substantially near an artery of the user, the pulsing of blood through the artery may selectively filter the frequency of the reflected or refracted light, such that the reflected or refracted light substantially represents the pulsing of the blood and therefore the heart beats of the user. As a result, detector 726 may detect the frequency-density changes in the reflected or refracted light, which enables monitor 700 to detect the heart beats and the heart rate of the user, as described in more detail below.

During operation, heart rate algorithm 738 powers up monitor 700 at step 740. Next, in step 742, heart rate algorithm 738 waits for stabilization of readable signal 730, wherein processor 714 searches for a readable signal 730 using sensor array 720. Stabilization of a received signal occurs when a readable heart beat signal 730 is detected by detector 726 and the heart beat signal 730 is substantially free of artifacts. Alternatively, processor 714 may use sensor array 720 to search for an optimal signal. In searching for a readable signal, monitor 700 emits light using emitter 724, wherein the light is reflected or refracted back towards monitor 700 and detected using detector 726 of one of sensor pairs 718 as signal 730. Detector 726 may need to stabilize the bias control feedback loop prior to detecting reference peaks. In one embodiment, a level of feedback may be used by monitor 700 to properly bias detector 726, which enables detector 726 to better distinguish variations in signal 730. In such an embodiment, monitor 700 may have a set or previously programmed detector bias feedback value, which is read from memory 710 by processor 714 in step 744, shown in FIG. 11. Monitor 700 then controls the detector bias feedback at step 745, which adjusts the sensitivity of detector 726. Similarly, an intensity level, or power control, of light source 728 may be adjusted by monitor 700 to facilitate increasing the effectiveness of light source 728, as described in more detail below.

In the exemplary embodiment, sensor array 720 may be coupled in communication to an analog gain 746 that facilitates increasing the analog signal before the signal is converted to a digital signal. Analog gain 746 may be coupled, in series, to an analog filter 748, an analog/digital converter 750 and a digital filter 752. In one embodiment, analog filter 748 may be a low pass filter. Analog filter 748 may also be a filter having several stages, where the first stage is about 15 Hz the second stage is about 20 Hz, and the third stage is about 66 Hz. In one embodiment, digital filter 752 may be a band stop filter or a notch filter that facilitates filtering frequencies at about 60 Hz, at about 90 Hz and at about 120 Hz. As a result, analog filter 748 and digital filter 752 facilitate removing and/or reducing ambient interference from the detected signal 730.

Turning back to FIG. 10, once signal 730 is stabilized and read by monitor 700, in step 754 heart rate algorithm 738, and more specifically processor 714, facilitates determining a reference peak point 755, which represents a reference heartbeat of the user. The reference peak point 755 enables

monitor 700 to determine additional heart beats of the user, though other methods of setting a reference point may also be applicable. In one embodiment, reference peak point 755 may be one of a set of potential peak points 732 within signal 730 that passes specific qualifiers, or factors, such as but not limited to, amplitude, and may be the first to be observed in the sample. A peak point 732 that has an amplitude that falls within a certain range may be an acceptable reference peak point 755. In one embodiment, the amplitude range of peak points 732 may be measured in volts. In the event signal 730 is too weak and peak points 732 have too low an amplitude, monitor 700 may automatically adjust sensor pairs 718 to facilitate enhancing signal 730. Monitor 700 may also adjust sensor pairs 718 in the event signal 730 is too strong and peak points 732 have too high an amplitude. In the case of a weak signal, monitor 700 may automatically increase the intensity of emitter 724 to facilitate strengthening the amplitude of signal 730 received by detector 726. Moreover, monitor 700 may modify the detector bias feedback to strengthen the signal detected by detector 726 to facilitate making signal 730 more readable. Similarly, monitor 700 may decrease the intensity of emitter 724 to facilitate weakening the amplitude of peak points 732 to obtain a more readable signal 730. Moreover, monitor 700 may modify the detector bias feedback to weaken the signal sensitivity of detector 726 to facilitate making signal 730 more readable.

In the event the changing of the intensity of light source 728 or changing the detector bias feedback does not produce a readable signal, monitor 700 may deactivate the current sensor pair 718 and activate another sensor pair 718 of sensor array 720. Once the new sensor pair 718 is activated, monitor 700 restarts the algorithm at step 742 and waits for stabilization. As a result, monitor 700 may fit a variety of users that have wrists of differing circumference and shape. Furthermore, monitor 700 and more specifically sensor arrays 720 may allow users to adjust the position of the band on their body without the need for assistance from a third party to re-position monitor 700 and sensor array 720. Monitor 700 and specifically sensor array 720 may also self-align on the user's wrist, thereby facilitating obtaining an improved signal and facilitating obtaining a signal in the event of monitor 700 being moved or adjusted by the user. As such, monitor 700, and more specifically sensor array 720 enables monitor 700 to fit virtually all users. In the event no readable signal can be found using all the sensor pairs 718 of sensor array 720, monitor 700 may turn off at shutdown step 756.

Once an acceptable reference peak point 755 is detected, monitor 700 saves the parameters of reference peak point 755 into memory 710. In one embodiment, the parameters of reference peak point 755 may include, but not limited to, amplitude. Next, in step 760 monitor 700 searches for a subsequent, or second, peak point 761 that passes specific qualifiers, such as a substantially similar amplitude as reference peak point 755 and where second peak point 761 occurs within a specific time after reference peak point 755. In the event monitor 700 detects a second peak point 761 that passes the qualifiers, second peak point 761 is saved in memory 710 as a potential first heart beat peak point in step 762. Second peak point 761 is then used as a reference peak point to enable monitor 700 to detect a third peak point 764 that passes the qualifiers with respect to second peak point 761. If third peak point 764 does not pass the qualifiers with respect to second peak point 761, then monitor 700 goes back to step 754 to begin searching for a first reference peak point 755. In other words, if third peak point 764 does not have the substantially same amplitude as second peak point

761 and/or third peak point 764 does not occur within a predicted amount of time after second peak point 761, then second peak point 761 and/or third peak point 764 may be an artifact and monitor 700 goes back to step 754 to restart the reference point process.

In step 766, if third peak point 764 passes the qualifiers, monitor 700 saves the second and third peak points 761 and 764 as heart beats and determines the time between second and third peaks points 761 and 764 to facilitate determining a first heart rate value 768. Moreover, monitor 700 saves third peak point 764 as the new reference peak point and continues searching for a subsequent fourth peak point 770 and a fifth peak point 772. Similarly, if fourth peak point 770 passes the qualifiers with respect to third peak point 764, fourth peak point 770 is then saved into memory 710 and becomes the new reference peak point for fifth peak point 772. Moreover, processor 714 may then determine a second heart rate value 774, which may be the time between third peak point 764 and fourth peak point 770.

In step 776, once forth and fifth peak points 770 and 772 are found, monitor 700 determines the time between forth and fifth peak points 770 and 772 to facilitate calculating a third heart rate value 778, which is saved to memory 710. The first, second and third heart rate values 768, 774 and 778 are then averaged together to determine an average heart rate for the user. As monitor 700 determines new heart rate values, the older heart rate values are cleared out of the averaging formula. As a result, the user's average heart rate is continually updated and the user's heart rate variability is determined. Variation in heart rate may also be determined over various time spans and may utilize statistical calculations. Furthermore, variation in heart rate may be converted to the frequency domain via utilization of Fourier Transforms, and the results of the calculation may be sent to server 110.

In one embodiment, once monitor 700 determines the heart rate of the user after detecting four uninterrupted heart beats, monitor 700 may shutdown at step 780. Alternatively, monitor 700 may be programmed to continuously detect the user's heart rate. In yet another embodiment, monitor 700 may be programmed to monitor the user's heart rate for a specific amount of time before shutting down. In such an embodiment, monitor 700 may also be programmed to restart after a specific amount of time and detect the user's heart rate. In another embodiment, monitor 700 may be programmed to monitor the user's heart rate for any amount of time. Allowing such variation in sampling methods may facilitate extending battery life of monitor 700. In one embodiment, the sensor pair 718 that was used in the most recent successful measurement may be retained in memory such that it may be used first in the next sample session, thereby shortening detection time and extending battery life of monitor 700.

Monitor 700 may transmit the user's heart rate and heart rate variability to server 110 using wireless transceiver 712. In the event monitor 700 is out of range of server 110, or any of the other communication components of system 100, monitor 700 may save the heart rate information in memory 710. Such information may be uploaded to server 110 once communication between server 110 and monitor 700 is restored.

In the exemplary embodiment, monitor 700 facilitates detecting a heart rate of the user using an easy to use and adaptive watch. Monitor 700 may be attached to any user's wrist and processor 714 will begin to search for a readable signal 730. Each user may have different physiologies, skin thicknesses, and wrist thicknesses to which monitor 700, and

more specifically, sensor array 720 may adapt. In one embodiment, monitor 700 may be initially configured by a nurse or a technician to adjust, or customize the various settings on monitor 700 for the user and store those settings in memory 710. In such an embodiment, the various settings may be, but not limited to, the intensity level of light source 728, the detector bias feedback value of detector 726 and the particular sensor pair 718 that initially receives a readable signal 730. In the event monitor 700 shifts on the user's wrist or if the user removes monitor 700 and then reattaches monitor 700, monitor 700 may default to the custom settings in memory 710 to begin the search for signal 730, which facilitates reducing the time required to detect a readable signal thereby increasing the battery life of monitor 700. In the event monitor 700 has been substantially shifted on the wrist or reattached in a substantially different orientation than the initial orientation, monitor 700, and more specifically processor 714, may begin the stabilization process to find signal 730 as described above.

In another embodiment, monitor 700 may be initially attached by a user to their wrist, without the use of a nurse or technician to customize monitor 700. In such an embodiment, processor 700 may be programmed to initialize sensor array 720 and begin the stabilization process as described above. Monitor 700 may automatically adjust the settings of monitor 700, which may include but not limited to, the intensity of light source 728, the detector bias feedback value of detector 726 and the particular sensor pair 718. Once a readable signal 730 is found, monitor 700 may store the above-described settings into memory 710 to facilitate faster stabilization of signal 730 in the event monitor 700 is shifted on the user's wrist or removed and reattached in a substantially different orientation on the user's wrist, thereby facilitating quickly re-determining the user's heart rate after removal and reattachment.

FIG. 14 shows an alternative embodiment of monitor 700 that includes accelerometer 716 coupled thereto. In the exemplary embodiment, accelerometer 716 facilitates measuring the acceleration, or motion, of monitor 700 in the x-axis, the y-axis and the z-axis. In the exemplary embodiment, accelerometer 716 may be coupled to an adaptive filter 782, which may utilize the information gathered by accelerometer 716 to filter undesirable heart rate artifacts due to motion.

During operation, motion of monitor 700 may create motional noise 784, which may transfer to signal 730, such that monitor 700 may detect motional noise 784. Motional noise 784 may be transferred to signal 730 such that a motional peak point generated by motional noise 784, may be a function of the motion. As a result, a transfer function 786 may be applied to the motion to determine the value of the motional peak point detected in signal 730.

In one embodiment, accelerometer 716 may be used to cancel and/or ignore motion artifacts in signal 730 that are created by the user's movements. For example, the movement of a user's arm as the user moves about may create pressure fluctuations in the user's blood flow, which may affect the reflected or refracted light which affects signal 730 received by detector 726. In one embodiment, accelerometer 716 may be used to measure the movement of monitor 700 and the movement of the user's limb to which monitor 700 is attached. Accelerometer 716 facilitates sensing and recording the movements such as, but not limited to, spatial position, acceleration and velocity of monitor 700 and the user's arm. In step 788, as shown in FIG. 13, monitor 700, and more specifically processor 714, may then match recorded motions with any received signals received at the

substantially same time by detector 726. In the event a peak point is found that does not pass the qualifiers and the peak point was detected at substantially the same time as the recorded movement of monitor 700 by accelerometer 716, the peak point may be declared a motional artifact and thus ignored by processor 714. As a result, processor 714 may continue looking for a subsequent peak point without having to restart the heart rate algorithm 736, which facilitates reducing time and increasing battery life when monitor 700 determines the heart rate of the user.

In the exemplary embodiment, accelerometer 716 enables monitor 700 to detect the heart beats and determine the heart rate and heart rate variability of a user while the user is moving or walking. Motional artifacts, or changes in the user's blood flow due to the user's movement may be measured and ignored by heart rate algorithm 736. As a result, the user is more free to move about while monitor 700 monitors the user's heart rate. Moreover, accelerometer 716 reduces the need for monitor 700 to restart the stabilization process as described above, which facilitates increasing the battery life of monitor 700.

In another exemplary embodiment, transfer function 786 may adjust signal 730 in accordance with the amplitude and direction of the vector of motion. Adaptive filter 782 may also automatically approximate an unknown transfer function 786 and remove motion artifacts from signal 730. Consequently, the number of acceptable signals for the heart rate and heart rate variability algorithm may be increased, and the need for monitor 700 to continue sampling or to restart the sampling process may be reduced. This may also facilitate extending the battery life of monitor 700.

In another exemplary embodiment, monitor 700 can facilitate detection of falls by the user. FIG. 15 shows an exemplary arrangement of a wireless device 1502, which can be a monitor such as monitor 700, and an external monitoring device 1504, which can be a server such as server 110. An algorithm can make use of accelerometer 716 to detect the movements of monitor 700 and indicate to server 110 that the user of monitor 700 has fallen in the following manner, for example. Similarly, FIG. 16 shows an exemplary embodiment of a method of detecting a fall 1600 via steps 1602-1614.

Accelerometer 716 can be used to determine which axis points most closely to the center of the earth by determining which axis reads closest to 1 G, within a threshold. When the user of monitor 700 begins to fall, there can be acceleration in some direction. When that acceleration exceeds a threshold, for example about 2 G, it can be noted, and microcontroller 714 can begin requesting accelerometer data 1506 at a predetermined time interval, for example about 8 ms. When the user contacts the ground, monitor 700 can be subjected to deceleration. When that deceleration exceeds a threshold, for example about -2 G, it can be noted. Once the user has finished falling, the axis that read about 1 G before the fall can read about 1 G again. If an axis that reads about 1 G experiences an acceleration and deceleration, passing through 0 more than once within a time threshold, a potential fall event can be indicated, and monitor 700 can submit data concerning the potential fall event to sever 110.

Server 110 can display data regarding potential fall events to users, who can validate the potential fall event by confirming that it represents a genuine fall. If the potential fall event does not represent a genuine fall, the user can adjust the values of configurable parameters 1508 used by monitor 700 to determine a potential fall event. These parameters 1508 can include an acceptable magnitude of acceleration in any direction which can start execution of the algorithm; an

acceptable duration of acceleration in any direction which can start execution of the algorithm; an acceptable magnitude of acceleration as a starting point for the axis in question; an acceptable magnitude of acceleration on the other side of 0 in order to continue fall consideration; an acceptable magnitude of acceleration once it has returned to the original side of zero in order to indicate a potential fall event; an acceptable amount of time to go from a peak magnitude on the original side of the zero axis to a peak magnitude on the other side of zero; or an acceptable amount of time to return from the peak magnitude on the other side of zero to a minimum magnitude required for fall recognition on the original side of zero. These parameters can be modified in such a way that the number of false positive indicated potential fall events are reduced. In this way, for example, a general set of parameters can be adjusted so to better suit the behavior characteristics of an individual user.

In an alternative exemplary embodiment, server 110 can tune the algorithm itself, for example automatically. If a user indicates which potential fall events represent genuine falls and which do not, server 110 can analyze, among other things, the frequency and characteristics of the false positives indicated in the impact data 1506 and modify the parameters 1508 to reduce the number of improper potential fall event indications. In this way, for example, a general set of parameters can be adjusted so to better suit the behavior characteristics of an individual user.

In an alternative exemplary embodiment, server 110 can solicit observations from caregivers, using its display, alternative displays and messages to mobile devices, concerning the conditions and nature of the fall that allows it to classify falls events and through this additional data input better correlate the observed fall characteristics with the parameters used for the alert event and modify parameters to reduce the number of improper fall event indicators.

In an alternative exemplary embodiment, collected falls data used in multi-variable algorithms in server 110 may correlate falls event data with the location data of the events, with sensor 112 ambient light levels data for the same location at the same time, and automatically identify a profile from the falls event data of high fall risk location due to poor visibility caused by low light levels.

Referring generally to FIGS. 17-21, other exemplary embodiments of the invention may be shown. The server 110 may maintain one or more patient-specific wellness indicators. A wellness indicator may be a real-time metric that characterizes some aspect of a patient's health and wellness. There may be multiple indicators that reflect different aspects of wellness (e.g., activity, sleep, physiological measurements such as blood pressure and oxygen saturation, gait stability, self-reported wellness). The source data for derivation of wellness indicators may include data entered by users of the system, data collected from sensors on a sensing device and returned to server 110, data and events resulting from processing on monitor 102, historical data stored on server 110, and data resulting from complex analysis and predictive models. A sensing device may be a monitor 102 or an external sensor 112.

Multiple simple wellness indicators may be combined into composite wellness indicators. Composite wellness indicators may be combined with other wellness indicators such that wellness indicators form a hierarchy. For example, the following list exemplifies individual wellness indicators A. for Activity and sleep, B. for Physiological Measurements, C. for Stability of gait, D. for Self-Assessment by survey, and E. for Activities of Daily Living, which may be weighted uniquely for the risk factors of an individual

patient and mathematically combined into a Total Wellness indicator, composite index and or set of indices:

Total Wellness

- A. Activity
 - a. Daytime
 - b. Nighttime
- B. Physiological
 - a. Blood Pressure
 - b. Weight
 - c. Glucose
 - d. Heart Rate
 - e. Oxygen Saturation Level
- C. Stability
 - a. Impacts
 - b. Falls
 - c. Stability Measure
- D. Self-Assessment
 - a. Depression
 - b. HF Symptoms
 - c. Activity Level
- E. Activities of Daily Living
 - a. Bathing
 - b. Toileting

Individual wellness indicators such as Physiological measurements may include several inputs such as blood pressure, heart rate, body weight, etc and these components may be weighted in accordance with an individual care plan or chronic disease risk profile. Furthermore, when individual wellness indicators are combined, the different aspects of the composite may be given different weightings. The system may be configured with different default weights for the various components of an indicator. The server may have an interface that enables caregivers to change the weightings for a particular patient when appropriate. A patient's settings and weightings might be pre-set based on the population-based risk indicators in managing a specific disease such as CHF, and may be presented on the server display as a set of pre-set choices or population-based starting points for clinicians, and then quickly personalized to the goals and risk factors for the particular patient, e.g. weight, blood pressure and heart rate.

An exemplary wellness indicator scale could be a range of numbers from 0 to 100, where 100 correlates to the patient being "perfectly well" in that particular factor. Patients lose points for any aspect of their wellness that deviates from a standard ideal. The specific point deductions are tied to the definition of the wellness indicator involved (e.g., in a sleep wellness indicator, the patient might lose 10 points for each instance of unrest in a specific sleep cycle). The system provides an interface that allows wellness goals to be set. For example, if a care plan calls for a patient to lose weight, a reduction in weight toward the goal would gain points on the indicator and an increase in weight would lose points on the indicator.

The server may be configured with a patient-specific normal range, a so called "target range" for each type of data that captures the expected values for the patient during different time periods (e.g., daytime, nighttime). If the patient data falls outside of this range, the patient might lose or gain wellness points. The server may also maintain a patient-specific baseline value for each type of data. If the patient deviates from this baseline, the patient would lose or gain wellness points. It is envisioned that the server could compare data values to population norms calculated from data stored in the system database or externally defined population norms entered via a server user interface. The population norms could be defined for the general popula-

tion or a certain subset of the population such as those over 70, those living in a particular facility, or those suffering from diabetes. An individual patient's deviation from these norms could also cause the patient to lose or gain wellness points.

Trends in wellness indicators and scores may be displayed in "dashboard" form on server 110 display or on a variety of remote display devices so that the indicators can provide caregivers with an "at a glance" view of how a patient is doing, for example as shown in FIG. 20. The dashboard view may also present additional context information that aids in the interpretation of the wellness indicators including normal ranges, baseline information, and population norms. The dashboard provides a novel and friendly way for patients and family caregivers to interpret complex data as being on target for the goals of the care plan. The Wellness Indicators graphical presentation, as they are updated at regular intervals, may provide patients and their immediate family a better understanding of their wellness, and provide education and incentives to improve the scores. The simplicity of following changes in the indicator, which are tied to key measured factors defined by clinicians, allows family members to help encourage the patient to improve adherence to their care plan. It also provides the basis for self-driven goal seeking and "keeping score" in incentives programs designed to encourage adherence. Aligning incentives of the patient and the clinician are important for successful chronic disease management.

The server may have an interface that allows staff to set the personal goals and weightings of a care plan or post-acute discharge plan and an interface that enables caregivers to follow the trends between checkpoints. Almost continuous automated monitoring, a nonintrusive electronic hovering over the patient between formal clinic office checkpoints, can be achieved with such a system. The simplicity of following changes in the indicator, which are tied to key measured factors defined by clinicians, allows family members to help encourage the patient to improve adherence to their care plan. It also provides the basis for self-driven goal seeking and "keeping score" in incentives programs designed to encourage adherence. Aligning incentives of the patient and the clinician are important for successful chronic disease management.

The system or server can also be configured to send real-time alerts to caregivers based on the value of wellness indicators (e.g., when the actual wellness indicator falls outside of the specified normal range or the indicator deviates by more than a specified amount from its baseline value).

The system or server may use data from multiple sensors attached to the wearable monitor to maintain wellness indicators. These may include an accelerometer used to detect patient motion in the x, y, and z axis, and a variety of physiologic sensors (e.g., skin temperature, GSR, elevation, heart rate, pulse ox, and the like).

The system or server may use data from one or more external sensors 112 that are not worn by the patient but provide additional environmental data related to the patient and the patient's behaviors to maintain wellness indicators. These may include location data, humidity sensor, toilet flush sensor, room motion sensor, door opening sensor, room temperature sensor, room ambient light sensor, and similar sensors that provide correlative data for deriving wellness indicators.

Wellness indicators may depend on an accurate temporal measure of activity level. To recognize a patient's real-time activity level, the monitor samples the accelerometer on a

configurable basis every “A” seconds. When each sample of acceleration values is gathered, the differences between the current sample and the previous sample on each axis are calculated, added together, and added to an overall sum for that period of time measured in seconds.

$$\text{Overall sum} = \text{Previous overall sum} + |x(t) - x(t-1)| + |y(t) - y(t-1)| + |z(t) - z(t-1)| \quad [t = \text{the currently sampled time, and } (t-1) \text{ is the previously sampled time}]$$

Once every “B” seconds, where B is the nap time or time between sensor payload transmissions by the wearable monitor **102**, for example 60 seconds, the overall sum is sent to the server in real time where the continuous time-series data can be accumulated in a relational database. After transmission, the overall sum value is reset to 0. If transmission in real time is not possible (i.e., when a wireless network is not available due to interference, unfavorable location, the patient is away from a residence or commercial wireless network, etc.), activity data values are stored in the watch monitor **102** and transferred when a connection is restored. In one exemplary embodiment, watch monitor **102** may hold 116 hours or more of data.

The system or server may include a sleep wellness indicator that can be used to track and detect changes in sleeping behavior. For example, as shown in FIG. **19**, the system may produce a sleep wellness indicator by recognizing sleep patterns by analyzing patient activity levels over many days or months or by comparing against known activity signatures that are indicative of various stages of sleep.

External sensors **112** may be attached to environmental fixtures to provide measurement of, and to transmit to gateway **106** with storage and processing capabilities **120**, and or to server **110**, those attributes such as temperature, humidity, detected motion, water level, and door openings, among other attributes.

The system may include a showering wellness indicator that can be used to track and detect changes in a patient’s showering behavior. The server could generate the showering wellness indicator using humidity levels, collected from an external sensor **112**, a humidity sensor, located in the bathroom, which are returned to the server for processing. For example, FIG. **17** may show a graph of a showering wellness indicator.

The system may include external sensors **112** installed in the bathroom such as the humidity sensor, a toilet flush sensor, a cabinet door sensor, or a motion sensor. The external sensors **112** may communicate with server **110** in the same manner as do other monitors **102**.

The system may also include a toileting wellness indicator that can be used to track and detect changes in a patient’s toileting behavior. For example, as shown in FIG. **18**, the system could produce the toileting wellness indicator by analyzing patient activity levels and comparing against known activity signatures that are indicative of toilet usage or by gathering data from a toilet flush sensor **112** installed in the bathroom. A change in toileting patterns is an important indicator identifying a variety of conditions such as stomach flu, urinary tract infection (a major risk factor for falls in the elderly), diabetes, prostate conditions, or other conditions as would be understood by a person of ordinary skill in the art.

The activity data derived from the accelerometer may be manipulated by algorithms in the system to derive values of physical exertion and energy expended, that correlate with standardized measurements of metabolic processes, physical exertion and energy expended.

The system may also include a gait stability wellness indicator which could analyze the number of falls, near-falls, or impacts experienced by an individual patient each day and over time as reported by monitor **102** used in wearable form. It might also include data derived from acceleration data gathered from the watch monitor while the patient was walking, which when analyzed could indicate that patient’s fall risk has increased.

The system may provide an interface that enables caregivers to classify fall data by outcomes, for example a fall, a near-fall due to obstruction, or a near-fall due to instability, to further refine the indicators and underlying causes. Such classification can be used to improve the automated assessment over time. The system may also maintain a patient-specific sensitivity setting used to distinguish falls from non-falls. The system can provide an interface for surveys, questionnaires, or other data gathering techniques to collect information related to activity level and fall risk and use that information to calibrate the patient’s sensitivity setting. Through this interface, the caregiver can also manually adjust the sensitivity setting of monitor **102** based on observed behaviors and activity.

A self-assessment wellness indicator may also be available to track an individual patient’s own opinion of their well-being or condition. The data may be gathered through use of a web-driven survey available to the user via an electronic tablet or personal communication device. The type of assessment could be specific to the individual patient and may be composed of different parts. Topics which may be surveyed might include depression, activity level, or symptoms specific to a particular condition, including psychological factors.

It is anticipated that these and other data pattern signature-based techniques can be used to identify and track other patient wellness-related parameters. Specifically, the data signature of a particular risk factor can be identified and an associated wellness indicator can be defined based on desirable goals and tracked to detect deviations from the goal. Examples are patterns of seizure events, reoccurring UTIs, bipolar epochs versus changes in sleep/awake ratios, emerging tremor patterns, etc. It is anticipated that such signatures are not limited to the data types mentioned here and could be defined for any other real-time data available to the system.

In an alternative exemplary embodiment, server **110** can tune the wellness indicators, for example automatically or based on user feedback. If a user indicates or marks which potential wellness indicator inputs or values represent an accurate portrayal of a patient’s baselines or trends and which do not (such as, for example, temporary or invalid data is input), server **110** can analyze, among other things, the frequency and characteristics of the incorrect wellness indicators indicated from the data input and modify or recalculate the wellness indicator values to reduce or eliminate improper values. In this way, for example, a general set of parameters can be adjusted so to better suit the health status characteristics of an individual patient.

The foregoing description and accompanying figures illustrate the principles, preferred embodiments and modes of operation of the invention. However, the invention should not be construed as being limited to the particular embodiments discussed above. Additional variations of the embodiments discussed above will be appreciated by those skilled in the art.

Therefore, the above-described embodiments should be regarded as illustrative rather than restrictive. Accordingly, it should be appreciated that variations to those embodi-

ments can be made by those skilled in the art without departing from the scope of the invention as defined by the following claims.

What is claimed is:

1. A method for health and wellness assessment comprising:
 - gathering wellness indicator inputs for patient-specific wellness indicators utilizing human observations, utilizing one or more sensing devices, or by utilizing a combination of human observations and one or more sensing devices;
 - transmitting wellness indicator inputs to a server through manual user input or transmission from a sensing device;
 - maintaining data for one or more patient-specific wellness indicators on the server;
 - deriving one or more wellness indicator values from one or more wellness indicator inputs;
 - providing an output or display of derived wellness indicator values for evaluation;
 - evaluating wellness indicator values to assess patient health;
 - receiving an input manually correcting wellness indicator inputs and recalculating values to improve accuracy of wellness indicator scores;
 - generating a correction value based on a frequency and a characteristic of the manually corrected wellness indicator inputs; and
 - automatically correcting a subsequent wellness indicator input based on the generated correction value.
2. The method of claim 1, wherein:
 - a wellness indicator can be a simple wellness indicator with a value that is derived directly from wellness indicator input or a composite wellness indicator that is derived from at least one other wellness indicator.
3. The method of claim 2, further comprising:
 - establishing formulas for weighting components of an individual wellness indicator or a composite wellness indicator and deriving the value of an individual or composite wellness indicator by applying the weighting to the corresponding values of its component wellness indicators.
4. The method of claim 3, further comprising:
 - comparing wellness indicator values to important contextual information such as population-based risk, population norms, or a patient-specific goal or normal range.
5. The method of claim 1, further comprising:
 - comparing wellness indicator values to prior values for that patient and allowing comparison and evaluation of patient-specific wellness indicator data over time.
6. The method of claim 1, further comprising:
 - displaying individual and composite wellness indicators in a novel graphical manner in which a scale of color and numbers provide a simple but unambiguous presentation of the wellness indicator values relative to the desired contextual values.
7. The method of claim 1, further comprising:
 - providing one or more sensors, including at least one of an accelerometer, a humidity sensor, skin temperature, weight sensors, GSR sensor, elevation sensor, and or physiological sensors;
 - incorporating these sensors in sensing devices, including at least one of a wearable monitor or external sensor;
 - measuring wellness indicator inputs at desired intervals automatically or manually; and
 - transmitting the results to the server.

8. The method of claim 7, wherein: external sensor includes at least one of, a humidity monitor, shower monitor, toilet flushing monitor, temperature monitor, light level monitor, door monitor, motion monitor, bed monitor, a bed, chair or sofa mounted weight monitoring sensor, and or other locational monitors.

9. The method of claim 1, further comprising: comparing wellness indicator values to patient-specific personalized baselines and patterns.

10. The method of claim 1, further comprising: providing an ability for certain wellness indicator values to trigger an alert.

11. The method of claim 1, further comprising: wellness indicator input comprising a survey that tracks an individual patient's own opinion of their well-being or condition.

12. The method of claim 1, further comprising: providing an ability to further engage the patient with the wellness indicators displayed and organized in a motivational challenge or game with incentives or rewards for the patient achieving patient-specific goals.

13. A system comprising:

circuitry configured to

gather wellness indicator inputs for patient-specific wellness indicators utilizing human observations, utilizing one or more sensing devices, or by utilizing a combination of human observations and one or more sensing devices;

receive wellness indicator inputs through manual user input or transmission from a sensing device;

maintain data for one or more patient-specific wellness indicators;

derive one or more wellness indicator values from one or more wellness indicator inputs;

provide an output or display of derived wellness indicator values for evaluation;

evaluate wellness indicator values to assess patient health;

receive an input manually correcting wellness indicator inputs to recalculate values to improve accuracy of wellness indicator scores;

generate a correction value based on a frequency and a characteristic of the manually corrected wellness indicator inputs; and

automatically correct a subsequent wellness indicator input based on the generated correction value.

14. The system of claim 13, wherein:

a wellness indicator can be a simple wellness indicator with a value that is derived directly from wellness indicator input or a composite wellness indicator that is derived from at least one other wellness indicator.

15. The system of claim 14, wherein:

the circuitry is configured to apply formulas for weighting components of an individual wellness indicator or a composite wellness indicator and derive the value of an individual or composite wellness indicator by applying the weighting to the corresponding values of its component wellness indicators.

16. The system of claim 15, wherein:

the circuitry is configured to compare wellness indicator values to contextual information such as population-based risk, population norms, or a patient-specific goal or normal range.

17. The system of claim 13, wherein:

the circuitry is configured to compare wellness indicator values to prior values for that patient to evaluate patient-specific wellness indicator data over time.

31

18. The system of claim 13, wherein the circuitry is configured to generate display data including individual and composite wellness indicators in a graphical manner in which a scale of color and numbers provide a simple but unambiguous presentation of the wellness indicator values relative to the desired contextual values.

19. The system of claim 13, wherein the circuitry is configured to compare wellness indicator values to patient-specific personalized baselines and patterns.

20. A non-transitory computer-readable medium including computer program instructions, which when executed by an information processing system, cause the information processing system to:

gather wellness indicator inputs for patient-specific wellness indicators utilizing human observations, utilizing one or more sensing devices, or by utilizing a combination of human observations and one or more sensing devices;

32

receive wellness indicator inputs through manual user input or transmission from a sensing device; maintain data for one or more patient-specific wellness indicators;

derive one or more wellness indicator values from one or more wellness indicator inputs;

provide an output or display of derived wellness indicator values for evaluation;

evaluate wellness indicator values to assess patient health; receive an input manually correcting wellness indicator inputs to recalculate values to improve accuracy of wellness indicator scores;

generate a correction value based on a frequency and a characteristic of the manually corrected wellness indicator inputs; and

automatically correct a subsequent wellness indicator input based on the generated correction value.

* * * * *

专利名称(译)	移动无线可定制的健康和状态监视器		
公开(公告)号	US9526421	公开(公告)日	2016-12-27
申请号	US14/089324	申请日	2013-11-25
[标]申请(专利权)人(译)	AFRAME DIGITAL		
申请(专利权)人(译)	AFRAME数字, INC.		
当前申请(专利权)人(译)	VRN健康有限公司		
[标]发明人	PAPADOPOULOS AMY CRUMP CINDY A WILSON BRUCE G		
发明人	PAPADOPOULOS, AMY CRUMP, CINDY A. WILSON, BRUCE G.		
IPC分类号	A61B5/00 G06F19/00 G08B21/04 A61B5/024 A61B5/11 A61B5/1455		
CPC分类号	A61B5/0022 A61B5/02427 A61B5/1117 G06F19/3418 G06F19/3475 G06F19/3481 G08B21/0446 G08B21/0453 G08B21/0423 A61B5/1112 A61B5/14551 A61B5/681 A61B5/721 A61B2562/0219 A61B2562/0233 A61B2562/046 G16H20/70 G16H40/63 A61B5/0004 A61B5/117 A61B5/14507 A61B5/ /14532 A61B2562/04		
优先权	60/660342 2005-03-11 US		
其他公开文献	US20140155705A1		
外部链接	Espacenet USPTO		

摘要(译)

提供了一种使用一个或多个健康指示器输入和值进行健康监测的方法和系统。可以提供一个或多个健康指示器监测设备用于测量健康指示器输入。健康指示器监测设备可以具有一个或多个传感器和与一个或多个传感器通信的微控制器。一个或多个服务器可以通过网络与一个或多个健康指示器监测设备通信。处理器可以被配置为操纵健康指示器输入，并且一个或多个输出设备可以基于健康指示符值创建期望的输出。

