



US009024582B2

(12) **United States Patent**
Penner et al.

(10) **Patent No.:** **US 9,024,582 B2**
(45) **Date of Patent:** ***May 5, 2015**

(54) **METHODS AND SYSTEMS FOR RECHARGING AN IMPLANTED DEVICE BY DELIVERING A SECTION OF A CHARGING DEVICE ADJACENT THE IMPLANTED DEVICE WITHIN A BODY**

(52) **U.S. CL.**
CPC *A61B 5/0215* (2013.01); *A61B 5/0031* (2013.01); *A61B 5/01* (2013.01); *A61B 5/026* (2013.01); *A61N 1/37217* (2013.01); *A61N 1/3787* (2013.01)

(71) Applicant: **Cardiac Pacemakers, Inc.**, St. Paul, MN (US)

(58) **Field of Classification Search**
USPC 320/107, 108, 112, 114, 115
See application file for complete search history.

(72) Inventors: **Abraham Penner**, Tel-Aviv (IL); **Eyal Doron**, Caesarea (IL); **Jeffrey E. Stahmann**, Ramsey, MN (US); **Keith R. Maile**, New Brighton, MN (US); **Binh C. Tran**, Minneapolis, MN (US); **Wangcai Liao**, Houston, TX (US); **Bin Mi**, Plymouth, MN (US); **Paul Huelskamp**, St. Paul, MN (US)

(56) **References Cited**

U.S. PATENT DOCUMENTS

2,463,533 A 3/1949 Harrison
2,786,899 A 3/1957 Carlisle et al.

(Continued)

FOREIGN PATENT DOCUMENTS

EP 0 499 939 8/1992
EP 0 928 598 12/1998

(Continued)

OTHER PUBLICATIONS

U.S. Appl. No. 12/427,312, Non-Final Office Action dated Dec. 4, 2013, 14 pages.

(Continued)

Primary Examiner — Edward Tso

(74) *Attorney, Agent, or Firm* — Faegre Baker Daniels LLP

(73) Assignee: **Cardiac Pacemakers, Inc.**, St. Paul, MN (US)

(*) Notice: Subject to any disclaimer, the term of this patent is extended or adjusted under 35 U.S.C. 154(b) by 0 days.

This patent is subject to a terminal disclaimer.

(21) Appl. No.: **14/088,425**

(22) Filed: **Nov. 24, 2013**

(65) **Prior Publication Data**

US 2014/0073972 A1 Mar. 13, 2014

Related U.S. Application Data

(63) Continuation of application No. 12/605,579, filed on Oct. 26, 2009, now Pat. No. 8,593,107.

(60) Provisional application No. 61/108,635, filed on Oct. 27, 2008.

(51) **Int. Cl.**
A61B 5/0215 (2006.01)
A61N 1/378 (2006.01)

(Continued)

(57) **ABSTRACT**

Methods, systems, and apparatus for recharging medical devices implanted within the body are disclosed. An illustrative rechargeable system includes a charging device that includes an elongate shaft having a proximal section and a distal section. The distal section is configured to be delivered to a location within the body adjacent to the implanted medical device. The charging device includes a charging element configured to transmit charging energy to a receiver of the implanted medical device.

20 Claims, 12 Drawing Sheets

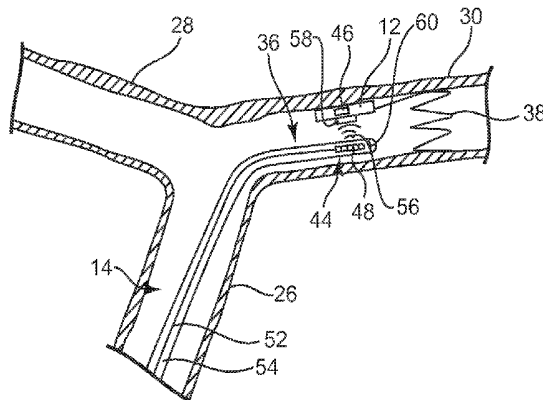

(51)	Int. Cl.		5,704,366 A	1/1998	Tacklind et al.
	<i>A61B 5/00</i>	(2006.01)	5,712,917 A	1/1998	Offutt
	<i>A61B 5/01</i>	(2006.01)	5,721,886 A	2/1998	Miller
	<i>A61B 5/026</i>	(2006.01)	5,724,985 A	3/1998	Snell et al.
	<i>A61N 1/372</i>	(2006.01)	5,733,249 A	3/1998	Katzin et al.
			5,743,267 A	4/1998	Nikolic et al.
			5,749,909 A	5/1998	Schroepfel et al.
			5,757,104 A	5/1998	Getman et al.
(56)	References Cited		5,759,199 A	6/1998	Snell et al.
	U.S. PATENT DOCUMENTS		5,776,168 A	7/1998	Gunderson
			5,800,478 A	9/1998	Chen et al.
			5,807,258 A	9/1998	Cimochowski et al.
			5,814,089 A	9/1998	Stokes et al.
			5,833,603 A	11/1998	Kovacs et al.
			5,861,018 A	1/1999	Feierbach
			5,876,353 A	3/1999	Riff
			5,891,180 A	4/1999	Greeninger et al.
			5,904,708 A	5/1999	Goedeke
			5,925,001 A	7/1999	Hoyt et al.
			5,935,078 A	8/1999	Feierbach
			5,957,861 A	9/1999	Combs et al.
			5,967,989 A	10/1999	Cimochowski et al.
			6,015,387 A	1/2000	Schwartz et al.
			6,030,374 A	2/2000	McDaniel
			6,070,103 A	5/2000	Ogden
			6,140,740 A	10/2000	Porat et al.
			6,141,588 A	10/2000	Cox et al.
			6,162,238 A	12/2000	Kaplan et al.
			6,164,284 A	12/2000	Schulman et al.
			6,167,303 A	12/2000	Thompson
			6,170,488 B1	1/2001	Spillman, Jr. et al.
			6,176,840 B1	1/2001	Nishimura et al.
			6,183,426 B1	2/2001	Akisada et al.
			6,185,452 B1	2/2001	Schulman et al.
			6,185,454 B1	2/2001	Thompson
			6,185,460 B1	2/2001	Thompson
			6,198,963 B1	3/2001	Haim et al.
			6,198,965 B1	3/2001	Penner et al.
			6,198,971 B1	3/2001	Leysieffer
			6,200,265 B1	3/2001	Walsh et al.
			6,236,889 B1	5/2001	Soykan et al.
			6,237,398 B1	5/2001	Porat et al.
			6,248,080 B1	6/2001	Miesel et al.
			6,259,951 B1	7/2001	Kuzma et al.
			6,260,152 B1	7/2001	Cole et al.
			6,261,249 B1	7/2001	Tallish et al.
			6,277,078 B1	8/2001	Porat et al.
			6,315,721 B2	11/2001	Schulman et al.
			6,427,088 B1	7/2002	Bowman et al.
			6,431,175 B1	8/2002	Penner et al.
			6,432,050 B1	8/2002	Porat et al.
			6,442,413 B1	8/2002	Silver
			6,442,433 B1	8/2002	Linberg
			6,472,991 B1	10/2002	Schulman et al.
			6,473,638 B2	10/2002	Ferek-Petric
			6,564,807 B1	5/2003	Schulman et al.
			6,577,899 B2	6/2003	Lebel et al.
			6,584,352 B2	6/2003	Combs et al.
			6,607,485 B2	8/2003	Bardy
			6,628,989 B1	9/2003	Penner et al.
			6,644,322 B2	11/2003	Webb
			6,664,763 B2	12/2003	Echarri et al.
			6,671,552 B2	12/2003	Merritt et al.
			6,676,601 B1	1/2004	Lacoste et al.
			6,689,091 B2	2/2004	Bui et al.
			6,712,772 B2	3/2004	Cohen et al.
			6,731,976 B2	5/2004	Penn et al.
			6,735,532 B2	5/2004	Freed et al.
			6,754,538 B2	6/2004	Linberg
			6,764,446 B2	7/2004	Wolinsky et al.
			6,788,973 B2	9/2004	Davis et al.
			6,790,187 B2	9/2004	Thompson et al.
			6,799,280 B1	9/2004	Edenfield et al.
			6,804,557 B1	10/2004	Kroll
			6,826,430 B2	11/2004	Faltys et al.
			6,855,115 B2	2/2005	Fonseca et al.
			6,873,869 B2	3/2005	Fischer
			6,960,801 B2	11/2005	Lung
			6,970,037 B2	11/2005	Sakhuja et al.

(56)

References Cited

U.S. PATENT DOCUMENTS

6,978,181	B1	12/2005	Snell
6,985,088	B2	1/2006	Goetz et al.
6,985,773	B2	1/2006	Von Arx et al.
6,988,215	B2	1/2006	Splett et al.
6,993,393	B2	1/2006	Von Arx et al.
7,003,349	B1	2/2006	Andersson et al.
7,013,178	B2	3/2006	Reinke et al.
7,024,248	B2	4/2006	Penner et al.
7,027,871	B2	4/2006	Burnes et al.
7,027,872	B2	4/2006	Thompson
7,035,684	B2	4/2006	Lee
7,060,030	B2	6/2006	Von Arx et al.
7,061,381	B2	6/2006	Forcier et al.
7,082,334	B2	7/2006	Boute et al.
7,096,068	B2	8/2006	Mass et al.
7,123,964	B2	10/2006	Betzold et al.
7,198,603	B2	4/2007	Penner et al.
7,203,551	B2	4/2007	Houben et al.
7,209,790	B2	4/2007	Thompson et al.
7,212,133	B2	5/2007	Goetz et al.
7,236,821	B2	6/2007	Cates et al.
7,273,457	B2	9/2007	Penner et al.
7,283,874	B2	10/2007	Penner et al.
7,286,872	B2	10/2007	Kramer et al.
7,319,903	B2	1/2008	Bange et al.
7,335,161	B2	2/2008	Von Arx et al.
7,353,063	B2	4/2008	Simms, Jr.
7,469,161	B1	12/2008	Gandhi et al.
7,479,108	B2	1/2009	Rini et al.
7,617,001	B2	11/2009	Penner et al.
7,650,185	B2	1/2010	Maile et al.
7,756,587	B2	7/2010	Penner et al.
7,930,031	B2	4/2011	Penner
RE42,378	E	5/2011	Wolinsky et al.
8,078,278	B2	12/2011	Penner
8,271,093	B2	9/2012	Von Arx et al.
8,340,776	B2	12/2012	Doron et al.
8,374,693	B2	2/2013	Chavan et al.
8,577,460	B2	11/2013	Penner
8,593,107	B2*	11/2013	Penner et al. 320/114
2001/0025139	A1	9/2001	Pearlman
2002/0065540	A1	5/2002	Lebel et al.
2002/0077673	A1	6/2002	Penner et al.
2002/0151770	A1	10/2002	Noll, III et al.
2002/0169584	A1	11/2002	Fu et al.
2003/0114897	A1	6/2003	Von Arx et al.
2003/0212441	A1	11/2003	Starkweather et al.
2004/0039424	A1	2/2004	Merritt et al.
2004/0133092	A1	7/2004	Kain
2004/0152999	A1	8/2004	Cohen et al.
2004/0172083	A1	9/2004	Penner
2004/0210141	A1	10/2004	Miller
2005/0109338	A1	5/2005	Stahmann et al.
2005/0113705	A1	5/2005	Fischell et al.
2005/0136385	A1	6/2005	Mann et al.
2005/0159785	A1	7/2005	Rueter
2005/0159789	A1	7/2005	Brockway et al.
2005/0177135	A1	8/2005	Hildebrand et al.
2005/0182387	A1	8/2005	Webler
2005/0203444	A1	9/2005	Schonenberger et al.
2005/0265999	A1	12/2005	Bush et al.
2005/0288727	A1	12/2005	Penner
2006/0009818	A1	1/2006	Von Arx et al.
2006/0020307	A1	1/2006	Davis et al.
2006/0025834	A1	2/2006	Von Arx et al.
2006/0031378	A1	2/2006	Vallapureddy et al.
2006/0041287	A1	2/2006	Dewing et al.
2006/0041288	A1	2/2006	Dewing et al.
2006/0058627	A1	3/2006	Flaherty et al.
2006/0064134	A1	3/2006	Mazar et al.
2006/0064135	A1	3/2006	Brockway
2006/0064142	A1	3/2006	Chavan et al.
2006/0085039	A1	4/2006	Hastings et al.

2006/0094967	A1	5/2006	Bennett et al.
2006/0122667	A1	6/2006	Chavan et al.
2006/0142819	A1	6/2006	Penner et al.
2006/0149329	A1	7/2006	Penner
2007/0010742	A1	1/2007	Torp et al.
2007/0055317	A1	3/2007	Stahmann et al.
2007/0142728	A1	6/2007	Penner et al.
2007/0150014	A1	6/2007	Kramer et al.
2007/0162090	A1	7/2007	Penner
2007/0179549	A1	8/2007	Russie
2007/0250126	A1	10/2007	Maile et al.
2008/0015421	A1	1/2008	Penner
2008/0071178	A1	3/2008	Greenland et al.
2008/0103553	A1	5/2008	Penner et al.
2008/0108915	A1	5/2008	Penner
2008/0171941	A1	7/2008	Huelskamp et al.
2008/0195002	A1	8/2008	Thompson et al.
2008/0228094	A1	9/2008	Audet et al.
2008/0243007	A1	10/2008	Liao et al.
2008/0243210	A1	10/2008	Doron et al.
2009/0312650	A1	12/2009	Maile et al.
2009/0326609	A1	12/2009	Doron
2010/0023091	A1	1/2010	Stahmann et al.
2010/0106028	A1	4/2010	Penner et al.
2010/0274302	A1	10/2010	Armstrong et al.
2011/0160804	A1	6/2011	Penner
2013/0218251	A1	8/2013	Penner
2013/0226259	A1	8/2013	Penner
2013/0238044	A1	9/2013	Penner

FOREIGN PATENT DOCUMENTS

EP	1962557	8/2008
JP	59-164035	9/1984
JP	05-023323	2/1993
JP	08-331065	12/1996
JP	09-147284	6/1997
JP	10-093477	4/1998
JP	10-505529	6/1998
JP	2002-515807	5/2002
JP	2002515807 A	5/2002
JP	2004-041724	2/2004
JP	2004041724 A	2/2004
JP	2004-511313	4/2004
JP	2004-537347	12/2004
JP	2005-521528	7/2005
WO	WO 88/02250	4/1988
WO	WO 96/26673	9/1996
WO	WO 97-33513	9/1997
WO	WO 98/43338	10/1998
WO	WO 98/43701	10/1998
WO	WO 98-52142	11/1998
WO	WO 99-04287	1/1999
WO	WO 99/34453	7/1999
WO	WO 00/47109	8/2000
WO	WO 01/28627	4/2001
WO	WO 01/74278	10/2001
WO	WO 01/76687	10/2001
WO	WO 01/97907	12/2001
WO	WO 02/03347	1/2002
WO	WO 02/32502	4/2002
WO	WO 02/089904	11/2002
WO	WO03/002243	1/2003
WO	WO 03/043688	5/2003
WO	WO 03/096889	11/2003
WO	WO 2004/089465	10/2004
WO	WO 2005/009535	2/2005
WO	WO 2005/053786	6/2005
WO	WO 2005/099816	10/2005
WO	WO 2006/017615	2/2006
WO	WO 2006034183	3/2006
WO	WO 2006/060668	6/2006
WO	WO 2006/126401	11/2006
WO	WO 2007/070794	6/2007
WO	WO 2007/080487	7/2007
WO	WO 2007/127696	11/2007

(56)

References Cited

FOREIGN PATENT DOCUMENTS

WO WO 2008/118908 10/2008
 WO WO 2010/062538 6/2010

OTHER PUBLICATIONS

Harrison et al., "A Low-Power Low-Noise CMOS Amplifier for Neural Recording Applications," IEEE Journal of Solid-State Circuits 38(6):958-965, Jun. 2003.

IEEE Transactions on Biomedical Engineering, vol. 42, No. 5, May 1995, Title: Data Transmission from an Implantable Biotelemeter by Load-Shift Keying Using Circuit Configuration Modulator, by Zhengnian Tang, Brian Smith, John H. Schild, and P. Hunter Peckham, pp. 524-528.

Ishiwara et al., "Current Status and Prospects of FET-Type Ferroelectric Memories," Journal of Semiconductor Technology and Science 1(1): 1-14, Mar. 2001.

Neurosurgery Clinics of North America vol. 4, No. 4, Oct. 1993, Hydrocephalus, Title: The Treatment of Hydrocephalus by Paul M. Kanev, MD, and T.S. Park, MD., pp. 611-619.

Neurosurgery Clinics of North America, vol. 4, No. 4, Oct. 1993, Hydrocephalus, Title: Complications in Ventricular Cerebrospinal Fluid Shunting by Jeffrey P. Blount, MD, John A. Campbell, MD, and Stephen J. Haines, MD, pp. 633-656.

Neurosurgery Update II Vascular, Spinal, Pediatric, and Functional Neurosurgery, Published by McGraw-Hill, Inc., 1991, Editors Robert H. Wilkins, M.D., and Setti S. Rengachary, M.D., Title Shunt Complications by R. Michael Scott, pp. 300-319.

Neurosurgery, vol. 34, No. 5, May 1994, Concepts and Innovations, Title: A New Ventricular Catheter for the Prevention and Treatment of Proximal Obstruction in Cerebrospinal Fluid Shunts, by Enrique C.G. Ventureyra, M.D., F.R.C.S.(C), F.A.C.S., Michael J. Higgins, M.D., pp. 924-926.

Neurosurgery, vol. 34, No. 6, Jun. 1994, Rapid Communication, Title: The Use of the Codman-Medos Programmable Hakim Valve in the Management of Patients with Hydrocephalus: Illustrative Cases, by Peter McL. Black, M.D., Ph.D., Rodolfo Hakim, M.D., Nancy Olsen Bailey, R.N., B.S.N., M.B.A., pp. 1110-1113.

Pediatric Neurosurgery 2nd Edition, Surgery of the Developing Nervous System, Published by W.B. Saunders Company Harcourt Brace Jovanovich, Inc., 1989. Title: Treatment of Hydrocephalus by Harold L. Rekate, M.D.; Ventricular Shunts: Complications and Results by Robert L. McLaurin, M.D.; pp. 200-229.

International Search Report and Written Opinion issued in PCT/US2009/062019, 14 pages.

Extended European Search Report issued in EP 10184174, mailed Dec. 7, 2010.

* cited by examiner

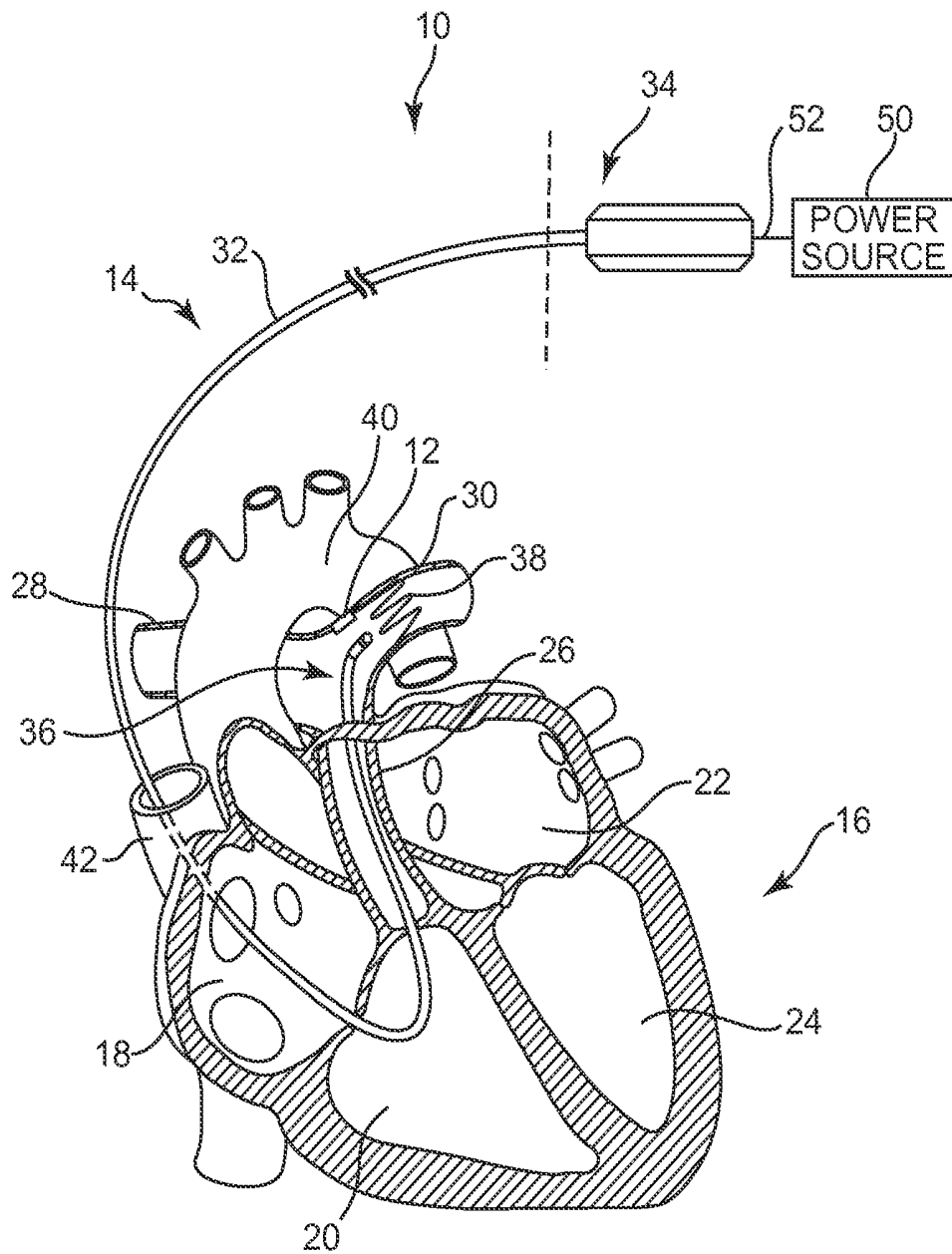

Fig. 1

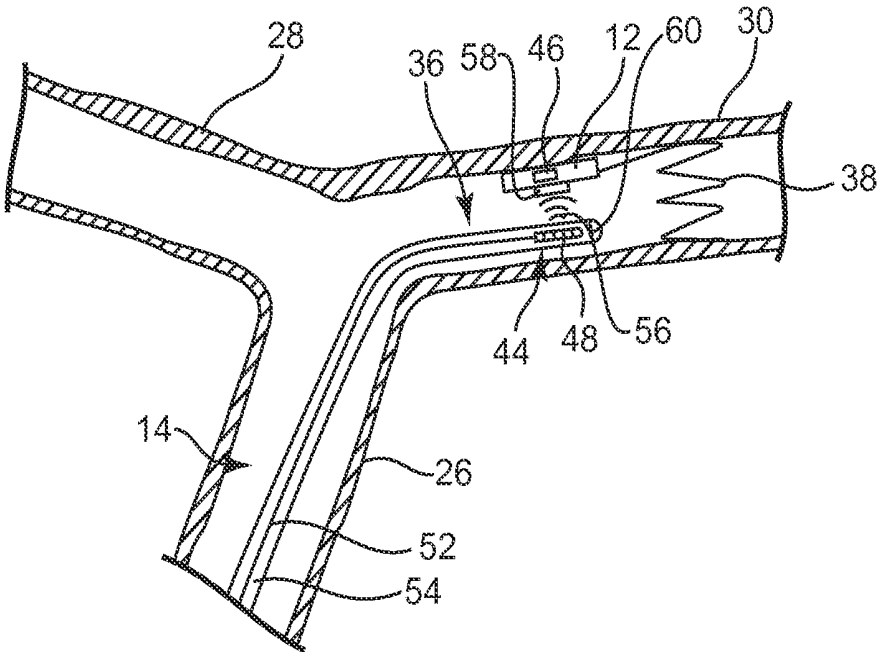

Fig. 2

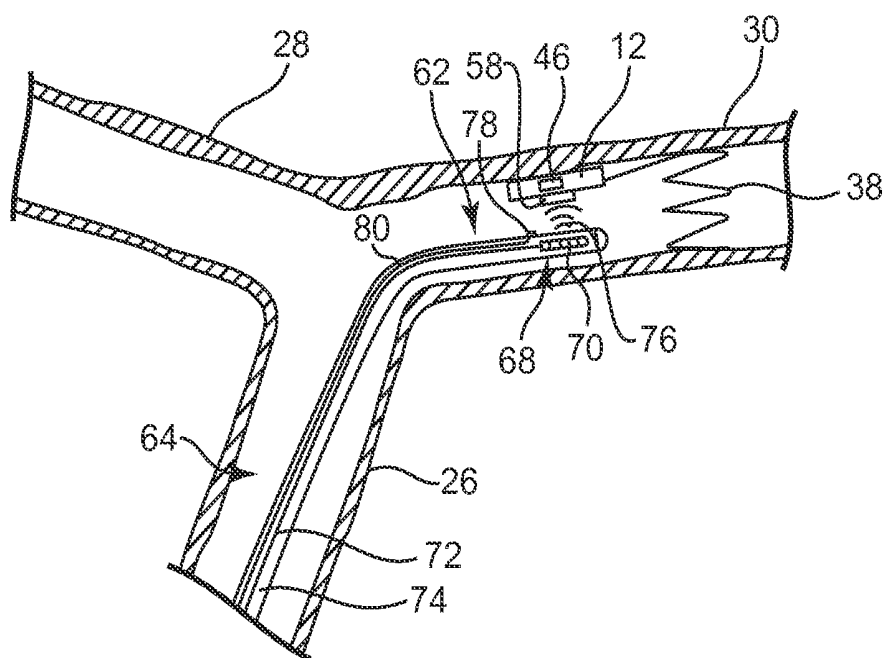

Fig. 3

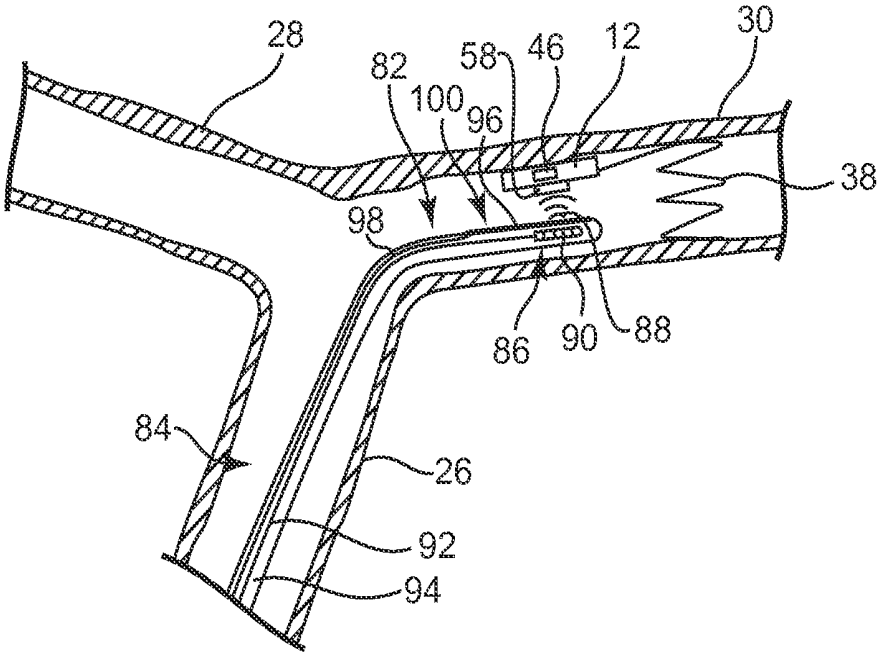

Fig. 4

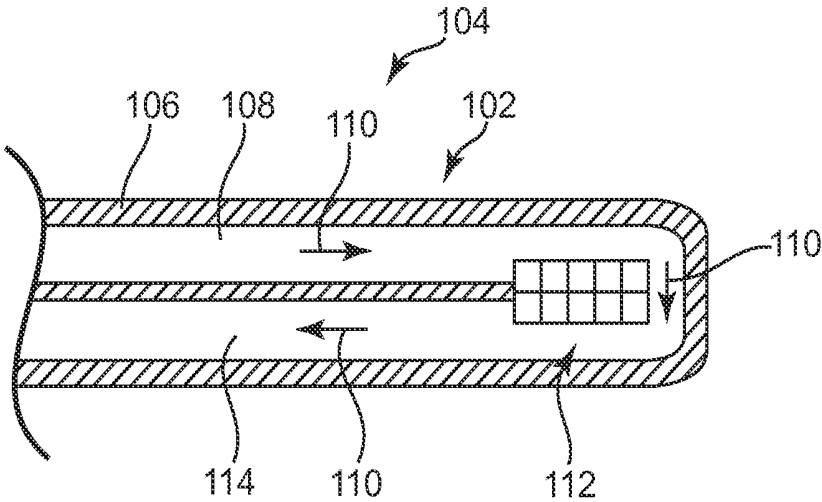

Fig. 5

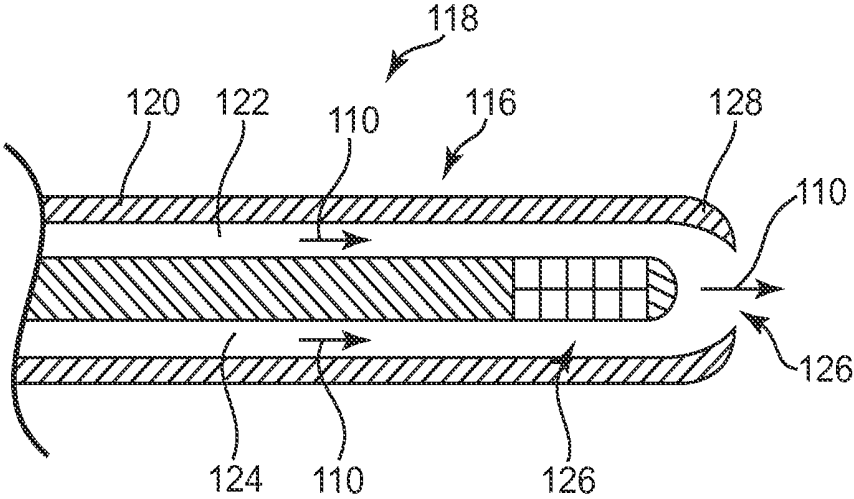

Fig. 6

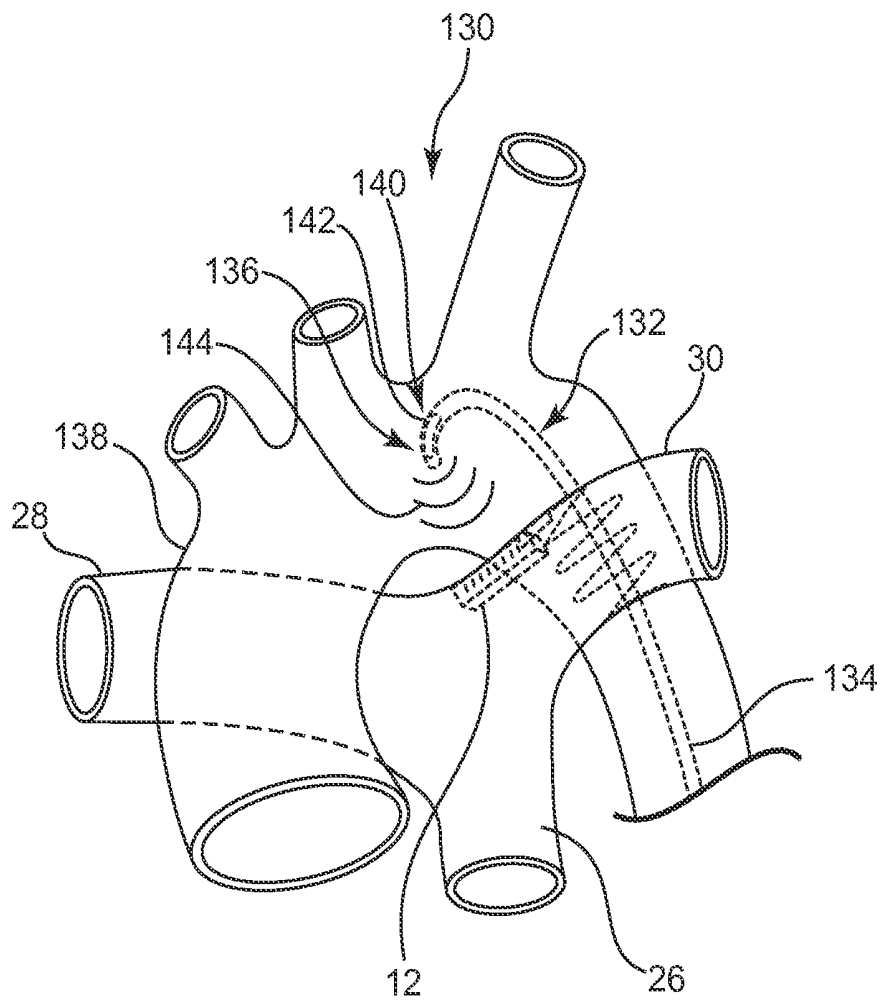

Fig. 7

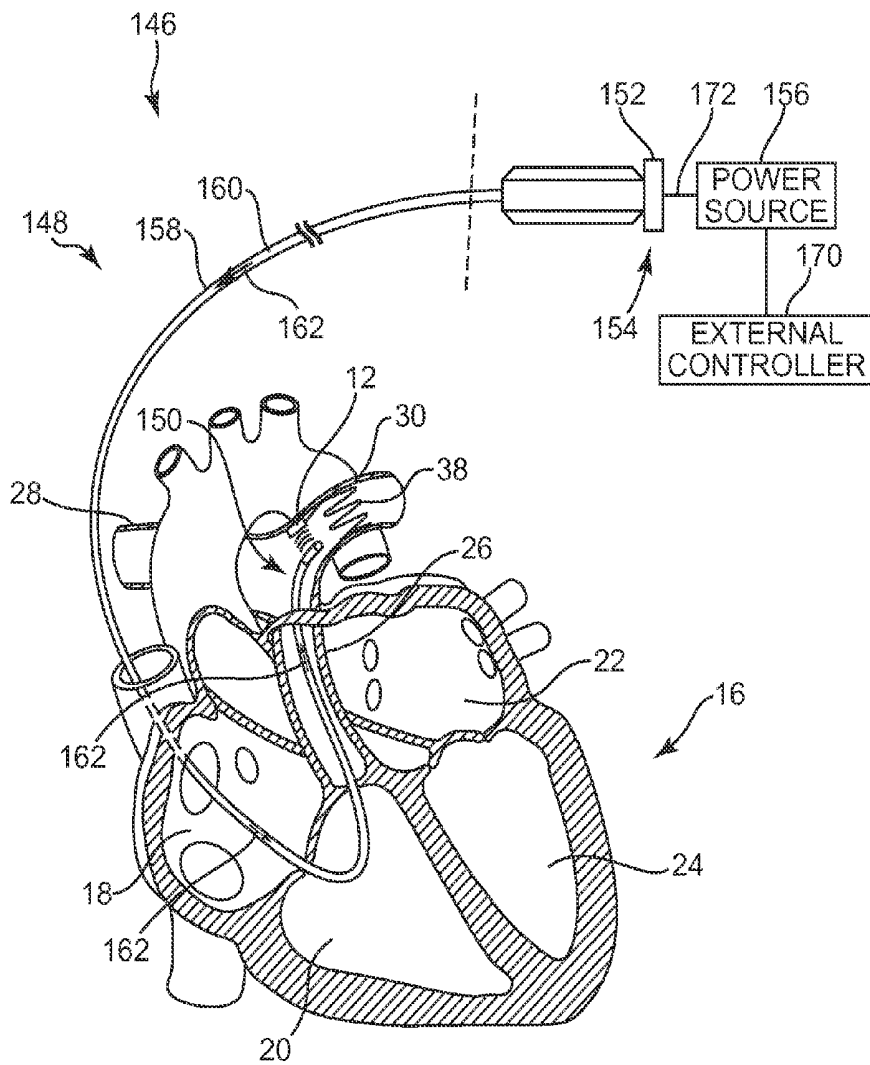

Fig. 8

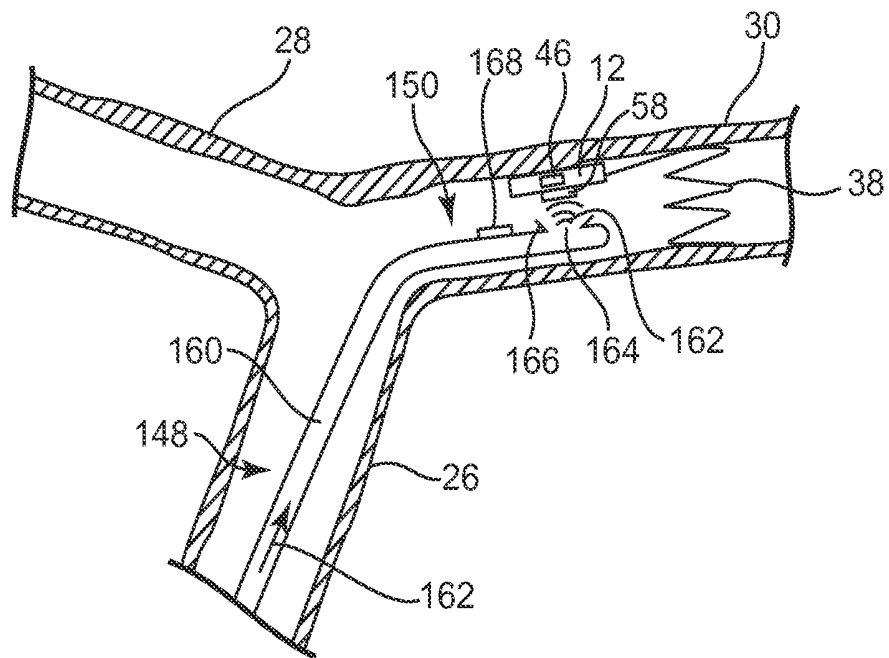

Fig. 9

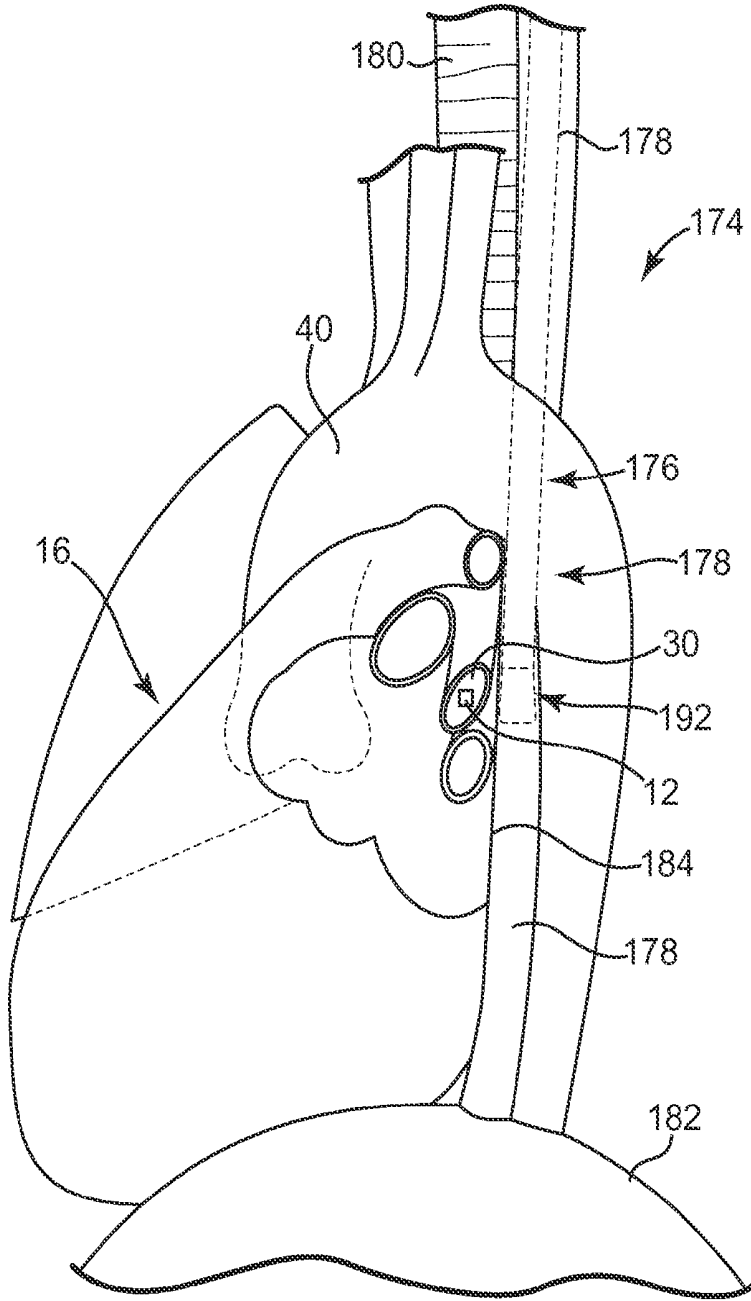

Fig. 10

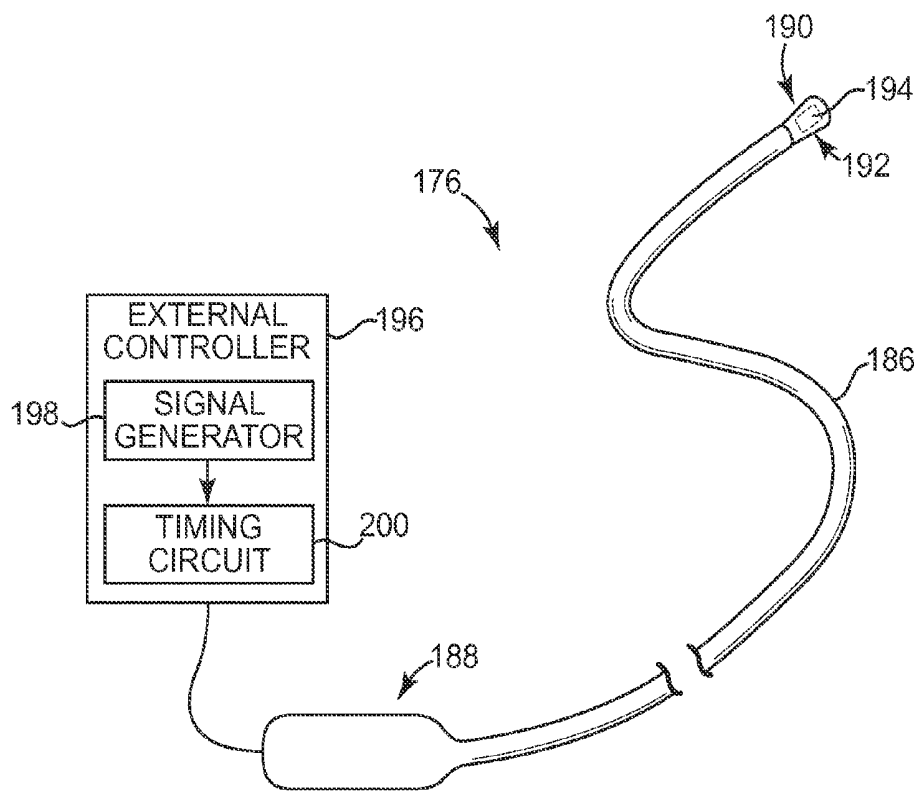

Fig. 11

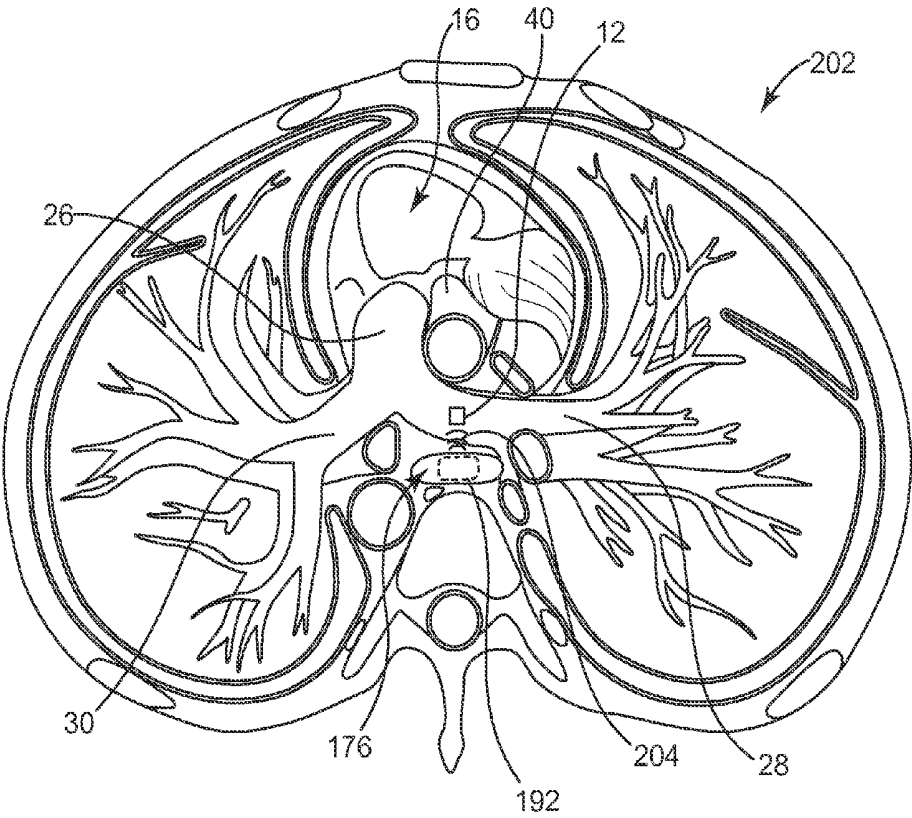

Fig. 12

1

**METHODS AND SYSTEMS FOR
RECHARGING AN IMPLANTED DEVICE BY
DELIVERING A SECTION OF A CHARGING
DEVICE ADJACENT THE IMPLANTED
DEVICE WITHIN A BODY**

CROSS-REFERENCE TO RELATED
APPLICATION

This application is a continuation of U.S. application Ser. No. 12/605,579, filed Oct. 26, 2009, which claims priority under 35 U.S.C. §119 to U.S. Provisional Application No. 61/108,635, filed on Oct. 27, 2008, entitled "Methods and Systems for Recharging Implantable Devices," all of which are incorporated herein by reference in their entirety for all purposes.

TECHNICAL FIELD

The present invention relates generally to implantable medical devices including rechargeable power sources. More specifically, the present invention pertains to methods, systems, and apparatus for recharging medical devices implanted within the body.

BACKGROUND

Actively powered implantable medical devices sometimes require a power supply such as a battery or power capacitor to provide electrical power to the device, in some cases over an extended period of time. In cardiac rhythm management applications, for example, an implantable medical device such as a pressure sensor may require a power supply capable of operating the device over a period of several years. In some cases, the time required to power the device is beyond the capability of the power supply, requiring replacement of the power supply or the implantation of a new device within the body.

With advances in power management and battery technology, more recent trends have focused on the use of small rechargeable power sources for providing power to implantable devices. Current charging techniques often rely on the patient and/or a health-care provider to ensure that the battery is charged periodically. In some cases, the patient may be required to undergo recharging within a clinical environment, which can be burdensome to the patient and often adds to the overall costs associated with recharging. If recharging is to be performed in a clinic, for example, a special area may be required for the patient while the recharging is being performed, adding to the overall cost and time associated with the maintenance.

SUMMARY

The present invention pertains to methods, systems, and apparatus for recharging medical devices implanted within the body. An illustrative recharging system includes a device implanted within the body having a rechargeable power source and a receiver, and a charging device adapted to provide charging energy to the implanted device from a location within the body adjacent to the device. A charging element coupled to the charging device is configured to transmit energy at a location within the body proximate to the receiver. In some embodiments, for example, the charging element includes a source transducer adapted to transmit an acoustic signal to a target transducer coupled to the implanted device for acoustically recharging the device. Alternatively, and in

2

other embodiments, the charging element includes an electromagnetic transmitter adapted to transmit an electromagnetic signal to an antenna or coil coupled to the implanted device for recharging the device using RF or other forms of electromagnetic energy. Other energy transfer modes can also be employed for recharging the implanted device.

An illustrative method of recharging a medical device implanted within a body lumen of a patient's body includes delivering a distal section of the charging device to a location adjacent to the implanted device, activating a charging element operatively coupled to a power source and wirelessly transmitting energy to a receiver coupled to the implanted device, and converting the energy received by the receiver into electrical energy for charging the implanted device. The charging device can be positioned at a target location within the same body lumen as the implanted device, or alternatively, within a different body lumen. For recharging a pressure sensor implanted within a pulmonary artery, for example, the charging device can be delivered to a location within the pulmonary artery, an adjacent artery, or an adjacent lumen or cavity such as the aorta or esophagus. Once positioned adjacent to the implanted device, the charging element can be activated to transmit charging energy to the device from a position within the body. In some embodiments, the charging device can be used to perform other functions within the body such as calibrating the implanted device, confirming the proper operation of the charging device, and/or performing therapy within the body.

While multiple embodiments are disclosed, still other embodiments of the present invention will become apparent to those skilled in the art from the following detailed description, which shows and describes illustrative embodiments of the invention. Accordingly, the drawings and detailed description are to be regarded as illustrative in nature and not restrictive.

BRIEF DESCRIPTION OF THE DRAWINGS

FIG. 1 is a schematic view of an illustrative system for recharging a medical device implanted within a body lumen;

FIG. 2 is a partial cross-sectional view showing the distal section of the charging device of FIG. 1 inserted at a target location within the body adjacent to the implanted device;

FIG. 3 is a partial cross-sectional view showing the distal section of a charging device in accordance with another illustrative embodiment including a sensor;

FIG. 4 is a partial cross-sectional view showing the distal section of a charging device in accordance with another illustrative embodiment including a thermocouple wire;

FIG. 5 is a partial cross-sectional view showing the distal section of a charging device in accordance with another illustrative embodiment including a cooling lumen;

FIG. 6 is a partial cross-sectional view showing the distal section of a charging device in accordance with another illustrative embodiment including a cooling lumen;

FIG. 7 is a schematic view showing another illustrative system for recharging a medical device implanted within a body lumen;

FIG. 8 is a schematic view showing another illustrative system for recharging a medical device implanted within a body lumen;

FIG. 9 is a partial cross-sectional view showing the distal section of the charging device of FIG. 8 inserted at a target location within the body adjacent to the implanted device;

FIG. 10 is a schematic view showing another illustrative system for recharging a medical device implanted within a body lumen;

FIG. 11 is another view of the charging device of FIG. 10; and

FIG. 12 is a transverse view of a patient's thorax, showing the insertion of the charging device of FIG. 10 in the esophagus adjacent to a medical device implanted within the right pulmonary artery.

While the invention is amenable to various modifications and alternative forms, specific embodiments have been shown by way of example in the drawings and are described in detail below. The intention, however, is not to limit the invention to the particular embodiments described. On the contrary, the invention is intended to cover all modifications, equivalents, and alternatives falling within the scope of the invention as defined by the appended claims.

DETAILED DESCRIPTION

FIG. 1 is a schematic view of an illustrative system 10 for recharging a medical device implanted within a body lumen. The system 10, illustratively a system for recharging a device 12 implanted within a pulmonary artery, includes a charging catheter 14 adapted for insertion at a target location within a patient's body such as in or near the heart 16. The heart 16 includes a right atrium 18, a right ventricle 20, a left atrium 22, and a left ventricle 24. The right ventricle 20 leads to the main pulmonary artery 26, which further branches to the right pulmonary artery 28 and the left pulmonary artery 30, as shown.

The charging catheter 14 includes an elongate shaft 32 having a proximal section 34 located outside of the patient's body, and a distal section 36 insertable into the patient's body at a location adjacent to the implanted device 12. In the illustrative embodiment of FIG. 1, the distal section 36 of the elongate shaft 32 is shown inserted into the main pulmonary artery 26 of the heart 16 at a location adjacent to the device 12, which is shown secured within a portion of the left pulmonary artery 30 via a fixation element 38. The distal section 36 of the charging catheter 14 can be positioned at other locations within the body, including the right pulmonary artery 28, the left pulmonary artery 30, or an adjacent vessel or body lumen such as the aorta 40, as discussed further herein. The positioning of the charging catheter 14 within the body will typically depend on the implantation location and configuration of the implanted device 12 to be recharged, the anatomy surrounding the implanted device 12, as well as other factors.

In some embodiments, the charging catheter 14 can be inserted into the main pulmonary artery 26 via an intravenous approach from a percutaneous access site such as a femoral artery or jugular vein. As shown in FIG. 1, for example, delivery of the charging catheter 14 to a target location within the body can occur intravenously through the superior vena cava 42, the right atrium 18, the right ventricle 20, and the main pulmonary artery 26. Other techniques for inserting the charging catheter 14 into the right pulmonary artery 26 are also possible. In some alternative embodiments, for example, the charging catheter 14 can be inserted into the main pulmonary artery 26 via an intra-arterial approach, percutaneously without the aid of vascular conduits, or via the esophagus, airway, or other conduit.

The implanted device 12 can be configured to perform one or more designated functions, including the sensing of physiological parameters within the body and/or providing therapy to the patient. Example physiological parameters that can be sensed using the implanted device 12 include, but are not limited to, blood pressure, blood or fluid flow, temperature, and strain. Various electrical, chemical, and/or magnetic properties may also be sensed within the body using the

implanted device 12. The specific configuration and function to be performed by the implanted device 12 will typically vary depending on the particular therapeutic needs of the patient.

In some embodiments, the implanted device 12 comprises a pressure sensor adapted to sense arterial blood pressure within a pulmonary artery. As shown in the illustrative system 10 of FIG. 1, for example, the implanted device 12 may comprise a pressure sensor implanted in the left pulmonary artery 30 for sensing arterial blood pressure. Alternatively, and in other embodiments, the device 12 may be implanted in the right pulmonary artery 28, the main pulmonary artery 26, or in another vessel leading into or from the heart 16. The implanted device 12 can also be implanted at other locations within the heart 16 such as in the right atrium 18, the right ventricle 20, the left atrium 22, or the left ventricle 24. In some embodiments, the implanted device 12 can be placed at other locations in the body such as within an organ such as the liver or kidney, the vasculature, muscle tissue, or an airway within the body.

The implanted device 12 can be used as part of a cardiac rhythm management (CRM) system to predict decompensation of a heart failure patient, to optimize pacing and/or defibrillation therapy, as well as perform other designated functions within the body. In certain embodiments, for example, the implanted device 12 can be configured to transmit sensed physiological parameters to other CRM system components located within the body such as a pacemaker or defibrillator. In some embodiments, the implanted device 12 can be configured to transmit sensed physiological parameters to an external device such as a monitor or programmer for further monitoring and/or processing. Based on this information, an indication of any abnormalities within the heart 16 can be determined and an appropriate therapy provided to the patient, as necessary.

FIG. 2 is a partial cross-sectional view showing the distal section 36 of the charging catheter 14 of FIG. 1 inserted at a target location within the body adjacent to the implanted device 12. As can be further seen in FIG. 2, and in some embodiments, the distal section 36 of the charging catheter 14 includes a charging element 44 adapted to transmit energy to the implanted device 12 that can be used to charge a rechargeable battery 46 within the device 12. In certain embodiments, for example, the charging element 44 includes an ultrasonic transducer 48 electrically coupled to an external power source 50 via a number of wires 52 extending through an interior lumen 54 of the charging catheter 14. An example piezoelectric transducer that can be used for acoustically transmitting charging energy to the implanted device 12 is described, for example, in U.S. Pat. No. 6,140,740, entitled "Piezoelectric Transducer," which is incorporated herein by reference in its entirety. Other types of acoustic transducers can also be utilized for providing charging energy to the implanted device 12. In some embodiments, the ultrasonic transducer 48 includes an array of ultrasonic elements.

During recharging, the power source 50 can be configured to deliver a time-varying excitation current to the ultrasonic transducer 48, causing the transducer 48 to generate an acoustic signal 56 within the body that is received by a receiver 58 coupled to the implanted device 12. In some embodiments, for example, the receiver 58 comprises an ultrasonic transducer sensitive to the frequency of the acoustic signal 56 transmitted from the source ultrasonic transducer 48. The acoustic signal 56 received by the target ultrasonic transducer 58 is then converted into electrical energy that can be used to recharge the battery 46.

During delivery, the source ultrasonic transducer 48 on the charging catheter 14 can be positioned in close proximity to

the target ultrasonic transducer **58** of the implanted device **12**. In certain embodiments, for example, the distal section **36** of the charging catheter **14** can be positioned such that the source ultrasonic transducer **48** is located a distance of between about 1 mm to about 10 mm apart from the target ultrasonic transducer **58**. The distance at which the two transducers **48,58** are spaced apart from each other may be greater or lesser, however, depending on the type of transducers **48,58** employed, the intensity and frequency characteristics of the acoustic signal **56** transmitted, the anatomy surrounding the transducers **48,58**, as well as other factors. In some embodiments, the positioning of the charging catheter **14** can be accomplished under the aid of fluoroscopy. A radiopaque marker band **60** placed at or near the distal end of the charging catheter **14** can be used in conjunction with a fluoroscope to visualize the location of the charging catheter **14** during delivery so as to minimize the distance between the transducers **48,58**.

Once the distal section **36** of the charging catheter **14** is positioned at a target location within the body adjacent to the implanted device **12**, the ultrasonic transducer **48** can be activated to transmit an acoustic signal **56** to the implanted device **12** for recharging the battery **46** in vivo. The time required to deliver a sufficient amount of charging energy to recharge the battery **46** may be affected by several factors, including the location of the device **12** within the body, the location of the charging catheter **14** within the body, the distance between the source and target ultrasonic transducers **48,58**, and the intensity and frequency of the acoustic signal **56**. Typically, the acoustic intensity of the acoustic signal **56** falls off inversely proportional to the square of the distance from the ultrasonic transducer **48**. Thus, for a given flux of energy, there is an initial rapid decrease in intensity in the near field followed by a more gradual decline further away from the transducer **48**.

By placing the source and target transducers **48,58** in close proximity to each other, the attenuation loss associated with the rapid fall off of acoustic energy in the near field is reduced, resulting in an increase in charge coupling efficiency. This increase in efficiency reduces the overall time required to recharge the battery **46**, and subjects the body to less energy than would otherwise be required to recharge the battery **46** via an external recharging approach with the source ultrasonic transducer transmitting the charging energy directly into the body. This results in a higher intensity field in the vicinity of the implanted device **12** while maintaining a lower overall energy flux transmitted into the body. In addition, because the source transducer **48** is located in close proximity to the target transducer **58**, a smaller portion of the transmitted acoustic energy is absorbed and/or scattered within the body, resulting in more efficient charging with reduced body tissue and fluid heating.

Although the illustrative charging catheter **14** of FIG. 2 includes an ultrasonic transducer **48** for acoustically recharging the implanted device **12**, in other embodiments the charging element **44** can use other energy transfer modes for transmitting charging energy to the device **12**. Examples of other types of energy transfer modes can include, but are not limited to, inductive, electromagnetic, RF, optical (e.g., infrared light, visible light, ultraviolet light, and X-ray), vibration (e.g., transverse and longitudinal mechanical vibrations), radioactive energy, heat, and/or pressure. In one alternative embodiment, for example, the charging element **44** comprises a transmitter adapted to transmit electromagnetic energy to the implanted device **12**. The electromagnetic energy transmitted by the charging element **44** is received by an antenna or coil coupled to the implanted device **12**, which

is then converted into electrical energy for recharging the battery **46**. As with an acoustic energy transfer mode, the transmitter can be positioned in close proximity to the antenna or coil in order to reduce attenuation and absorption of the transmitted electromagnetic energy. In certain embodiments, for example, the charging catheter **14** can be positioned such that the charging element **44** is located a distance of between about 1 mm to about 10 mm apart from the antenna or coil for the implanted device **12**.

In some embodiments, the charging catheter **14** further includes a focusing or collimating element adapted to direct and focus the charging energy transmitted to the implanted device **12**. In those embodiments in which the charging element **44** includes an ultrasonic transducer **48**, for example, the charging element **44** may further include an acoustic baffle or lens for focusing the acoustic signal **56** in the direction of the target transducer **58**. In some embodiments, focusing of the acoustic signal **56** may occur by selectively activating one or more ultrasonic transducer elements within a transducer array, by adjusting the timing or phase of one or more ultrasonic transducer elements, and/or by adjusting the intensity levels of one or more ultrasonic transducer elements. Other techniques for focusing the transmitted acoustic signal **56** are also possible.

In certain embodiments, the charging element **44** is configured to provide charging energy to the implanted device **12** by directly contacting a surface on the device **12**. In one such embodiment, for example, the charging element **44** includes an electrode adapted to electrically contact a corresponding electrode on the implanted device **12**. During delivery, the distal section **36** of the charging catheter **14** can be positioned within the body such that the two electrodes make electrical contact with each other. Once positioned, the electrode on the charging catheter **14** can be energized, causing current to flow to the electrode on the implanted device **12**. As with other energy transmission modes discussed herein, the charging energy received by the implanted device **12** can then be used to recharge the battery **46**.

FIG. 3 is a partial cross-sectional view showing the distal section **62** of a charging catheter **64** in accordance with another illustrative embodiment including a sensor. As shown in FIG. 3, the distal section **62** of the charging catheter **64** includes a charging element **68** adapted to transmit energy to the implanted device **12**, which can be used to charge a rechargeable battery **46** within the device **12**. In certain embodiments, for example, the charging element **68** includes an ultrasonic transducer **70**, or alternatively, multiple ultrasonic transducers **70** each electrically coupled to an external power source via a number of wires **72** extending through an interior lumen **74** of the charging catheter **64**. In use, the ultrasonic transducer(s) **70** can be activated to transmit an acoustic signal **76** to the implanted device **12** for recharging the battery **46** in vivo in a manner similar to that described above with respect to the charging catheter **14** of FIG. 2.

In some embodiments, and as further shown in FIG. 3, the distal section **62** of the charging catheter **64** further includes at least one sensor **78** electrically coupled to the power source **50** via a wire **80** and adapted to monitor one or more parameters associated with the operation of the charging catheter **64** and/or the surrounding environment. Example parameters related to the operation of the charging catheter **64** that can be monitored can include, but are not limited to, parameters related to the energy transmitted by the ultrasonic transducer(s) **70** such as peak power, average power, or power gradient. Example parameters related to the surrounding environment that can be monitored can include, but are not limited to, temperature, electrical impedance, electrical

potential, dielectric coefficient, and/or changes in one or more of these parameters. The sensor 78 can also be configured to sensor other parameters associated with the operation of the charging catheter, the implanted device 12, and/or the surrounding environment.

In certain embodiments, the sensor 78 is a temperature sensor 78 adapted to measure the temperature of body tissue and/or the local blood temperature at or near the location of the implanted device 12. In some embodiments, for example, the temperature sensor 78 can be configured to sense the local blood temperature of blood in the path of the acoustic signal 76, which can be used to estimate the temperature of the body tissue adjacent to the implanted device 12. The charging catheter 64 can be positioned within the vessel such that the temperature sensor 78 contacts the body tissue within the vessel, allowing the sensor 78 to directly sense the body tissue temperature adjacent to the implanted device 12. Based on the monitored temperature, the system can then either reduce the power of the acoustic energy transmitted by the ultrasonic transducer(s) 70, or alternatively, disable one or more of the transducers 70 in the event the temperature exceeds a maximum temperature threshold value. The monitored temperature can also be provided as feedback to notify a clinician of a potentially hazardous condition related to the operation of the charging catheter 64. The temperature sensor 78 can also be utilized to perform other tasks such as calibrating the charging element 68.

In some embodiments, the sensor 78 can be configured to monitor for the presence of any electrical leakage from the charging element 68. For example, the sensor 78 can comprise a sensor adapted to detect the presence of any current leakage from the ultrasonic transducer(s) 70 into the surround anatomy. The monitoring of electrical leakage from the ultrasonic transducers 70 can be accomplished, for example, by measuring the current into and out of the transducers 70 using a differential current transformer, a bridge circuit, or the like. If an electrical leakage is detected, and depending on its magnitude, the system can then either adjust the operating power provided to one or more of the ultrasonic transducers 70 or disable the transducers 70 in order to reduce or eliminate the electrical leakage. This may be useful, for example, in acoustic charging systems that deliver relatively high voltages to the transducer elements. The charging system can also be configured to notify the clinician if a fault condition has occurred in the charging catheter 64.

The implanted device 12 can be further configured to monitor a number of parameters associated with the acoustic signal 76 received from the charging catheter 64. For example, in those embodiments in which the implanted device 12 includes an energy exchanger (e.g., an ultrasonic transducer), the implanted device 12 can be configured to monitor the power or intensity of the acoustic signal 76 transmitted by the charging catheter 64 to determine whether the signal 76 is within an acceptable range. If the received acoustic signal 76 exceeds a maximum power or intensity value, for example, the implanted device 12 can be configured to communicate a signal back to the charging catheter 64, which can be used by the catheter 64 as feedback to adjust the intensity or power of the signal 76. In some embodiments, the feedback signal can also be used by the clinician to aid in repositioning the charging catheter 64 within the vessel to maximize the charge coupling efficiency between the catheter 64 and the implanted device 12. In one embodiment, for example, the feedback signal can be used to adjust the placement location of charging catheter 64, and in particular the location of the charging element 68 within the vessel, in order to optimize the charging energy received by the implanted device 12.

FIG. 4 is a partial cross-sectional view showing the distal section 82 of charging catheter 84 in accordance with another illustrative embodiment including a thermocouple wire for sensing temperature. As shown in FIG. 4, the distal section 82 of the charging catheter 84 includes a charging element 86 adapted to transmit a signal 88 to the implanted device 12. In certain embodiments, the charging element 86 includes an ultrasonic transducer 90, or alternatively, multiple ultrasonic transducers 90 each electrically coupled to an external power source via a number of wires 92 extending through an interior lumen 94 of the charging catheter 84.

In some embodiments, and as further shown in FIG. 4, the charging catheter 84 includes a thermocouple wire 96 adapted to sense the temperature of the body tissue and/or local blood temperature within the vessel at or near the location of the implanted device 12. The thermocouple wire 96 can be embedded within the charging catheter 84 at a location at or near the charging element 86, and can be electrically coupled to sensing electronics within the external power source 50 via a wire 98. The thermocouple wire 96 can be fabricated from a relatively thin gauge metal capable of sensing relatively small changes in temperature. In some embodiments, the sensing electronics can comprise a differential amplifier adapted to convert sensed thermal potential differences into an electrical potential difference indicative of a change in temperature due to the transmitted charging energy.

In use, the thermocouple wire 96 can be configured to sense temperature at the distal section 82 of the charging catheter 84, which can then be used to estimate the temperature of the body tissue and/or blood in the path of the acoustic signal 88. In some embodiments, an exposed portion 100 of the thermocouple wire 96 may permit the wire 96 to sense the local temperature within the blood vessel or, if placed into contact with the vessel wall, the body tissue temperature. The exposed portion 100 of the thermocouple wire 96 can also be used to sense other parameters within the vessel. In certain embodiments, for example, the exposed portion 100 of the thermocouple wire 96 may also function as a voltmeter probe to detect the presence of any electrical leakage from the charging element 86 by measuring electrical potentials within the vessel.

In another embodiment, the thermocouple wire 96 can be coupled directly to the charging element 86 for monitoring the temperature of the element 86 itself. For an acoustic recharging system including an ultrasonic transducer 90, for example, the thermocouple wire 96 can be attached to a portion of the transducer 90 to monitor the temperature of the transducer 90 during recharging. Since heating in the vessel is due in part to heat conduction from the ultrasonic transducer 90, the temperature within the vessel can be monitored indirectly using the thermocouple wire 96. The sensed temperature on the ultrasonic transducer 70 can then be used as feedback for regulating the operating power provided to the transducer 70.

FIG. 5 is a partial cross-sectional view showing the distal section 102 of a charging catheter 104 in accordance with another illustrative embodiment including a cooling lumen. As shown in FIG. 5, the charging catheter 104 includes an elongate shaft 106 having an internal lumen 108 in fluid communication with a cooling medium 110 that can be used for cooling a charging element 112 and/or the body tissue and fluids surrounding the distal section 102 of the catheter 104. The cooling medium 110 may comprise a liquid or gas delivered to the distal section 102 of the charging catheter 104 from a source operatively coupled to the proximal section of the catheter 104. In some embodiments, the cooling medium 110 can be configured to change its aggregation state from a

liquid to gas when heated. In certain embodiments, for example, the cooling medium **110** comprises a pressurized source of liquid nitrogen operatively coupled to the charging catheter **104** at a location external to the body. Upon heating from the charging element **112**, the liquid nitrogen can be configured to change from an initial liquid state to a gaseous state, absorbing heat produced by activation of the element **112** during recharging. Examples of other suitable cooling mediums **110** can include, but are not limited to, air, carbon dioxide, helium, neon, argon, saline, water, or a Freon-based solution.

In some embodiments, an additional lumen **114** can be used as a return line to return the cooling medium **110** back to the proximal section of the charging catheter **104** once heated. During recharging, the cooling medium **110** can be circulated through the interior of the distal section **102** to dissipate the heat generated by the charging element **112** and to reduce heating of the body tissue and fluids surrounding the catheter **104**. In some embodiments, the temperature of the cooling medium **110** can be reduced to a temperature below room temperature to further aid in dissipating heat generated by the charging element **112**.

During recharging, the presence of the cooling medium **110** within the lumens **108,114** facilitates operation of the charging element **112** at higher intensity levels without causing significant heating in the surrounding body tissue and fluids. When the charging catheter **104** is implanted in a pulmonary artery, for example, the presence of the cooling medium **110** facilitates operation of the charging element **112** at greater intensity levels without heating the blood within the artery. The ability to operate at higher intensity levels without heating may reduce the overall time required to recharge the battery within the implanted device.

FIG. 6 is a partial cross-sectional view showing the distal section **116** of a charging catheter **118** in accordance with another illustrative embodiment including a cooling lumen. Similar to the embodiment of FIG. 5, the charging catheter **118** includes an elongate shaft **120** having one or more internal lumens **122,124** in fluid communication with a cooling medium **110** that can be used for cooling a charging element **126** and/or body tissue and fluids surrounding the distal section **116** of the catheter **118**. In the embodiment of FIG. 6, the lumens **122,124** terminate distally at an exit port **126** disposed at or near the distal end **128** of the charging catheter **118**. In some embodiments, multiple exit ports may be provided at or near the distal end **128** of the elongate shaft **120** and/or may be provided at various other locations along the length of the shaft **120**.

During recharging, a pressurized cooling medium **110** (e.g., saline) contained within the lumens **122,124** is ejected through the port **126** and into the surrounding anatomy. In recharging applications where the catheter **118** is positioned in a pulmonary artery adjacent to an implanted pressure sensor, for example, the cooling medium **110** may be ejected through the exit port **126** and into the artery for cooling the blood within the artery as well as the pressure sensor. As with the embodiment of FIG. 5, the passage of the cooling medium **110** through the lumens **122,124** further dissipates heat generated by the charging element **126**.

FIG. 7 is a schematic view of another illustrative system **130** for recharging a medical device **12** implanted within a body lumen. In the illustrative embodiment of FIG. 7, a charging catheter **132** including an elongate shaft **134** having a proximal section (not shown) and a distal section **136** is inserted into a different body vessel in close proximity to the vessel containing the implanted device **12**. In an implantable pressure sensor disposed within a pulmonary artery, for

example, the distal section **136** of the charging catheter **132** may be positioned within an adjacent body vessel such as the aorta **138**. Delivery of the charging catheter **132** to the aorta **138** can be accomplished, for example, via a catheterization approach through a coronary artery. Other delivery techniques, however, are possible.

By positioning the charging catheter **132** into a different vessel than the implanted device **12**, access to a target site for recharging may be easier and/or may be less invasive than inserting the catheter **132** directly into the same vessel as the device **12**. In some cases, for example, the implanted device **12** may be implanted within a body lumen that is difficult to access. In such case, delivery of the charging catheter **132** to a different vessel within the body (e.g., the aorta, the right pulmonary artery, the esophagus, etc.) may reduce the overall time and difficulty associated with the recharging process.

Once the charging catheter **132** is positioned at a target location within an adjacent body lumen (e.g., the aorta **138**), a charging element **140** coupled to the catheter **132** can be activated to transmit charging energy into the adjacent vessel (e.g., the left pulmonary artery **30**) for recharging the implanted device **12**. In those embodiments in which the charging element **140** includes an ultrasonic transducer **142**, for example, the transducer **142** can be configured to transmit an acoustic signal **144** that can be received by the implanted device **12** and converted into electrical energy for recharging the device **12**.

In some embodiments, the charging catheter **132** can be used to perform other functions within the body and/or to provide therapy to the patient. In certain embodiments, for example, the charging catheter **132** may be used during a diagnostic or therapeutic coronary artery catheterization (e.g., a right heart catheterization) for treating coronary artery disease within the body. In one such embodiment, the charging element **140** may be provided as part of a coronary balloon catheter for performing an angioplasty procedure on the patient. In such case, recharging of the implanted device **12** may be performed in conjunction with the therapy using the same catheterization.

FIG. 8 is a schematic view showing another illustrative system **146** for recharging a medical device **12** implanted within a body lumen. The system **146**, illustratively a system for recharging a pressure sensor implanted within a pulmonary artery, includes a charging catheter **148** having a distal section **150** inserted at a target location within the patient's body, an external charging element **152** coupled to a proximal section **154** of the charging catheter **148**, and a power source **156**.

The charging catheter **148** includes an elongate shaft **158** having an interior lumen **160** adapted to transmit charging energy generated by the charging element **152** from a location outside of the patient to the distal section **150** of the charging catheter **148**. In some embodiments, for example, the charging element **152** comprises an external ultrasonic transducer that, when energized by the power source **156**, generates an acoustic signal **162** that is transmitted through the interior lumen **160** to the distal section **150** of the catheter **148**. In some embodiments, the ultrasonic transducer **152** comprises an array of ultrasonic transducer elements each of which can be selectively actuated to generate the acoustic signal **162**. During recharging, the interior lumen **160** acts as an acoustic waveguide for the acoustic signal **162**, reducing attenuation and scattering that would normally occur during transmission of the signal **162** directly through the body. Because the charging element **152** is located outside of the patient's body,

the transducer **152** can be of any size and power without significantly impacting the acoustic energy transmitted into the body.

FIG. **9** is a partial cross-sectional view showing the distal section **150** of the charging catheter **148** of FIG. **8** inserted at a target location within the body adjacent to an implanted device **12**. As can be further seen in FIG. **9**, the distal section **150** of the charging catheter **148** includes a port **164** adapted to direct the acoustic signal **162** transmitted through the interior lumen **118** in a direction towards the implanted device **12**. In some embodiments, the interior lumen **160** may contain a liquid or solid material (e.g., saline), which acts as an interface to facilitate transmission of the acoustic energy through the interior lumen **160**. In certain embodiments, the distal section **150** of the charging catheter **148** may further include a focusing or collimating element **166** such as an acoustic baffle or lens to further focus the acoustic signal **162** in a direction towards the implanted device **12**.

In some embodiments, the charging catheter **148** may include other components for use in focusing the charging energy generated by the charging element **152**, either passively or actively. In the embodiment of FIG. **9**, for example, the charging catheter **148** includes a sensor **168** adapted to sense various parameters of the acoustic signal **162** as it is transmitted from the port **164** towards the implanted device **12**. In one embodiment, the sensor **168** is an ultrasonic pressure sensor adapted to sense the intensity and/or phase of the acoustic signal **162** as it exits the port **164**. The sensor **168** can be configured to relay pressure sensor readings to an external controller **170** via a wired or wireless communications link. Based on the sensor readings, the external controller **170** can be configured to run an adaptive algorithm or routine that is used to optimize the direction, focusing, phase, intensity, timing, and/or bandwidth of the acoustic signal **162** generated by the charging element **152**. In some embodiments, for example, the sensor readings can be used to analyze the intensity and phase of the acoustic signal **162** exiting the port **164**, and responsive to these parameters, adjust the intensity and timing of the electrical signal **172** provided to one or more transducer elements of the charging element **152**, either simultaneously or sequentially.

Alternatively, and in other embodiments, the distal section **150** of the charging catheter **148** may include a passive element such as a reflector or an active element such as a repeater adapted to generate a signal **172** that is received by an array of transducer elements. In certain embodiments, for example, the reflected or repeated signal may serve as a reference signal for a time-reversal acoustic algorithm that can be used to generate time reversals on one or more of the transducer elements in order to focus the acoustic signal **162** towards the implanted device **12**. The sensor **168** on the charging catheter **148** can be configured to sense an acoustic signal transmitted by the implanted device **12**. The sensed acoustic signal can then be transmitted to the external controller **170** for computing phase delays for each of the transducer elements. The external controller **170** can then adjust one or more parameters associated with the ultrasonic elements to focus or steer the acoustic signal **162** towards the implanted device **12**. Example parameters that can be adjusted include, but are not limited to, direction, focusing, phase, intensity, timing, and/or bandwidth.

The sensor **168** can be used to perform other functions within the body such as calibrating the implanted device **12**. In those embodiments in which the implanted device **12** comprises a pressure sensor, for example, the sensor **168** may be used as a reference pressure sensor to calibrate the device **12**. In one embodiment, the reference pressure sensor and charg-

ing element can be combined into a single catheter. The ability to calibrate the implanted device **12** without subjecting the patient to an additional catheterization process may reduce the time and complexity associated with servicing the implanted device **12**.

FIG. **10** is a schematic view of another illustrative system **174** for recharging a medical device **12** implanted within a body lumen using a transesophageal approach. In the embodiment of FIG. **10**, a charging device **176** is inserted transesophageally into the esophagus **178** of the patient. The esophagus **178** is located posterior to the heart **16** and the airway **180**, and extends downwardly to the stomach **182** at a location adjacent to the aorta **40** and the posterior wall **184** of the heart **16**, as shown.

As can be further understood in conjunction with FIG. **11**, the charging device **176** includes an elongate shaft **186** having a proximal section **188** and a distal section **190**. The distal section **190** of the charging device **176** includes a cylindrically-shaped charging element **192** adapted to transmit energy from a position within the esophagus **178** to acoustically recharge an implanted device **12** located in an adjacent body lumen such as a pulmonary artery. In some embodiments, the charging element **192** comprises an array of ultrasonic transducers **194** which, when energized via an external controller **196**, generate a radial, omnidirectional acoustic signal that is transmitted through the esophageal wall and into the adjacent pulmonary artery for recharging the implanted device **12**. In some embodiments, the charging element **192** can include a polymeric coating or layer that matches the acoustic impedance of the charging element **192** with the surrounding fluid and tissue in the esophagus **178**. In one embodiment, the charging element **192** and external controller **196** may be provided as part of a transesophageal echocardiogram (TEE) device.

The external controller **196** can include a signal generator **198** and a tuning circuit **200** that can be used to tune the frequency of the acoustic signal generated by the ultrasonic transducers **194** to a particular frequency or range of frequencies based on the resonance characteristics of the ultrasonic transducer elements used to transmit and receive the acoustic charging energy. In certain embodiments, for example, the signal generator **198** and tuning circuit **200** can be used to tune the ultrasonic transducer elements to a frequency of about 40 kHz, which can correspond to a resonance frequency of the ultrasonic transducer on the implanted device **12**. In some embodiments, the signal generator **198** and tuning circuit **200** can be used to tune the ultrasonic transducer elements to operate over a desired range of frequencies (e.g., between about 10 kHz to 200 kHz). Other operating frequencies and frequency ranges are possible, however.

To recharge an implanted device **12** positioned in or near the heart **16**, the distal section **190** of the charging device **176** can be inserted into the patient's esophagus **178** and advanced to a position within the esophagus **178** adjacent to the implantation location of the device **12**. In those embodiments in which the implanted device **12** is located within a pulmonary artery **30**, for example, the distal section **190** of the charging device **176** can be inserted into the esophagus **178** and positioned such that the charging element **192** is located in the mediastinum immediately posterior to the artery **30**, as shown, for example, in FIG. **10**. In some embodiments, the distal section **190** of the charging catheter **176** can be configured to substantially fill the lumen of the esophagus **178** such that a portion of the charging element **192** contacts the esophageal wall. In this position, the charging element **192** is located a short distance (e.g. 1 cm to 2 cm) from the adjacent artery **30**, and provides a direct acoustic path between the

charging element 192 and the implanted device 12. The esophagus 178 comprises primarily water and soft tissue, and is therefore acoustically matched with the impedance of the transducer elements, which helps to reduce losses in acoustic energy due to impedance mismatches.

Once the charging device 176 is positioned within the esophagus 178 adjacent to the body vessel or lumen containing the implanted device 12, the charging element 192 can be activated to generate an acoustic signal that travels through the esophageal wall. As can be further seen in a transverse view of the patient's thorax in FIG. 12, the charging element 192 can be positioned within the esophagus 178 at a location immediately adjacent to a device 12 implanted within the right pulmonary artery 28. In this position, the charging element 192 can be activated to generate an acoustic signal 204 that can be received by the implanted device 12 and converted into electrical energy for recharging the device 12. During recharging, the direct acoustic pathway and relatively short distance between the esophagus 178 and the artery 28 results in an increase in charge coupling efficiency between the charging element 192 and the implanted device 12. As with other embodiments discussed herein, this increase in efficiency reduces the overall time required to recharge the battery within the implanted device 12, and subjects the body to less energy than would otherwise be required to recharge the device 12 via an external recharging approach.

Various modifications and additions can be made to the exemplary embodiments discussed without departing from the scope of the present invention. For example, while the embodiments described above refer to particular features, the scope of this invention also includes embodiments having different combinations of features and embodiments that do not include all of the described features. Accordingly, the scope of the present invention is intended to embrace all such alternatives, modifications, and variations as fall within the scope of the claims, together with all equivalents thereof.

What is claimed is:

1. A rechargeable system, comprising:
a medical device implanted within a patient's heart and configured to provide therapy to the patient, the medical device including a rechargeable power source and a receiver;
a charging device insertable within the body, the charging device including an elongate shaft having a proximal section and a distal section, and a charging element adapted to transmit charging energy to the receiver from an intrabody location adjacent to the medical device.
2. The rechargeable system of claim 1, wherein the charging element is coupled to the distal section of the charging device.
3. The rechargeable system of claim 1, the charging device further including an interior lumen disposed within the elongate shaft, wherein the charging element is coupled to the proximal section of the charging device and is adapted to transmit energy through the interior lumen.
4. The rechargeable system of claim 1, wherein the charging element includes an electromagnetic transmitter.
5. The rechargeable system of claim 4, wherein the receiver includes an antenna or coil configured to receive the transmitted charging energy.

6. The rechargeable system of claim 4, wherein the charging element includes a radio frequency (RF) transmitter.

7. The rechargeable system of claim 4, wherein the charging element includes an optical transmitter configured to transmit at least one of infrared energy, visible energy, ultraviolet energy, and x-ray energy.

8. The rechargeable system of claim 1, wherein the charging element includes an acoustic transducer configured to transmit acoustic energy.

9. The rechargeable system of claim 1, wherein the charging device includes at least one cooling lumen in fluid communication with a cooling medium.

10. The rechargeable system of claim 1, wherein the charging device further includes a temperature sensor for calibrating the charging device.

11. The rechargeable system of claim 10, wherein the temperature sensor comprises a thermocouple wire embedded in a distal section of the charging device.

12. The rechargeable system of claim 1, wherein the charging device includes a sensor configured to sense electrical leakage from the charging element.

13. A recharging device for recharging a medical device implanted within the body of a patient, the medical device including a rechargeable power source and a receiver, the recharging device comprising:

an elongate shaft having a proximal section and a distal section, wherein the distal section is configured to be delivered to a location within the body adjacent to the implanted medical device; and

a charging element adapted to transmit charging energy to the receiver.

14. The recharging device of claim 13, wherein the charging element is coupled to the distal section of the charging device.

15. The recharging device of claim 13, the recharging device further comprising an interior lumen disposed within the elongate shaft, wherein the charging element is coupled to the proximal section of the charging device and is adapted to transmit energy through the interior lumen.

16. The recharging device of claim 13, wherein the charging element includes an electromagnetic transmitter.

17. The recharging device of claim 16, wherein the charging element include a radio frequency (RF) transmitter.

18. The recharging device of claim 13, wherein the charging element includes an acoustic transducer.

19. A rechargeable system, comprising:

a medical device implanted within a patient's body, the medical device including a rechargeable power source and a receiver;

a charging device insertable within the body, the charging device including an elongate shaft having a proximal section and a distal section, and a charging element adapted to transmit charging energy to the receiver from an intrabody location adjacent to the medical device.

20. The rechargeable system of claim 19, wherein the charging element includes a radio frequency (RF) transmitter.

专利名称(译)	用于通过在体内将植入装置附近的充电装置的一部分递送来对植入装置进行再充电的方法和系统		
公开(公告)号	US9024582	公开(公告)日	2015-05-05
申请号	US14/088425	申请日	2013-11-24
[标]申请(专利权)人(译)	心脏起搏器股份公司		
申请(专利权)人(译)	心脏起搏器, INC.		
当前申请(专利权)人(译)	心脏起搏器, INC.		
[标]发明人	PENNER ABRAHAM DORON EYAL STAHMANN JEFFREY E MAILE KEITH R TRAN BINH C LIAO WANGCAI MI BIN HUELSKAMP PAUL		
发明人	PENNER, ABRAHAM DORON, EYAL STAHMANN, JEFFREY E. MAILE, KEITH R. TRAN, BINH C. LIAO, WANGCAI MI, BIN HUELSKAMP, PAUL		
IPC分类号	H02J7/00 A61B5/0215 A61B5/00 A61B5/01 A61B5/026 A61N1/372 A61N1/378		
CPC分类号	A61B5/0215 A61N1/3787 A61B5/0031 A61B5/01 A61B5/026 A61N1/37217		
代理机构(译)	FAEGRE BAKER丹尼尔斯律师事务所		
优先权	61/108635 2008-10-27 US		
其他公开文献	US20140073972A1		
外部链接	Espacenet USPTO		

摘要(译)

公开了用于对植入体内的医疗装置进行再充电的方法, 系统和装置。示例性可充电系统包括充电装置, 该充电装置包括细长轴, 该细长轴具有近端部分和远端部分。远端部分被配置成被递送到与植入的医疗装置相邻的身体内的位置。充电装置包括充电元件, 该充电元件被配置为将充电能量传输到植入的医疗装置的接收器。

