



US 20190336135A1

(19) **United States**

(12) **Patent Application Publication**  
Inouye et al.

(10) **Pub. No.: US 2019/0336135 A1**

(43) **Pub. Date: Nov. 7, 2019**

(54) **OCCLUSIVE SEALING SENSOR SYSTEM**

**Publication Classification**

(71) Applicant: **BOSTON SCIENTIFIC SCIMED, INC.**, MAPLE GROVE, MN (US)  
  
(72) Inventors: **Joshua Mark Inouye**, Maple Grove, MN (US); **Alex Pflugfelder**, Excelsior, MN (US); **Brian T. Berg**, Saint Paul, MN (US); **David John Onushko**, Maple Grove, MN (US); **James M. Anderson**, Corcoran, MN (US); **Markus Petteri Lohi**, Big Lake, MN (US)

(51) **Int. Cl.**  
*A61B 17/12* (2006.01)  
*A61B 5/00* (2006.01)  
*A61B 5/07* (2006.01)  
*A61B 5/0205* (2006.01)  
  
(52) **U.S. Cl.**  
CPC ..... *A61B 17/12122* (2013.01); *A61B 5/4851* (2013.01); *A61B 5/07* (2013.01); *A61B 5/0215* (2013.01); *A61B 5/6852* (2013.01); *A61B 5/686* (2013.01); *A61B 17/12031* (2013.01); *A61B 5/02055* (2013.01)

(73) Assignee: **BOSTON SCIENTIFIC SCIMED, INC.**, MAPLE GROVE, MN (US)

(21) Appl. No.: **16/400,750**

(22) Filed: **May 1, 2019**

**Related U.S. Application Data**

(60) Provisional application No. 62/665,830, filed on May 2, 2018.

(57) **ABSTRACT**

An example system for detecting leakage around an implant is disclosed. The example system for detecting leakage around an occlusive implant disposed in the left atrial appendage includes an elongate shaft having a port disposed at a distal end region thereof and a first sensor disposed adjacent the elongate shaft. The elongate shaft is configured to be positioned adjacent the occlusive implant such that the first sensor is positioned on a first side of the occlusive implant and the port is positioned on a second side of the occlusive implant. Further, the first sensor is configured to measure a first parameter and the first parameter is utilized to determine a fluid leak between the occlusive implant and a tissue wall defining the left atrial appendage.

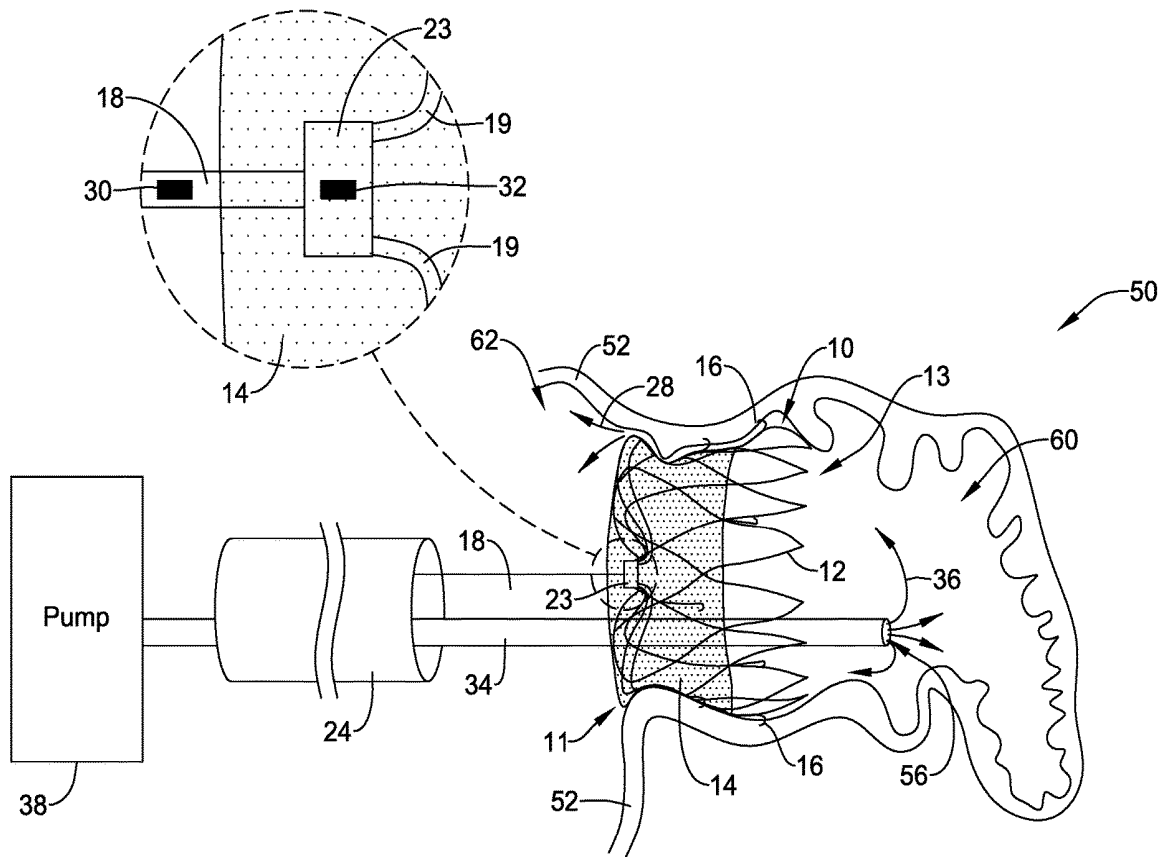

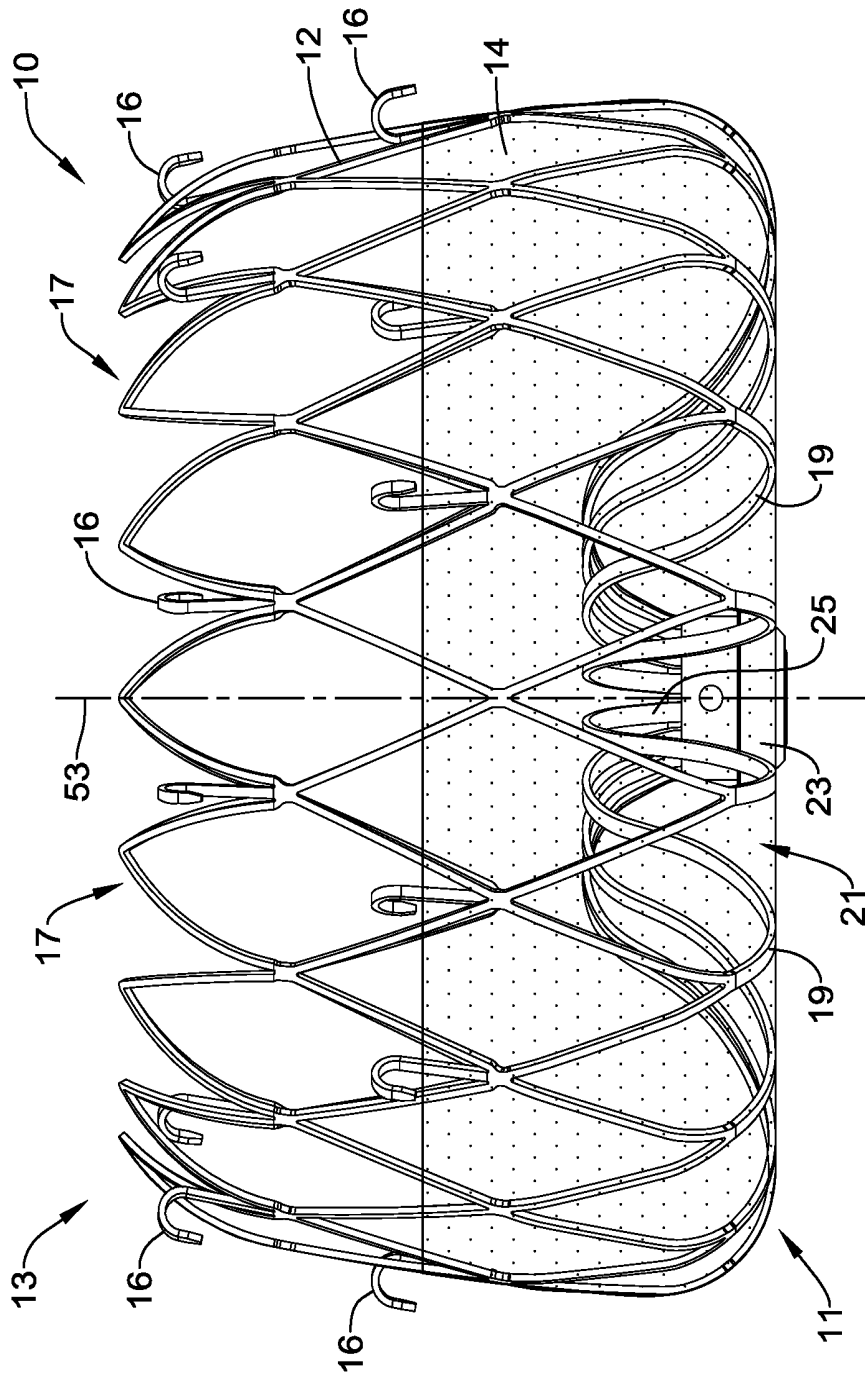

FIG. 1

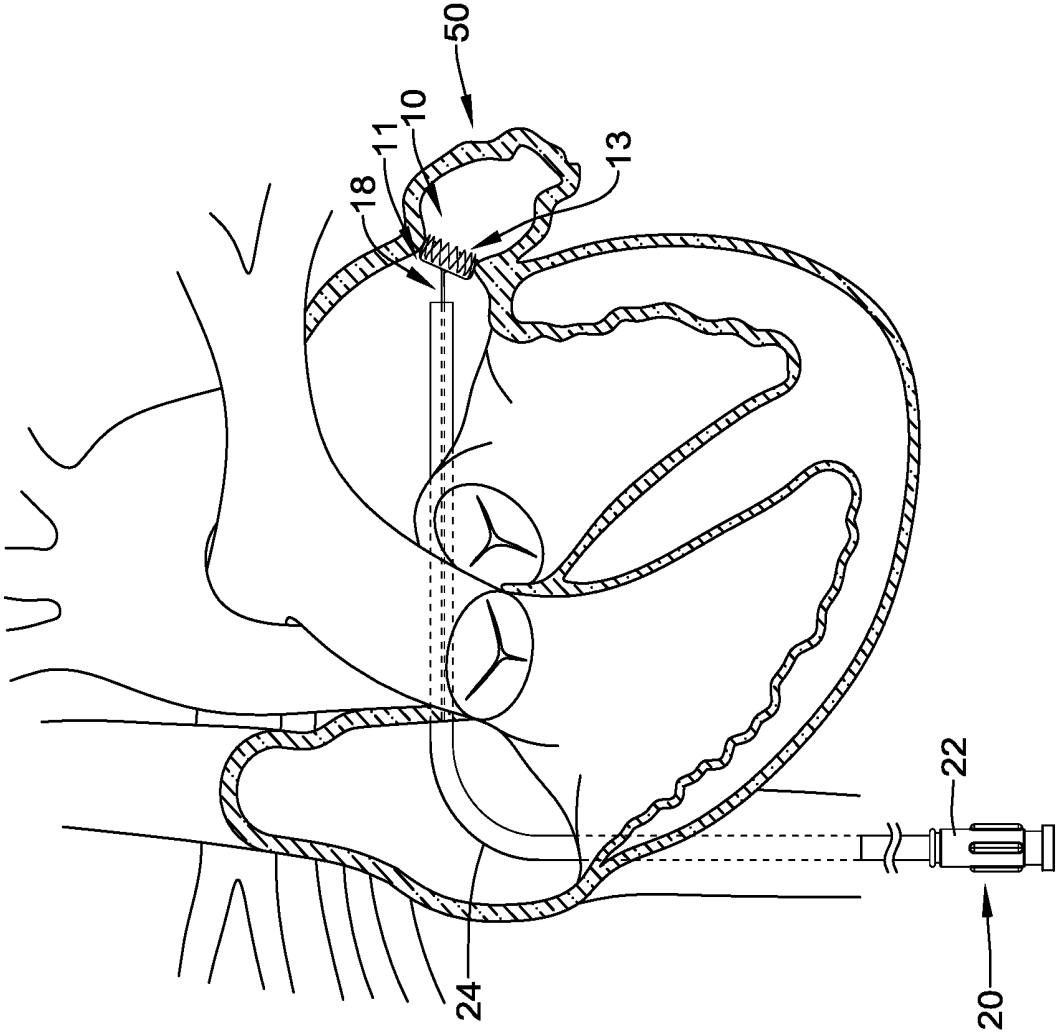

FIG. 2

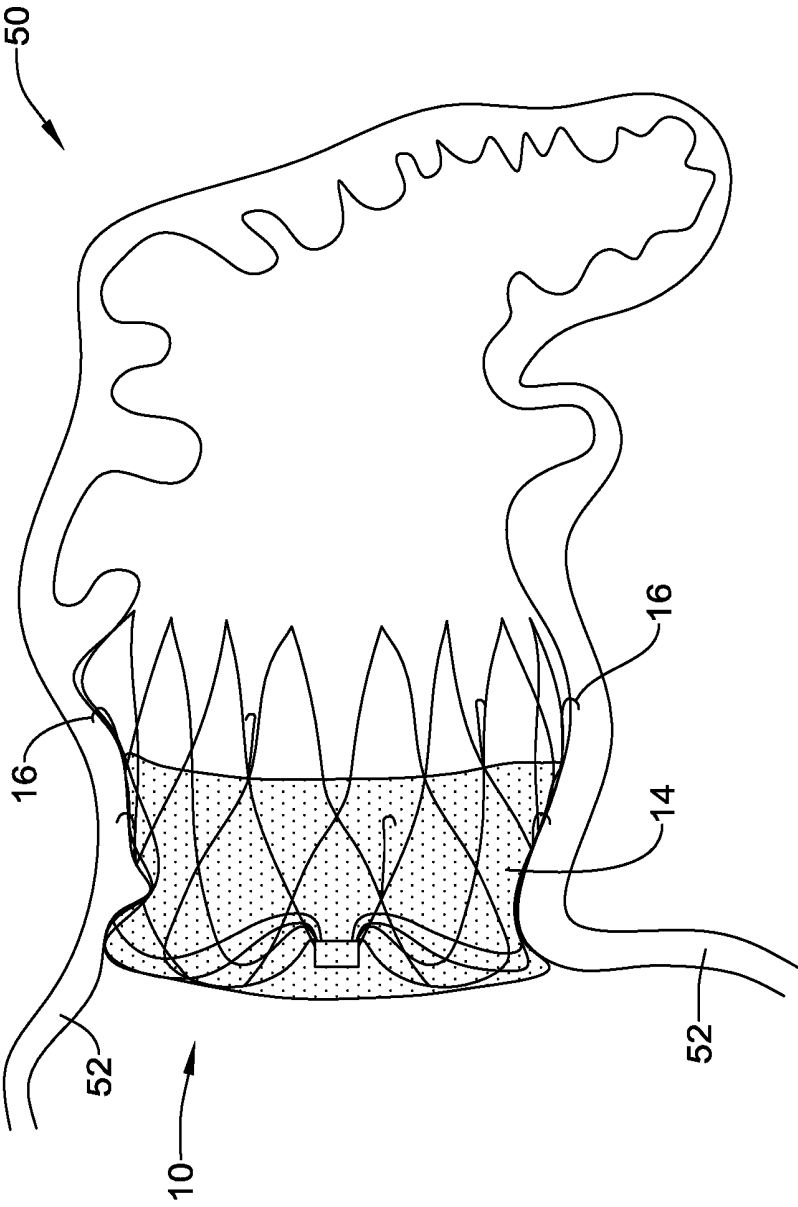

FIG. 3

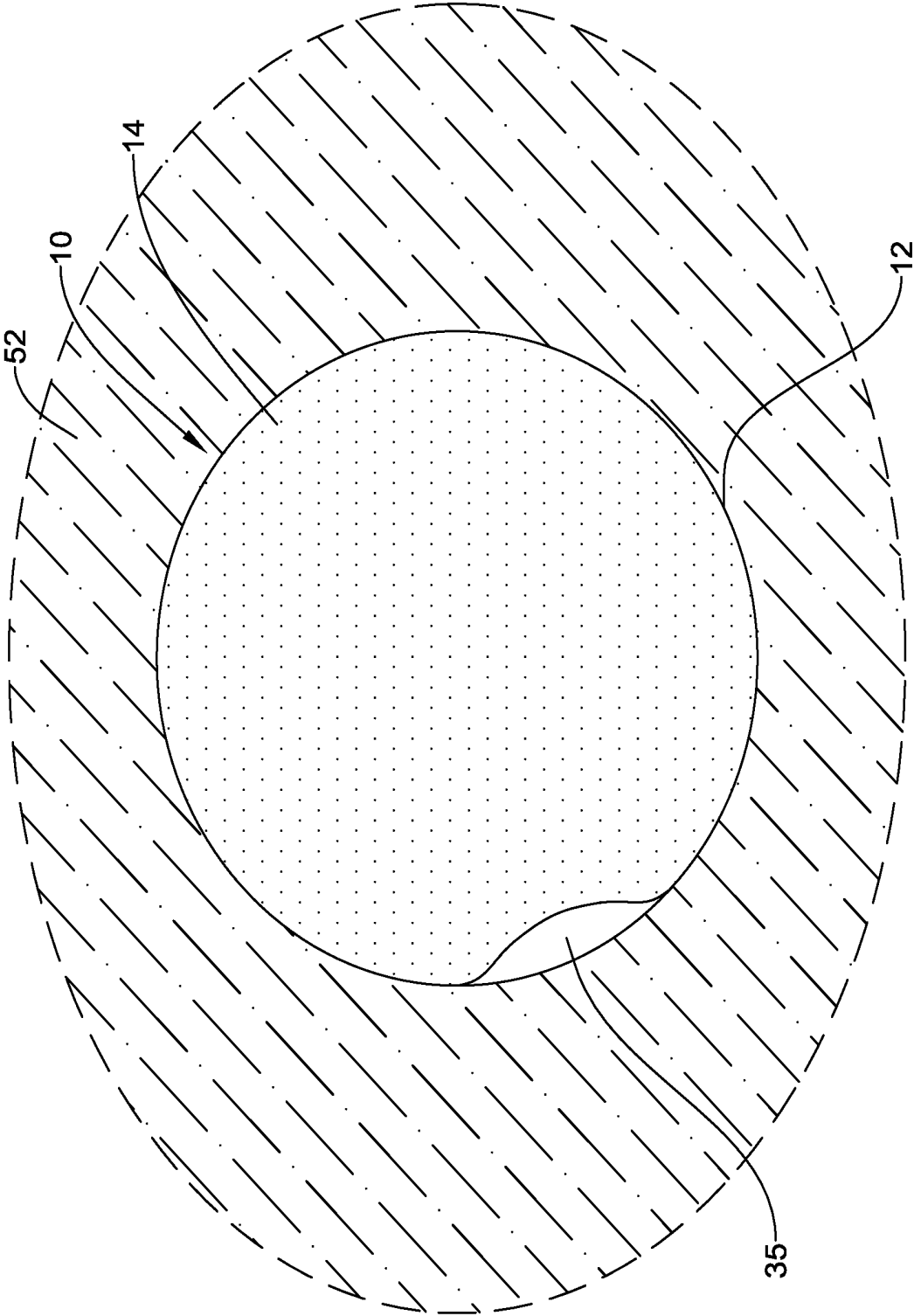

FIG. 4

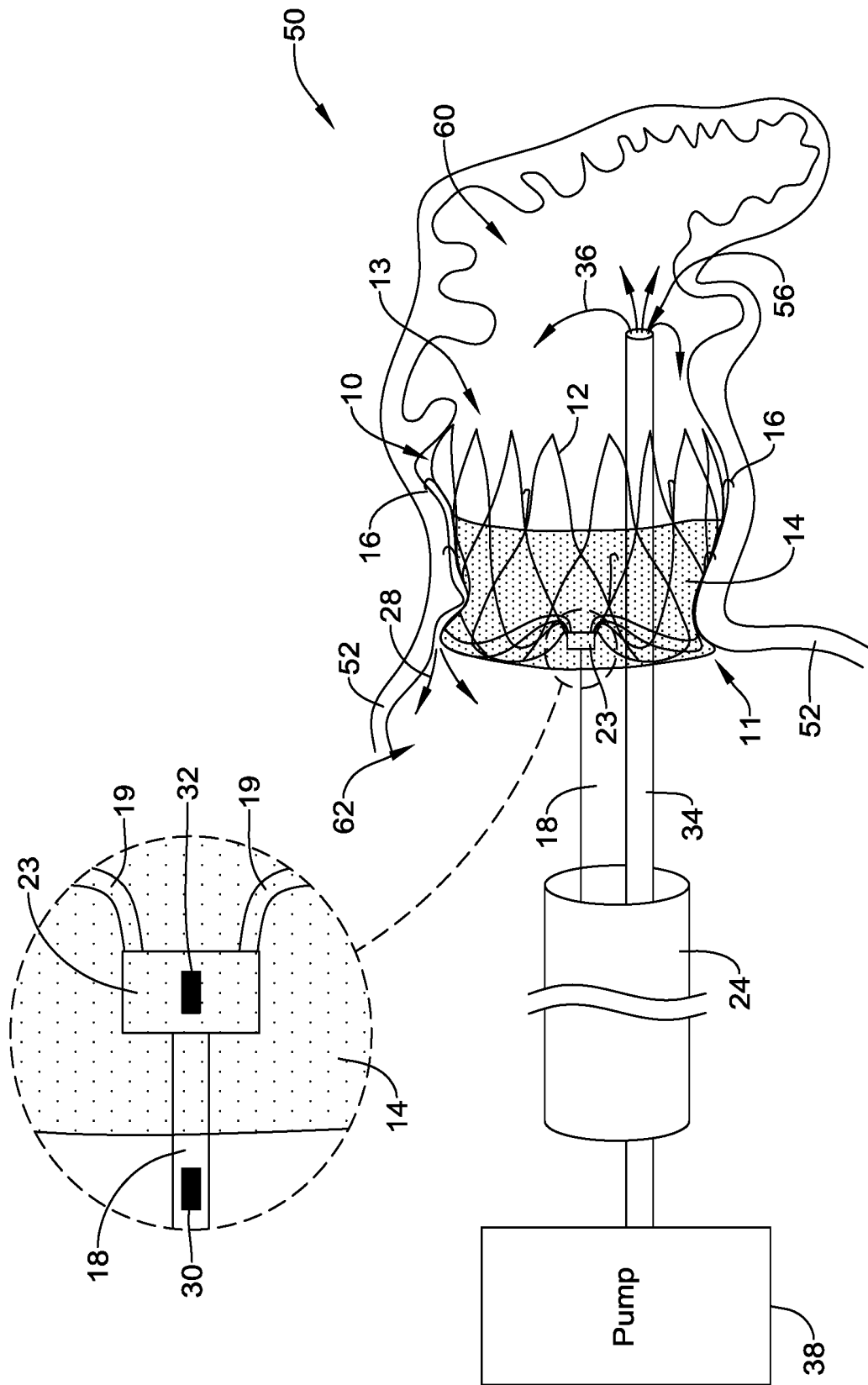

FIG. 5

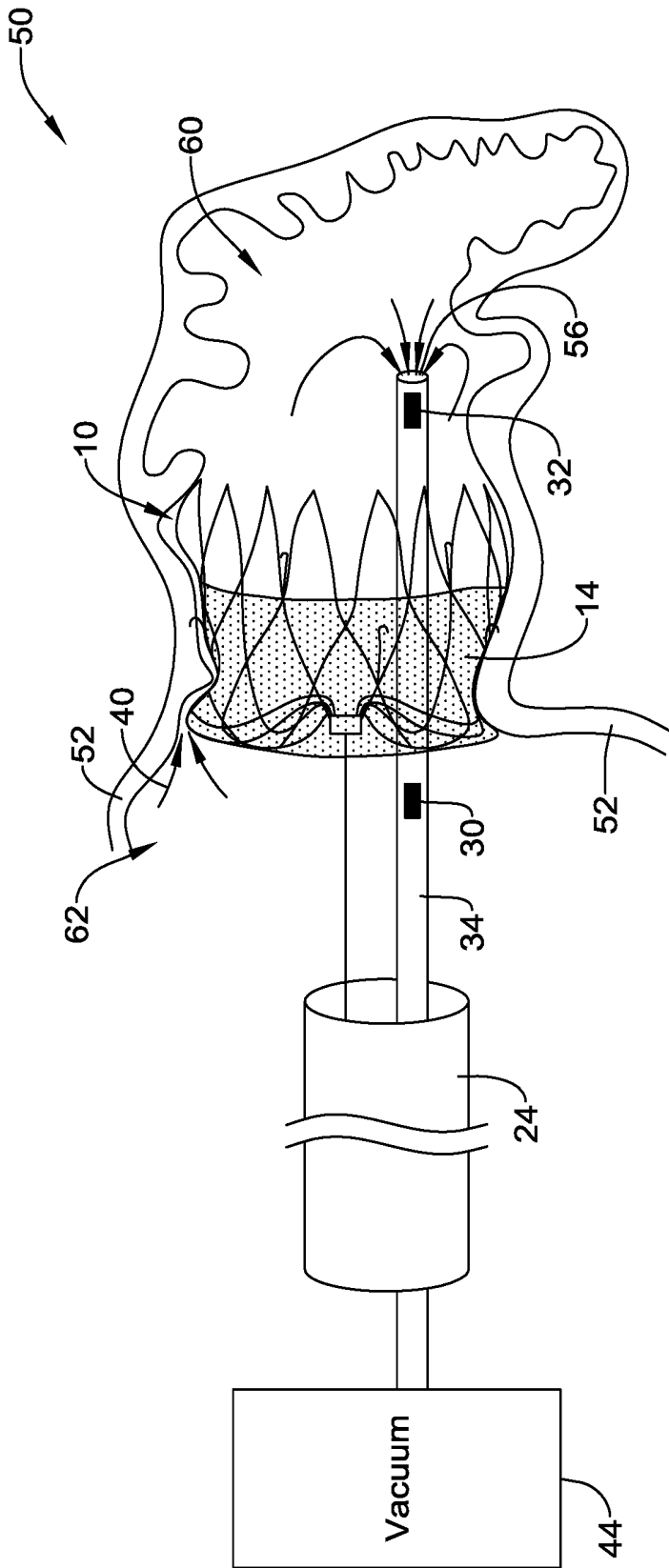

FIG. 6

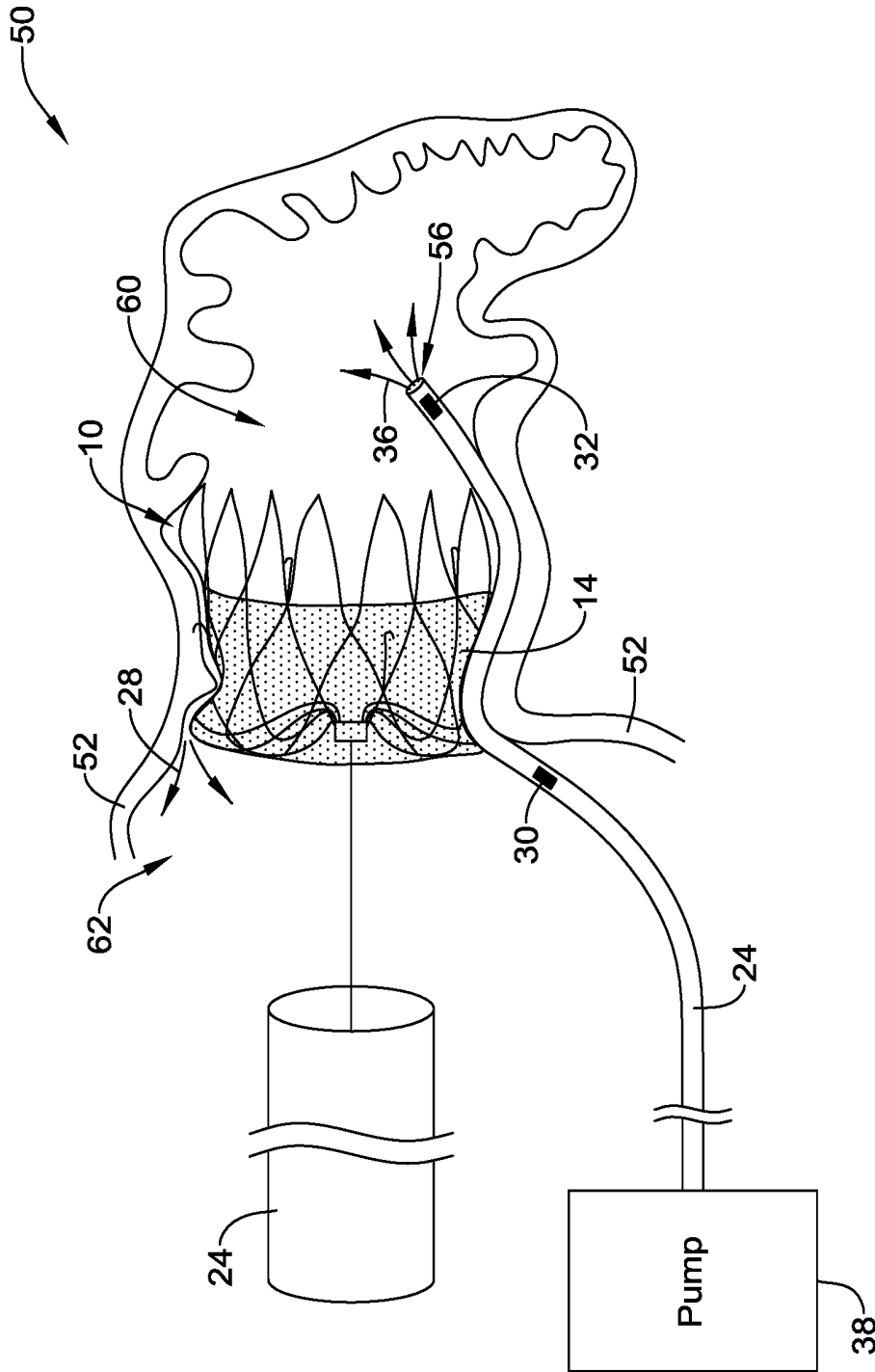

FIG. 7

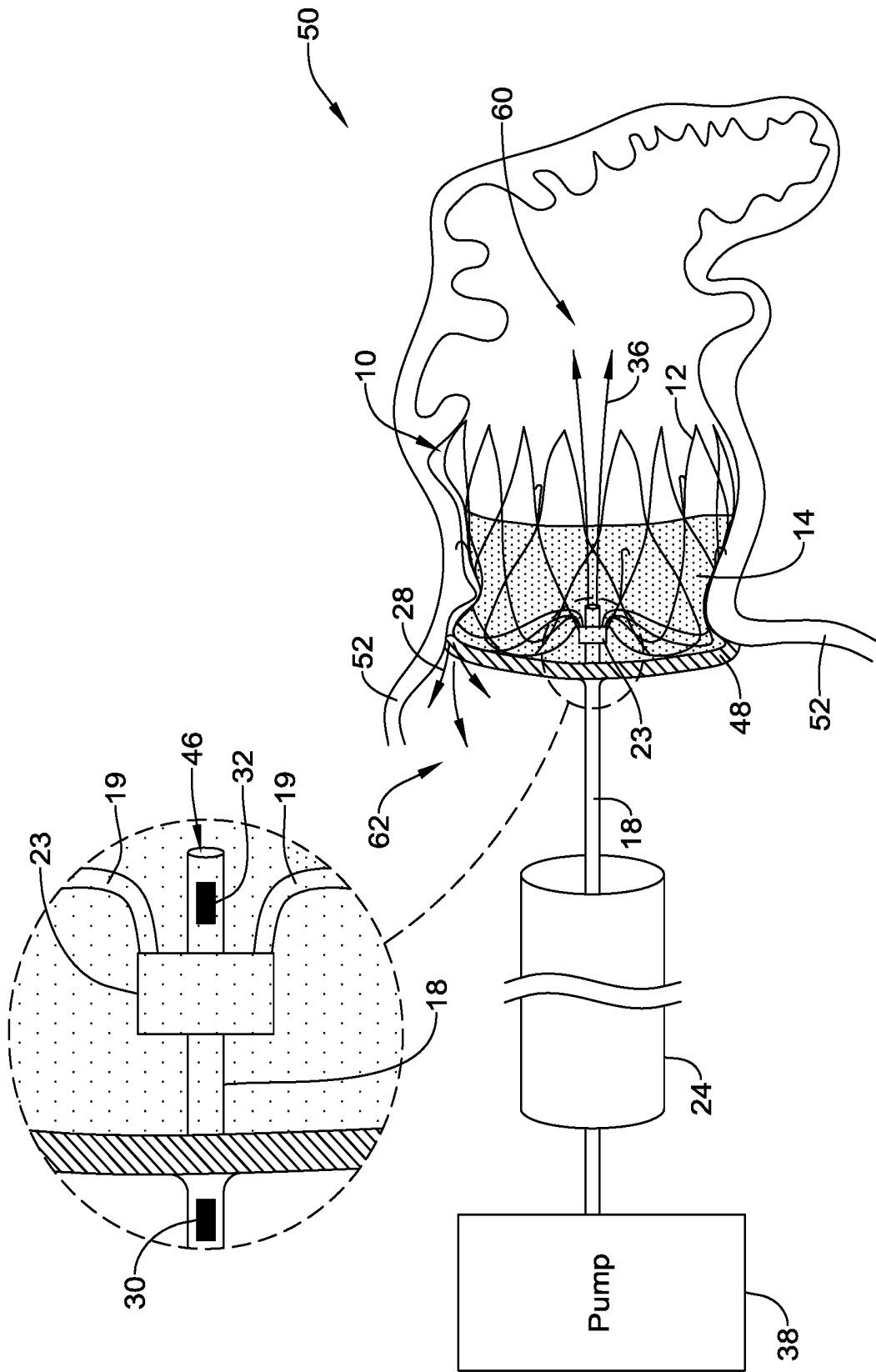

FIG. 8

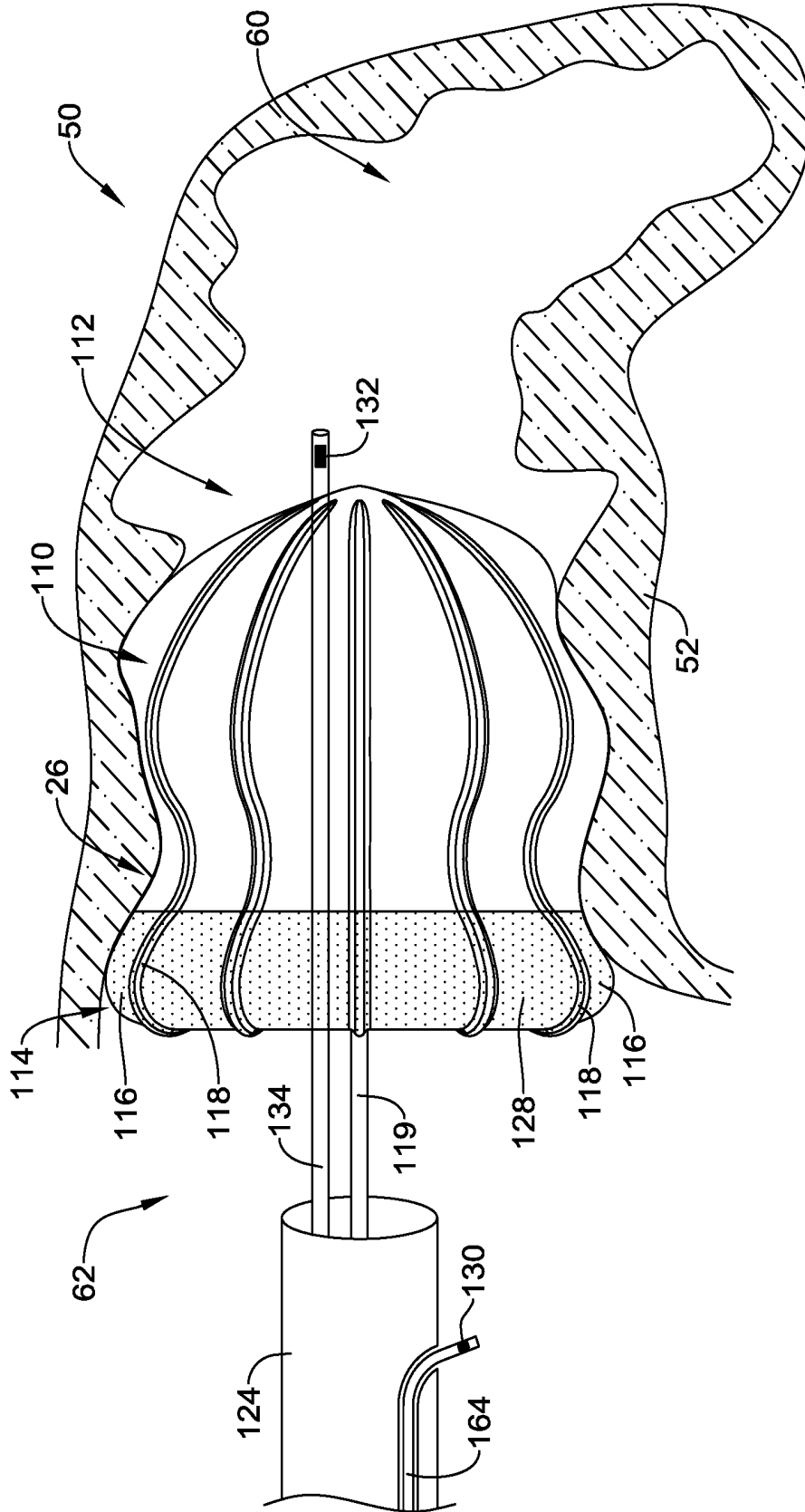

FIG. 9

## OCCLUSIVE SEALING SENSOR SYSTEM

### CROSS-REFERENCE TO RELATED APPLICATIONS

[0001] This application claims the benefit of priority under 35 U.S.C. § 119 to U.S. Provisional Application Ser. No. 62/665,830, filed May 2, 2018, the entirety of which is incorporated herein by reference.

### BACKGROUND

[0002] The left atrial appendage (LAA) is a small organ attached to the left atrium of the heart as a pouch-like extension. In patients suffering from atrial fibrillation, the left atrial appendage may not properly contract with the left atrium, causing stagnant blood to pool within its interior, which can lead to the undesirable formation of thrombi within the left atrial appendage. Thrombi forming in the left atrial appendage may break loose from this area and enter the blood stream. Thrombi that migrate through the blood vessels may eventually plug a smaller vessel downstream and thereby contribute to stroke or heart attack. Clinical studies have shown that the majority of blood clots in patients with atrial fibrillation are found in the left atrial appendage. As a treatment, medical devices have been developed which are positioned in the left atrial appendage and deployed to close off the ostium of the left atrial appendage. Over time, the exposed surface(s) spanning the ostium of the left atrial appendage becomes covered with tissue (a process called endothelization), effectively removing the left atrial appendage from the circulatory system and reducing or eliminating the number of thrombi which may enter the blood stream from the left atrial appendage. In some instances, improper placement of the medical device in the left atrial appendage may result in an insufficient seal between the medical device and the tissue wall defining the left atrial appendage. A continuing need exists for improved medical devices and methods to detect leakage around an occlusive implant disposed in the left atrial appendage.

### SUMMARY

[0003] An example system for detecting leakage around an occlusive implant disposed in the left atrial appendage includes an elongate shaft having a port disposed at a distal end region thereof and a first sensor disposed adjacent the elongate shaft. The elongate shaft is configured to be positioned adjacent the occlusive implant such that the first sensor is positioned on a first side of the occlusive implant and the port is positioned on a second side of the occlusive implant. Further, the first sensor is configured to measure a first parameter and the first parameter is utilized to determine a fluid leak between the occlusive implant and a tissue wall defining the left atrial appendage.

[0004] In addition or alternatively, wherein the first parameter includes at least one of a fluid flowrate, a fluid pressure and a fluid temperature.

[0005] In addition or alternatively, wherein the elongate shaft is configured to inject fluid into the left atrial appendage.

[0006] In addition or alternatively, wherein the elongate shaft is configured to vacuum fluid out of the left atrial appendage.

[0007] In addition or alternatively, further comprising a core wire coupled to the occlusive implant, and wherein the first sensor is disposed on the core wire.

[0008] In addition or alternatively, further comprising a second sensor disposed on a hub of the occlusive implant.

[0009] In addition or alternatively, wherein the first sensor is attached to the elongate shaft.

[0010] In addition or alternatively, further comprising a second sensor attached to the elongate shaft on the second side of the implant.

[0011] In addition or alternatively, wherein the elongate shaft includes a core wire and a second sensor, wherein the core wire is coupled to the occlusive implant, and wherein the first sensor is disposed on the core wire on the first side of the implant, and wherein the second sensor is disposed on the core wire on the second side of the implant.

[0012] In addition or alternatively, further comprising a membrane coupled to the first side of the occlusive implant.

[0013] In addition or alternatively, wherein the membrane is configured to prevent fluid from passing therethrough.

[0014] In addition or alternatively, wherein the membrane is retractable.

[0015] In addition or alternatively, wherein the membrane includes an absorbable material.

[0016] In addition or alternatively, wherein the sensor is wireless.

[0017] Another system for detecting leakage around an occlusive implant disposed in the left atrial appendage includes:

[0018] an elongate shaft having a first sensor disposed on a first portion thereof and a second sensor disposed along a second portion thereof;

[0019] wherein the elongate shaft is configured to be positioned adjacent the occlusive implant such that the first sensor is positioned on a first side of the occlusive implant, and wherein the second sensor is positioned on a second side of the occlusive implant;

[0020] wherein the first sensor is configured to measure a first parameter;

[0021] wherein the second sensor is configured to measure a second parameter;

[0022] wherein the first parameter is compared to the second parameter to determine a fluid leak between the occlusive implant and a tissue wall defining the left atrial appendage.

[0023] In addition or alternatively, wherein the first parameter, the second parameter or both the first parameter and the second parameter include at least one of a fluid flowrate, a fluid pressure and a fluid temperature.

[0024] In addition or alternatively, wherein the elongate shaft is coupled to a hub on the occlusive implant.

[0025] In addition or alternatively, further comprising a core wire coupled to the occlusive implant.

[0026] In addition or alternatively, wherein the first sensor, the second sensor or both the first and second sensor are wireless.

[0027] A method for detecting leakage around an occlusive implant disposed in the left atrial appendage includes:

[0028] advancing an elongate shaft into the left atrial appendage, the elongate shaft including a first sensor disposed thereon and a port disposed at a distal end region thereof;

[0029] positioning the elongate shaft adjacent the occlusive implant such that the first sensor is positioned on a first

side of the occlusive implant and the port is positioned on a second side of the occlusive implant;

[0030] measuring a first parameter with the first sensor;

[0031] utilizing the first parameter to determine a fluid leak between the occlusive implant and a tissue wall defining the left atrial appendage.

[0032] The above summary of some embodiments, aspects, and/or examples is not intended to describe each embodiment or every implementation of the present disclosure. The figures and the detailed description which follows more particularly exemplify these embodiments.

#### BRIEF DESCRIPTION OF THE DRAWINGS

[0033] The disclosure may be more completely understood in consideration of the following detailed description of various embodiments in connection with the accompanying drawings, in which:

[0034] FIG. 1 is a plan view of an example occlusive implant;

[0035] FIG. 2 illustrates an example occlusive implant positioned in the heart;

[0036] FIG. 3 illustrates an example occlusive implant positioned in the left atrial appendage;

[0037] FIG. 4 illustrates an end view of an example occlusive implant positioned in the left atrial appendage;

[0038] FIG. 5 illustrates a portion of an example occlusive member sensing system;

[0039] FIG. 6 illustrates a portion of another occlusive member sensing system;

[0040] FIG. 7 illustrates a portion of another occlusive member sensing system;

[0041] FIG. 8 illustrates a portion of another occlusive member sensing system;

[0042] FIG. 9 illustrates another occlusive member sensing system.

[0043] While aspects of the disclosure are amenable to various modifications and alternative forms, specifics thereof have been shown by way of example in the drawings and will be described in detail. It should be understood, however, that the intention is not to limit aspects of the disclosure to the particular embodiments described. On the contrary, the intention is to cover all modifications, equivalents, and alternatives falling within the spirit and scope of the disclosure.

#### DETAILED DESCRIPTION

[0044] The following description should be read with reference to the drawings, which are not necessarily to scale, wherein like reference numerals indicate like elements throughout the several views. The detailed description and drawings are intended to illustrate but not limit the claimed disclosure. Those skilled in the art will recognize that the various elements described and/or shown may be arranged in various combinations and configurations without departing from the scope of the disclosure. The detailed description and drawings illustrate example embodiments of the claimed disclosure. However, in the interest of clarity and ease of understanding, while every feature and/or element may not be shown in each drawing, the feature(s) and/or element(s) may be understood to be present regardless, unless otherwise specified.

[0045] For the following defined terms, these definitions shall be applied, unless a different definition is given in the claims or elsewhere in this specification.

[0046] All numeric values are herein assumed to be modified by the term “about,” whether or not explicitly indicated. The term “about,” in the context of numeric values, generally refers to a range of numbers that one of skill in the art would consider equivalent to the recited value (e.g., having the same function or result). In many instances, the term “about” may include numbers that are rounded to the nearest significant figure. Other uses of the term “about” (e.g., in a context other than numeric values) may be assumed to have their ordinary and customary definition(s), as understood from and consistent with the context of the specification, unless otherwise specified. The recitation of numerical ranges by endpoints includes all numbers within that range, including the endpoints (e.g., 1 to 5 includes 1, 1.5, 2, 2.75, 3, 3.80, 4, and 5).

[0047] Although some suitable dimensions, ranges, and/or values pertaining to various components, features and/or specifications are disclosed, one of skill in the art, incited by the present disclosure, would understand desired dimensions, ranges, and/or values may deviate from those expressly disclosed.

[0048] As used in this specification and the appended claims, the singular forms “a”, “an”, and “the” include plural referents unless the content clearly dictates otherwise. As used in this specification and the appended claims, the term “or” is generally employed in its sense including “and/or” unless the content clearly dictates otherwise. It is to be noted that in order to facilitate understanding, certain features of the disclosure may be described in the singular, even though those features may be plural or recurring within the disclosed embodiment(s). Each instance of the features may include and/or be encompassed by the singular disclosure(s), unless expressly stated to the contrary. For simplicity and clarity purposes, not all elements of the disclosure are necessarily shown in each figure or discussed in detail below. However, it will be understood that the following discussion may apply equally to any and/or all of the components for which there are more than one, unless explicitly stated to the contrary. Additionally, not all instances of some elements or features may be shown in each figure for clarity.

[0049] Relative terms such as “proximal”, “distal”, “advance”, “retract”, variants thereof, and the like, may be generally considered with respect to the positioning, direction, and/or operation of various elements relative to a user/operator/manipulator of the device, wherein “proximal” and “retract” indicate or refer to closer to or toward the user and “distal” and “advance” indicate or refer to farther from or away from the user. In some instances, the terms “proximal” and “distal” may be arbitrarily assigned in an effort to facilitate understanding of the disclosure, and such instances will be readily apparent to the skilled artisan. Other relative terms, such as “upstream”, “downstream”, “inflow”, and “outflow” refer to a direction of fluid flow within a lumen, such as a body lumen, a blood vessel, or within a device.

[0050] The term “extent” may be understood to mean a greatest measurement of a stated or identified dimension, unless the extent or dimension in question is preceded by or identified as a “minimum”, which may be understood to mean a smallest measurement of the stated or identified

dimension. For example, “outer extent” may be understood to mean a maximum outer dimension, “radial extent” may be understood to mean a maximum radial dimension, “longitudinal extent” may be understood to mean a maximum longitudinal dimension, etc. Each instance of an “extent” may be different (e.g., axial, longitudinal, lateral, radial, circumferential, etc.) and will be apparent to the skilled person from the context of the individual usage. Generally, an “extent” may be considered a greatest possible dimension measured according to the intended usage, while a “minimum extent” may be considered a smallest possible dimension measured according to the intended usage. In some instances, an “extent” may generally be measured orthogonally within a plane and/or cross-section, but may be, as will be apparent from the particular context, measured differently—such as, but not limited to, angularly, radially, circumferentially (e.g., along an arc), etc.

**[0051]** The terms “monolithic” and “unitary” shall generally refer to an element or elements made from or consisting of a single structure or base unit/element. A monolithic and/or unitary element shall exclude structure and/or features made by assembling or otherwise joining multiple discrete elements together.

**[0052]** It is noted that references in the specification to “an embodiment”, “some embodiments”, “other embodiments”, etc., indicate that the embodiment(s) described may include a particular feature, structure, or characteristic, but every embodiment may not necessarily include the particular feature, structure, or characteristic. Moreover, such phrases are not necessarily referring to the same embodiment. Further, when a particular feature, structure, or characteristic is described in connection with an embodiment, it would be within the knowledge of one skilled in the art to effect the particular feature, structure, or characteristic in connection with other embodiments, whether or not explicitly described, unless clearly stated to the contrary. That is, the various individual elements described below, even if not explicitly shown in a particular combination, are nevertheless contemplated as being combinable or arrangeable with each other to form other additional embodiments or to complement and/or enrich the described embodiment(s), as would be understood by one of ordinary skill in the art.

**[0053]** For the purpose of clarity, certain identifying numerical nomenclature (e.g., first, second, third, fourth, etc.) may be used throughout the description and/or claims to name and/or differentiate between various described and/or claimed features. It is to be understood that the numerical nomenclature is not intended to be limiting and is exemplary only. In some embodiments, alterations of and deviations from previously-used numerical nomenclature may be made in the interest of brevity and clarity. That is, a feature identified as a “first” element may later be referred to as a “second” element, a “third” element, etc. or may be omitted entirely, and/or a different feature may be referred to as the “first” element. The meaning and/or designation in each instance will be apparent to the skilled practitioner.

**[0054]** The occurrence of thrombi in the left atrial appendage (LAA) during atrial fibrillation may be due to stagnancy of blood pooling in the LAA. The pooled blood may still be pulled out of the left atrium by the left ventricle, however less effectively due to the irregular contraction of the left atrium caused by atrial fibrillation. Therefore, instead of an active support of the blood flow by a contracting left atrium and left atrial appendage, filling of the left ventricle may

depend primarily or solely on the suction effect created by the left ventricle. However, the contraction of the left atrial appendage may not be in sync with the cycle of the left ventricle. For example, contraction of the left atrial appendage may be out of phase up to 180 degrees with the left ventricle, which may create significant resistance to the desired flow of blood. Further still, most left atrial appendage geometries are complex and highly variable, with large irregular surface areas and a narrow ostium or opening compared to the depth of the left atrial appendage. These aspects as well as others, taken individually or in various combinations, may lead to high flow resistance of blood out of the left atrial appendage.

**[0055]** In an effort to reduce the occurrence of thrombi formation within the left atrial appendage and prevent thrombi from entering the blood stream from within the left atrial appendage, it may be desirable to develop medical devices and/or occlusive implants that close off the left atrial appendage from the heart and/or circulatory system, thereby lowering the risk of stroke due to thromboembolic material entering the blood stream from the left atrial appendage. However, in some instances one or more factors (e.g., improper placement, improper sizing, irregular-shaped left atrial appendage, etc.) may result in improper sealing of the occlusive implant along the tissue wall defining the left atrial appendage. Example medical devices and/or occlusive implants which detect leakage around an occlusive implant disposed in the left atrial appendage are disclosed. FIG. 1 illustrates an example occlusive implant **10**. The occlusive implant **10** may include an expandable framework **12**. The expandable framework **12** may include a proximal end region **11** and a distal end region **13**. FIG. 1 further illustrates that the expandable framework **12** may include one or more projections **17** extending in a proximal-to-distal direction. In some instances (such as that shown in FIG. 1), plurality of projections **17** may extend circumferentially around a longitudinal axis **53** of the expandable framework **12**. In other words, in some examples the projections **17** may resemble the peaks of a “crown” extending circumferentially around a longitudinal axis **53** of the expandable framework **12**. While the above discussion (and the illustration shown in FIG. 1), shows a plurality of projections **17**, it is contemplated that the occlusive implant **10** may include 1, 2, 3, 4, 5, 6, 7, 8, 9, 10, 11, 12 or more individual projections **17** disposed in a variety of arrangements along the expandable framework **12**.

**[0056]** Additionally, FIG. 1 illustrates that the proximal end region **11** of the expandable framework **12** may include a plurality of support members **19** extending circumferentially around the longitudinal axis **53** of the expandable framework **12**. FIG. 1 illustrates that that plurality of support members **19** may include one or more curved portions which are shaped such that they define a “recess” **21** extending distally into the expandable framework **12**. As illustrated in FIG. 1, the recess **21** may extend circumferentially around the longitudinal axis **53**. Further, FIG. 1 illustrates that each of the plurality of support members **19** may include a first end **25** which is attached to a central hub **23**. It can be appreciated that the central hub **23** may be aligned along the longitudinal axis **53** of the expandable framework **12**. FIG. 1 illustrates that the hub **23** may be positioned such that it lies within the recess **21** defined by the plurality of support members **19**.

**[0057]** The occlusive implant **10** may also include a first occlusive member **14** disposed on, disposed over, disposed about, or covering at least a portion of the expandable framework **12**. In some embodiments, the first occlusive member **14** may be disposed on, disposed over, disposed about or cover at least a portion of an outer (or outwardly-facing) surface of the expandable framework **12**. FIG. 1 further illustrates that the first occlusive member **14** may extend only partially along the longitudinal extent of the expandable framework **12**. However, this is not intended to be limiting. Rather, the first occlusive member **14** may extend along the longitudinal extent of the expandable framework **12** to any degree (e.g., the full longitudinal extent of the expandable framework **12**).

**[0058]** In some embodiments, the occlusive member **14** may be permeable or impermeable to blood and/or other fluids, such as water. In some embodiments, the occlusive member **14** may include a woven, braided and/or knitted material, a fiber, a sheet-like material, a fabric, a polymeric membrane, a metallic or polymeric mesh, a porous filter-like material, or other suitable construction. In some embodiments, the occlusive member **14** may prevent thrombi (i.e. blood clots, etc.) from passing through the occlusive member **14** and out of the left atrial appendage into the blood stream. In some embodiments, the occlusive member **14** may promote endothelialization after implantation, thereby effectively removing the left atrial appendage from the patient's circulatory system. Some suitable, but non-limiting, examples of materials for the occlusive member **14** are discussed below.

**[0059]** FIG. 1 further illustrates that the expandable framework **12** may include a plurality of anchor members **16** disposed about a periphery of the expandable framework **12**. The plurality of anchor members **16** may extend radially outward from the expandable framework **12**. In some embodiments, at least some of the plurality of anchor members **16** may each have and/or include a body portion and a tip portion projecting circumferentially therefrom, as shown in FIG. 1. Some suitable, but non-limiting, examples of materials for the expandable framework **12** and/or the plurality of anchor members **16** are discussed below.

**[0060]** In some examples, the expandable framework **12** and the plurality of anchor members **16** may be integrally formed and/or cut from a unitary member. In some embodiments, the expandable framework **12** and the plurality of anchor members **16** may be integrally formed and/or cut from a unitary tubular member and subsequently formed and/or heat set to a desired shape in the expanded configuration. In some embodiments, the expandable framework **12** and the plurality of anchor members **16** may be integrally formed and/or cut from a unitary flat member, and then rolled or formed into a tubular structure and subsequently formed and/or heat set to the desired shape in the expanded configuration. Some exemplary means and/or methods of making and/or forming the expandable framework **12** include laser cutting, machining, punching, stamping, electro discharge machining (EDM), chemical dissolution, welding, etc. Other means and/or methods are also contemplated.

**[0061]** As illustrated in FIG. 1, the plurality of anchor members **16** disposed along the expandable framework **12** may include two rows of anchor members **16**. However, this is not intended to be limiting. Rather, the expandable framework **12** may include a single row of anchor members **16**. In

other examples, the expandable framework **12** may include more than two rows of anchor members **16**. For example, in some instances the expandable framework **12** may include 1, 2, 3, 4 or more rows of anchor members **16**.

**[0062]** FIG. 2 illustrates an example occlusive implant **10** positioned within the left atrial appendage **50**. FIG. 2 further illustrates that the occlusive implant **10** may be inserted and advanced through a body lumen via an occlusive implant delivery system **20**. In some instances, an occlusive implant delivery system **20** may include a delivery catheter **24** which is guided toward the left atrium via various chambers and lumens of the heart (e.g., the inferior vena cava, superior vena cava, the right atrium, etc.) to a position adjacent the left atrial appendage **50**. In some examples, the occlusive implant **10** may be configured to shift between a collapsed configuration and an expanded configuration. For example, in some instances, the occlusive implant **10** may be in a collapsed configuration during delivery via an occlusion implant delivery system, whereby the occlusive implant **10** expands to an expanded configuration once deployed from the occlusion implant delivery system **20**.

**[0063]** The delivery system **20** may include a hub member **22** coupled to a proximal region of the delivery catheter **24**. The hub member **22** may be manipulated by a clinician to direct the distal end region of the delivery catheter **24** to a position adjacent the left atrial appendage **50**. In some embodiments, an occlusive implant delivery system may include a core wire **18**. In some examples, the core wire **18** may be a solid member. However, in other examples the core wire **18** may include a lumen (it is noted that the lumen of the core wire **18** is not shown in FIG. 2). As will be discussed below, in some examples the core wire **18** may be designed such that a fluid may be passed through a lumen extending therewithin. Further, a proximal end **11** of the expandable framework **12** may be configured to releasably attach, join, couple, engage, or otherwise connect to the distal end of the core wire **18**. In some embodiments, an end region of the expandable framework **12** may include a threaded insert coupled thereto. In some embodiments, the threaded insert may be configured to and/or adapted to couple with, join to, mate with, or otherwise engage a threaded member disposed at the distal end of a core wire **18**. Other means of releasably coupling and/or engaging the proximal end of the expandable framework **12** to the distal end of the core wire **18** are also contemplated.

**[0064]** FIG. 2 further illustrates that the distal end region **13** of the expandable framework **12** may extend farther into the left atrial appendage **50** as compared to the proximal end region **11** of the expandable framework **12**. It can be appreciated that as the expandable framework **12** is advanced into the left atrial appendage **50**, the distal end region **13** may engage with tissue defining the left atrial appendage **50**. In other words, in some examples the distal end region **13** may be considered the "leading" region of the expandable framework **12** as it enters into the left atrial appendage **50**. However, this is not intended to be limiting. Rather, in some examples the proximal end region **11** may be considered the "leading" region of the expandable framework **12** as it enters into the left atrial appendage **50**.

**[0065]** FIG. 3 illustrates the example occlusive implant **10** positioned within the left atrial appendage **50**. Additionally, FIG. 3 illustrates that the expandable framework **12** may be compliant and, therefore, substantially conform to and/or be in sealing engagement with the shape and/or geometry of a

lateral wall of a left atrial appendage **50** in the expanded configuration. In some embodiments, the occlusive implant **10** may expand to a size, extent, or shape less than or different from a maximum unconstrained extent, as determined by the surrounding tissue **52** and/or lateral wall of the left atrial appendage. Additionally, FIG. **3** illustrates that the expandable framework **12** may be held fixed adjacent to the left atrial appendage by one or more anchoring members **16**.

[0066] Further, it can be appreciated that the elements of the expandable framework **12** may be tailored to increase the flexibility and compliance of the expandable framework **12** and/or the occlusive implant **10**, thereby permitting the expandable framework **12** and/or the occlusive implant **10** to conform to the tissue around it, rather than forcing the tissue to conform to the expandable framework **12** and/or the occlusive implant **10**. Additionally, in some instances, it may be desirable to design the occlusive implant **10** discussed above to include various features, components and/or configurations which improve the sealing capabilities of the occlusive implant **10** within the left atrial appendage. Several example occlusion devices including various sealing features are disclosed below.

[0067] However, in some instances one or more factors (e.g., improper placement, improper sizing, irregular-shaped left atrial appendage, etc.) may result in improper sealing of the occlusive implant **10** along the tissue wall defining the left atrial appendage **50**. For example, in some instances the occlusive implant **10** may not conform to the tissue around it, whereby a gap forms between the occlusive implant **10** and the tissue wall defining the left atrial appendage.

[0068] For example, FIG. **4** illustrates the occlusive implant **10** positioned within the left atrial appendage **50** (described above). The positioning of the occlusive implant **10** shown in FIG. **4** is similar to that shown in FIG. **3**, however, FIG. **4** illustrates an alternate view of the occlusive implant **10**. In particular, FIG. **4** illustrates an end view of the occlusive implant **10** positioned in the left atrial appendage **50** (e.g., a view of the bottom of the occlusive device **10** looking inward at the left atrial appendage **50**). FIG. **4** illustrates the occlusive member **14** spanning the proximal (e.g., left atrium facing) portion of the framework **12**. Further, FIG. **4** illustrates that the occlusive member **14** may extend across the proximal portion of the framework **12** to a position where it contacts tissue **52** which is surrounding the left atrial appendage **50**. It can be appreciated from FIG. **4** that the occlusive member **14** may extend circumferentially around the entire opening of the left atrial appendage. In other words, a portion of the occlusive member **14** may be positioned adjacent to the surrounding tissue **52** which is adjacent to the left atrial appendage (e.g., positioned around the circumference of the opening to the left atrial appendage **50**).

[0069] However, while can be appreciated that the occlusive device **10** may be able to conform to the specific shape and/or geometry of a lateral wall of a left atrial appendage **50**, FIG. **4** illustrates that in some instances a gap **35** may form between the occlusive implant **10** and the surrounding tissue **52** defining the left atrial appendage **50**. In other words, the occlusive device **10** may not entirely fill and/or conform to the specific shape and/or geometry of a lateral wall of a left atrial appendage **50** when positioned adjacent thereto, resulting in a gap **35**.

[0070] As discussed above, it may be desirable to detect leakage which may occur around an improperly sealed left

occlusive implant. It can be appreciated that being able to identify leakage around an occlusive implant may allow a clinician to reposition the implant and seal off the leaking fluid. Alternatively, a clinician may opt to retrieve an occlusive implant which has been improperly positioned.

[0071] FIG. **5** illustrates an example system and methodology for detecting fluid leakage around an occlusive implant **10**. FIG. **5** illustrates the example occlusive implant **10** (including the framework **12** and the occlusive member **14**) positioned within the left atrial appendage **50**. FIG. **5** further illustrates that the distal end region **13** of the occlusive implant **10** extending farther into the left atrial appendage **50** as compared to the proximal end region **11** of the occlusive implant **10**. Additionally, FIG. **5** illustrates that the occlusive implant **10** may be compliant and, therefore, substantially conform to and/or be in sealing engagement with the shape and/or geometry of a lateral wall of a left atrial appendage **50** in the expanded configuration. In some embodiments, the occlusive implant **10** may expand to a size, extent, or shape less than or different from a maximum unconstrained extent, as determined by the surrounding tissue **52** and/or lateral wall of the left atrial appendage **50**. Additionally, FIG. **5** illustrates that the occlusive implant **10** may be held fixed adjacent to the left atrial appendage **50** by one or more anchoring members **16**.

[0072] Additionally, FIG. **5** illustrates that the example occlusive implant **10** may be coupled to a core wire **18**. As illustrated in the detailed view of FIG. **5**, the core wire **18** may be attached to the occlusive implant **10** via the central hub **23**. Further, the detailed view of FIG. **5** illustrates the support members **19** of the framework **12** attached to the central hub **23**. The detailed view of FIG. **5** further illustrates a first sensor **30** positioned along a portion of the core wire **18**. Further, the detailed view of FIG. **5** further illustrates a second sensor **32** disposed along a portion of the central hub **23**. It is noted that the examples described herein that include two sensors are not intended to be limiting. Rather, it is contemplated that any of the examples described herein may include more or less than two sensors. For example, the examples may include 1, 2, 3, 4, 5, 6 or more sensors.

[0073] Further, the arrangement of the first sensor **30** and the second sensor **32** shown in FIG. **5** (or any of the figures herein) is merely exemplary and not intended to be limiting. Rather, it is contemplated that the first sensor **30** and/or the second sensor **32** may be positioned and/or arranged along other portions of the core wire **18**, the central hub **23**, the framework **12** and/or the occlusive member **14**. For example, it is contemplated that both the first sensor **30** and the second sensor **32** may each be positioned on the core wire **18**. Additionally, it is contemplated that any of the sensors disclosed herein may be fully or partially embedded within any of the components (e.g., implants, core wires, catheters, expandable members, wires, etc.) described herein.

[0074] The first sensor **30** and/or the second sensor **32** may be designed to sense, measure, collect, record, etc. one or more parameters related to the flow of fluid (e.g., blood) adjacent to the occlusive implant **10** and/or the left atrial appendage **50**. For example, the first sensor **30** and/or the second sensor **32** may be designed to sense, measure, collect and/or record fluid flowrates, fluid pressures, fluid temperature, etc. Any of the sensors described herein (including the first sensor **30** and/or the second sensor **32**) may include flow rates sensors, pressure sensors (e.g., piezoelectric sensors,

Fiber Bragg sensors, optical pressure sensors, passive pressure sensors, etc.), temperature sensors, etc. It is contemplated that any of the sensors described herein (including the first sensor 30 and/or the second sensor 32) may be able to sense, measure, collect and/or record a combination of different parameters (e.g., a combination of fluid flowrates, fluid pressures, fluid temperature, etc.).

[0075] Additionally, it is contemplated that the first sensor 30 and/or the second sensor 32 may be wired to a processor (not shown), whereby the processor may be designed to utilize the data sensed, measured and/or collected by the first sensor 30 and/or the second sensor 32 to calculate and/or compare one or more parameters (e.g., fluid flowrates, fluid pressures, fluid temperature, etc.). For example, it can be appreciated that in order to determine whether fluid is leaking around the occlusive implant 10 shown in FIG. 5, it may be desirable to measure and compare the flowrate of fluid on one side of the occlusive implant 10 to the flowrate of fluid on the opposite side of the occlusive implant 10.

[0076] For example, provided that the occlusive implant 10 was properly placed along the opening to the left atrial appendage 50 such that no gaps existed between the occlusive implant 10 and the surrounding tissue 52 (as described above), the occlusive member 14 may substantially prevent fluid from flowing out of the left atrial appendage 50 and into the left atrium. Accordingly, it can be appreciated that the fluid flux between a properly sealed left atrial appendage 50 and the left atrium may be approximately zero (as no fluid would be flowing out any gaps between the occlusive implant 10 and the surrounding tissue 52). It is noted that the area inside the left atrial appendage 50 is denoted by the reference numeral "60" in FIG. 5. The inside portion of the left atrial appendage 50 as contemplated herein may be defined as that portion of the left atrial appendage 50 bounded by the inner, concave surface of the occlusive implant 10. This is in contrast to the area "outside" the left atrial appendage 50 which is denoted by the reference numeral "62" in FIG. 5. Further, "outside" the left atrial appendage 50 as contemplated herein may be defined as that portion of the left atrium located outside the outer, convex surface of the occlusive implant 10. In some examples, the occlusive member 14 may define the boundary between a fluid positioned inside the left atrial appendage 50 and the left atrium.

[0077] If a gap exists between the occlusive implant 10 and the surrounding tissue 52, it can be appreciated that fluid may flow from inside the left atrial appendage 50 to a location within the left atrium. Accordingly, the presence of leakage around the occlusive implant 10 may be detected by measuring a first parameter (e.g., a first fluid flowrate, a first fluid pressure, etc.) outside of the occlusive implant 10 and comparing it a second parameter (e.g., a second fluid flowrate, a second fluid pressure, etc.) on the inside of the occlusive implant 10. The difference between the first parameter value and the second parameter value may not only provide an indication of the presence of fluid leakage around the occlusive implant 10, but may also provide an indication of the degree (e.g., volumetric flow rate) of fluid leaking around the occlusive implant 10.

[0078] To that end, in any of the examples disclosed herein, it may be beneficial to pump a fluid (e.g., saline) inside a deployed occlusive implant 10 in order to more easily detect a potential fluid leakage point through a gap between the occlusive implant 10 and the surrounding tissue

52. In some examples, the fluid may be pumped in a series of pulses (e.g., transient bolus injection). However, in other examples, the fluid may be pumped as a steady-state fluid flow. Further, or examples may include passive measurement of the blood pressure absent a pumping mechanism. FIG. 5 illustrates an example catheter 34 extending within a delivery catheter 24 (FIG. 5 also shows the core wire 18 extending within the delivery catheter 24). Further, the catheter 34 may include a distal end region, a proximal end region and a lumen extending therein. As shown in FIG. 5, the proximal end region of the catheter 34 may be coupled to a pump 38.

[0079] FIG. 5 further illustrates that the catheter 34 may extend through the occlusive implant 10 such that the distal end region of the catheter 34 may be positioned inside the left atrial appendage 50. Further, FIG. 5 illustrates that fluid 36 may be pumped through a distal port 56 of the catheter 34 into the inside 60 of the left atrial appendage 50. For illustrative purposes, FIG. 5 shows fluid 28 leaking from one side of the occlusive implant 10 (e.g., from the inside area 60) to the other side of the occlusive implant 10 (e.g., to an area 62 within the left atrium).

[0080] As described above, it can be appreciated that the first sensor 30 may be utilized to measure a first parameter (e.g., a first fluid flowrate, a first fluid pressure, etc.) on the outside of the occlusive implant 10, while the second sensor 32 may be utilized to measure a second parameter (e.g., a second fluid flowrate, a second fluid pressure, etc.) on the inside of the occlusive implant 10. As discussed above, comparison of the parameter measurements (or parameters calculated based upon the collected first parameter and the second parameter) may be utilized to determine the presence and extent of fluid leakage around the occlusive implant 10.

[0081] Additionally, it is contemplated that any of the sensors described herein may be positioned externally to the body. For example, in some instances it may be desirable to position one or more sensors adjacent to the pump 38 and/or any other structure located on the outside of a patient's body. Positioning one or more sensors outside of a patient's body may be beneficial because the complexity of the system may be reduced. Furthermore, externally-positioned sensors may be reused whereas sensors inside the body may be single-use (due to sterilization, for example).

[0082] Further, as described above, using parameters measured at the pump orifice or inside the pump (e.g., volumetric flowrate, pressure, etc.), a leak may be calculated without having sensors inside the body by any means. It is also noted that external sensor readings may be coupled with internal sensor readings. For example, the pump may measure flow rate externally while one or more pressures (or temperatures, etc.) may be measured internally on the implant or catheter.

[0083] Additionally, it can be appreciated that the parameters discussed above (e.g., fluid flowrate, volumetric flowrate, fluid pressure, etc.) may vary with time. Therefore, changes in the parameters over time may provide additional information regarding the effective seal provided by the occlusive implant 10. For example, if the pump flow rate is held constant and the observed (e.g., measured, sensed) pressure inside the left atrial appendage 50 rises quasi-steadily over several heart beats, it may imply that the occlusive implant is providing a substantially effective seal. However, in another example, if the pump flowrate is held constant and the pressure rises and then becomes quasi-constant, provided that rise is negligible, it may imply that

the there is a substantial leak between the occlusive implant 10 and the surrounding tissue 52. However, if the rise is relatively large, it may imply that the occlusive implant is providing a substantially effective seal.

[0084] FIG. 6 illustrates another example of a system and methodology to detect leakage around an example occlusive implant 10. FIG. 6 shows the occlusive implant 10 positioned within the opening of the left atrial appendage 50 similarly to that described above with respect to FIG. 5. For example, FIG. 6 illustrates that the catheter 34 may extend through the occlusive implant 10 such that the distal end region of the catheter 34 may be positioned inside the left atrial appendage 50. Additionally, FIG. 6 shows that in some examples, the first sensor 30 may be positioned along the catheter 34 at a location which is outside of the occlusive implant 10 and the second sensor 32 may be positioned along the distal end region of the catheter 34.

[0085] Further, FIG. 6 illustrates that the catheter 34 may be coupled to a vacuum 44. Accordingly, fluid 42 may be vacuumed into a distal port 56 of the catheter 34 from inside the left atrial appendage 50. The vacuuming of fluid into the catheter 34 from inside the left atrial appendage 50 may cause fluid to be pulled through gaps between the occlusive implant 10 and the surrounding tissue 52. For illustrative purposes, FIG. 6 shows fluid 40 leaking into the occlusive implant 10 (e.g., from the outside area 62) to the other side of the occlusive implant 10 (e.g., to an area 60 inside the occlusive implant 10). As discussed above, it can be appreciated that the first sensor 30 may be utilized to measure a first parameter (e.g., a first fluid flowrate, a first fluid pressure, etc.) on the outside of the occlusive implant 10, while the second sensor 32 may be utilized to measure a second parameter (e.g., a second fluid flowrate, a second fluid pressure, etc.) on the inside of the occlusive implant 10. As discussed above, comparison of the parameter measurements (or parameters calculated based upon the collected first parameter and the second parameter) may be utilized to determine the presence and extent of fluid leakage around the occlusive implant 10.

[0086] FIG. 7 illustrates another example of a system and methodology to detect leakage around an example occlusive implant 10. FIG. 7 shows the occlusive implant 10 positioned within the opening of the left atrial appendage 50 similarly to that described above. However, FIG. 7 illustrates the catheter 34 may extend along occlusive implant 10 (e.g., between the occlusive implant 10 and the surrounding tissue 52), whereby the distal end region of the catheter 34 may be positioned inside the left atrial appendage 50. Additionally, FIG. 7 shows that in some examples, the first sensor 30 may be positioned along the catheter 34 at a location which is outside of the occlusive implant 10 and the second sensor 32 may be positioned along the distal end region of the catheter 34.

[0087] Further, FIG. 7 illustrates that the catheter 24 may be coupled to a pump 38. Accordingly, fluid 36 may be pumped through a distal port 56 of the catheter 34 into the inside 60 of the left atrial appendage 50. For illustrative purposes, FIG. 7 shows fluid 28 leaking from one side of the occlusive implant 10 (e.g., from the inside area 60) to the other side of the occlusive implant 10 (e.g., to an area 62 within the left atrium). As discussed above, it can be appreciated that the first sensor 30 may be utilized to measure a first parameter (e.g., a first fluid flowrate, a first fluid pressure, etc.) on the outside of the occlusive implant

10, while the second sensor 32 may be utilized to measure a second parameter (e.g., a second fluid flowrate, a second fluid pressure, etc.) on the inside of the occlusive implant 10. As discussed above, comparison of the parameter measurements (or parameters calculated based upon the collected first parameter and the second parameter) may be utilized to determine the presence and extent of fluid leakage around the occlusive implant 10.

[0088] FIG. 8 illustrates another example of a system and methodology to detect leakage around an example occlusive implant 10. FIG. 8 shows the occlusive implant 10 positioned within the opening of the left atrial appendage 50 similarly to that described above. Similarly to that described above with respect to FIG. 5, FIG. 8 illustrates that the example occlusive implant 10 may be coupled to a core wire 18. The core wire 18 may be coupled to a pump 38. Additionally, as illustrated in the detailed view of FIG. 8, the core wire 18 may be attached to the occlusive implant 10 via the central hub 23. Further, the detailed view of FIG. 8 illustrates the support members 19 of the framework 12 attached to the central hub 23. The detailed view of FIG. 8 further illustrates a first sensor 30 positioned along a portion of the core wire 18. Additionally, the detailed view of FIG. 8 further illustrates a second sensor 32 disposed along a portion of the core wire 18 adjacent to the central hub 23. It should be noted that in some examples, the core wire 18 is attached to the central hub 23.

[0089] FIG. 8 further illustrates that, in some examples, a membrane 48 may be coupled to the core wire 18. The membrane 48 may extend along the outer surface of the framework 12, whereby the membrane is designed to prevent fluid from leaking out of the occlusive implant 10. In other words, in instances where the occlusive member 14 is porous, the membrane 48 may be utilized to maintain a level of pressure within the occlusive implant 10 while fluid leakage is detected via any of the methodologies described above. In some examples, the membrane 48 may be coated with a dissolvable wax, gel, sugar, salt or other similar media or compound to tailor the porosity of the membrane 48 and/or occlusive member 14. This coating may be designed to dissolve on its own or in accordance with a thermal or chemical means during and/or after leakage detection has taken place.

[0090] For example, FIG. 8 illustrates that in some instances the core wire 18 may include a lumen 46 through which fluid may be pumped. FIG. 8 further illustrates that the distal end region of the core wire 18 may extend through the occlusive implant 10 such that the distal end region of the core wire 18 may be positioned inside the left atrial appendage 50. Further, FIG. 8 illustrates that fluid 36 may be pumped through the lumen 46 of the core wire 18 into the inside portion 60 of the left atrial appendage 50. The membrane may be held in place while the fluid 36 is pumped into the left atrial appendage 50. Additionally, FIG. 8 shows fluid 28 leaking from one side of the occlusive implant 10 (e.g., from the inside area 60) to the other side of the occlusive implant 10 (e.g., to an area 62 within the left atrium).

[0091] As described above, it can be appreciated that the first sensor 30 may be utilized to measure a first parameter (e.g., a first fluid flowrate, a first fluid pressure, etc.) on the outside of the occlusive implant 10, while the second sensor 32 may be utilized to measure a second parameter (e.g., a second fluid flowrate, a second fluid pressure, etc.) on the

inside of the occlusive implant 10. As discussed above, comparison of the parameter measurements (or parameters calculated based upon the collected first parameter and the second parameter) may be utilized to determine the presence and extent of fluid leakage around the occlusive implant 10. Additionally, it is contemplated that the membrane 48 may be retracted/removed after the first parameter and second parameters are determined.

[0092] FIG. 9 illustrates another example occlusive implant 110 positioned an opening of the left atrial appendage 50. Further, FIG. 9 illustrates another example of a system and methodology to detect leakage around an example occlusive implant 110. The occlusive implant 110 may be configured to shift between a collapsed configuration and an expanded configuration. For example, in some instances, the occlusive implant 110 may be in a collapsed configuration during delivery via an occlusive device delivery system, whereby the occlusive implant 110 expands to an expanded configuration once deployed from the occlusion implant delivery system.

[0093] FIG. 9 further illustrates that the occlusive implant 110 may include a first end region 112 and a second end region 114. As will be discussed in greater detail below, the first end region 112 may include the portion of the occlusive implant 110 which extends farthest into a left atrial appendage 50, while the second end region 114 may include the portion of the occlusive implant 110 which is positioned closer to an opening of the left atrial appendage 50.

[0094] The occlusive implant 110 may include an expandable member 116. The expandable member 116 may also be referred to as an expandable balloon 116. The expandable member 116 may be formed from a highly compliant material (e.g., "inflation material") which permits the expandable member 116 to expand from a first unexpanded (e.g., deflated, collapsed, delivery) configuration to a second expanded (e.g., inflated, delivered) configuration. In some examples, the expandable member 116 may be inflated to pressures from about 1 psi to about 200 psi. It can be appreciated that the outer diameter of the occlusive implant 110 may be larger in the expanded configuration versus the unexpanded configuration. Example materials used for the inflation material may be hydrogel beads (or other semi-solid materials), saline, etc.

[0095] In some examples, the expandable member 116 may be constructed from silicone or a low-durometer polymer, however, other materials are contemplated. Additionally, the expandable member 116 may be impermeable to blood and/or other fluids, such as water. In some embodiments, the expandable member 116 may include a woven, braided and/or knitted material, a fiber, a sheet-like material, a metallic or polymeric mesh, or other suitable construction. Further, in some embodiments, the expandable member 116 may prevent thrombi (e.g., blood clots, etc.) originating in the left atrial appendage from passing through the occlusive implant 110 and into the blood stream. In some embodiments, the occlusive implant 110 may promote endothelial growth after implantation, thereby effectively removing the left atrial appendage from the patient's circulatory system. Some suitable, but non-limiting, examples of materials for the occlusive implant 110 are discussed below.

[0096] FIG. 9 further illustrates that occlusive implant 110 may include one or more spine members 118 extending along the expandable member 116 from the second end region 114 to the first end region 112. In some examples

described herein, the spine members 118 may be described as positioning members 118. FIG. 9 further illustrates that each of the individual spine members 118 may be spaced apart from adjacent spine members 118. In other words, the spacing between adjacent spine members 118 may be substantially uniform around the circumference of the expandable member 116. In some examples, the spine members 118 may include one or more materials which are stiffer, higher durometer materials than the material utilized to construct the expandable member 116. Some suitable, but non-limiting, examples of materials for the spine members 118 are discussed below.

[0097] FIG. 9 further illustrates that the occlusive implant 110 may include a coating 128. The coating 128 may extend around the circumference of the occlusive implant 110 (including both the expandable member 116 and the spine members 118). In some examples, the coating 128 may promote cellular growth along the surface thereof. For example, the coating 128 may include elements which promote endothelial growth along the surface thereof. For example, the endothelial growth elements may accelerate the ability for endothelial cellular tissue to form a seal across an opening of the left atrial appendage. In other examples, the coating 128 may include a polymer mesh (e.g., PET mesh), a woven, braided and/or knitted material, a fiber, a sheet-like material, a metallic or polymeric mesh, or other similar materials which may be coupled to the outer surface of the expandable member 116.

[0098] Additionally, FIG. 9 illustrates that the example occlusive implant 110 may be coupled to a core wire 119. Further, FIG. 9 illustrates that both the core wire 119 and a catheter 134 may extend through a delivery catheter 124. FIG. 9 also illustrates that the catheter 134 may extend along the occlusive implant 110 such that the distal end region of the catheter 134 may be positioned inside the left atrial appendage 50.

[0099] Additionally, FIG. 9 illustrates that a second catheter 164 may extend along the delivery catheter 124. For example, the delivery catheter 124 may include a second lumen through which the second catheter 164 may extend. Further, FIG. 9 illustrates that a first sensor 130 may be positioned along the catheter 164 at a location which is outside of the occlusive implant 110. Additionally, FIG. 9 shows that, in some examples, a second sensor 132 may be positioned along the distal end region of the catheter 134.

[0100] Similarly to that discussed above, it can be appreciated that the first sensor 130 (e.g., a first thermocouple) may be utilized to measure a first parameter (e.g., a first fluid temperature, a first fluid flowrate, a first fluid pressure, etc.) on the outside (e.g., from the area 62 within the left atrium) of the occlusive implant 110, while the second sensor 132 (e.g., a second thermocouple) may be utilized to measure a second parameter (e.g., a second fluid temperature, a second fluid flowrate, a second fluid pressure, etc.) on the inside (e.g., from the inside area 60) of the occlusive implant 110. As discussed above, comparison of the parameter measurements (or parameters calculated based upon the collected first parameter and the second parameter) may be utilized to determine the presence and extent of fluid leakage around the occlusive implant 110.

[0101] The materials that can be used for the various components of the occlusive implant 10 and/or occlusive implant 110 (and variations, systems or components thereof disclosed herein) and the various elements thereof disclosed

herein may include those commonly associated with medical devices. For simplicity purposes, the following discussion makes reference to the occlusive implant **10** and/or occlusive implant **110** (and variations, systems or components disclosed herein). However, this is not intended to limit the devices and methods described herein, as the discussion may be applied to other elements, members, components, or devices disclosed herein.

**[0102]** In some embodiments, the occlusive implant **10** and/or occlusive implant **110** (and variations, systems or components thereof disclosed herein) may be made from a metal, metal alloy, polymer (some examples of which are disclosed below), a metal-polymer composite, ceramics, combinations thereof, and the like, or other suitable material. Some examples of suitable metals and metal alloys include stainless steel, such as 444V, 444L, and 314LV stainless steel; mild steel; nickel-titanium alloy such as linear-elastic and/or super-elastic nitinol; other nickel alloys such as nickel-chromium-molybdenum alloys (e.g., UNS: N06625 such as INCONEL® 625, UNS: N06022 such as HASTELLOY® C-22®, UNS: N10276 such as HASTELLOY® C276®, other HASTELLOY® alloys, and the like), nickel-copper alloys (e.g., UNS: N04400 such as MONEL® 400, NICKELVAC® 400, NICORROS® 400, and the like), nickel-cobalt-chromium-molybdenum alloys (e.g., UNS: R44035 such as MP35-N® and the like), nickel-molybdenum alloys (e.g., UNS: N10665 such as HASTELLOY® ALLOY B2®), other nickel-chromium alloys, other nickel-molybdenum alloys, other nickel-cobalt alloys, other nickel-iron alloys, other nickel-copper alloys, other nickel-tungsten or tungsten alloys, and the like; cobalt-chromium alloys; cobalt-chromium-molybdenum alloys (e.g., UNS: R44003 such as ELGILOY®, PHYNOX®, and the like); platinum enriched stainless steel; titanium; platinum; palladium; gold; combinations thereof; and the like; or any other suitable material.

**[0103]** As alluded to herein, within the family of commercially available nickel-titanium or nitinol alloys, is a category designated “linear elastic” or “non-super-elastic” which, although may be similar in chemistry to conventional shape memory and super elastic varieties, may exhibit distinct and useful mechanical properties. Linear elastic and/or non-super-elastic nitinol may be distinguished from super elastic nitinol in that the linear elastic and/or non-super-elastic nitinol does not display a substantial “super-elastic plateau” or “flag region” in its stress/strain curve like super elastic nitinol does. Instead, in the linear elastic and/or non-super-elastic nitinol, as recoverable strain increases, the stress continues to increase in a substantially linear, or a somewhat, but not necessarily entirely linear relationship until plastic deformation begins or at least in a relationship that is more linear than the super elastic plateau and/or flag region that may be seen with super elastic nitinol. Thus, for the purposes of this disclosure linear elastic and/or non-super-elastic nitinol may also be termed “substantially” linear elastic and/or non-super-elastic nitinol.

**[0104]** In some cases, linear elastic and/or non-super-elastic nitinol may also be distinguishable from super elastic nitinol in that linear elastic and/or non-super-elastic nitinol may accept up to about 2-5% strain while remaining substantially elastic (e.g., before plastically deforming) whereas super elastic nitinol may accept up to about 8% strain before plastically deforming. Both of these materials can be distinguished from other linear elastic materials such as stain-

less steel (that can also be distinguished based on its composition), which may accept only about 0.2 to 0.44 percent strain before plastically deforming.

**[0105]** In some embodiments, the linear elastic and/or non-super-elastic nickel-titanium alloy is an alloy that does not show any martensite/austenite phase changes that are detectable by differential scanning calorimetry (DSC), dynamic mechanical thermal analysis (DMTA) analysis over a large temperature range and bend and free recovery (ASTM F2082). For example, in some embodiments, there may be no martensite/austenite phase changes detectable by DSC and DMTA analysis in the range of about -60 degrees Celsius (° C.) to about 120° C. in the linear elastic and/or non-super-elastic nickel-titanium alloy. The mechanical bending properties of such material may therefore be generally inert to the effect of temperature over this very broad range of temperature. In some embodiments, the mechanical bending properties of the linear elastic and/or non-super-elastic nickel-titanium alloy at ambient or room temperature are substantially the same as the mechanical properties at body temperature, for example, in that they do not display a super-elastic plateau and/or flag region. In other words, across a broad temperature range, the linear elastic and/or non-super-elastic nickel-titanium alloy maintains its linear elastic and/or non-super-elastic characteristics and/or properties.

**[0106]** In some embodiments, the linear elastic and/or non-super-elastic nickel-titanium alloy may be in the range of about 50 to about 60 weight percent nickel, with the remainder being essentially titanium. In some embodiments, the composition is in the range of about 54 to about 57 weight percent nickel. One example of a suitable nickel-titanium alloy is FHP-NT alloy commercially available from Furukawa Techno Material Co. of Kanagawa, Japan. Other suitable materials may include ULTANIUM™ (available from Neo-Metrics) and GUM METAL™ (available from Toyota). In some other embodiments, a superelastic alloy, for example a superelastic nitinol can be used to achieve desired properties.

**[0107]** In at least some embodiments, portions or all of the occlusive implant **10** and/or occlusive implant **110** (and variations, systems or components thereof disclosed herein) may also be doped with, made of, or otherwise include a radiopaque material. Radiopaque materials are understood to be materials capable of producing a relatively bright image on a fluoroscopy screen or another imaging technique during a medical procedure. This relatively bright image aids a user in determining the location of the occlusive implant **10** and/or occlusive implant **110** (and variations, systems or components thereof disclosed herein). Some examples of radiopaque materials can include, but are not limited to, gold, platinum, palladium, tantalum, tungsten alloy, polymer material loaded with a radiopaque filler, and the like. Additionally, other radiopaque marker bands and/or coils may also be incorporated into the design of the occlusive implant **10** and/or occlusive implant **110** (and variations, systems or components thereof disclosed herein) to achieve the same result.

**[0108]** In some embodiments, a degree of Magnetic Resonance Imaging (MM) compatibility is imparted into the occlusive implant **10** and/or occlusive implant **110** (and variations, systems or components thereof disclosed herein). For example, the occlusive implant **10** and/or occlusive implant **110** (and variations, systems or components thereof

disclosed herein) and/or components or portions thereof, may be made of a material that does not substantially distort the image and create substantial artifacts (e.g., gaps in the image). Certain ferromagnetic materials, for example, may not be suitable because they may create artifacts in an MRI image. The occlusive implant **10** (and variations, systems or components disclosed herein) or portions thereof, may also be made from a material that the MM machine can image. Some materials that exhibit these characteristics include, for example, tungsten, cobalt-chromium-molybdenum alloys (e.g., UNS: R44003 such as ELGILOY®, PHYNOX®, and the like), nickel-cobalt-chromium-molybdenum alloys (e.g., UNS: R44035 such as MP35-N® and the like), nitinol, and the like, and others.

**[0109]** In some embodiments, the occlusive implant **10** and/or occlusive implant **110** (and variations, systems or components thereof disclosed herein) and/or portions thereof, may be made from or include a polymer or other suitable material. Some examples of suitable polymers may include copolymers, polyisobutylene-polyurethane, polytetrafluoroethylene (PTFE), ethylene tetrafluoroethylene (ETFE), fluorinated ethylene propylene (FEP), polyoxymethylene (POM, for example, DELRIN® available from DuPont), polyether block ester, polyurethane (for example, Polyurethane 85A), polypropylene (PP), polyvinylchloride (PVC), polyether-ester (for example, ARNITEL® available from DSM Engineering Plastics), ether or ester based copolymers (for example, butylene/poly(alkylene ether) phthalate and/or other polyester elastomers such as HYTREL® available from DuPont), polyamide (for example, DURETHAN® available from Bayer or CRISTAMID® available from Elf Atochem), elastomeric polyamides, block polyamide/ethers, polyether block amide (PEBA, for example available under the trade name PEBAX®), ethylene vinyl acetate copolymers (EVA), silicones, polyethylene (PE), Marlex high-density polyethylene, Marlex low-density polyethylene, linear low density polyethylene (for example REXELL®), polyester, polybutylene terephthalate (PBT), polyethylene terephthalate (PET), polytrimethylene terephthalate, polyethylene naphthalate (PEN), polyetheretherketone (PEEK), polyimide (PI), polyetherimide (PEI), polyphenylene sulfide (PPS), polyphenylene oxide (PPO), poly paraphenylene terephthalamide (for example, KEVLAR®), polysulfone, nylon, nylon-12 (such as GRILAMID® available from EMS American Grilon), perfluoro (propyl vinyl ether) (PFA), ethylene vinyl alcohol, polyolefin, polystyrene, epoxy, polyvinylidene chloride (PVdC), poly(styrene-b-isobutylene-b-styrene) (for example, SIBS and/or SIBS 50A), polycarbonates, ionomers, polyurethane silicone copolymers (for example, ElastEon® from Aortech Biomaterials or ChronoSil® from AdvanSource Biomaterials), biocompatible polymers, other suitable materials, or mixtures, combinations, copolymers thereof, polymer/metal composites, and the like. In some embodiments, the sheath can be blended with a liquid crystal polymer (LCP). For example, the mixture can contain up to about 6 percent LCP.

**[0110]** In some embodiments, the occlusive implant **10** and/or occlusive implant **110** (and variations, systems or components thereof disclosed herein) may include a textile material. Some examples of suitable textile materials may include synthetic yarns that may be flat, shaped, twisted, textured, pre-shrunk or un-shrunk. Synthetic biocompatible yarns suitable for use in the present disclosure include, but

are not limited to, polyesters, including polyethylene terephthalate (PET) polyesters, polypropylenes, polyethylenes, polyurethanes, polyolefins, polyvinyls, polymethylacrylates, polyamides, naphthalene dicarboxylene derivatives, natural silk, and polytetrafluoroethylenes. Moreover, at least one of the synthetic yarns may be a metallic yarn or a glass or ceramic yarn or fiber. Useful metallic yarns include those yarns made from or containing stainless steel, platinum, gold, titanium, tantalum or a Ni—Co—Cr-based alloy. The yarns may further include carbon, glass or ceramic fibers. Desirably, the yarns are made from thermoplastic materials including, but not limited to, polyesters, polypropylenes, polyethylenes, polyurethanes, polynaphthalenes, polytetrafluoroethylenes, and the like. The yarns may be of the multifilament, monofilament, or spun-types. The type and denier of the yarn chosen may be selected in a manner which forms a biocompatible and implantable prosthesis and, more particularly, a vascular structure having desirable properties.

**[0111]** In some embodiments, the occlusive implant **10** and/or occlusive implant **110** (and variations, systems or components thereof disclosed herein) may include and/or be treated with a suitable therapeutic agent. Some examples of suitable therapeutic agents may include anti-thrombogenic agents (such as heparin, heparin derivatives, urokinase, and PPACK (dextrophenylalanine proline arginine chloromethylketone)); anti-proliferative agents (such as enoxaparin, angiostatin, monoclonal antibodies capable of blocking smooth muscle cell proliferation, hirudin, and acetylsalicylic acid); anti-inflammatory agents (such as dexamethasone, prednisolone, corticosterone, budesonide, estrogen, sulfasalazine, and mesalamine); antineoplastic/antiproliferative/anti-mitotic agents (such as paclitaxel, 5-fluorouracil, cisplatin, vinblastine, vincristine, epothilones, endostatin, angiostatin and thymidine kinase inhibitors); anesthetic agents (such as lidocaine, bupivacaine, and ropivacaine); anti-coagulants (such as D-Phe-Pro-Arg chloromethyl ketone, an RGD peptide-containing compound, heparin, anti-thrombin compounds, platelet receptor antagonists, anti-thrombin antibodies, anti-platelet receptor antibodies, aspirin, prostaglandin inhibitors, platelet inhibitors, and tick antiplatelet peptides); vascular cell growth promoters (such as growth factor inhibitors, growth factor receptor antagonists, transcriptional activators, and translational promoters); vascular cell growth inhibitors (such as growth factor inhibitors, growth factor receptor antagonists, transcriptional repressors, translational repressors, replication inhibitors, inhibitory antibodies, antibodies directed against growth factors, bifunctional molecules consisting of a growth factor and a cytotoxin, bifunctional molecules consisting of an antibody and a cytotoxin); cholesterol-lowering agents; vasodilating agents; and agents which interfere with endogenous vasoactive mechanisms.

**[0112]** While the discussion above is generally directed toward an occlusive implant for use in the left atrial appendage of the heart, the aforementioned features may also be useful in other types of medical implants where a fabric or membrane is attached to a frame or support structure including, but not limited to, implants for the treatment of aneurysms (e.g., abdominal aortic aneurysms, thoracic aortic aneurysms, etc.), replacement valve implants (e.g., replacement heart valve implants, replacement aortic valve implants, replacement mitral valve implants, replacement vascular valve implants, etc.), and/or other types of occlusive devices (e.g., atrial septal occluders, cerebral aneurysm

occluders, peripheral artery occluders, etc.). Other useful applications of the disclosed features are also contemplated. [0113] It should be understood that this disclosure is, in many respects, only illustrative. Changes may be made in details, particularly in matters of shape, size, and arrangement of steps without exceeding the scope of the disclosure. This may include, to the extent that it is appropriate, the use of any of the features of one example embodiment being used in other embodiments. The disclosure's scope is, of course, defined in the language in which the appended claims are expressed.

What is claimed is:

1. A system for detecting leakage around an occlusive implant disposed in the left atrial appendage, the system comprising:

an elongate shaft having a port disposed at a distal end region thereof; and

a first sensor disposed adjacent the elongate shaft;

wherein the elongate shaft is configured to be positioned adjacent the occlusive implant such that the first sensor is positioned on a first side of the occlusive implant, and wherein the port is positioned on a second side of the occlusive implant;

wherein the first sensor is configured to measure a first parameter;

wherein the first parameter is utilized to determine a fluid leak between the occlusive implant and a tissue wall defining the left atrial appendage.

2. The system of claim 1, wherein the first parameter includes at least one of a fluid flowrate, a fluid pressure and a fluid temperature.

3. The system of claim 1, wherein the elongate shaft is configured to inject fluid into the left atrial appendage.

4. The system of claim 1, wherein the elongate shaft is configured to vacuum fluid out of the left atrial appendage.

5. The system of claim 1, further comprising a core wire coupled to the occlusive implant, and wherein the first sensor is disposed on the core wire.

6. The system of claim 5, further comprising a second sensor disposed on a hub of the occlusive implant.

7. The system of claim 1, wherein the first sensor is attached to the elongate shaft.

8. The system of claim 7, further comprising a second sensor attached to the elongate shaft on the second side of the implant.

9. The system of claim 1, wherein the elongate shaft includes a core wire and a second sensor, wherein the core wire is coupled to the occlusive implant, and wherein the first sensor is disposed on the core wire on the first side of the implant, and wherein the second sensor is disposed on the core wire on the second side of the implant.

10. The system of claim 9, further comprising a membrane coupled to the first side of the occlusive implant.

11. The system of claim 10, wherein the membrane is configured to prevent fluid from passing therethrough.

12. The system of claim 11, wherein the membrane is retractable.

13. The system of claim 12, wherein the membrane includes an absorbable material.

14. The system of claim 1, wherein the sensor is wireless.

15. A system for detecting leakage around an occlusive implant disposed in the left atrial appendage, the system comprising:

an elongate shaft having a first sensor disposed on a first portion thereof and a second sensor disposed along a second portion thereof;

wherein the elongate shaft is configured to be positioned adjacent the occlusive implant such that the first sensor is positioned on a first side of the occlusive implant, and wherein the second sensor is positioned on a second side of the occlusive implant;

wherein the first sensor is configured to measure a first parameter;

wherein the second sensor is configured to measure a second parameter;

wherein the first parameter is compared to the second parameter to determine a fluid leak between the occlusive implant and a tissue wall defining the left atrial appendage.

16. The system of claim 15, wherein the first parameter, the second parameter or both the first parameter and the second parameter include at least one of a fluid flowrate, a fluid pressure and a fluid temperature.

17. The system of claim 15, wherein the elongate shaft is coupled to a hub on the occlusive implant.

18. The system of claim 15, further comprising a core wire coupled to the occlusive implant.

19. The system of claim 15, wherein the first sensor, the second sensor or both the first and second sensor are wireless.

20. A method for detecting leakage around an occlusive implant disposed in the left atrial appendage, the method comprising:

advancing an elongate shaft into the left atrial appendage, the elongate shaft including a first sensor disposed thereon and a port disposed at a distal end region thereof;

positioning the elongate shaft adjacent the occlusive implant such that the first sensor is positioned on a first side of the occlusive implant and the port is positioned on a second side of the occlusive implant;

measuring a first parameter with the first sensor;

utilizing the first parameter to determine a fluid leak between the occlusive implant and a tissue wall defining the left atrial appendage.

\* \* \* \* \*

专利名称(译)	闭塞密封传感器系统		
公开(公告)号	<a href="#">US20190336135A1</a>	公开(公告)日	2019-11-07
申请号	US16/400750	申请日	2019-05-01
[标]申请(专利权)人(译)	波士顿科学西美德公司		
申请(专利权)人(译)	BOSTON SCIENTIFIC SCIMED , INC.		
当前申请(专利权)人(译)	BOSTON SCIENTIFIC SCIMED , INC.		
[标]发明人	INOUYE JOSHUA MARK BERG BRIAN T ANDERSON JAMES M		
发明人	INOUYE, JOSHUA MARK PFLUGFELDER, ALEX BERG, BRIAN T. ONUSHKO, DAVID JOHN ANDERSON, JAMES M. LOHI, MARKUS PETTERI		
IPC分类号	A61B17/12 A61B5/00 A61B5/07 A61B5/0205		
CPC分类号	A61B2017/00004 A61B5/4851 A61B5/026 A61B2217/005 A61B5/6852 A61B5/07 A61B17/12031 A61B5/02055 A61B5/686 A61B2017/00632 A61B5/0215 A61B2217/007 A61B17/12122 A61B5/02007 A61B5/02042 A61B5/02158		
优先权	62/665830 2018-05-02 US		
外部链接	<a href="#">Espacenet</a> <a href="#">USPTO</a>		

摘要(译)

公开了一种用于检测植入物周围的泄漏的示例系统。用于检测设置在左心耳中的闭塞植入物周围的泄漏的示例系统包括：细长轴，其端口设置在其远端区域；以及第一传感器，其邻近细长轴设置。细长轴被配置为邻近闭塞植入物定位，使得第一传感器定位在闭塞植入物的第一侧上，而端口定位在闭塞植入物的第二侧上。此外，第一传感器被配置为测量第一参数，并且第一参数被用于确定闭塞性植入物与限定左心耳的组织壁之间的流体泄漏。

