



(19) **United States**

(12) **Patent Application Publication**
Pushpala et al.

(10) **Pub. No.: US 2018/0140235 A1**

(43) **Pub. Date: May 24, 2018**

(54) **SYSTEM FOR MONITORING BODY CHEMISTRY**

A61B 5/01 (2006.01)

A61B 17/34 (2006.01)

A61B 5/1486 (2006.01)

(71) Applicant: **Sano Intelligence, Inc.**, San Francisco, CA (US)

(52) **U.S. Cl.**

CPC *A61B 5/14514* (2013.01); *A61B 5/685*

(2013.01); *A61B 5/01* (2013.01); *A61B*

5/14532 (2013.01); *A61B 17/3468* (2013.01);

A61B 5/7285 (2013.01); *A61B 2562/164*

(2013.01); *A61B 5/6849* (2013.01); *A61B*

5/6833 (2013.01); *A61B 5/14865* (2013.01);

A61B 2562/028 (2013.01); *A61B 2562/046*

(2013.01); *A61B 5/0002* (2013.01)

(72) Inventors: **Ashwin Pushpala**, San Francisco, CA (US); **Matthew Chapman**, San Francisco, CA (US); **Alan Szmodis**, San Francisco, CA (US); **Abhijit Ghosh**, San Francisco, CA (US)

(21) Appl. No.: **15/876,678**

(22) Filed: **Jan. 22, 2018**

(57)

ABSTRACT

Related U.S. Application Data

(63) Continuation of application No. 15/412,229, filed on Jan. 23, 2017, which is a continuation of application No. 15/377,318, filed on Dec. 13, 2016, which is a continuation of application No. 14/657,973, filed on Mar. 13, 2015, now abandoned.

(60) Provisional application No. 61/952,594, filed on Mar. 13, 2014, provisional application No. 62/012,874, filed on Jun. 16, 2014, provisional application No. 62/025,174, filed on Jul. 16, 2014.

A system and method for monitoring body chemistry of a user, the system comprising: a housing supporting: a microsensor comprising a first and second working electrode, a reference electrode, and a counter electrode, and configured to access interstitial fluid of the user, and an electronics subsystem comprising a signal conditioning module that receives a signal stream, from the microsensor, wherein the electronics subsystem is configured to detect an impedance signal derived from two of the first working electrode, the second working electrode, the reference electrode, and the counter electrode; and a processing subsystem comprising: a first module configured to generate an analysis indicative of an analyte parameter of the user and derived from the signal stream and the impedance signal, and a second module configured to transmit information derived from the analysis to the user, thereby facilitating monitoring of body chemistry of the user.

Publication Classification

(51) **Int. Cl.**

A61B 5/145 (2006.01)

A61B 5/00 (2006.01)

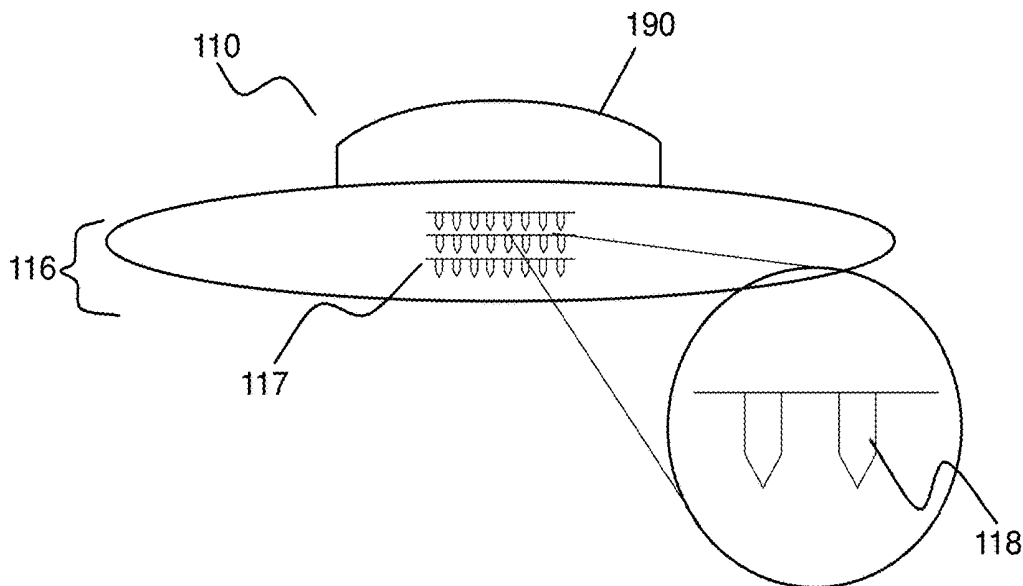

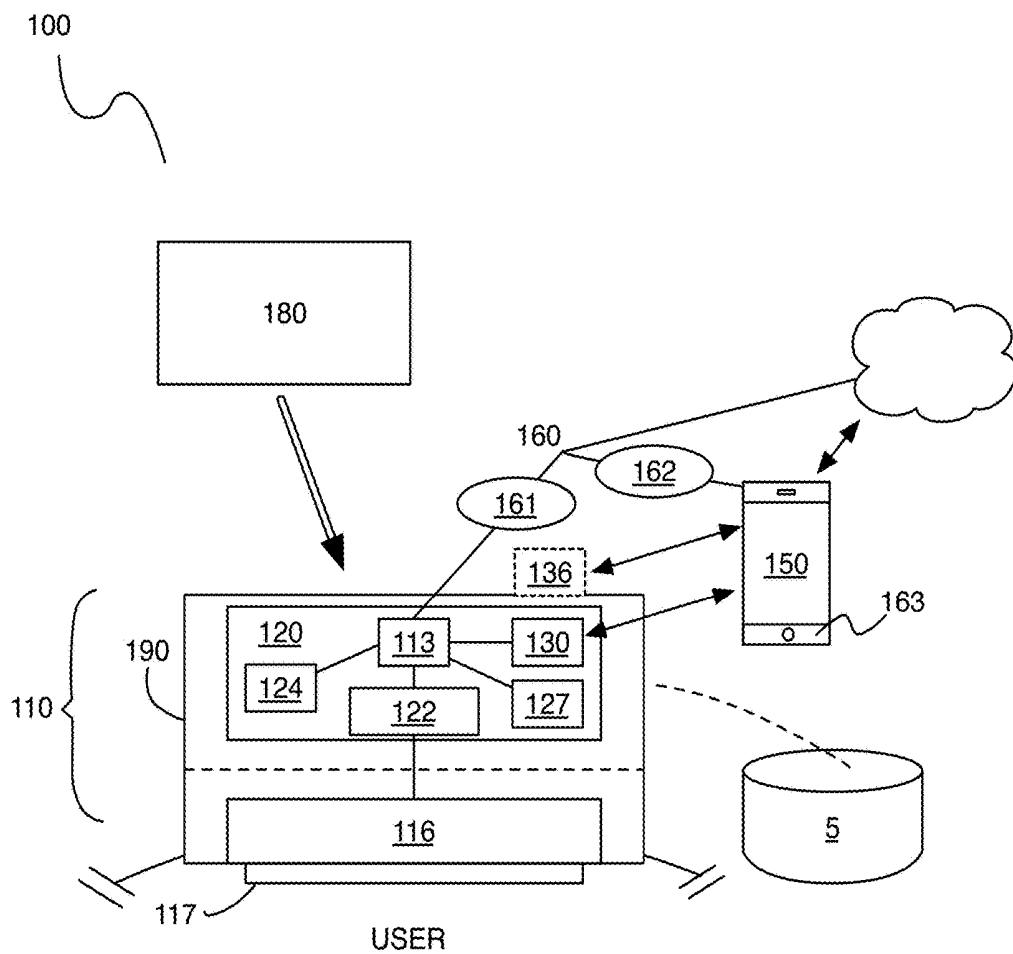

FIGURE 1

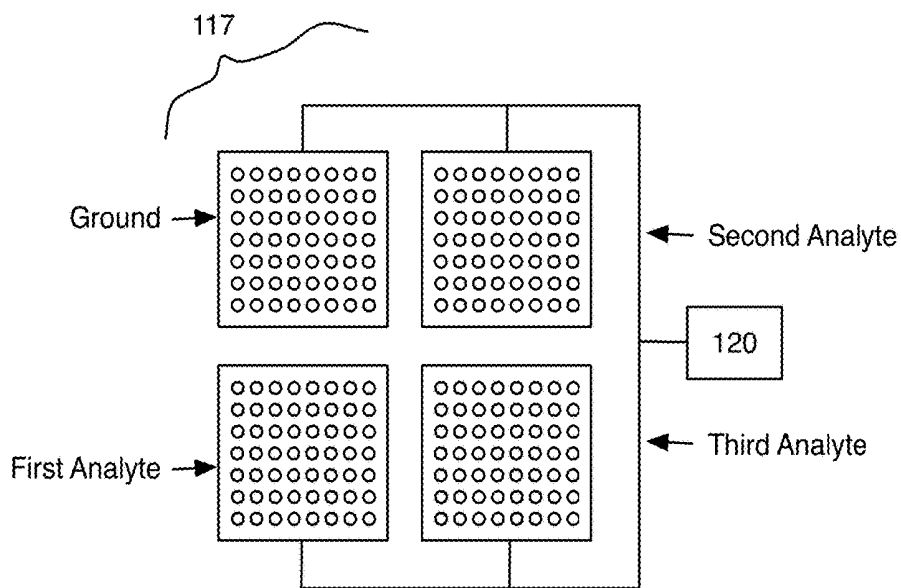
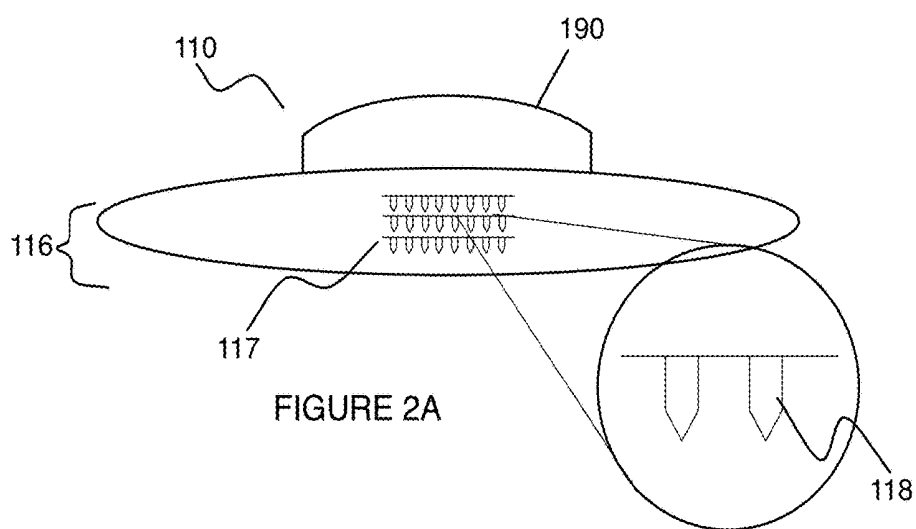

FIGURE 2B

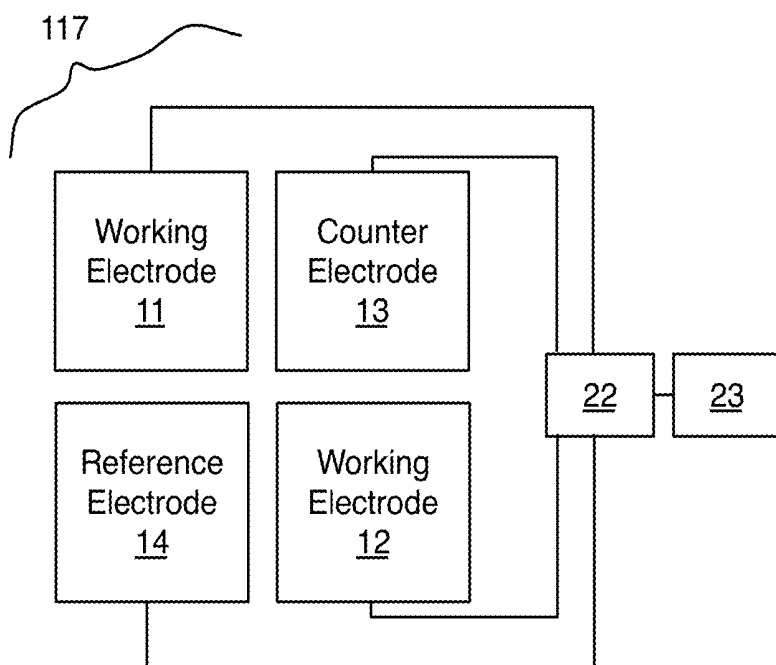

FIGURE 2C

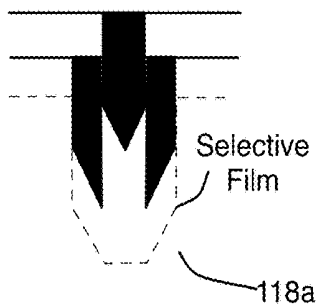

FIGURE 3A

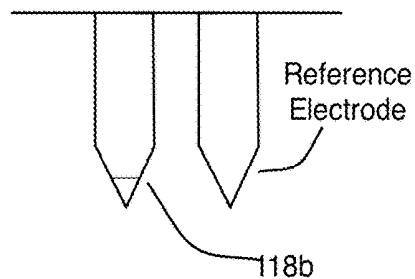

FIGURE 3B

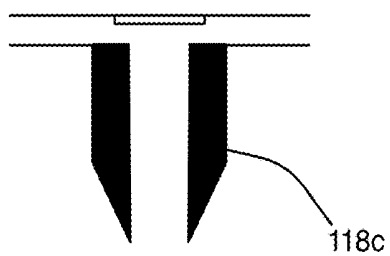

FIGURE 3C

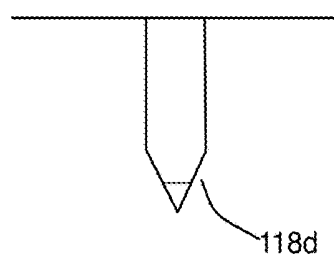

FIGURE 3D

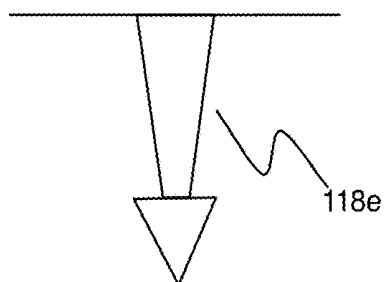

FIGURE 3E

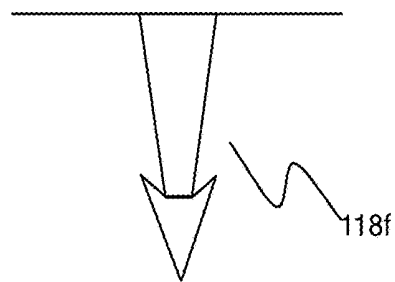

FIGURE 3F

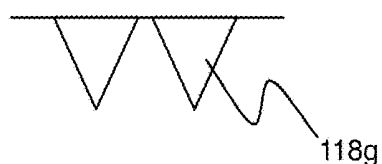

FIGURE 3G

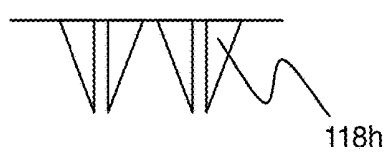

FIGURE 3H

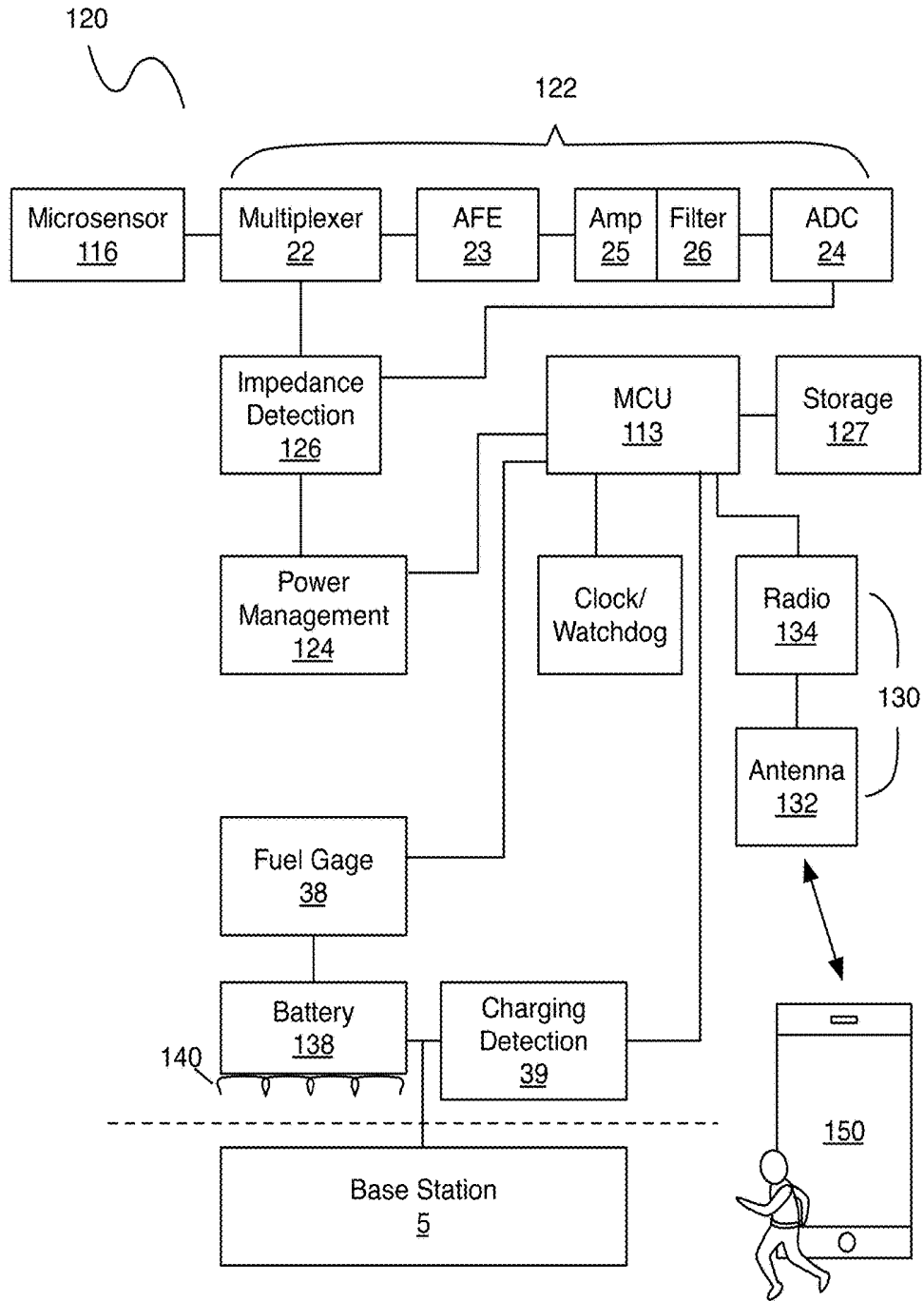

FIGURE 4

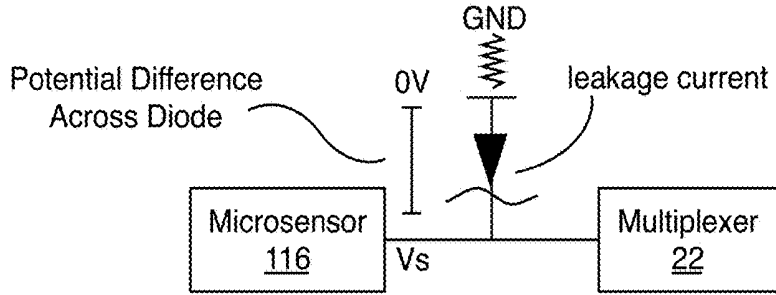

FIGURE 5A

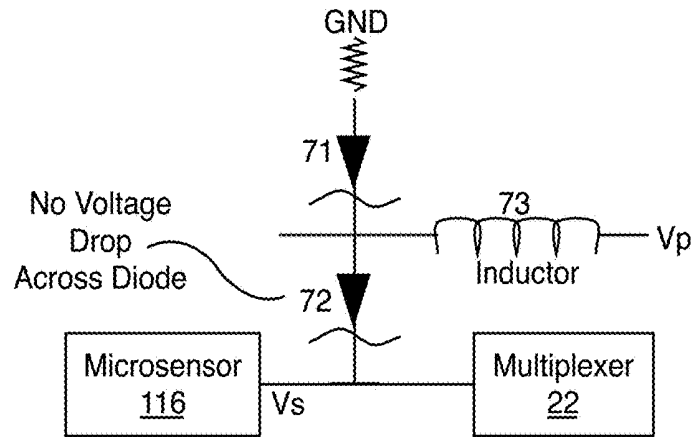

FIGURE 5B

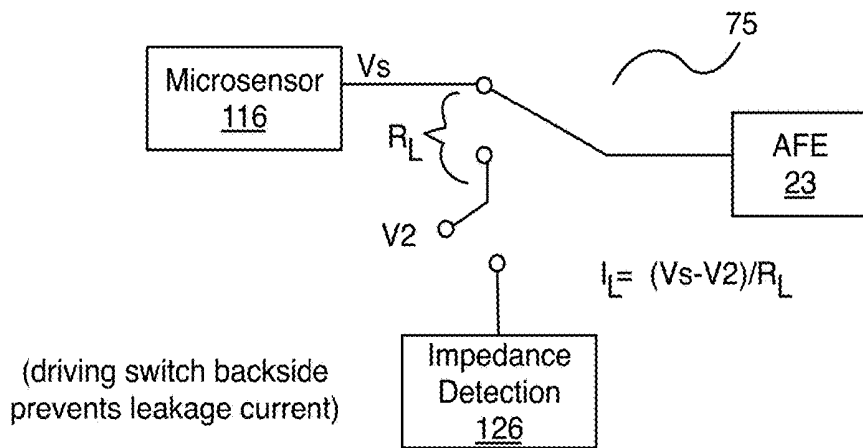

FIGURE 5C

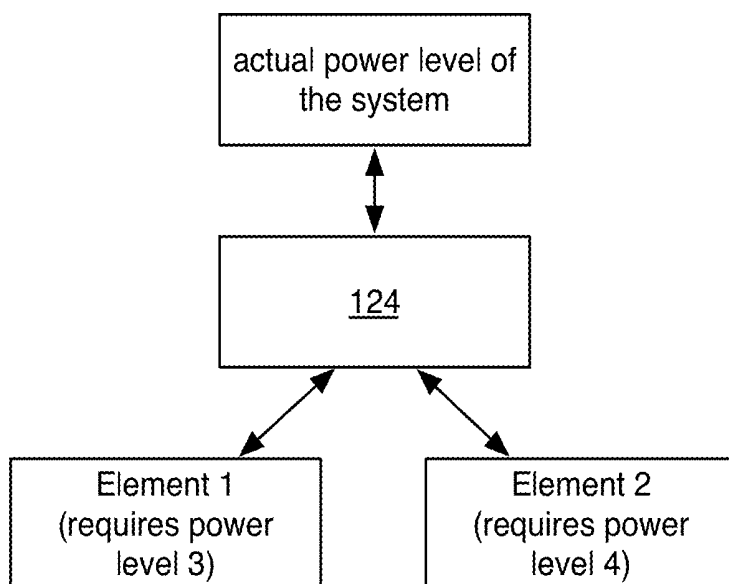

FIGURE 6A

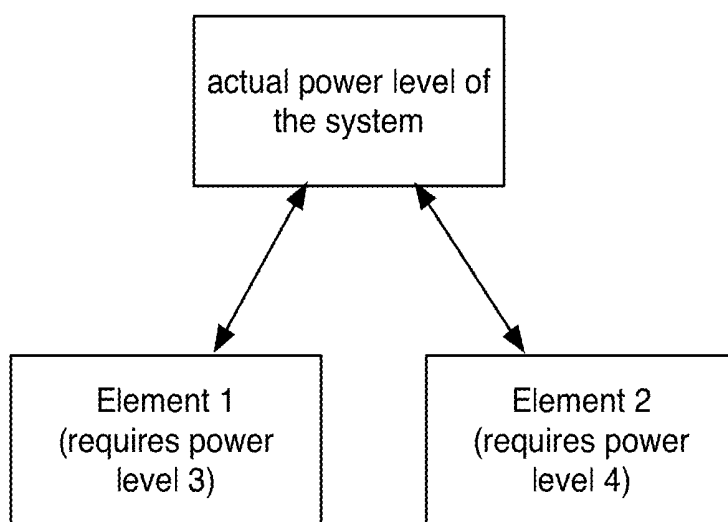

FIGURE 6B

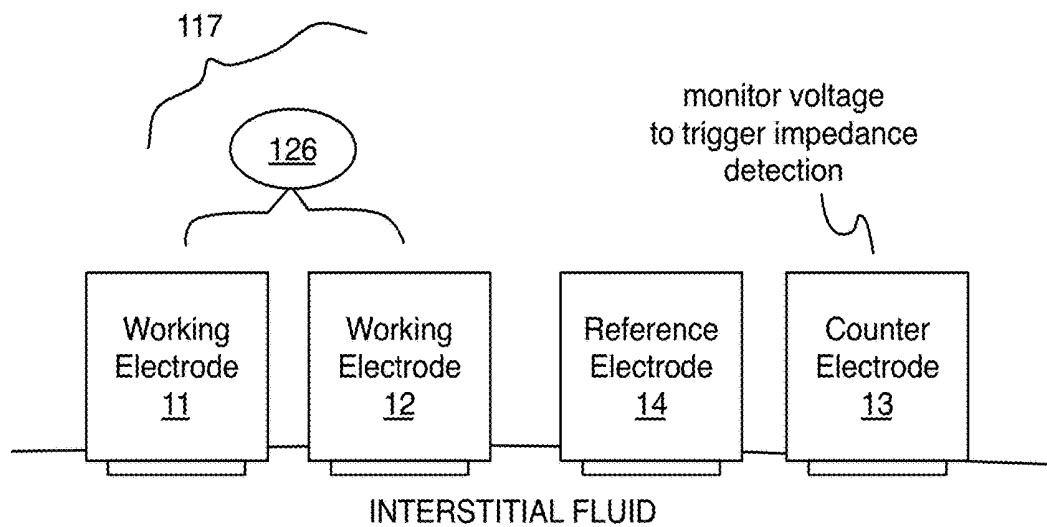

FIGURE 7

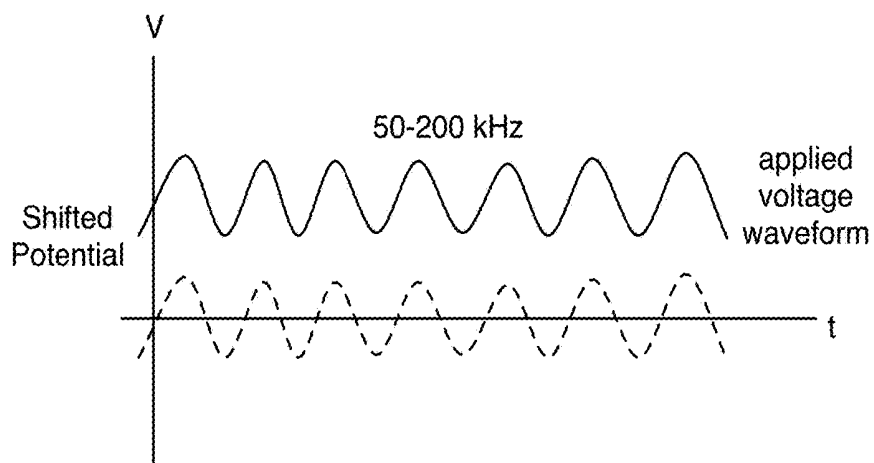

FIGURE 8

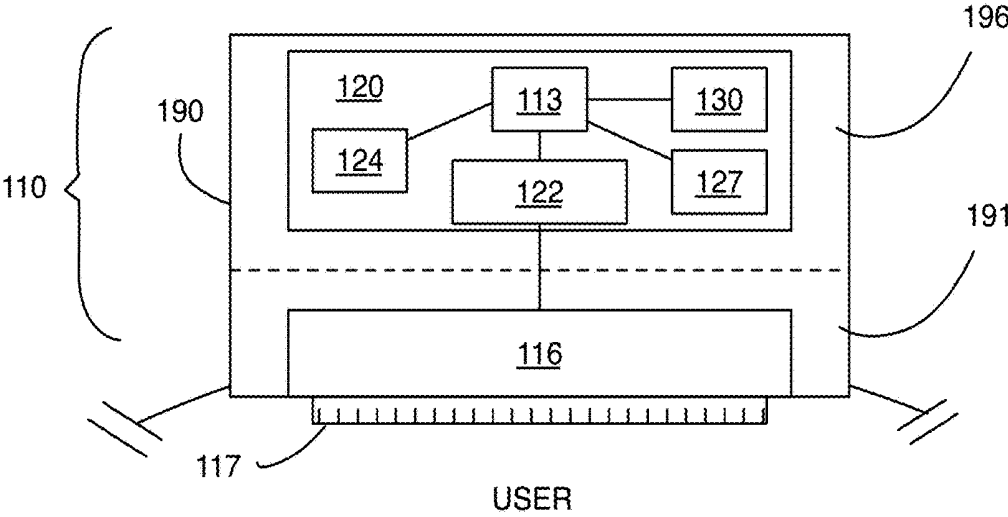

FIGURE 9

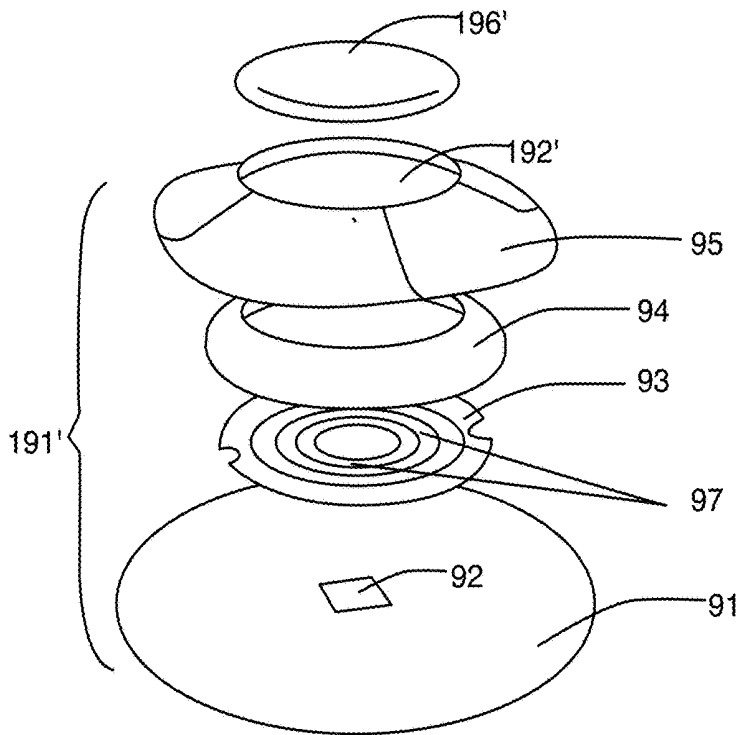

FIGURE 10A

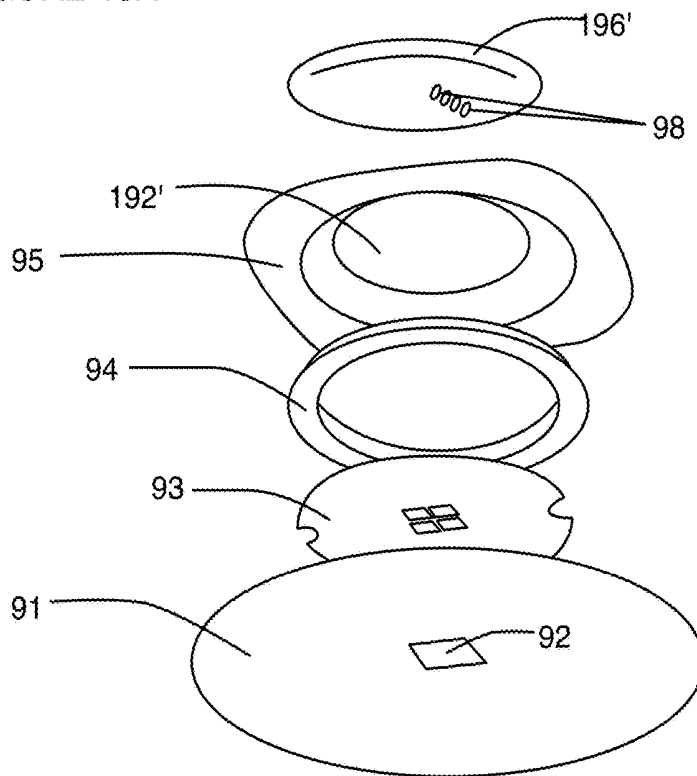

FIGURE 10B

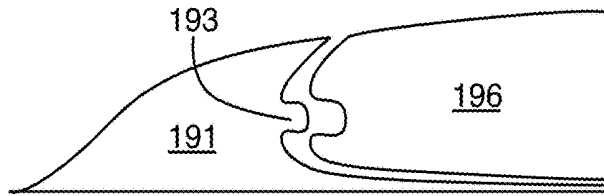

FIGURE 10C

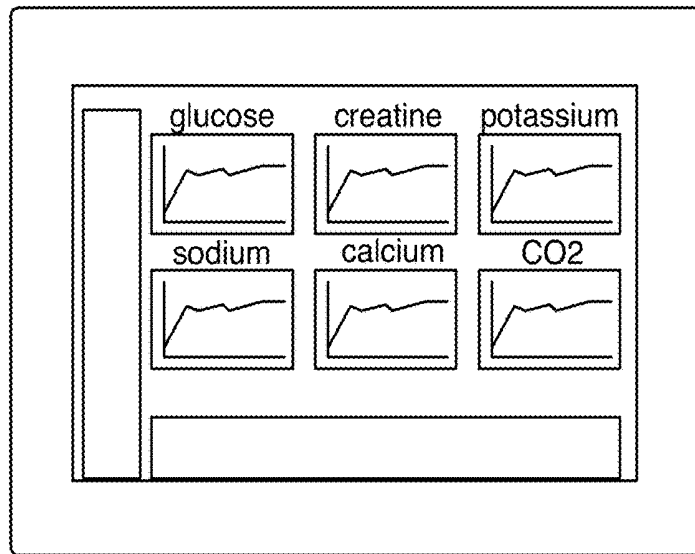

FIGURE 11A

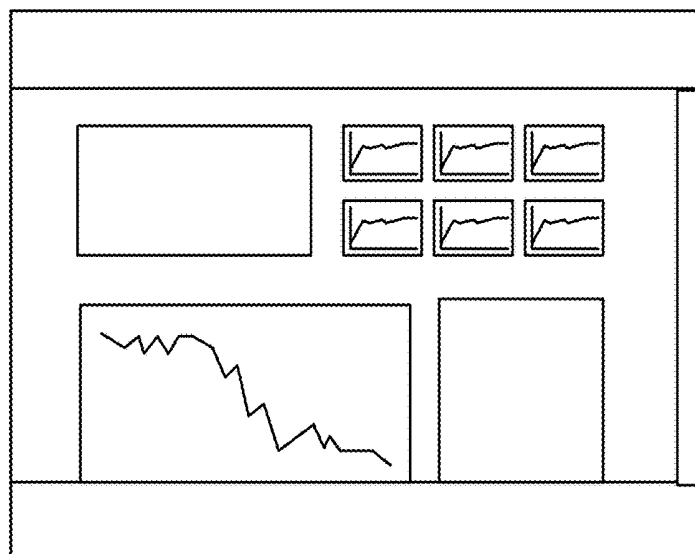

FIGURE 11B

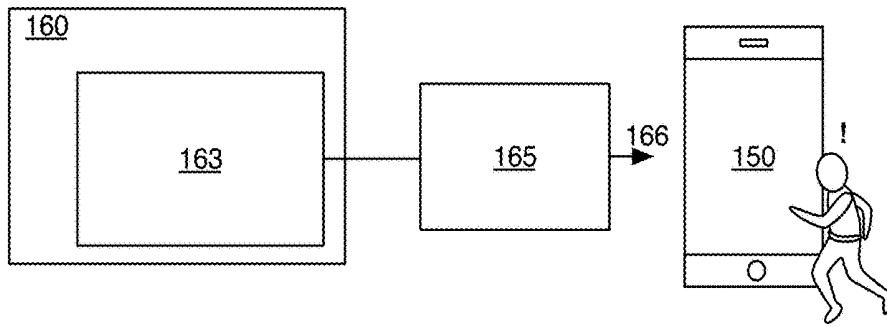

FIGURE 12A

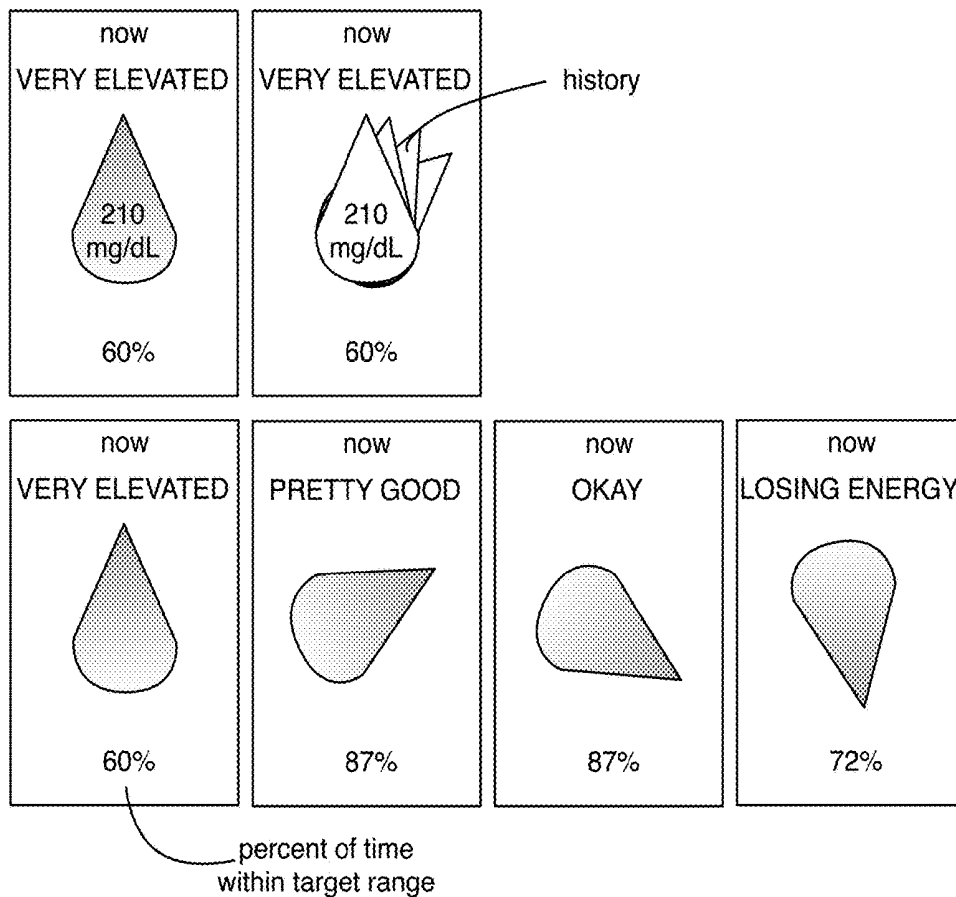

FIGURE 12B

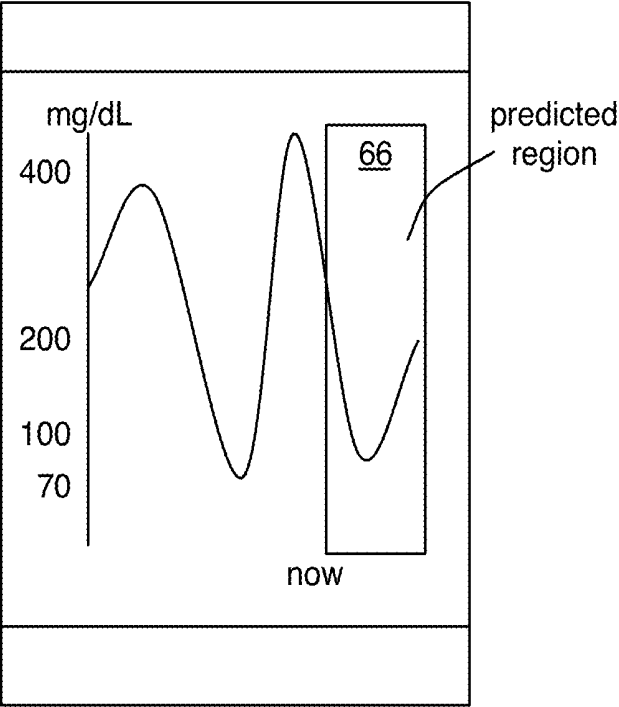

FIGURE 12C

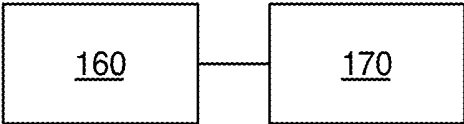

FIGURE 13

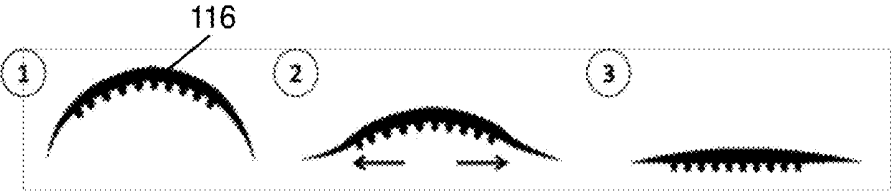

FIGURE 14A

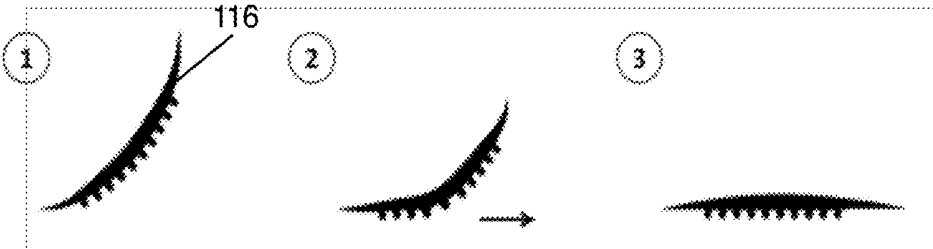

FIGURE 14B

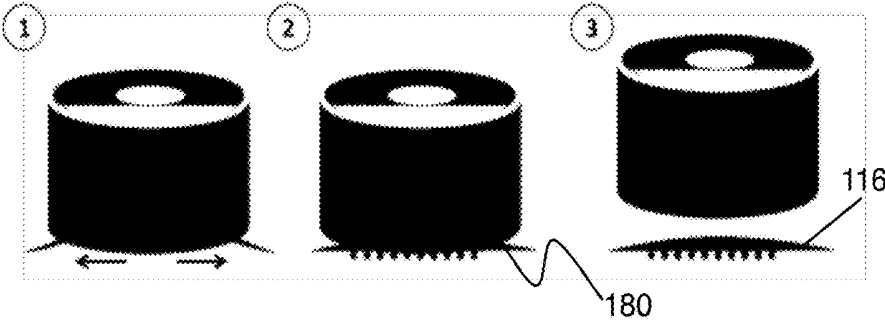

FIGURE 14C

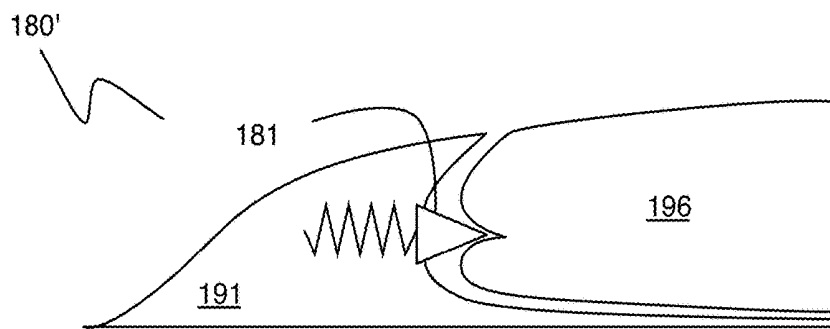

FIGURE 15A

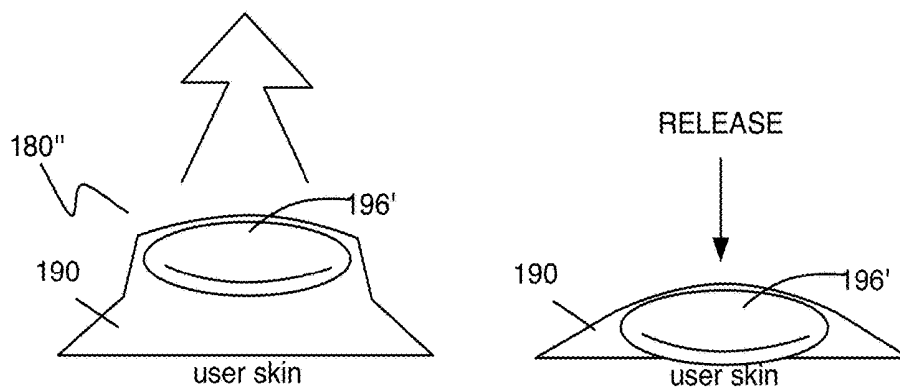

FIGURE 15B

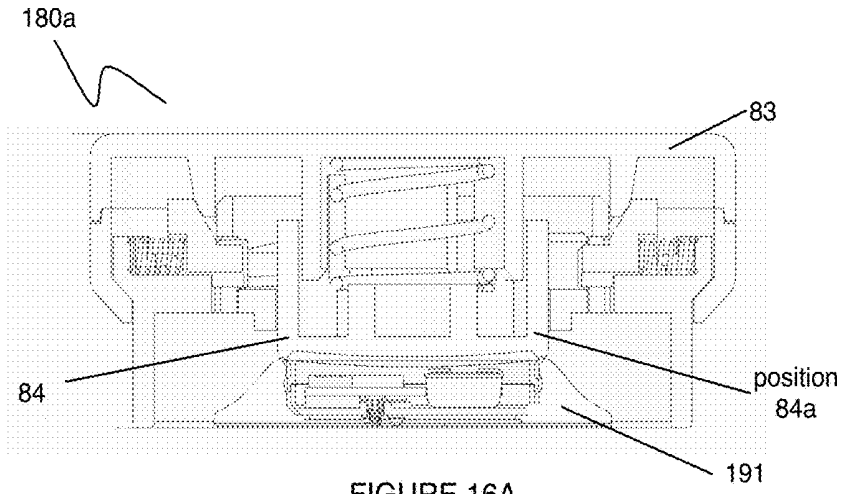

FIGURE 16A

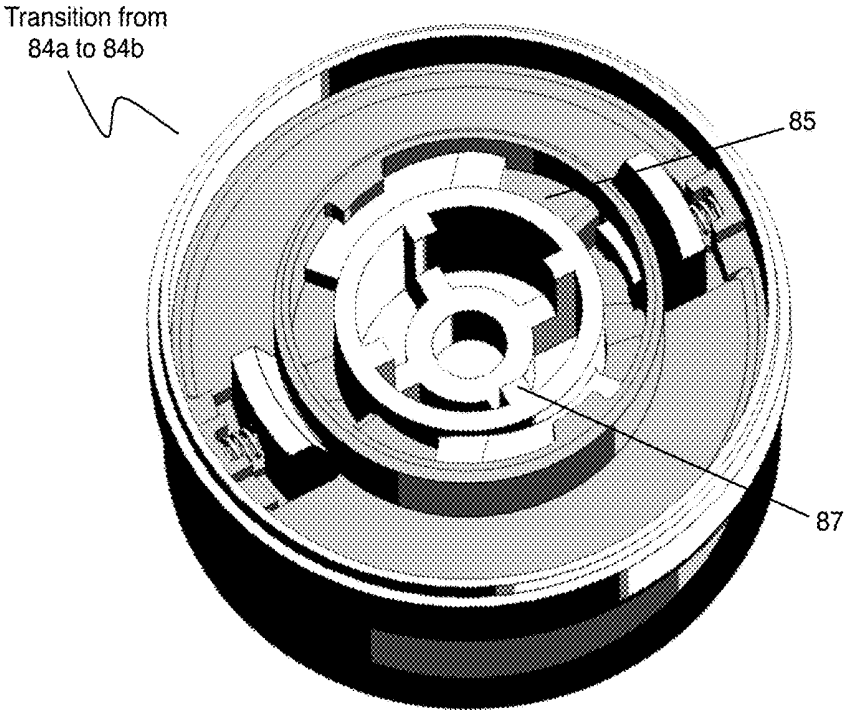

FIGURE 16B

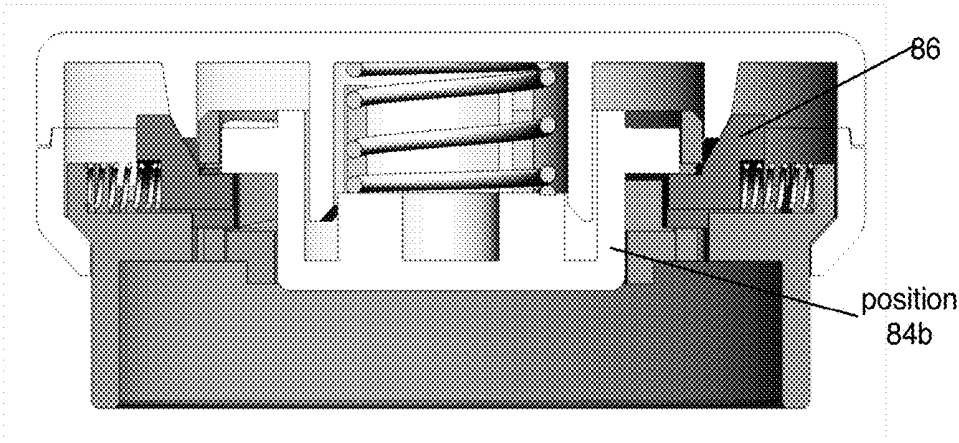

FIGURE 16C

downward force places outward biasing force on triggers, 86

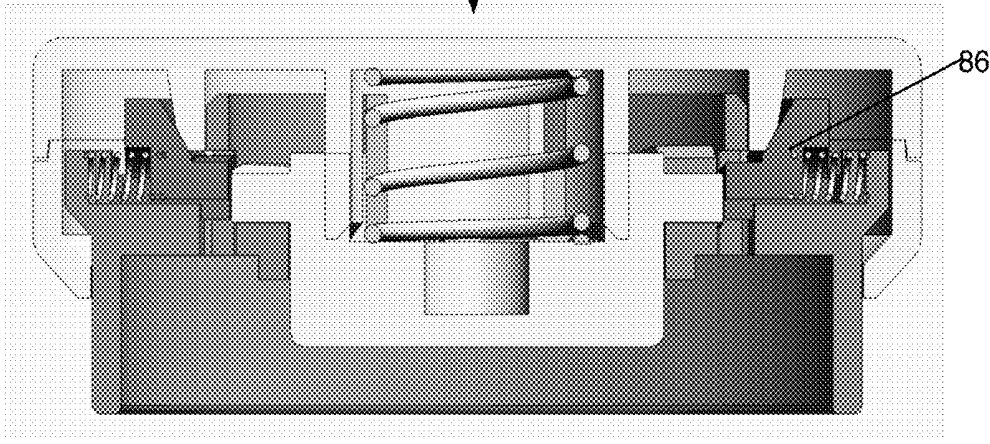
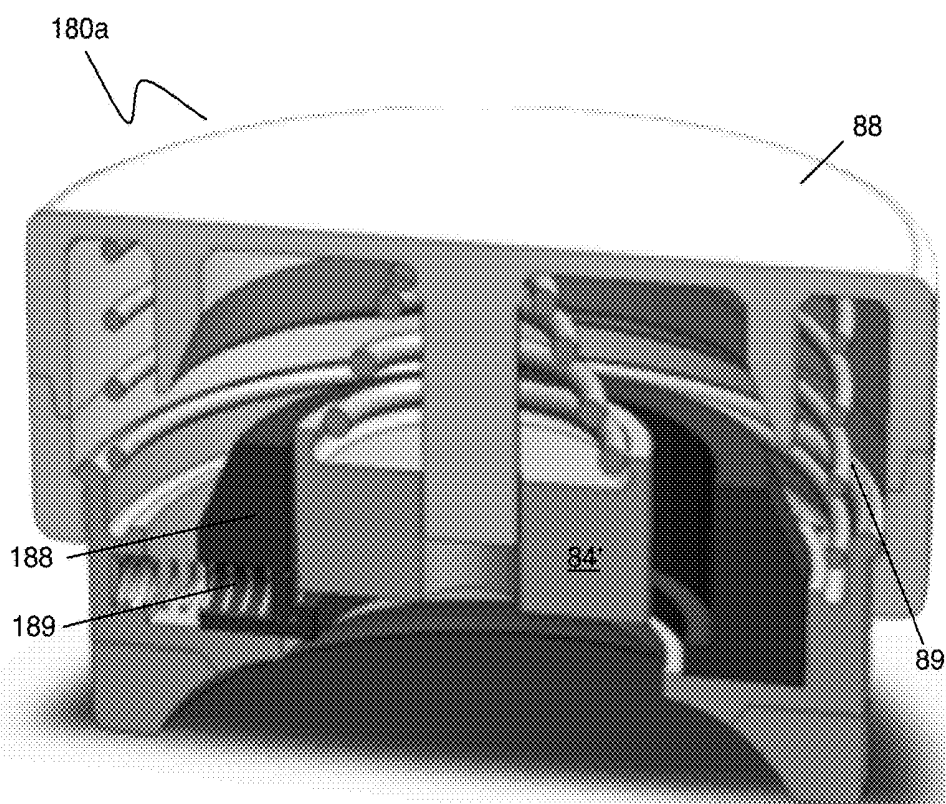

FIGURE 16D



Shown in configuration 188a. Downward force on 88 releases trigger (188) to accelerate plunger (84') downward in configuration 188b.

FIGURE 17

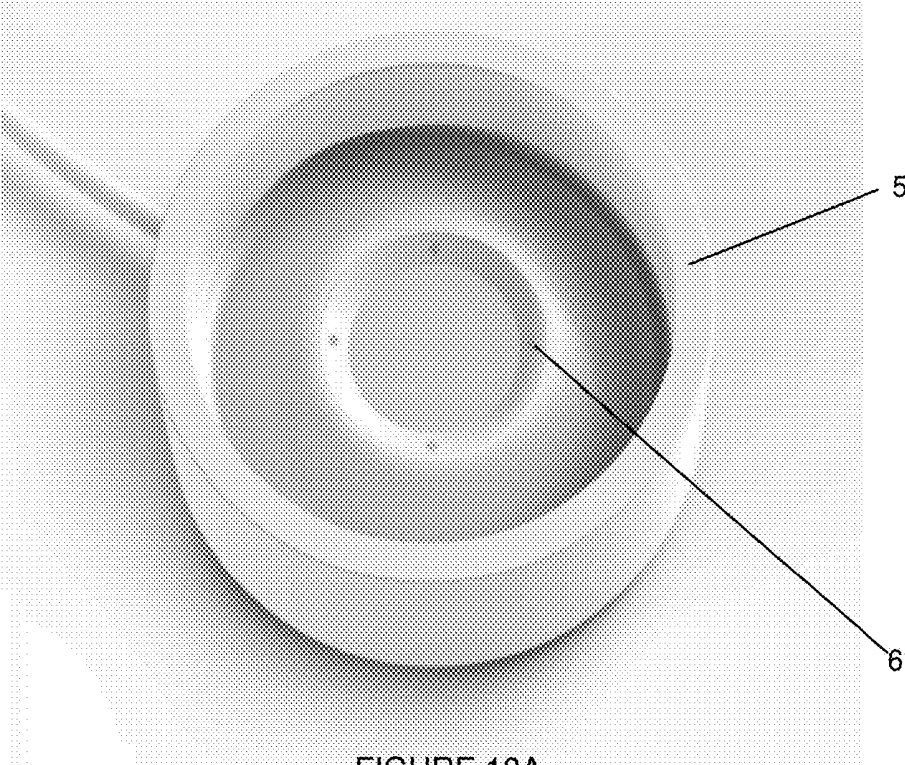

FIGURE 18A

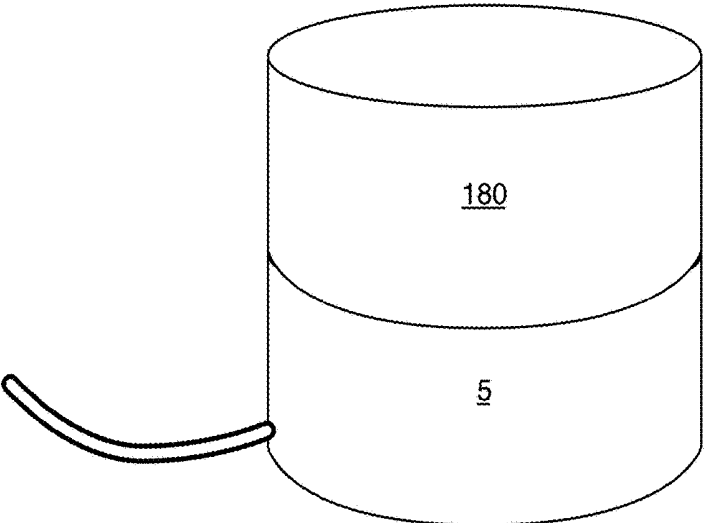

FIGURE 18B

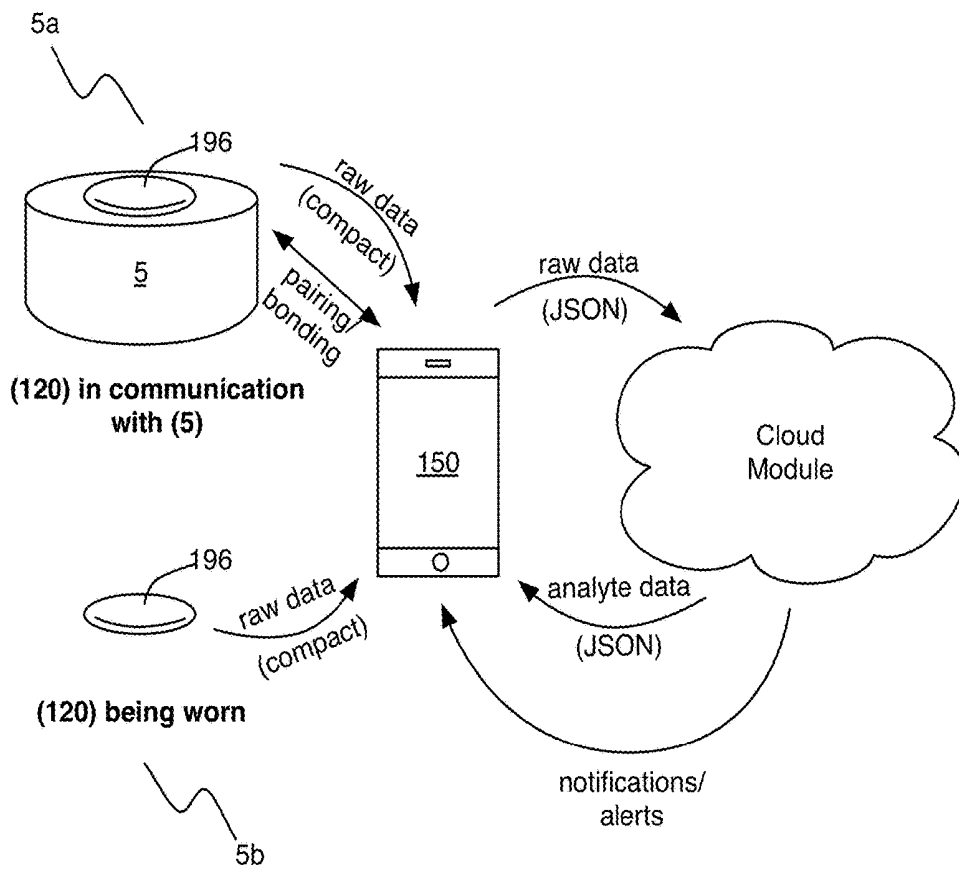

FIGURE 19

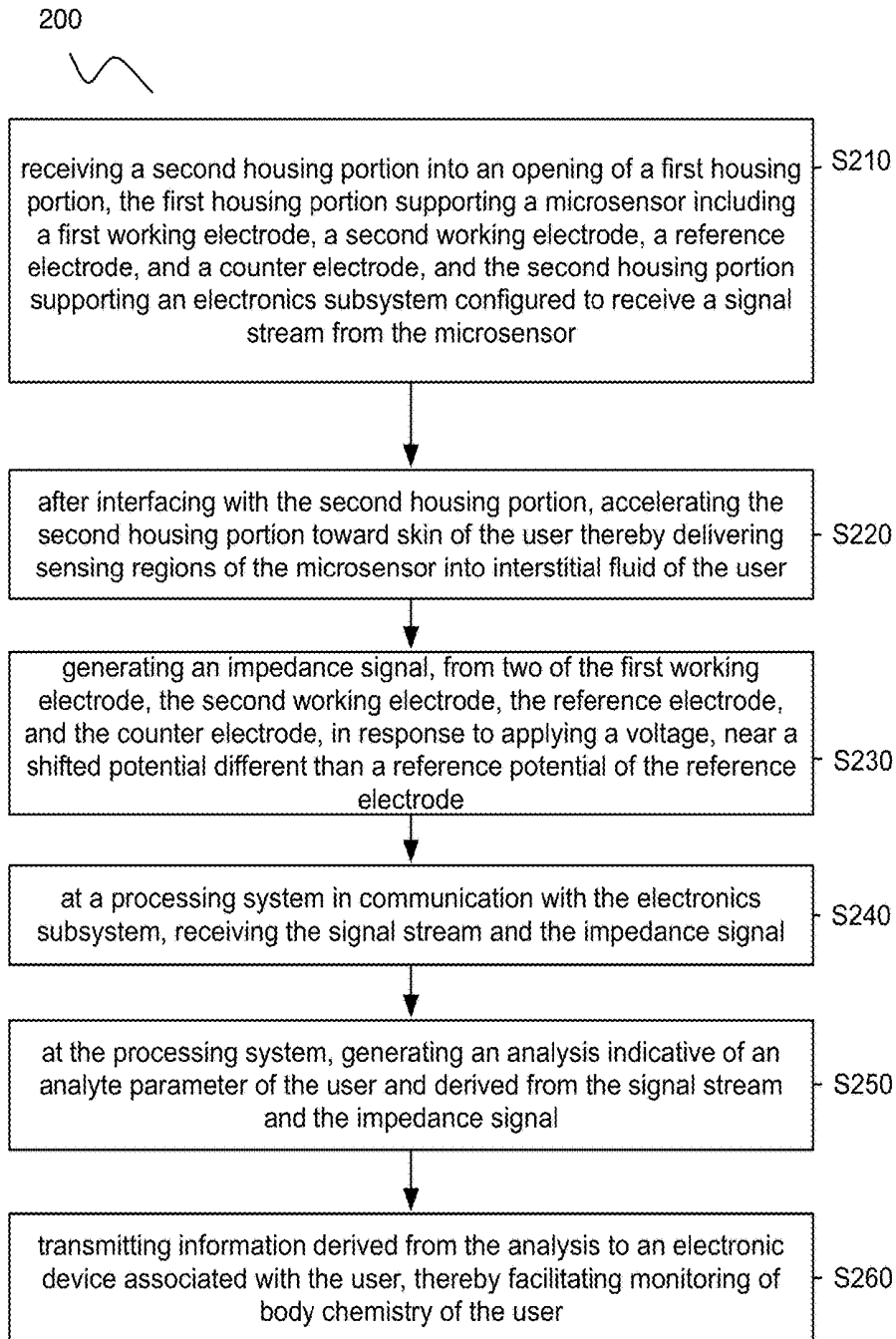

FIGURE 20

SYSTEM FOR MONITORING BODY CHEMISTRY

CROSS-REFERENCE TO RELATED APPLICATIONS

[0001] This application is a continuation of U.S. patent application Ser. No. 15/412,229, filed 23 Jan. 2017, which is a continuation of Ser. No. 15/377,318, filed 13 Dec. 2016, which is a continuation of U.S. patent application Ser. No. 14/657,973, filed 13 Mar. 2015, which claims the benefit of U.S. Provisional Application Ser. No. 61/952,594, filed on 13 Mar. 2014, U.S. Provisional Application Ser. No. 62/012,874, filed on 16 Jun. 2014, and U.S. Provisional Application Ser. No. 62/025,174, filed on 16 Jul. 2014, which are all incorporated herein in their entirety by this reference.

TECHNICAL FIELD

[0002] This invention relates generally to the biometric device field, and more specifically to a new and useful system for monitoring body chemistry in the biometric device field.

BACKGROUND

[0003] Biomonitoring devices are commonly used, particularly by health-conscious individuals and individuals diagnosed with ailments, to monitor body chemistry. Such biomonitoring devices perform the tasks of determining an analyte level in a user's body, and providing information regarding the analyte level to a user; however, these current biomonitoring devices typically convey information to users that is limited in detail, intermittent, and prompted by the command of the user. Such biomonitoring devices, including blood glucose meters, are also inappropriate for many applications outside of intermittent use, and place significant burdens on users (e.g., in requiring finger sticks, in requiring lancing, etc.) due to design and manufacture considerations. Additionally, current devices are configured to analyze one or a limited number of analytes contributing to overall body chemistry, due to limitations of sensors used in current biomonitoring devices.

[0004] There is thus a need in the biometric device field to create a new and useful system for monitoring body chemistry. This invention provides such a new and useful system.

BRIEF DESCRIPTION OF THE FIGURES

[0005] FIG. 1 depicts elements of an embodiment of a system for monitoring body chemistry;

[0006] FIGS. 2A and 2B depict embodiments of a microsensor patch, a transmitting unit, a housing, and an array of filaments in an embodiment of a system for monitoring body chemistry;

[0007] FIG. 2C depict a variation of electrodes in an embodiment of a system for monitoring body chemistry;

[0008] FIGS. 3A-3H depict examples of filament variations in an embodiment of a system for monitoring body chemistry;

[0009] FIG. 4 depicts an embodiment of an electronics subsystem in an embodiment of a system for monitoring body chemistry;

[0010] FIGS. 5A-5C depict examples of a portion of an electronics subsystem in an embodiment of a system for monitoring body chemistry;

[0011] FIGS. 6A-6B depict examples of power management modules in an embodiment of a system for monitoring body chemistry;

[0012] FIG. 7 depicts a variation of an impedance detection module in an embodiment of a system for monitoring body chemistry;

[0013] FIG. 8 depicts an example of an applied voltage waveform in an embodiment of a system for monitoring body chemistry;

[0014] FIG. 9 depicts a variation of a housing in an embodiment of a system for monitoring body chemistry;

[0015] FIGS. 10A-10B depict specific examples of a housing in an embodiment of a system for monitoring body chemistry;

[0016] FIG. 10C depicts a specific portion of a housing in an embodiment of a system for monitoring body chemistry;

[0017] FIGS. 11A-11B depict examples of user interfaces implemented using a software module in an embodiment of a system for monitoring body chemistry;

[0018] FIG. 12A depicts a notification module of an embodiment of a system for monitoring body chemistry;

[0019] FIGS. 12B-12C depict specific examples of notifications in an embodiment of a system for monitoring body chemistry;

[0020] FIG. 13 depicts communication between a processing subsystem and a storage module in an embodiment of a system for monitoring body chemistry;

[0021] FIGS. 14A-14C depict examples of an arch application method and an end-to-end application method, respectively, in an embodiment of a system for monitoring body chemistry;

[0022] FIGS. 15A-15B depict variations of a patch applicator in an embodiment of a system for monitoring body chemistry;

[0023] FIGS. 16A-16D depict a first specific example of a patch applicator in an embodiment of a system for monitoring body chemistry;

[0024] FIG. 17 depicts a second specific example of a patch applicator in an embodiment of a system for monitoring body chemistry;

[0025] FIGS. 18A-18B depict a specific example of a base station in an embodiment of a system for monitoring body chemistry;

[0026] FIG. 19 depicts operation modes of components of an embodiment of a system for monitoring body chemistry; and

[0027] FIG. 20 depicts an embodiment of a method for monitoring body chemistry.

DESCRIPTION OF THE PREFERRED EMBODIMENTS

[0028] The following description of the preferred embodiments of the invention is not intended to limit the invention to these preferred embodiments, but rather to enable any person skilled in the art to make and use this invention.

1. System

[0029] As shown in FIG. 1, an embodiment of the system 100 for monitoring body chemistry of a user comprises a housing 190 that supports a microsensor 116 and an electronics subsystem 120 in communication with the microsensor 116; and a processing subsystem 160 configured to generate an analysis indicative of an analyte parameter of

the user, wherein the analysis is derived from a signal stream of the microsensor and an impedance signal from the electronics subsystem. In more detail, the housing **190**, microsensor **116**, and the electronics subsystem **120** can be configured as a microsensor patch **110** configured to sense analyte levels in a user's body, wherein the electronics subsystem includes a signal conditioning module **122**, a power management module **124**, a storage module **127**, and a transmitting unit **130** in communication with the processing subsystem **160** and/or an electronic device (e.g., mobile computing device **150**) associated with the user.

[0030] In some variations, the system **100** can further include a patch applicator **180** configured to facilitate application of the microsensor patch **110** onto the body of a user in a reliable manner. The system **100** functions to provide continuous monitoring of a user's body chemistry through reception and processing of signals associated with one or more analytes present in the body of the user, and to provide an analysis of the user's body chemistry to the user and/or an entity (e.g., health care professional, caretaker, relative, friend, acquaintance, etc.) associated with the user. Alternatively, the system **100** can function to detect a user's body chemistry upon the user's request or sporadically, and/or can provide an analysis of the user's body chemistry only to the user.

[0031] The system **100** is configured to be worn by the patient outside of a clinical (e.g., hospital) or research (e.g., laboratory) setting, such that the patient can be in a non-contrived environment as he or she is interfacing with the microsensor patch **110** for monitoring of body chemistry. Furthermore, elements of the system **100** can be reusable or disposable (e.g., based upon modularity of the system **100**), or the entire system **100** can be configured to be disposable. In one specific example, the system **100** adheres to the patient (thus not compelling the patient to hold any part of the system **100** by hand), has a low profile that conforms to the patient, and is configured to receive and transmit signals indicative of body chemistry parameters of the user, for downstream analysis and information transfer to the user. Alternatively, the system **100** can be substantially non-portable, non-wearable, and/or intended for use in a clinical or research setting.

[0032] As indicated above and further below, elements of the system can be implemented on one or more computer networks, computer systems, or applications servers, etc. The computer system(s) can comprise one or more of: a cloud-based computer, a mainframe computer system, a grid-computer system, or any other suitable computer system, and the computer system can support collection of data from a wearable device and/or a base station, processing of these data, and transmission of alerts, notifications, and/or user interface updates to one or more electronic computing devices (e.g., mobile computing device, wrist-borne mobile computing device, head-mounted mobile computing device, etc.) linked to or affiliated with an account of the user. For example, the computer system can receive signals indicative of one or more analyte parameters of the user and distribute alerts and notifications over a distributed network, such as over a cellular network or over an Internet connection. In this example, the computer system can upload alerts and notifications to a native body chemistry monitoring application including the user interface and executing on a mobile computing device associated with the user.

[0033] Additionally or alternatively, an electronic computing device (e.g., a laptop computer, a desktop computer, a tablet, a smartphone, a smart watch, a smart eyewear accessory, a personal data assistant, etc.) associated with the system (e.g., with the account of the user) can maintain the account of the user, create and maintain a user-specific model within the account, and execute a native body chemistry monitoring application (including the user interface) with functions including one or more of: generating alerts or notifications, receiving alerts or notifications, displaying alerts or notifications, updating predictions of changes in state of the user, and any other suitable function that enhances body chemistry monitoring of the user. The system **100** is preferably configured to implement at least a portion of the method **200** described in Section 2 below; however, the system **100** can additionally or alternatively be configured to implement any other suitable method.

1.1 System—Microsensor Patch

[0034] As shown in FIG. 1, the microsensor patch **110** comprises a microsensor **116** and an electronics subsystem **120** in communication with the microsensor **116**, wherein the microsensor **116** and the electronics subsystem **120** are supported by a housing **190**. The microsensor patch **110** can be configured to detect and sense only a single analyte; however, the microsensor patch **110** can alternatively be configured to detect and sense multiple analytes in order to provide an analysis based on multiple analytes. Preferably, the microsensor patch **110** is configured to be disposable; however, the microsensor patch **110** can alternatively be configured to be reusable for any suitable duration or number of uses. In one variation, the microsensor patch **110** is configured to be a semi-permanent component (e.g., wearable for a week before replacement, wearable for a month before replacement, etc.) configured to sense the user's body chemistry with minimal signal degradation for at least a week post-coupling of the microsensor patch **110** to the body of the user. However, in another variation, the microsensor patch **110** can be configured to be a permanent component configured to permanently couple to a user. Modularity of the microsensor patch **110** is described in further detail below.

1.1.1 System—Microsensor

[0035] The microsensor **116** of the microsensor patch **110** preferably comprises an array of filaments **117**, as shown in FIGS. 1 and 2A, and functions to penetrate skin of the user in order to sense one or more analytes characterizing the user's body chemistry. Preferably, the array of filaments **117** is configured to penetrate the user's stratum corneum (i.e., an outer skin layer) in order to sense analytes within interstitial (extracellular) fluid, which is throughout the body; however, the array of filaments **117** can be configured to penetrate the user's skin to any other suitable depth. For instance, the microsensor **116** can alternatively be configured to penetrate deeper layers, or various depth layers of a user's skin in order to sense analytes within any appropriate bodily fluid of the user. The microsensor **116** can be configured to sense analytes/ions characterizing a user's body chemistry using a potentiometric measurement (e.g., for small analytes including potassium, sodium calcium, etc.), using an amperometric measurement (e.g., for large analytes

including glucose, lactic acid, creatinine, etc.), using a conductometric measurement, and/or using any other suitable measurement.

[0036] Preferably, sensed analytes result in a signal (e.g., voltage, current, resistance, capacitance, impedance, gravimetric, etc.) detectable by the electronics subsystem 120 in communication with the microsensor 116; however, analyte sensing can comprise any other appropriate mechanism using the microsensor 116. As mentioned earlier, the microsensor 116 is also preferably integrated with the electronics subsystem 120. In a first variation, the microsensor 116 is coupled to the semiconductor architecture of the electronics subsystem 120 (e.g., the microsensor 116 is coupled to an integrated circuit comprising the electronics subsystem 120), in a second variation, the microsensor 116 is more closely integrated into the semiconductor architecture of the electronics subsystem 120 (e.g., there is closer integration between the microsensor 116 and an integrated circuit including the electronics subsystem 120), and in a third variation, the microsensor 116 and the electronics subsystem 120 are constructed in a system-on-a-chip fashion (e.g., all components are integrated into a single chip). As such, in some variations, filaments the array of filaments 117 of the microsensor 116 can be directly or indirectly integrated with electronics components, such that preprocessing of a signal from the microsensor 116 can be performed using the electronics components (e.g., of the array of filaments 117, of the electronics subsystem 120) prior to or after transmitting signals to the electronics subsystem 120 (e.g., to an analog front end, to an analog to digital converter). The electronics components can be coupled to a filament substrate, or otherwise integrated with the filaments in any suitable fashion (e.g., wired, using a contact pad, etc.). Alternatively, the electronics components can be fully integrated into the electronics subsystem 120 and configured to communicate with the microsensor 116, or the electronics components can be split between the microsensor and the electronics subsystem 120. The microsensor 116 can, however, comprise any other suitable architecture or configuration.

[0037] The microsensor 116 preferably senses analyte parameters using the array of filaments 117, such that absolute values of specific analytes/ions can be detected and analyzed. The microsensor 116 can additionally be configured to sense analyte parameters using the array of filaments 117, such that changes in values of specific analyte/ion parameters or derivatives thereof (e.g., trends in values of a parameter, slopes of curves characterizing a trend in a parameter vs. another parameter, areas under curves characterizing a trend, a duration of time spent within a certain parameter range, etc.) can be detected and analyzed. In one variation, sensing by the microsensor 116 is achieved at a low frequency at discrete time points (e.g., every minute, or every hour), and in another variation, sensing by the microsensor 116 is achieved substantially continuously at a high frequency (e.g., every picosecond, every millisecond, every second). In one specific example for blood chemistry analysis, the array of filaments 117 of the microsensor 116 is configured to sense one or more of: electrolytes, glucose, bicarbonate, creatinine, body urea nitrogen (BUN), sodium, iodide, iodine and potassium of a user's blood chemistry. In another specific example, the array of filaments 117 of the microsensor 116 is configured to sense at least one of biomarkers, cell count, hormone levels, alcohol content,

gases (e.g. carbon dioxide, oxygen, etc.), drug concentrations/metabolism, pH and analytes within a user's body fluid.

[0038] As shown in FIG. 2A, the array of filaments 117 is preferably located at the base surface of the microsensor patch 110, and functions to interface directly with a user in a transdermal manner (e.g., in accessing interstitial fluid) in order to sense at least one analyte/ion characterizing the user's body chemistry. The array of filaments 117 is preferably arranged in a uniform pattern with a specified density optimized to effectively penetrate a user's skin and provide an appropriate signal, while minimizing pain to the user. Additionally, the array of filaments 117 can be arranged in a manner to optimize coupling to the user, such that the microsensor firmly couples to the user over the lifetime usage of the system. For example, the filaments 118 can comprise several pieces and/or be attached to a flexible base to allow the array of filaments 117 to conform to a user's body. In one variation, the array of filaments 117 is arranged in a rectangular pattern, and in another variation, the array of filaments 117 is arranged in a circular or ellipsoid pattern. However, in other variations, the array of filaments 117 can be arranged in any other suitable manner (e.g., a random arrangement). The array of filaments 117 can also be configured to facilitate coupling to a user, by comprising filaments of different lengths or geometries. Having filaments 118 of different lengths can further function to allow measurement of different ions/analytes at different depths of penetration (e.g., a filament with a first length can sense one analyte at a first depth, and a filament with a second length can sense another analyte at a second depth). The array of filaments 117 can also comprise filaments 118 of different geometries (e.g., height, diameter) to facilitate sensing of analytes/ions at lower or higher concentrations. In one specific example, the array of filaments 117 is arranged at a density of 100 filaments per square centimeter and each filament 118 in the array of filaments 117 has a length of 250-350 microns, which allows appropriate levels of detection, coupling to a user, and pain experienced by the user.

[0039] Each filament 118 in the array of filaments 117 preferably functions to sense a single analyte; however, each filament 118 in the array of filaments 117 can additionally be configured to sense more than one analyte. Furthermore, the array of filaments 117 can be further configured, such that a subarray of the array of filaments 117 functions as a single sensor configured to sense a particular analyte or biomarker, as shown in FIG. 2B. Furthermore, any configuration of subarrays of the array of filaments 117 can additionally or alternatively be configured as one or more of: a working electrode, a counter electrode (i.e., auxiliary electrode), and a reference electrode, for instance, in a two-electrode cell, a three-electrode cell, or a more-than-three-electrode cell. In one variation, as shown in FIG. 2C, the array of filaments 117 of the microsensor 116 is configured as a first working electrode 11 (corresponding to a first subarray of filaments), a second working electrode 12 (corresponding to a second subarray of filaments), a counter electrode 13 (corresponding to a third subarray of filaments), and a reference electrode 14 (corresponding to a fourth subarray of filaments). In a specific example of this variation, each subarray associated with the first working electrode 11, the second working electrode 12, the counter electrode 13, and the reference electrode 14, respectively, is substantially identical in morphology (e.g., area of the microsensor). Furthermore, in the

specific example, each subarray has a square footprint, and the subarrays are configured in a 2x2 arrangement to define a larger square footprint. However, the array of filaments 117 can be configured as one or more of: a working electrode, a counter electrode, and a reference electrode in any other suitable manner, and can furthermore have any other suitable morphology(ies) and/or configuration relative to each other.

[0040] Additionally or alternatively, any subarray of the array of filaments 117 can be configured to release biomaterials (e.g., therapeutic substances, drugs) for treating a medical condition of a user (e.g., as facilitated by biomaterial dissolution in interstitial fluid). Multiple subarrays of the array of filaments can then be configured to sense different analytes/biomarkers, or the same analyte/biomarker. Furthermore, a subarray or a single filament 118 of the array of filaments 117 can be configured as a ground region of the microsensor 116, such that signals generated by the microsensor 116 in response to analyte detection can be normalized by the signals generated by the subarray or single filament 118 serving as a ground region. Preferably, all subarrays of the array of filaments 117 are substantially equal in size and density; however, each subarray of the array of filaments 117 can alternatively be optimized to maximize signal generation and detection in response to a specific analyte. In an example, analytes that are known to have a lower concentration within a user's body fluid can correspond to a larger subarray of the array of filaments 117. In another example, analytes that are known to have a higher concentration within a user's body fluid can correspond to a smaller subarray of the array of filaments 117. In one extreme example, an entire array of filaments can be configured to sense a single analyte, such that the microsensor 116 and microsensor patch 110 is configured to sense and detect only one analyte. In another extreme example, each single filament in an array can be configured to detect a single analyte allowing for detection of multiple analytes within a single array (e.g., for a 100-filament array, 100 analytes can be tested).

[0041] In other variations, a subarray of the array of filaments 117 can also be used to detect other physiologically relevant parameters, such as electrophysiological signals (e.g., electrocardiogram, electroencephalogram), body temperature, respiration, and skin impedance change (e.g., to measure hydration state or inflammatory response). In these other variations, the subarray can be dedicated to measuring these physiologically relevant parameters, which could be combined with analyte/ion parameter measurements in order to provide meaningful information to a user. As an example, the simultaneous measurement of potassium levels and electrocardiogram measurements, enabled by subarrays of the array of filaments 117, can provide a more complete diagnosis of cardiovascular problems or events than either measurement by itself.

[0042] A filament 118 of the array of filaments can comprise one or more of: a substrate core, the substrate core including a base end coupled to the substrate, a columnar protrusion having a proximal portion coupled to the base end and a distal portion, and a tip region coupled to the distal portion of the columnar protrusion and that facilitates access to the body fluid of the user; a conductive layer, isolated to the tip region of the substrate core and isolated away from the base end and the columnar protrusion as an active region that enables transmission of electronic signals generated

upon detection of an analyte; an insulating layer ensheathing the columnar protrusion and base end of the substrate core and exposing a portion of the conductive layer, thereby defining a boundary of the active region; a sensing layer, in communication with the active region, characterized by reversible redox behavior for transduction of an ionic concentration of the analyte into an electronic signal; an intermediate selective layer superficial to the conductive layer and deeper than the sensing layer, relative to a most distal point of the tip region of the filament, that facilitates detection of the analyte; an intermediate protective layer, superficial to the intermediate selective layer, including a functional compound that promotes generation of a protective barrier; and a selective coating superficial to the intermediate protective layer, having a distribution of molecules that respond to presence of the analyte, superficial to the sensing layer. Thus, a filament can comprise one or more regions, morphologies (examples of which are shown in FIGS. 3A-3H, with elements 118a-118h), compositions, and/or configurations as described in U.S. Pub. No. 2014/0275897, entitled "On-Body Microsensor for Biomonitoring" and filed on 14 Mar. 2014 and/or U.S. App. No. 62/025,174, and entitled "System for Monitoring Body Chemistry" and filed on 16 Jul. 2014, which are each incorporated herein in their entirety by this reference. However, the filament can additionally or alternatively comprise any other suitable region, composition, morphology, and/or configuration.

1.1.2 System—Electronics Subsystem

[0043] The electronics subsystem 120 functions to receive analog signals from the microsensor 116 and to convert them into digital signals to be processed by a microprocessor 113 of the electronics subsystem 120. In receiving signals, processing signals, regulating function, storing data, and/or transmitting data, the electronics subsystem 120 preferably includes a microprocessor 113 interfacing with one or more of: a signal conditioning module 122, a power management module 124, an impedance detection module 126, a storage module 127, and a transmitting unit 130, as shown in FIG. 4. However, the electronics subsystem 120 can additionally or alternatively include any other suitable modules configured to facilitate signal reception, signal processing, and data transfer in an efficient manner.

[0044] The microprocessor 113 preferably includes memory and/or is coupled to a storage module 127 (e.g., flash storage). The microprocessor 113 can also include and/or be coupled to a clock/watchdog module (which can be incorporated into a microcontroller unit) for control of timing between different functions of the electronics subsystem 120. The microprocessor 113 functions to process received signals, enable power distribution, enable impedance monitoring, and enable data transmission from the electronics subsystem 120, in relation to other portions of the electronics subsystem 120 described below; however, the microprocessor 113 can alternatively or additionally be configured to perform any other suitable function.

[0045] The signal conditioning module 122 functions to preprocess signals detected and received using the microsensor 116, thereby producing conditioned data prior to processing at the processing subsystem 160. The signal conditioning module 122 can include one or more of: a signal multiplexer, an analog front end, an amplifier (e.g., a variable gain amplifier), a filter (e.g., low pass filter, high pass

filter, band pass filter, etc.), an analog-to-digital converter (ADC), and a digital-to-analog converter (DAC). In one variation, as shown in FIG. 4, the signal conditioning module 122 comprises a multiplexer 22 in communication with the microsensor 116, wherein the multiplexer 22 is configured to communicate an output to an analog front end 23 that interfaces the microsensor 116 with an ADC 24 by way of a variable gain amplifier 25 coupled to a filter 26. In a specific example of this variation, the analog front end 23 circuitry is configured with a shifted potential different than a reference potential of the reference electrode 14 of the microsensor 116, wherein the shifted potential is different (e.g., -2V to 2V different) from the reference potential of the reference electrode 14. The configuration involving a difference between the shifted potential and the reference potential can allow the system 100 to drive redox reactions at the surface of the microsensor 110. However, in alternative variations of the specific example, the analog front end (or any other element of the signal conditioning module 122) can be configured with any other suitable potential relative to potentials of electrodes of the microsensor 116.

[0046] In more detail, the multiplexer 22 of the signal conditioning module 122 is preferably configured to receive multiple signals from the microsensor 116 (e.g., from sub-arrays of the array of filaments 117) and to forward the multiple signals received at multiple input lines in a single line at the analog front end. The multiplexer 22 thus increases an amount of data that can be transmitted within a given time constraint and/or bandwidth constraint. The number of input channels to the multiplexer 22 is preferably greater than or equal to the number of output channels of the microsensor 116, and can have any suitable relationship between the number of input lines into the multiplexer 22, select lines of the multiplexer, and output lines from the multiplexer 22. In some variations, the multiplexer 22 can include a post-multiplexer gain in order to reduce capacitance values of the analog front end 23 coupled to the multiplexer 22, and which can also be used to limit a number of amplifiers of the electronics 120, such that a single amplifier is coupled to the multiplexer 22 (as opposed to amplifiers coupled to each individual sensor); however, the multiplexer 22 can alternatively not include any gain producing elements. In some variations, the multiplexer 22 can additionally or alternatively include high frequency and/or low frequency limiting elements. However, the multiplexer 22 can additionally or alternatively be configured in any other suitable manner. Furthermore, in alternative variations, the signal conditioning module 122 can omit a multiplexer and/or comprise or omit any other suitable element.

[0047] In variations, an interface between the microsensor 116 and other elements of the electronics subsystem 120 can be configured in a manner that prevents or otherwise reduces leakage current effects due to a redox potential of the microsensor 116 in relation to other elements electronics subsystem 120. In a first configuration, a leakage current effect can result when a diode to ground (e.g., an ESD-diode to ground) is configured at an interface between the microsensor 116 and a multiplexer 22, as shown in FIG. 5A. To prevent or otherwise reduce the leakage current effect, a set of diodes 70, comprising a first diode 71 (e.g., a first ESD-diode) and a second diode 72 (e.g., a second ESD-diode), configured at an interface between the microsensor 116 and the multiplexer 22 can be coupled to an element 73 (e.g., inductor, ferrite bead, resistor, etc.) that provides a

high resistance to transient voltage spikes and directs any discharge through the second diode 72 to ground (instead of damaging the electronics subsystem 120), as shown in FIG. 5B. The multiplexer 22 can also comprise a switch 75, as shown in FIG. 5C, that allows altering of potentials within the analog front end 23. As shown in FIG. 5C, eliminating a voltage difference (i.e., between V_1 and V_2) eliminates or otherwise reduces leakage currents that can affect readings from the microsensor 110.

[0048] The power management module 124 functions to provide dynamic modulation of power transfer to and from elements of the microsensor patch 110, in a manner that enables efficient operation of the system 100. Preferably, the power management module 124 interfaces with a battery 138 and elements of the transmitting unit 130 requiring power (e.g., by way of a microprocessor 113, as shown in FIG. 4), as described in further detail below. Additionally, the power management module 124 can further interface with an external processing element of the processing subsystem 160, such that the power management module 124 can be at least partially implemented in firmware. In one such variation of the power management module 124, wherein power management is achieved in firmware, the power management module 124 can be configured to anticipate power requirements of one or more elements, and to automatically operate at the highest demanded power mode (e.g., voltage) required, while never dropping below a minimum power level required by the elements. The power management module 124 can also facilitate efficient switching of components to an "off" state when not needed, in order to contribute to lower current consumption. Additionally or alternatively, the power management module 124 can be configured to dynamically trigger high current draw sensing components (e.g., the impedance detection module 126) to an "on" state, only when needed, by monitoring other system components (e.g., voltage of a counter electrode 13).

[0049] In an example, as shown in FIG. 6A, a group of elements requiring different operating power levels can be coupled to the power management module 124, and the power management module 124 can output power at the highest operating power level anticipated among the elements. Disparate elements can also set a minimum level of power they require, and as elements vary their power requirements, the power management module 124 can then automatically adjust power output such that a power level provided never drops below the lowest power level required. In this variation, elements of the microsensor patch 110 requiring power are thus dynamically provided with their highest demanded power level, to substantially limit energy wasted by the system 100 and to satisfy power level requirements of all running elements. In another variation of the power management module 124, wherein power management is achieved in firmware, the power management module 124 can be configured to detect elements requiring power, and to automatically operate at the highest demanded power mode (e.g., voltage) required. In an example, a group of elements requiring different operating voltages can be detected, and the power management module 124 can output power at the highest operating voltage detected. As elements vary their voltage requirements, the power management module 124 can then automatically adjust voltage output to meet the highest demanded voltage. In this variation, elements of the microsensor patch 110 requiring power are thus

dynamically provided with their highest demanded voltage, to substantially limit energy wasted by the system 100.

[0050] In other variations, power management can be achieved by the power management module 124 without implementation in firmware, such that power management occurs in circuitry. In these other variations, an example of which is shown in FIG. 6B, power management can comprise providing a set amount of power to elements requiring power, and completely eliminating power transfer to elements not requiring power. The system 100 can, however, comprise any other suitable variation of the power management modules 124.

[0051] In relation to the power management module 124, the electronics subsystem 120 can comprise a battery 138, which functions to serve as a power source for the electronics subsystem 120. The battery 138 is preferably coupled to a fuel gage 38 and a charging detection module 39, each of which is coupled to the microprocessor 113 (described in further detail below). The battery 138 is preferably a lithium-ion battery that is configured to be rechargeable, but can be any appropriate rechargeable battery (e.g., nickel-cadmium, nickel metal hydride, or lithium-ion polymer). Alternatively, the battery 138 may not be a rechargeable battery. Preferably, the battery 138 is configured to have a profile with a low aspect ratio, contributing to a thin form factor of the microsensor patch 110. However, the battery 138 can be configured to have any appropriate profile such that the battery 130 provides adequate power characteristics (e.g., cycle life, charging time, discharge time, etc.) for the system 100. In some variations, a thin-film battery can be integrated with the microsensor patch 110 in order to facilitate substantially continuous analyte detection by the system 100, independent of the microprocessor 113 and digital electronics of the electronics subsystem 120.

[0052] In embodiments where the battery 138 is rechargeable, the electronics subsystem 120 can also comprise a charging coil 140 that functions to provide inductive charging for the battery 138, and a charging detection module 39, in communication with the microprocessor 113, that enable detection of charging of the battery 138. The charging coil 140 is preferably coupled to the battery 138 and converts energy from an electromagnetic field (e.g., provided by an element of a base station, as described in further detail below), into electrical energy to charge the battery 138. Inductive charging provided by the charging coil 140 thus facilitates user mobility while interacting with the system 100. In alternative variations, however, the charging coil 140 can altogether be omitted (e.g., in embodiments without a rechargeable battery), or replaced by a connection configured to provide wired charging of a rechargeable battery.

[0053] Additionally or alternatively, in some variations, the microsensor patch 110 can comprise a semi-active or fully-active power cell (e.g., implementing microelectromechanical system elements) that functions to absorb and/or release generated energy from any one or more of: body heat of the user, body movement of the user (e.g., with piezoelectric elements, with capacitive elements), static voltage from the environment of the user, light in the environment of the user (e.g., using solar cells), magnetic energy flux, galvanic differentials, and any other suitable energy source to provide secondary backup energy for the system 100.

[0054] The impedance detection module 126 is in communication with the signal conditioning module 122 and the power management module 124, and functions to enable

detection of a proper interface between the microsensor 116 and body fluid (e.g., interstitial fluid) of the user. In facilitating monitoring of impedance, the impedance detection module 126 can thus provide signals that indicate that the microsensor patch 110 is properly coupled to the user (e.g., interfacing with interstitial fluid and experiencing an ~80% moisture environment) or improperly coupled to the user (e.g., not interfacing properly with interstitial fluid and experiencing a low-moisture environment). Signals from the impedance detection module 126 can further be used to trigger an error correction action (e.g., notification for the user to reapply the microsensor patch 110, automatic manipulation of the microsensor patch 110 to re-establish interface with body fluid, etc.). In one variation, as shown in FIG. 4, the impedance detection module can comprise electronic circuitry configured to communicate with the multiplexer 22, the ADC 24, and the power management module 124, in receiving an impedance signal from the microsensor 116. However, the impedance detection module 126 can additionally or alternatively be configured relative to other elements of the electronics subsystem 120 in any other suitable manner.

[0055] In generating the impedance signal, the impedance detection module 126 can be configured to detect impedance between two electrodes of the array of filaments 117 in response to an applied voltage provided in cooperation with the power management module 126 and the microprocessor 113. In one variation, wherein the microsensor 116 comprises a first working electrode 11, a second working electrode 12, a counter electrode 13, and a reference electrode, the impedance detection module 126 can be configured to detect impedance from two of the first working electrode 11, the second working electrode 12, the counter electrode 13, and the reference electrode 14, examples of which are shown in FIG. 7. In a specific example, an applied signal can be injected into the system in a working electrode and detected in the reference electrode 14. However in other configurations of the microsensor 116, the impedance detection module 126 can be configured to detect impedance from electrodes of the microsensor 116 in any other suitable manner.

[0056] In relation to the applied voltage used for generation and reception of the impedance signal (i.e., for purposes of perturbation), the electronics subsystem 120 is preferably configured to provide an applied voltage waveform having a characteristic value (e.g., average value) near the operating potential of the signal conditioning module 122 of the electronics subsystem 120. In a variation wherein the signal conditioning module 122 (e.g., an analog front end 23 of the signal conditioning module 122) operates at a shifted potential relative to a potential of an electrode of the microsensor 116 (e.g., a reference potential of a reference electrode), the applied voltage waveform preferably has a characteristic value (e.g., average value) near or equal to that of the shifted potential, in order to improve stability of the microsensor 110 when switching back to a current sensing mode (i.e., the primary detection mode). The offset (i.e., shifted potential) is configured to reduce or minimize any disruption to signal integrity when the microsensor 110 is switched from a current sensing mode to an impedance detection mode, and then back to a current sensing mode. In a specific example, as shown in FIG. 8, the applied voltage waveform is shifted about a characteristic value and has a frequency from 50-200 kHz, in relation to a shifted potential of the analog front end 23 relative to the reference electrode 14. However, the

applied voltage can alternatively have any other suitable characteristics (e.g., characteristic voltage values, frequencies, etc.) defined in relation to the operating potential(s) of any other suitable element of the electronic subsystem 120 related to the microsensor 116.

[0057] In relation to triggering of a measurement using the impedance detection module 126, triggering can occur with any suitable frequency (e.g., in relation to the lifespan of usage of the system 100), any suitable regularity (e.g., at regular time intervals, at irregular time intervals, etc.), and/or upon any suitable triggering event. In one variation, the impedance detection module 126 can be configured to provide an impedance signal in association with monitoring of an electrode (e.g., monitoring voltage of the counter electrode 13) of the microsensor 116, wherein detection of an out-of-range parameter (e.g., voltage) of the electrode triggers the applied voltage waveform and generation of an impedance signal. As such, the electronics subsystem 120 and the processing subsystem 160 (described further below) can be configured to cooperate in continuously detecting a voltage parameter of the counter electrode 13, and the electronics subsystem 120 can be configured to apply the applied voltage waveform and detect the impedance signal when the voltage parameter of the counter electrode satisfies a voltage threshold condition.

[0058] Additionally or alternatively, in another variation, the impedance detection module 126 can be configured to provide an impedance signal upon initial application of the system 100 to the body of the user. Additionally or alternatively, in another variation, the impedance detection module 126 can be configured to provide impedance signals at regular time intervals (e.g., once every hour) over the course of use of the system 100 by the user. Additionally or alternatively, in relation to other sensors (e.g., of a mobile computing device associated with the user and the system 100, of a wearable computing device associated with the user and the system 100, of the system 100, etc.) the impedance detection module 126 can be configured to provide an impedance signal in response to a sensor signal that indicates performance of an action by the user. For instance, monitoring of signals provided by an accelerometer and/or gyroscope can be used to indicate that the user is exercising, and that an impedance measurement should be taken (e.g., during exercise, after exercise, etc.) to ensure proper coupling of the system 100 to the user. In another example, monitoring of body temperature of the user can be used to indicate that the user is showering, and that an impedance measurement should be to ensure proper coupling of the system 100 to the user. The impedance detection module 126 can, however, be configured in any other suitable manner.

[0059] The impedance detection module 126 can further be used to generate notifications pertaining to impedance signal measurements that indicate improper coupling. For instance, a notification can be generated (and transmitted to a mobile computing device of the user) in response to detection of unsuitable impedance derived from comparison between the impedance signal and an impedance threshold condition. However, use of the impedance signal in performing an error correction action can be performed in any other suitable manner.

[0060] The transmitting unit 130 functions to receive signals generated by the microsensor patch 110 (e.g., by way of the microprocessor 113), and to interface with at least one

of a mobile computing device 150, a data processing and/or storage module (e.g., a module external to an on-board storage module, a cloud-based computing module, etc.) by outputting signals based on at least one analyte parameter. The transmitting unit 130 thus cooperates with other elements of the electronics subsystem 120 to transmit signals based on sensed analyte parameters, which can be used to facilitate analyses of the user's body chemistry. In variations, the transmitting unit 130 includes an antenna 132, a radio 134 coupling the antenna to the microprocessor 113, and can additionally or alternatively include a linking interface 136 (e.g., wireless or wired interface, as described in further detail below).

[0061] Preferably, the transmitting unit 130 and the microsensor patch 110 are integrated as a cohesive unit; however, the transmitting unit 130 and the microsensor patch 110 can alternatively form a modular unit, wherein one of the transmitting unit 130 and the microsensor patch 110 is disposable, and wherein one of the transmitting unit 130 and the microsensor patch 110 is reusable. In variations of the microsensor patch 110 and the transmitting unit 130, elements of the microsensor patch 110 aside from the microsensor 116 can alternatively be integrated with the transmitting unit 130, such that the transmitting unit 130 is configured to be reusable and the microsensor 116 of the microsensor patch 110 is configured to be disposable. Modularity in the system 100 is described in further detail in relation to the housing 190 below.

[0062] Additionally, the transmitting unit 130 is preferably configured to output signals based on at least one analyte parameter characterizing body chemistry continuously over the lifetime usage of the transmitting unit 130; however, the transmitting unit 130 can alternatively be configured to output signals based on at least one analyte parameter at a set of time points (e.g., minutes, hours, days). Still alternatively, the transmitting unit 130 can be configured to output signals in a manner that does not interfere with other operations (e.g., signal collection operations) of the electronics subsystem 120. In one such example, the transmitting unit 130 can be configured to stop signal transmission whenever the ADC 24 is collecting signal data from the microsensor 116, in coordination with timing enabled by a clock/watchdog module associated with the microprocessor 113. In variations, the transmitting unit 130 can be further configured to output signals upon a user prompt, and/or can comprise a variable sampling rate. For example, the sampling rate can be lower when user is asleep, higher during activity (e.g., exercise), higher when there is a sudden change in a value, higher in response to other stimuli (e.g., if glucose spikes, sampling rate increases for all analytes).

[0063] The antenna 132 of the transmitting unit 130 functions to convert electrical signals from the microsensor patch 110 into radio waves, to facilitate communication with one or more devices external to the microsensor patch 110 and/or transmitting unit 130 assembly (e.g., by a Bluetooth Low Energy connection). The antenna 132 preferably interfaces with a radio 134 coupled to the microprocessor 113, as shown in FIG. 4, but can additionally or alternatively interface with other elements of the transmitting unit 130. The antenna is preferably an omnidirectional antenna that radiates radio wave power uniformly primarily in one plane, with the power decreasing with elevation angle relative to the plane; however, the antenna can alternatively be an isotropic antenna that has a spherical radiation pattern. Other

variations of the antenna can include any appropriate antenna that can be integrated with the form factor of the transmitting unit, while providing appropriate communication with external devices.

[0064] The radio 134 functions to transmit and receive signals from the antenna 132, and also facilitates communication with elements of the transmitting unit 130 and external devices. The radio 134 and the antenna 132 can additionally or alternatively be supplemented with a linking interface 136, as described in further detail below, but can additionally or alternatively interface with other elements of the electronics subsystem 120.

[0065] The linking interface 136 functions to transmit an output of at least one element of the microsensor patch 110/transmitting unit 130 assembly to a mobile computing device 150. Additionally, the linking interface 136 can function to transmit and output of at least one element of the microsensor patch 110 and transmitting unit 130 assembly to another element external to the microsensor patch 110 and transmitting unit 130. Preferably, the linking interface 136 is a wireless interface; however, the linking interface 136 can alternatively be a wired connection. In a first variation, the linking interface 136 can include a first module that interfaces with a second module included in a mobile computing device 150 or other external element (e.g., wrist-borne mobile computing device, head-mounted mobile computing device), wherein data or signals (e.g., microsensor or transceiver outputs) are transmitted from the transmitting unit 130 to the mobile computing device 150 or external element over non-wired communications. The linking interface 136 of the first variation can alternatively implement other types of wireless communications, such as 3G, 4G, radio, or Wi-Fi communication. In the first variation, data and/or signals are preferably encrypted before being transmitted by the linking interface 136. For example, cryptographic protocols such as Diffie-Hellman key exchange, Wireless Transport Layer Security (WTLS), or any other suitable type of protocol can be used. The data encryption can also comply with standards such as the Data Encryption Standard (DES), Triple Data Encryption Standard (3-DES), or Advanced Encryption Standard (AES). In variations with data encryption, data can be unencrypted upon transmission to the mobile computing device 150 associated with the user. However, in an alternative variation, data can remain encrypted throughout transmission to a mobile computing device (associated with the user, not associated with the user) and unencrypted at another module of a processing subsystem 160 (e.g., unencrypted in the cloud), wherein information derived from analysis of the data can then be transmitted back to the mobile computing device associated with the user in a secure manner. In this variation, a user can thus pair his/her microsensor patch 110 with a mobile computing device unassociated with the user for transmission of encrypted data, and then later receive personalized body information at his/her own mobile computing device 150 after processing in the cloud.

[0066] In a second variation, the linking interface 136 is a wired connection, wherein the linking interface 136 includes a wired jack connector (e.g., a 1/8" headphone jack, a USB connection, a mini-USB connection, a lightning cable connection, etc.) such that the transmitting unit 130 can communicate with the mobile computing device 150 and/or an external element through a complementary jack of the mobile device and/or external element. In one specific

example of the linking interface 136 that includes a wired jack, the linking interface is configured only to transmit output signals from the transmitting unit 130/microsensor patch 110. In another specific example, the linking interface 136 is configured to transmit data to and from at least one element of transmitting unit 130/transdermal path 110 assembly and a mobile computing device 150. In this example, the linking interface 136 can transmit output signals into the mobile computing device 150 through an input of the jack of the mobile computing device 150 and can retrieve data from an output of the jack of the mobile computing device 150. In this example, the linking interface 136 can communicate with the mobile computing device 150 via inter-integrated circuit communication (I2C), one-wire, master-slave, or any other suitable communication protocol. However, the linking interface can transmit data in any other way and can include any other type of wired connection that supports data transfer between the transmitting unit 130 and/or microsensor patch 110, and the mobile computing device 150.

[0067] As noted above, the electronics subsystem 120 can include any other suitable module(s) and/or be configured in any other suitable manner. For instance, the electronics subsystem 120 can include or be in communication with an actuator configured to automatically perform an action (e.g., vibration, provision of a biasing force) that biases the microsensor into communication with interstitial fluid of the user, in response to detection of unsuitable impedance derived from comparison between an impedance signal and an impedance threshold condition.

1.1.3 System—Housing

[0068] The housing 190 supports the microsensor 116 and the electronics subsystem 120, and functions to facilitate robust coupling of the microsensor patch 110 to the user in a manner that allows the user to wear the microsensor patch 110 for a sufficient period of time (e.g., one week, one month, etc.). The housing 190 can also function to protect elements of the microsensor patch 110 from physical damage over the lifetime usage of the microsensor patch 110. Preferably, at least one portion of the housing 190 is flexible to facilitate adhesion to the user and compliance with skin of the user as the user moves in his/her daily life; however, at least a portion of the housing 190 can alternatively be rigid in order to provide more robust protection against physical damage. In an embodiment where a portion of the housing 190 is flexible, other elements of the microsensor patch 110 can also be flexible (e.g., using a thin film battery, using flexible electronics, etc.) to facilitate adhesion to the user and compliance as the user moves about in his/her daily life. In one variation, the housing 190 can comprise a single unit that entirely houses the microsensor 116 and the electronics subsystem 120. In this variation, the housing 190 can be configured to couple to the user using any suitable coupling mechanism (e.g., adhesive coupling mechanism, strap-based coupling mechanism, etc.). However, in other variations, the housing 190 can alternatively be modular and comprise a set of portions, each portion configured to enable coupling of the microsensor 116 to the user and/or to house elements of the electronics subsystem 120. Modularity of the housing 190 can thus allow portions of the system 100 to be disposable and/or reusable.

[0069] In one such modular variation of the housing 190, as shown in FIG. 9, the housing can comprise a first housing

portion 191 and a second housing portion 196, wherein the first housing portion 191 is configured to facilitate coupling of filaments of the microsensor 116 to the user, and the second housing portion 196 is configured to house elements of the electronics subsystem 120 and to couple the electronics subsystem 120 to the microsensor 116 by way of the first housing portion 191. As such, the first housing portion 191 and the second housing portion 196 of this variation are preferably configured to mate with each other in a complementary manner (e.g., with a male-female coupling mechanism, with a magnetic coupling mechanism, with a latch-based coupling mechanism, with a lock-and-key based coupling mechanism, etc.). In a specific example, as shown in FIGS. 10A-10B, the first housing portion 191' includes an opening 192', and a second housing portion 196' is insertable into the opening of the first housing portion in a first configuration, wherein coupling between the first housing portion 191' and the second housing portion 196' provides a hermetic seal between the first housing portion 191 and the second housing portion 196. In more detail, as shown in FIG. 10C, the first housing portion 191 can include an o-ring 193 (e.g., an o-ring molded onto the material of the first housing portion) at a perimeter of the opening 192, and a perimeter region of the second housing portion 196 can include a recessed region 197 that interfaces with the o-ring 193 in a manner that provides a hermetic seal. In this specific example, the opening 192 and the second housing portion 196 each have substantially circular footprints; however, the opening 192 and the second housing portion 196 can additionally or alternatively have any other suitable footprints or be configured in any other suitable manner.

[0070] In the specific example, as shown in FIGS. 10A-10B, the first housing portion 191' can comprise an adhesive substrate 91 having a microsensor opening 92, a microsensor interface substrate 93 superior to the adhesive substrate and configured to pass the microsensor 92 through the microsensor opening 92, a coupling ring 94 configured to retain the position of the microsensor interface substrate 93 relative to the adhesive substrate 91 and to provide an interface for mating with the second housing portion 196, and a flexible cover 95 ensheathing the coupling ring 94, coupled to the adhesive substrate 91, and configured to maintain coupling between the adhesive substrate 191, the microsensor interface substrate 93, and the coupling ring 94. In relation to the configuration described above, the adhesive substrate 91 is configured to facilitate adhesion of the microsensor patch 110 to the user at an inferior surface of the adhesive substrate, and the flexible cover 95 is configured to provide the opening 192' that receives the second housing portion 192.

[0071] The second housing portion 196 of the specific example is rigid, and configured to form a shell about the electronics subsystem 120, while including openings that provide access for a set of contacts 98 that interface the electronics subsystem 120 with the microsensor interface substrate 93 when the first housing portion 191 is coupled to the second housing portion 196. In relation to the microsensor interface substrate 93 of the first housing portion 191, and in relation to a circular (or otherwise axially symmetric) configuration of an interface between the second housing portion 196 and the opening 192 of the first housing portion 191, the microsensor interface substrate 93 of the specific example can include a circular printed circuit board comprising a set of concentric ring contacts 97, as shown in FIG.

10A, that interface electronics of the second housing portion 196 with filaments of the microsensor 116. As such, the set of contacts 98 (e.g., digital contacts) of electronics of the second housing portion 196 can properly interface with the microsensor 116 in any rotational position of the second housing portion 196 within the first housing portion 191, as shown in FIG. 10B. In alternative variations of this specific example however, orientation-unspecific coupling between the first housing portion 191 and the second housing portion 196 can be achieved in any other suitable manner. In still alternative variations of this specific example, the first housing portion 191 and the second housing portion 196 can be configured to couple with a set orientation in order to ensure proper communication between the microsensor 116 and the electronics subsystem 120.

[0072] In variations of the housing 190 comprising a first housing portion 191 and a second housing portion 196, the first housing portion 191 and the second housing portion 196 can be coupled together and/or coupled to the user by way of a patch applicator 180, as described in further detail below. Furthermore, other variations of modularity can comprise any other suitable distribution of the microsensor 116 and elements of the electronics subsystem 120 across portions of the housing in any other suitable manner. For instance, in one such variation, the microsensor 116, the multiplexer 22, and the analog front end 93 of the electronics subsystem 120 can be coupled to a separate battery (e.g., a thin film battery) within a disposable portion of the housing 190, and other elements of the electronics subsystem 120 can be supported by a reusable portion of the housing 190. The system 100 can, however, comprise any other suitable distribution of elements across the housing 190 in a modular fashion.

1.2 System—Processing Subsystem

[0073] The processing subsystem 160 is in communication with the electronics subsystem 120 and functions to generate analyses pertaining to the user's body chemistry, and to transmit information derived from the analyses to the user at an electronic device associated with the user. As shown in FIG. 1, the processing subsystem 160 can be implemented in one or more of: a computer machine, a remote server, a cloud computing system, a microprocessor, processing hardware of a mobile computing device (e.g., smartphone, tablet, head-mounted mobile computing device, wrist-borne mobile computing device, etc.) and any other suitable processing system. In one variation, the processing subsystem 160 comprises a first module 161 configured to generate an analysis indicative of an analyte parameter of the user and derived from a signal stream from the microsensor 116 and an impedance signal from the electronics subsystem 120. Additionally, in this variation, the processing subsystem 160 comprises a second module 162 configured to render information derived from the analysis at an electronic device (e.g., mobile computing device 150) associated with the user, thereby facilitating monitoring of body chemistry of the user. In this variation, the modules of the processing subsystem 160 can be implemented in a hardware module and/or a software module. In variations, a software module 163 can be implemented, at least in part, as a native software application executing on a mobile computing device 150 associated with the user, wherein the user has a user account associated with the native software application.

[0074] In more detail, the software module **163** functions to analyze an output provided by the transmitting unit **130** of the electronics subsystem **120**, and to communicate an analysis of the output back to the user, so that the user can monitor his/her body chemistry. Preferably, the software module **163** analyzes at least one analyte parameter in order to determine a metric providing information about a user's body chemistry. In one variation, the software module can determine that a body analyte parameter (e.g., glucose level) of the user is too low or less than ideal, and facilitate a behavior change in the user by providing a body chemistry metric indicating a hypoglycemic state. In this variation, the software module can additionally determine that the body analyte parameter (e.g., glucose level) of the user is within a proper range based on a determined metric. The software module of this variation can additionally determine that the body analyte parameter (e.g., glucose level) of the user is too high and facilitate a behavior change in the user by providing a body chemistry metric indicating a hyperglycemic state.

[0075] In another example, the software module can analyze an output provided by the transmitting unit **130** based on a set of parameters for multiple analytes characterizing a user's body chemistry, at a set of time points, and determine at least one metric based on the set of parameters at the set of time points. The software module can then determine and output at least one of a temporal trend in a metric, a temporal trend in an analyte parameter, absolute values of a metric, changes in value of a metric, absolute values of an analyte parameter, and changes in value of an analyte parameter. The software module **163** in this example can further be configured to communicate a suggestion to the user based on an analysis determined from the set of parameters for multiple analytes.

[0076] The software module preferably incorporates at least one of user health condition, user characteristics (e.g., age, gender, ethnicity), and user activity in analyzing an output provided by the transmitting unit **130**. In one specific example, if a user sets a desired body glucose level range, which is entered into the software module, the software module can be configured to facilitate provision of alerts notifying the user of short-term risks (e.g., diabetic crash), long-term risks (e.g., worsening diabetic condition), and risk of exiting the desired body glucose level range. In another specific example, the software module can compare analyte parameters and/or a metric characterizing the user's body chemistry to other users with similar health conditions or characteristics (e.g., age, gender, ethnicity). In yet another example, the software module can be able to correlate at least one analyte parameter or metric to a user activity, such that the user is provided with information relating a value of the analyte parameter and/or metric to an activity that he or she has performed. The software module can additionally or alternatively provide an analysis that includes any other health- and/or user-related information that can be useful in treating, maintaining, and/or improving a health condition of a user.

[0077] As shown in FIGS. **1**, **11A**, and **11B**, the software module can be implemented, at least in part, as an application executable on a mobile computing device **150**. As described above, the mobile computing device **150** is preferably a smartphone but can also be a tablet, laptop computer, PDA, e-book reader, head-mounted computing device, smart-watch, or any other mobile device. The soft-

ware module can alternatively be an application executable on a desktop computer or web browser. The software module preferably includes an interface that accepts inputs from the user (e.g., user health condition, user characteristics, user activity), and uses these inputs in analyzing an output provided by the transmitting unit **130**. Preferably, the software module also includes an interface that renders an analysis based on sensed analytes and/or user inputs in some form. In an example, the software module includes an interface that summarizes analyte parameter values in some manner (e.g., raw values, ranges, categories, changes), provides a trend (e.g., graph) in at least one analyte parameter or body chemistry metric, provides alerts or notifications, provides additional health metrics, and provides recommendations to modify or improve body chemistry and health metrics. In another example, the software module can implement two interfaces: a first interface accessible by a user, and a second interface accessible by a health care professional servicing the user. The second interface can provide summarized and detailed information for each user that the health care professional interacts with, and can further include a message client to facilitate interactions between multiple users and the health care professional. The software module can additionally or alternatively access a remote network or database containing health information of the user. The remote network can be a server associated with a hospital or a network of hospitals, a server associated with a health insurance agency or network of health insurance agencies, a server associated with a third party that manages health records, or any other user- or health-related server or entity. The software module can additionally or alternatively be configured to accept inputs from another entity, such as a healthcare professional, related to the user.

[0078] The software module **163** can additionally or alternatively execute fully or in part on a remote server. In a first variation, the software module can be a cloud-computing-based application that performs data analysis, calculations, and other actions remotely from the mobile computing device **150**. In one example of the first variation, the mobile computing device **150** can receive an output of the transmitting unit **130** via the linking interface **136** and then transfer the output to the remote server upon which the software module executes. In the first variation, signals are preferably transferred via a wireless connection, such as a Bluetooth connection, 3G or 4G cellular connection, and/or via a Wi-Fi internet connection. In another example of the first variation, a mobile computing device **150** can function to transmit data to and/or receive data from the software module. In a second variation, the software module can include a first software component executable on a mobile computing device **150**, such as an application that manages collection, transmission, retrieval, and/or display of data. In the second variation, the software module can further include a second software component that executes on the remote server to retrieve data, analyze data, and/or manage transmission of an analysis back to the mobile computing device **150**, wherein the first software component manages retrieval of data sent from the second software component and/or renders a form of the analysis on a display of the mobile computing device **150**. However, the software module can include any number of software components executable on any mobile computing device **150**, computing device, and/or server and can be configured to perform any other function or combination of functions.

[0079] As shown in FIG. 12A, the software module 163 can further be integrated with a notification module 165 configured to provide an alert or notification to a user and/or health care professional based on the analysis of the output. The notification module 165 functions to access an analysis provided by the software module and to control transmission of a notification 166 to at least one of a user and a healthcare profession interacting with the user. In one variation, the notification module 165 receives an analysis of the software module being executed on a mobile computing device 150, and generates a notification 166 based upon the analysis. In this variation, a form of the analysis is preferably transmitted from the software module, executing on the mobile computing device 150, to the notification module 165, wherein the mobile computing device 150 accesses the analysis either from the software module executing on the mobile computing device 150 or from the software module executing on a remote server and in communication with the mobile computing device 150. The notification module 165 preferably controls transmission of the notification 166 to the user, such as by triggering a display of the mobile computing device 150 to display a form of the notification, or by generating and/or transmitting an email, SMS, voice-mail, social media platform (e.g., Facebook or Twitter) message, or any other message accessible by the user and which contains the notification 166. The notification module 165 can also convey the notification 166 by triggering a vibration of the mobile device 160, and/or by altering the state (i.e., ON or OFF) of one or more light sources (e.g., LEDs) of the mobile computing device 150. However, the notification module 165 can alternatively manage the transmission of any other information and function in any appropriate manner.

[0080] The notification 166 preferably contains information relevant to a body chemistry status of the user. The notification 166 can additionally include an explicit directive for the user to perform a certain action (e.g., eat, rest, or exercise) that affects the body chemistry of the user. Therefore, the notification 166 preferably systematically and repeatedly analyzes a body chemistry status of the user based on at least one analyte parameter of the user and provides an alert and/or advice to manage and monitor a user's body chemistry substantially in real time. In one example, the notification 166 can further include information related to what or how much to eat, where and how long to run, level of exertion, and/or how to rest and for how long in order to appropriately adjust body chemistry. In other examples, the notification 166 can include any appropriate information relevant to monitoring a body chemistry metric of the user.

[0081] In still other examples, as shown in FIG. 12B, the notification 166 can indicate one or more of: a current level of a measured analyte (e.g., represented in hue, represented in saturation, represented in intensity, etc. of a graphical rendering); a trending direction for the level of the measured analyte (e.g., represented in a feature gradient within a graphical rendering); a lower bounding level and an upper bounding level between which the level of the measured analyte is traversing; a trending direction of a level of a measured analyte (e.g., represented in an arrow of a graphical rendering); a quantification of a level of a measured analyte (e.g., represented as rendered text); a summary of a level of a measured analyte (e.g., represented as rendered text); a percent of time within a time duration (e.g., one day)

that the level of the measured analyte is within a target range (e.g., healthy range); and historical behavior of a level of a measured analyte (e.g., represented as historical "ghosting" of a rendering based upon a previous analyte level).

[0082] Additionally or alternatively, in still other examples, as shown in FIG. 12C, the notification 166 can include a graphical rendering that shows analyte data from past to present using a line graph representation, wherein an amount (e.g., concentration) of the analyte is represented along a first axis and time is represented along a second axis. In these examples, the graphical rendering can further include a "predicted region" based upon the analysis of the processing subsystem 160, wherein the predicted region 66 depicts a prediction of where the analyte level will be at a future time point, and a width of the predicted region 66 indicates confidence in the prediction.

[0083] In relation to the processing subsystem 160 and analyses generated at the processing subsystem 160, the processing subsystem 160 can be coupled to or comprise a data storage unit 170, as shown in FIG. 13. The data storage unit 170 functions to retain data, such as an analysis provided by a software module, a notification 166, and/or any other output of any element of the system 100. The data storage unit 170 can be implemented with the microsensor patch 110, transmitting unit 130, mobile computing device 150, personal computer, web browser, external server (e.g., cloud), and/or local server, or any combination of the above, in a network configured to transmit, store, and receive data. Preferably, data from the data storage unit 170 is automatically transmitted to any appropriate external device continuously; however, data from the data storage unit 170 can alternatively be transmitted only semi-continuously (e.g., every minute, hourly, daily, or weekly). In one example, data generated by any element can be stored on a portion of the data storage unit 170 when the linking interface 136 is not coupled to an element external to the microsensor patch 110/transmitting unit 130 assembly. However, in the example, when a link is established between the linking interface 136 and an external element, data can then be automatically transmitted from the storage unit 170. In other examples, the data storage unit 170 can alternatively be prompted to transmit stored data by a user or other entity. Operation modes related to device pairing and information transfer are further described in relation to the base station of Section 1.4 below.

1.3 System—Applicator

[0084] As shown in FIG. 1, the system 100 can further comprise a patch applicator 180, which functions to facilitate application of at least one of the microsensor patch 110 and the transmitting unit 130. The patch applicator 180 preferably accelerates the a portion of the housing with the microsensor 116 toward skin of the user, thereby causing the microsensor 116 to penetrate skin of the user and sensing regions of the microsensor to access interstitial fluid of the user. However, the patch applicator 180 can additionally or alternatively facilitate coupling of the microsensor 116 to the user using one or more of: skin stretching, skin permeabilization, skin abrasion, vibration, and/or any other suitable mechanism, variations of which are shown in FIGS. 14A-14C. In a first variation, as shown in FIG. 15A, the patch applicator 180' can be incorporated into a first housing portion 191 of a housing 190 of the system 100 and can comprise an elastic pin 181 (e.g., spring-loaded pin) con-

figured to complement a recess of a second housing portion 196. In this variation, a normal force applied to a broad surface of the second housing portion 196 initially causes the elastic pin 181 to retract, and rebounding of the elastic pin 181 into the recess of the second housing portion 196 biases and accelerates the microsensor 116 into the skin of the user.

[0085] In a second variation, as shown in FIG. 15B, the patch applicator 180" implements elastic portions of the housing 190, which can be used to retract a housing portion with the microsensor 116 and to release the housing portion, thereby accelerating the microsensor 116 into skin of the user.

[0086] In a third variation, the patch applicator cooperates with a first housing portion 191 and a second housing portion 196, wherein the patch applicator comprises a first applicator portion configured to surround the housing 190 and interface with the second housing portion 196, and a second applicator portion configured to accelerate the second housing portion toward skin of the user. In a first specific example of the third variation, as shown in FIG. 16A, the patch applicator 180a comprises a ram-and-catch mechanism, wherein twisting of a rotatable component 83 of the patch applicator 180a transitions a plunger 84 of the patch applicator 180a from a resting configuration 84a to a loaded configuration 84b, as shown in FIGS. 16B and 16C, and pushing of the rotatable component 83 of the patch applicator 180a releases the plunger 84 back to the resting configuration 84a (as shown in FIG. 16D), thereby accelerating the microsensor 116 toward skin of the user during application of the microsensor patch 110 to the user. In more detail, in the first specific example, twisting of the rotatable component 83 transitions the plunger 84 along ramped surfaces 85 of the patch applicator 180a to the loaded configuration 84a, where the plunger 84 rests on triggers 86 of the patch applicator 180a. Then, as shown in FIG. 16D, pressing of the rotatable component 83 provides an outward biasing force on the triggers 86 (e.g., due to wedge-shaped morphology of the triggers that interacts with a complementary portion of the rotatable component 83), thereby releasing the plunger 84 to the resting configuration 84a. In this specific example, a set of ribs 87 coupled to a wall of the patch applicator 180 surrounding the plunger 84 maintain plunger alignment.

[0087] In a second specific example of the third variation, as shown in FIG. 17, the patch applicator 180b comprises an elastic component 89 housed within and coupled to a translating component 88 of the patch applicator 180b, wherein the translating component 88 comprises a plunger 84' and is configured to translate along a first axis. The patch applicator 180b further comprises a trigger 188 coupled to a biasing spring 189 and configured to translate along a second axis perpendicular to the first axis, between a holding position 188a and a releasing position 188b. In the second specific example, the translating component 88 is biased in holding position 188a, and pushing of the translating component 88 places a lateral biasing force on the trigger 188 against the biasing spring 189 (e.g., due to wedge-shaped morphology of the trigger 188 that interacts with a complementary portion of the translating component 88), thereby releasing the plunger 84' to accelerate the microsensor 116 toward skin of the user. In pushing the translating component 88, compression of the elastic component 89 creates a

reverse biasing force that automatically releases the translating component 88 toward the resting configuration 88a.

[0088] The patch applicator 180 can alternatively be configured to receive the microsensor patch 110, to stretch the skin of the user isotropically in two dimensions to facilitate application, and to push the microsensor patch 110/transmitting unit 130 assembly onto the user's stretch skin. Still alternatively, the patch applicator 180 can include any other suitable applicator, variations and examples of which are described in U.S. App. No. 62/025,174 entitled "System for Monitoring Body Chemistry" and filed on 16 Jul. 2014. Still other variations of the system 100 can entirely omit a patch applicator 180.

1.4 System—Base Station

[0089] As shown in FIG. 1, the system can include a base station 5 that functions to receive the microsensor patch 110 (e.g., within a second housing portion 196). In receiving the microsensor patch 110, the base station 5 can include alignment elements 6 (e.g., protrusions, recesses, magnetic alignment elements, etc.) that facilitate alignment of the microsensor patch 110 within the base station, as shown in FIG. 18A. The base station 5 can additionally or alternatively facilitate charging of a rechargeable battery of the microsensor patch 110 by including elements that generate an electromagnetic field that interacts with a charging coil coupled to the battery, thereby charging the battery 138. The base station 5 can additionally or alternatively be used to transition the microsensor patch between different operational states, in relation to data transfer between the microsensor patch 110, a mobile computing device 150 associated with the user, and modules of a processing subsystem 160 (e.g., cloud module) as shown in FIG. 19. In a first operation mode 5a, the transmitting unit 130 of the microsensor patch 110 and the mobile computing device 150 can pair/bond only when the second housing portion 196 of the microsensor patch 110 is in communication with the base station 5 (e.g., aligned within the base station 5). Thus, in the first operation mode 5a, the microsensor patch 110 can transmit and receive data (e.g., compact raw data compounded into a plurality of bits over Bluetooth communication). In a second operation mode 5b wherein the microsensor patch 110 is not in communication with the base station 5, the microsensor patch 110 can be configured to only transmit data (but not receive data), thereby reducing energy usage, preventing man-in-the-middle attack, and preventing tampering. As such, the second operation mode 5b prevents reading of data from the microsensor patch 110 by a fraudulent entity, without gaining physical access to the microsensor patch 110.

[0090] The operation modes of the system 100 enabled by the microsensor patch, the base station 5, the mobile computing device 150, and the processing subsystem 160 are further detailed in FIG. 19. In relation to pairing with the microsensor patch 110 in the first operation mode 5a, the mobile computing device 150 functions to provide one or more of: data relay, data visualization, data storage, notification, and action functions (e.g., as described in relation to the software module 163 described above). In communicating information between the mobile computing device 150 and a cloud module of the processing subsystem 160, the mobile computing device 150 can be configured to transmit raw data in Javascript Object Notation (JSON) format (or any other suitable format) to be processed in the cloud, and

analyte data, notifications, and alerts (e.g., as derived from an analysis) can be transmitted back to the mobile computing device 150 in JSON format (or any other suitable format). The cloud module of the processing subsystem 160 can thus serve to enable authentication of the user (e.g., in association with a user account of a native application) and/or data, data storage, data processing, notification, and prediction functions, as described in relation to the processing subsystem 160 described above. Thus, the system 100 is configured for fault tolerance, wherein the microsensor patch 110 stores data when faulty operation of the mobile computing device 150 occurs, and failure of the processing subsystem 100 results in data storage at the mobile computing device. The system 100 can, however, be configured in any other suitable manner.

[0091] As shown in FIG. 18B, the base station 5 and the patch applicator 180 can be configured to couple together, thus facilitating portability of the base station 5 and patch applicator 180. However, the base station 5, patch applicator 180, and microsensor 110 can alternatively be configured to couple or not couple together in any other suitable manner.

1.5 System—Calibration

[0092] The microsensor patch 110 is preferably calibrated to prevent signal degradation and to mitigate the effects of transient effects experienced during analyte sensing. The primary sensing mechanism is potentiometric for small analytes (e.g., potassium, sodium, calcium), and amperometric for large molecules (e.g., glucose, lactic, creatinine). In a first variation, the microsensor patch 110 passively detects analytes by detecting an impedance and/or capacitance change, as well as a voltage change when an analyte or analyte concentration contacts the microsensor 116. Calibration can occur by normalizing sensing measurements relative to a grounded portion of the microsensor 116, such as a reference electrode.

[0093] In a second variation, the microsensor patch 110 can implement active impedance calibration, wherein a drive voltage is implemented by the electronics subsystem 111 of the microsensor patch 110, and voltage and impedance and/or capacitance changes are detected. The drive voltage is preferably applied in a sinusoidal pattern, but can alternatively be applied in any appropriate pattern. In the second variation, sensed analytes or analyte concentrations are characterized by changes in impedance, and noise is characteristically distinguished from analyte detection by monitoring changes in voltage unaccompanied by changes in impedance or capacitance. The second variation thus employs a conductometric measurement to calibrate the microsensor patch 110. Impedance measurements can also be used to address shift in a reference electrode (e.g., in the first variation described above).

[0094] In a third variation, the microsensor patch 110 can employ injection of a volume of a calibration solution with a known concentration of at least one analyte, in order to calibrate the microsensor patch 110. In an example of the third variation, the calibration solution can have a known concentration of at least one analyte, such that changes (e.g., changes in electrical parameters) detected by the microsensor patch 110 in response to the calibration solution can be used to normalize measurements resulting from sensed analytes or analyte concentrations occurring after injection of the volume of calibration solution. In the third variation, the calibration solution can be injected automatically and

periodically over the lifetime usage of the transdermal patch; however, the calibration solution can alternatively be injected when prompted by a user or other entity.

[0095] In a fourth variation, the microsensor patch 110 can include a membrane comprising a known concentration and/or release profile of at least one analyte, in order to calibrate the microsensor patch 110. In an example of the fourth variation, the membrane can have a known concentration and release profile of at least one analyte, such that changes (e.g., changes in electrical parameters) detected by the microsensor patch 110 in response to the membrane can be used to normalize measurements resulting from sensed analytes or analyte concentrations. In the fourth variation, the membrane can be a degradable membrane, such that degradation of the membrane over time releases analytes from the membrane. Alternatively, the membrane can be manufactured with specific porosity, contributing to a certain analyte release profile.

[0096] In a fifth variation, the microsensor patch 110 can include a coating or a cap comprising a soluble species (e.g., analyte/ion) with a well-known solubility, in order to calibrate the microsensor patch 110. In an example of the fifth variation, the soluble species maintains a known concentration of the species within the vicinity of a filament that can be used to normalize and/or calibrate a signal. Examples of soluble species include low solubility, biocompatible calcium salts, such as calcium carbonate, calcium phosphate, and dicalcium phosphate for calcium sensing. Other suitable soluble species can be used to calibrate other analytes.

[0097] In alternative variations, the microsensor patch 110 can use any other suitable calibration method. For instance, the transdermal patch can be pre-staged, prepped, loaded, or activated to have a set calibration state enabling calibration of the system after application to the user within a desired period of time (e.g., an 85 mg/dl calibration state equilibrated after insertion within a period of 2 hours).

[0098] As a person skilled in the art will recognize from the previous detailed description and from the figures and claims, modifications and changes can be made to the described embodiments, variations, and examples of the system 100 without departing from the scope of the system 100.

2. Method

[0099] As shown in FIG. 20, a method 200 for monitoring body chemistry of a user comprises: receiving a second housing portion into an opening of a first housing portion S210, the first housing portion supporting a microsensor including a first working electrode, a second working electrode, a reference electrode, and a counter electrode, and the second housing portion supporting an electronics subsystem configured to receive a signal stream from the microsensor; after interfacing with the second housing portion, accelerating the second housing portion toward skin of the user S220, thereby delivering sensing regions of the microsensor into interstitial fluid of the user; generating an impedance signal, from two of the first working electrode, the second working electrode, the reference electrode, and the counter electrode, in response to applying a voltage, near a shifted potential different than a reference potential of the reference electrode S230, wherein the shifted potential is associated with a signal conditioning module of the electronics subsystem; at a processing system in communication with the electronics subsystem, receiving the signal stream and the

impedance signal S240; at the processing system, generating an analysis indicative of an analyte parameter of the user and derived from the signal stream and the impedance signal S250; and transmitting information derived from the analysis to an electronic device associated with the user, thereby facilitating monitoring of body chemistry of the user S260.

[0100] The method 200 functions to provide continuous monitoring of a user's body chemistry through reception and processing of signals associated with one or more analytes present in the body of the user, and to provide an analysis of the user's body chemistry to the user and/or an entity (e.g., health care professional, caretaker, relative, friend, acquaintance, etc.) associated with the user. Alternatively, the method 200 can function to detect a user's body chemistry upon the user's request or sporadically, and/or can provide an analysis of the user's body chemistry only to the user. The method is preferably implemented, at least in part, using an embodiment, variation, or example of elements of the system 100 described in Section 1 above; however, the method 200 can additionally or alternatively be implemented using any other suitable system.

[0101] Variations of the system 100 and method 200 include any combination or permutation of the described components and processes. Furthermore, various processes of the preferred method can be embodied and/or implemented at least in part as a machine configured to receive a computer-readable medium storing computer-readable instructions and/or in the cloud. The instructions are preferably executed by computer-executable components preferably integrated with a system and one or more portions of a control module and/or a processor. The computer-readable medium can be stored on any suitable computer readable media such as RAMs, ROMs, flash memory, EEPROMs, optical devices (CD or DVD), hard drives, floppy drives, or any suitable device. The computer-executable component is preferably a general or application specific processor, but any suitable dedicated hardware device or hardware/firmware combination device can additionally or alternatively execute the instructions.

[0102] The FIGURES illustrate the architecture, functionality and operation of possible implementations of systems, methods and computer program products according to preferred embodiments, example configurations, and variations thereof. In this regard, each block in the flowchart or block diagrams may represent a module, segment, step, or portion of code, which comprises one or more executable instructions for implementing the specified logical function(s). It should also be noted that, in some alternative implementations, the functions noted in the block can occur out of the order noted in the FIGURES. For example, two blocks shown in succession may, in fact, be executed substantially concurrently, or the blocks may sometimes be executed in the reverse order, depending upon the functionality involved. It will also be noted that each block of the block diagrams and/or flowchart illustration, and combinations of blocks in the block diagrams and/or flowchart illustration, can be implemented by special purpose hardware-based systems that perform the specified functions or acts, or combinations of special purpose hardware and computer instructions.

[0103] As a person skilled in the art will recognize from the previous detailed description and from the figures and claims, modifications and changes can be made to the

preferred embodiments of the invention without departing from the scope of this invention defined in the following claims.

We claim:

1. A system for monitoring body chemistry of a user, the system comprising:

a first housing portion supporting a microsensor comprising a working electrode, a reference electrode, and a counter electrode defined on a substrate and collectively operable to sense an analyte within interstitial fluid of the user during use, the first housing portion comprising:

an opening into an electrical interface with the microsensor, and

an adhesive region, surrounding the microsensor at a second surface opposing the electrical interface, the adhesive region coupleable to skin of the user,

a second housing portion insertable into the opening of the first housing portion in a first configuration, the second housing portion supporting:

an electronics subsystem comprising a signal conditioning portion that receives and processes a signal stream from the microsensor upon sensing of the analyte in a sensing mode, the signal conditioning portion configured with an operating potential at a shifted potential different than a reference potential of the reference electrode, wherein, during operation, the electronics subsystem repeatedly transitions between the sensing mode and an impedance detection mode, wherein in the impedance detection mode, the electronics subsystem:

applies a voltage near the shifted potential to the working electrode, and

measures an impedance signal between the working electrode and the reference electrode; and

an applicator operable to accelerate and expel the second housing portion and the first housing portion from the applicator and onto the user, with the adhesive region and a filament array of a microsensor oriented toward skin of the user, thereby coupling the first and the second housing portions to the user and causing the microsensor to penetrate skin of the user prior to coupling of the adhesive region to the user.

2. The system of claim 1, wherein during the sensing mode, the electronics subsystem continuously detects a voltage parameter of the counter electrode and, in cooperation with a processing system:

generates a comparison between the voltage parameter and a voltage threshold condition, and

applies the applied voltage in the impedance detection mode based upon the comparison.

3. The system of claim 1, further comprising a processing subsystem in communication with the electronics subsystem and operable in: a first mode that generates an analysis indicative of an analyte parameter of the user and derived from the signal stream and the impedance signal, and a second mode that render information derived from the analysis at an electronic device associated with the user, thereby facilitating monitoring of body chemistry of the user.

4. The system of claim 1, wherein, in the impedance detection mode, the electronics subsystem applies the voltage having a characteristic value centered about the shifted

potential and a sinusoidal waveform, upon detection of a voltage condition at the counter electrode.

5. The system of claim 1, further comprising a processing system in communication with the electronics subsystem and an electronic device of the user, wherein, in relation to transitioning between the sensing mode and the impedance detection mode, the processing subsystem generates a notification at the electronic device of the user in response to detection of unsuitable impedance derived from a comparison between the impedance signal and an impedance threshold condition.

6. The system of claim 1, wherein in relation to transitioning between the sensing mode and the impedance detection mode, an actuator coupled to the electronics subsystem automatically provides a vibrational force that biases the microsensor into communication with interstitial fluid of the user, in response to detection of unsuitable impedance derived from comparison between the impedance signal and an impedance threshold condition post an initial application of the microsensor into the user.

7. The system of claim 1, further comprising a reused mode wherein the first housing portion is disposed and uncoupled from the second housing portion, and wherein the second housing portion is coupled to a second instance of the first housing portion.

8. A system for monitoring body chemistry of a user, the system comprising:

a first housing portion supporting a microsensor comprising a working electrode, a reference electrode, and a counter electrode defined on a substrate and collectively operable to sense an analyte within interstitial fluid of the user during use, the first housing portion comprising:

an opening into an electrical interface with the microsensor, and

an adhesive region, surrounding the microsensor at a second surface opposing the electrical interface, the adhesive region coupleable to skin of the user; and

a second housing portion insertable into the opening of the first housing portion in a first configuration, the second housing portion supporting:

an electronics subsystem comprising a signal conditioning portion that receives and processes a signal stream from the microsensor upon sensing of the analyte in a sensing mode, the signal conditioning portion configured with an operating potential at a shifted potential different than a reference potential of the reference electrode, wherein, during operation, the electronics subsystem repeatedly transitions between the sensing mode and an impedance detection mode, wherein in the impedance detection mode, the electronics subsystem:

applies a voltage near the shifted potential to an electrode subset comprising at least one the working electrode and the counter electrode, and

measures an impedance signal between the electrode subset and the reference electrode.

9. The system of claim 8, wherein during the sensing mode, the electronics subsystem continuously detects a voltage parameter of the counter electrode and, in cooperation with a processing system:

generates a comparison between the voltage parameter and a voltage threshold condition, and

applies the applied voltage in the impedance detection mode based upon the comparison.

10. The system of claim 8, wherein the microsensor comprises a second working electrode defined on the substrate.

11. The system of claim 8, further comprising a reused mode wherein the first housing portion is disposed and uncoupled from the second housing portion, and wherein the second housing portion is coupled to a second instance of the first housing portion.

12. The system of claim 8, wherein the microsensor comprises an array of microfilaments, each filament in the array comprising i) a substrate core extending from the substrate and comprising a columnar protrusion having a base end and a distal portion operable to provide access to interstitial fluid of the user during use; ii) a conductive layer, isolated to the distal portion of the substrate core and away from the base end and operable to transmit electronic signals generated upon detection of the analyte; iii) an insulating layer surrounding the substrate core and exposing a portion of the conductive layer at the distal portion; and iv) a sensing layer coupled to the conductive layer and operable to sense the analyte.

13. The system of claim 12, wherein the microsensor comprises a selective layer, having a distribution of molecules that interact with the analyte, coupled to the sensing layer.

14. The system of claim 8, wherein at least one of the microsensor and the electronics subsystem comprises a temperature sensor operable to measure body temperature of the user during use of the system.

15. The system of claim 8, further comprising a processing subsystem in communication with the electronics subsystem and operable in: a first mode that generates an analysis indicative of an analyte parameter of the user and derived from the signal stream and the impedance signal, and a second mode that render information derived from the analysis at an electronic device associated with the user, thereby facilitating monitoring of body chemistry of the user.

16. The system of claim 15, further comprising: at the processing subsystem, rendering a present state of the analyte parameter, indicating a future state toward which the analyte parameter is predicted to trend, and a percent of time value within a time duration at which values of the analyte parameter are within a target range, wherein the values of the analyte parameter comprise future state values of the analyte parameter.

17. The system of claim 8, wherein the electrical interface of the first housing portion comprises a set of concentric ring contacts configured to interface electronics of the second housing portion with filaments of the microsensor, in any rotated configuration of the second housing portion within the opening of the first housing portion.

18. The system of claim 8, further comprising a charging and data transfer mode, wherein transitioning to the charging and data transfer mode is triggered upon positioning the second housing portion, with the electronics subsystem into proximity with a base station, wherein, in the charging and data transfer mode, a battery of the electronics subsystem is charged by the base station and data is transferred between the electronics subsystem and a mobile computing device associated with the user.

19. The system of claim **8**, further comprising an applicator operable to accelerate and expel the second housing portion and the first housing portion from the applicator and onto the user, with the adhesive region and a filament array of a microsensor oriented toward skin of the user, thereby coupling the first and the second housing portions to the user and causing the microsensor to penetrate skin of the user prior to coupling of the adhesive region to the user.

20. The system of claim **19**, wherein accelerating the second housing portion and the first housing portion comprises, in response to a user interacting with a trigger of an applicator, transitioning a plunger of the applicator from a resting state to a loaded configuration with the plunger contacting the second housing portion, and releasing the plunger to accelerate the second housing portion toward skin of the user along a first axis perpendicular to the skin of the user, wherein the applicator and the plunger are arranged exterior the first and the second housing, and wherein the applicator surrounds the first and the second housing portion.

* * * * *

专利名称(译)	用于监测身体化学的系统		
公开(公告)号	US20180140235A1	公开(公告)日	2018-05-24
申请号	US15/876678	申请日	2018-01-22
[标]申请(专利权)人(译)	萨诺智能公司		
申请(专利权)人(译)	佐野智力, INC.		
当前申请(专利权)人(译)	佐野智力, INC.		
[标]发明人	PUSHPALA ASHWIN CHAPMAN MATTHEW SZMODIS ALAN GHOSH ABHIJIT		
发明人	PUSHPALA, ASHWIN CHAPMAN, MATTHEW SZMODIS, ALAN GHOSH, ABHIJIT		
IPC分类号	A61B5/145 A61B5/00 A61B5/01 A61B17/34 A61B5/1486		
CPC分类号	A61B2562/028 A61B2562/046 A61B2562/164 A61B5/14532 A61B17/3468 A61B5/7285 A61B5/14514 A61B5/01 A61B5/685 A61B5/6849 A61B5/6833 A61B5/14865 A61B5/0002 A61B5/0022 A61B5/0537 A61B5/0538 A61B5/1451 A61B5/14546 A61B5/688 A61B5/6885 A61B5/7275 A61B5/7278 A61B5/746 A61B2562/0214 G16H40/67		
优先权	62/025174 2014-07-16 US 61/952594 2014-03-13 US 62/012874 2014-06-16 US		
外部链接	Espacenet USPTO		

摘要(译)

1. 一种用于监测使用者的身体化学的系统和方法, 所述系统包括: 壳体, 所述壳体支撑: 微传感器, 所述微传感器包括第一工作电极和第二工作电极, 参考电极和反电极, 并且被配置为访问使用者的组织液, 包括信号调节模块的电子子系统, 所述信号调节模块从所述微传感器接收信号流, 其中所述电子子系统被配置为检测源自所述第一工作电极, 所述第二工作电极, 所述参考电极和所述计数器中的两个的阻抗信号电极; 以及处理子系统, 其包括: 第一模块, 其被配置为生成指示用户的分析物参数并且从信号流和阻抗信号导出的分析; 以及第二模块, 其被配置为将从分析导出的信息传输给用户, 由此便于监测用户的身体化学。

