



US 20180104506A1

(19) **United States**

(12) **Patent Application Publication**
Kurtz et al.

(10) **Pub. No.: US 2018/0104506 A1**
(43) **Pub. Date: Apr. 19, 2018**

(54) **MOBILE PLATFORM FOR
NONPHARMACOLOGIC CONSTRICTION
OF A PUPIL**

A61B 5/00 (2006.01)
A61F 9/00 (2006.01)
H01S 3/00 (2006.01)

(71) Applicants: **Ronald Michael Kurtz**, Irvine, CA
(US); **Gergely T. Zimanyi**, Berkeley,
CA (US)

(52) **U.S. Cl.**
CPC *A61N 5/06* (2013.01); *A61B 3/14*
(2013.01); *A61B 5/0002* (2013.01); *A61N*
2005/065 (2013.01); *H01S 3/0007* (2013.01);
A61N 2005/0635 (2013.01); *A61F 9/00*
(2013.01)

(72) Inventors: **Ronald Michael Kurtz**, Irvine, CA
(US); **Gergely T. Zimanyi**, Berkeley,
CA (US)

(21) Appl. No.: **15/372,390**

(22) Filed: **Dec. 7, 2016**

Related U.S. Application Data

(63) Continuation-in-part of application No. 15/293,269,
filed on Oct. 13, 2016.

Publication Classification

(51) **Int. Cl.**
A61N 5/06 (2006.01)
A61B 3/14 (2006.01)

(57) **ABSTRACT**

An ophthalmic stimulator for temporarily constricting a pupil of art eye comprises a mobile irradiation control system, to generate an irradiation control signal; an irradiation source, coupled to the irradiation control system, to generate an irradiation; and an irradiation delivery system, coupled to the mobile irradiation control system, to receive the irradiation from the irradiation source, and to deliver a patterned irradiation to an iris of the eye; wherein the mobile irradiation control system controls at least one of the irradiation source and the irradiation delivery system with the irradiation control signal so that the patterned irradiation causes a temporary constriction of the pupil of the eye, without causing a permanent constriction of the pupil.

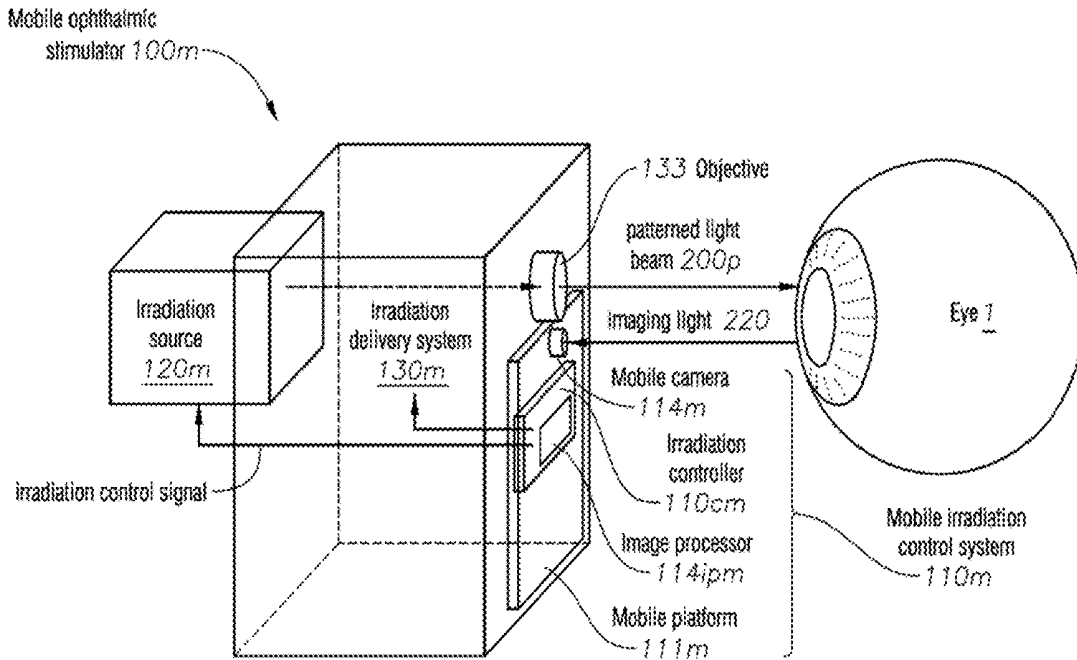

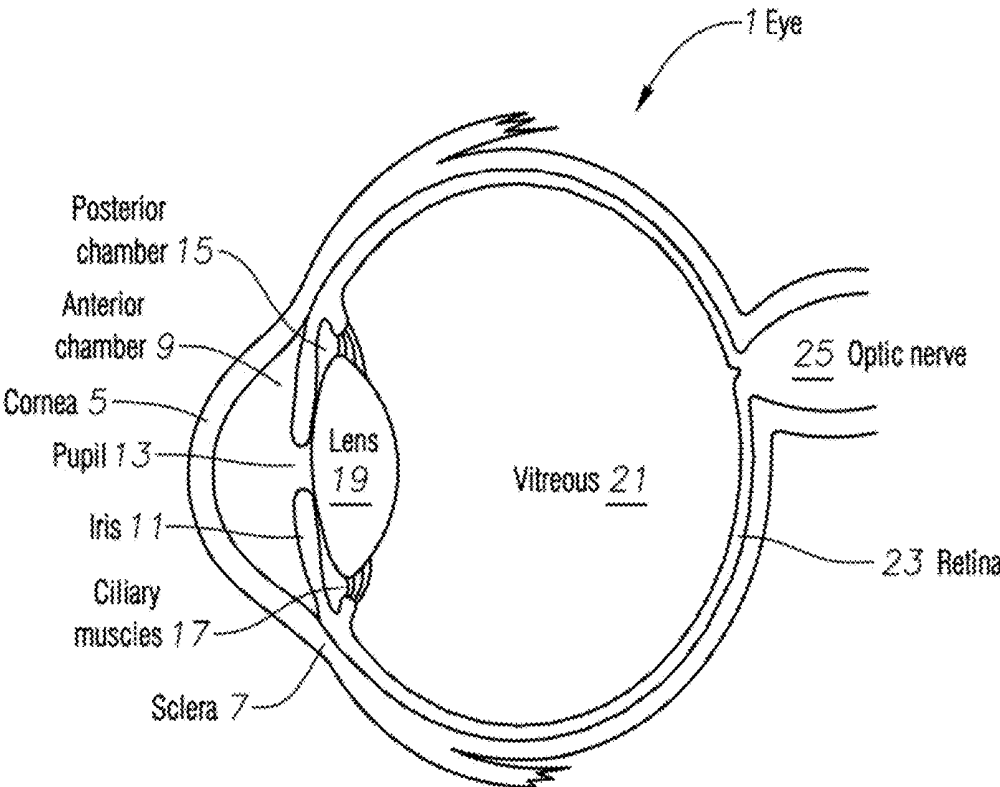

FIG. 1

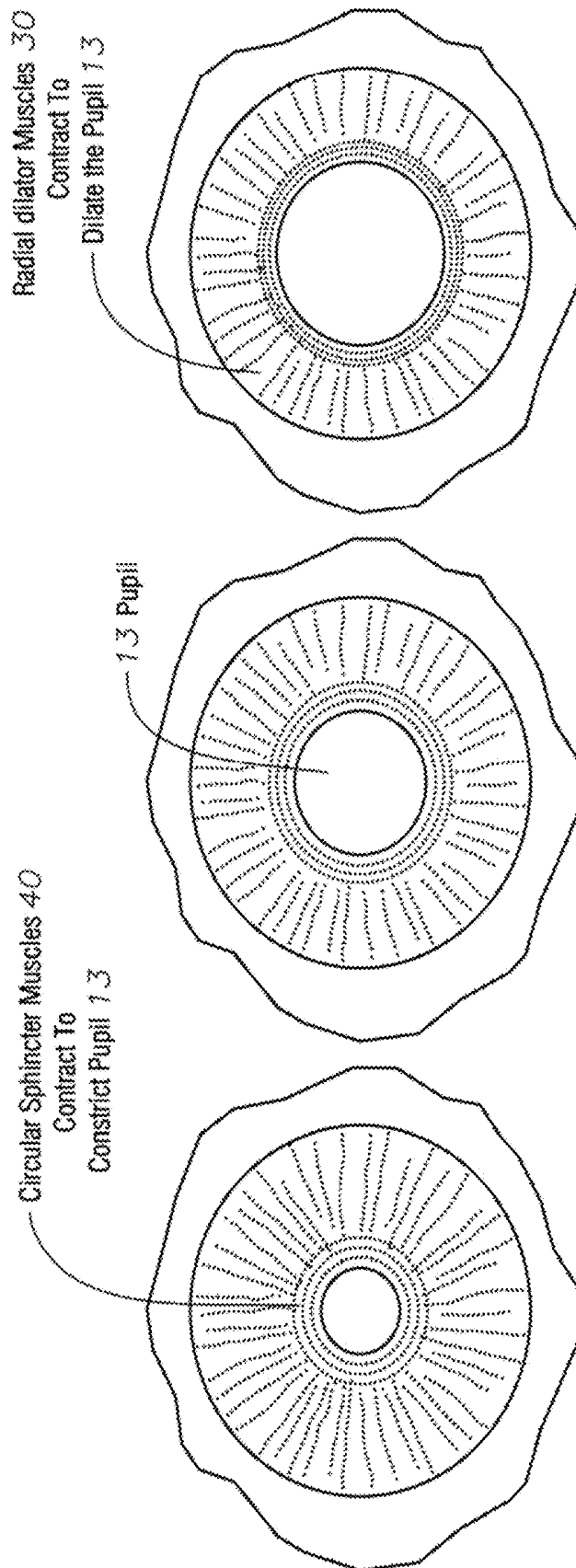

FIG. 2A

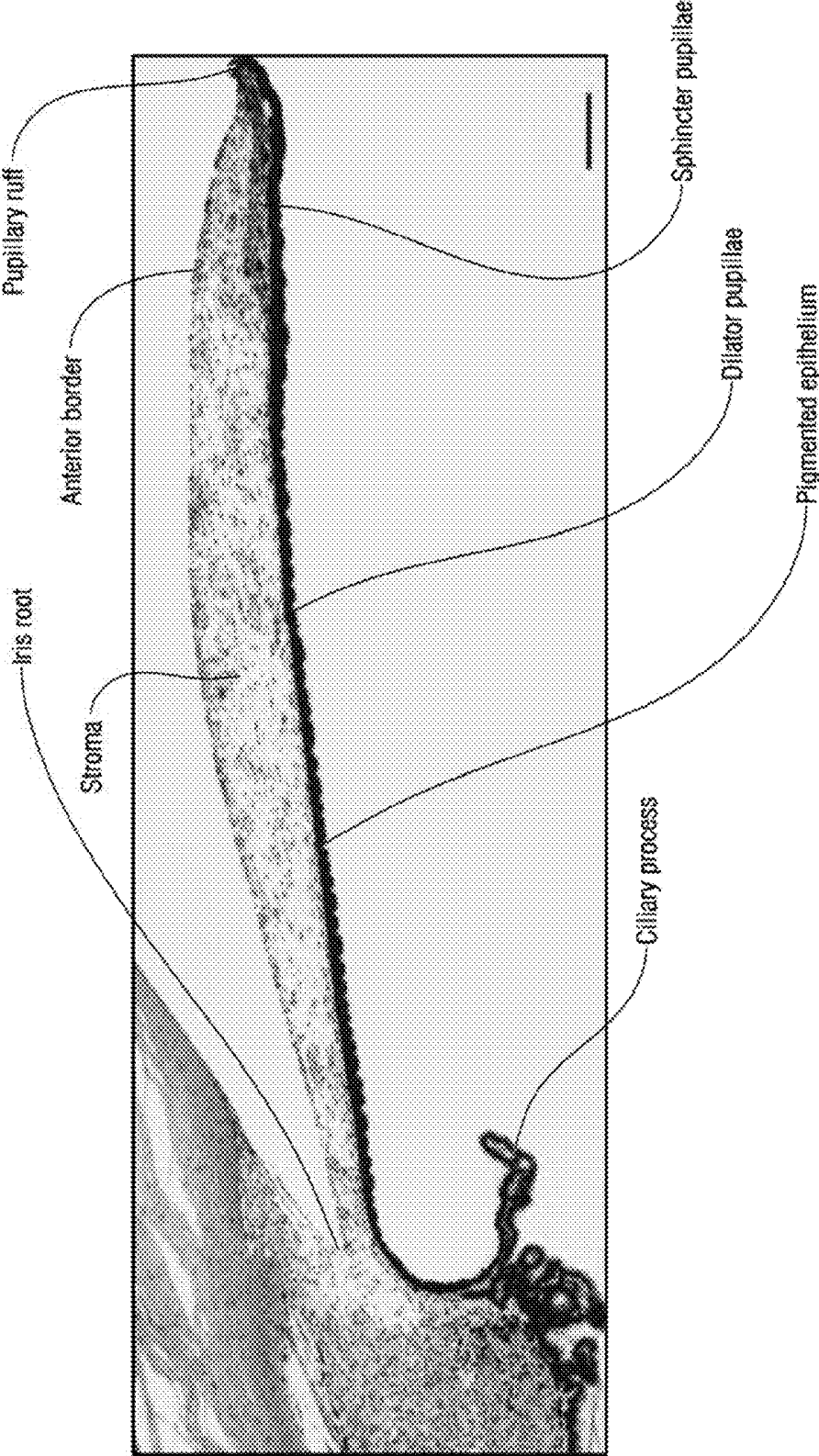

FIG. 2B

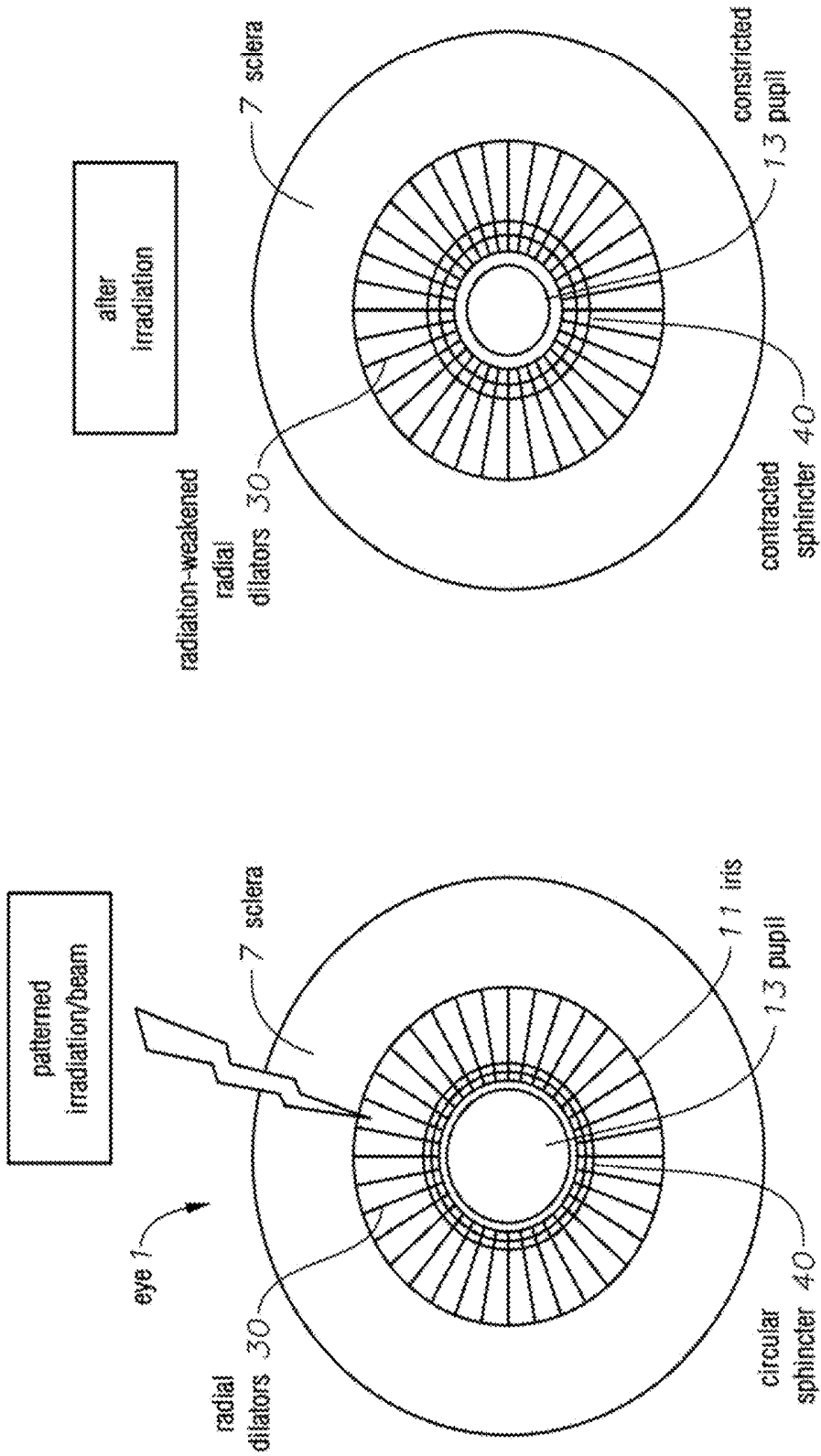

FIG. 3B

FIG. 3A

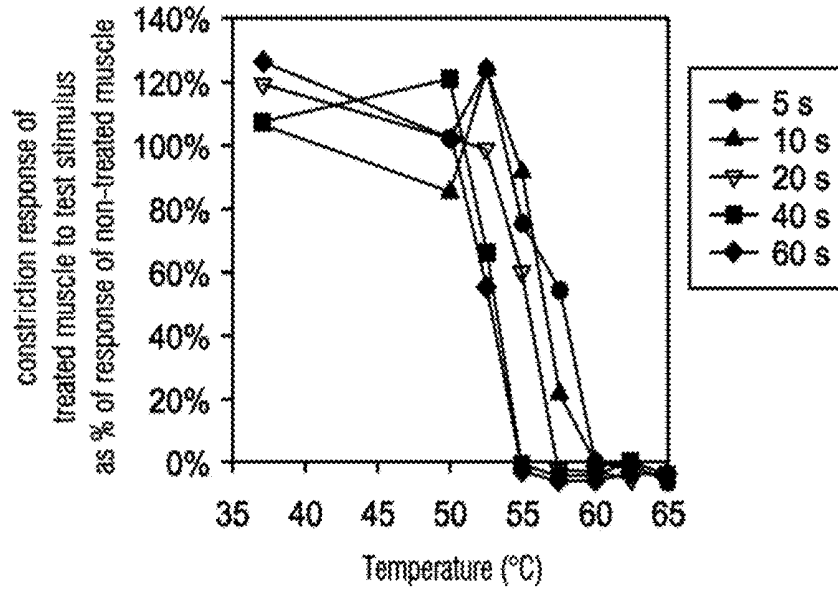

FIG. 4A

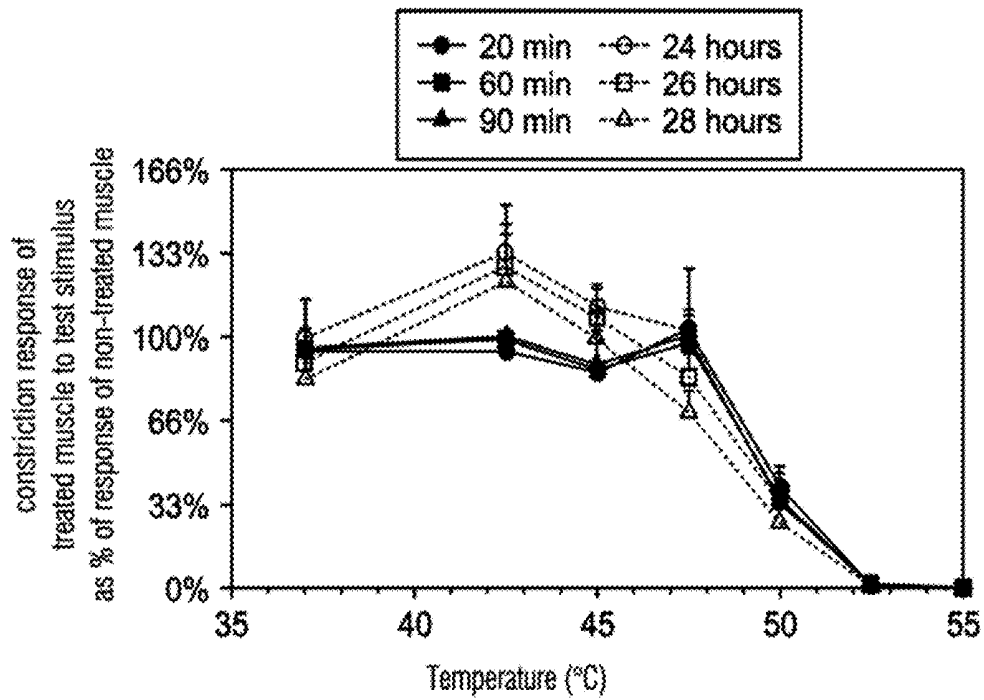

FIG. 4B

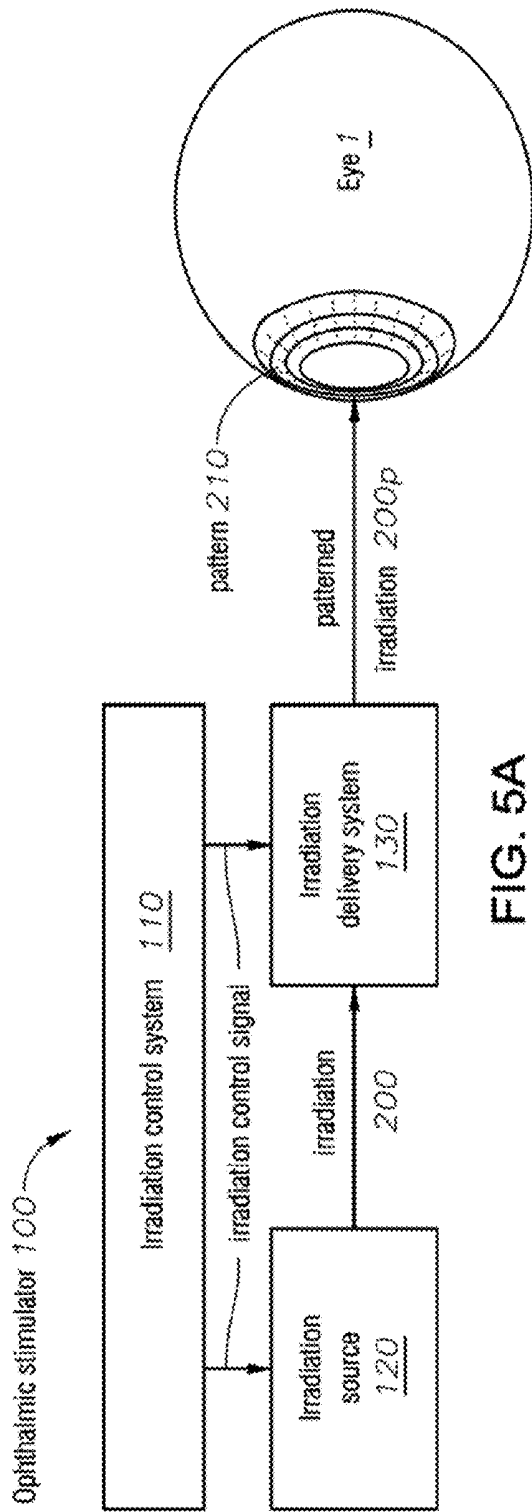

FIG. 5A

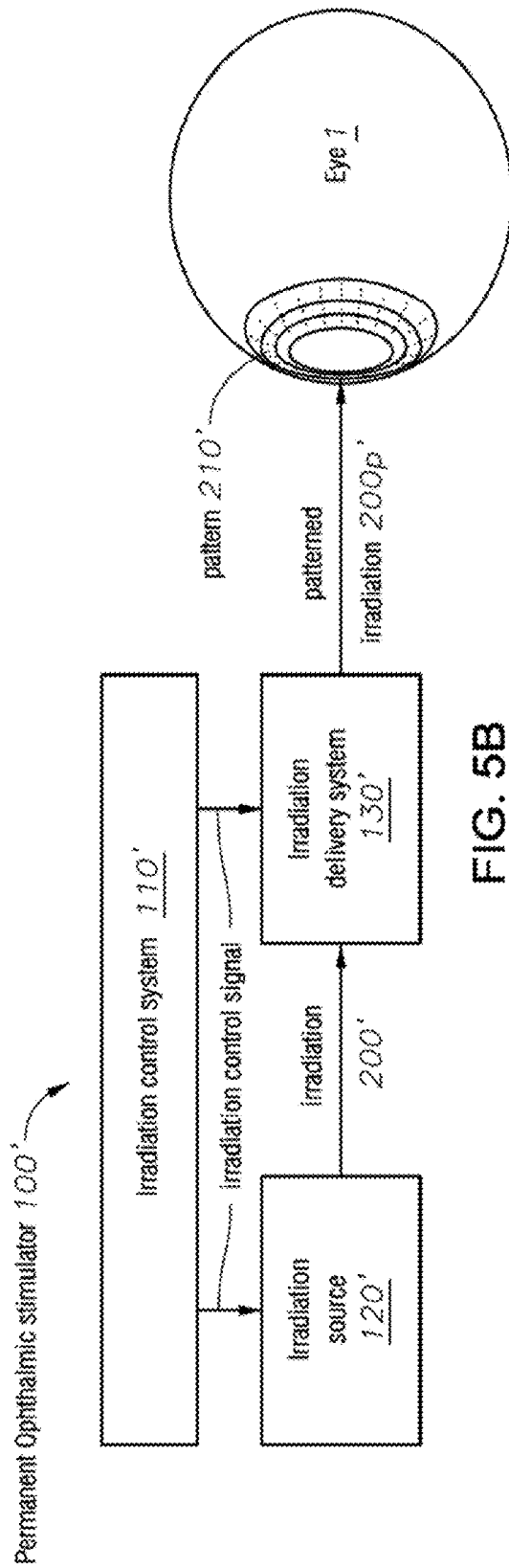

FIG. 5B

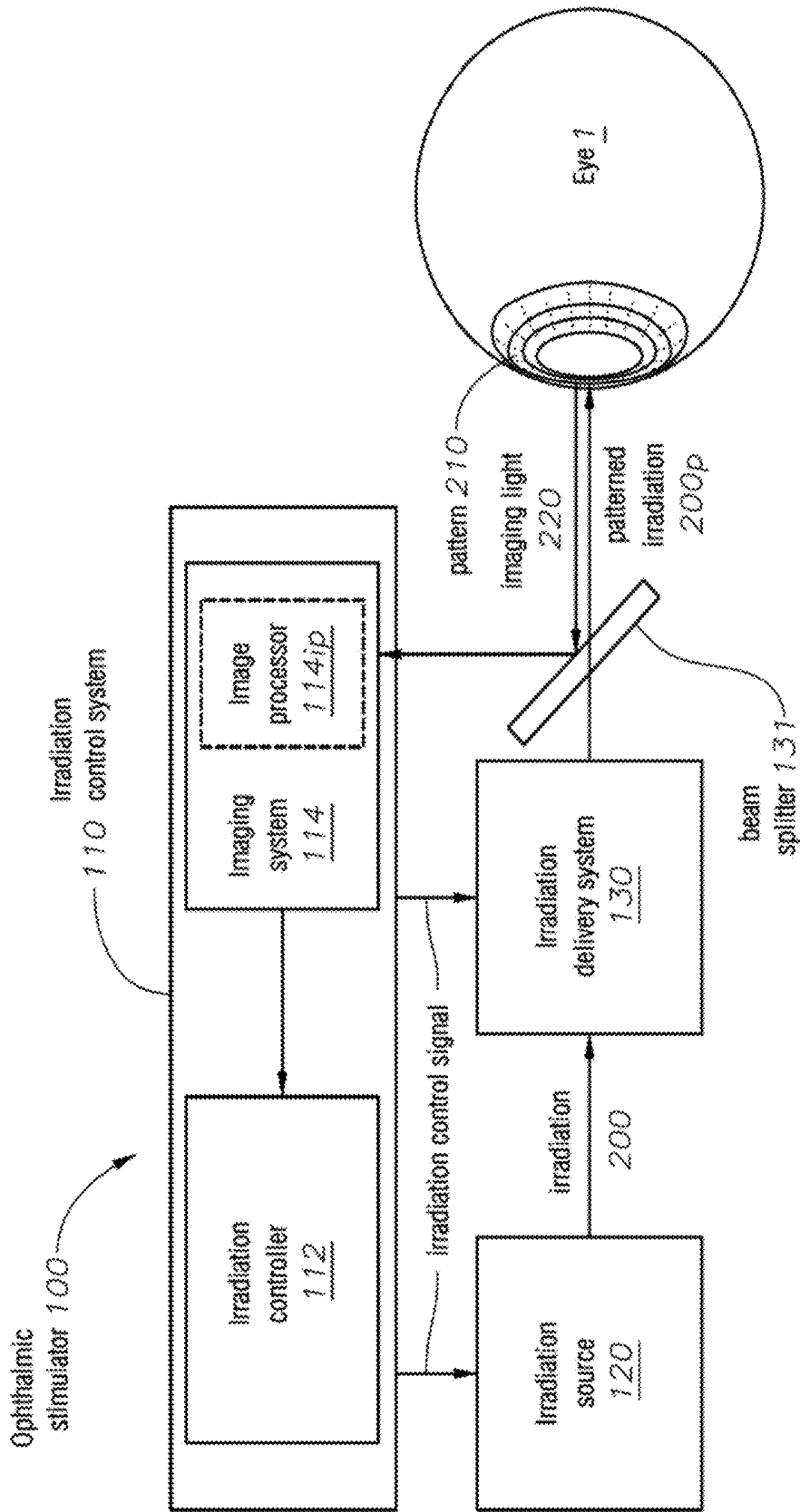

FIG. 6A

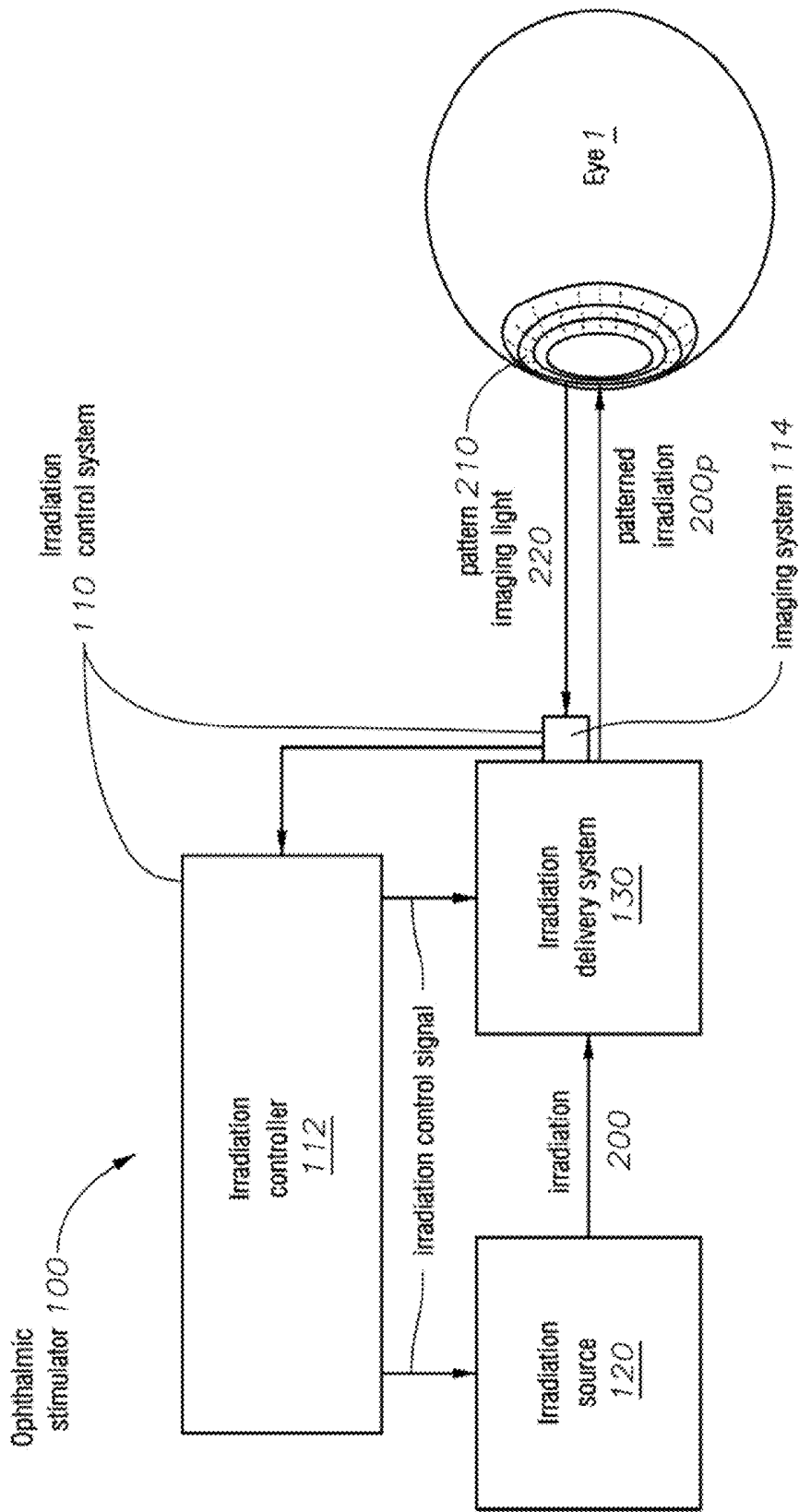

FIG. 6B

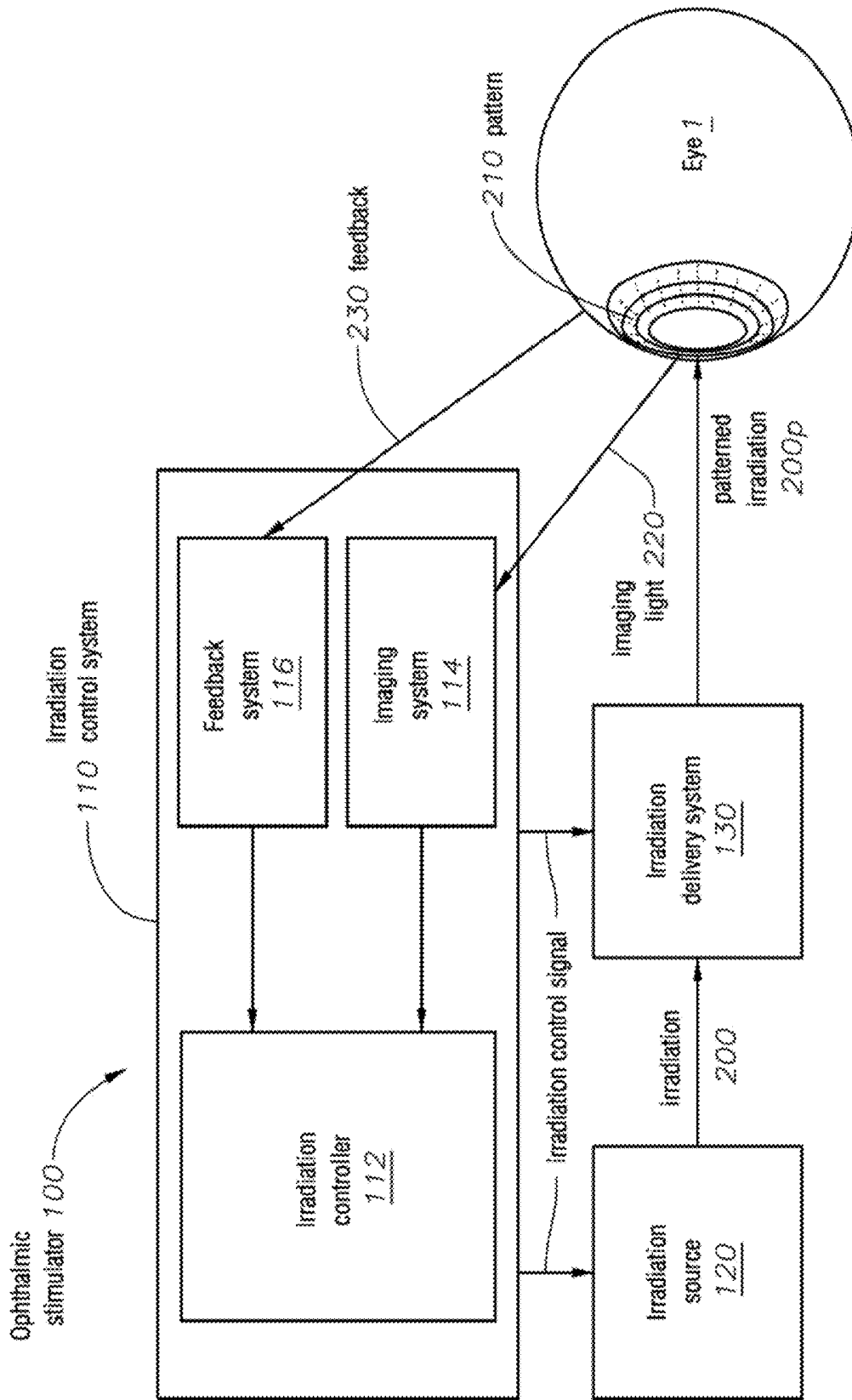

FIG. 6C

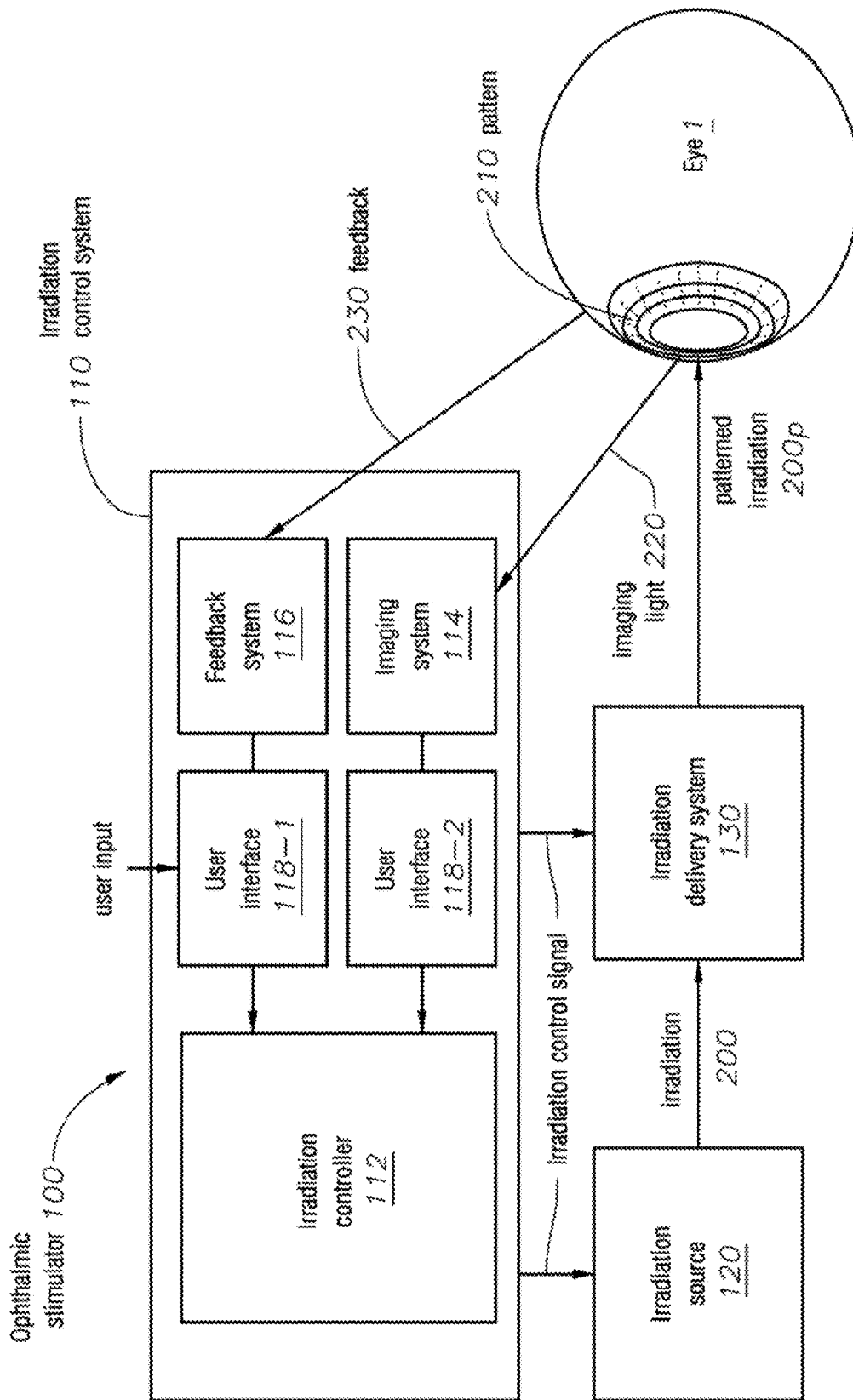

FIG. 6D

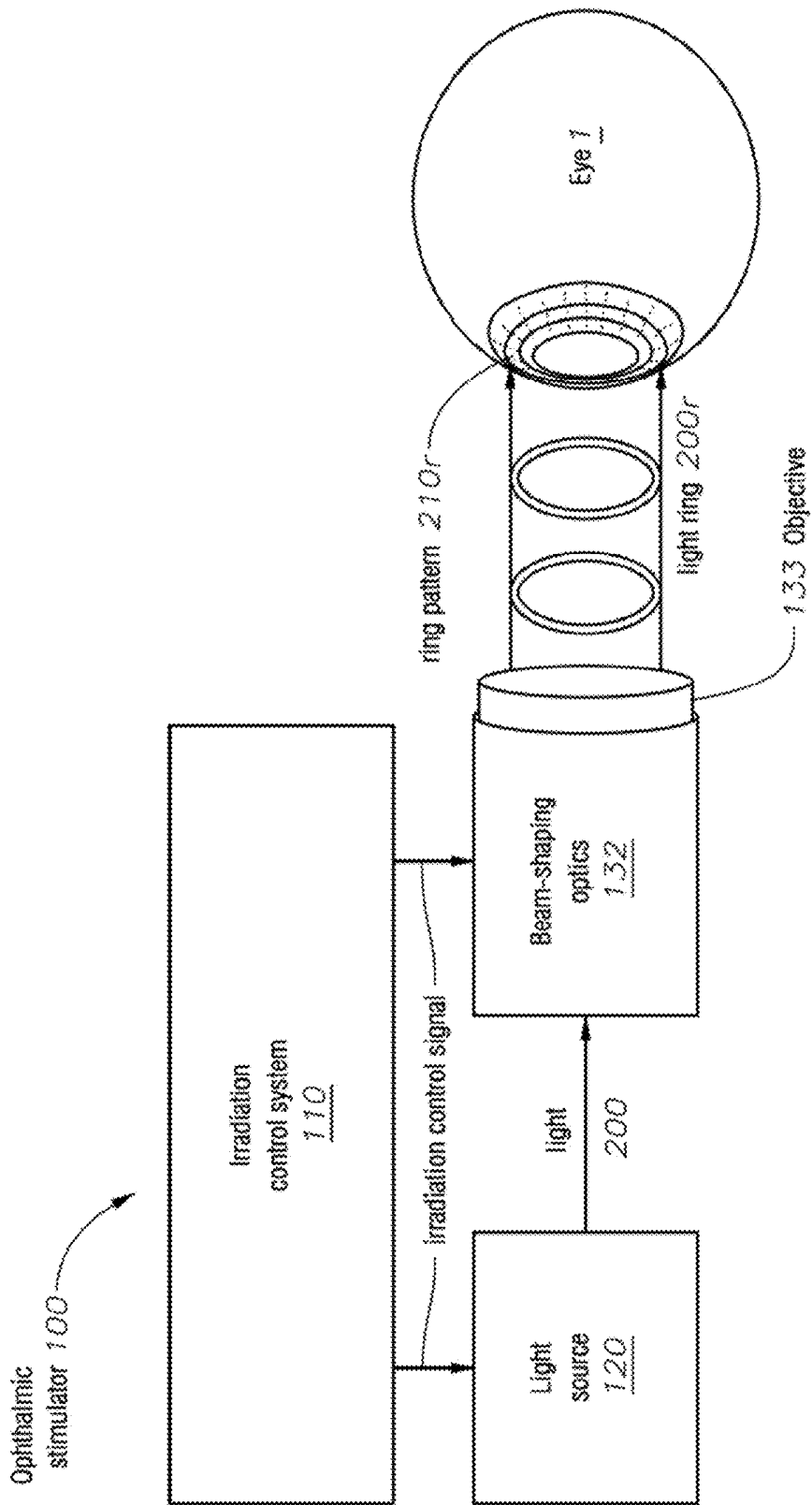

FIG. 7A

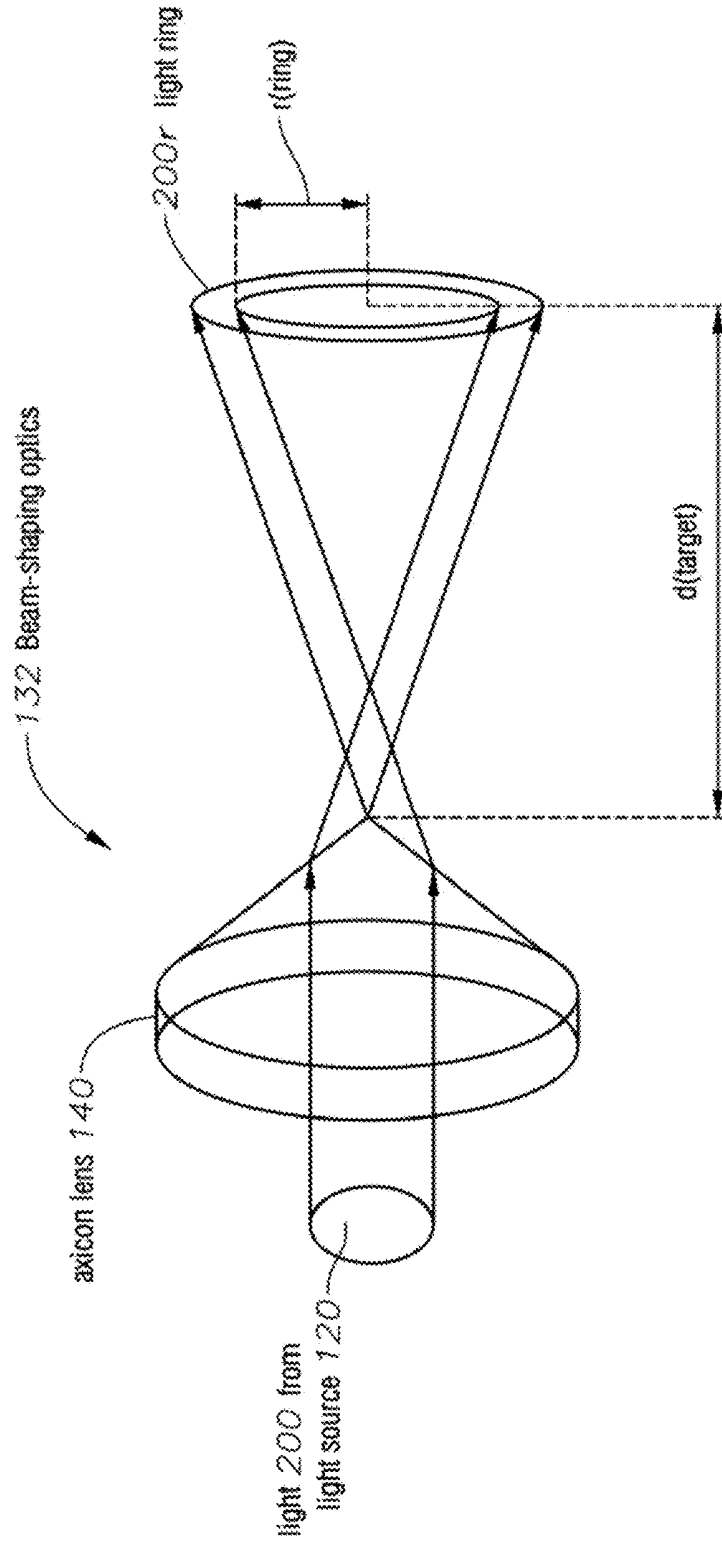

FIG. 7B

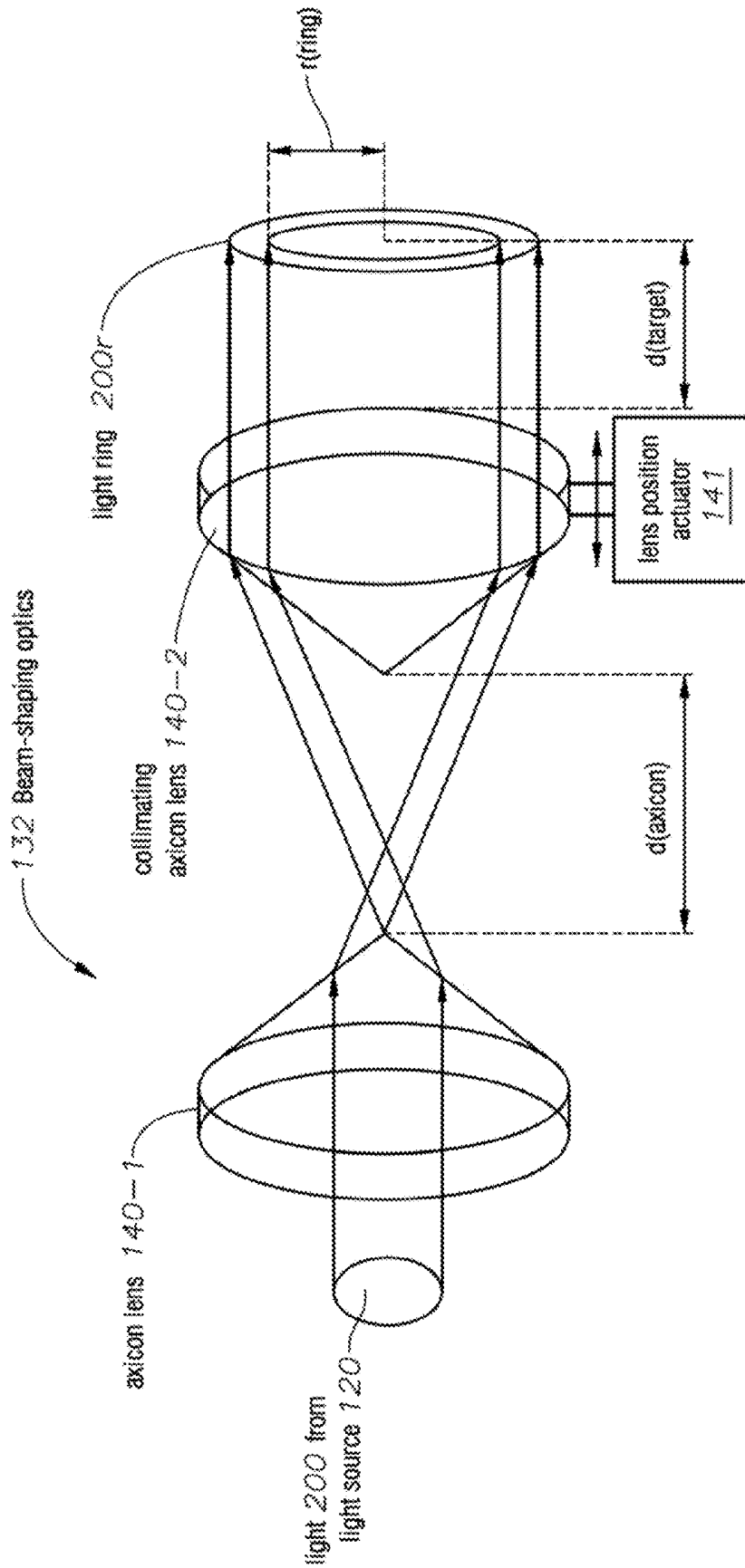

FIG. 7C

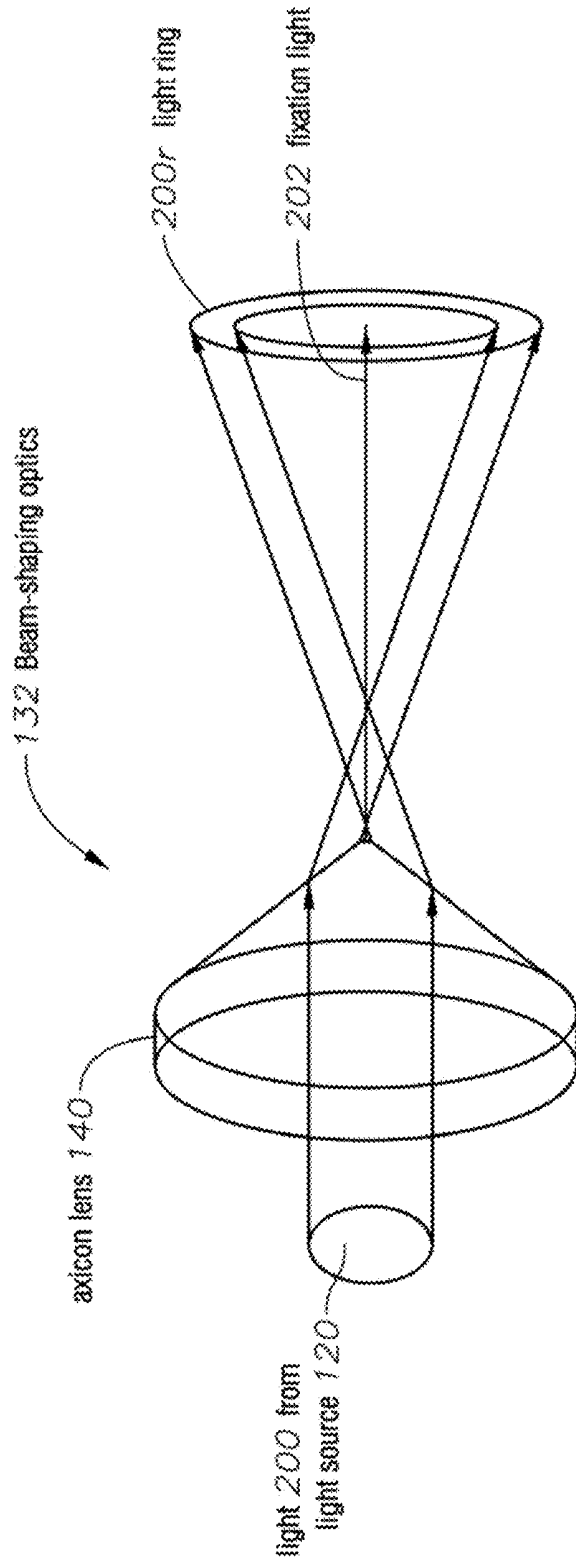

FIG. 7D

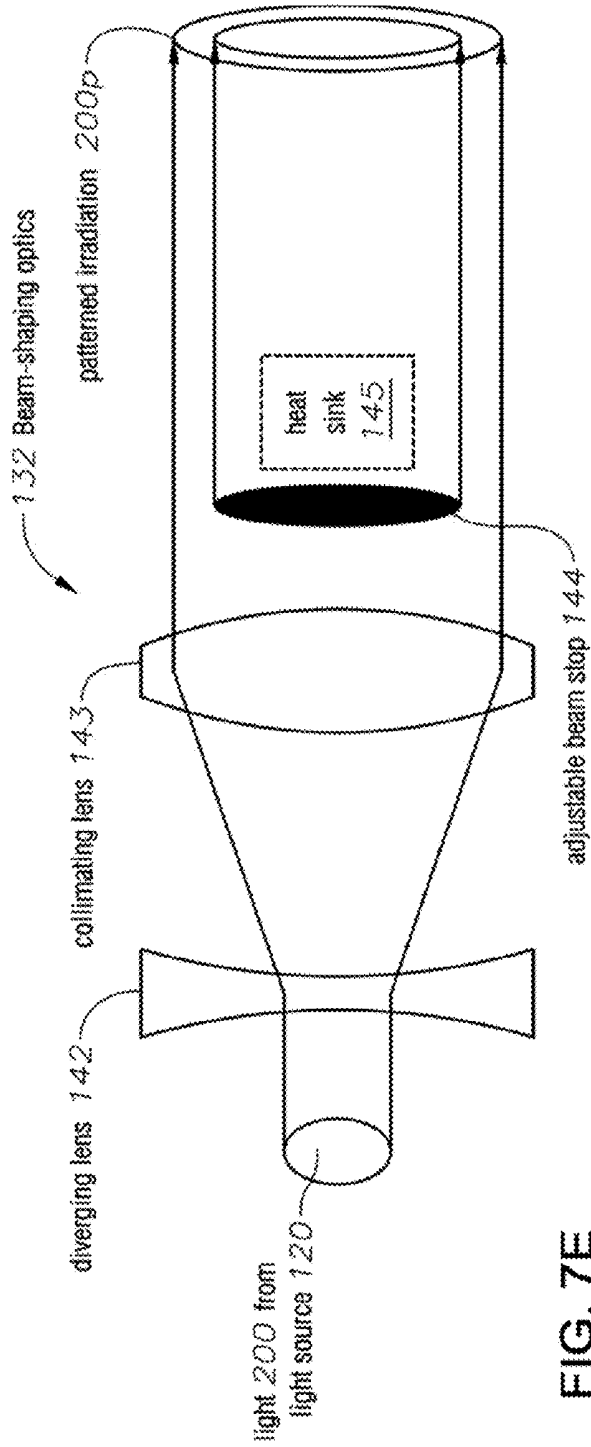

FIG. 7E

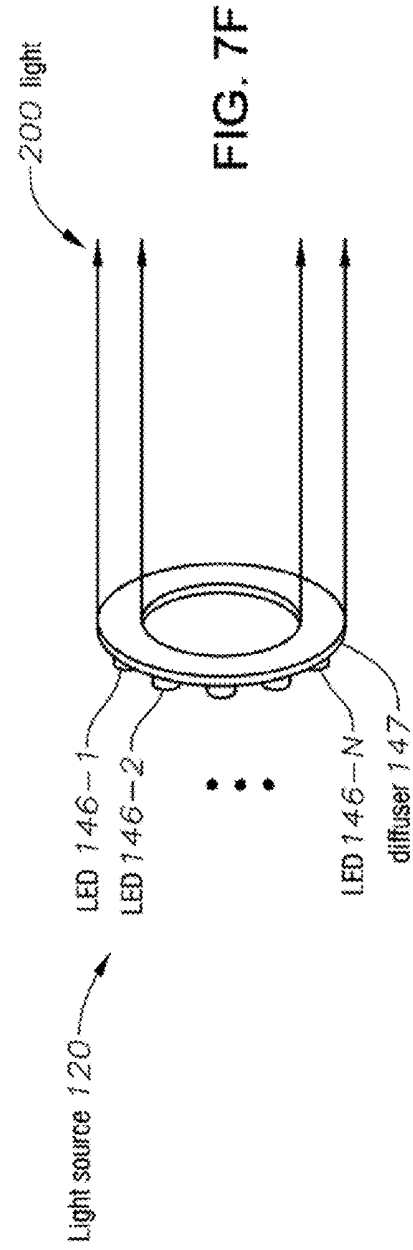

FIG. 7F

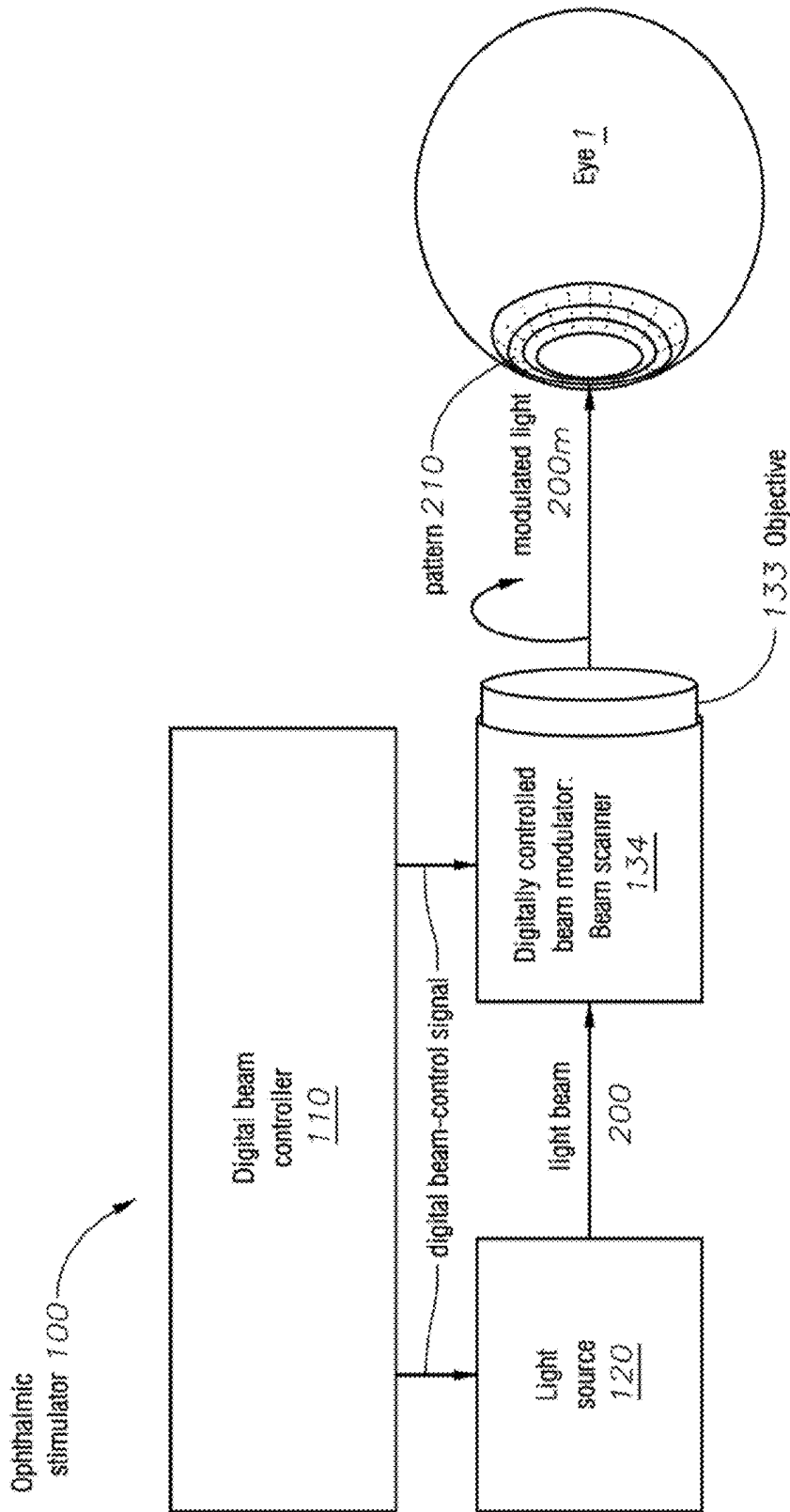

FIG. 8A

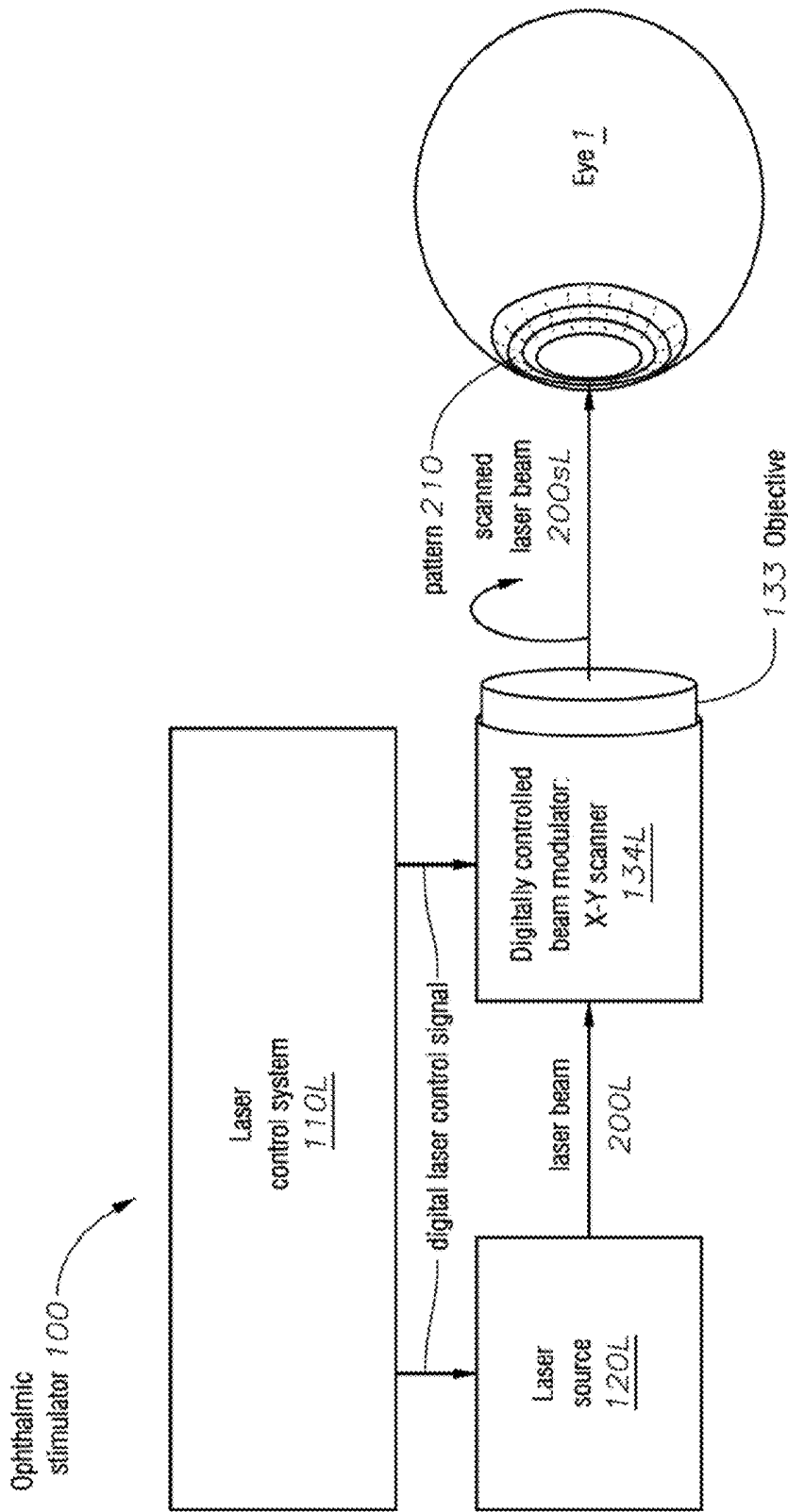

FIG. 8B

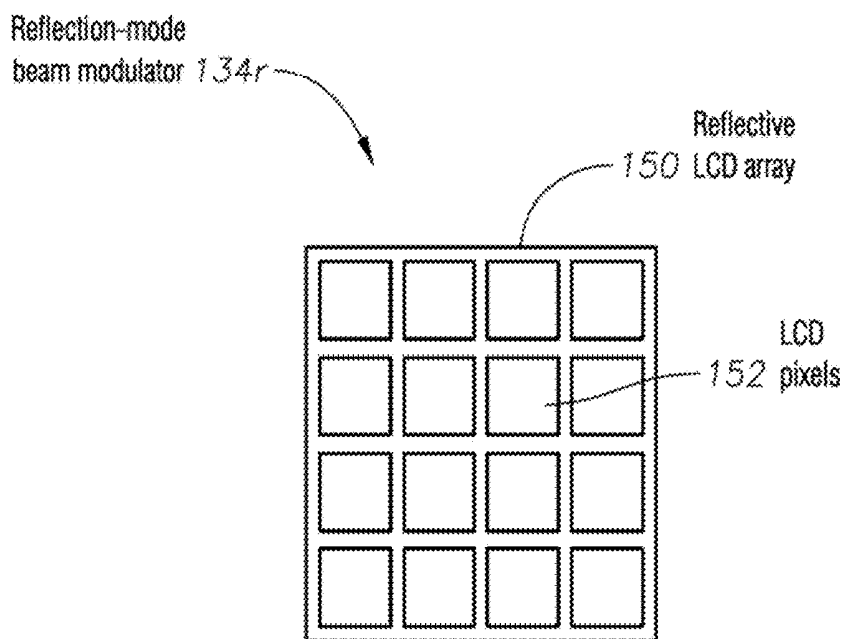

FIG. 9A

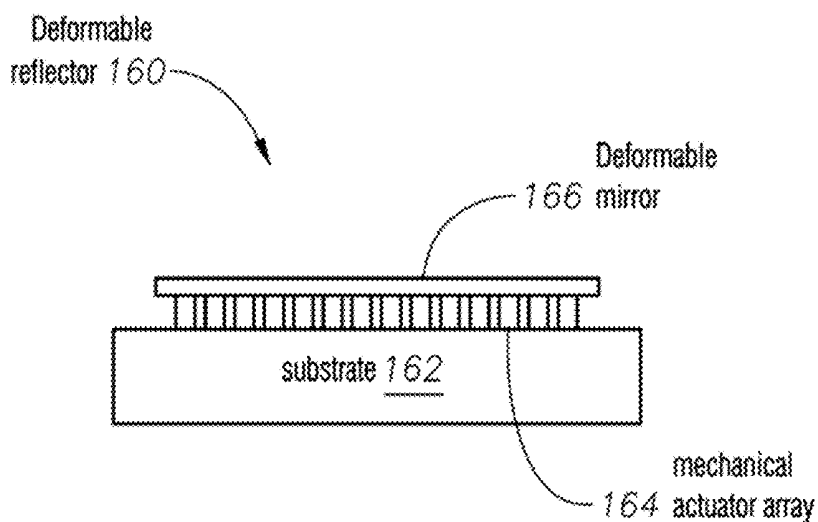

FIG. 9B

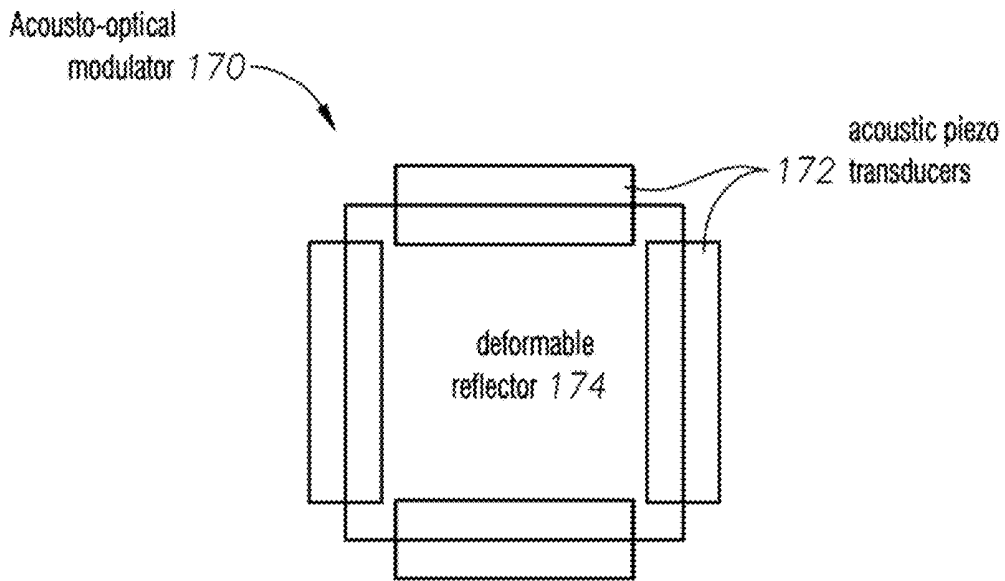

FIG. 9C

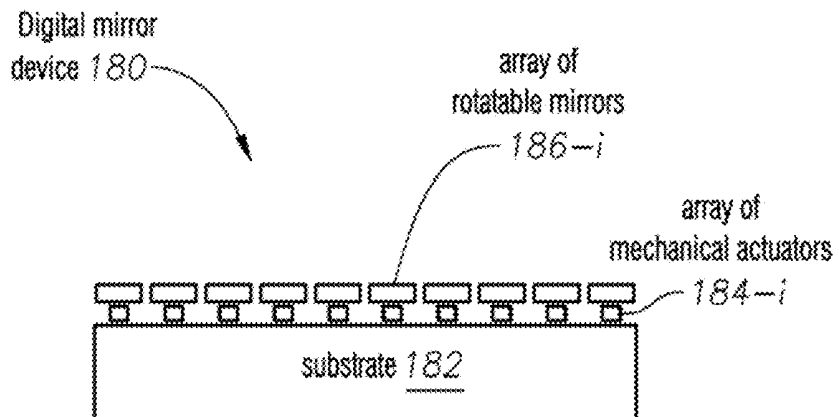

FIG. 9D

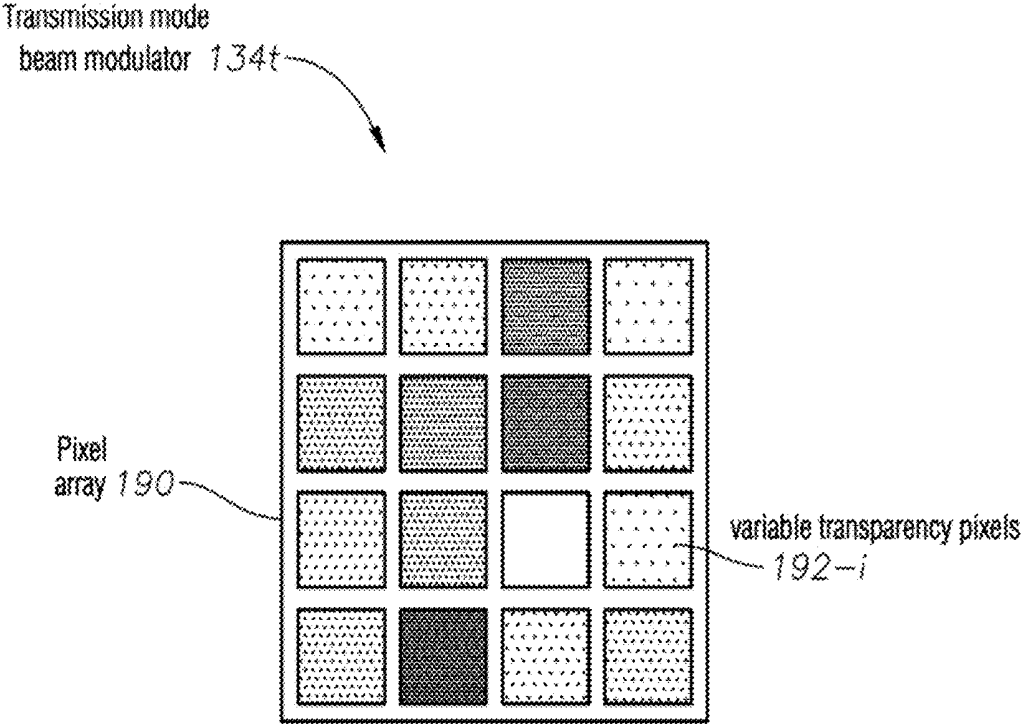

FIG. 9E

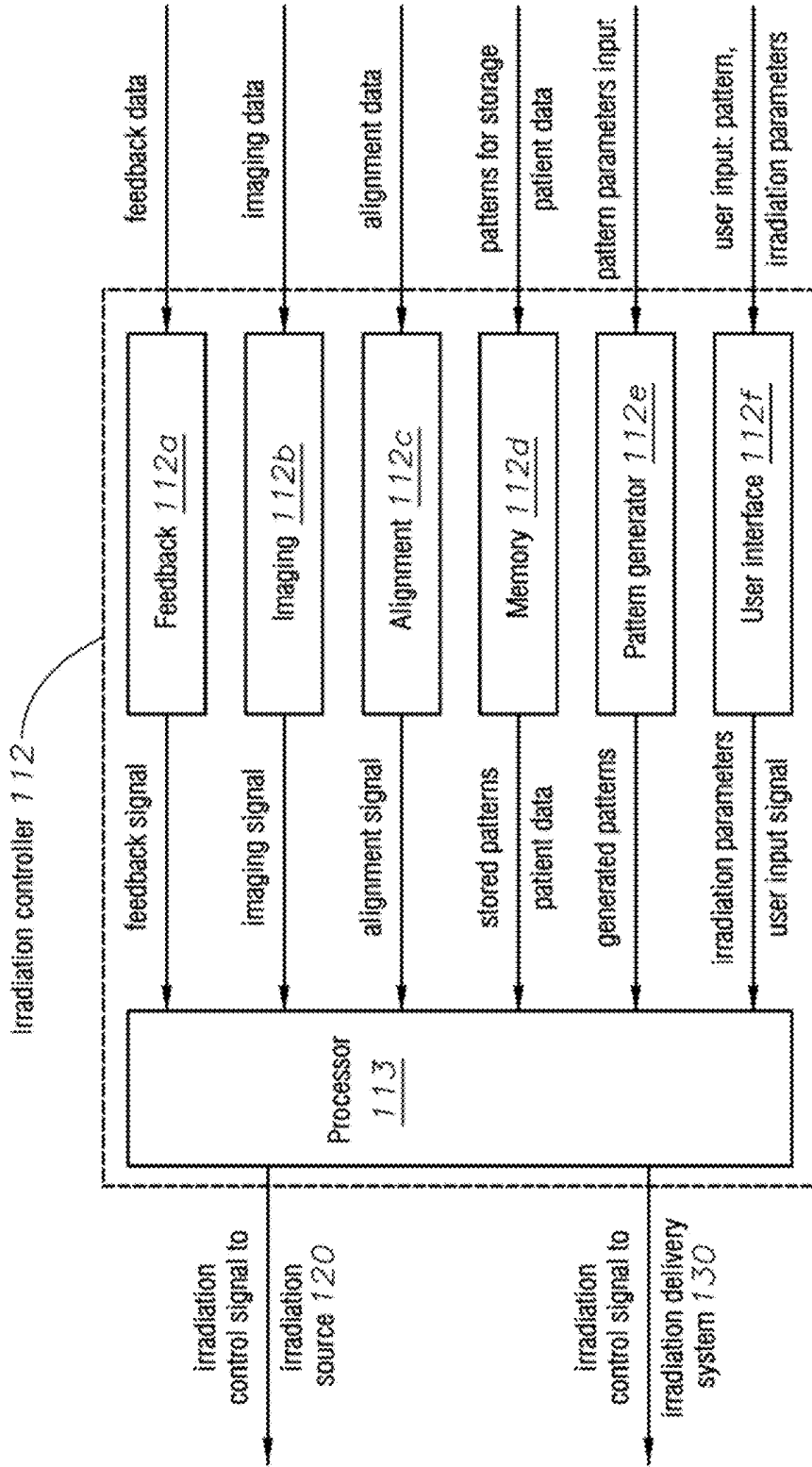

FIG. 10

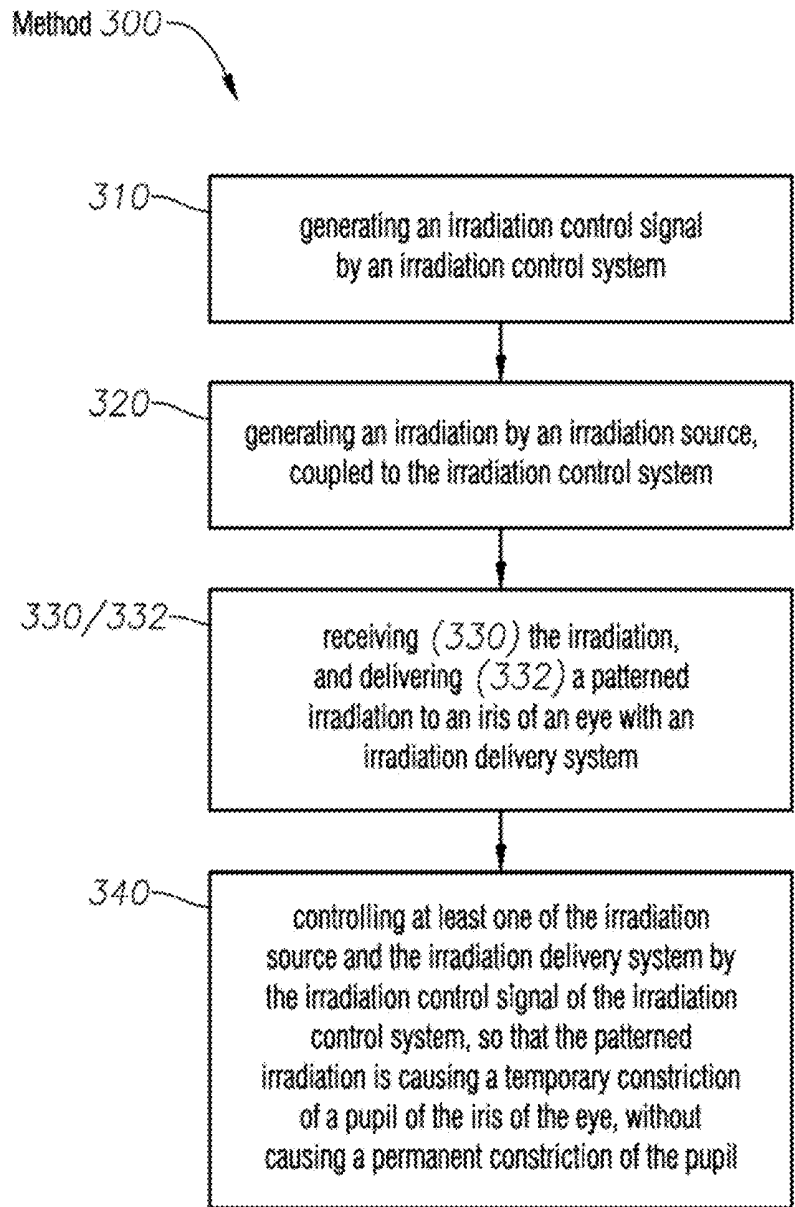

FIG. 11A

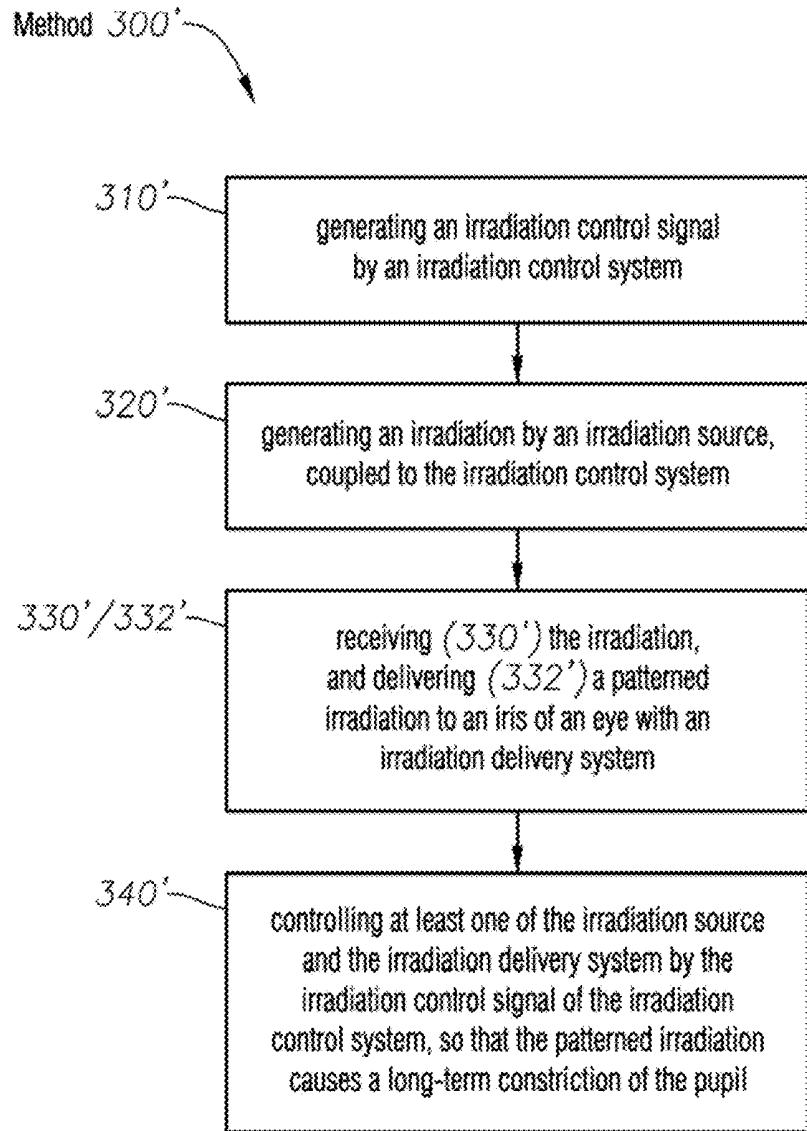

FIG. 11B

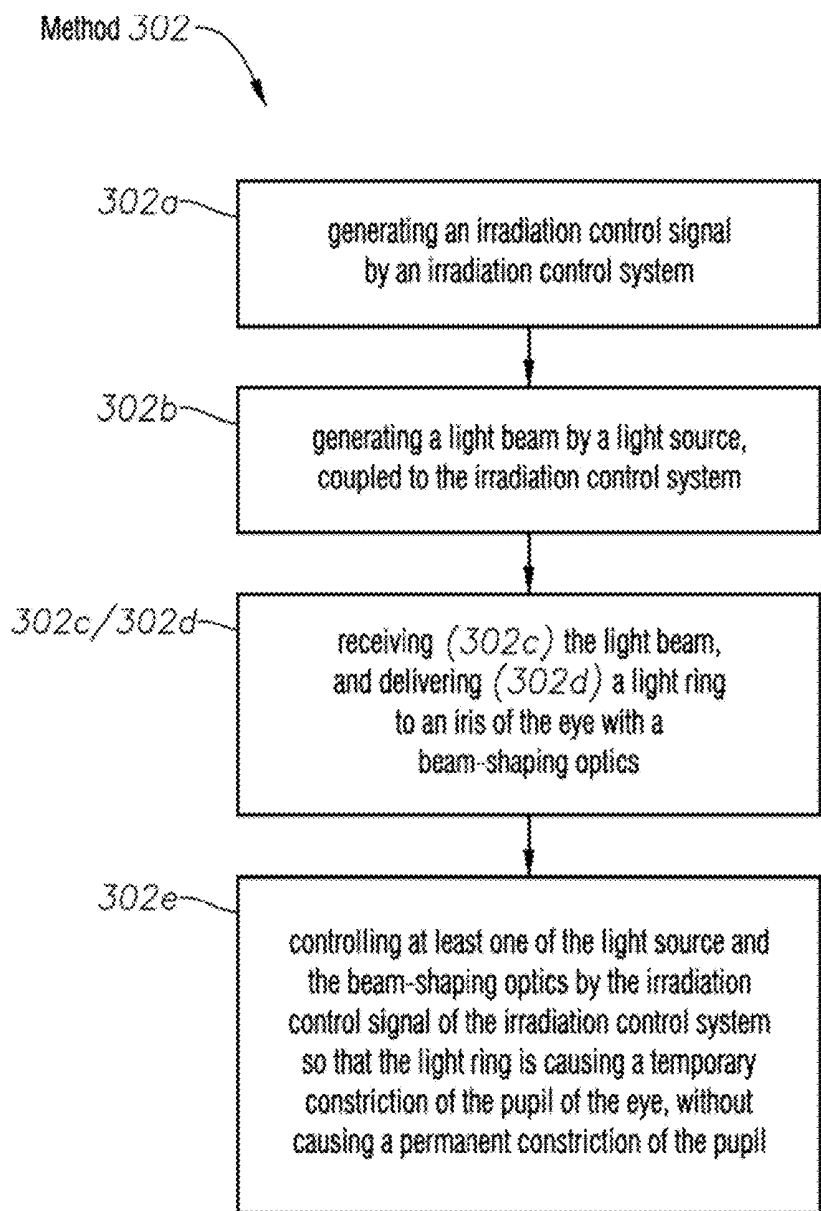

FIG. 11C

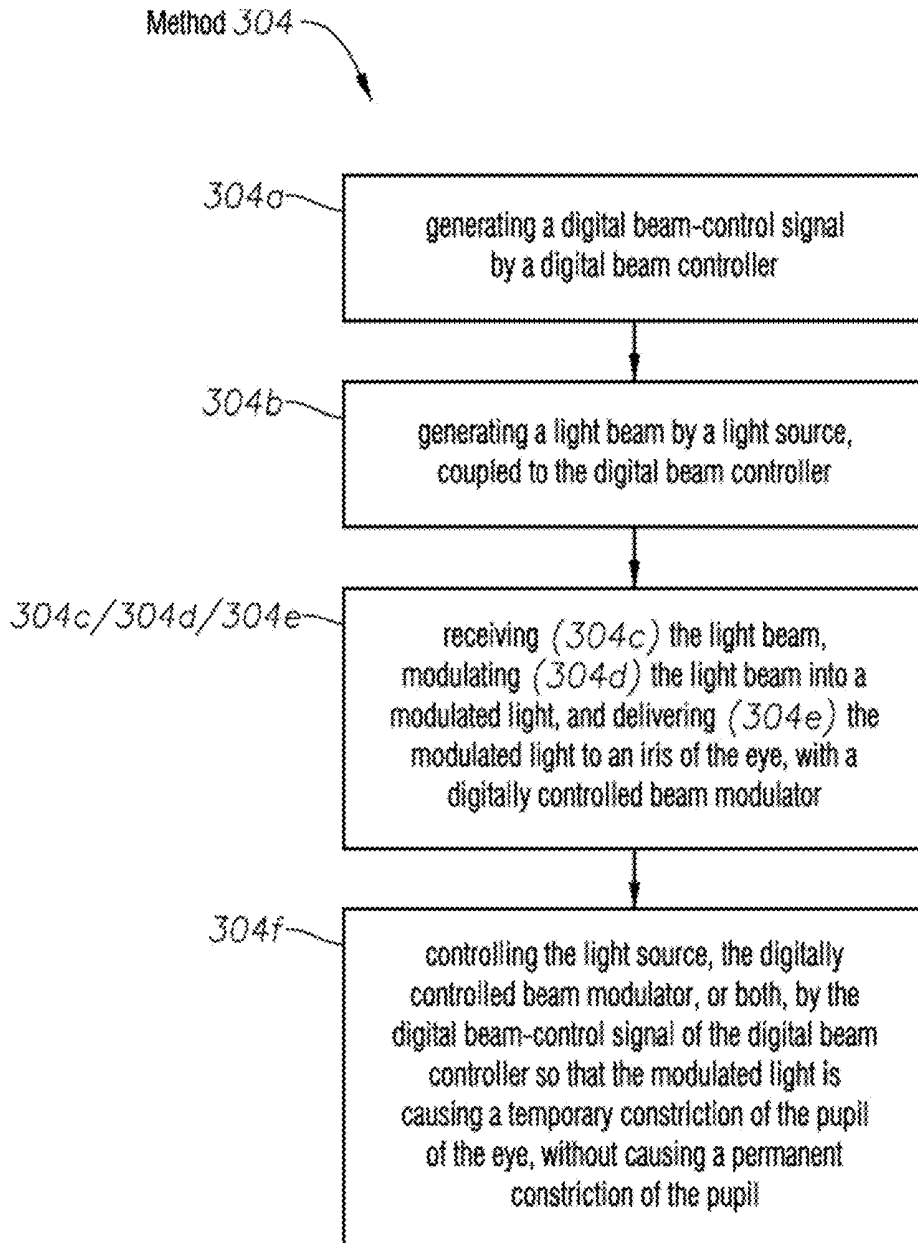

FIG. 11D

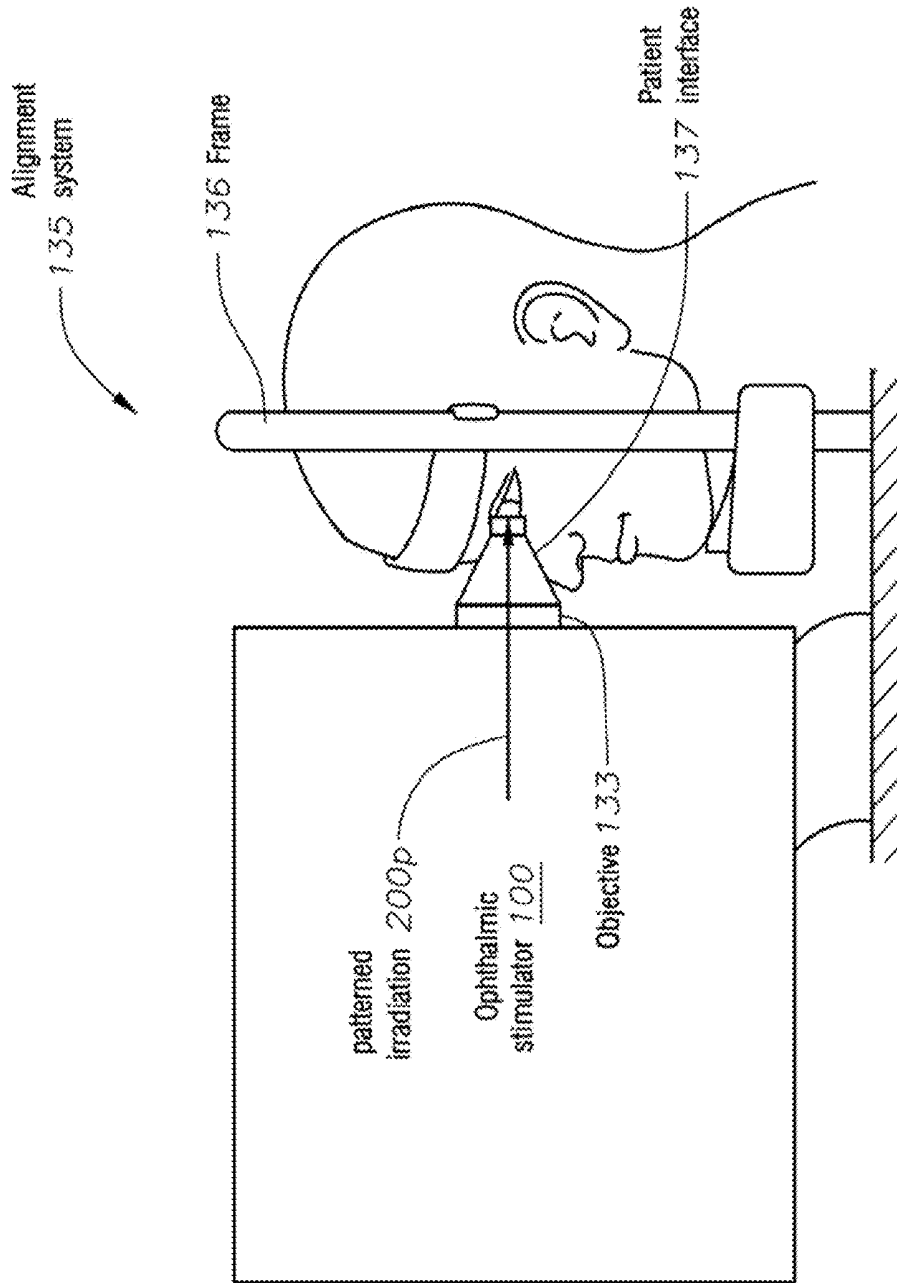

FIG. 12A

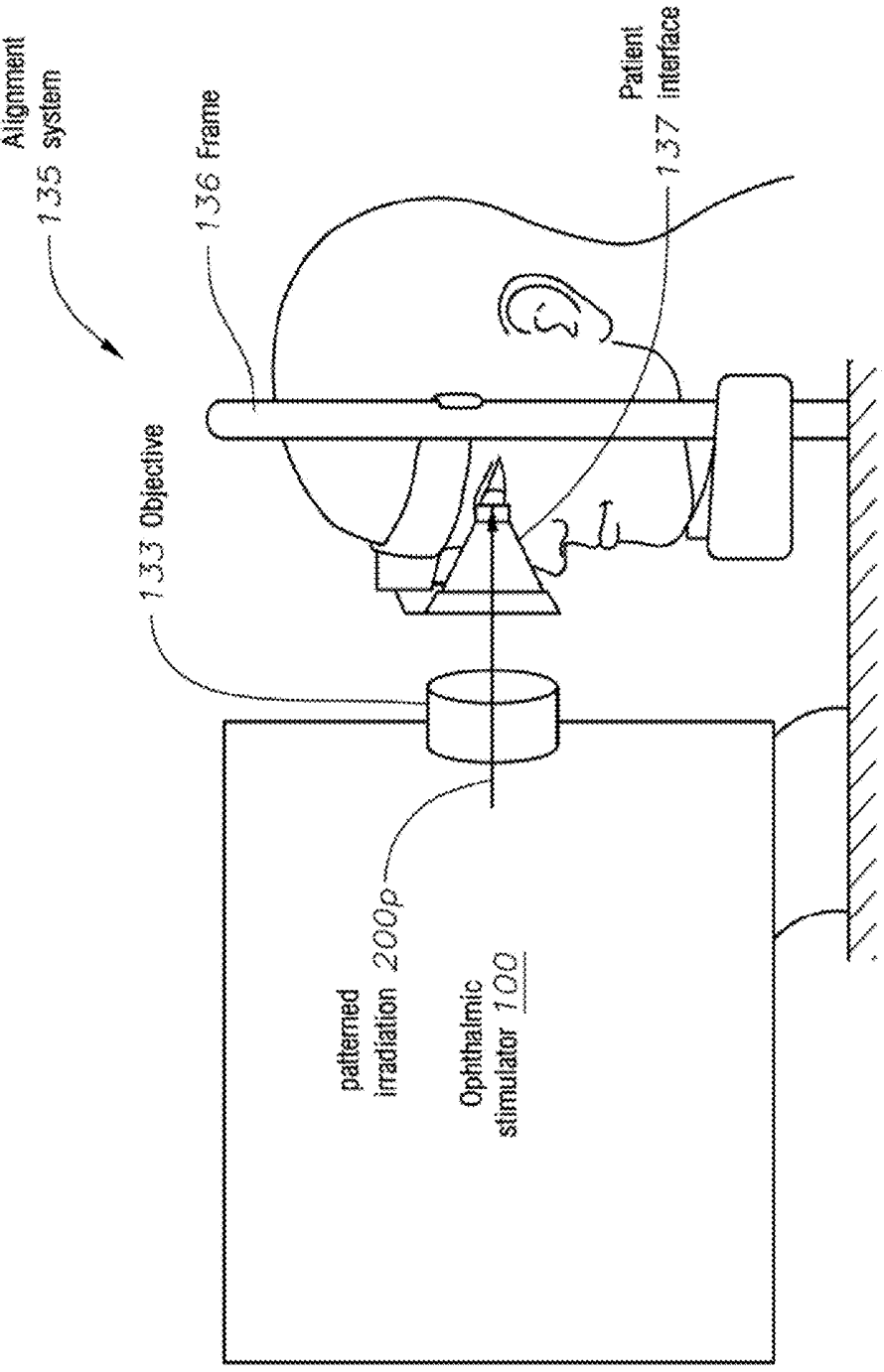

FIG. 12B

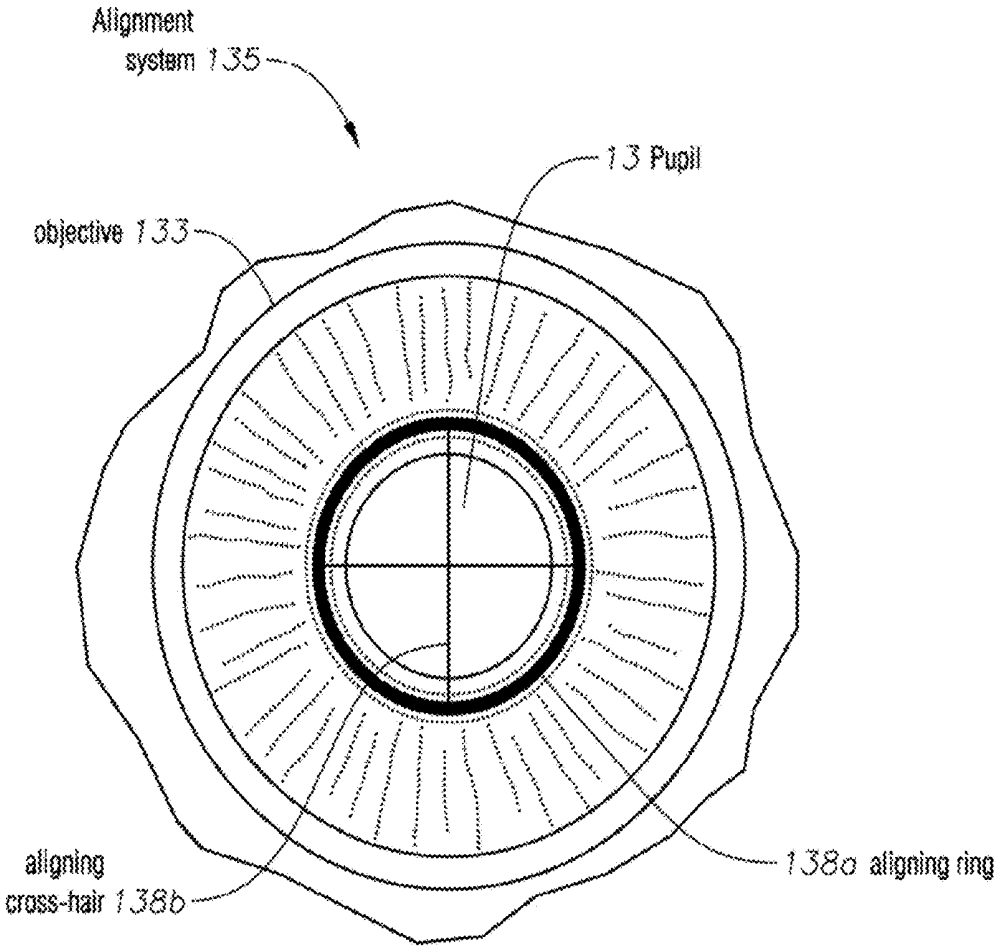

FIG. 12C

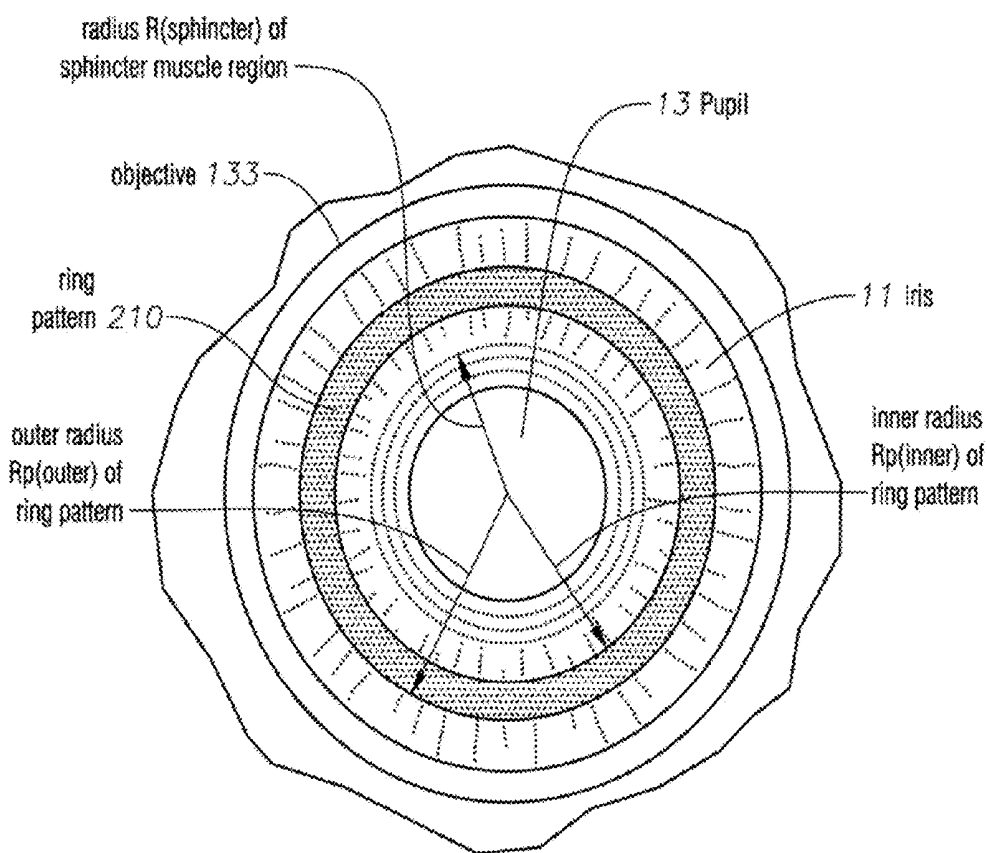

FIG. 12D

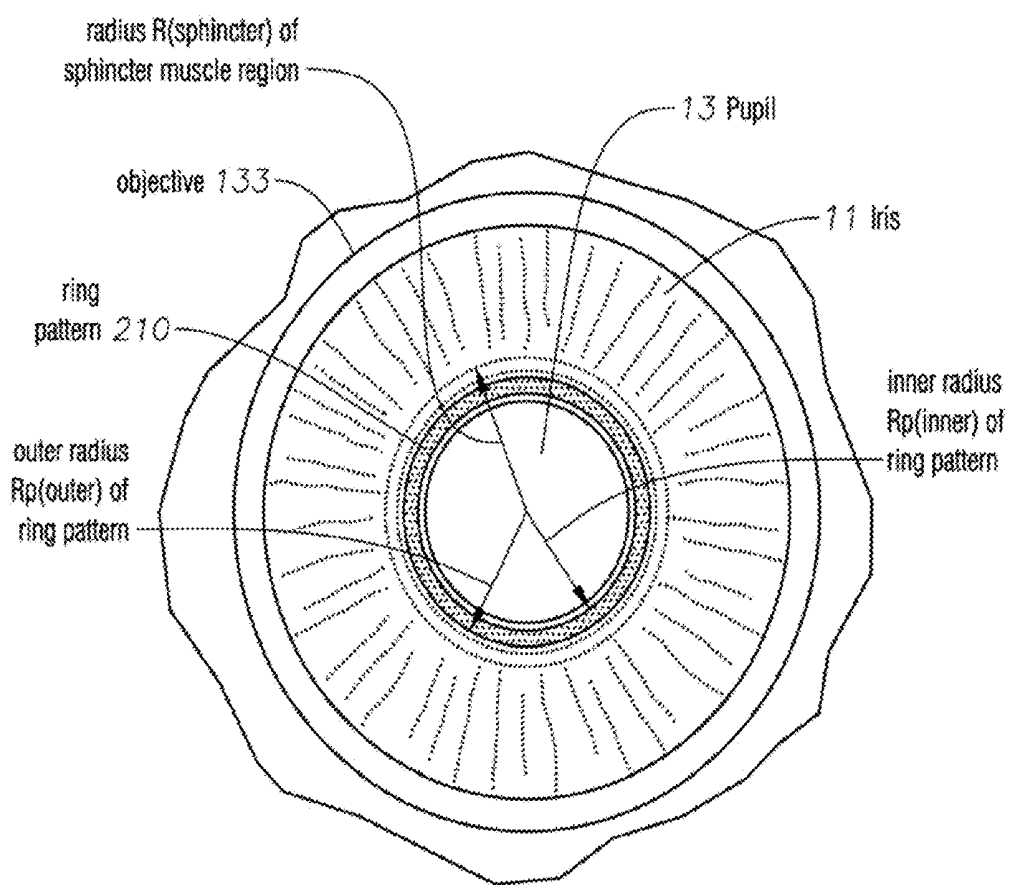

FIG. 12E

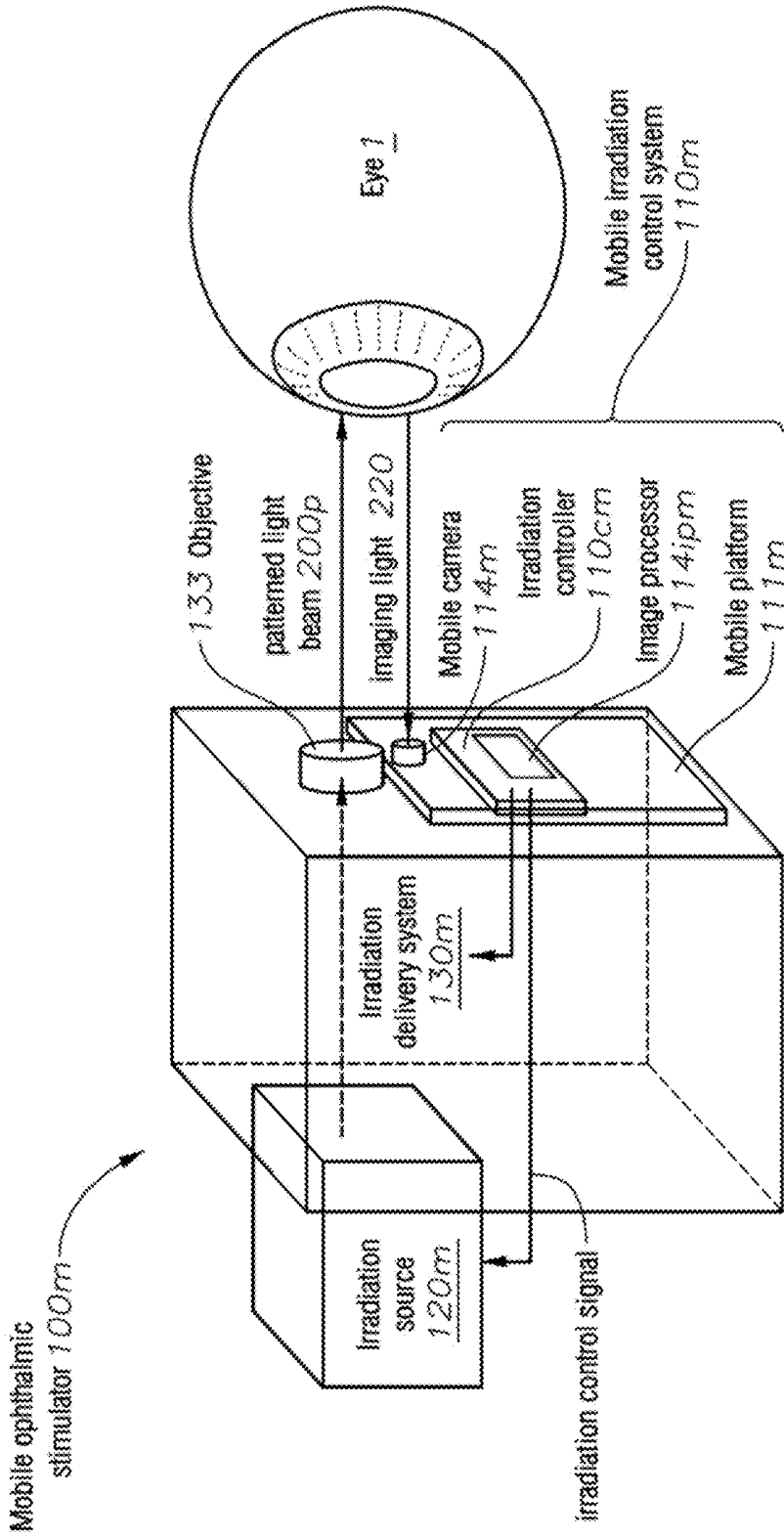

FIG. 13A

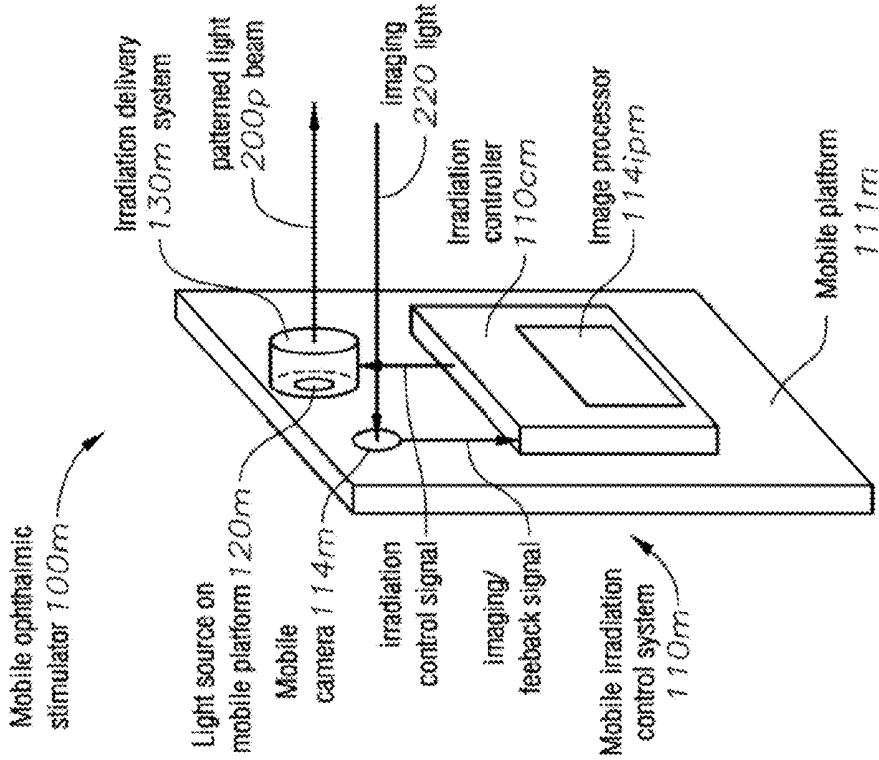

FIG. 13B

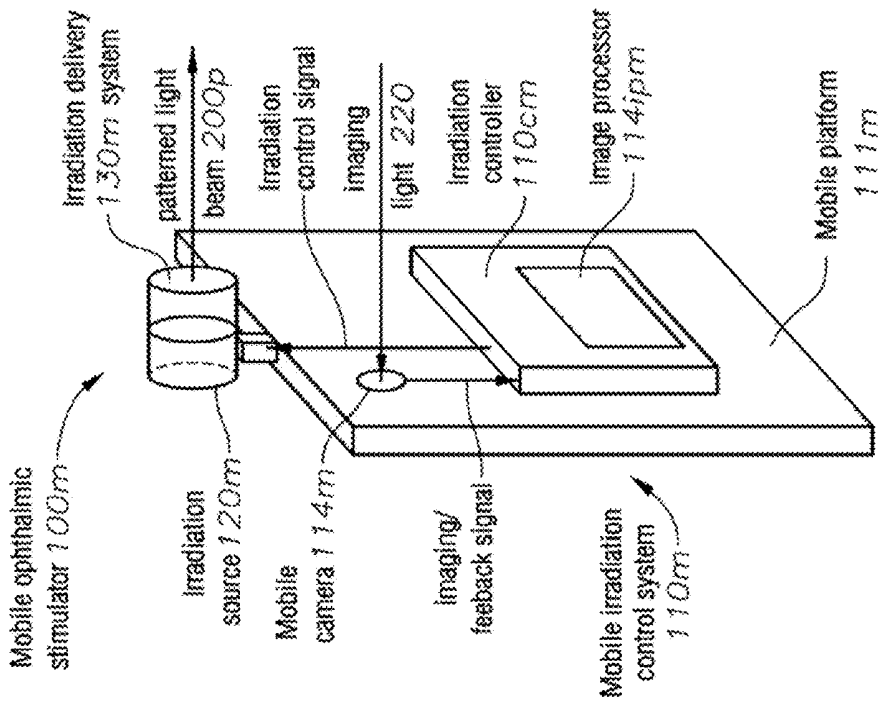

FIG. 13C

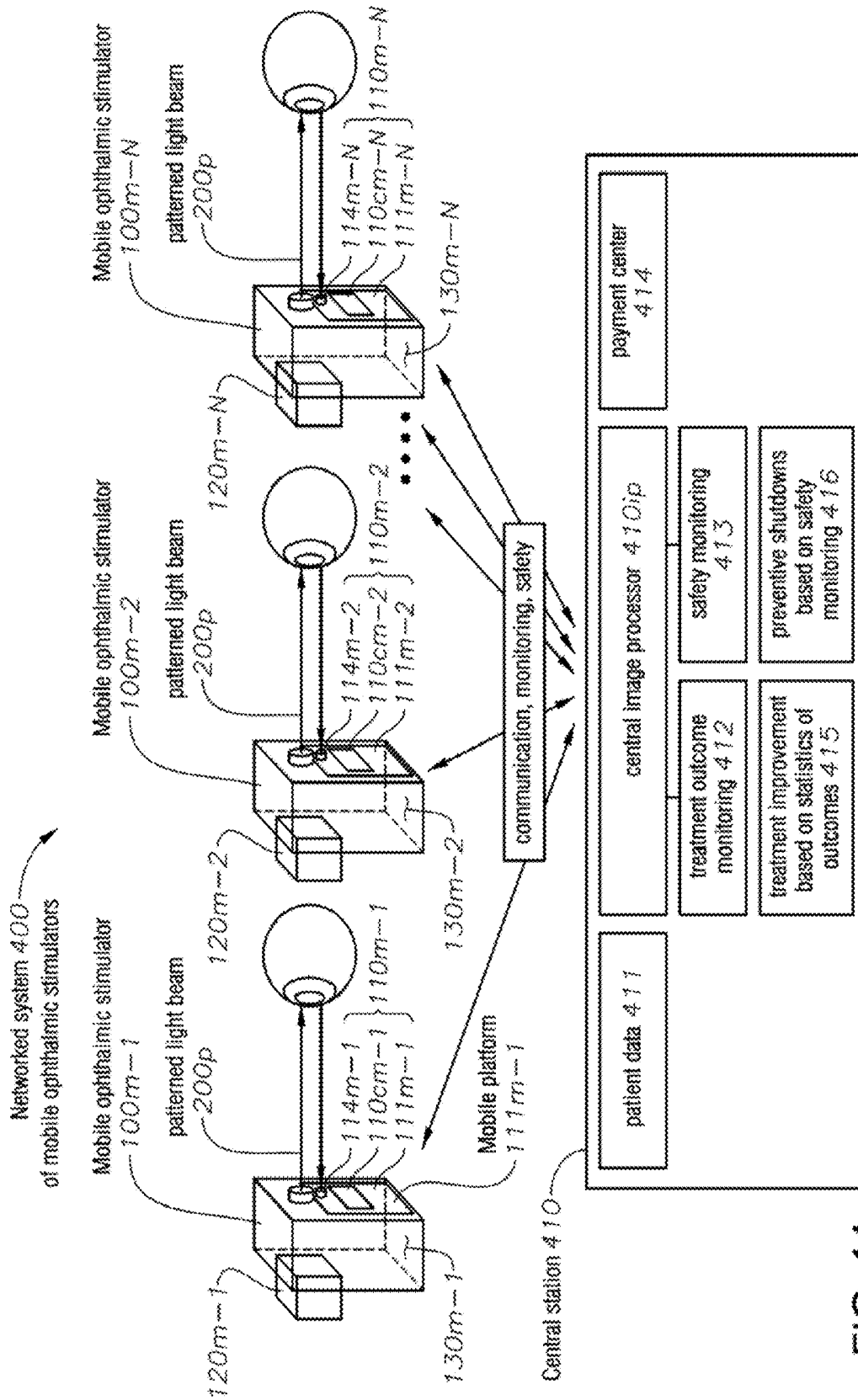

FIG. 14

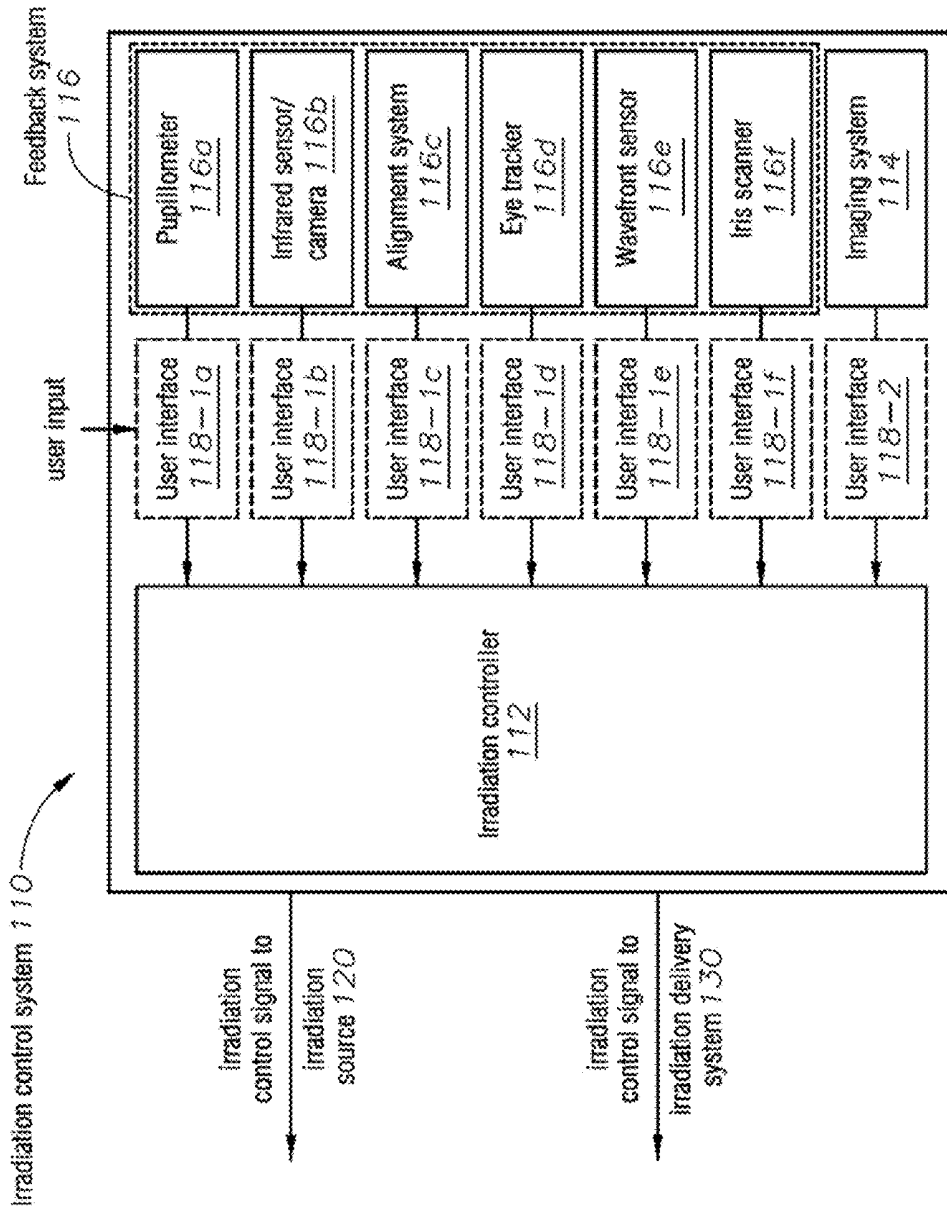

FIG. 15

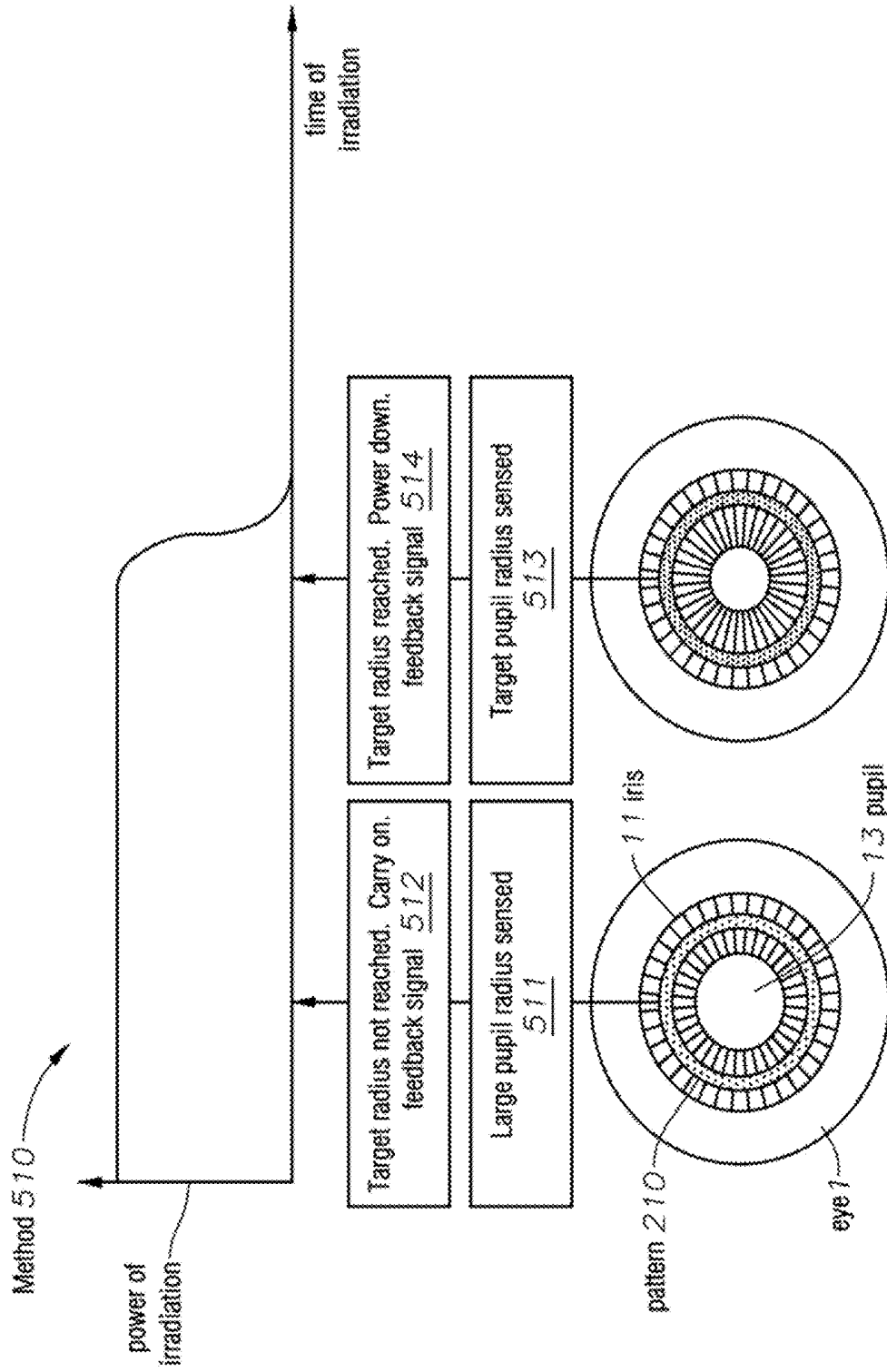

FIG. 16A

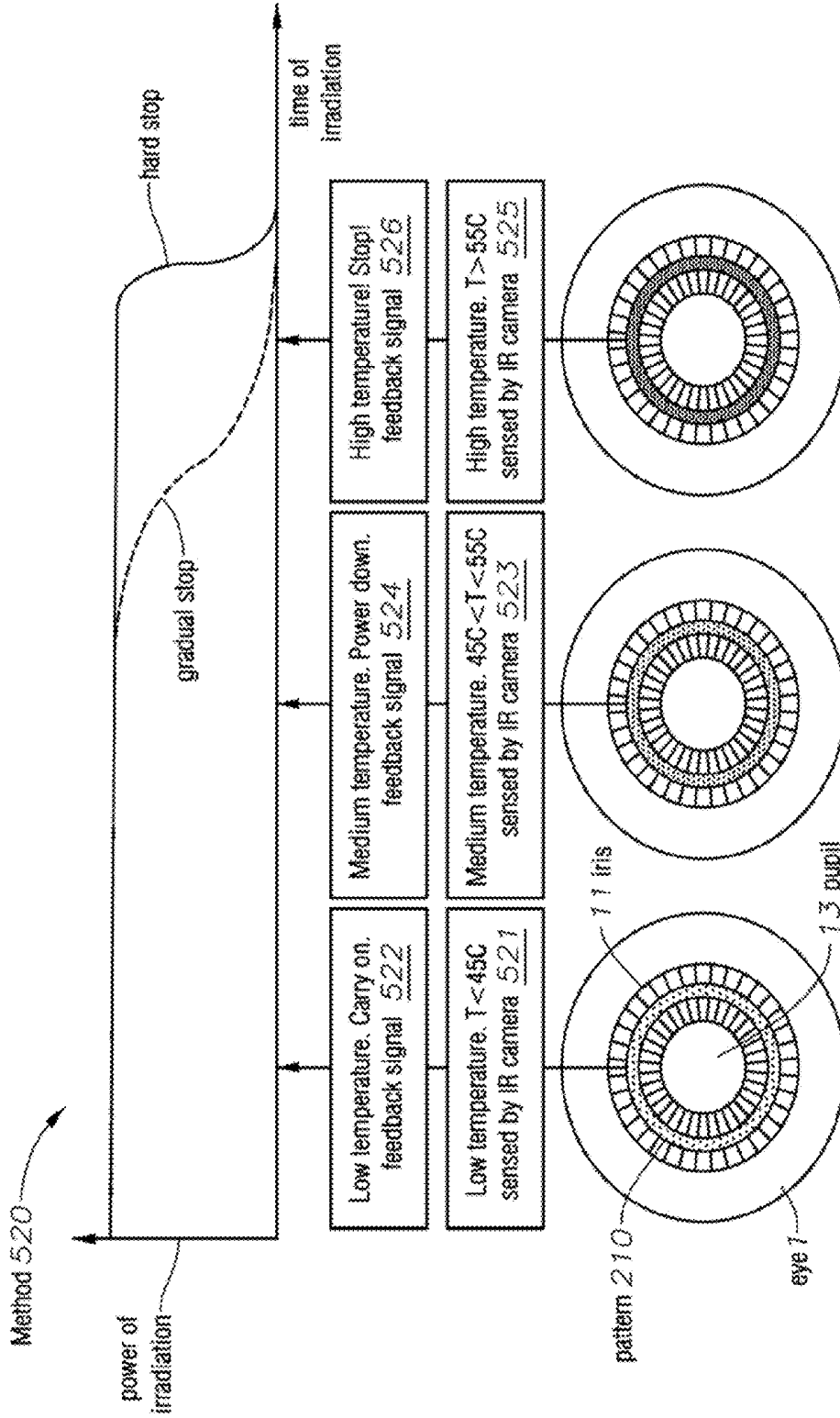

FIG. 16B

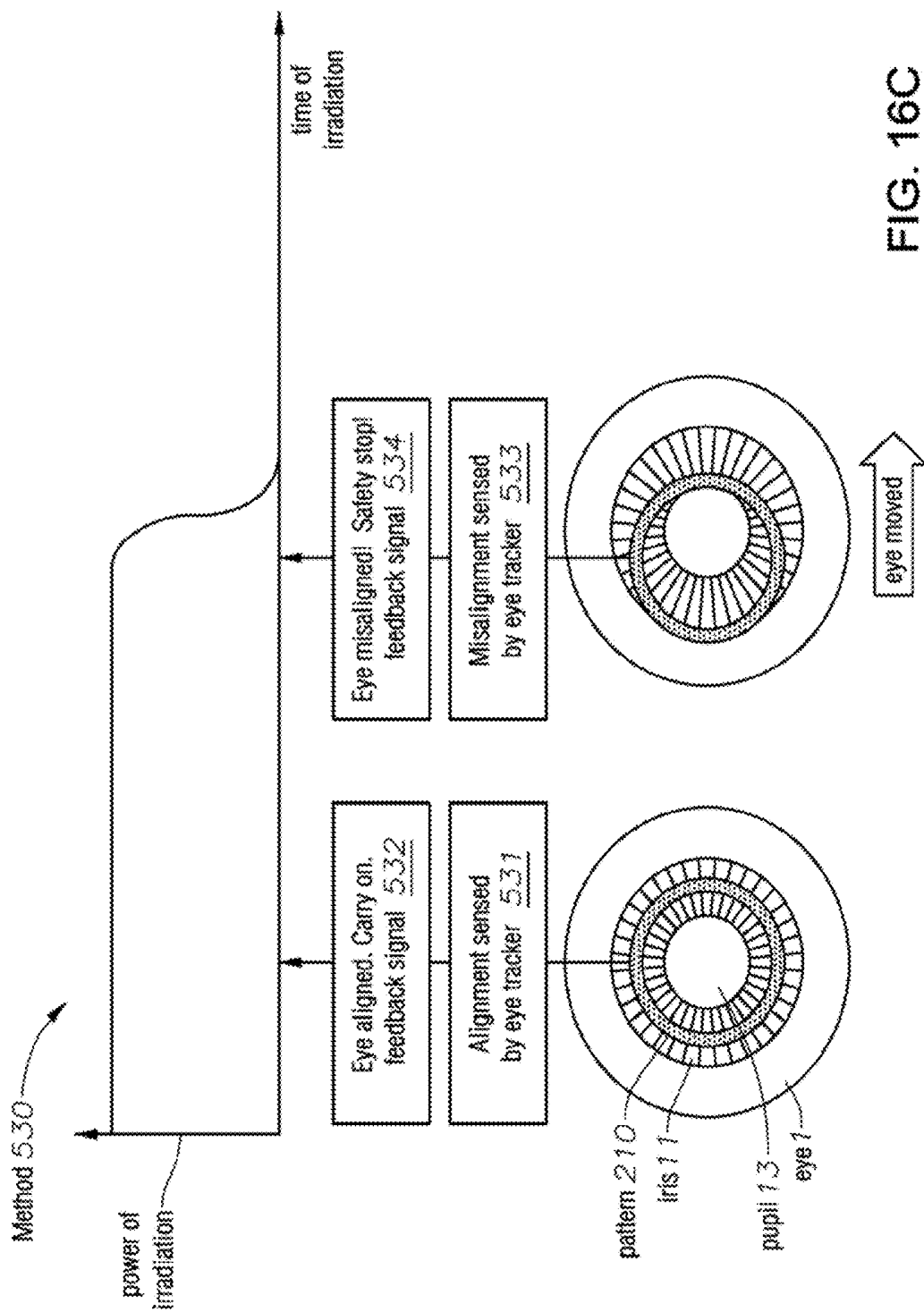

FIG. 16C

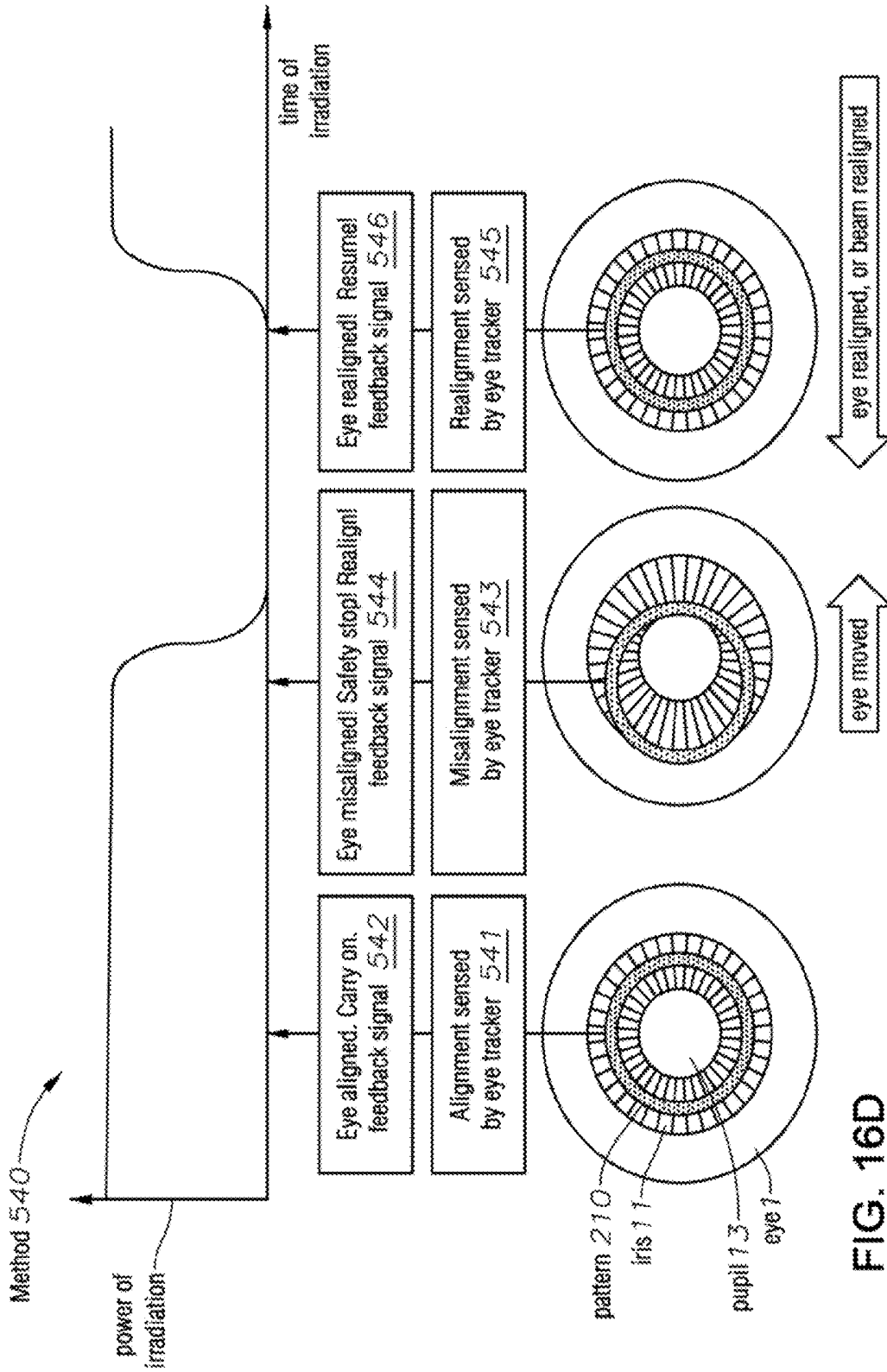

FIG. 16D

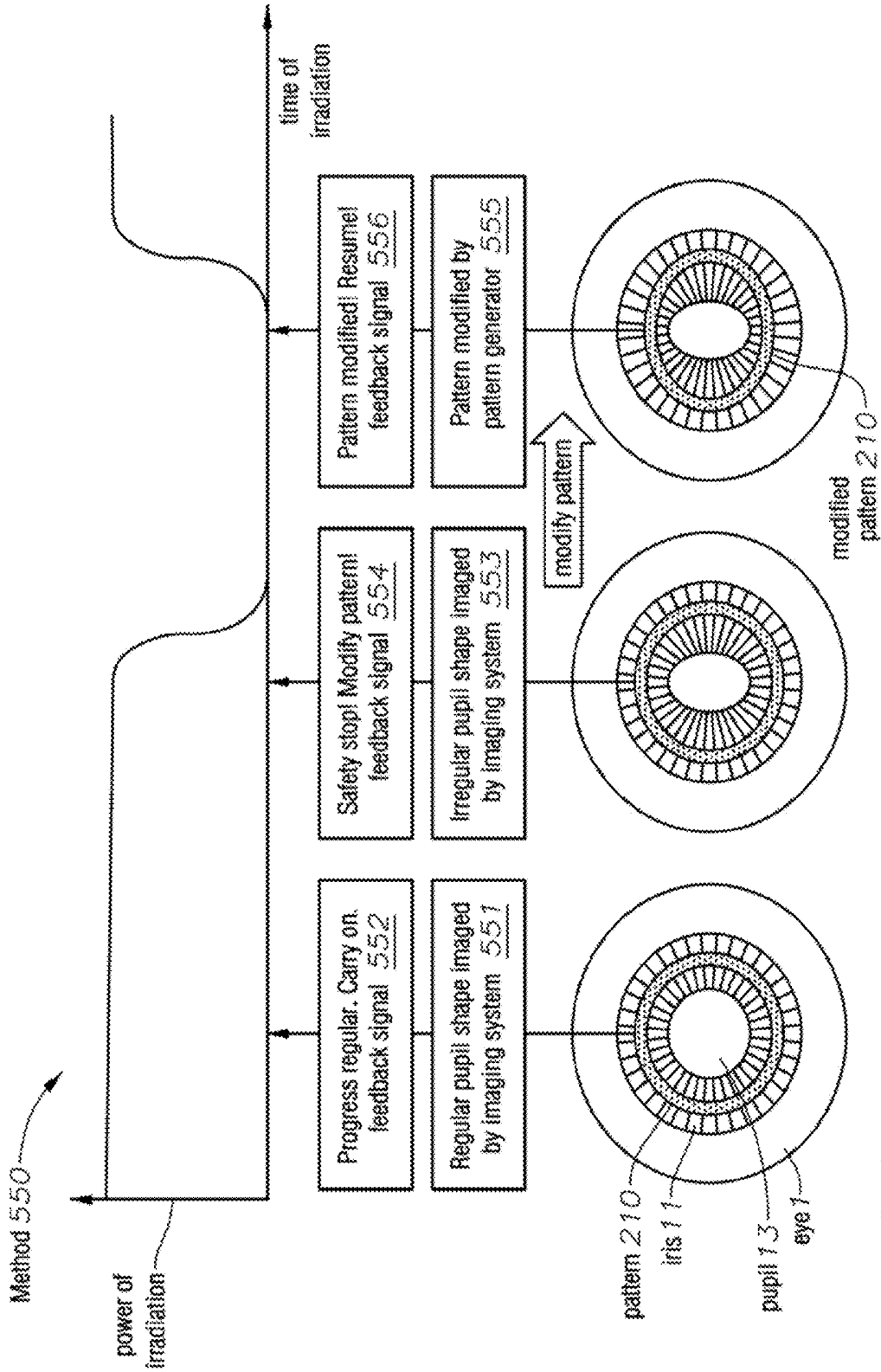

FIG. 16E

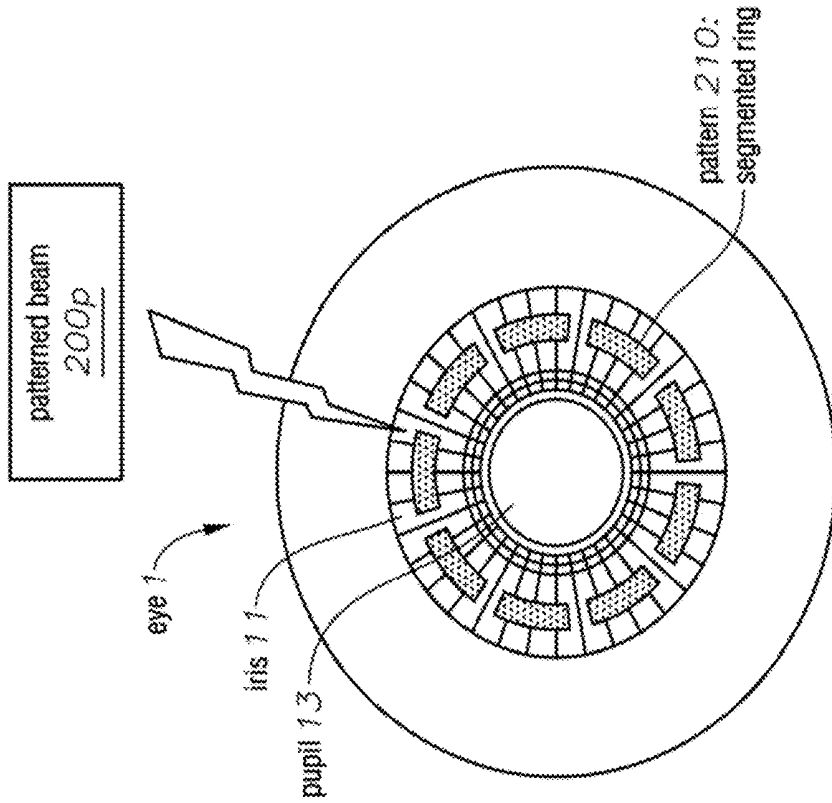

FIG. 17A

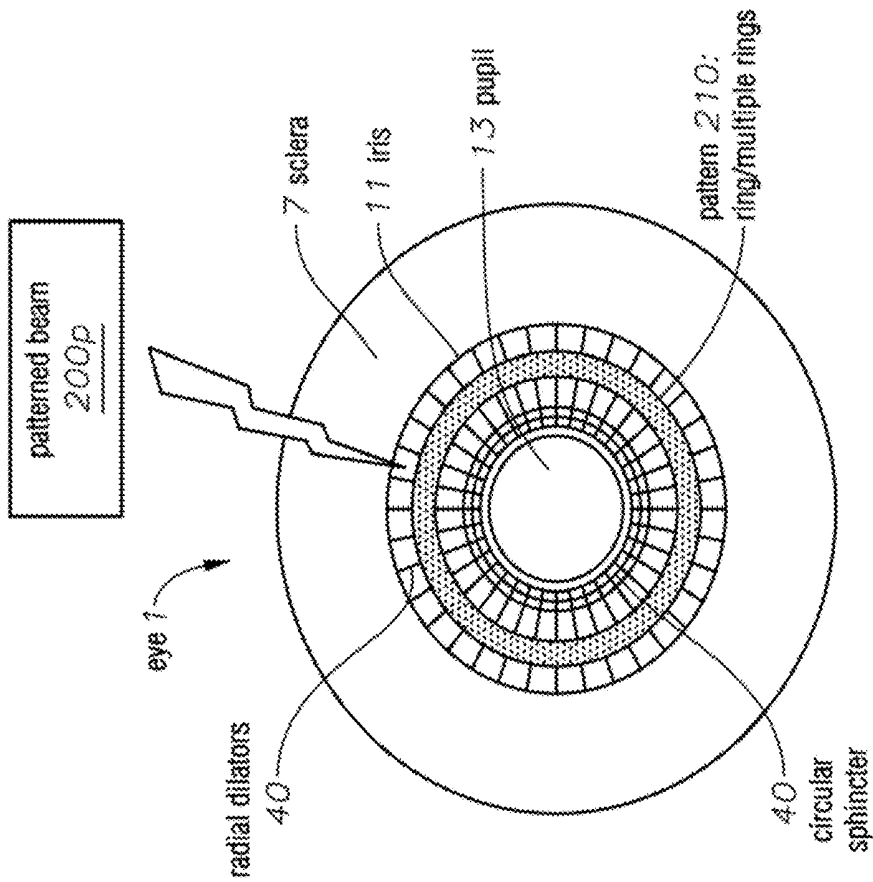

FIG. 17B

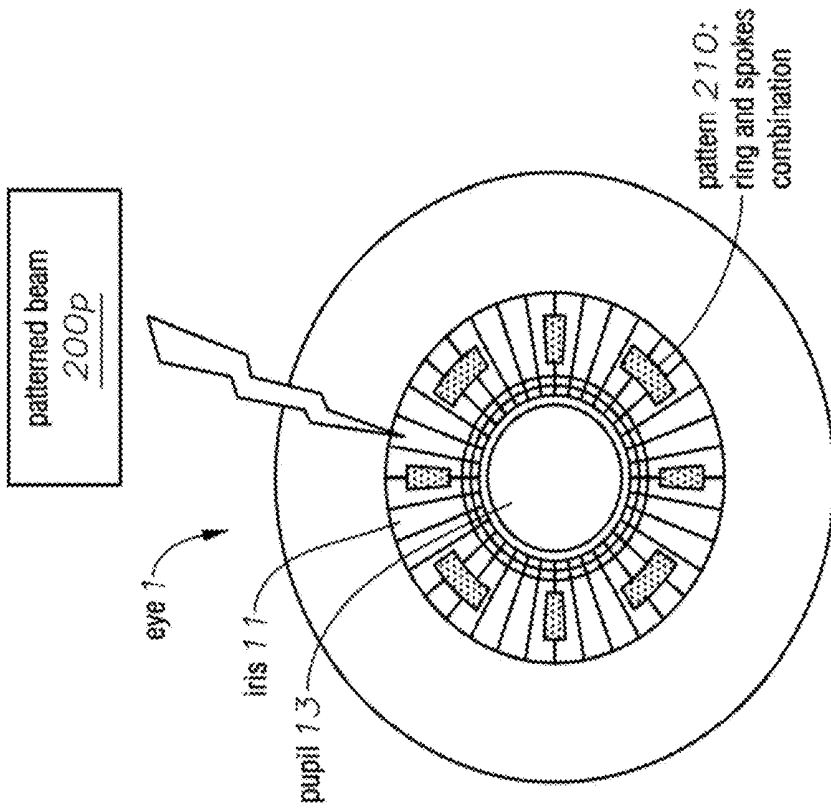

FIG. 17C

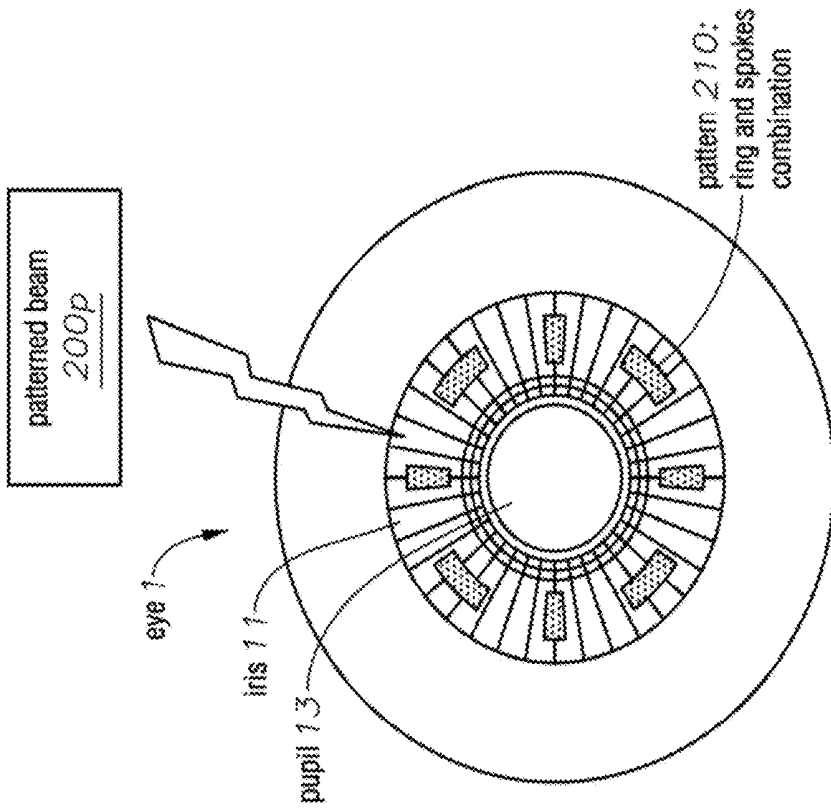

FIG. 17D

**MOBILE PLATFORM FOR
NONPHARMACOLOGIC CONSTRICTION
OF A PUPIL**

CROSS-REFERENCE TO RELATED PATENT
DOCUMENTS

[0001] This application is a continuation-in-part of U.S. patent application: "System for temporary nonpharmacologic constriction of the pupil", by Ronald M. Kurtz and Gergely T. Zimanyi, with application Ser. No.: 15/293,269, filed on Oct. 13, 2016; hereby incorporated by reference in its entirety.

FIELD OF INVENTION

[0002] This invention relates to a system for pupil constriction, more precisely, to a system of temporary, non-pharmacological construction of a pupil of an eye.

BACKGROUND

[0003] A number of devices that, make use of the increased depth of field of a small aperture have been proposed for use in ophthalmology, and developed to improve vision. These devices are particularly promising to improve near vision for those who have presbyopia. Examples of such devices include small aperture corneal inlays, reduced-aperture intraocular lenses, as well as other aperture implants that are meant to impact light propagation along the visual axis. While effective, these surgically implanted permanent inlays carry the risk inherent with any implantable device, such as inflammation, infection, or displacement that may require secondary surgical procedures to remove the implant and may necessitate performing other procedures.

[0004] Pharmacological methods have also been proposed using medications such as pilocarpine and other agents to temporarily constrict the pupil. While these drugs can temporarily improve vision, they generally require frequent instillation of drops, and can be associated with undesirable side effects, such as headaches.

[0005] An alternative approach has been proposed by Hickenbotham in US patent application 2013/0226161, which utilizes a laser to cauterize certain portions of the iris to cause a permanent constriction of the pupil. While this approach offers some advantages over implants and medications, the permanent constriction of the pupil, achieved by a controlled damaging of the iris dilator muscle, does not allow for a trial of the effect, and once performed, leaves the patient with a permanent deficit in iris function. In addition, the exact shape of the constricted pupil may be difficult to control, and may result in odd, irregular, oval, or other undesired pupil shapes. Therefore, the medical need persists to develop a non-pharmacological, non-permanent vision improvement that does not involve inserting a small-aperture object surgically into the eye.

SUMMARY

[0006] In some embodiments, an ophthalmic stimulator for temporarily constricting a pupil of an eye comprises an irradiation control system, to generate an irradiation control signal; an irradiation source, coupled to the irradiation control system, to generate an irradiation; and an irradiation delivery system, coupled to the irradiation control system, to receive the irradiation from the irradiation source, and to

deliver a patterned irradiation to an iris of the eye; wherein the irradiation control system controls at least one of the irradiation source and the irradiation delivery system with the irradiation control signal so that the patterned irradiation causes a temporary constriction of the pupil of the eye, without causing a permanent constriction of the pupil.

[0007] In some embodiments, a method for temporarily constricting a pupil of an eye by an ophthalmic stimulator comprises generating an irradiation control signal by an irradiation control system; generating an irradiation by an irradiation source, coupled to the irradiation control system; receiving the irradiation and delivering a patterned irradiation to an iris of the eye with an irradiation delivery system; and controlling at least one of the irradiation source and the irradiation delivery system by the irradiation control signal of the irradiation control system so that the patterned irradiation is causing a temporary constriction of the pupil of the eye, without causing a permanent constriction of the pupil.

[0008] In some embodiments, an ophthalmic stimulator for constricting a pupil of an eye comprises an irradiation control system, to generate an irradiation control signal; an irradiation source, coupled to the irradiation control system, to generate an irradiation; and an irradiation delivery system, coupled to the irradiation control system, to receive the irradiation from the irradiation source, and to deliver a patterned irradiation to an iris of the eye; wherein the irradiation control system controls at least one of the irradiation source and the irradiation delivery system with the irradiation control signal so that the patterned irradiation causes a long-term constriction of the pupil of the eye.

[0009] In some embodiments, an ophthalmic stimulator for temporarily constricting a pupil of an eye comprises an irradiation control system, to generate an irradiation control signal; a light source, coupled to the irradiation control system, to generate a light beam; and a beam-shaping optics, coupled to the irradiation control system, to receive the light beam from the light source, and to deliver a light ring to an iris of the eye; wherein the irradiation control system controls at least one of the light source and the beam-shaping optics with the irradiation control signal so that the light ring causes a temporary constriction of the pupil of the eye, without causing a permanent constriction of the pupil.

[0010] In some embodiments, an ophthalmic stimulator for temporarily constricting a pupil of an eye comprises a digital beam controller, to generate digital beam-control signal; a light source, coupled to the beam controller, to generate a light beam; and a digitally controlled beam modulator, to receive the digital beam-control signal from the beam controller, to receive the light beam from the light source, and to modulate the received light beam into a patterned light, delivered to an iris of the eye; wherein the beam controller controls at least one of the light source and the digitally controlled beam modulator with the digital beam-control signal so that the patterned light causes a temporary constriction of the pupil of the eye, without causing a permanent constriction of the pupil.

[0011] In some embodiments, an ophthalmic stimulator for temporarily constricting a pupil of an eye comprises an irradiation control system, having a feedback system, to generate an irradiation control signal using a feedback of the feedback system; an irradiation source, coupled to the irradiation control system, to generate an irradiation; and an irradiation delivery system, having a targeting system and coupled to the irradiation control system, to receive the

irradiation from the irradiation source, and to direct a patterned irradiation in a pattern to a treatment region of an iris of the eye using the targeting system; wherein the irradiation control system controls at least one of the irradiation source and the irradiation delivery system with the irradiation control signal so that the patterned irradiation causes a temporary constriction of the pupil, without causing a permanent constriction of the pupil.

[0012] In some embodiments, an ophthalmic stimulator for temporarily constricting a pupil of an eye comprises a mobile irradiation control system, to generate an irradiation control signal; an irradiation source, coupled to the irradiation control system, to generate an irradiation; and an irradiation delivery system, coupled to the mobile irradiation control system, to receive the irradiation from the irradiation source, and to deliver a patterned irradiation to an iris of the eye; wherein the mobile irradiation control system controls at least one of the irradiation source and the irradiation delivery system with the irradiation control signal so that the patterned irradiation causes a temporary constriction of the pupil of the eye, without causing a permanent constriction of the pupil.

[0013] In some embodiments, a networked system of ophthalmic stimulators for temporarily constricting eye-pupils comprises a set of ophthalmic stimulators, each ophthalmic stimulator including a mobile irradiation control system, to generate an irradiation control signal; an irradiation source, coupled to the irradiation control system, to generate an irradiation; and an irradiation delivery system, coupled to the mobile irradiation control system, to receive the irradiation from the irradiation source, and to deliver a patterned irradiation to an iris of the eye; wherein the mobile irradiation control system controls at least one of the irradiation source and the irradiation delivery system with the irradiation control signal so that the patterned irradiation causes a temporary constriction of the pupil of the eye, without causing a permanent constriction of the pupil; and a central station, including a central image processor, wherein the mobile irradiation control systems of the of the ophthalmic stimulators and the central station are configured to communicate through a communication network.

BRIEF DESCRIPTION OF THE FIGURES

[0014] FIG. 1 illustrates an eye 1.

[0015] FIGS. 2A-B illustrate the pupil under different illuminations.

[0016] FIGS. 3A-B illustrate an effect of applying an irradiation to the iris.

[0017] FIGS. 4A-B illustrate the effect of irradiation on the muscle response.

[0018] FIGS. 5A-B illustrate embodiments of the ophthalmic stimulator 100, and the permanent ophthalmic stimulator 100'.

[0019] FIGS. 6A-D illustrate embodiments of the ophthalmic stimulator 100.

[0020] FIGS. 7A-F illustrate embodiments of the ophthalmic stimulator 100 with a beam shaping optics 134.

[0021] FIGS. 8A-B illustrate embodiments of the ophthalmic stimulator 100 with a digital beam controller 110.

[0022] FIGS. 9A-E illustrate embodiments of the beam modulator 134.

[0023] FIG. 10 illustrates an irradiation controller 112.

[0024] FIGS. 11A-D illustrate steps of the methods 300, 300', 302, and 304.

[0025] FIGS. 12A-E illustrate embodiments of the alignment system 135.

[0026] FIGS. 13A-C illustrate mobile embodiment of the ophthalmic stimulator 100.

[0027] FIG. 14 illustrates a mobile network of self-treatment stimulators 400.

[0028] FIG. 15 illustrates an embodiment of the feedback system, 116.

[0029] FIGS. 16A-E illustrate methods 510-550.

[0030] FIGS. 17A-D illustrate various irradiation patterns 210.

DETAILED DESCRIPTION

[0031] Embodiments of the invention address the above described needs in the following manner. Some embodiments provide systems and methods for a temporary constriction of the pupil without the need of medication therapy. The duration of the constriction can be controlled by a selection of treatment parameters. In a suitable range of treatment parameters, the procedure can be fully reversible: after a characteristic time, the pupils return to essentially their original diameter without further treatment. The pupils can be re-constricted by applying the treatment repeatedly. Therefore, the here-described methods and devices provide the advantages of a temporary, but long lasting vision improvement, while avoid the hazards associated with (1) aperture implants and inlays, inserted by a surgical procedure, (2) permanent destruction of tissue, and (3) pharmaceutical approaches and their undesirable side-effects.

[0032] Some embodiments achieve these advantages by heating the iris by an irradiation to a suitable temperature range, (1) to cause a temporary inactivation of the iris dilator muscle, and, in some cases, (2) to enhance an action of the iris constrictor sphincter muscle. This irradiative heat treatment can be applied for a time sufficiently long to cause a reduction in contractile activity, but short enough to avoid causing permanent tissue damage. While the detailed mode of action is yet to be clarified, this effect may be mediated by inactivation of the actin-myosin complex in the exposed muscle.

[0033] FIG. 1 shows a cross section of an eye 1. The eye 1 includes the well known constituents: a cornea 5, where light enters the eye 1, and a sclera 7, an opaque, fibrous protective outer layer of the eye 1 that contains collagen and elastic fibers. Distal to the cornea 5 is an anterior chamber 9 that contains an aqueous humor. The anterior chamber 9 is separated from a posterior chamber 15 by an iris 11. An opening at a center of the iris 11 is a pupil 13 that allows the light to proceed toward the posterior segment of the eye 1. Behind the pupil 13, ciliary muscles 17 hold a lens 19 in a central position. These ciliary muscles 17 can also deform the lens 19 as pail of accommodating the vision to the distance of the target the eye is looking at. With advancing age, the ciliary muscles 17 slowly loose their ability to deform and adapt the lens 19 to varying vision distances: a condition typically referred to as presbyopia. Behind the lens 19 is a vitreous 21. As the light crosses the vitreous 21, it eventually hits the retina 23. The electric stimuli, generated by the incoming light in the retina 23, are transmitted by the optic nerve 25 towards the brain.

[0034] FIG. 2A-B illustrate that the iris 11 includes a circular sphincter muscle 40 around the pupil 13, capable of shrinking the perimeter of the pupil 13, thus constricting it. At the same time, the iris 11 also includes radial dilator

muscles **30** that specialize in expanding, or enlarging, the pupil **13**. The competition of the sphincter muscles **40** and dilator muscles **30** determines the eventual radius of the pupil **13**. FIG. 2A illustrates in its left panel that in strong light the contracting sphincter muscles **40** constrict the pupil **13**. FIG. 2A illustrates in its middle panel the pupil **13** in an average light. FIG. 2A illustrates in its right panel that in low light conditions, the radial dilator muscles **30** dominate the sphincter muscles **40** and dilate the pupil to enhance the amount of light directed to the retina **23**.

[0035] FIG. 2B illustrates a cross section of the iris **11** from the side. It is well visible that the sphincter pupillae **40** is positioned along the edge of the pupil **13**, the pupillary ruff, while the radial dilator pupillae **30** are located radially outward, farther from the edge of the pupil **13**.

[0036] The anatomy of the muscles of the iris **11** is also important. The dilator muscle **30** fibers are typically located near the distal portion of the iris **11**, adjacent to the iris pigmented epithelium. In contrast, the constrictor sphincter muscles **40** are more superficial and central, located towards the pupil's edge or margin. Details of the anatomy of these muscles can be found in much greater detail in Junqueira L C., Carneiro 2005. Basic Histology, Eleventh Edition. The McGraw-Hill Companies, Inc. United States of America,

[0037] FIGS. 3A-B illustrate a principle of embodiments of the invention. FIG. 3A illustrates that a patterned irradiation can be applied to the iris **11** for a limited time period, such as 1-100 seconds, with less time required when higher temperatures are applied. The pattern is typically a ring of light, or light-ring. The irradiation raises the temperature of the iris **11** in a treatment region. The tissue of the iris **11** can be heated to temperatures that are not sufficient to cauterize or destroy the tissue, but are capable of reducing an activity, or responsiveness of the targeted tissues.

[0038] FIG. 3B illustrates the outcome of the irradiation. The heat treatment reduces the activity of the iris dilator muscle and this allows the pupillary constrictor, or sphincter, muscle to reduce the pupil's diameter. Reducing the pupil's diameter reduces the aberrations of the imaging of the eye, sometimes referred to as the pinhole effect in optics. Reducing the aberrations extends the depth of focus, and thereby compensates the emergence of presbyopia in an aging eye. Since this method utilizes the natural constrictor muscle to effect the pupil size change, the risk of pupil de-centration is less than in the case of surgical implants, discussed previously.

[0039] FIGS. 4A-B illustrate that heat treatments have been already studied and demonstrated to reduce muscle activity in human tissues, such as in the lung and the prostate, which have smooth muscle tissues similar to that of the iris. The heat treatment can reduce, or inhibit, muscle activity in these tissues. The duration of inactivity can last for hours to days in these systems (see Am. J. Respir. Cell Mol. Biol. Vol 44. pp 213-221, 2011). FIG. 4A illustrates the effect of heat treatments on lung smooth muscle. The muscle tissue was heated for a treatment time between 5 s and 60 s. After the heat treatment, a test stimulus was administered to the heat-treated and the untreated muscles. The graph reports the ratio of responses to this test as a function of the treatment temperature of the tissue. Visibly, as the treatment temperature exceeded 50 Celsius, or Centigrade, the response of the treated muscle to the test stimulus gradually

decreased. For heat treatments above 55-60 Celsius, the response became negligible: the muscle was deactivated by the treatment.

[0040] FIG. 4B illustrates the same ratio of responses of treated muscles to non-treated muscles, with the difference that it indicates how long the effect lasted. As the curves show, the de-activation of the smooth muscle with heat treatments raising the muscle temperature above 50-55 Celsius lasted at least for 28 hours, and possibly longer. This remarkably long-lasting deactivation of smooth muscle in response to such a mild and short temperature increase is utilized by embodiments described in this document.

[0041] FIG. 5A illustrates an ophthalmic stimulator **100** for temporarily constricting a pupil **13** of an eye **1**, building on the just-described observations, comprising an irradiation control system **110**, to generate an irradiation control signal; an irradiation source **120**, coupled to the irradiation control system **110**, to generate an irradiation **200**; and an irradiation delivery system **130**, coupled to the irradiation control system **110**, to receive the irradiation **200** from the irradiation source **120**, and to deliver a patterned irradiation **200p** to an iris **11** of the eye **1** in a pattern **210**. In embodiments, the irradiation control system **110** controls at least one of the irradiation source **120** and the irradiation delivery system **130** with the irradiation control signal so that the patterned irradiation **200p** causes a temporary constriction of the pupil **13** of the eye **1**, without causing a permanent constriction of the pupil **13**.

[0042] The irradiation control system **110** can include a memory, to store executable programs and applications; a processor, to execute at least one of a stored program and an installed application; and a user interface, to receive input from a user in relation to an operation of the memory and the processor.

[0043] In some embodiments of the ophthalmic stimulator **100**, the irradiation source **120** can include an incoherent light source, such as a light source, a LED, a lamp, an infrared source, a broad-band source, a narrow-hand source, a radio-frequency source, an electromagnetic radiation source, or a sound source, to generate a light beam, an electromagnetic irradiation, an infrared beam, a LED light, or a sound. A separate class of irradiation sources can include a coherent light source, such as a laser, a pulsed laser, or a continuous wave (CW) laser.

[0044] The just discussed classes of incoherent and coherent irradiation sources have different advantages and drawbacks. Lasers offer good control and unparalleled precision. At the same time, laser beams have a very small diameter, often less than 100 microns. Therefore, to affect larger treatment regions, they require a complex and expensive, digitally controlled optical system, such as a scanning system. These laser-plus-scanning systems offer great control and precision. At the same time, they can be expensive, and can introduce multiple sources of unreliability and performance degradation, a potential problem in medical applications, where high reliability is essential. Using lasers and scanners may therefore necessitate regular maintenance. Also, laser beams can be very intense, thus if a laser gets pointed to an unintended part of an ophthalmic tissue, it can cause substantial damage. Therefore, much stronger safety systems and precautions are needed in laser systems.

[0045] In contrast, non-coherent light sources, such as LEDs, infrared sources, lamps, infrared sources, and others may offer less precision and control. However, this control

may be sufficient for the purposes of the here-described treatment. Also, incoherent light sources can make the ophthalmic stimulator **100** much simpler, lighter, and smaller at the same time. Since they typically do not require a digitally controlled scanning system, these incoherent light sources can also be cheaper to maintain and can be more robust and reliable. Finally, since these light sources are less intense, systems with incoherent light sources may require less stringent safety systems and measures. All in all, a comparative analysis of the competing advantages and disadvantages is performed when a system designer decides whether to use a coherent, or an incoherent light source as the irradiation source **120** of the ophthalmic stimulator **100**.

[0046] Embodiments of the ophthalmic stimulator **100** can be characterized by numerous treatment parameters. These treatment parameters can include the followings. A power density of the patterned irradiation **200p** of the irradiation delivery system **130** can be in the range of 0.1-1000 mW/cm², in some designs in the range of 1-100 mW/cm². A total power delivered by the patterned irradiation **200p** to the iris can be in the range of: 0.1-1,000 mW, in some designs in the range of 1-100 mW. A total energy, deposited by the patterned irradiation **200p** during the treatment can be in the range of 10 microJ-10 J, in some designs in the range of 100 microJ-100 mJ.

[0047] A wavelength of the irradiation source **120** can be in the range of 400-4,000 nm, in some designs, in the range of 600-1,500 nm. The wavelength of some stimulators **100** can be selected by noting in FIG. 2B, that the muscle fibers of the radial dilators **30** are located in the proximity of the pigmented epithelium of the iris **11**. This fact can be used to selectively target and heat the dilator muscles **30** indirectly. The pigmented epithelium layers may not have essential functions that would be negatively affected by heating, such as undergoing an irrecoverable reactivity change. To build on this, irradiation sources **120** can emit the irradiation **200** with a wavelength close to the wavelength where the absorption of the pigmented epithelium shows a maximum, or is at least greatly enhanced. Such irradiation sources **120** can heat the pigments particularly efficiently, possibly to temperatures 55 C, 60 C, possibly even to 60-65 Celsius. The heated pigmented epithelia can then provide a secondary, or indirect heating to the dilator muscles **30**, located in their immediate proximity, to the medically preferred 50-55 Celsius temperatures.

[0048] FIG. 2B also illustrates that the dilator muscles **30** are in the distal region of the iris **11**, Therefore, irradiation with wavelengths that penetrate the iris tissue more efficiently and to greater depths can be favored to make sure that the dilator muscles **30** are well heated. In several ophthalmologic studies, irradiation with longer wavelengths showed greater penetration into ophthalmic tissues. Therefore, some irradiation sources **120** may emit irradiation **200** with longer wavelengths to penetrate more deeply into the iris, with eventual absorption by the pigmented epithelium, to achieve secondary heating of the dilator muscle fibers **30**. Accordingly, a depth of a treated tissue within the iris can be in some designs in the range of 10 microns-3,000 microns, in some designs, in the range of 500-2,000 microns.

[0049] Some irradiation sources may emit a continuous, or continuous wave (CW) irradiation **200**. Others, such as lasers, or LEDs, may emit pulsed irradiation. A frequency of the pulsed irradiation **200** can be in a range of 1 Hz to 1 MHz, in some designs, in the range of 100 Hz to 100 kHz.

The length of the emitted pulses can vary from 10 femto-seconds to 1 second, in some designs from 1 microsecond to 1 millisecond. The total treatment time can be in the range of 1 sec to 300 sec, in some embodiments in the range of 10 sec to 100 sec. A beam profile of the patterned irradiation **200p** can be a rectangular, a fiat top, a smoothed, a Gaussian, or a Lorentzian profile.

[0050] An inner radius $R_{p(\text{inner})}$ of the pattern **210** can be in the range of 2-10 mm, in some designs in the range of 3-6 mm. An outer radius $R_{p(\text{outer})}$ of the pattern **210** can be in the range of 3-15 mm, in some designs, in the range of 5-10 mm. The pattern **210** can be such that a treated fraction of the iris has an area that is 10-80% of the total area of the iris **11**, in some design, this fraction can in the range of 20-50%.

[0051] In some embodiments, the irradiation delivery system **130** can include a pattern generator, an optical beam shaper, a patterning optics, a beam profiler, or a digitally controlled irradiation optics. Some of these elements can be built mostly from passive optical elements, such as lenses and mirrors, with some system characteristics controlled electronically, such as a telescopic distance between two lenses. In other embodiments, the irradiation delivery system **130** can include optical elements that are actively operated and controlled by electronic or digital circuitry, as described below.

[0052] Some embodiments of the ophthalmic stimulator **100** can be configured to increase a temperature of a treatment region of the iris to a range of 45-60 degrees Celsius. Other embodiments can increase the temperature of the treatment region of the iris to a range of 50-55 degrees Celsius. As discussed in relation to FIGS. 4A-B, treatments with temperatures in these ranges have been demonstrated to impact the responsiveness of smooth muscle tissue temporarily, in a reversible and repeatable manner.

[0053] The actual effect of the heat treatment depends on several factors, since different temperatures and treatment durations can have a multitude of effects on smooth muscle cells and function. On the cellular level, first, a heat treatment can induce biochemical changes and secretions that can affect the functioning of the treated tissue, such as heat shock proteins. Second, it can cause loss of cells through various mechanisms, such as apoptosis, or programmed cell death. Finally, on a much shorter time scale, heat treatment can lead to specific loss of contractility due to denaturation of myosin molecules or inhibition of ion channels.

[0054] On a higher, physiological level, the effect of the heat treatment on the pupil may depend on factors such as dilator muscle fiber orientation, and on opposing, constrictor, muscle action. Finally, the heat treatment can change the physical properties of the muscles in different aspects as well, including shrinking or expanding the length of the muscle strands, making the strands more or less aligned, and changing of the elastic moduli of the muscles, among others.

[0055] For all these reasons, the iris of the individual patients can be analyzed by the ophthalmologist before the treatment with the ophthalmic stimulator **100**. Based on the analysis, the desired medical outcomes can be cross-referenced with the patient data of the individual patients. Subsequently, the treatment region, treatment parameters and specifically the treatment temperatures can be set. As discussed further below, for some medical outcomes heating the radial dilator muscles **30** can be preferable, for others,

heating the circular sphincter muscles **40** can be preferable. The treatment regions can be set according to these medical considerations.

[0056] FIGS. 6A-D illustrate that in some embodiments of the ophthalmic stimulator **100**, the irradiation control system **110** can include an irradiation controller **112**, an imaging system **114** and a user interface **118**. The imaging system **114** can be electronically coupled to the irradiation controller **112**, to relay images, image-related data, and control information. The imaging system **114** can include an image processor **114ip**, whose functions will be described later.

[0057] FIGS. 6A-B illustrate two implementations of the imaging system **114**. In FIG. 6A, an imaging light **220** is reflected out from the optical pathway of the patterned irradiation **200p** by a beam splitter **131** towards the imaging system **114** that is positioned outside the irradiation optical pathway. In FIG. 6B, a small imaging system, such as a small CCD camera **114** can be placed on the distal end of the irradiation delivery system **130**, directly receiving the imaging light **220**. The imaging light **220** can be a reflection of an imaging light, projected on the iris **11** by an imaging light source. In other designs, the imaging light **220** can be simply the ambient light reflected from the iris **11**.

[0058] The imaging system **114** can be any one of the well known ophthalmic imaging systems, including a CCD camera, feeding into a video monitor, any other electronic or digital imaging system, a video microscope, or a surgical microscope.

[0059] The irradiation control system **110** can generate the irradiation control signal by generating an image of the iris **11** of the eye with the imaging system **114** for a user, followed by receiving an image-based input from the user through the user interface **118**, and generating the irradiation control signal to control the irradiation delivery system **130** to deliver the patterned irradiation **200p** in accordance with the received image-based input.

[0060] In a typical example, the patterned irradiation **200p** can impact the iris **11** in a ring pattern **210** with an inner radius $R_{p(\text{inner})}$ and an outer radius $R_{p(\text{outer})}$. In this embodiment, the user of the system, such as ophthalmologist, or an ophthalmic surgeon, can be prompted via the user interface **118** to enter the image-based input, which in this case can be a selection of the inner radius $R_{p(\text{inner})}$ and the outer radius $R_{p(\text{outer})}$ of the ring pattern **210**, based on the surgeon analyzing the image, relayed by the imaging system **114**.

[0061] FIGS. 12D-E illustrate that setting these radii $R_{p(\text{inner})}$ and $R_{p(\text{outer})}$ determines whether the ring pattern **210**, and thus the treatment region, is the region of the radial dilator muscles **30**, or the circular sphincter muscles **40**. Denoting the outer radius of the sphincter muscles with $R(\text{sphincter})$, if the surgeon selects the inner radius $R_{p(\text{inner})}$ of the ring pattern **210** to be greater than $R(\text{sphincter})$: $R_{p(\text{inner})} > R(\text{sphincter})$, then the ring pattern **210** will fall on the radial dilator muscles **30**, and those muscles will receive the heat treatment. Whereas, if the surgeon selects the outer radius $R_{p(\text{outer})}$ of the ring pattern **210** to be smaller than $R(\text{sphincter})$: $R_{p(\text{outer})} < R(\text{sphincter})$, then the ring pattern **210** will fill on the circular sphincter muscles **40**, and the circular sphincter muscles **40** will be treated by the patterned irradiation **200p**. As discussed, an ophthalmologist can select either treatment region based on a prior analysis of the patient's specific data, and the desired medical outcomes.

[0062] In some embodiments, the irradiation control system **110** can include an image processor **114ip** in the imaging system **114**. The image processor **114ip** can be integrated with the imaging system **114**, can be partially integrated, or can be a separate electronic or computational system. In these embodiments, the irradiation control system **110** can generate the irradiation control signal by generating an image of the iris **11** with the imaging system **114** for the image processor **114ip**, receiving an image-based input from the image processor **114ip**, and generating the irradiation control signal to control the irradiation delivery system **130** to deliver the patterned irradiation **200p** in accordance with the received image-based input.

[0063] In a representative embodiment, the patterned irradiation **200p** can impact the iris **11** in a ring pattern **210** with inner and outer radii $R_{p(\text{inner})}$ and $R_{p(\text{outer})}$. The imaging system **114** can image the iris **11**, and relay this image to the image processor **114ip**. In response, the image processor **114ip** can run an image recognition program, possibly including an edge-recognition software, and identify the inner and outer radii of the iris **11**, and the radius $R(\text{sphincter})$ that demarcates the radial dilator muscles **30** from the circular sphincter muscles **40**. Then, the image processor **114ip** can generate the image-based input that sets, or suggests to set, the $R_{p(\text{inner})}$ and $R_{p(\text{outer})}$ radii of the ring pattern **210**. The effect of these choices on the treatment region and the corresponding medical effects have been explained earlier.

[0064] FIG. 12A-C illustrate that in some embodiments of the ophthalmic stimulator **100**, the irradiation control system **110** can include an alignment system **135**.

[0065] FIG. 12A illustrates that in some embodiments the ophthalmic stimulator **100** can include an objective **133**, the last optical element that guides the patterned irradiation **200p** toward the eye **1**. In these embodiments, the alignment system **135** can include a frame, or chin-rest **136**, on which the patient can rest her/his chin to minimize the motion of the eye **1** relative to the stimulator **100**. The alignment system **135** can also include a patient interface **137** that contacts the eye **1** of the patient. Many types of patient interfaces **137** are known in the art and can be used here. FIG. 12A illustrates a patient interface **137**, whose proximal end is attached to the objective **133** of the ophthalmic stimulator **100**, and whose distal end the patient presses her eyes against. The patient interface **137** can ensure a firm coupling, or docking, to the eye by involving a vacuum suction system, or a forceps. The patient interface **137** can be a one-piece or a two-piece patient interface. The distal end of the patient interface **137** can include a contact lens, to ensure a smoother, softer connection to the eye. Such a contact lens also minimizes the optical distortions of the patterned irradiation **200p** as it exits the patient interface **137** and enters the cornea **5** of the eye **1**.

[0066] FIG. 12B illustrates another embodiment of the alignment system **135**, where the patient interface **137** is coupled to the frame **136** instead of the stimulator **100**. Since the frame **136** is rigidly coupled to the ophthalmic stimulator **100**, the optical pathway of the patterned light **200p** is similarly secure from the objective to the eye **1** in this embodiment as well. One of the differences is that there is a distance between the stimulator **100** and the patient interface, **137**, so the patient does not have to lean forward to receive the treatment, and the doctor sees where the patterned light **200p** hits the patient interface **137**. As before,

this patient interface 137 can also be a one-piece and a two-piece patient interface 137.

[0067] The patient interfaces 137 of either FIG. 12A or 12B is preferably aligned and centered with the eye 1 before coupling, or docking them to the eye 1. FIG. 12C illustrates a corresponding aligning, or centering, pattern 138 of the alignment system 135. This centering pattern, or aligning pattern, can include an aligning ring 138a, or an aligning cross-hair 138b, or both. This aligning pattern 138 can be formed in, projected into, or digitally overlaid, the image formed by the imaging system 114, in a position that is concentric with the optical axis of the objective 133. The ophthalmic surgeon, or any other user or operator, can dock the patient interface 137 of the stimulator 100 to the eye with increased precision, with aligning, or centering, the aligning element 138 with the pupil 1 during the docking procedure.

[0068] In a video-monitor-based embodiment, the surgeon can make the centering of the aligning ring 138a on the video image with the edge of the pupil 13 part of the docking. During the docking, the surgeon can instruct the patient to move her/his head and eye around, until the circular edge of the pupil 13 is concentric with the aligning ring 138a. Then the surgeon can complete the docking of the patient interface 137 to the eye 1. Further embodiments of the alignment system 135 will be described later.

[0069] In some designs, the stimulator 100 can include a fixation light 202, and the surgeon can instruct the patient to stare at the fixation light 202 during docking. The patient staring, or fixating at the fixation light 202 can further help centering the patient interface 137 with the pupil 13 during the docking.

[0070] In these embodiments, the irradiation control system 110 can generate the irradiation control signal by processing alignment data with the alignment system 135, and generating the irradiation control signal to control the irradiation delivery system 130 to deliver the patterned irradiation 200p to the iris in a pattern 210 aligned with the pupil 13 of the eye.

[0071] In some embodiments of the ophthalmic stimulator 100, the processing alignment data can include generating an image of the iris 11 with the imaging system 114, and overlaying an alignment pattern 138 on the generated image. The generating the irradiation control signal can include generating a misalignment-warning signal, or generating an alignment-guidance signal, if a misalignment is detected during the processing of the alignment data that is part of the docking. The misalignment-warning signal can alert the operating surgeon to instruct the patient to move his/her head, eye, or both to improve the alignment to help making the docking precise. Also, for stimulator designs where the stimulator 100 or the patient interface 137 itself can be moved or adjusted, the misalignment-warning signal can alert the surgeon for the need to adjust the stimulator 100 or the patient interface 137.

[0072] An example for an adjustable patient interface 137 is a two-piece patient interface 137, where one piece of the patient interface 137 can be attached to the stimulator 100 at its objective 133, the other piece of the patient interface 137 can be coupled to the eye with vacuum-suction, or pressing, and the docking includes the surgeon maneuvering the two pieces of the patient interface 137 to dock to each other.

[0073] FIGS. 6C-D also show a feedback system 116. This system will be described in detail below.

[0074] FIG. 10 illustrates that the irradiation controller 112 can include a number of blocks. These blocks can be implemented as a dedicated processor or circuitry, or can be implemented as a software, code, program, or application, implemented on a computer of the irradiation controller 112, or a combination of hardware and software blocks. In various embodiments, the irradiation controller 112 can include:

[0075] a feedback block 112a, to receive feedback data and to send a feedback signal to a processor 113;

[0076] an imaging block 112b, to receive imaging data and to send an imaging signal to the processor 113;

[0077] an alignment block 112c, to receive alignment data and to send an alignment signal to the processor 113;

[0078] a memory block 112d, to receive patterns for storage and patient data, to store algorithms and codes, and to send stored, patterns, patient data, or executable algorithms to the processor 113;

[0079] a pattern generator block 112e, to receive pattern parameters and to send generated patterns to the processor 113;

[0080] a user interface block 112f, to receive a user input, for example through a user interface 118, that can be patterns, commands, and irradiation parameters, and to send the received patterns, commands and irradiation data as a user input signal to the processor 113.

[0081] Each of these blocks can receive, their input from corresponding hardware blocks, such as sensors, controllers, hardware blocks and user interfaces. For example, the feedback block 112a can be a dedicated circuitry that receives the feedback data from the feedback system 116, as described below. The imaging block 112b can be a software algorithm, implemented on a processor that receives the imaging data from the imaging system 114 that can include a CCD camera, a video monitor, or a surgical microscope.

[0082] In response to signals, received from any of the blocks 112a-f, the processor 113 can send an irradiation control signal to the irradiation source 120, or to the irradiation delivery system 130, or to both.

[0083] In some detail, in embodiments of the ophthalmic stimulator 100 the irradiation control system 110 can include the memory 112d, and the generating the irradiation control signal can include recalling stored data from the memory 112d, representing at least one of an irradiation pattern and patient data, and generating the irradiation control signal to control the irradiation delivery system 130 to deliver the patterned irradiation 200p to the iris 11 in accordance with the recalled stored data.

[0084] In embodiments, the irradiation control system 110 can include a pattern generator; and the generating the irradiation control signal can include generating an electronic representation of the irradiation pattern 210; and generating the irradiation control signal to control the irradiation delivery system 130 to deliver the patterned irradiation 200p with the generated irradiation pattern 210.

[0085] Returning to the medial effects and treatments, embodiments of the ophthalmic stimulator 100 can cause a temporary constriction of the pupil 13 of the eye that includes an at least 5% reduction of a radius of the pupil 13 that lasts less than one hour. In some cases, the reduction of the radius of the pupil can last for a time interval more than one hour and less than one day. In other embodiments, the temporary constriction of the pupil of the eye includes an at

least 5% reduction of the radius of the pupil that lasts for a time interval between one day and one week; or between one week and one month; or between one month and three months; or between three months and one year.

[0086] Each of these time intervals has their own medical and patient advantages. The longer the pupil constriction lasts, the less often the treatment may need to be applied, which can be preferred by patients. Also, the overall paradigm of use of the ophthalmic stimulator 100 depends on the duration of the constriction. Stimulators that constrict a pupil for a month or longer can be deployed in the offices of ophthalmologists, and patients can schedule regular visits for re-constriction treatments on a monthly basis. Stimulators that constrict the pupil for a day or longer could be tabletop systems that the individual patients buy, or lease, and they self-administer the treatment, for example, as part of a daily routine. Finally, stimulators that constrict the pupil for an hour, or for a few hours, can be mobile systems which the patient can carry with themselves and apply the treatment on demand. Obviously, stimulators operated by untrained patients have to have much more robust safety, monitoring and control systems to prevent undesirable medical outcomes. In sum, embodiments that constrict the pupil for different time intervals can offer very different medical outcomes, may be operated by very different personnel, and may need very different safety, monitoring and control systems.

[0087] FIG. 11A illustrates embodiments of a method 300, related for the preceding description, for temporarily constricting a pupil 13 of an eye by an ophthalmic stimulator 100. The method 300 includes the following steps:

[0088] generating 310 an irradiation control signal by an irradiation control system 110; generating 320 an irradiation 200 by an irradiation source 120, coupled to the irradiation control system 110;

[0089] receiving 330 the irradiation 200, and delivering 332 a patterned irradiation 200_p to an iris 11 of the eye with an irradiation delivery system 130; and

[0090] controlling 340 at least one of the irradiation source 120 and the irradiation delivery system 130 by the irradiation control signal of the irradiation control system 110 so that the patterned irradiation is causing a temporary constriction of the pupil of the eye, without causing a permanent constriction of the pupil.

[0091] In embodiments, the generating 320 the irradiation 200 can include generating a flat beam, an electromagnetic irradiation, a LED light, a narrow-band light, a broad-band light, an infrared beam, an incoherent light, a radio-frequency beam, or a sound by the irradiation source 120. Another class of irradiation sources 120 can include a coherent light source, a laser beam, a continuous wave laser beam, or a pulsed laser beam. Marked differences between the preceding incoherent irradiation sources and the just-listed coherent and laser sources will be discussed below.

[0092] The delivering 332 of the patterned irradiation 200_p can include patterning the irradiation 200 by at least one of a pattern generator 112e, an optical beam shaper 132, a patterning optics, a beam profiler, a beam scanner 134, and a digitally controlled irradiation optics.

[0093] In embodiments, the causing the temporary constriction of the pupil can include increasing a temperature of a treatment region of the iris to a range of 45-60 degrees

Celsius. In some embodiments, the temperature of the treatment region of the iris can be raised into a range of 50-55 degrees Celsius.

[0094] FIG. 10 illustrates, that in some embodiments of the method 300, the irradiation control system 110 can include an imaging system 114, in some cases with a corresponding imaging block 112b in the irradiation controller 112, and a user interface 118, in some cases with a corresponding user interface block 112f in the irradiation controller 112. In these embodiments, the generating 310 of the irradiation control signal can include generating an image of the iris 11 of the eye with the imaging system 114 for a user, receiving an image-based input from the user through the user interface 118, and generating the irradiation control signal to control the irradiation delivery system 130 to deliver the patterned irradiation 200_p in accordance with the received input. In embodiments, the patterned irradiation 200_p can impact the iris in a ring pattern 210; and the image-based input can be an inner radius Rp(inner) and an outer radius Rp(outer) of the ring pattern 210, selected by the user.

[0095] In some embodiments of the method 300, the irradiation control system 110 can include an imaging system 114, and an image processor 114ip, in some cases implemented in the imaging block 112b of the irradiation controller 112. The generating 310 of the irradiation control signal can include generating an image of the iris of the eye with the imaging system 114 for the image processor 114ip; processing the image of the iris and generating an image-based input by the image processor 114ip; receiving the image-based input from the image processor 114ip; and generating 310 the irradiation control signal to control the irradiation delivery system 130 to deliver the patterned irradiation 200_p in accordance with the received image-based input. In some designs, the patterned irradiation 200_p can impact the iris 11 in a ring pattern 210; and the image-based input can be an inner radius Rp(inner) and an outer radius Rp(outer) of the ring pattern.

[0096] In some embodiments of the method 300, the irradiation control system 110 can include an alignment system 135, in some cases with its alignment block 112c in the irradiation controller 112; and the generating 310 of the irradiation control signal can include processing alignment data with the alignment system 135, and generating the irradiation control signal to control the irradiation delivery system 130 to deliver the patterned irradiation 200_p to the iris in a pattern 210 aligned with the pupil 13 of the iris 11.

[0097] In some embodiments of the method 300, the processing alignment data can include generating an image of the iris with an imaging system 114 and overlaying an alignment pattern 138 on the image, in some cases with the alignment block 112c, or with the image processor 114ip; and the generating 310 the irradiation control signal can include generating a misalignment warning signal, or generating an alignment-guidance signal.

[0098] In some embodiments, the irradiation control system 110 can include a memory block 112d; and the generating the irradiation control signal 310 can include recalling stored data from the memory block 112d, representing at least one of an irradiation pattern 210 and patient data; and generating 310 the irradiation control signal to control the irradiation delivery system 130 to deliver the patterned irradiation 200_p to the iris 11 in accordance with the recalled stored data. In some designs, the irradiation control system

can include the pattern generator **112e**, and the generating **310** of the irradiation control signal can include generating the irradiation pattern **210**; and generating the irradiation control signal to control the irradiation delivery system **130** to deliver the patterned irradiation **200p** with the generated irradiation pattern **210**.

[0099] Some embodiments of the method **300** can include acquiring and analyzing patient data; selecting a treatment region based on the analyzing of the patient data; and delivering the patterned irradiation **200p** to the selected treatment region. A notable embodiment of this step is the ophthalmologist analyzing patient data and deciding whether the treatment radiation shall be applied to the radial dilator muscles **30**, or to the circular sphincter muscles **40**. This analysis and decision can involve selecting the appropriate treatment parameters among the large number of treatment parameters described previously.

[0100] In some cases, the selecting the treatment region can include selecting a ring pattern **210r** with an inner radius $R_p(\text{inner})$ larger than $R(\text{sphincter})$, a radius of a region of the circular sphincter muscles **40**.

[0101] In some cases, the selecting the treatment region can include selecting a ring pattern **210r** with an outer radius $R_p(\text{outer})$ smaller than $R(\text{sphincter})$, the radius of a region of the circular sphincter muscles **40**.

[0102] Some embodiments of the method **300** can include controlling the irradiation source **120**, or the irradiation delivery system **130**, or both, so that the patterned irradiation **200p** is causing a temporary constriction of the pupil of the eye that includes an at least 5% reduction of a radius of the pupil that lasts less than one hour.

[0103] In some cases, the temporary constriction of the pupil can last between one hour and one day. In some cases, the temporary constriction of the pupil can last between one day and one week; in some cases between one week and one month; in some cases between one month and three months; and in some cases between three months and one year. The medical, patient, implementation, and safety differences between embodiments involving temporary constrictions of different duration have been discussed earlier.

[0104] The ophthalmic stimulators **100** described up to now shared a common trait: they caused a temporary constriction of the pupil.

[0105] FIG. 5B illustrates a distinct class of permanent ophthalmic stimulators **100'** that can cause a long-term, or even a permanent constriction of the pupil. These ophthalmic stimulators **100'** share some of the major engineering elements with the temporary constriction stimulators **100**, but have different medical modes of action, different irradiation sources, and stronger safety systems, among others.

[0106] In some, embodiments, an ophthalmic stimulator **100'** for constricting a pupil of an eye can include an irradiation control system **110'**, to generate an irradiation control signal; an irradiation source **120'**, coupled to the irradiation control system **110'**, to generate an irradiation **200'**; and an irradiation delivery system **130'**, coupled to the irradiation control system **110'**, to receive the irradiation **200'** from the irradiation source **120'**, and to deliver a patterned irradiation **200p'** to the iris **11** of the eye **1**; wherein the irradiation control system **110'** controls the irradiation source **120'**, or the irradiation delivery system **130'**, or both, with the irradiation control signal so that the patterned irradiation **200p'** causes a long-term constriction of the pupil of the eye.

[0107] In a class of the ophthalmic stimulator **100'**, the irradiation source **120'** can include an incoherent light source, such as a lamp, a LED, an infrared light source, a radiofrequency source, an electromagnetic source and a sound source. In another class, the irradiation source **120'** can include a coherent light source, such as laser, a pulsed laser and a continuous wave laser. There are substantial differences between irradiation sources that employ incoherent light sources and those that employ coherent light sources, as discussed above.

[0108] In some embodiments, the irradiation delivery system **130'** can include an optical beam shaper and a patterning optics,

[0109] In some embodiments, the ophthalmic stimulator **100'** can be configured to increase a temperature of a treatment region of the iris to a range of 50-80 degrees Celsius. In some embodiments, the ophthalmic stimulator **100'** can be configured to increase a temperature of the treatment region of the iris to a range of 55-70 degrees Celsius.

[0110] Sonic embodiments of the ophthalmic stimulator **100'** can cause a long-term constriction of the pupil that lasts longer than a year. In some cases, the ophthalmic stimulator **100'** can be designed to cause an irreversible change in the iris of the eye. This long-term, or permanent, change can be a change of the length, or spatial extent, of the treated muscle tissue. In other cases, it can be a reduced, or enhanced, elasticity, or flexibility. In some cases, it can be an altered stiffness. In some cases, it can be an altered reactivity to stimuli.

[0111] The ophthalmic stimulator **100'** achieves the long-term reduction of constriction of the pupil by applying the irradiation **200'** with treatment parameters critically different from the ones used by the temporary stimulator **100**. The critical difference can be one of many factors that cause permanent, or long-term constriction of the pupil, including the followings. Beams with wavelength short enough to cause permanent change. Beams with intensity per area high enough to cause long-term change. Beams with total deposited energy high enough to cause permanent change. Beams with treatment times long enough to cause permanent change. Beams with beam pulses long enough, and frequencies high enough to cause permanent change. Which specific parameters are sufficient to make the change permanent is patient specific and is selected by the surgeon.

[0112] In some embodiments, the irradiation control system **110'** can include an imaging system **114'** and a user interface **118'**. In these embodiments, the irradiation control system **110'** can, generate the irradiation control signal by generating an image of the iris of the eye with the imaging system **114'** for a user, receiving an image-based input from the user through the user interface **118'**, and generating the irradiation control signal to control the irradiation delivery system **130'** to deliver the patterned irradiation **200p'** in accordance with the received input.

[0113] Some of the engineering details of the permanent ophthalmic stimulator **100'** are analogous to that of the temporary ophthalmic stimulator **100**. To contain the length of this document, some of these details of the stimulator **100'** will not be provided with their own figures, but the corresponding figures in the description of the stimulator **100** will be referenced, with the understanding that those need to be modified to cause a long term, not temporary constriction of the pupil.

[0114] In some embodiments of the ophthalmic stimulator 100', the irradiation control system 110' can include an alignment system 135'; and the irradiation control system 110' can generate the irradiation control signal by processing alignment data with the alignment system 135', and generating the irradiation control signal to control the irradiation delivery system 130' to deliver the patterned irradiation 200p' to the iris in a pattern 210, aligned with a pupil 13 of the iris 11.

[0115] FIG. 11B illustrates a related method 300' for causing a long-term constriction of a pupil of an eye by the ophthalmic stimulator 100'. The method 300' can include the following steps:

[0116] generating 310' an irradiation control signal by an irradiation control system 110';

[0117] generating 320' an irradiation by an irradiation source 120', coupled to the irradiation control system 110';

[0118] receiving 330' the irradiation and delivering 332' a patterned irradiation to an iris of the eye with an irradiation delivery system 130'; and

[0119] controlling 340' at least one of the irradiation source 120' and the irradiation delivery system 130' by the irradiation control signal of the irradiation control system 110' so that the patterned irradiation causes a long-term constriction of the pupil of the eye.

[0120] In the method 300', the causing the long-term constriction of the pupil can include increasing a temperature of a treatment region of the iris to a range of 50-80 degrees Celsius. In some cases, the method 300' can include increasing a temperature of the treatment region of the iris to a range of 55-70 degrees Celsius. While these ranges have some overlap with temperature ranges described in relation to the temporary stimulator 100, for a particular patient the temperature range where the constriction is temporary can be quite well separated from the temperature range, where the constriction is permanent. For example, for a particular patient, temperatures in the range of 50-55 C may constrict the pupil for a day or less; temperatures in the 55-60 C range may cause the pupil to constrict for a time between a week and a month, temperatures in the 60-65 C range can cause the pupil to constrict for a time between a month and a year, and temperatures in the 65-70 C range may cause the pupil to constrict for a time longer than a year. These long-term changes can very well be associated with an irreversible change in the iris of the eye.

[0121] As before, in some embodiments of the method 300' the irradiation control system 110' can include an imaging system 114 and a user interface 118; and the generating the irradiation control signal can include generating an image of the iris of the eye with the imaging system 114 for a user, receiving an image-based input from the user through the user interface 118, and generating the irradiation control signal to control the irradiation delivery system 130' to deliver the patterned irradiation 200p' in accordance with the received input.

[0122] In some embodiments of the method 300', the irradiation control system 110' can include an alignment system 135; and the generating the irradiation control signal can include processing alignment data with the alignment system 135, and generating the irradiation control signal to control the irradiation delivery system 130' to deliver the patterned irradiation 200p' to the iris in a pattern 210 aligned with a pupil of the iris.

[0123] As discussed, the ophthalmologist operating the stimulator 100' can analyze several factors when practicing the method 300'. The analysis can include the determination what treatment parameters to use to achieve a long-term or permanent constriction change, to go beyond the previously described temporal changes. The analysis can also be focused at which treatment regions to irradiate. As discussed before, some vision-improvement goals can be better achieved by heat-treating the radial dilator muscles 30, others by heat-treating the circular sphincter muscles 40.

[0124] Both of these analyses can involve acquiring and analyzing patient data in a typical example, a patient may have used the temporary ophthalmic stimulator 100 by practicing the method 300 repeatedly and for an extended period, and may have grown comfortable with its effect to the degree that she/he decided to make the constriction of the pupil permanent. During these preceding temporary treatments, the irradiation controller 110 of the stimulator 100, or its operator may have acquired and collected a substantial amount of data about the particular patient. An ophthalmologist, who is planning administering a higher energy irradiation by practicing the method 300' with a permanent ophthalmic stimulator 100' to permanently change the constriction of the pupil, may evaluate and analyze the data that was collected during the previous, repeated temporary constrictions of the pupil of this particular patient. This analysis can be followed by selecting a treatment region based on the analyzing of the patient data; and delivering the patterned irradiation 200p' to the selected treatment region to cause the long-term constriction of the pupil.

[0125] FIG. 7A illustrates that some embodiments of the ophthalmic stimulator 100 may include an irradiation control system 110, to generate an irradiation control signal; a light source 120, coupled to the irradiation control system 110, to generate a light beam 200; and a beam-shaping optics 132, coupled to the irradiation control system 110, to receive the light beam 200 from the light source 120, and to deliver a light ring 200r to an iris 11 of the eye in a ring pattern 210r. In embodiments, the irradiation control system 110 can control the light source 120, or the beam-shaping optics 132, or both, with the irradiation control signal so that the light ring 200r causes a temporary constriction of the pupil of the eye, without causing a permanent constriction of the pupil. The beam-shaping optics can also include an objective 133, to direct the light ring 200r towards the iris of the eye, to provide additional control.

[0126] Embodiments of the here-described ophthalmic stimulator 100 can be analogous, or equivalent to the embodiments described in relation to the stimulator 100 in relation to FIGS. 5A-B and 6A-D. In particular, the embodiments of the irradiation source 120 can also serve as the light source 120 here. For example, the light source can be an infrared light source. Also, the beam-shaping optics 132 can be an embodiment of the irradiation delivery system 130.

[0127] FIG. 7B illustrates that the beam-shaping optics 132 can include a proximal axicon lens 140, positioned with its base-plane oriented toward the light source 120, to transform the received light beam 200 into the light ring 200r.

[0128] Here it is recalled that an axicon lens is a glass cone with a circle as its base. An axicon lens can be also visualized as an isosceles triangle, rotated around its axis of symmetry. Direct ray tracing establishes that axicon lenses transform a regular, full light beam into a light ring 200r;

Generating the light ring **200r** “passively”, without any scanners, or other digitally controlled active optics with moving parts, makes an axicon lens a very useful, simple, and reliable implementation of the beam-shaping optics **132** for the purposes of the stimulator **100**.

[0129] However, it is also noted that the radius $r(\text{ring})$ of the light ring **200r** increases with the distance $d(\text{target})$ from the axicon lens **140**. Therefore, if the patient moves her/his head along the optical axis, doing so changes the radius $r(\text{ring})$ of the light ring **200r** and can have undesirable medical effect.

[0130] FIG. 7C illustrates an embodiment of the beam-shaping optics **132** that resolves this problem. This embodiment includes the proximal axicon lens **140-1**, with its base-plane oriented towards the light source **120**. It further includes a second, distal, “complementary” collimating axicon lens **140-2**, that is co-axial with the proximal axicon lens **140-1**, positioned with its cone-tip oriented toward a cone-tip of the proximal axicon lens **140-1**, to collimate the light ring with the increasing radius into a light ring with a constant radius, independent of the distance $d(\text{target})$.

[0131] Embodiments with such a complementary axicon lens pair **140-1** and **140-2** can further include a lens position actuator **141**, to adjust an axicon distance $d(\text{axicon})$ between the proximal axicon lens **140-1** and the distal axicon lens **140-2**. Changing the axicon distance $d(\text{axicon})$ can be used to adjust the radius $r(\text{ring})$ of the light ring **210** as part of the setting of the overall ring pattern **210** by the ophthalmic surgeon in FIGS. 12D-E.

[0132] Additional optical solutions may be needed to tune $R_p(\text{inner})$ independently from $R_p(\text{outer})$, to tune the radius of the ring independently from its width. Examples of such solutions include (a) a beam blocker to block out part of the light ring; (b) a deformable axicon lens **140**, capable of changing the angle of the cone of the axicon lens; and (c) a deformable mirror, in some cases a deformable conical mirror.

[0133] An important aspect of ophthalmic irradiation systems is to ensure that the patient’s eye is aligned with the optical axis of the irradiation system. Previously, various alignment systems **135** have been already described. A particularly useful element of such alignment systems **135** can be a fixation light **202**, as mentioned. The surgeon may instruct the patient to stare, or fixate, on a centrally positioned fixation light. Such fixation lights **202** can be provided by a small bright LED, positioned centrally, projected into, or superimposed into the optical pathway.

[0134] FIG. 7D shows that the beam-shaping optics **132** that uses an axicon lens **140** offers a particularly simple implementation of the fixation light **202**. In some embodiments, the tip of the cone of the axicon lens **140** may be flattened. Such flattened tip axicon lenses **140** do not redirect or refract the small central portion of the incoming light **200**, so that they propagate centrally and thus can act as the fixation light **202**. Such embodiments are attractive because the fixation light **202** is naturally centered with the beam-shaping optics **132**, without the need to introduce any additional structures to hold the fixation light in place that can at the same time block part of the light **200**, and without the need of centering the fixation light **202** by a finely adjustable system.

[0135] In the case when the treatment light **200** is an infrared light, the flattened tip can be covered by a luminescent material, a phosphor, an upconverting material, a

higher harmonic generating material, a multi-photon induced fluorescence material, or any optical material or structure that converts the infrared light **200** into a visible light, needed as a fixation light **202**.

[0136] FIG. 7E illustrates an embodiment of the beam-shaping optics **132**. The incoming light **200** can be guided through a pair of beam-expanding lenses: a diverging, lens **142**, followed by a collimating lens **143**. This **142-143** lens combination can expand the radius of the incoming beam **200** to the $R_p(\text{outer})$ outer radius, set or desired by the ophthalmic surgeon. The beam radius can be adjusted by adjusting the distance of the diverging lens **142** from the collimating lens **143** by an actuator. Next, the expanded beam can be directed at an adjustable beam stop **144** that can block out a central portion of the expanded beam so that the transmitted beam has an inner radius equaling $R_p(\text{inner})$ as set by the surgeon. The radius of the adjustable beam stop **144** can be adjusted by a number of known mechanical designs. Further, since the stopped beam carries an energy with it that can undesirably heat the beam-shaping optics **132**, a heat sink **145** can be employed, configured to absorb, or guide away the energy of the stopped beam. Many heat sinks are known, such as metallic ribs, and air-cooled systems. It is also possible to reflect the stopped beam out of the beam-shaping optics **132** and absorb it or release it peripherally. These solutions reduce the need for heat management greatly.

[0137] FIG. 7F illustrates another embodiment of the beam-shaping optic **132**. This embodiment **132** can be configured to generate a light beam directly with a ring shape, without the need of an optics that would transform the generated light. In a typical embodiment, the light source **200** can include a ring of LEDs **146-1**, **146-2**, . . . , **146-N**, collectively referenced as **146-i**, to generate light beamlets: and a ring-shaped diffuser **147**, to transform the light beamlets into a light beam with a well-distributed intensity profile to form the light ring **200r**. In some embodiments, there can be more than one ring of LEDs **146-i**. Activating a different number of LED rings can be one way to adjust the radius of the light ring **200r**. (Throughout this document, elements “x-1, x-2, x-N” will be sometimes collectively referenced as “x-i”, for brevity.)

[0138] Finally, the embodiments of FIGS. 7B-F can be combined. One such combination was already mentioned. The embodiment based on the axicon-lens **140**, or **140-1/140-2**, may need additional optical elements to adjust the inner and outer radii $R_p(\text{inner})$ and $R_p(\text{outer})$ independently. In some cases, the beam stop **144** can be used to adjust the inner radius $R_p(\text{inner})$ of the light ring **200r** that was generated by the axicon lens **140**.

[0139] FIG. 11C illustrates a method **302** for temporarily constricting a pupil of an eye by an ophthalmic stimulator **100**. The method **302** can include the following steps:

[0140] generating **302a** an irradiation control signal by an irradiation control system **110**;

[0141] generating **302b** a light beam **200** by a light source **120**, coupled to the irradiation control system **110**;

[0142] receiving **302c** the light beam **200**, and delivering **302d** a light ring **200r** to an iris of the eye with a beam-shaping optics **132**; and

[0143] controlling **302e** at least one of the light source **120** and the beam-shaping optics **132** by the irradiation control signal of the irradiation control system **110** so

that the light ring **200r** is causing a temporary constriction of the pupil of the eye, without causing a permanent constriction of the pupil.

[0144] In some embodiments of the method **302**, the delivering **302d** the light ring **200r** can include transforming the received light beam **200** into the light ring **200r** by a proximal axicon lens **140**, positioned with its base-plane oriented toward the light source **120**, wherein the light ring **200r** has an increasing radius $r(\text{ring})$ with increasing distance $d(\text{target})$ from the axicon lens **140**.

[0145] In some cases, the delivering **302d** the light ring **200r** can include collimating the light ring with the increasing radius into a light ring **200r** with a constant radius by a distal collimating axicon lens **140-2**, co-axial with the proximal axicon lens **140-1**, positioned with its cone-tip oriented toward a cone-tip of the proximal axicon lens **140-1**. In these embodiments, the delivering the light ring can include adjusting an axicon distance $d(\text{axicon})$ between the proximal axicon lens **140-1** and the distal axicon lens **140-2** by a lens position actuator **141**, thereby adjusting the radius of the light ring $r(\text{ring})$.

[0146] The method **302** can also include generating a fixation light **202** by selectively transmitting a small fraction of the received light beam **200** by a flattened cone-tip of the proximal axicon lens **140-1**. In embodiments where the light is an infrared light, the small, flattened tip of the axicon lens **140-1** can be covered by an optical material that can transform the infrared light into a visible light.

[0147] In some embodiments of the method **302**, the delivering **302d** the light ring can include utilizing a beam stop **144** to generate the light ring **200r** by blocking a central portion of the received light beam **200**.

[0148] Finally, in some embodiments of the method **302**, the generating **302b** a light beam can include generating the light beam with a ring shape by the light source including a ring of LEDs **146-i**.

[0149] FIG. **8A** illustrates that embodiments of the ophthalmic stimulator **100** for temporarily constricting a pupil of an eye can include a digital beam controller **110**, to generate a digital beam-control signal; a light source **120**, coupled to the digital beam controller **110**, to generate a light beam **200**; and a digitally controlled beam modulator **134**, for example a beam scanner **134**, to receive the digital beam-control signal from the digital beam controller **110**, to receive the light beam from the light source **120**, and to modulate the received light beam into a modulated light, or modulated light **200m**, delivered to an iris of the eye. In embodiments, the digital beam controller **110** can control the light source **120**, the digitally controlled beam modulator **134**, or both, with the digital beam-control signal so that the modulated light **200m** causes a temporary constriction of the pupil of the eye, without causing a permanent constriction of the pupil.

[0150] As before, embodiments of the here-described ophthalmic stimulator **100** can be analogous, or equivalent to the embodiments described in relation to the ophthalmic stimulator **100** in relation to FIGS. **5A-B**, **6A-D**, and **7A-F**. In particular, the embodiments of the irradiation control system **110** can be analogous, or equivalent, to the embodiments of the digital beam controller **110**, the irradiation source **120** can also serve as the light source **120** here, and the digitally controlled beam controller **134** can be an embodiment of the irradiation delivery system **130**.

[0151] In what follows, numerous examples of the digitally controlled beam modulator **134** will be described. To emphasize that all these are embodiments of the same block, they are all labeled with **134** or as a variant of label **134**.

[0152] For example, FIG. **8A** illustrates a beam scanner **134** as an embodiment of the digitally controlled beam modulator **134**, to scan the received light beam **200** according to a pattern **210** on the iris. Embodiments described in relation to FIGS. **8A-B**, and FIGS. **9A-E** can be different from the embodiments described in relation to FIGS. **7A-F** in that the latter embodiments utilize dominantly “passive” optical elements, such as lenses and mirrors, and do not need elaborate digital control signals and moving parts, with the possible exception of the lens position actuator **141**. Also, the systems of FIGS. **7A-F** typically irradiate the pattern **210** simultaneously.

[0153] In contrast, the digitally controlled embodiments of FIGS. **8A-B**, and FIGS. **9A-E** can involve active elements, where extensive digital control signals move or adjust a number of active optical elements. These embodiments typically irradiate the iris on a point-by-point basis, with the help of various types of scanners and optical arrays. As such, these digitally controlled embodiments can offer higher precision and control, at the same time, they can be more complex, raising issues of reliability, maintenance and costs, and the irradiation treatment can take longer. Also, the points of the pattern **210** are often irradiated sequentially, instead of simultaneously.

[0154] FIG. **8B** illustrates one embodiment of the digitally controlled beam modulator **134** in a laser-based ophthalmic stimulator **100**. The light source **120** can be a laser source **120L**, emitting a laser beam **200L**. The digitally controlled beam modulator **134** can be an X-Y scanner **134L**, to scan the received laser beam **200L** as a scanned laser beam **200sL** according to a pattern on the iris. A large number of laser scanners are known that can scan the scanned laser beam **200sL** with a wide variety of complex patterns **210**.

[0155] FIG. **9A** illustrates the first of a set of reflection mode beam modulators **134r**. While the scanner embodiments in FIGS. **8A-B** irradiate the iris in a pattern **210** sequentially, the embodiments of FIGS. **9A-E** can irradiate the pattern **210** either sequentially, or simultaneously. The embodiment of FIG. **9A** includes a reflective LCD array **150** with an addressable array of LCD pixels **152**. Switching the LCD pixels **152** on-off can control how much of an incoming light the LCD array reflects from through the LCD pixels.

[0156] FIG. **9B** illustrates another embodiment of the reflection-mode beam modulator **134r** that includes a deformable reflector **160**, with a substrate **162**; a mechanical actuator array **164**, positioned on the substrate **162**; and a deformable mirror **166**, positioned to be deformable by the mechanical actuator array **164** according to the digital beam-control signal.

[0157] FIG. **9C** illustrates yet another embodiment of a reflection-mode beam modulator **134r**. This is an acousto-optical modulator **170** that includes a set of acoustic piezo transducers **172**, to deform a deformable reflector **174**, according to the beam-control signal. This embodiment has similarities to the previous one in FIG. **9B**. One of the differences is that the deformation is performed not by an array that can be controlled point-by-point, but in a global manner, where the transducers are operated to form patterns across the entire deformable reflector **174** simultaneously.

[0158] FIG. 9D illustrates yet another embodiment of a reflection-mode beam modulator 134*r*. This is a digital mirror device 180 that includes a substrate 182; an array of mechanical actuators 184-*i*, positioned on the substrate 182; and an array of rotatable mirrors 186-*i*, where the rotatable mirrors 186-*i* are rotatable individually by the actuators 184-*i* according to the beam-control signal. Such digital mirror arrays are well known in digital projectors, for example.

[0159] FIG. 9E illustrates a different, transmission-mode beam modulator 134*t*. This embodiment can include an addressable pixel array 190 of variable transparency pixels 192-*i*. This embodiment 190 has design aspects analogous to the embodiment 150 in FIG. 9A, as it also builds on the principle of individual pixels changing their optical (reflective or transmissive) properties under electric control, thereby modulating the beam on a pixel-by-pixel basis. As indicated earlier, the irradiation can be either sequential or in parallel, the latter type embodiments requiring much less moving parts and allowing shorter irradiation times.

[0160] FIGS. 17A-D illustrate various patterns 210 the digitally controlled ophthalmic stimulators 100 can irradiate on the iris with the modulated beam 200*m*. In embodiments, illustrated in FIG. 17A, the digitally controlled beam modulator 134 can be controlled by the beam controller 110 to modulate the received light beam 200 into a modulated light 200*m*, so that it irradiates a pattern 210 that is a ring, or multiple rings. FIG. 17B illustrates a pattern 210 that is a segmented ring. FIG. 17C illustrates a pattern 210 that includes radial spokes. Finally, FIG. 17D illustrates a pattern that is a combination of ring segments and spokes.

[0161] FIG. 11D illustrates a method 304 that is related to operating the digitally controlled ophthalmic stimulators 100. The method 304 can include the following steps:

[0162] generating 304*a* a digital beam-control signal by a digital beam controller 110;

[0163] generating 304*b* a light beam 200 by a light source 120, coupled to the digital beam controller 110;

[0164] receiving 304*c* the light beam 200, modulating 304*d* the light beam 200 into a modulated light 200*m*, and delivering 304*e* the modulated light 200*m* to an iris of the eye, with a digitally controlled beam modulator 134; and

[0165] controlling 304*f* the light source 110, the digitally controlled beam modulator 134, or both, by the digital beam-control signal of the digital beam controller 110 so that the modulated light 200*m* is causing a temporary constriction of the pupil of the eye, without causing a permanent constriction of the pupil.

[0166] In embodiments, the modulating 304*d* can include scanning the received light beam on the iris according to a pattern by a beam scanner 134. In other embodiments, the modulating 304*d* can include modulating the light by a reflection-mode beam modulator 134*r*. The reflection-mode beam modulator 134*r* can be a reflective LCD array 150, with an addressable array of LCD pixels, a deformable reflector 160, an acousto-optical modulator 170, and a digital mirror device 180. In some embodiments of the method, the modulating 304*d* can include modulating the light by a transmission-mode beam modulator 134*t*.

[0167] Finally, the modulating 304*d* can include modulating the received light beam into the modulated light 200*m* with the pattern being one of a ring, multiple rings, a

segmented ring, a pattern of radial spokes, and a combination of ring segments and spokes.

[0168] FIG. 15 illustrates other embodiments of an ophthalmic stimulator 100 for temporarily constricting a pupil of an eye that includes an irradiation control system 110, having a feedback system, to generate an irradiation control signal using a feedback of the feedback system; an irradiation source 120, coupled to the irradiation control system 110, to generate an irradiation; and an irradiation delivery system 130, coupled to the irradiation control system 110, to receive the irradiation 200 from the irradiation source 120, and to direct a patterned irradiation 200*p* in a pattern to a treatment region of an iris of the eye, guided by the feedback-based irradiation control signal; wherein the irradiation control system 110 controls at least one of the irradiation source 120 and the irradiation delivery system 130 with the feedback-based irradiation control signal so that the patterned irradiation 200*p* causes a temporary constriction of the pupil, without causing a permanent constriction of the pupil. As before, the here-described embodiments can be analogous to the ones described in relation to FIGS. 5A-B, FIGS. 6A-D, FIGS. 7A-F, and FIGS. 8A-B, and analogously labeled elements can serve analogous functions.

[0169] In what follows, various embodiments and blocks of the feedback system 116 will be described. These embodiments and blocks typically include a hardware block, such as an imaging system, or a temperature sensor. They are coupled to the irradiation controller 112, which processes their feedback and generates irradiation control signals, to be transmitted to the irradiation source 120 and to the irradiation delivery system 130. As discussed in relation to FIG. 10, the irradiation controller 112 can include corresponding blocks that are dedicated to receive the feedback. For example, the irradiation controller 112 can include the dedicated feedback block 112*a* to receive the feedback from an embodiment of the feedback system 116. These receiving blocks can be implemented in hardware, such as an application specific integrated circuit ASIC; or they can be implemented in a software form, such as a piece of code or application, implemented in the processor 113 of the irradiation controller 112; or in a shared processor, or input/output controller. In yet other embodiments, the feedback can be coupled straight into the central processor 113, whose code can process the feedback directly. A particularly simple implementation can be a simple “stop” feedback signal, triggered by a security concern, which can be directly executed by the processor by shutting down the irradiation source 120 with a control signal, without the need of any intermediate processing.

[0170] In some embodiments, the feedback system 116 can include at least one of a pupillometer 116*a* and an imaging system 114, to sense a diameter of the pupil, and to generate a feedback according to the sensed pupil diameter. As discussed just now, this feedback can be received and processed either by a dedicated feedback block 112*a* that is implemented inside the irradiation controller 112, or can be received by the processor 113 of the irradiation controller 112 itself. In some embodiments, the pupillometer 116*a* can be coupled to the irradiation controller 112 directly, in others, through a user interface 118-1*a*. Similarly, the imaging system 114 can be coupled to the irradiation controller 112 directly, or through a user interface 118-2.

[0171] FIGS. 16A-E illustrate methods, or processes, 510-550 that operate in relation to the embodiments 116*a-f* of the

feedback system **116**. In general, the methods, or processes, **510-550** can include the following steps:

[0172] generating a feedback-based irradiation control signal by an irradiation control system **110**, using a feedback of a feedback system of the irradiation control system;

[0173] generating an irradiation **200** by an irradiation source **120**, coupled to the irradiation control system;

[0174] receiving the irradiation **200** and directing a patterned irradiation **200p** to a treatment region of an iris of the eye with an irradiation delivery system **130**, guided by the feedback-based irradiation-control signal; and

[0175] controlling at least one of the irradiation source **120** and the irradiation delivery system **130** with the feedback-based irradiation control signal of the irradiation control system **110** so that the patterned irradiation **200p** causes a temporary constriction of the pupil, without causing a permanent constriction of the pupil.

[0176] The description continues with details of the processes, or methods, **510-550**. FIG. 16A illustrates that in a representative case, the feedback can be generated through the following sequence, method, or process **510**. A short time after starting to apply the patterned irradiation **200p** to the iris **11** according to the pattern **210**, in step **511**, the pupillometer **116a**, or the imaging system **114**, can sense that “Pupil radius is large relative to a reference or target”, or “Target radius not reached”. This can be followed by a step **512**, generating the feedback, or feedback signal: “Carry on irradiation”, as indicated by the eye and steps on the left side of FIG. 16A. Here and in what follows, each “step x of generating feedback signal” may also be referred to with the shorter form of “feedback signal x”, for brevity. Also, the feedback signal can include not only the command to continue or to stop the irradiation, but it can also include the sensed information as well, in the present example, the step **512** of generating a feedback signal can include sending the feedback signal “Target radius not reached. Carry on.”

[0177] With the passing of time, the irradiation increases the temperature of a portion of the iris **11**, as indicated by the denser dot-filling of the pattern **210** on the right. The increased temperature induces the constriction of the pupil **13**, as indicated by the eye **1** having a smaller pupil **13** on the right of FIG. 16A. In step **513**, the pupillometer **116a**, or the imaging system **114**, can sense that “Pupil radius is sufficiently close to the reference”, or “Target pupil radius sensed”. This can be followed by the generation of the feedback in step **514**: “Power down irradiation”, or “Target radius reached, Power down”. This feedback, or feedback signal **514** can be transmitted by the feedback system **116** to the irradiation controller **112**. In response, the irradiation control system **110** can send a corresponding feedback-based irradiation control signal to the irradiation source **120** to power down. The top graph of FIG. 16A illustrates that the feedback-induced irradiation control signal **514** causes the powering down of the irradiation after the receiving of the feedback signal **514**.

[0178] It is mentioned here that pupillometers reached a high level of sophistication and can provide a variety of useful, actionable information. For a review of the field, see Olson D, Stutzman S, Saju C, Wilson M, Zhao, W, Aiyagari V. Interrater of Papillary Assessments, Neurocrit Care, Published online: 17 Sep. 2015. These pupillometers can assess pupil size, and shape with very high accuracy and repro-

ducibility. In addition, such devices can measure parameters such as onset and peak constriction, constriction and dilation velocity, and latency using various light stimuli, both before and after treatment to assess effects that may not be apparent simply based on pupil diameter.

[0179] FIG. 15 illustrates that in some embodiments, the feedback system **116** can include a pupillometer **116a**, and at least one of an infrared sensor or camera **116b** to sense a temperature of the treatment region, and to generate a feedback according to the sensed temperature. As before, the infrared camera **116b** can be coupled to the irradiation controller **112** directly, or via a user interface **118-1b**.

[0180] FIG. 16B illustrates the corresponding process **520**, or method **520**, or sequence of operation of this infrared sensor/camera **116b**. At an early time during the irradiation, in a step **521**, the infrared sensor/camera **116b** can sense “Temperature low relative to a reference”, or simply “Low temperature”. In a typical case, a temperature T sensed to be less than 45 C can be classified as “low temperature”. This can prompt generating the feedback in step **522**: “Carry on irradiation”. Visibly this feedback leads to the maintaining the power of the irradiation, as indicated by the graph on top of FIG. 16B.

[0181] With the progression of the irradiation time, the target region, irradiated according to the pattern **210**, starts warming up. This is indicated by the dotting of the pattern **210** getting denser. After some time, in step **523**, the infrared (thermal) sensor/camera **116b** can sense “a medium temperature relative to the reference”, or simply “medium temperature”. In a typical example, this can be a temperature in the 45 C-55 C range. In response, a feedback signal can be generated in step **524**, sent from the feedback system **116** to the irradiation controller **112**: “Start power down the irradiation”, or “Medium temperature. Power down”. As indicated, the irradiation control system **110** can generate a feedback-based irradiation control signal to the irradiation source **120**, which in response can start powering down the power of the irradiation gradually, as indicated by the dashed line in the top graph.

[0182] In some embodiments, the settings and thresholds can be chosen differently. In such cases, the IR camera **116b** can wait until it senses a “high temperature relative to the reference” in step **525**, such as the IR sensor/camera **116b** senses the temperature T that exceeds 55 C. Such a sensing by the IR sensor/camera **116b** can prompt the generation of the feedback “Stop the irradiation” in step **526**, to be sent to the irradiation controller **112**. Analogously to earlier steps of the process, the irradiation control system **110** can generate a feedback-based irradiation control signal for the irradiation source **120** to discontinue the irradiation with a hard stop, as indicated by the solid line in the top graph of FIG. 16B.

[0183] One such scenario can be associated with an irregular, or unexpected progress of the irradiation, when, for whatever reason, the iris heats faster than expected. This can be a consequence of an unexpected patient response, or an incorrect calibration of the irradiation’s treatment parameters. Once the IR camera **116b** senses that the temperature rose to a value high relative to a reference, such as to above 55 C, for safety reasons the feedback-based irradiation control signal can bring the irradiation power to zero via a hard stop.

[0184] FIG. 15 illustrates that the feedback system **116** can further include at least one of an alignment system **116c**, an eye tracker **116d**, a wavefront sensor **116e**, an iris scanner

116f, and an imaging system 114. The alignment system 116c can be related to, combined with, or analogous to any embodiment of the alignment system 135, described earlier, for example in relation to FIGS. 12A-C. Any of these feedback implementations can sense an alignment of one of the iris and the pupil relative to the irradiation delivery system 130, as discussed earlier.

[0185] FIG. 16C illustrates a mode of operation, or method 530 for such alignment-related feedback implementations. While FIG. 16C specifically refers to the eye tracker feedback 116d, an analogous process can be practiced with the analogous feedback alignment system 116c, iris scanner 116f, or imaging system 114. In a step 531, the eye tracker 116d can “sense alignment” between the iris 11, the pupil 13 and the irradiation delivery system 130. Sensing alignment in step 531 can lead to generating, in step 532, the feedback “Eye aligned Carry on irradiation”, which results in the irradiation source 120 maintaining the power of the irradiation, as shown by the top graph of FIG. 16C.

[0186] A central concern for the efficacy and safety of the irradiation treatment is that the eye 1, iris 11, and pupil 13 remain aligned with the irradiation delivery system throughout the irradiation. However, there is a possibility that the eye, iris, and pupil become misaligned. This can be caused by an involuntary eye movement by the patient, a reaction to a sensation of discomfort or pain by the patient, or a problem developing with the patient interface 137, such as the breaking of a vacuum suction, among others. Also, misalignment can be the natural consequence of the ophthalmologist not using a firm eye-fixation method, such as physically restraining the eyeball only by hand, or by pressure with a forceps. In these cases, the gaze of the eye can naturally drift away to a degree that it becomes misaligned with the pattern 210 and the irradiation delivery system 130.

[0187] FIG. 16C illustrates that the eye can get misaligned to a degree that the patterned irradiation 200p may reach the edge of the pupil 13. In such cases, the irradiation may start hitting the retina, a much more light-sensitive tissue. This raises a higher level of safety concerns. Embodiments of the feedback system 116 can handle such developments by the eye tracker 116d “sensing a misalignment”, or “misalignment sensed” in step 533. This can lead to a generation of a feedback signal “Eye misaligned! Safety Stop!” in step 534. The irradiation control system 110 can generate a corresponding feedback-based irradiation control signal for the irradiation source 120, which in response can execute a hard stop of the irradiation, as shown by the top graph. The step 534 can be accompanied with a signal to an operator, or user: “Realign at least one of the irradiation delivery system, the iris, and the pupil.”

[0188] FIG. 16D illustrates a process, or method 540 that flexibly manages naturally occurring misalignments. Steps 541-544 are analogous to steps 531-534, in relation to the eye losing alignment with the irradiation delivery system 120. However, the process 540 can dynamically manage if the misalignment developed not as a safety-threatening problem that required an irreversible hard stop, but as a consequence of a naturally shifting eye, which can be followed by the eye realigning with the irradiation delivery system 130. A typical situation can be when the eye is not docked to the ophthalmic stimulator 100 in a fixed manner with a patient interface 137, but is left free. In such embodiments, the patient may be fixating on a fixation light, but her gaze can be distracted for

a short period by natural processes such as a mild discomfort or blinking, after which the patient re-fixates on the fixation light, thus realigning the eye with the irradiation delivery system 130. Such scenarios can be managed by the process 540 via step 545, where the eye tracker 116d can “sense a realignment”, followed by step 546, where a feedback signal is generated confirming “Eye realigned. Resume irradiation”. The irradiation control system 110 can then generate a feedback-based irradiation control signal that makes the irradiation source 120 to resume the irradiation.

[0189] In some cases, the “stop irradiation 544—resume irradiation 546” sequence can be repeated several times. A notable embodiment can be a hand-held, mobile ophthalmic stimulator 100m, described below in relation to FIGS. 13A-C, where the eye can fall out from alignment relative to the irradiation delivery system 130m repeatedly, followed by the eye getting realigned with the irradiation delivery system 130m of the mobile ophthalmic stimulator 100m repeatedly, since the eyes of the patient are not held firmly in place by an immobilizing system.

[0190] Finally, FIG. 16E illustrates yet another feedback method or process 550. In this method, or process, 550, the feedback system 116 can include at least one of the pupilometer 116a and the imaging system 114, to sense at least one of a pupil characteristic or an iris characteristic, and to generate a feedback according to the sensed characteristic.

[0191] In step 551, the imaging system 114 may sense that the pupil 13 has a regular shape. In response, it may generate the feedback signal: “Progress regular. Carry on,” in step 552. However, in some cases, in step 553 the imaging system 114 may sense, or image, that an “irregular pupil shape” is emerging as a consequence of the irradiation. In other embodiments, the imaging system 114 may sense, or image, that at least one of a pupil characteristic and an iris characteristic is becoming unacceptable relative to a reference as a consequence of the irradiation. These situations can arise, when the pupil does not react according to medical expectations to the irradiation. A simple example can be that the pupil starts to lose its circular shape, and evolve toward an elongated, or irregular shape. A non-circular pupil can be perceived as an undesirable treatment outcome and therefore necessitates safety protocols within the feedback system 116 to manage or to counter-act it.

[0192] A corresponding step 554 can include the generation of a “modify irradiation pattern” feedback signal, possibly preceded by a “safety stop” feedback signal 554. The process 550 can be continued by the pattern generator 112e actually modifying the irradiation pattern 210 in step 555, followed by generating a “Pattern modified. Resume irradiation,” feedback 556.

[0193] FIG. 16E illustrates a characteristic example, where the pupil 13 starts to evolve from circular towards an elongated oval shape because of the irradiation. This undesirable process can be detected by the imaging system 114 in step 553. In response to the corresponding, feedback-based irradiation control signal, the irradiation delivery system 130 may change the irradiation pattern 210 from a circle into an oval that is oriented 90 degree opposite to the pupil’s oval. Such a modified irradiation pattern 210p may be successful to counter-act the development of the undesirable oval pupil.

[0194] Irradiation delivery systems 130 and 134 that are digitally controlled and active systems, like the beam modulators and beam scanners 134 of FIGS. 13A-B, and the

digitally controlled beam modulators **134** of FIGS. **9A-E**, can modify the irradiation patterns **210** relatively easily. The beam-shaping optics **132** of the optical systems in FIGS. **7A-F** with little or no digital, point-by-point control can also have some such functionalities. A simple embodiment can be the beam-shaping optics **132** including deformable mirrors. Actuators along the periphery, or along the perimeter of such deformable mirrors can elongate a circular pattern **210** into an oval pattern **210** by a simple cylindrical deformation of the mirror. Other low order wavefront deformations can be also introduced by deforming such a deformable mirror. Such deformable mirrors were also described earlier as systems that can enable the independent tuning of the $R_p(\text{inner})$ and the $R_p(\text{outer})$ radii of the pattern **210**, and also in relation to FIGS. **9B-C**.

[0195] Further embodiments can include further methods or processes, where the feedback system **116** includes the wavefront sensor **116e**, or the iris scanner **116f**, and the method includes generating a feedback based on a condition of at least one of the iris and the pupil, sensed by the wavefront sensor **116e**, or the iris scanner **116f**.

[0196] In yet other embodiments, the feedback system **116** can be configured to carry out a test and then generate a feedback signal based on the test. In a simple embodiment, during the treatment, a short light pulse can be sent to the eye, and the reaction time, or the reaction radius-change of the pupil can be measured and assessed by the feedback system **116**. A feedback-based irradiation control signal can then be generated based on this assessment.

[0197] In some cases, the feedback by the feedback system **116** can serve only a diagnostic purpose, not necessarily leading to the generation of a feedback signal to impact the irradiation. This feedback can be a visual feedback for the operator, or user of the ophthalmic stimulator **100** via a user interface **118-1a** to **118-1f**, or **118-2**. The user may, in response to this visual feedback, then modify the treatment. The feedback can be a wide variety of information, from pupil size to sensed temperature, to a pupil shape or alignment.

[0198] In some embodiments, an ophthalmic stimulator **100** for constricting the pupil **13** of an eye **1** can include an irradiation control system **110**, having a safety feedback system **116**, to generate a feedback-based irradiation control signal using a feedback of the safety feedback system **116**; an irradiation source **120**, coupled to the irradiation control system **110**, to generate an irradiation **200**; and an irradiation delivery system **130**, coupled to the irradiation control system **110**, to receive, the irradiation **200** from the irradiation source **120**, and to direct a patterned irradiation **200p** in a pattern **210** to a treatment region of an iris **11** of the eye **1**, guided by the feedback-based irradiation control signal. In these embodiments, the irradiation control system **110** can control at least one of the irradiation source **120** and the irradiation delivery system **130** with the feedback-based irradiation control signal so that the patterned irradiation **200p** causes a long-term constriction of the pupil **13**.

[0199] Including the safety feedback system **116** can be critically important to guarantee the safety of the operation of the ophthalmic stimulators **100**, especially those that are powerful enough to cause a long-term constriction of the pupil **13**. In the here-described embodiments, the safety feedback systems **116** are safety-oriented feedback systems, whose role can be critically different from simple guiding or aligning feedback systems which may only help the target-

ing of the irradiation, but are not part of ensuring the safety of the irradiation. Various embodiments of the safety feedback system **116** can provide feedback when the desired result has been achieved, as determined from a pupil size measurement, for example. This feedback ensures the safety of the treatment by signaling that further irradiation is not necessary and in fact may be harmful. In other embodiments, a feedback can be generated by the safety feedback system **116** if a misalignment has been detected, and the irradiation by the laser source **120L** may be inadvertently directed at the retina of the eye **1**. Yet other examples include generating a feedback to indicate that a temperature of the target tissue rose to a reference level, or exceeded a critical level. In these embodiments, the feedback of the safety feedback system **116** can indicate that the treatment goal has been achieved, or the possibility of an undesirable medical outcome, such as retinal exposure, or overheating the iris tissue. Receiving such a feedback from the safety feedback system **116** can prompt the irradiation control system **110** to generate a feedback-based irradiation control signal to stop, or to power down the irradiation. Employing such a safety feedback system **116** can ensure that the irradiation is stopped when the treatment goal is achieved, or when there is a possibility of an undesirable medical outcome. As such, including the safety feedback system **116** into the ophthalmic stimulator **100** can be critical to ensure its safe operation.

[0200] FIG. **15** illustrates that in some embodiments of the ophthalmic stimulator **100** the safety feedback system **116** can include at least one of . pupilometer **116a** and an imaging system **114**, to sense a diameter of the pupil, and to generate a feedback according to the sensed pupil diameter. The generated feedback can include at least one of “pupil radius is large relative to a reference, carry on irradiation”; and “pupil radius is sufficiently close to the, reference, power down irradiation”.

[0201] In some embodiments of the ophthalmic stimulator **100**, the safety feedback system **116** can include at least one of an infrared camera and a thermal sensor **116b**, to sense a temperature of the treatment region, and to generate a feedback according to the sensed temperature. The feedback can include at least one of “sensed temperature is low relative to a reference, carry on irradiation”; “sensed temperature is medium relative to the reference, start power down of irradiation”; and “sensed temperature is high relative to the reference, stop irradiation”.

[0202] In some embodiments of the ophthalmic stimulator **100**, the safety feedback system **116** can include at least one of an alignment system **116c**, an eye tracker **116d**, an iris scanner **116e**, and an imaging system **114**, to sense an alignment of one of the iris **11** and the pupil **13** with the irradiation delivery system **130**. The feedback can include at least one of: “the irradiation delivery system is aligned with one of the iris and the pupil, carry on irradiation”; and “the irradiation delivery system is misaligned with one of the iris and the pupil, stop irradiation, and realign at least one of the irradiation delivery system, the iris, and the pupil”.

[0203] With reference to FIG. **8B**, in some embodiments of the ophthalmic stimulator **100**, the irradiation source **120** can include a laser source **1201**, that can be a continuous wave laser, a pulsed laser, or a scanned laser. A wide variety of laser sources are known in the art that are useful for ophthalmic applications and can be employed as the irradiation laser source **120L**. In particular, femtosecond lasers,

with pulse length of 1-1,000 femtosecond and frequencies of 1 kHz-1 MHz have been widely used in the art, and can be used for the laser source **120**. Other lasers with longer pulse lengths, in the picosecond or even nanosecond range can be utilized as well.

[0204] In some embodiments of the ophthalmic stimulator **100**, the irradiation source **120**, the irradiation delivery system **130**, and the irradiation control system **110** can be configured so that the patterned irradiation causing the long-term constriction of the pupil includes cauterizing iris tissue. Such embodiments can cause permanent alteration of the iris tissue, and therefore can cause permanent shrinking of the pupil.

[0205] FIGS. 13A-C illustrate a class of mobile implementations of the ophthalmic stimulator **100m**, indicated by the label “m”. Some of these embodiments will be referred to as a mobile ophthalmic stimulator **100m**. FIG. 13A illustrates that this class of embodiments can include a mobile irradiation control system **110m**, to generate an irradiation control signal; an irradiation source **120m** coupled to the mobile irradiation control system **110m**, to generate an irradiation **200**; and an irradiation delivery system **130m**, coupled to the mobile irradiation control system **110m**, to receive the irradiation from the mobile irradiation source **120m**, and to deliver a patterned irradiation **200p** to an iris of the eye. In embodiments, the mobile irradiation control system **110m** can control at least one of the irradiation source **120m** and the irradiation delivery system **130m** with the irradiation control signal so that the patterned irradiation **200p** causes a temporary constriction of the pupil of the eye, without causing a permanent constriction of the pupil.

[0206] In embodiments, the mobile irradiation control system **110m** can include a mobile communication platform **111m**, or simply mobile platform **111m** that can be a mobile telephone **111m**, a mobile communication device, and a mobile tablet; and a mobile irradiation controller **110cm**, installed on the mobile communication platform **111m**, to generate the irradiation control signal. In a characteristic embodiment, the mobile irradiation controller **110cm** can be a software application, downloaded from a provider over the internet and installed or implemented on a mobile phone **111m**. In other embodiments, the mobile irradiation controller **110cm** can be a dedicated processor, for example, in a separate box that can be installed on the mobile communication platform **111m** by plugging it into the mobile communication platform **111m** through a USB port, headphone jack, or charging port. For brevity, the mobile irradiation controller **110cm** is sometimes simply referred to as irradiation controller **110cm**, where the “m” label indicates the mobile nature of this irradiation controller. The mobile phone **111m** itself then can be attached to the remainder of the mobile ophthalmic stimulator **100m**, which can be a table-top system that includes the mobile irradiation source **120m**, and the mobile irradiation delivery system **130m**, installed either in an office of an ophthalmologist, or in a user’s residence. In some embodiments, the mobile phone **111m** can be coupled to the rest of the ophthalmic stimulator **100m** by an electric connector or docking station. In other embodiments, the coupling and communication between the mobile phone **111m** and the rest of the ophthalmic stimulator **100m** can be a Wireless communication, for example through a Bluetooth, or a wi-fi system or channel.

[0207] The mobile communication platform **111m** can include a memory, to store the above mentioned software implementation of the mobile irradiation controller **110cm**; a processor, to execute the stored software implementation of the mobile irradiation controller **110cm**; and a user interface, to receive input from a user in relation to an operation of the memory and the processor.

[0208] Once the mobile platform **111m** or mobile phone **111m** is coupled to the rest of the mobile ophthalmic stimulator **100m**, a calibration process can be carried out, so that the mobile irradiation control system **110m** acquires information about the type and characteristics of the rest of the mobile ophthalmic stimulator **100m**. For example, information regarding the power and type of the light beam **200** generated by the irradiation source **120m**, and information regarding the type of signaling, communication and control protocols needed for the communication between the mobile platform **111m** and the rest of the mobile ophthalmic stimulator **100m**.

[0209] The irradiation delivery system **130m** can include at least one of a pattern generator, an optical beam shaper, a patterning optics, a beam profiler, and a digitally controlled irradiation optics. As in the other related embodiments, the mobile ophthalmic stimulator **100m** can be configured to increase a temperature of a treatment region of the iris to a range of 45-60 degrees Celsius.

[0210] The mobile irradiation control system **110m** can include a mobile imaging system **114m**, such as a mobile camera **114m**, to generate the irradiation control signal by generating an image of the iris of the eye by the mobile imaging system **114m**, receiving an image-based input, and generating the irradiation control signal to control at least one of the irradiation source **120m** and the irradiation delivery system **130m** to deliver the patterned irradiation according to the received image-based input.

[0211] In a characteristic example, the mobile irradiation control system **110m** can include a mobile phone **114m** that can be attached to the rest of the ophthalmic stimulator **100m** that is installed in a medical office as a desktop office device. As such, the irradiation source **120m** and the irradiation delivery system **130m** can themselves be a movable, light bench-top device that is mobile, but less mobile than the fully mobile platform **111m**, or mobile phone **111m**. Accordingly, in some embodiments they can be referred to as the mobile irradiation source **120m**, and the mobile irradiation delivery system **130m**.

[0212] The mobile camera **114m** of the mobile phone can image the iris **11** and pupil **13** of a patient who is looking into the camera **114m**. The mobile irradiation controller **110cm**, implemented on the mobile phone **111m**, can display the image of the pupil on the screen of the mobile phone **111m**, and also electronically overlay a proposed irradiation pattern **210**. The irradiation control application can then invite the doctor, or user, to modify the pattern within sonic limits of safety as the image-based input, such as to move the inner and the outer radii Rp(inner) and Rp(outer), while making sure that the pattern **210** remains on the iris **11**. Once the modification input is received, possibly together with some treatment parameters, the irradiation control application on the mobile phone **111m** can send an irradiation control signal to the irradiation source **120m** and the irradiation delivery system **130m** wirelessly with a Bluetooth channel. In response, the irradiation source **120m** and the irradiation

delivery system **130m** can generate and deliver the patterned irradiation **200p** onto the imaged iris **11**.

[0213] FIG. 13A illustrates that in some embodiments, the mobile irradiation control system **110m** can include an image processor **114ipm**, to receive the image of the iris from the imaging system **114m**, and to generate the image-based input based on a processing of the image of the iris. In some designs, this image processor **114ipm** can determine the inner and outer radii $R_p(\text{inner})$ and $R_p(\text{outer})$ of the ring pattern **210**, as well as the treatment parameters. There can be hybrid systems, where the image processor **114ipm** performs the above determinations, However, a user interface **118** of the mobile telephone **111m** still prompts a surgeon or operator to approve the displayed choices of the imager processor **114ipm**, as a safety measure.

[0214] In some implementations, the image processor **114ipm** can generate the image-based input by correlating an alignment pattern **138** with the generated image of the iris, in analogy to the alignment system **135** in FIG. 12C. Subsequently, the mobile irradiation control system can be configured to generate the irradiation control signal according to the received image-based input that includes a misalignment-warning signal, an alignment-guidance signal, or an irradiation-stop signal, if a misalignment is detected. In a characteristic case, the mobile phone can alert the ophthalmologist that a misalignment was detected, possibly also generating an alignment-guidance signal, such as which way to move the eye **1**, or the irradiation delivery system **130** to realign the eye and the irradiation delivery system **130**.

[0215] The ability of the mobile platform **111m** to communicate can play a very useful role in some implementations. In these designs, the mobile irradiation control system **110m** can include an on-board communication application, to receive the image of the iris from the imaging system **114m**, to communicate the received image to a central station **410** having an image processor, and to receive the image-based input from image processor of the central station **410**.

[0216] FIGS. 13B-C illustrate advanced embodiments, where not the mobile phone **111m** is attached to the rest of the ophthalmic stimulator **100m**, but the rest of the ophthalmic stimulator **100m** is attached to the mobile phone **111m**, to create a fully mobile ophthalmic stimulator **100m**.

[0217] FIG. 13B illustrates a design of the mobile ophthalmic stimulator **100m**, wherein the irradiation source **120m** and the irradiation delivery system **130m** are part of a small, compact irradiation device **120m/130m**; and the mobile irradiation control system **110m** is coupled to the irradiation device **120m/130m** to send the irradiation control signal by at least one of an electronic coupling, an electric coupling, a wireless coupling, and an optical coupling.

[0218] In the shown example, the irradiation source **120m** and the irradiation delivery system **130m** are configured to be electrically coupled to, and mechanically attached to the mobile irradiation control system **110m**. For example, the irradiation device **120m/130m** can be plugged into one of the ports of the mobile phone **111m**, such as into the USB port, or into the headphone jack, or the power charging port. In another example, the irradiation device **120m/130m** can be attached to the mobile phone **111m** by a clip, mini-pliers, or pincer.

[0219] FIG. 13C illustrates an example, in which the irradiation source **120m** is a light source of the mobile

irradiation control system **110m**, and the irradiation delivery system **130m** is mechanically attached to the mobile irradiation control system **110m**, to receive a light, generated by the irradiation source **120m**. In a characteristic example, the flashlight of the mobile phone **111m** itself can be used as the irradiation source **120m**. The flashlight of the mobile phone **111m**, of course, needs to be calibrated to gain control over the power irradiated by its irradiation **200**, and possibly filtered or dampened. Nevertheless, using the imaging capabilities of the mobile phones **111m** and their flashlight can make the mobile ophthalmic stimulator **100m** much cheaper and compact, and therefore suitable for being carried by a patient as a personal accessory. This aspect can be very useful if irradiation treatments are utilized that cause a temporary constriction of the pupil that lasts less than a day, and thus a once-a-day application in the morning does not secure the pupil constriction for the entire day. Such treatments may need to be refreshed as the day goes on. A portable, personalized, mobile phone-based ophthalmic stimulator **100m** can be the answer for the need for refreshing treatments during the day.

[0220] Obviously, safety is a high priority consideration for the mobile embodiments of the stimulator **100m** that are not operated by trained ophthalmologists. Moreover, achieving and preserving alignment for the duration of the treatment also becomes an elevated challenge for mobile stimulator **100m**. Mobile stimulators **100m** can address these concerns, by practicing the method, or process **540**, illustrated in FIG. 16D. It is recalled here, that in step **543**, if the imaging system **114**, the alignment system **116c**, or the eye tracker **116d** sense a misalignment, then they can induce the generation of a feedback-based irradiation control signal that makes the irradiation source **120m** stop the irradiation **200**. Implementing this imaging-triggered “safety stop” process makes mobile stimulators **100m** safe, and minimizes undesirable retinal exposure.

[0221] Moreover, if the eye gets realigned, for example, because the user moves either the hand-held mobile phone **111m**, or moves her/his gaze, then the imaging system **114**, or its equivalents, can sense the realignment in step **545**, and the irradiation controller **110m** can cause the restart the irradiation. These stop **543**-restart **545** steps can be performed repeatedly, as, for example, the handheld mobile phone **111m** is moving in the patient’s hand.

[0222] An interrupted, or multiply interrupted irradiation treatment may take longer to achieve the temperature rise required for the desired pupil constriction, and to administer the treatment for the time necessary for efficacy. Therefore, mobile stimulators **100m** can include at least one of a thermal camera, an infrared camera and a thermal sensor **116b**, to track an amount of time a treatment region of the iris had a temperature in a predetermined range. In an example, the irradiation controller **110m** may add up the multiply interrupted time-segments, when the treatment region of the iris was at the prescribed temperature, and ensure that the treatment region has been held at the prescribed temperature range for the time interval necessary to achieve the targeted pupil constriction. For example, the IR sensor **116b** can track that the treated ring **210r** of the iris **11** remains at 55 Celsius for a prescribed time, such as for 20 seconds, or for 40 seconds, in order to achieve a pupil constriction that will last all day.

[0223] In some embodiments, the safety stop **543**-restart **545** steps can be also performed under the control of the

central station **410**. In such embodiments, it can be the image processor of the central station **410** that senses the misalignment of the patterned irradiation relative to the iris or the pupil, as well as that senses the realignment, prompting the generation of the restart command.

[0224] Finally, the central station **410** can perform monitoring functions over a series of treatments performed by the mobile ophthalmic stimulator **100m**. In some embodiments, the mobile stimulator **100m** can be configured to take and send the image of the iris to the central station **410** for monitoring, to receive a monitoring-based control signal from the central station, and to generate the irradiation control signal in accordance with the received monitoring-based control signal. For example, the images, sent by the stimulator **100m**, can be analyzed by the central station **410**. This analysis can recognize that the treatment is inducing an undesirable effect in the retina over the term of several treatments. In such case, the central station may send out a monitoring-based control signal to the mobile stimulator **100m** to either prevent the user from administering further treatments, or to change a treatment parameter, such as to reduce a power or intensity of the patterned irradiation **200p**. Such central station-related systems are described next.

[0225] FIG. 14 illustrates a networked system **400** of ophthalmic stimulators for temporarily constricting eye-pupils. The networked system **400**, or mobile network **400**, can include a set of mobile ophthalmic stimulators **100m-1**, **100m-2**, . . . **100m-N**, collectively referred to as mobile ophthalmic stimulators **100m-i**, each mobile ophthalmic stimulator **100m-i** including a mobile irradiation control system **110m-i**, to generate an irradiation control signal; an irradiation source **120m-i**, coupled to the irradiation control system **110m-i**, to generate an irradiation; and an irradiation delivery system **130m-i**, coupled to the mobile irradiation control system **110m-i**, to receive the irradiation from the irradiation source **120m-i**, and to deliver a patterned irradiation **200p** to an iris of the eye; wherein the mobile irradiation control system **110m-i** controls at least one of the irradiation source **120m-i** and the irradiation delivery system **130m-i** with the irradiation control signal so that the patterned irradiation **200p** causes a temporary constriction of the pupil of the eye, without causing a permanent constriction of the pupil.

[0226] The networked system **400** further includes a central station **410**, including a central image processor, wherein the mobile irradiation control systems **110m-i** of the mobile ophthalmic stimulators **100m-i** and the central station **410** are configured to communicate through a communication network. In this section, the term mobile ophthalmic stimulator **100m-i** encompasses all embodiments described in relation to FIGS. 13A-C.

[0227] In embodiments of the networked system **400**, each mobile irradiation control system **110m-i** can include a mobile communication platform **111m-i**, including at least one of a mobile telephone, a mobile communication device, and a mobile tablet; and a mobile irradiation controller **110cm-i**, implemented on the mobile communication platform **111m-i**, to generate the irradiation control signal, in embodiments, the mobile communication platforms **111m-i** can include a memory, to store a software implementation of the mobile irradiation controller **110cm-i**; a processor, to execute the stored software implementation of the mobile irradiation controller **111cm-i**; and a user interface, to receive input from a user in relation to an operation of the

memory and the processor. In embodiments, the mobile ophthalmic stimulators can be configured to increase a temperature of a treatment region of the iris to a range of 45-60 degrees Celsius.

[0228] Each mobile irradiation control system **110m-i** can include an imaging system **114m-i**, to generate the irradiation control signal by generating an image of the iris of the eye by the imaging system **114m-i**, receiving an image-based input, and generating the irradiation control signal to control at least one of the irradiation **120m-i** source and the irradiation delivery system **130m-i** to deliver the patterned irradiation **200p** according to the received image-based input.

[0229] In some characteristic embodiments, the mobile irradiation control systems **11m-i** can include an image processor **114ipm-i**, to receive the image of the iris from the imaging system, and to generate the image-based input based on a processing of the image of the iris. FIG. 14, the image processors **114ipm-i** are not shown for scarcity of space. Embodiments of the image processors **114ipm-i** have been shown and described earlier, such as in FIG. 6A. As described earlier, the on-board image processors **114ipm-i**, can generate an image-based input for the irradiation control systems **110m-i**, which then can control the rest of the mobile ophthalmic stimulators **100m-i** accordingly. In such embodiments, the communications of the mobile ophthalmic stimulators **100m-i** with the central station **410** can be a recording of the results of the image processing, and the record of the treatments performed by the mobile ophthalmic stimulators **100m-i**.

[0230] In other embodiments, each ophthalmic stimulator **100m-i** can be configured to send the image of the iris to the central station **410**; and the central station **410** can be configured to analyze the received image by a central image processor **410ip**, and to respond to the sending mobile ophthalmic stimulator **100m-i** with the image-based input based on the analysis. This communication and analysis can be real-time, actionable. In other cases, it can be a post-treatment, recording the actions type communication.

[0231] In real-time embodiments, each ophthalmic stimulator **100m-i** can be configured to generate and to send the image of the iris to the central station **410** before the irradiation delivery system delivers **130m-i** the patterned irradiation to the iris; and the central station **410** can be configured to respond to the sending ophthalmic stimulator **100m-i** with the image-based input that indicates whether the central station **410** authorizes the irradiation delivery system **130-i** of the ophthalmic stimulator **100m-i** to deliver the patterned irradiation to the iris.

[0232] Clearly, such preauthorization-based networked systems **400** have safety benefits, as when the patient intends to use the mobile ophthalmic stimulator **100m-i**, the stimulator **100m-i** first needs to send an image of the iris to be treated to the central station **410**. This gives a chance for the central image processor **410ip** to analyze the image of the iris, and if it finds anything that raises a medical concern, such as a shape change, or an unexpected discoloration, the central station **410** can communicate a "Treatment not authorized" imaging-based input to the mobile stimulator **100m-i**, which then prevents the mobile stimulator **100m-i** from irradiating the iris when medical concerns have been raised by the image analysis.

[0233] In a related embodiment of the networked system **400**, each ophthalmic stimulator **100m-i** can be configured to

generate, and to send, the image of the iris to the central station **410** before the irradiation delivery system **130m-i** delivers the patterned irradiation **200p** to the iris; and the central station **410** can be configured to respond to the sending mobile ophthalmic stimulator **100m-i** with the image-based input that indicates irradiation parameters to be used by the irradiation delivery system **130m-i** of the mobile ophthalmic stimulator **100m-i** when delivering the patterned irradiation to the iris.

[0234] The safety aspects of this embodiment are quite similar to the previous one. One of the differences is that the imaging-based input from the central station is not a binary “authorized-not authorized” input, but a quantitative input, nuanced input. In a characteristic example, the central image processor **410ip** can notice a small discoloration of the iris in the image, sent in by the mobile stimulator **100m-i**. However, the discoloration may be small enough so that a hard-stop “Treatment not authorized” input may be excessive. In such cases, the central image processor **410ip** can respond instead by a message of “Reduce power of irradiation in next treatment” input. In some embodiments, the central image processor **410ip** can even schedule a follow-up imaging, to check how the iris reacted to the reduced power irradiation: was the reduction sufficient to eliminate the discoloration, or further analysis is needed.

[0235] In some embodiments, the central imaging processor **410ip** of the central station **410** can be configured to perform a medical analysis of the image of the iris, and to respond to the sending ophthalmic stimulator **100m-i** with the image-based input that indicates if a negative medical condition was found by the analysis. The medical analysis can take place in a number of ways. The central station **410** can engage in an automated medical analysis, where for example past images of the iris, recalled from a memory, are compared to the present image. Or, the image of the iris can be compared to a database, compiled from tracking a large number of irises. Some embodiments can use artificial intelligence systems to recognize, and to evaluate the negative medical condition, such as an inflammation of the iris. Or, the image processor can flag the image, and request an opinion or analysis by a human specialist.

[0236] The negative medical condition can also be a wide range of conditions, including a change of color of the iris, a change of an optical characteristic, and a change of shape of the iris.

[0237] In some advanced embodiments, the mobile ophthalmic stimulators **100m-i** can be configured to test the iris **11** and to send a test result to the central station **410**; and the central station **410** can be configured to perform a medical analysis of the test result, and to respond to the sending mobile ophthalmic stimulators **100m-i** with the Linage-based input that indicates if a negative medical condition was found by the analysis. The mentioned test of the iris can include irradiating the iris with a test irradiation, and measuring a constriction of the pupil in response to the test irradiation. The performing a medical analysis can include recalling, a previous test result, as mentioned. Finally, the detection of a negative medical condition can include comparing the test result with the previous test result, and finding the test result less acceptable than the previous test result. In other embodiments, the comparison can be made not with past measurements or tests on the same iris, but to a database of a large number of irises. This database can be organized

into groups according to many shared traits, so that patients with comparable medical situations and characteristics are compared by the database.

[0238] As mentioned in relation to the mobile stimulators **100m** of FIGS. **13A-C** earlier, in another class of embodiments, the mobile ophthalmic stimulators **100m-i** can be configured to send alignment data to the central station **410** regarding an alignment of the patterned irradiation **200p** with at least one of the iris and the pupil; and the central station **410** can be configured to evaluate the alignment data; and to send a control signal to stop the patterned irradiation **200p** when the patterned irradiation **200p** is evaluated to be misaligned with at least one of the iris and the pupil. In some embodiments, the alignment data can be generated by the imaging system **114m**. In others, by various embodiments of the alignment system **135**, possibly using the patient interface **137** and the alignment pattern **138**. In imaging-based embodiments, the control signal can be analogous to the image-based input, described earlier.

[0239] Generally speaking, in some embodiments of the networked system **400** the mobile irradiation control systems **110m-i** of the mobile ophthalmic stimulators **100m-i** and the central station **410** can be configured to communicate regarding safety monitoring of the irradiations and treatments by an interface, or dedicated block or code **413**. This is a generic concept that encompasses communication regarding all major safety monitoring channels, including expected and unexpected medical outcomes, treatment parameters, proper alignment, and test results, from the viewpoint of safety. As described, the safety monitoring can result prompting a dedicated block, processor, or code **416** to signal or order preventive shutdowns of the mobile stimulators.

[0240] Analogous communications can be performed by a treatment outcome monitoring block, dedicated processor, or code **412**. Communications about treatment outcomes can then be used by a block, dedicated processor, or piece of code **415**, to develop and assemble a statistics of the treatment outcomes with the purpose of improving the understanding and the operations of the networked system **400** for the benefit of the patients. This communication channel can, of course, also be useful for pushing out new versions of treatment software from the central station **410** to the individual mobile stimulators **100m-i**.

[0241] These communications may not be real time, or actionable. In some embodiments, for example, the mobile irradiation control systems **110m-i** of the mobile ophthalmic stimulators **100m-i** and the central station **410** can be configured to communicate treatment outcomes after an irradiation has been performed. In other embodiments, they can be configured to communicate regarding patient data, which then can be stored in a dedicated processor and memory **411**.

[0242] While this document contains many specifics, these should not be construed as limitations on the scope of an invention or of what may be claimed, but rather as descriptions of features specific to particular embodiments of the invention. Certain features that are described in this document in the context of separate embodiments can also be implemented in combination in a single embodiment. Conversely, various features that are described in the context of a single embodiment can also be implemented in multiple embodiments separately or in any suitable subcombination. Moreover, although features may be described above as acting in certain combinations and even initially claimed as

such, one or more features from a claimed combination can in some cases be excised from the combination, and the claimed combination may be directed to a subcombination or a variation of a subcombination.

1. An ophthalmic stimulator for temporarily constricting a pupil of an eye, comprising:

- a mobile irradiation control system, to generate an irradiation control signal;
- an irradiation source, coupled to the irradiation control system, to generate an irradiation; and
- an irradiation delivery system, coupled to the mobile irradiation control system,
 - to receive the irradiation from the irradiation source and
 - to deliver a patterned irradiation to an iris of the eye; wherein

the mobile irradiation control system controls at least one of the irradiation source and the irradiation delivery system with the irradiation control signal so that the patterned irradiation causes a temporary constriction of the pupil of the eye, without causing a permanent constriction of the pupil.

2. The ophthalmic stimulator of claim 1, the mobile irradiation control system comprising:

- a mobile communication platform, including at least one of a mobile telephone, a mobile communication device, and a mobile tablet; and
- a mobile irradiation controller, installed on the mobile communication platform, to generate the irradiation control signal.

3. The ophthalmic stimulator of claim 2, the mobile communication platform comprising:

- a memory, store a software implementation of the irradiation controller;
- a processor, to execute the software implementation of the irradiation controller; and
- a user interface, to receive input from a user in relation to an operation of the memory and the processor.

4. The ophthalmic stimulator of claim 1, the irradiation delivery system comprising:

- at least one of a pattern generator, an optical beam shaper, a patterning optics, a beam profiler, and a digitally controlled irradiation optics.

5. The ophthalmic stimulator of claim 1, wherein:

the ophthalmic stimulator is configured to increase a temperature of a treatment region of the iris to a range of 45-60 degrees Celsius.

6. The ophthalmic stimulator of claim 1, the mobile irradiation control system comprising:

- an imaging system, to generate the irradiation control signal by
 - generating an image of the iris of the eye by the imaging system
 - receiving an image-based input, and
 - generating the irradiation control signal to control at least one of the irradiation source and the irradiation delivery system to deliver the patterned irradiation according to the received. image-based input.

7. The ophthalmic stimulator of claim 6, wherein:

the patterned irradiation impacts the iris in a ring pattern; and

the image-based input is generated by a user selecting at least one of an inner radius and an outer radius of the ring pattern.

8. The ophthalmic stimulator of claim 6, the mobile irradiation control system comprising:

- an image processor,
 - to receive the image of the iris from the imaging system, and
 - to generate the image-based input based on a processing of the image of the iris.

9. The ophthalmic stimulator of claim 8, wherein:

the generating the image-based input includes correlating an alignment pattern with the generated image of the iris; and

the mobile irradiation control system is configured to generate the irradiation control signal according to the received image-based input that includes at least one of a misalignment warning signal, an alignment-guidance signal, and an irradiation-stop signal, if a misalignment is detected.

10. The ophthalmic stimulator of claim 6, the mobile irradiation control system comprising:

- a communication application,
 - to receive the image of the iris from the imaging system,
 - to communicate the received image to a central station having an image processor, and
 - to receive the image-based input from the central station.

11. The ophthalmic stimulator of claim 1, wherein:

the irradiation source and the irradiation delivery system are part of an irradiation device; and

the mobile irradiation control system is coupled to the irradiation device to send the irradiation control signal by at least one of

- an electronic coupling, an electric coupling, a wireless coupling, and an optical coupling.

12. The ophthalmic stimulator of claim 1, wherein:

the irradiation source and the irradiation delivery system are configured to be electrically coupled, and mechanically attached to the mobile irradiation control system.

13. The ophthalmic stimulator of claim 1, wherein:

the irradiation source is a light source of the mobile irradiation control system; and

the irradiation delivery system is mechanically attached to the mobile irradiation control system, to receive a light, generated by the irradiation source.

14. The ophthalmic stimulator of claim 1, wherein:

the ophthalmic stimulator is configured to stop the patterned irradiation when the patterned irradiation is sensed to be misaligned with at least one of the iris and the pupil by an image processor of one of the ophthalmic stimulator and the central station.

15. The ophthalmic stimulator of claim 14, wherein:

the ophthalmic stimulator is configured to resume the stopped patterned irradiation, when the patterned irradiation is sensed to be realigned with at least one of the iris, and the pupil.

16. The ophthalmic stimulator of claim 15, comprising:

- at least one of a thermal camera, an infrared camera and a thermal sensor, to track an amount of time a treatment region of the iris had a temperature in a predetermined range.

17. The ophthalmic stimulator of claim 1, wherein:

the mobile irradiation control system comprises an imaging system, to image the iris of the eye; and the ophthalmic stimulator is configured

to send the image of the iris to a central station for monitoring,
to receive a monitoring-based control signal from the central station, and
to generate the irradiation control signal in accordance with the received monitoring-based control signal.

* * * * *

专利名称(译)	用于非瞳孔收缩的移动平台		
公开(公告)号	US20180104506A1	公开(公告)日	2018-04-19
申请号	US15/372390	申请日	2016-12-07
[标]申请(专利权)人(译)	ZIMANYI GERGELY†		
申请(专利权)人(译)	KURTZ, RONALD MICHAEL ZIMANYI, GERGELY T.		
当前申请(专利权)人(译)	KURTZ, RONALD MICHAEL ZIMANYI, GERGELY T.		
[标]发明人	KURTZ RONALD MICHAEL ZIMANYI GERGELY T		
发明人	KURTZ, RONALD MICHAEL ZIMANYI, GERGELY T.		
IPC分类号	A61N5/06 A61B3/14 A61B5/00 A61F9/00 H01S3/00		
CPC分类号	A61N5/06 A61B3/14 A61B5/0002 A61N2005/065 H01S3/0007 A61N2005/0635 A61F9/00 A61B3/112 A61N5/0622 A61N2005/0626 A61N2005/0648		
外部链接	Espacenet USPTO		

摘要(译)

一种用于临时约束艺术眼的瞳孔的眼科刺激器，包括：移动照射控制系统，用于产生照射控制信号；照射源，与照射控制系统耦合以产生照射；以及照射输送系统，其耦合到所述移动照射控制系统，以接收来自所述照射源的照射，并且将图案化的照射递送到眼睛的虹膜；其中所述移动照射控制系统利用所述照射控制信号控制所述照射源和所述照射传递系统中的至少一个，使得所述图案化照射导致眼睛的瞳孔暂时收缩，而不引起所述瞳孔的永久收缩。

