



US 20170181704A1

(19) **United States**

(12) **Patent Application Publication**
ROGERS et al.

(10) **Pub. No.: US 2017/0181704 A1**

(43) **Pub. Date: Jun. 29, 2017**

(54) **APPENDAGE MOUNTABLE ELECTRONIC DEVICES CONFORMABLE TO SURFACES**

H05K 1/11 (2006.01)

A61B 42/10 (2006.01)

H05K 1/02 (2006.01)

(71) Applicant: **The Board of Trustees of the University of Illinois, Urbana, IL (US)**

(52) **U.S. Cl.**

CPC *A61B 5/6806* (2013.01); *A61B 42/10* (2016.02); *A61B 5/01* (2013.01); *A61B 5/4875* (2013.01); *H05K 1/189* (2013.01); *H05K 1/0283* (2013.01); *H05K 3/303* (2013.01); *H05K 1/162* (2013.01); *H05K 1/11* (2013.01); *A61N 1/0456* (2013.01); *A61N 1/0476* (2013.01); *A61B 2562/0271* (2013.01); *H05K 2201/10151* (2013.01); *H05K 2201/10098* (2013.01); *H05K 2201/0133* (2013.01); *H05K 2201/055* (2013.01)

(72) Inventors: **John A. ROGERS, Champaign, IL (US); Ming YING, Urbana, IL (US); Andrew BONIFAS, Urbana, IL (US); Nanshu LU, Urbana, IL (US)**

(21) Appl. No.: **15/375,514**

(22) Filed: **Dec. 12, 2016**

Related U.S. Application Data

(63) Continuation of application No. 13/853,770, filed on Mar. 29, 2013, now Pat. No. 9,554,484.

(60) Provisional application No. 61/794,004, filed on Mar. 15, 2013, provisional application No. 61/636,527, filed on Apr. 20, 2012, provisional application No. 61/618,371, filed on Mar. 30, 2012.

Publication Classification

(51) **Int. Cl.**

A61B 5/00 (2006.01)

A61B 5/01 (2006.01)

H05K 1/18 (2006.01)

A61N 1/04 (2006.01)

H05K 3/30 (2006.01)

H05K 1/16 (2006.01)

(57) **ABSTRACT**

Disclosed are appendage mountable electronic systems and related methods for covering and conforming to an appendage surface. A flexible or stretchable substrate has an inner surface for receiving an appendage, including an appendage having a curved surface, and an opposed outer surface that is accessible to external surfaces. A stretchable or flexible electronic device is supported by the substrate inner and/or outer surface, depending on the application of interest. The electronic device in combination with the substrate provides a net bending stiffness to facilitate conformal contact between the inner surface and a surface of the appendage provided within the enclosure. In an aspect, the system is capable of surface flipping without adversely impacting electronic device functionality, such as electronic devices comprising arrays of sensors, actuators, or both sensors and actuators.

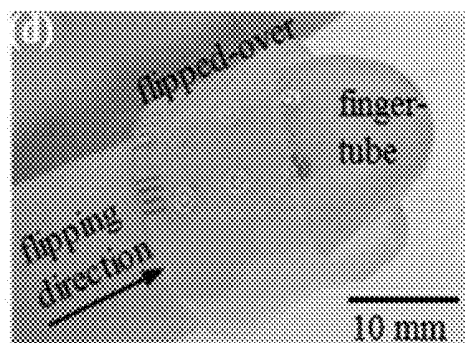
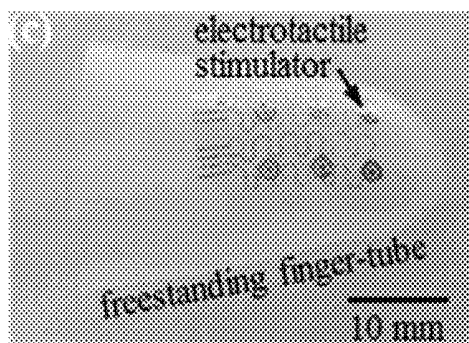
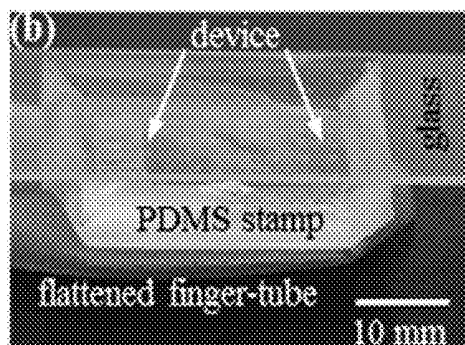
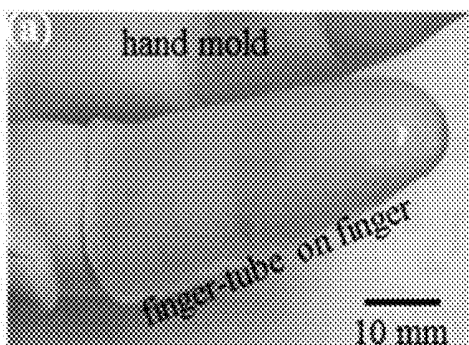

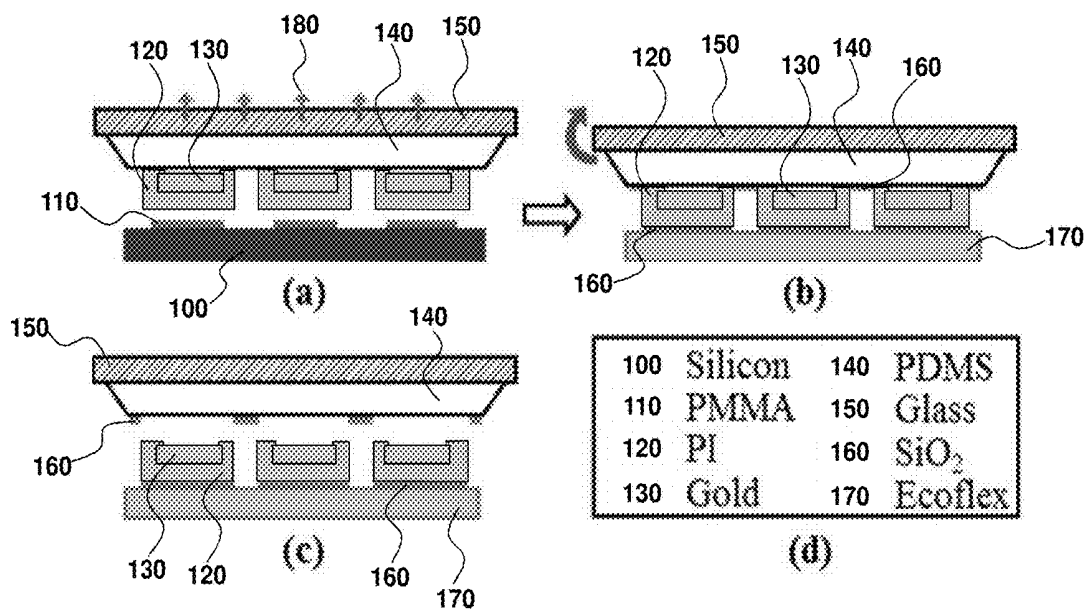

Figure 1

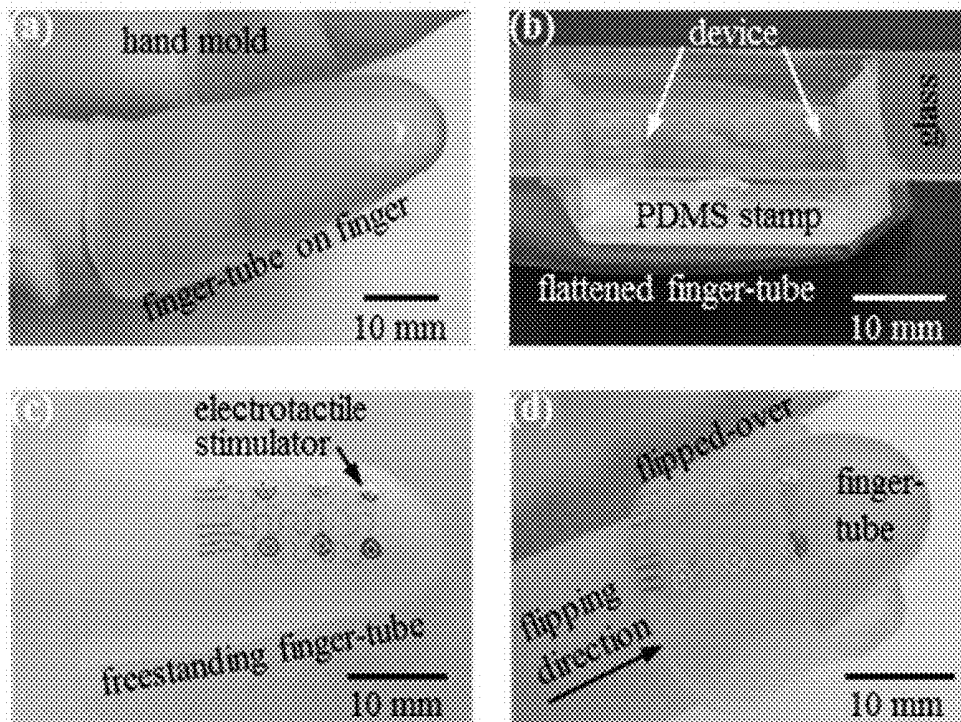

Figure 2

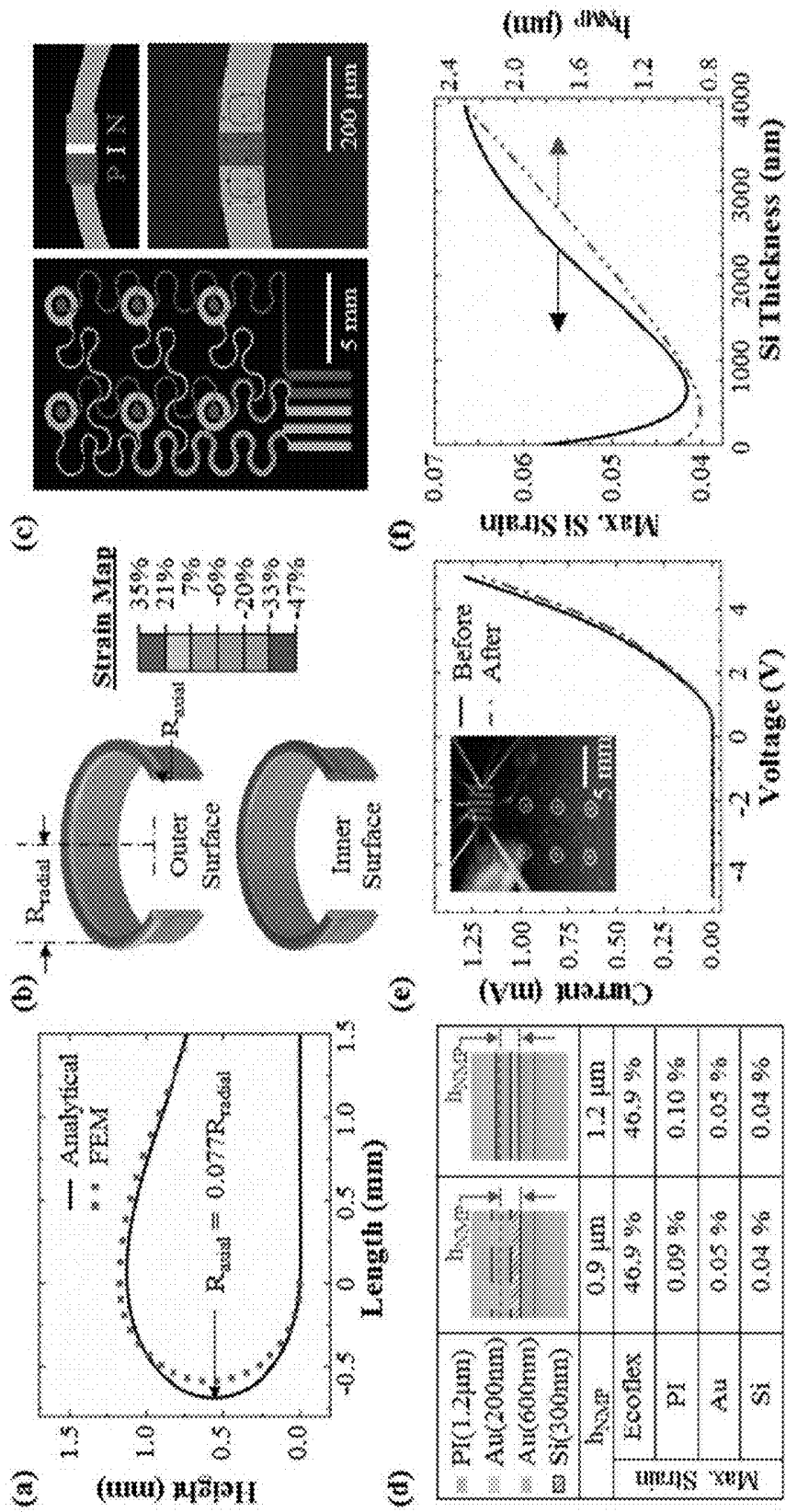

Figure 3

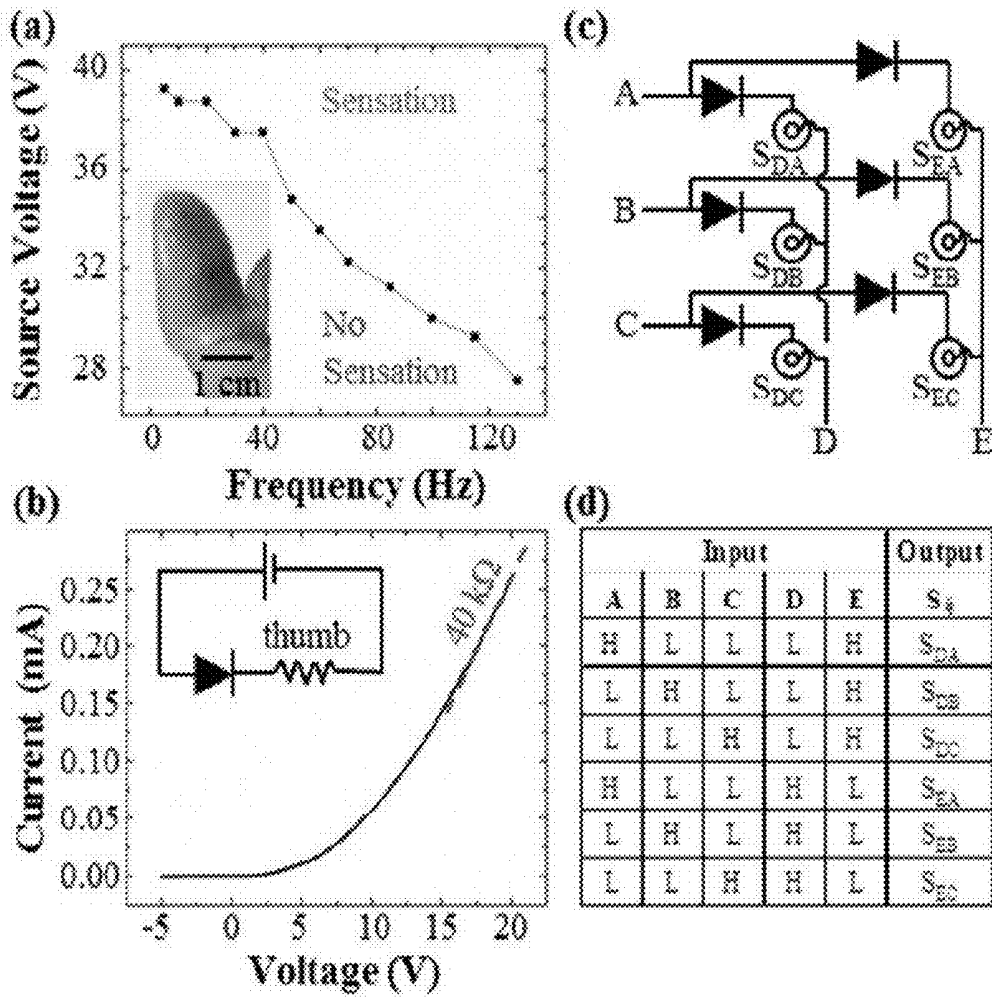

Figure 4

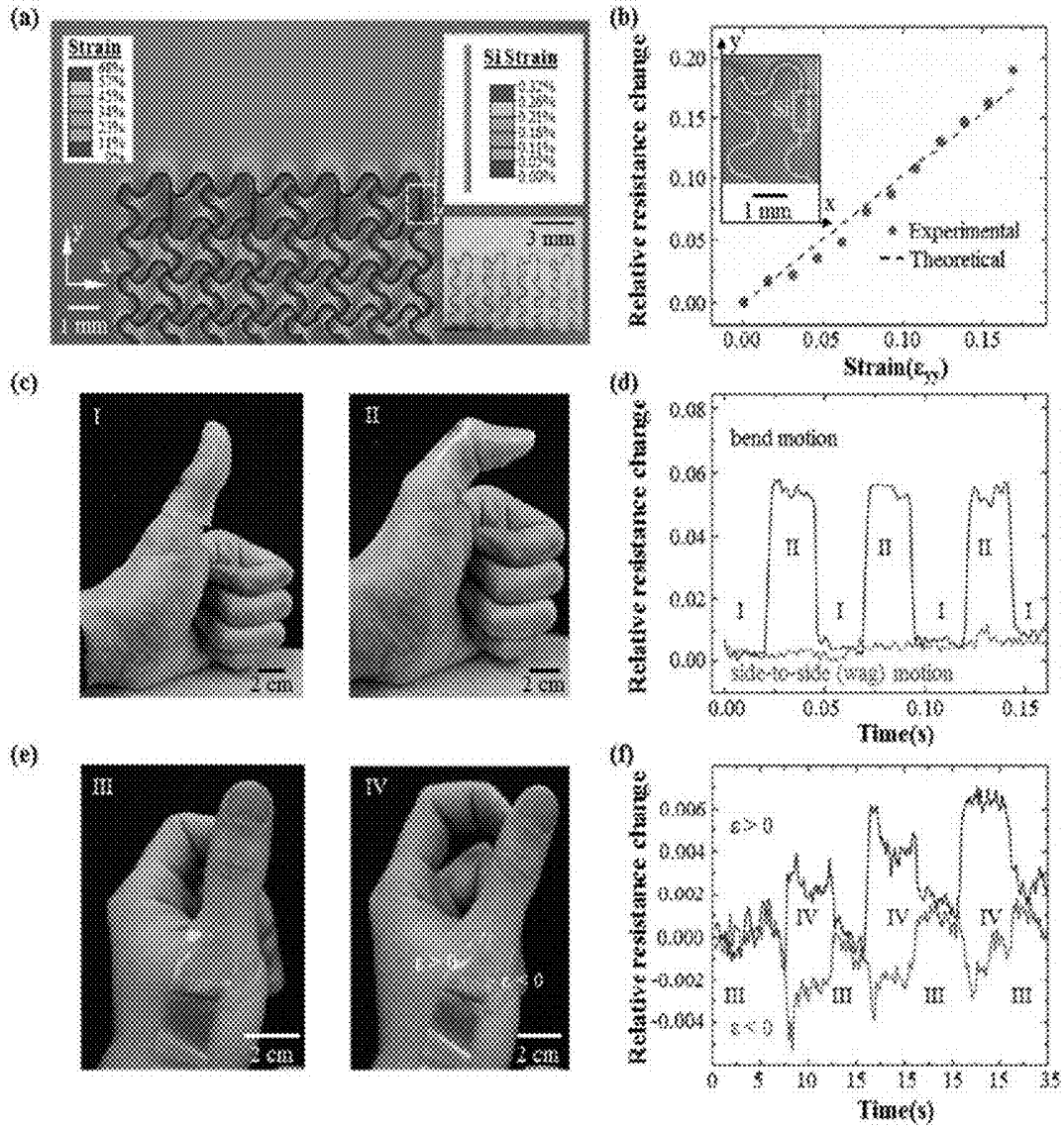

Figure 5

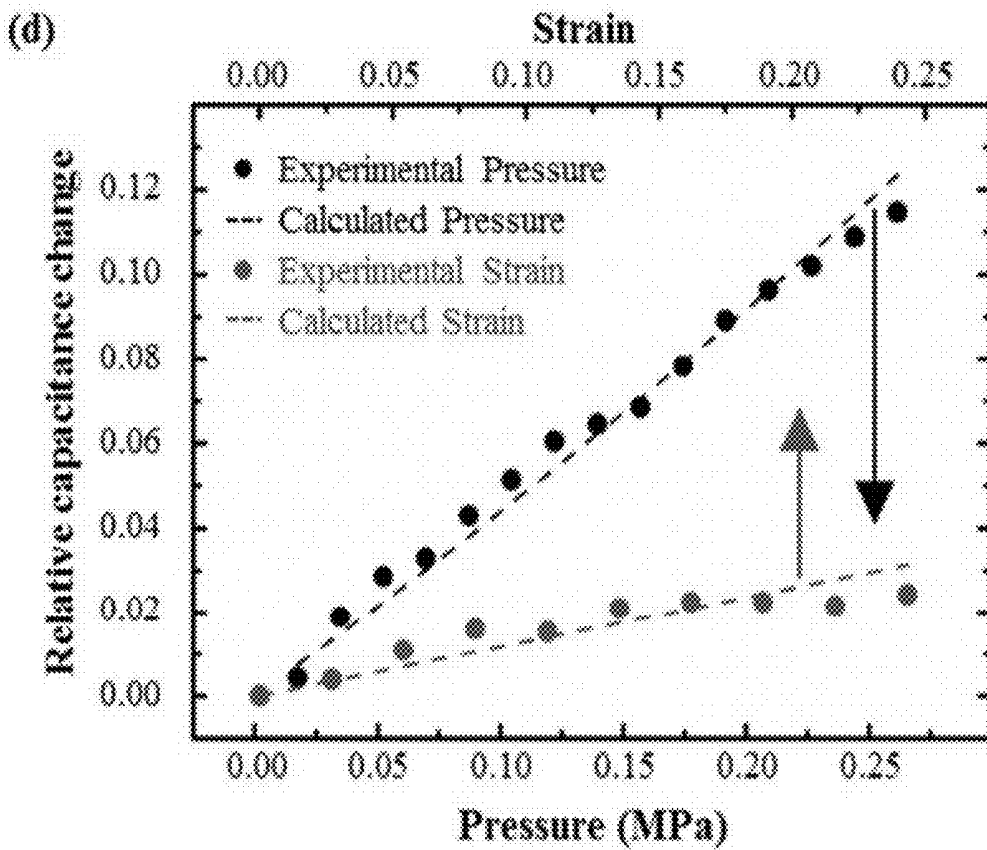
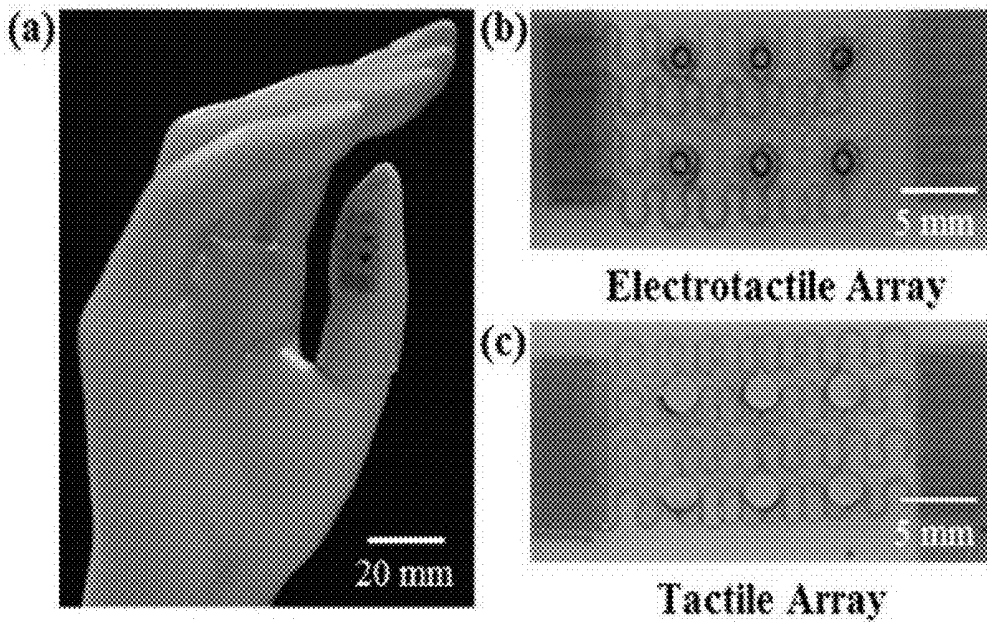

Figure 6

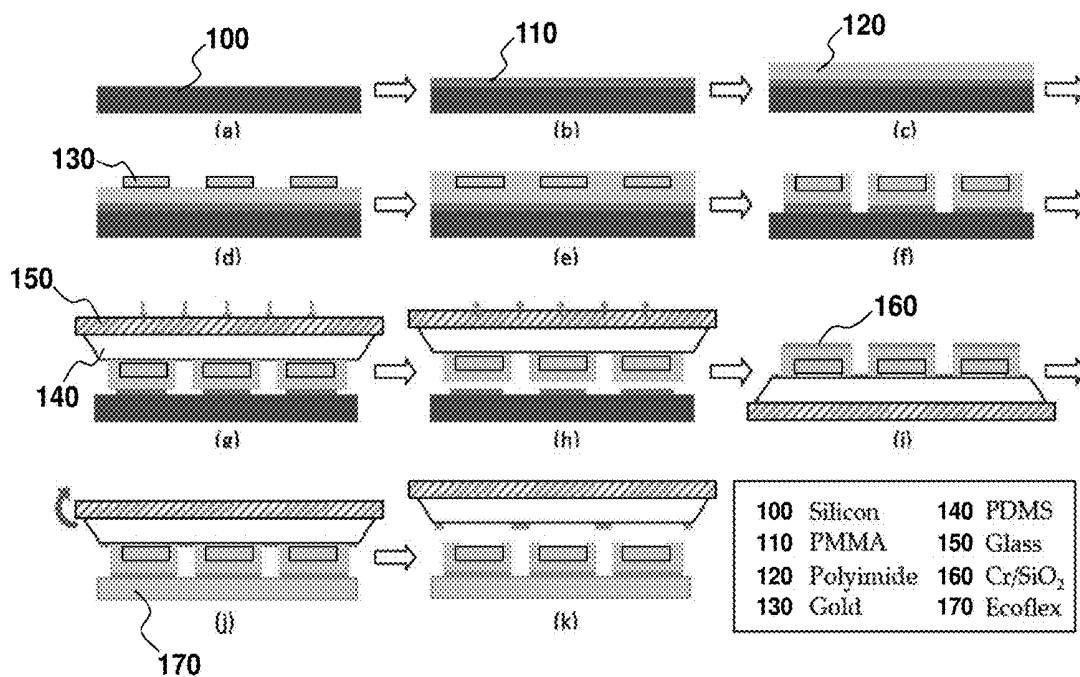

Figure 7

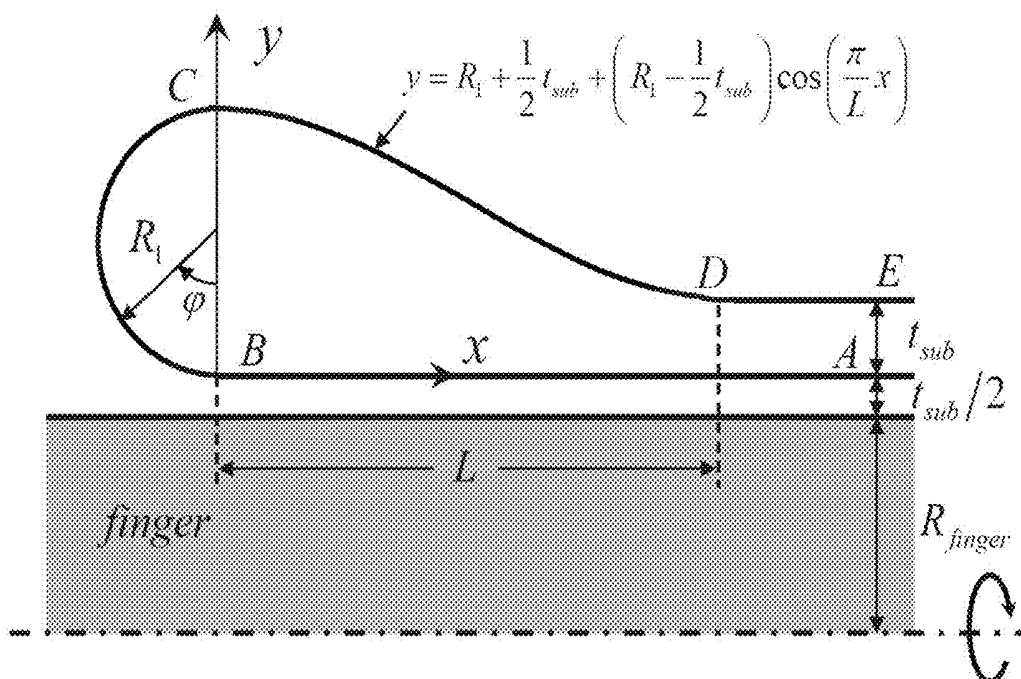

Figure 8

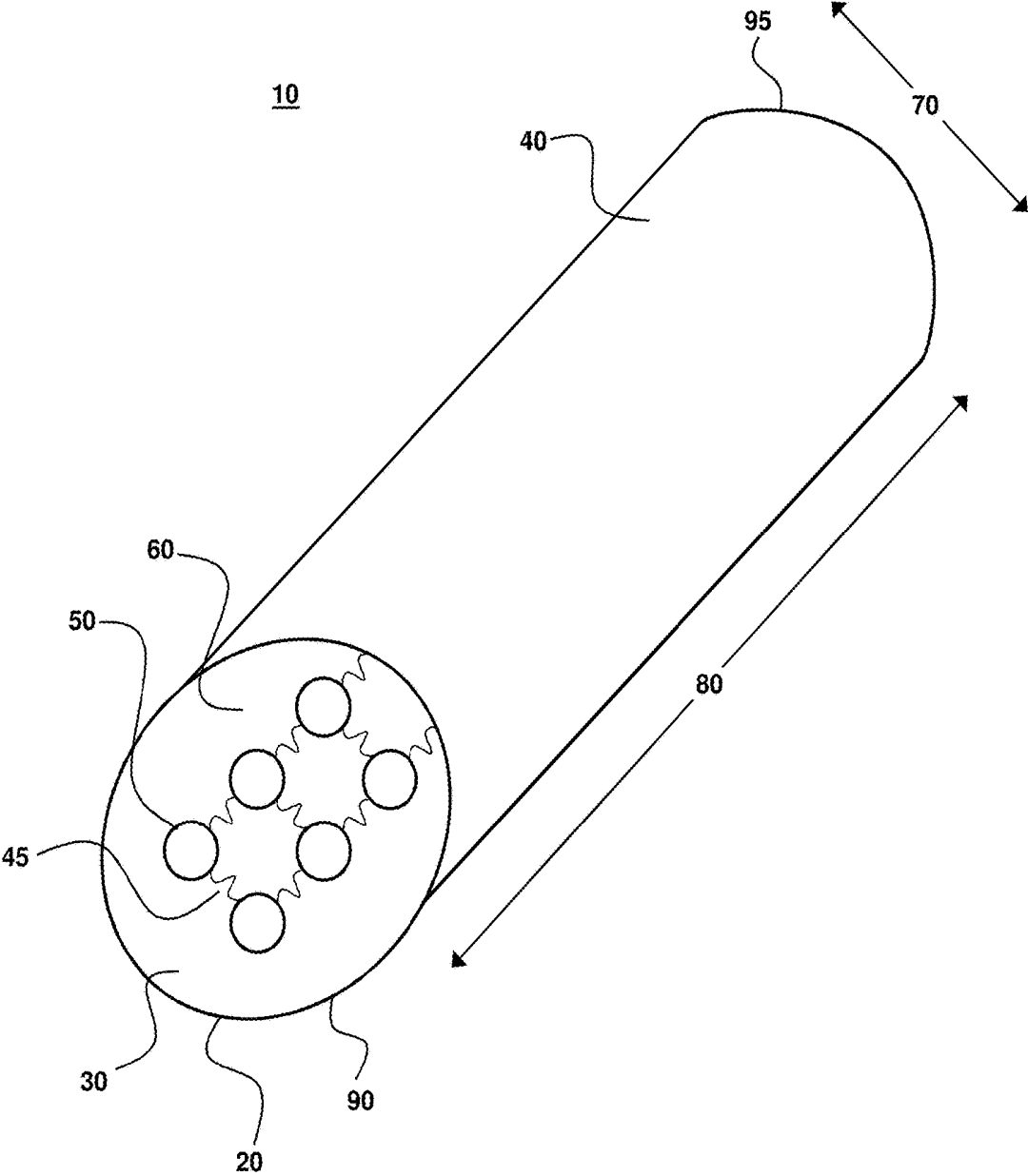

Figure 9

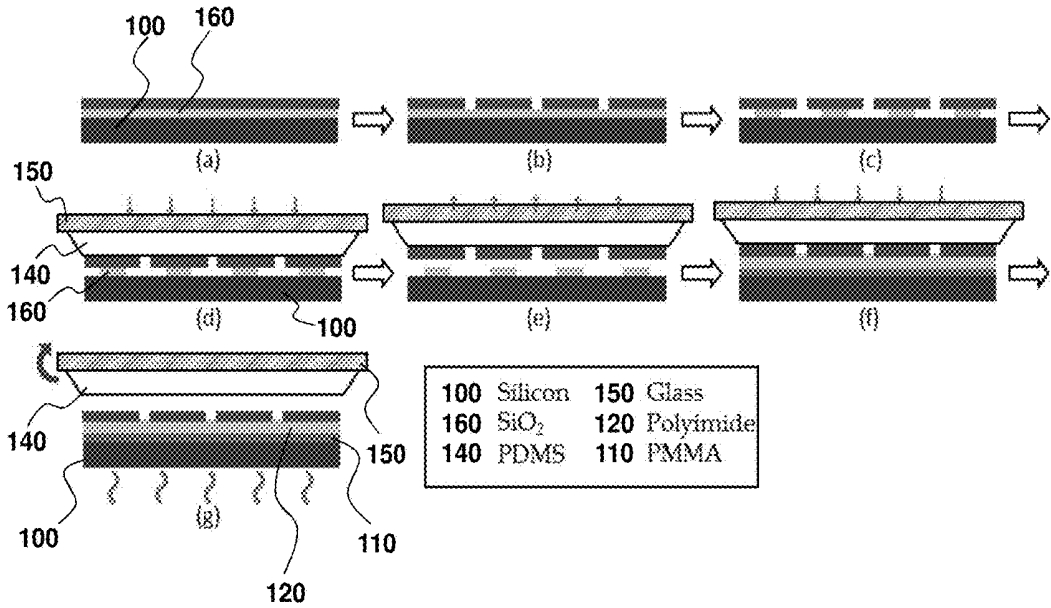

Figure 10

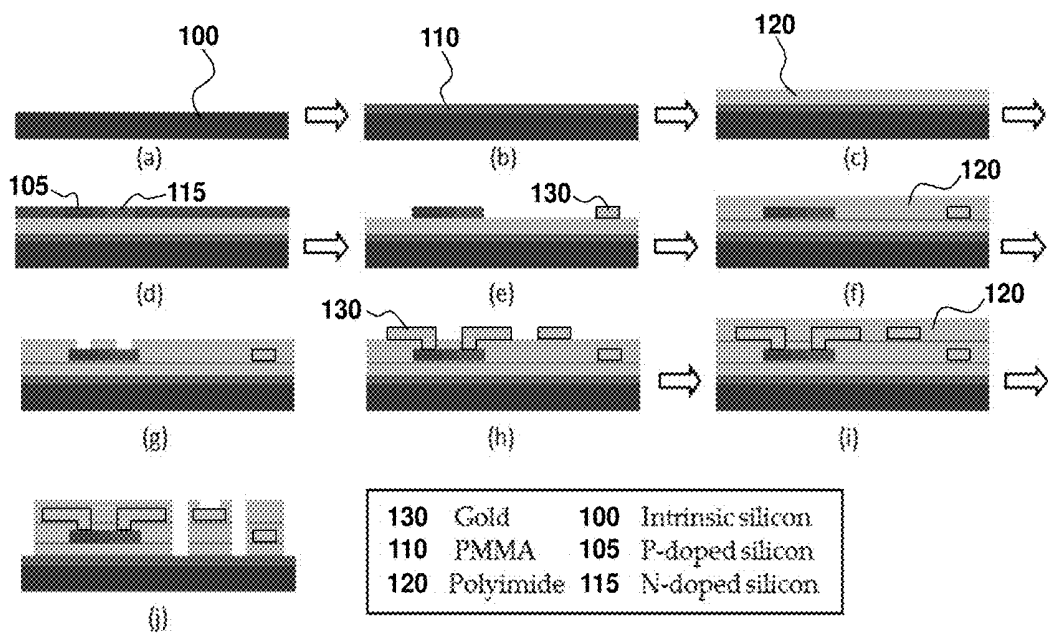

Figure 11

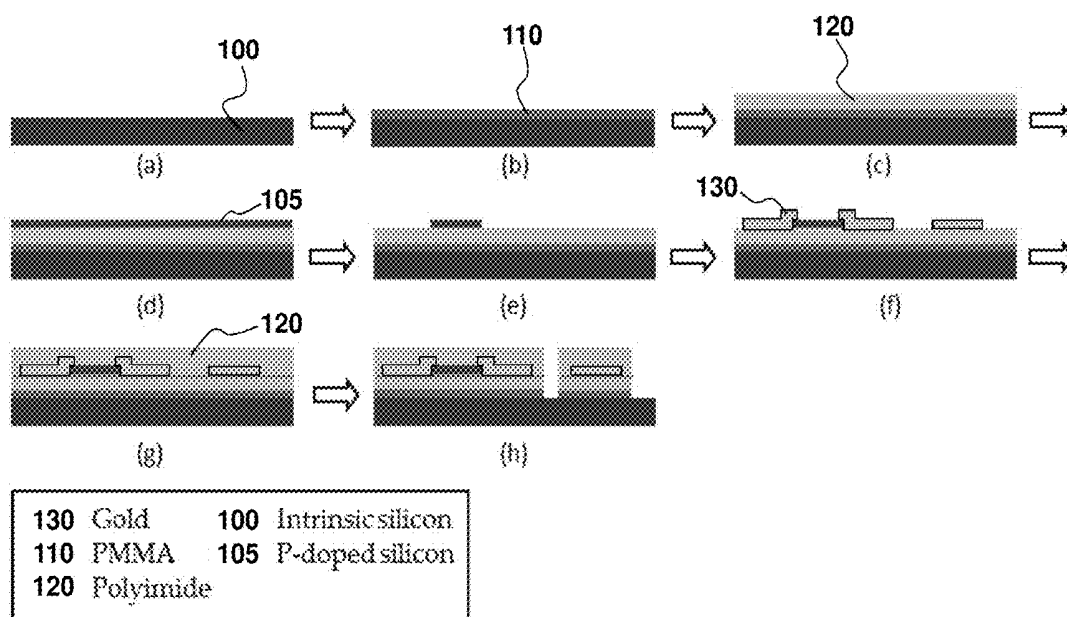

Figure 12

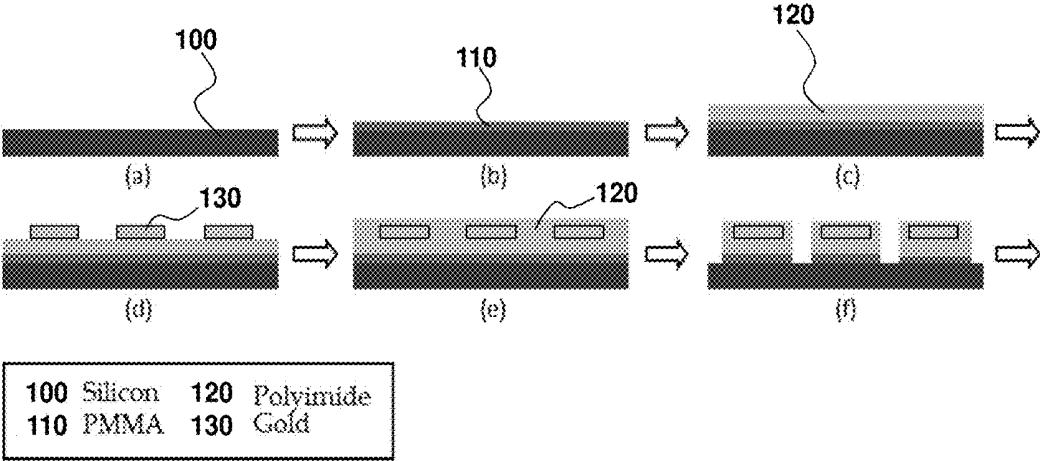

Figure 13

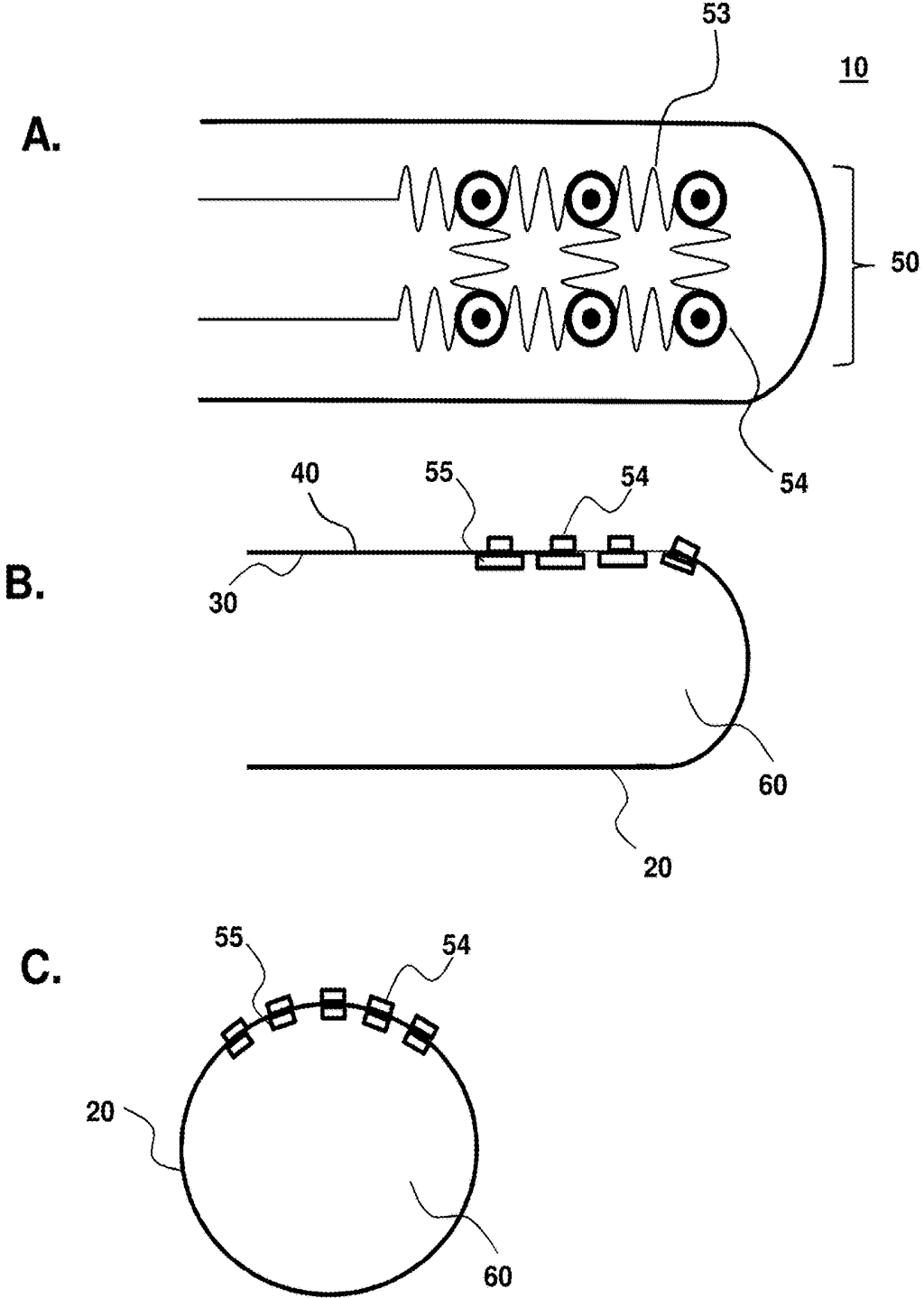

Figure 14

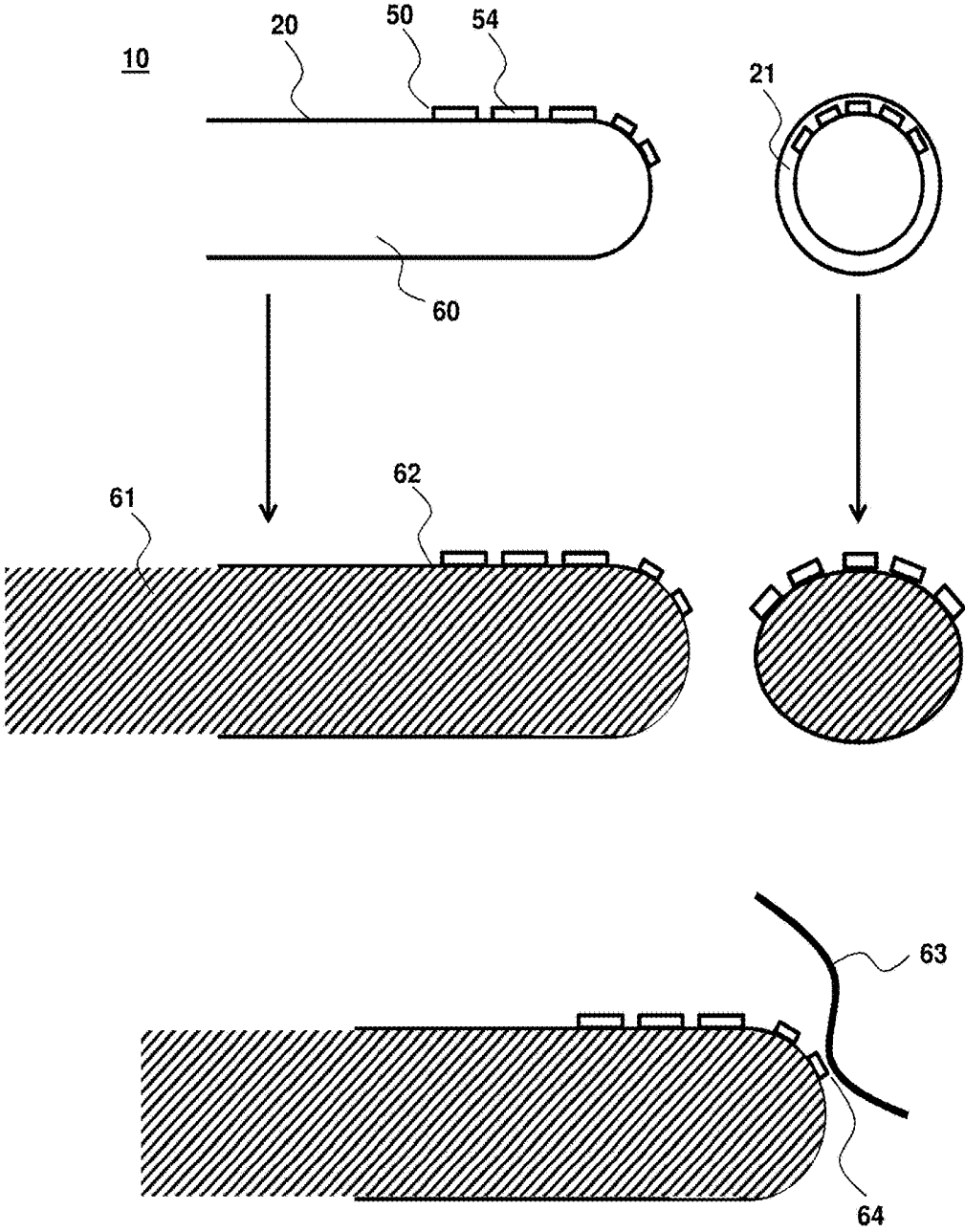

Figure 15

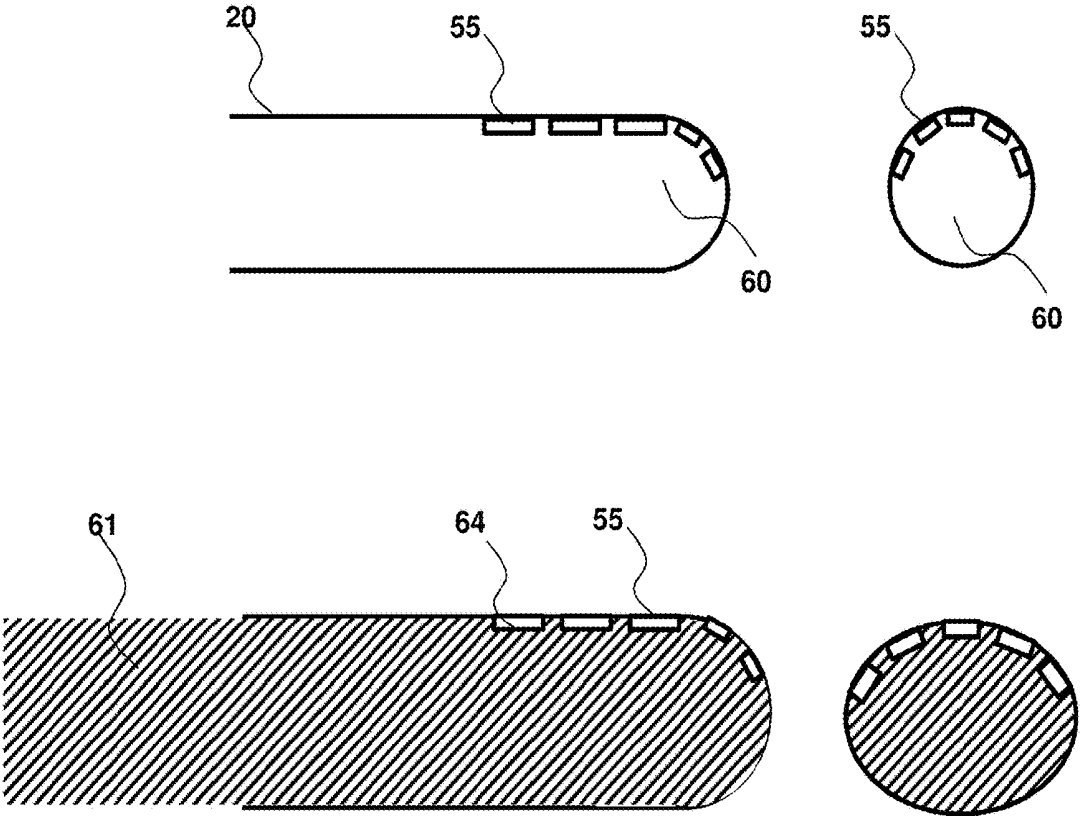

Figure 16

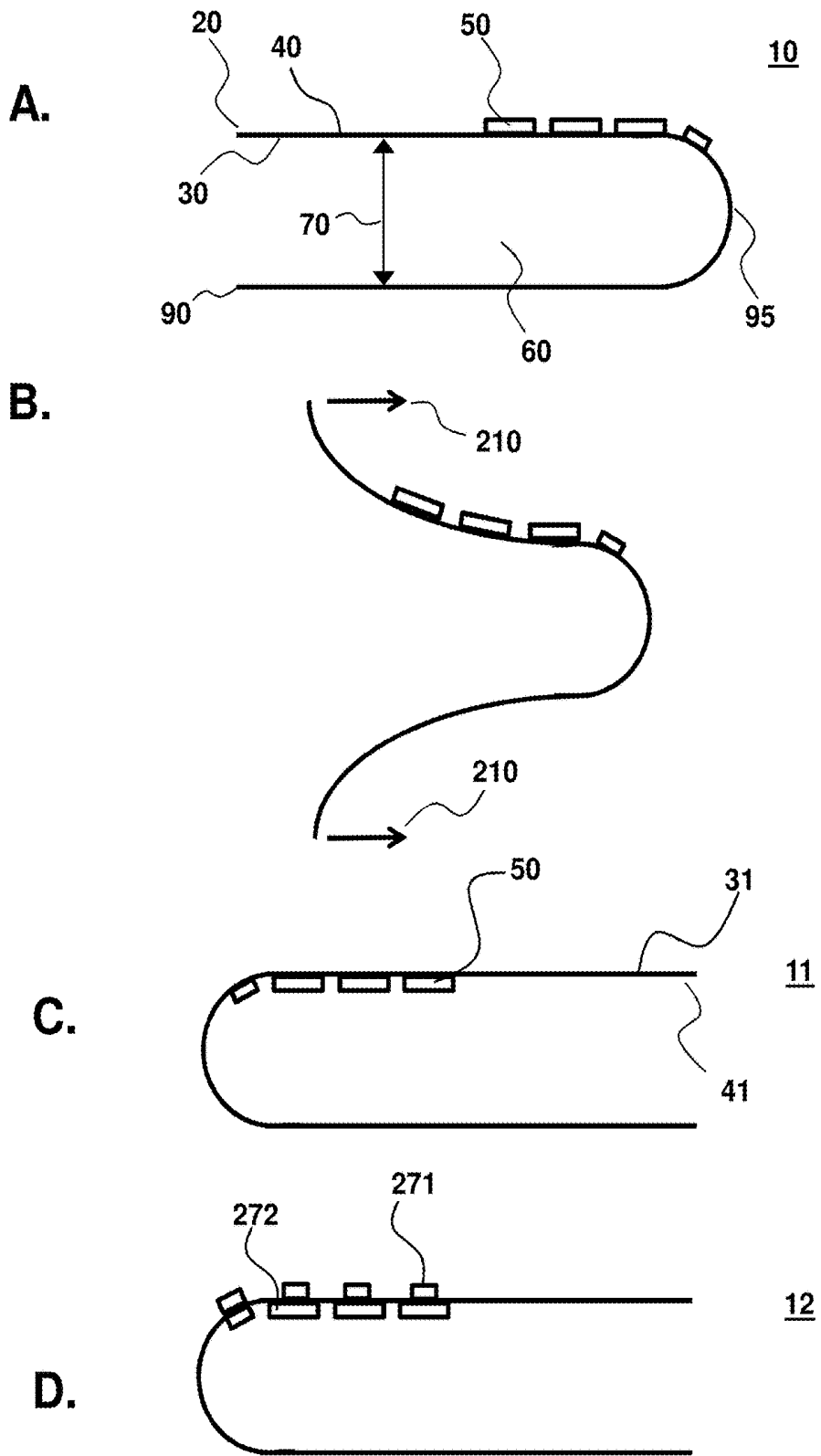

Figure 17

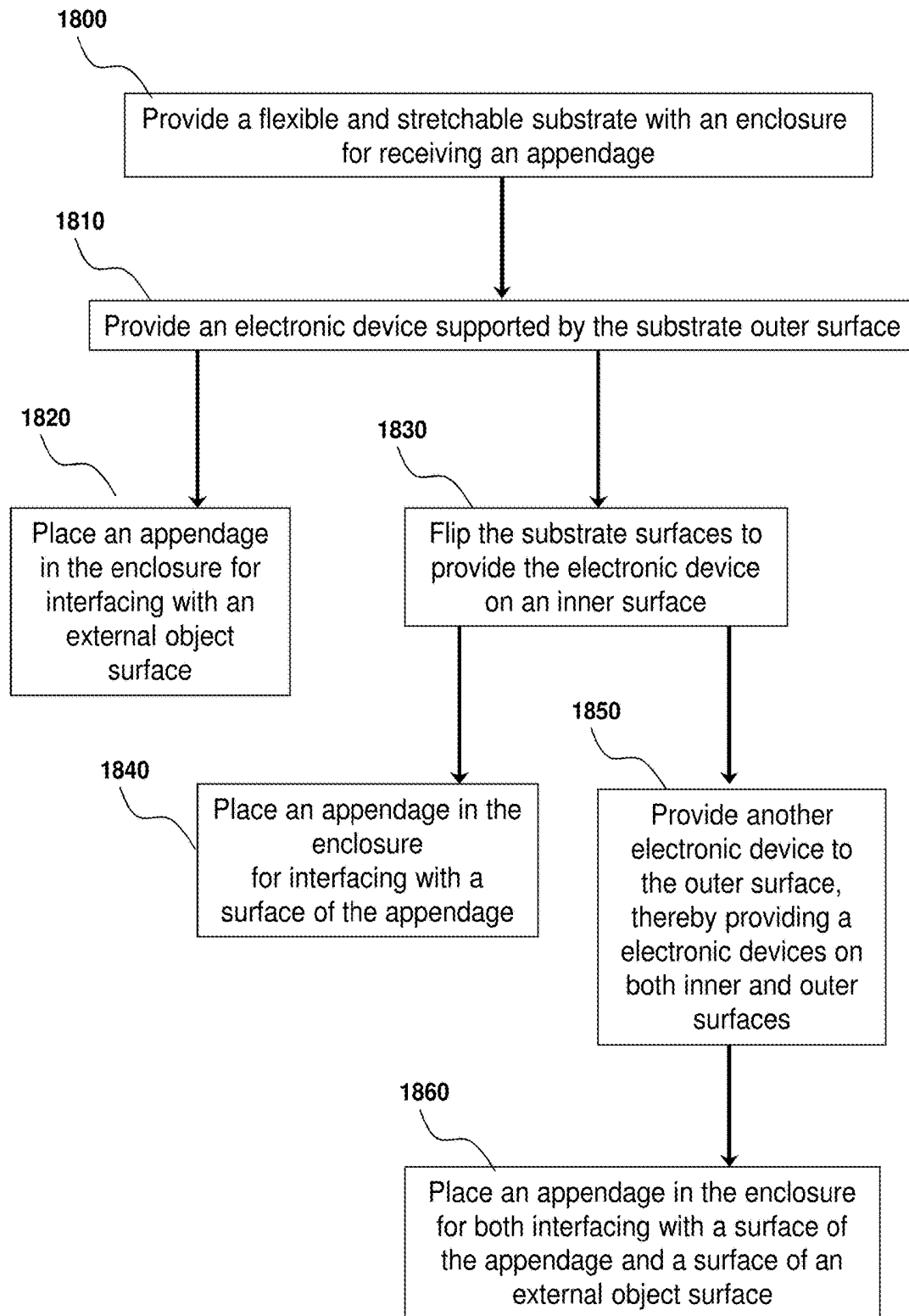

Figure 18

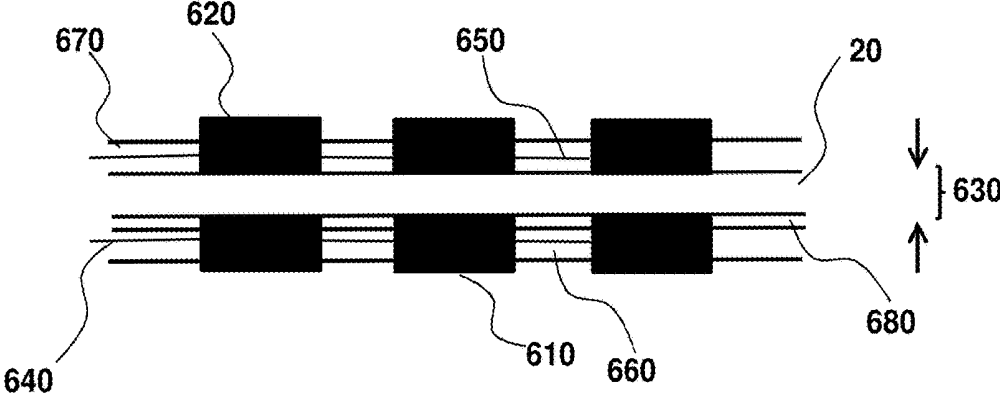

Figure 19

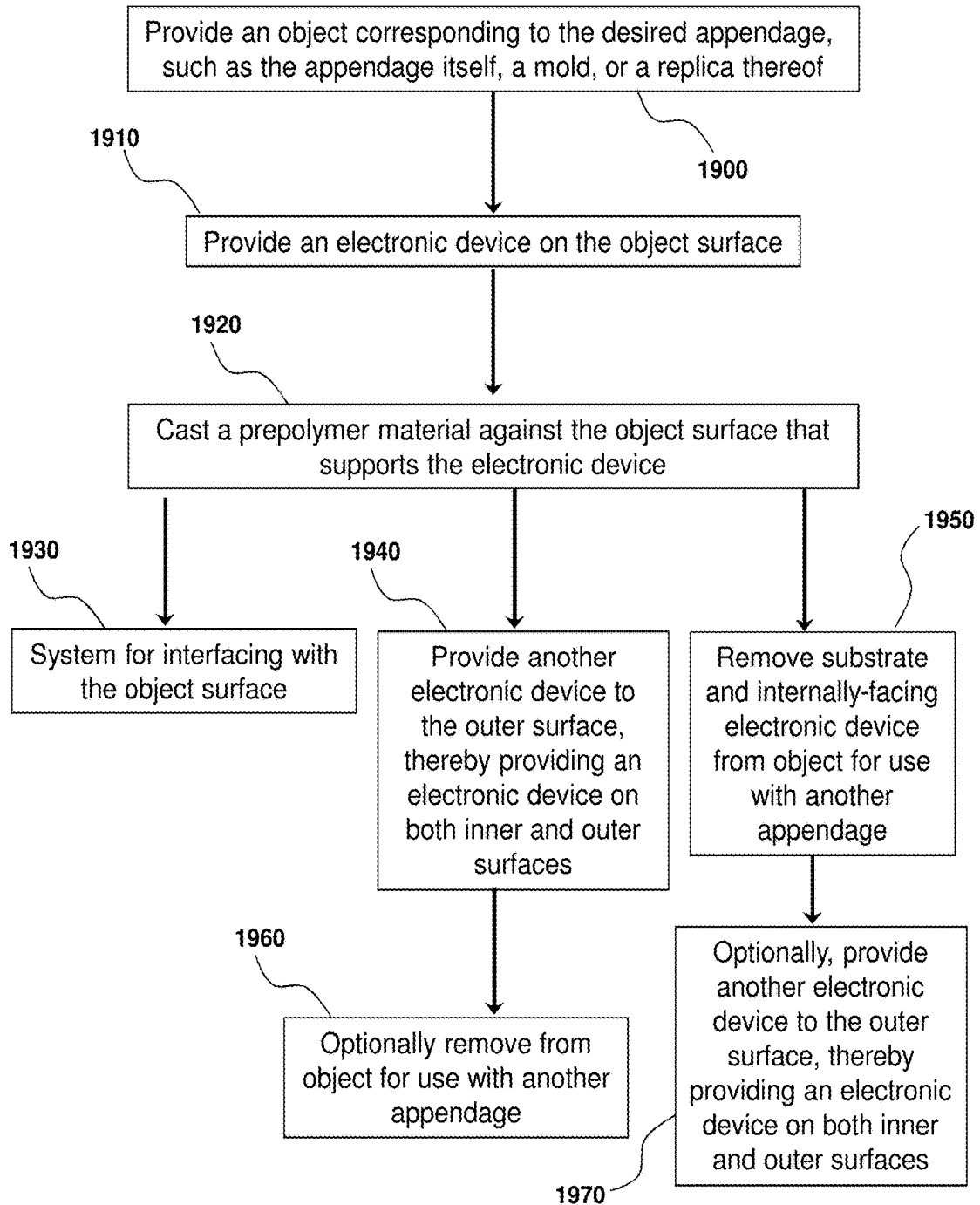

Figure 20

APPENDAGE MOUNTABLE ELECTRONIC DEVICES CONFORMABLE TO SURFACES

CROSS-REFERENCE TO RELATED APPLICATIONS

[0001] This application is a continuation of U.S. patent application Ser. No. 13/853,770 filed Mar. 29, 2013, which claims benefit to U.S. Provisional Patent Application Nos. 61/794,004 filed Mar. 15, 2013, 61/636,527 filed Apr. 20, 2012 and 61/618,371 filed Mar. 30, 2012, each of which are incorporated by reference to the extent not inconsistent herewith.

STATEMENT REGARDING FEDERALLY SPONSORED RESEARCH OR DEVELOPMENT

[0002] This invention was made with government support under CMMI-0328162 and awarded by the National Science Foundation, and DE-FG02-07ER46471 and DE-FG02-07ER46453 awarded by the Department of Energy. The government has certain rights in the invention.

BACKGROUND OF INVENTION

[0003] Physiological measurement and stimulation techniques that exploit interfaces to the skin have been of interest for many years. Despite much progress over this time, nearly all associated device technologies continue to rely on conceptually old designs. Typically, small numbers of bulk electrodes are mounted on the skin via adhesive tapes, mechanical clamps/straps and/or penetrating needles, often mediated by conductive gels, with terminal connections to separate boxes that house collections of rigid circuit boards, power supplies and communication components. These systems have many important capabilities, but they are poorly suited for practical application outside of research labs or clinical settings, due to difficulties in establishing long-lived, robust electrical contacts that do not irritate the skin, and in achieving integrated systems with overall sizes, weights and shapes that do not cause discomfort during prolonged use.

[0004] Recently, a number of patents and publications have disclosed flexible, resilient and implantable electrode arrays. For example, U.S. Patent Application Publication US 2007/0043416 discloses an implantable flexible elastic support with a plurality of electrodes held in contact with a target tissue. Similarly, International Patent Application Publication WO 98/49936 discloses a resilient electrode array for sensing signals associated (mapping) and ablating heart tissue. U.S. Pat. No. 5,678,737 discloses an electrophysiology mapping system for displaying a 3D model of epicardial and endocardial surfaces with dynamic display of potential distribution data.

[0005] U.S. Patent Application Publication US 2003/0149456 discloses a multi-electrode cardiac lead adapter which incorporates a multiplexing circuit allowing for control by a conventional single lead cardiac pacing pulse generator. Similarly, U.S. Patent Application Publication US 2006/0173364 discloses a multichannel electrophysiology acquisition system which utilizes a digital multiplexing circuit build on a conventional integrated circuit. U.S. Pat. No. 6,666,821 discloses an implantable sensor array system with an associated protective member which prevents the sensors from interacting with the surrounding environment until it is disabled.

[0006] International Application Publication WO 2009/114689 and U.S. Patent Publication No. 2013/0041235, each of which are individually hereby incorporated by reference in its entirety, discloses flexible and scalable sensor arrays for recording and modulating physiologic activity. US Patent Application Publication Nos. US 2008/0157235, US 2008/0108171, US 2010/0002402 and U.S. Pat. No. 7,557,367 issued Jul. 7, 2009, all of which are hereby incorporated by reference in their entirety, disclose multilayer stretchable, foldable and printable semiconductor devices.

[0007] There is a need in the art for high-fidelity, robust and reliable electronics on surfaces that are capable of accommodating any type of curved surface, including highly complex shapes such as those associated with moving fingers. One difficulty with providing electronics to interact with such complex surface shapes is that it can be difficult to reliably provide electronics in a correspondingly complex surface shape so as to achieve good interaction between the electronics and the complex surface shape over a large contact area. Provided herein are various devices and methods that address this aspect.

SUMMARY OF THE INVENTION

[0008] Provided herein are devices and methods related to ultrathin flexible and stretchable electronics that may be incorporated with flexible surfaces to permit electrical interfacing with a range of surfaces and surface shapes, including highly irregular shaped surfaces that may change shape over time. In an embodiment, the invention is an electronic device having an enclosure that is shaped to cover and conform to a curved surface, including a fully three-dimensionally varying surface having complex shapes with at least one surface that faces another surface, such as an appendage of a person that moves and changes shape with movement. Alternatively, the appendage may be part of a non-living instrument or inanimate object, such as a remote sensing device or robotic instrument.

[0009] In an aspect, the invention provides an appendage mountable electronic system, the system comprising: (i) a flexible or stretchable substrate having an inner surface and an outer surface, wherein the inner surface defines an enclosure capable of receiving an appendage having a curved surface; and (ii) a flexible or stretchable electronic device comprising one or more sensors, actuators or both supported by the inner surface or the outer surface of the flexible or stretchable substrate; the sensors, actuators or both comprising one or more inorganic semiconductor components, one or more metallic components, or one or more inorganic semiconductor components and one or more metallic components; wherein at least a portion of the inorganic semiconductor components, metallic components or both has a thickness less than or equal to 500 microns; wherein the flexible or stretchable substrate and the electronic device provide a net bending stiffness of the system low enough such that the inner surface of the substrate is capable of establishing conformal contact with a surface of the appendage provided within the enclosure. In an embodiment, for example, the appendage is a hand, a finger, a finger-tip, a skull, a foot, a toe, a leg, a torso, or any portion thereof. In an embodiment, for example, the system of the invention comprises an instrumented glove for covering a hand or an instrumented finger-tube for covering a finger or finger-tip, such as a medical glove for surgery. In an embodiment, for example, the system of the invention comprises a

human-machine interface system. In an embodiment, for example, the system of the invention comprises a device for robotic manipulation.

[0010] In an embodiment, for example, the flexible or stretchable substrate and the electronic device provide the net bending stiffness of the system less than or equal to 1×10^8 GPa μm^4 . In an embodiment, for example, the net bending stiffness of the device is low enough such that the one or more sensors, actuators or both supported by the inner surface of the substrate are capable of establishing conformal contact with the surface of the appendage provided within the enclosure. In an embodiment, for example, the flexible or stretchable substrate and the electronic device provide a net flexural rigidity of the system less than or equal to 1×10^{-4} Nm. In an embodiment, for example, the substrate is a flexible substrate and the electronic device is a flexible electronic device. In an embodiment, for example, the substrate is a stretchable substrate and device is a stretchable electronic device. In an embodiment, for example, the system is characterized by a neutral mechanical plane and wherein at least a portion of the one or more inorganic semiconductor components, or the one or more metallic components or both are positioned proximate to the neutral mechanical plane. In an embodiment, a strain-sensitive material, including the material having a mechanical property that is most sensitive to an applied strain, is positioned coincident or, alternatively, proximate to, the neutral mechanical plane.

[0011] Any of the systems provided herein may have from between about 2 to about 1000 of sensors, actuators or both. In an embodiment, the electronic device comprises at least 3 different types of sensors, actuators or both. In an aspect, the one or more sensors, actuators or both are provided in an open mesh geometry.

[0012] Any of the systems are optionally described in terms of a footprint surface area of the one or more sensors, actuators or both. In an embodiment, the footprint surface area is selected from the range of 0.5 cm^2 to 100 cm^2 . In an aspect, the footprint surface area corresponds to an array of sensors, actuators or both, wherein individual sensors or actuators have relatively small individual footprints, but the members of the array are spread to provide a desired footprint, including larger area footprints. Accordingly, depending on the application of interest, such as the surface area of the appendage being interfaced with, the footprint area is correspondingly selected. In this manner, a finger-tip appendage system may have a footprint surface area in the 0.5 cm^2 to about 2 cm^2 , whereas for an arm, leg, or head, the footprint surface area may be desirably larger such as 10 cm^2 to 100 cm^2 .

[0013] The systems provided herein are compatible with a large range of sensors, depending on the application of interest. Examples include one or more sensors selected from the group consisting of an electrode, a tactile sensor, a strain gauge, a capacitance sensor, a temperature sensor, a pressure sensor, a motion sensor, a position sensor, a displacement sensor, an acceleration sensor, a force sensor, a chemical sensor, a pH sensor, a capacitive sensor, an optical sensor, a photodetector, a hydration sensor, an imaging system and any arrays and combinations thereof.

[0014] The systems provided herein are compatible with a large range of actuators, depending on the application of interest. Examples include one or more actuators selected from the group consisting of an electro-tactile stimulator, an

electrode, a heat source (thermal actuator), a piezoelectric element, an acoustic element, a source of RF energy, a magnetic actuator, a source of electromagnetic radiation, a laser, a light source, a light emitting diode and arrays, and any arrays and combinations thereof.

[0015] In an embodiment, at least a portion of the sensors, actuators or both are supported by the inner surface of said flexible or stretchable substrate and at least a portion of the sensors, actuators or both are supported by the outer surface of the flexible or stretchable substrate. In an embodiment, an electronic device may be supported by both surfaces, such as a pressure sensor having aligned and paired electronic devices on both the internal and external surface that communicate with each other to provide an output that varies with separation distance between the electronic surfaces, such as by an applied pressure that changes thickness of a substrate that is elastomeric. In this manner, the devices may be electrodes that provide a measure of capacitance, a heat source and sensor that provide a measure of temperature, an optical source and optical detector that provides a measure of a light property, such as optical intensity. The common aspect of these systems is that the output of the device depends on substrate thickness between the devices, which in turn depends on the applied pressure or force. In this manner, the system provides a unique platform for pressure or force measurement with an external surface.

[0016] In an embodiment, the electronic device comprises a plurality of electro-tactile stimulators provided in an array and supported by said the surface of the substrate for electrically stimulating an appendage in the enclosure. In an aspect, the functional electronic device comprises a multiplexed array of said electro-tactile stimulators. In an aspect, the electro-tactile stimulators of the array are electrically interconnected via a network of serpentine electrical interconnects.

[0017] In an aspect, any of the electro-tactile stimulators provided herein comprise a thin film metal structure having an inner region surrounded by an outer region, wherein a gap is provided between the inner region and the outer region. Such regions are optionally described in term of their dimensions. Examples include an inner region having lateral dimensions selected from the range of $10 \mu\text{m}$ to $1000 \mu\text{m}$, an outer ring having lateral dimensions selected from the range of $10 \mu\text{m}$ to $5000 \mu\text{m}$ and a gap having lateral dimensions selected from the range of $10 \mu\text{m}$ to $1000 \mu\text{m}$.

[0018] In an embodiment, the inner region is a conductive disk-shaped electrode and the outer region is a conductive ring-shaped electrode positioned concentric with said disk-shaped electrode.

[0019] In an embodiment, the electronic device comprises a plurality of tactile sensors provided in an array and supported by the outer surface, inner surface, or both the outer and inner surface of the substrate. In an aspect, the electronic device comprises a multiplexed array of tactile sensors. Paired electronic devices aligned but on opposite elastomeric substrate surfaces provide one means for measuring a pressure or force exerted by or against any of the systems provided herein.

[0020] In an embodiment, the tactile sensors of the array are electrically interconnected in independently connected via a network of serpentine electrical interconnects.

[0021] In an aspect each of the tactile sensors comprises a thin film metal structure having lateral dimensions selected

from the range of 100 μm to 5000 μm . In one example, the thin film metal structure of the tactile sensors is a conductive disk-shaped electrode.

[0022] In another embodiment the electronic device comprises one or more tactile sensors supported by the outer surface and one or more electro-tactile stimulators supported by the inner surface, wherein one or more tactile sensors are in electrical communication with one or more electrotactile stimulators such that an output from the one or more tactile sensors is provided to the one or more electrotactile stimulators to electrically stimulate the appendage in proportion to the tactile sensor output. In one aspect, the inner surface and outer surface arrays are spatially aligned. "Spatially aligned" refers to an output from the sensor array that spatially varies, with the magnitude of sensor output that varies with position of the sensor, and the corresponding stimulation to the appendage that correspondingly spatially varies in accordance with the spatially varying output from the sensors.

[0023] In an aspect, electronic device comprises a plurality of electrodes, each electrode comprising an inner disk having a diameter that is less than 1 mm; and an outer ring that surround the inner disk, wherein the inner disk and outer ring are concentrically positioned relative to each other, with a separation distance between the inner disk and outer ring selected from a range that is greater than or equal to 100 μm and less than or equal to 500 μm .

[0024] As desired, any of the systems optionally further comprise one or more additional electronic components supported by the inner surface, the outer surface or both; the additional electronic components selected from the group consisting of a sensor, an actuator, a power source, a wireless power source, a photovoltaic device, a wireless transmitter, an antenna, a nanoelectromechanical system, a microelectromechanical system and arrays and any combinations thereof. In an aspect, the one or more additional electronic components comprise a strain gauge, such as a strain gauge comprising one or more semiconductor nanomembranes.

[0025] In an embodiment, each semiconductor nanomembrane independently has lateral dimensions selected from the range of 1 μm to 10 mm and a thickness selected from the range of 100 nm to 100 μm .

[0026] In an aspect, the strain gauge comprises a plurality of at least three electrically connected semiconductor nanomembranes.

[0027] In an aspect, the semiconductor nanomembranes are electrically interconnected via a network of serpentine electrical interconnects.

[0028] In an embodiment, any of the systems provided herein comprise one or more inorganic semiconductor components, such as each of the one or more inorganic semiconductor components independently comprising a polycrystalline semiconductor material, single crystalline semiconductor material or a doped polycrystalline or single crystalline semiconductor material.

[0029] In an aspect, each of the one or more inorganic semiconductor components independently comprises a single crystalline semiconductor material. In an aspect, each of the one or more inorganic semiconductor components independently has a thickness that is less than or equal to 100 μm . In an aspect, each of the inorganic semiconductor components of the electronic device have a thickness selected from the range of 50 nanometers to 100 μm . In an aspect, each of the inorganic semiconductor components of the electronic device has a net flexural rigidity less than or

equal to 1×10^{-4} Nm, a Young's modulus selected from the range of 0.5 MPa to 10 GPa, a net bending stiffness less than or equal to 1×10^8 GPa μm^4 .

[0030] In an embodiment, each of the one or more inorganic semiconductor components independently comprises a semiconductor nanomembrane structure, such as a nanomembrane structure that is a diode electronic component.

[0031] In another aspect, any of the systems provided herein comprise one or more metallic components. In an aspect, the one or more metallic conductor components comprise a plurality of electrodes provided in an array.

[0032] In an embodiment, any of the metal electrodes provided herein, such as within an array, are described in terms of a thickness. In an aspect, the electrodes in an array independently have a thickness less than or equal to 100 μm , or selected from the range of 50 nanometers to 100 μm . In an embodiment, the number of electrodes in an electrode array is selected from a number that is between 10 to 10,000 electrodes.

[0033] In an aspect, the electrodes of the array are electrically interconnected via a network of serpentine electrical interconnects.

[0034] In an embodiment, any of the systems provided herein have the one or more sensors, actuators or both of the electronic device comprises a stretchable or flexible electrode array comprising a plurality of electrodes, multiplex circuitry and amplification circuitry. In an aspect, the stretchable or flexible electrode array comprises a plurality of electrode unit cells, such as 50 or more electrode unit cells. Optionally, adjacent electrode unit cells of the electrode array are further described in terms of a separation distance, such as adjacent unit cells separated from each other by a distance less than or equal to 50 μm , or a range between 500 nm and 50 μm . In an embodiment, the electrode unit cells of the electrode array are supported by an area of the flexible or stretchable substrate ranging from 10 mm^2 to 10,000 mm^2 .

[0035] In an aspect, each electrode unit cell of the electrode array comprises a contact pad, amplifier and multiplexer, wherein the contact pad provides an electrical interface to the tissue and is in electrical communication with the amplifier and multiplexer. In an embodiment, the amplifier and multiplexer of the unit cell comprises a plurality of transistors.

[0036] Any of the one or more metallic conductor components herein comprise a plurality of stretchable electrical interconnects. Optionally, the stretchable electrical interconnects are at least partially free-standing or provided in a tethered geometry. Optionally, the stretchable electrical interconnects have a curved geometry. Optionally, the electrical interconnects have a serpentine configuration. Optionally, the stretchable electrical interconnects electrically connect rigid device islands comprising at least a portion of the one or more one or more inorganic semiconductor components, one or more metallic components, or one or more inorganic semiconductor components and one or more metallic components.

[0037] In an aspect, at least a portion of the rigid device islands each independently comprise a single crystalline inorganic semiconductor structure, or a single crystalline semiconductor nanomembrane.

[0038] In an aspect, the rigid device islands comprise the one or more sensors, actuators or both, such as sensors or actuators selected from the group consisting of: an electrode,

a tactile sensor, a strain gauge, a capacitance sensor, a temperature sensor, a pressure sensor, a motion sensor, a position sensor, a displacement sensor, an acceleration sensor, a force sensor, a chemical sensor, a pH sensor, a capacitive sensor, an optical sensor, a photodetector, an imaging system, an electrotactile stimulator, an electrode, a heat source, a piezoelectric element, an acoustic element, a source of RF energy, a magnetic actuator, a source of electromagnetic radiation, a laser, a light emitting diode and arrays and any arrays and combinations thereof.

[0039] Any of the systems provided herein may have at least a portion of the flexible or stretchable electronic device supported by either the outer surface, by the inner surface of the flexible or stretchable substrate, or by both surfaces. In an aspect, the inner surface and outer surface are interchangeably flippable without substantial degradation of a functionality parameter of the one or more sensors, actuators or both supported by the inner surface or the outer surface of the flexible or stretchable substrate.

[0040] For example, a system comprising an array of actuators, sensors, or actuators and sensors, is interchangeably flippable between inner and outer and inner configurations without substantial degradation of a functionality parameter of the array of actuators, sensors, or actuators and sensors. In an aspect, the flipping facilitates placement of electronic devices on an inner surface that is otherwise not accessible or amenable to conventional printing techniques. In an embodiment, the outer surface that supports the electronic device is flipped, so that after flipping the functional electronic device supported by the outer surface is the functional electronic device supported by the inner surface. In an embodiment, the functional electronic device is an array of electrotactile stimulators, and at least 90% of the electrotactile stimulators remain functional after flipping from an outer facing surface to an inner facing surface geometry.

[0041] In an aspect, the flexible or stretchable substrate has a closed tube geometry. In an embodiment, the closed tube geometry has one access opening or two access openings.

[0042] In an aspect, the enclosure has cross sectional dimensions selected from the range of 5 mm to 1000 cm. Depending on the application of interest, the cross sectional dimensions are appropriately selected. For example, fingertip electronics may have a smaller cross sectional dimension than a torso or a head electronics system, which may be smaller than a remote sensing vehicle or instrument surface connected thereto.

[0043] In an embodiment, any of the flexible or stretchable substrates provided herein is an elastomeric substrate.

[0044] In an aspect, the flexible or stretchable substrate is a polymer, an inorganic polymer, an organic polymer, a plastic, an elastomer, a biopolymer, a thermoset, rubber, or any combination of these. In an aspect, the flexible or stretchable substrate is PDMS, parylene, polyimide, or silicone such as Ecoflex® (Smooth-On, Inc.) silicone. In an aspect, the flexible or stretchable substrate is a biocompatible material or a bioinert material.

[0045] In an embodiment, the flexible or stretchable substrate has an average thickness selected over the range of 0.25 μm to 10,000 μm , including any sub-combination thereof, such as between about 1 μm and 5 mm, or about 1 mm.

[0046] In an aspect, the flexible or stretchable substrate has a substantially uniform thickness supporting the electronic device or has a thickness supporting the electronic device that varies selectively along one or more lateral dimensions. In this context, “substantially uniform” refers to a substrate at rest having a thickness that varies less than about 10%, less than about 5% or less than about 1%. Alternatively, substantially uniform may refer to a substrate that has received an appendage in the enclosure, having a thickness that varies less than about 10%, less than about 5% or less than about 1%. Optionally, substantially uniform refers to a statistical parameter, such as a standard deviation or standard error of the mean of an average thickness that is within about 10%, 5% or 1% of the average thickness over a selected portion of the substrate, or over the entire substrate surface area.

[0047] In an embodiment, the flexible or stretchable substrate is a flexible or stretchable mesh structure. In an embodiment, at least a portion of the electronic device has a mesh structure. Examples of mesh structures include open mesh geometries where a substantial portion of the relevant is open space or void, such as for longitudinally aligned interconnects which may be curvy but have a general alignment direction. Similarly, longitudinally arranged strips of substrate may be provided such as to provide additional breathability to an appendage to which the system is mounted. Alternatively, the substrate may have perforations or passages. This mesh aspect may be defined in terms of relative amount of open space compared to the perimeter-defined substrate footprint, such as between about 10% to 90%, and any subranges thereof, such as between 20% to 80%, 30% to 70%, depending on the application of interest.

[0048] In an aspect, the flexible or stretchable substrate has an average Young's modulus selected over the range of 0.5 KPa to 10 GPa and/or a fracture strain greater than or equal to 500%, such as between about 500% and 900%.

[0049] Any of the systems provided herein may further comprise a barrier layer at least partially encapsulating at least a portion of the functional device. For example, the barrier layer may limit a net leakage current from the electronic device to an amount which does not adversely affect a material in contact with the system or limits a heat transfer from the electronic device to an amount which does not adversely affect a material in contact with the system. This can be particularly beneficial in the context of biological systems that may be adversely affected by electrical or thermal leakage, such as an biological tissue covering an appendage within the enclosure.

[0050] The barrier layer may also substantially prevent passage of an external fluid to at least a portion of the electronic device. This may be beneficial to maintain electronic device functionality, robustness, and long-term wear characteristics.

[0051] In an embodiment, the barrier layer is a polymer, an inorganic polymer, an organic polymer, a plastic, an elastomer, a biopolymer, a thermoset, rubber or any combination of these. In an embodiment, the barrier layer is PDMS, parylene, polyimide, or Ecoflex®. In an embodiment, the barrier layer comprises a composition that corresponds to the flexible or stretchable substrate.

[0052] In an aspect, the barrier layer has an average thickness selected from the range of 1 μm to 100 μm , an average modulus selected over the range of 0.5 KPa to 10 GPa. Optionally, the barrier layer is described by a ratio of

the average thickness of the barrier layer to the average thickness of the flexible or stretchable substrate, such as a ratio that is selected over the range of 0.01 to 1. Depending on the specific application, the barrier layer is positioned as desired. Examples of positions include between otherwise adjacent device layers and/or between a device layer and the surrounding environment such as the appendage, air, or an external surface. In an aspect, the barrier layer has a mesh structure.

[0053] In an embodiment, the system further comprises one or more stretchable interconnects that electrically connect at least a portion of said one or more sensors, actuators or both. Such stretchable interconnects may be configured to impart stretchability and/or flexibility to the system. Any of the one or more stretchable interconnects comprises an electrically conductive metal provided in a bent configuration.

[0054] Bent configuration is used broadly and may include a nanowire in a serpentine configuration. The nanowire may have a rectangular cross-section, with a thickness selected from the range of 50 nm to 1 μm and a width that is selected from the range of 10 μm to 1 mm. The serpentine configuration may be meandering undergoing a plurality of directional changes relative to an average longitudinal direction defined by a straight line between the interconnect ends. In an aspect, the serpentine configuration is characterized by an average radius of curvature selected from the range of 100 μm to 10 mm.

[0055] In an aspect, the system comprises a plurality of interconnects arranged in at least two interconnect layers, with adjacent interconnect layers separated by a barrier layer that is an electrically insulative elastomeric layer. This configuration facilitates compact overlying interconnect wiring. In an aspect, the electronic devices comprise rigid device islands electrically connected to at least one interconnect, wherein the interconnect bent configuration accommodates stresses from bending and stretching of the thin elastomeric substrate. In an aspect, the bending and stretching stresses are from flipping the inner and outer surfaces of the flexible or stretchable substrate.

[0056] In an aspect, the system has a neutral mechanical plane (NMP), that is positioned at a depth that corresponds to a depth of a strain-sensitive component. For example, the NMP may run along a surface defined by or within the strain-sensitive components, such as a strain sensitive component that is a semiconductor or metal material. Optionally, NMP positioning is by providing substrate or barrier layers, including by varying the thickness of those layers.

[0057] In an aspect, at least a portion of the one or more inorganic semiconductor components, one or more metallic components or both are printable structures. In an embodiment, at least a portion of the one or more sensors, actuators or both are assembled on the flexible or stretchable substrate via transfer printing. In an embodiment, at least a portion of the one or more sensors, actuators or both are assembled on said flexible or stretchable substrate via microtransfer printing, dry contact transfer printing, solution-based printing, soft lithography printing, replica molding, or imprint lithography.

[0058] In an embodiment, the enclosure has an interior volume and at least one opening for receiving and covering an appendage. In an aspect, the enclosure interior volume that is greater than or equal to 1 cm^3 and less than or equal to 10,000 cm^3 .

[0059] In an aspect, the enclosure has a shape, such as a substantially cylindrical or hemispherical shape. In an aspect the enclosure is shaped to receive a hand, a finger, a finger-tip or any portion thereof.

[0060] In an embodiment, the enclosure has one or two access openings for receiving the appendage, such as one opening to receive an appendage that is a finger or a head portion, or two openings to receive an arm, leg, or torso, wherein a portion of the appendage extends through the enclosure first and second access openings.

[0061] In an aspect, the flexible or stretchable substrate wraps around the appendage under a longitudinally-directed tension or is rolled over the appendage under a circumferentially-directed tension.

[0062] In an embodiment, the appendage is part of a living animal, such as a finger, an arm, a leg, a head, a torso, or any portion thereof.

[0063] In an aspect, any of the systems provided herein relate to first and second electronic devices supported by opposing surfaces, such as inner and outer surfaces, wherein the devices are in communication with each other. Depending on the type of device, the communication is characterized by a parameter, such as an electrical parameter (capacitance) or thermal (temperature), that varies with substrate thickness between the devices. Preferably, the substrate is elastomeric. In this manner, a pressure sensor is provided, wherein the communication parameter depends on substrate thickness, which in turn depends on the applied force or pressure exerted on the substrate.

[0064] In an aspect, the enclosure has a receiving dimension that is smaller than a corresponding dimension of the appendage, wherein during use a strain in the flexible or stretchable substrate increases the receiving dimension to accommodate the appendage within enclosure without adversely impacting the flexible or stretchable electronic device. In an embodiment, the strain generates a contact force between the elastomeric substrate and the appendage within the enclosure to establish and maintain intimate and conformal contact between the flexible or stretchable electronic device supported by the substrate inner surface and a surface of the appendage. In an aspect, the strain is selected from a range that is greater than or equal to 1% and less than or equal to 100%.

[0065] In an embodiment, the array of sensors, actuators or both, are described in terms of a spatial density, such as a spatial density selected from a range that is between about 1 mm^{-2} and 1 cm^{-2} .

[0066] In an aspect, any of the systems are multifunctional, wherein the inner surface supports a first array of actuators or sensors, and the outer surface supports a second array of sensors or actuators. In an embodiment, the first array comprises electrotactile stimulators to interface with skin of a living animal in conformal contact with the electronic devices of the first array, and the second array comprises tactile sensors to measure a physical parameter from tactile interaction with an external surface. In an aspect, the tactile sensor comprises opposing electrodes on the inner and the outer surfaces to measure a capacitance between the electrodes, wherein the capacitance varies with substrate thickness between the opposing electrodes.

[0067] In an aspect, the inner surface supports a first electronic device and the outer surface supports a second electronic device, wherein the electronic devices are in an opposed configuration and in communication with each

other, wherein they form, for example, a pressure sensor. In an aspect, the communication is electrical communication (capacitance) wherein an electrical property varies with substrate thickness between the first and second opposed electronic devices. In an aspect, the devices are in thermal communication, wherein a thermal property changes with substrate thickness between the opposed electronic devices. In an aspect the devices are in mechanical communication (pressure or force).

[0068] In an embodiment, the first and second electronic devices are in thermal communication with each other. For example, one electronic device may be a heater and a second electronic device may be a thermal sensor, with the heater placed on an inner or outer surface and the thermal sensor on the opposite surface, wherein the heater can maintain a constant temperature on its support surface. In this manner, the thermal communication between the heater and sensor is used to assess a pressure or force exerted against a substrate whose thickness varies depending on the magnitude of the pressure or force applied against the substrate. Generally, with higher applied pressures, substrate thickness decreases thereby increasing thermal conductivity from the heater to the sensor which is detected by an increase in the temperature detected by the thermal sensor. In an aspect, the heater is a resistive heater whose temperature increases with increasing current, such as by electrically conductive wires connected to a heating pad. In an aspect where the appendage is living tissue, preferably the heater is placed on the outer surface to avoid unwanted heating of the living tissue. Accordingly, the thermal sensor may be aligned with the heater on an inner surface. In an aspect, the system may be calibrated by the use of an unpaired thermal sensor to adjust for fluctuations in ambient temperature. Alternatively the communication may be optically, between an optical source and optical detector, wherein optical transmission varies as a function of substrate thickness between source and detector.

[0069] In an aspect, a sensor is provided on the inner surface of any of the systems described herein. The sensor or sensors may be one or more of a thermal sensor to measure body temperature including as a measure of body core temperature, a hydration sensor to measure hydration levels including as a measure of whole body hydration, or another sensor to detect a biological parameter of interest (e.g., pH, oxygenation level, etc.). Such measures are useful in providing warning about potential risk of an adverse event, such as heat-stroke or dehydration.

[0070] In an embodiment, the first and second electronic devices are in electrical communication with each other, wherein change in substrate thickness changes electrical capacitance or electrical resistance between the electronic devices. In this manner, pressure or force is determined by measuring capacitance between a pair of aligned electrodes on the inner and outer surfaces. In an aspect, the second array of sensors generates an electrical output that is input to the first array of actuators, wherein the first array of actuators interface with the appendage surface that is skin of a user to provide information to the user about the external surface. In this context, "information" refers to a property that is detected by the sensor, and so accordingly, can be a physical property such as contact force or pressure generated by surface contact or a property inherent to an external surface, such as temperature, pH, hydration, or presence of a chemical or biological material.

[0071] An example of an appendage mountable electronic system includes: (i) an elastomeric substrate having an inner surface and an outer surface, wherein the inner surface defines an enclosure capable of receiving an appendage having a curved surface; (ii) a first electronic device supported by the inner surface; (iii) a second electronic supported by the outer substrate, wherein the first and second electronic devices are in an opposed configuration with respect to each other and separated by a thickness of the elastomeric substrate to form a functional pressure sensor whose output varies as a function of elastomeric substrate thickness; wherein each of the first and second electronic devices may comprise a thin electrically conductive material having a thickness less than 1 mm and a lateral dimension less than 5 mm and the elastomeric substrate has a resting thickness that is less than 10 mm to for an output that is capacitance when an electrode is energized.

[0072] In another embodiment, the appendage mountable electronic system comprises: an elastomeric substrate having an inner surface and an outer surface, wherein the inner surface defines an enclosure capable of receiving an appendage having a curved surface, and the elastomeric substrate has a resting thickness that is less than 10 mm; a first electronic device supported by the inner surface; a second electronic device supported by the outer substrate, wherein the first and second electronic devices are in an opposed configuration with respect to each other and separated by a thickness of the elastomeric substrate to form a pressure sensor whose output varies as a function of elastomeric substrate thickness; each of the first and second electronic devices comprises one or more inorganic semiconductor components, one or more metallic components, or one or more inorganic semiconductor components and one or more metallic components, having a thickness less than 1 mm and a lateral dimension less than 5 mm.

[0073] In an aspect, the system further comprises a first plurality of electrical interconnects to electrically connect each member of the array of first electrodes and a second plurality of electrical interconnects to electrically connect each member of the second array of electrodes, wherein the electrical interconnects are in a serpentine configuration. The electrical interconnects may be independently encapsulated by an encapsulation layer. A barrier layer may electrically isolate the first plurality of electrical interconnects from the second plurality of electrical interconnects. An applied pressure to the elastomeric substrate decreases substrate thickness between the pair of electrodes, thereby increasing the capacitance. Another example is first and second electronic devices that are in thermal communication with each other, wherein one of the electronic devices is a thermal source and the electronic device is a thermal detector that measures a temperature, and a change in elastomeric substrate thickness between the thermal source and the thermal detector changes the temperature measured by the thermal detector.

[0074] The systems discussed herein are also referred to as an "appendage mountable electronic system" or "appendage conforming system", and may comprise a thin flexible and/or stretchable substrate having an inner surface and an outer surface. The substrate inner surface defines an enclosure for receiving a curved surface (e.g., an appendage surface), such as by covering and conformally contacting the surface associated with an appendage in the enclosure. Optionally, the substrate is described in terms of a thickness,

such as a thickness that is less than 10 mm, a thickness that is less than 1 mm, a thickness that is less than 500 μm , or a thickness selected over a range that is greater than or equal to 100 μm and less than or equal to 1 mm. Thickness may be selected based on the operating conditions and relevant application. For example, in applications having substantial surface abrasion, the substrate may be correspondingly thicker and/or have higher durability characteristics. A functional electronic device is supported by the elastic substrate inner surface or the elastic substrate outer surface. The functional electronic device comprises a device component that is one or more inorganic semiconductor components, one or more metallic components, or one or more inorganic semiconductor components and one or more metallic components. The functional electronic device, including any device components thereof, is stretchable and bendable. The functional electronic device, including any device components thereof, have a thickness, such as a thickness that is less than or equal to 10 μm . The thin lay-out geometry of the devices and the properties of the elastomeric substrate provide a number of functional benefits in terms of the interaction between object surfaces and the electronic device, and also to facilitate certain unique transfer printing processes for making any of the devices herein.

[0075] For example, the inner surface of the substrate may be visually and/or physically inaccessible in that the three-dimensional shape of the enclosure is a closed surface that defines an interior volume. Such an enclosure, particularly if small, is difficult to access, making it difficult to place functional electronic devices on the enclosure surface. Although such an enclosure may have one or two openings, it still may not be readily accessible for transfer printing of functional electronic devices, in comparison to an open enclosure having a free end that may be used to open the enclosure to transfer printing. The elastomeric substrate properties of the instant invention allow for the specially configured functional electronic devices on an outer surface to be flipped so that functional electronic devices are on the inner surface defining the enclosure. This is achieved by the special configured thin device component layouts and correspondingly thin functional electronic device, that can be substantially stretched, bent, and/or folded without adversely impacting device functionality. Accordingly, an aspect of the instant invention relates to an inner surface that is not physically accessible to conventional electronic device transfer printing processes. The outer surface of any of the substrates discussed herein, in contrast, faces away from the interior and is visually and physically accessible with no or minimal applied force. For example, the outer surface may have invaginations that become physically accessible by a relatively straight-forward minimal force application to stretch the substrate and remove invaginations or folds over a desired region. Transfer printing functional electronic device arrays to the outer surface, followed by substrate surface flipping, facilitates placement of functional electronic device and arrays in extremely confined interior volumes and enclosures not otherwise accessible to conventional transfer printing techniques.

[0076] In an embodiment, any of the substrates in any of the devices and methods provided herein, has an inner and outer surface that are interchangeably flippable without substantial degradation of a functionality parameter of the functional electronic device supported by the inner surface or the outer surface. In this embodiment, it does not matter

which surface supports the functional electronic device, as the substrate surfaces can be readily flipped so that an outward facing electronic device can be flipped inward by flipping the substrate surfaces. Similarly an inward facing electronic device can be flipped outward by flipping the substrate surfaces. Accordingly, in an aspect, the elastomeric substrate material and the attached functional electronic devices, are selected so as to have appropriate physical characteristics to allow flipping without adversely impacting the substrate integrity or device functionality. For example, the material may have a relatively low modulus, such as less than 1 MPa, less than 500 kPa, less than 100 kPa, or selected from a range that is greater than or equal to 10 kPa and less than or equal to 200 kPa. Similarly, the substrate may have a relatively high fracture strain, such as a fracture strain that is greater than or equal to about 200%, 500%, 800%, or that is selected from a range that is greater than or equal to 400% and less than or equal to 1,200%. In an aspect, including for interfacing with a user's skin, the substrate may be a silicone material, such as Ecoflex® silicone (Shore 00-30 hardness (Smooth-On, Inc.)).

[0077] In one aspect, any of the electronic devices provided herein comprise an array of functional electronic devices. In one embodiment, the functional electronic devices are sensors, actuators, or both sensors and actuators. For example, a sensor may provide information about a physical parameter related to the electronic device, such as sensor motion, velocity, acceleration, or about a physical parameter associated with a surface in which the electronic device physically contacts, e.g., pressure, force, temperature, electric potential, conductivity, hydration, moisture, electromagnetic radiation, or for any parameter that a sensor is capable of measuring. An actuator, in contrast, functions to provide a signal or stimulus to a surface. Optionally, the plurality of actuators may be controlled by a plurality of sensors, such as actuators on an inner surface and sensors on either the outer surface or the outer surface of another substrate. In this manner, virtual reality systems are provided, such as a user that "feels" what another surface "feels" like without actually touching the surface, such as by a remote controlled instrument or robotic device having a surface covered with any of the devices provided herein. Alternatively, a multi-functional device, such as a glove, may have sensors on the outer surface to sense a parameter which is then transmitted to a stimulator on the inner surface in conformal contact with the user skin. In this manner, information about a condition outside the glove is detected by a user via the stimulator on the inner surface.

[0078] One manner in which the ability to flip and/or stretch substrate surfaces to accommodate shaped surfaces, even highly irregular shapes, without sacrificing device functionality is by specially constructing and packaging the electronic layout and geometry so that rigid materials most susceptible to fracture are insulated from high stresses. For example, flexible and stretchable interconnects may be incorporated into the functional electronic devices and positioned so as to accommodate bending and flexing stresses, thereby insulating rigid or brittle materials from unduly high stresses. The interconnects electrically connect a functional electronic device, including multiple functional electronic devices, that may be configured as rigid device islands. In an embodiment, the flexible and stretchable electrical interconnect comprises an electrically conductive metal in a bent configuration. Examples of bent configurations include

wavy geometry (see, e.g., U.S. Pat. No. 7,622,367 (38-04A)), buckle geometry (see, e.g., U.S. Pat. No. 8,217,381 (134-06)), and/or serpentine configurations (see, e.g., U.S. Pat. Pub. 2010/0002402 (213-07); PCT Pub. WO2011/084450 (126-09WO); U.S. Pat. Pub. 2013/0041235 (29-11)).

[0079] Optionally, an interconnect comprises a nanowire in a serpentine configuration. High flexibility and bendability is achieved particularly by providing interconnect cross-sectional dimensions that are small relative to the more rigid components that the interconnects connect. For example, the nanowire can have a rectangular cross-section, with a thickness selected from a range that is greater than or equal to 50 nm and less than or equal to 1 μm , and a width that is selected from a range that is greater than or equal to 1 μm and less than or equal to 1 mm. In an aspect, the serpentine configuration is characterized by an average radius of curvature, such as selected from a range that is greater than or equal to 100 μm and less than or equal to 10 mm.

[0080] In an aspect, the electronic device comprises a plurality of interconnects arranged in at least two interconnect layers, with adjacent interconnect layers separated by a barrier layer that is an electrically insulative elastomeric layer, thereby providing compact wiring with overlying interconnects.

[0081] The electrical interconnects are particularly advantageous in embodiments wherein the functional electronic devices are relatively rigid, such as being made from relatively brittle components, including semiconductor components such as thin layers. In an aspect, the functional electronic devices comprise rigid device islands that are electrically connected to at least one interconnect. In this aspect, the interconnect bent configuration accommodates stresses from bending and stretching of the thin elastomeric substrate, thereby isolating the rigid device islands from applied stresses. In an aspect, the bending and stretching stresses are from flipping the inner and outer surfaces of the thin elastomeric substrate.

[0082] Any of the electronic devices provided herein may comprise an array of functional electronic devices characterized by a total number of functional electronic devices, such as a number selected from a range that is greater than or equal to 2 and less than or equal to 1000. In an aspect, the number is from between about 4 and 100. In an aspect, the number is from between about 4 and 20. In an aspect, any of the arrays described herein are further defined in terms of a footprint area, wherein the footprint area is the surface area covered by the array, and can be defined as the outer-most portion of individual devices within the array. Accordingly, based on the number of functional electronic devices and the footprint area, a spatial density is determined. For applications requiring fine spatial resolution, there may be as many as about 1 to 10 devices per mm^2 . For other applications where fine spatial resolution is not necessary, the devices may be more sparsely distributed, such as 1 to 10 devices per cm^2 .

[0083] In an aspect, the functional electronic device comprises a multiplexed array of electrotactile stimulators for interfacing with a curved surface, wherein the curved surface corresponds to living tissue.

[0084] In an embodiment, any of the electronic devices provided herein are part of a human-machine interface, such as an instrumented glove or a medical glove for surgery. The electronic devices are readily used in other applications,

including an array of force or pressure sensors for measuring force or pressure exerted against a surface. Such an application can provide a highly accurate understanding of, for example, forces exerted against a surface and correspondingly provide warnings or alarms if threshold values are exceeded. This can occur, for example, on any biological surface.

[0085] In an aspect, the inorganic semiconductor components and/or the metallic conductor components independently comprise one or more thin film structures having a thickness that is less than or equal to 1 μm .

[0086] In an embodiment, the electronic device comprises one or more inorganic semiconductor components, such as inorganic semiconductor components independently comprising a nanomembrane structure, a polycrystalline semiconductor material, single crystalline semiconductor material or a doped polycrystalline or single crystalline semiconductor material.

[0087] In an aspect, the device has a neutral mechanical plane (NMP), wherein the NMP is positioned at a depth that corresponds to the inorganic semiconductor position within the device, such as an inorganic semiconductor that is a nanomembrane. Such NMP positioning further assists in device tolerance to bending and stretching stresses, such as occurs during flipping of the substrate inner and outer surfaces.

[0088] In an aspect, the device comprises one or more metallic conductor components, such as a metallic conductor component that is an electrical interconnect having a curved geometry. The curved geometry may be at least partially free-standing. The curved geometry may comprise a serpentine configuration, with the bending either in plane, out of plane, or a combination thereof. In an embodiment, electrical interconnects electrically connect rigid device islands. In an aspect, rigid device islands comprise an inorganic semiconductor, such as a silicon nanomembrane.

[0089] In an aspect, the rigid device islands correspond to positions of sensors or actuator components that tend to be strain-sensitive due to various parts that are relatively brittle and susceptible to physical fracture. In an aspect, the sensors or actuators are electrotactile devices, motion sensors, pressure sensors, pressure actuators, thermal sensors, thermal sources, or a combination thereof the configuration may be described as a mesh geometry, in that the curved interconnects are configured to accommodate stresses not otherwise well-tolerated by a rigid device island.

[0090] As described, the functional electronic device can be supported by the substrate outer surface or by the substrate inner surface, particularly in view of the embodiment where the substrate is flippable. In an aspect, the outer surface that supports the functional electronic device is flipped, so that after flipping the functional electronic device supported by the outer surface is the functional electronic device supported by the inner surface. In an aspect, after flipping at least 90% of the functional electronic devices on the inner surface remain functional after flipping from an outer surface facing to an inner facing surface geometry. In this manner, the enclosure defined by the inner surface actually corresponds to a substrate surface that was originally an outer surface.

[0091] In an embodiment, for example, at least a portion of the one or more inorganic semiconductor components, one or more metallic components or both are printable structures. In an embodiment, for example, at least a portion

of the one or more sensors, actuators or both are assembled on said flexible or stretchable substrate via transfer printing. In an embodiment, for example, at least a portion of said one or more sensors, actuators or both are assembled on said flexible or stretchable substrate via microtransfer printing, dry contact transfer printing, solution-based printing, soft lithography printing, replica molding, or imprint lithography.

[0092] In an embodiment, the thin elastomeric substrate inner surface defines an enclosure or an interior volume having at least one opening for receiving and covering a curved surface. In an aspect, the surface to be covered and contained within the enclosure is an object that is part of a living animal, such as an appendage, a finger, an arm portion, a leg portion, a head portion or a torso portion.

[0093] In an embodiment, the thin elastomeric substrate inner surface that defines the enclosure for receiving a curved surface and the substrate has physical properties to receive, accommodate and conformally contact under a self-generated contact force, the curved surface. In an aspect, the physical properties correspond to a substrate Young's modulus that is less than or equal to 500 kPa, and a substrate fracture strain that is greater than or equal to 500%. Functionally, this ensures the substrate can conformally contact even highly irregularly shaped surfaces and also can undergo surface flipping without adverse impact to structural integrity.

[0094] In an aspect the enclosure has a receiving dimension that is smaller than a corresponding dimension of the curved surface, wherein during use a strain in the thin elastomeric substrate increases the receiving dimension to accommodate the received surface within the enclosure without adversely impacting the functional electronic device. For example, if the substrate is for receiving a finger, the enclosure may have a diameter that is less than the diameter of the finger. Accordingly, during use the finger stretches the elastomeric substrate, thereby generating a radially-directed contact force between the finger surface and the substrate. In this manner, the strain generates an intimate contact force between the thin elastomeric substrate and the curved surface within the enclosure to establish and maintain intimate and conformal contact between the device component on the substrate inner surface and the curved surface.

[0095] The amount of strain in the substrate may be varied so as to control the amount of contact force between the substrate, and therefore any functional devices on the inner substrate surface, and the surface within the enclosure. For applications where greater contact force is required, a characteristic dimension of the enclosure is corresponding decreased relative to the size of the object being accommodated. For example, the enclosure volume reduced by decreasing a diameter of the enclosure. In an aspect, the electronic device during use has a strain that is selected from a range that is greater than or equal to 1% and less than or equal to 100%. Of course, due to the large fracture strain of the elastomeric substrate as well as the highly flexible and elastic electronic devices, such as by the use of flexible and stretchable interconnects and thin layout geometry, the invention can accommodate even higher strains and stresses as desired.

[0096] The electronic device may be further described in terms of the enclosure (also referred herein as, and used interchangeably with, interior portion or interior volume),

including interior portion length, width, depth and/or volume. For example, the enclosure may be cylindrically shaped with an average diameter of 5 mm to 30 cm, and/or an average length of 5 mm to 30 cm. In an aspect, the enclosure has a volume that is greater than or equal to 1 cm^3 and less than or equal to $10,000 \text{ cm}^3$.

[0097] In an aspect, the electronic device is an array of electronic devices with an electronic device spatial density selected from a range that is between about 1 mm^{-2} (high density coverage) and 1 cm^{-2} (low density coverage).

[0098] In an embodiment, the enclosure has a substantially cylindrical or partially spherical or hemispherical shape. The cylindrical shape is optionally covered at one end, such as to cover a finger-tip. Accordingly, any of the electronic devices may have an interior portion shaped to receive a finger or a finger-tip. The cylindrical shape may also be a tube that is open at both ends.

[0099] In an aspect, the enclosure is a partially-closed volume, so that the curved surface is covered such as by forcing the curved surface into the interior portion. In contrast, an open volume refers to an enclosure having at least one end free to move in that is not contiguously connected with another portion of the substrate. In this manner, an open volume may correspond to wrapping the inner surface around a curved surface and securing a loose end of the substrate to form the interior portion. This can be achieved by wrapping the thin elastomeric substrate around the curved surface under a longitudinally-directed tension ensures surface cover and conformal contact, under a substrate self-generated force. Alternatively, the thin elastomeric substrate can be rolled over the biological surface under a circumferentially-directed tension, such as by forcing an opening of the partially-closed volume to open further to receive the biological surface.

[0100] In an embodiment, any of the electronic devices described herein may be multifunctional. Multifunctional refers to there being at least two different types of functional electronic devices that provide different functions, such as an electrotactile stimulator and a sensor device. In an aspect, the inner surface supports a first array of functional electronic devices, and the outer surface supports a second array of functional electronic devices, with the first array having a different functionality than the second array. For example, the first array may comprise electrotactile stimulators for interfacing with skin of a living animal in conformal contact with the electronic devices of the first array, and the second array may comprise sensors for measuring a physical parameter from tactile interaction between the electronic devices of the second array and an external surface. Examples of sensors include strain gauge sensors and tactile sensors, such as piezoresistive, piezoelectric, capacitive and elastoresistive sensors.

[0101] In an aspect, the first array of electrotactile stimulators interface with skin of a living animal in accordance with a physical parameter measured by the second array of sensors, such as sensors and stimulators on the outside and inside of a substrate covering a finger.

[0102] In an embodiment, the array of functional electronic devices have a footprint surface area defined by the outermost members of the array. The methods of making the devices are compatible with a wide range of footprint surface areas, depending on the application of interest. In

one example, the footprint surface area is selected from a range that is greater than or equal 0.5 cm^2 and less than or equal to 100 cm^2 .

[0103] In an embodiment, the array of functional electronic devices comprise a multiplexed array of electrotactile stimulators for interfacing with living tissue. In an aspect, the array of functional electronic devices comprises an array of electrodes, such as electrodes for sensing an electrical parameter and/or for application of an electrical parameter, such as electric potential. In an embodiment, each electrode comprises an inner disk having a diameter that is less than 1 mm and an outer ring that surrounds the inner disk, wherein the inner disk and outer ring are concentrically positioned relative to each other, with a separation distance between the inner disk and outer ring selected from a range that is greater than or equal to $100 \mu\text{m}$ and less than or equal to $500 \mu\text{m}$. In an aspect, the thickness of the electrodes is less than $1 \mu\text{m}$, such as on the order of hundreds of nanometers (e.g., 100 nm to 900 nm). In an aspect, any of the semiconductor components comprise a silicon nanomembrane that is part of an electronic device that is a diode, such as diode having a thickness that is less than $1 \mu\text{m}$, or on the order of hundreds of nanometers (e.g., 100 nm to 900 nm). The diodes and electrodes may comprise part of a multiplexed circuit to facilitate device control and output processing, especially for arrays comprising a large number of functional electronic devices.

[0104] In another embodiment, the invention is a method for making any of the devices described herein. In an aspect, provided is a method of making an electronic device to cover and interface with a curved surface by providing an elastomeric substrate having an inner facing surface and an outer facing surface. A functional electronic device, such as an array of functional electronic devices, is transfer printed to the elastomeric substrate outer facing surface. The elastomeric substrate is flipped, so that after flipping the outer facing surface is the inner facing surface and the inner facing surface is the outer facing surface, thereby providing the array of device components on the inner facing surface, wherein after flipping the array of functional electronic devices remain functional. Remain functional refers to at least 90%, at least 95%, or all functional electronic devices remaining functional after flipping. The desired functionality level is achieved by incorporating any one or more of the device geometries provided herein, including by using ultra-thin devices and device components (e.g., less than $1 \mu\text{m}$), flexible and stretchable interconnects, including serpentine geometries, and neutral mechanical plan (NMP) layouts. Accordingly, any one or more of these device layouts and geometries may be incorporated in any one or more of the methods disclosed herein to achieve robust devices even after stresses associated with surface flipping.

[0105] In an aspect, the inner facing surface defines an interior volume or portion for receiving, covering and interfacing with the curved surface. In an aspect, the enclosure of the elastomeric substrate is obtained by casting an elastomeric precursor against a curved surface or a mold thereof and curing the elastomeric precursor to obtain the elastomeric substrate having an inner facing surface and an outer facing surface. In this fashion, the substrate may be tailored to specific curved surfaces that will be used in the system. In particular, an elastomeric substrate having a surface curvature at rest that corresponds to the curved surface may be generated. Optionally, the resultant cured substrate has a

slightly smaller interior volume dimension than the corresponding dimension of the object that has the to-be-received curved surface. For example, the mold of the surface may be correspondingly slightly reduced in size. This is one means for ensuring there is a self-generated contact force generated by strain of the elastomeric substrate to accommodate the to-be-received curved surface. In an aspect, the mold size is selected so as to generate a strain in the elastomeric substrate that is selected from a range that is greater than or equal to 1% and less than or equal to 100%, or between about 1% and 20%. Alternatively, the substrate curvature at rest may be made by another process known in the art, such as extrusion.

[0106] In an aspect, the transfer printing comprises transferring the array functional electronic devices from a transfer stamp to an outer surface of the elastic substrate, such as by transfer printing (see, e.g., U.S. Pat. No. 7,943,491 (41-06); U.S. Pat. No. 7,799,699 (43-06); U.S. Pat. No. 7,932,123 (151-06); U.S. Pat. No. 8,217,381 (134-06); U.S. Pat. No. 8,198,621 (38-04D), U.S. Pat. No. 7,622,367 (38-04A), all of which are specifically incorporated by reference). In an embodiment, particularly for elastomeric substrates having a curved surface, the transfer printing further comprises flattening the elastomeric substrate into a flat geometry and transferring the array of functional electronic device to the elastic substrate in the flat geometry. After transfer, the elastomeric substrate may be released to relax back into its curved surface geometry. In another aspect, the transfer printing comprises rolling the transfer stamp over the outer surface of said elastic substrate in a curved geometry.

[0107] In an aspect, the curved surface to-be-received in the interior volume or portion has a surface shape that corresponds to a finger or a finger-tip surface shape.

[0108] In an aspect, the electronic device is incorporated into a finger or fingertip of a glove. In an aspect, the functional electronic device comprises an array of sensors, actuators, or sensors and actuators.

[0109] In an embodiment, the functional electronic device comprises an array of electrotactile electrodes in a mesh configuration, wherein electrical interconnects are electrically connected to the electrotactile electrodes.

[0110] In an aspect, the invention is a method of using any of the devices herein, such as a method of interfacing with a surface of an object. In an embodiment, the method comprises providing a thin elastomeric substrate having an inner facing surface defining an enclosure, and an outer facing surface. A functional electronic device is supported on the inner facing surface or the outer facing surface. The functional electronic device comprises a device component that is one or more inorganic semiconductor components, one or more metallic components, or one or more inorganic semiconductor components and one or more metallic components. The functional electronic device is stretchable and bendable with a thickness that is less than or equal to $10 \mu\text{m}$. The surface that supports the functional electronic device is physically contacted with an object surface to interface the functional electronic device with the object surface of an object. In an aspect, the enclosure receives an object and attendant surface so as to provide physical support to the substrate. In an aspect, the method relates to expanding the volume of the enclosure so as to accommodate the object and curved surface being received within the enclosure.

[0111] For devices on the inner substrate surface, the method further comprises introducing the surface of an

object to the enclosure for interfacing. For example, the object may be part of a living animal and the object surface corresponds to skin or epidermal layer. The functional electronic device may comprise an array of sensors, actuators, or both sensors and actuators. In an embodiment, the device comprises an array of electrotactile stimulators, such as for stimulating nerves in the skin or epidermal layer underlying the electrotactile stimulators.

[0112] Alternatively, for functional electronic devices supported by an outer facing surface, the physically contacting step may comprise introducing the surface of an object that is external to the substrate enclosure to the outer facing surface. In this aspect, the functional electronic devices on the outer surface interface with the externally located object surface, including sensors that measure a tactile sensation. In an aspect, the method further comprises the step of inserting a supporting object into the interior portion to physically support the elastomeric substrate. For example, in remote sensing the supporting object may be part of a remotely controlled object or a robotically controlled device. In this aspect, the functional electronic device may comprise an array of sensors for measuring a physical parameter of the object surface, ranging from a tactile-generated force parameter, to an inherent surface-related parameter such as temperature, conductivity, hardness, resilience or another parameter depending on the application of interest.

[0113] In another embodiment, a first functional electronic device is supported by the inner facing surface and a second functional electronic device is supported by the outer facing surface, and the physically contacting step comprises introducing a surface of a first object to the interior portion and a surface of a second object to the outer surface. For example, the first object may correspond to an appendage of a living person, and the first functional electronic device is part of an array of electrotactile stimulators that interfaces with a tissue overlying the appendage. The appendage may be a finger or fingertip where an electrotactile stimulation is provided that depends on the interaction of the of the second functional electronic device supported on the outer surface with the second object surface. In the case of a surgical glove, the second object surface may be part of a patient, such as biological tissue.

[0114] Any of the devices and processes provided herein may relate to an enclosure that receives a portion of the human body, including a finger, a fingertip or any other parts disclosed herein.

[0115] Provided herein are electronic devices configured to conform to a biological surface of user, including an epidermal layer or a skin layer. In an embodiment, the biological surface corresponds to an appendage. In an embodiment, the biological surface is a finger or multiple fingers, including the finger-tip. In an embodiment, the biological surface is a part of the human body, including the epidermis or skin. The device is particularly useful for mounting to a shaped portion of a user surface, including a user surface that moves and/or deforms. One aspect of the invention is that the electronic device is provided on a flexible, deformable and/or bendable substrate that, when appropriately mounted on the user, provides a self-generated force to ensure the electronic device is in good contact with the user surface, with the contact well-maintained and durable even over long periods of time, ranging from many minutes to many hours or days, as desired depending on the application of interest.

[0116] In an embodiment, the electronic device has a substrate with a three-dimensional curvature matched to a biological surface curvature. "Three-dimensional curvature" refers to a surface that is defined by (x, y, z) co-ordinates, or transformations thereof. The curvature is considered "matched" to a biological surface when there is substantial correspondence between the substrate surface and biological surface, particularly for that portion of the substrate receiving surface that supports the array of components. In this embodiment, the receiving surface of the substrate, and the array of components, is capable of physical contact, including conformal contact, with the biological surface. The substrate receiving surface, when oriented in an inner-facing direction, defines an enclosure having an inner volume that is configured to receive the biological surface, such as a finger, appendage, or other accessible portion of the user.

[0117] A functional benefit of the device configuration that provides an enclosure and inner volume for receiving a user body part is that the device substrate can provide a self-generated force to ensure intimate contact between the biological surface and the components of the array. In an aspect, the self-generated force is sufficient that no adhesive components or external force generation is required, and absence of those components does not impact the ability to reliably generate and maintain conformal contact.

[0118] The self-generated force from the device substrate may be a physical force applied in a normal direction with respect to an individual component within the array of components. Although force is applied in multiple directions, with a direction and magnitude that may vary over the biological surface, for an individual component a normal force on that component can be calculated from this force distribution. This normal force can be generated by various embodiments. In one embodiment, the electronic device is wrapped over a biological surface under tension, thereby providing the desired force. Alternatively, the electronic device can be rolled over a surface, with an effective circumferentially-directed tension providing the normal force to ensure conformal contact between the device and the underlying biological surface, even over a range of curved surfaces spatially varying over each of the three spatial dimensions.

[0119] The configuration of the device ensures that even when the device experiences substantial stresses, such as during application of the device to the skin, finger, or other region of the body, a majority of the components in the array remain functional. In an aspect, at least 70%, at least 90%, at least 95%, or about all of the components or functional electronic devices remain functional after application to the biological surface, including by manipulation of the surface orientation to ensure the array of components are inner-facing and positioned for physical and/or conformal contact with the skin.

[0120] In an aspect, the device inner volume is formed by flipping the array of components supported by the receiving surface from an outer-facing to an inner-facing configuration. This aspect is particularly relevant for those devices where the array of components is transfer printed to a physically-accessible surface, e.g., the outer-facing surface. Such an outer-facing surface is properly configured to provide conformal contact by flipping the substrate so that the previously positioned outer-surface corresponds to the inner-facing surface.

[0121] In an embodiment, the substrate forms an open-tube volume, where the substrate has two open ends, and between the open ends there is conformal contact with a biological surface. Such a configuration is relevant for devices that are slipped over an appendage with a portion of the appendage extremity not covered, such as a finger sleeve (e.g., fingertip less gloves), arm-band, leg-band or forehead-band, or wraps thereof. In this aspect, the inner volume does not have physical end surfaces, but instead ends defined by the edges of the substrate. Alternatively, the substrate forms a partially closed volume, such as for a finger confined by the fingertip portion of a glove. In this aspect, one end of the inner volume has a corresponding physical surface, with the other end open to receive the biological surface. In either embodiment, the inner volume may be defined by a depth and a diameter, or characteristic measures thereof, including for example by averaging over the entire substrate for those substrate shapes that are complicated (e.g., non-cylindrical).

[0122] The device is compatible, depending on the desired application, with any number or types of sensors, effectors, actuators or circuit elements, including as disclosed in any of 126-09, 29-11P, 134-06, 3-11, 7-11, 150-11, 38-04C, 38-04D and any other as provided hereinbelow, which are hereby explicitly incorporated by reference for the materials, components, configurations and methods of making and using, as disclosed therein.

[0123] In an aspect, the device is further characterized by any one or more relevant parameters, including dimensions, array characteristics including component number and density, and footprint surface area. Footprint surface area refers to the coverage area of the array, and corresponding area of the biological surface in conformal contact with the array of components. The device is well-suited for configuration over any size area, ranging from relatively small (e.g., 0.5 cm²) to relatively large (e.g., 100 cm² or greater).

[0124] Also provided herein are related methods for making or for using any of the devices disclosed herein. Various physical characteristics of the devices provide the ability to specially manipulate the device to achieve functional benefit. For example, the substrate is capable of being shaped to any desired surface and an electronically active material transferred thereto. For transfer printing, the outer surface of the substrate is configured as a receiving surface of the electronically active material as the outer-facing surface is generally more accessible than an inner-facing surface. The deformability of the substrate provides the ability to then flip the receiving surface from an outer-facing configuration to an inner-facing configuration, thereby facilitating intimate contact between the electronically active material with a biological surface when the device is mounted or applied to the biological surface.

[0125] In an aspect, the invention provides a method of making appendage mountable electronic system, the method comprising the steps of: (i) providing a flexible or stretchable substrate having an initially inner facing surface defining an original enclosure; and an initially outer facing surface; (ii) transfer printing a flexible or stretchable electronic device comprising one or more sensors, actuators or both to the initially outer facing surface of the flexible or stretchable substrate; the sensors, actuators or both comprising one or more inorganic semiconductor components, one or more metallic components, or one or more inorganic semiconductor components and one or more metallic components; wherein at least a portion of the inorganic semi-

conductor components, metallic components or both has a thickness less than or equal to 500 microns; and (iii) flipping the elastomeric substrate so that after flipping the initially outer facing surface becomes a subsequently inner facing surface defining a final enclosure for receiving an appendage and the original inner facing surface becomes a subsequently outer facing surface, thereby providing the electronic device on the subsequently inner facing surface; wherein after the step of flipping the substrate the flexible or stretchable device remains functional.

[0126] In an embodiment, for example, the appendage is a hand, a finger, a finger-tip, a skull, a foot, a toe, a let, a torso, or any portion thereof. In an embodiment, for example, the step of providing the flexible or stretchable substrate comprises: (i) casting an elastomeric precursor against a surface of the appendage or a mold thereof; and (ii) curing the elastomeric precursor to obtain the flexible or stretchable substrate having an enclosure shape at rest that corresponds to a shape of the appendage. In an embodiment, for example, the step of transfer printing comprises transferring an array of actuators, sensors, or actuators and sensors, via a technique selected from the group consisting of microtransfer printing, dry contact transfer printing, solution-based printing, soft lithography printing, replica molding, and imprint lithography. In an embodiment, for example, the step of transfer printing comprises transferring the array of actuators, sensors, or actuators and sensors from an elastomeric transfer stamp to the initially outer surface of the elastic substrate. In an embodiment, for example, the step of the transfer printing further comprises flattening the elastomeric substrate into a flat geometry and transferring the array of actuators, sensors, or actuators and sensors to the elastic substrate in the flat geometry. In an embodiment, for example, the step of the transfer printing further comprises rolling the elastomeric transfer stamp over the outer surface of the elastic substrate in a curved geometry. In an embodiment, for example, the final enclosure has an inner surface shape that corresponds to a finger or a finger-tip surface shape. In an embodiment, for example, the system is incorporated into a finger or fingertip of a glove.

[0127] In an embodiment, for example, the step of transfer printing one or more sensors, actuators or both to the subsequently outer surface of the flexible or stretchable substrate, thereby providing a first sensor, or actuator or both on the subsequently inner surface and a second sensor, or actuator or both on the subsequently outer surface. In an embodiment, for example, the first sensor, or actuator or both comprises an array of electrotactile stimulators, and the sensor, or actuator or both comprises an array of tactile sensors. In an embodiment, for example, the method further comprises the step of communicably connecting the tactile sensors with the electrotactile sensors so that the electrotactile sensors are controlled by an output from the tactile sensors. In an embodiment, for example, the array of electrotactile sensors generate a spatially-varying pattern of electrical stimulation.

[0128] In an aspect, the substrate curvature is obtained by casting a polymer against a desired shape. The desired shape can be the biological surface itself, such as for a custom-fit application. Alternatively, the desired shape can itself be a mold of a biological surface shape. Alternatively, substrate curvature is achieved by a non-casting process, including by use of a commercially available substrate (e.g., a surgical glove).

[0129] An example of a method of making an appendage mountable electronic system by such a casting process is by: (i) providing an appendage or mold thereof; (ii) providing a flexible or stretchable electronic device comprising one or more sensors, actuators or both to a surface of the appendage or mold thereof; said sensors, actuators or both comprising one or more inorganic semiconductor components, one or more metallic components, or one or more inorganic semiconductor components and one or more metallic components; wherein at least a portion of said inorganic semiconductor components, metallic components or both has a thickness less than or equal to 500 microns; (iii) introducing a prepolymer to the flexible or stretchable electronic device supported by the surface of the appendage or mold thereof; and (iv) polymerizing the prepolymer to form a flexible or stretchable substrate having an inner surface that supports the flexible or stretchable electronic device. Optionally, the method further comprises the step of removing the substrate and flexible or stretchable electronic device from the surface of the appendage or mold thereof.

[0130] Any of the methods may further comprise the step of transfer printing a flexible or stretchable electronic device comprising one or more sensors, actuators or both to an outer surface of the flexible or stretchable substrate; said sensors, actuators or both comprising one or more inorganic semiconductor components, one or more metallic components, or one or more inorganic semiconductor components and one or more metallic components; wherein at least a portion of said inorganic semiconductor components, metallic components or both has a thickness less than or equal to 500 microns. In this manner, electronic devices are provided to both internal and external surfaces without having to flip the substrate surfaces.

[0131] In an embodiment, the transfer printing comprises transferring the electronically active material to the substrate that has been flattened. Alternatively, such as for a substrate that remains positioned against the user surface or mold thereof, the transfer printing can be to the curved surface, such as by a rotational or rolling motion of the stamp over the curved surface.

[0132] Without wishing to be bound by any particular theory, there may be discussion herein of beliefs or understandings of underlying principles relating to the devices and methods disclosed herein. It is recognized that regardless of the ultimate correctness of any mechanistic explanation or hypothesis, an embodiment of the invention can nonetheless be operative and useful.

BRIEF DESCRIPTION OF THE DRAWINGS

[0133] FIG. 1. Schematic illustration of the process for transfer printing an interconnected device structure from a substrate on which it is fabricated to an elastomeric sheet. (a) Interconnected sensors and electronics formed on a silicon wafer in an open mesh geometry are lifted onto the surface of a PDMS slab (i.e. stamp); (b) the backside of the mesh and the supporting PDMS stamp are coated with a thin layer of SiO₂ and then pressed onto an elastomeric sheet (Ecoflex); (c) removing the PDMS completes the transfer.

[0134] FIG. 2. Process for fabricating a multiplexed array of electroactile stimulators in a stretchable, mesh geometry on the inner surface of an elastomeric finger-tube. (a) casting and curing an elastomer precursor on the finger of a model hand yields a thin (~500 μm thick), closed-form membrane, i.e. a finger-tube; (b) a PDMS stamp (here, backed by a glass

microscope slide) delivers the electroactile device to the outer surface of this finger-tube, while compressed into a flattened geometry; (c) electroactile array on the outside of the freestanding finger-tube; (d) turning or flipping the tube inside out relocates the array on the inner surface of the finger-tube, shown here at the midway point of this flipping process, so that the previous outer surface is the inner surface and the previous inner surface is the outer surface.

[0135] FIG. 3. Mechanics modeling of the “flipping-over” process and application to arrays of electroactile stimulators multiplexed with Si NM diodes. (a) Calculated (analytical and FEM) profiles of an Ecoflex finger-tube during bending associated with flipping the tube inside out, showing a linear relationship between the radius ($R_{radial}=7.5$ mm) of the tube and the minimum bending radius (R_{axial}); (b) FEM results for maximum strains on the inner and outer surfaces during this process; (c) schematic illustration of a multiplexed electroactile array with serpentine mesh interconnects, with magnified diagram (right top) and image (right bottom) of a PIN Si NM diode (after flipping-over); (d) schematic cross sectional illustrations of two regions of the device, with the position of the NMP indicated with a dashed red line, and analytical results for the maximum strains during the flipping-over process; (e) I-V characteristics of a Si NM diode before and after flipping-over; (f) maximum strain in the Si NM diode and h_{NMP} (the offset between the neutral mechanical plane and the lower surface of the Si NM) as a function of the thickness of the Si NM.

[0136] FIG. 4. Mechanics and electrical characteristics of a 2x3, multiplexed electroactile array on a fingertube. (a) Voltage required for electroactile sensation as a function of stimulation frequency. Inset: electroactile array on human finger during experiments; (b) I-V characteristics of multiplexed electroactile electrodes in contact with a human thumb; (c) circuit diagram of the diode multiplexing scheme; (d) function table showing inputs for addressing each of the six channels (H=High; L=Low).

[0137] FIG. 5. Detection of finger motion with arrays of stretchable Si NM strain gauges. (a) FEM results of the maximum principle strain for a 1x4 array of gauges (straight, vertical structures near the top of the serpentine interconnect mesh) due to an overall 10% strain applied along the longitudinal (y) direction. The upper inset shows the strains in the gauge highlighted by the yellow dashed box. The lower inset provides an image of a fabricated device with a layout that matches that of the FEM results; (b) experimentally measured and analytically calculated changes in resistance for a representative Si NM strain gauge as a function of applied strain along the longitudinal direction. The inset provides an SEM image of a portion of the device, with the Si NM gauge located in the dashed box; (c) images of a strain gauge array on a finger-tube mounted on the thumb, in straight (I) and bent (II) positions; (d) change in resistance of a representative gauge during three bending cycles (black) and side-to-side motion (red); (e) images of a strain gauge array on a thin, elastomeric sheet laminated onto the metacarpal region of the thumb in straight (III) and sideways deflected (IV) positions; (f) change in resistance of gauges at two ends of the array during three cycles of side-to-side motion.

[0138] FIG. 6. Tactile sensing with integrated capacitance sensors. (a) sensors on the anterior of the thumb; (b) inner electrodes for a 2x3 array of sensors (electroactile electrodes); (c) outer electrodes for the same array; (d) measured

and analytically calculated change in capacitance of a single sensor with applied pressure and tensile strain.

[0139] FIG. 7. Schematic of the basic fabrication process. (a) Si substrate; (b) spin coat sacrificial PMMA; (c) spin coat polyimide (PI) precursor/250° C. bake in inert atmosphere; (d) Au evaporation/patterning; (e) spin coat PI precursor/250° C. bake in inert atmosphere; (f) O₂ RIE to expose Au electrodes and form PI mesh structure; (g) PMMA undercut in acetone/application of PDMS stamp; (h) devices transferred to PDMS stamp; (i) Cr/SiO₂ evaporated onto back of device; (j) PDMS stamp pressed onto UV exposed Ecoflex; (k) transfer completed with PDMS stamp removal.

[0140] FIG. 8. Schematic illustration of the flipped-over elastomeric Ecoflex tube in the plastic hand model.

[0141] FIG. 9. Schematic illustration of an array of functional electronic devices on an inner surface of an elastomeric substrate.

[0142] FIG. 10. Schematic of silicon transfer printing. (a) silicon on insulator (SOI) substrate; (b) RIE etch release holes (3 μm) in Si layer; (c) wet etch (buffered oxide etch) of SiO₂ layer to release Si layer; (d) PDMS stamp pressed into contact with Si; (e) Si transfer to PDMS stamp upon removal; (f) PDMS stamp with transferred Si pressed onto PI layer; (g) After heating at 150° C. for 4 min, Si transferred to device upon stamp removal.

[0143] FIG. 11. Schematic of the fabrication process for electroactile stimulators. (a) silicon substrate; (b) spin coat 100 nm sacrificial PMMA; (c) spin coat/250° C. bake 1.2 μm polyimide; (d) transfer of Si layer with PIN diodes (release holes not shown); (e) RIE isolation of Si nanomembrane PIN diodes and Au evaporation/patterning; (f) spin coat/250° C. bake 1.2 μm polyimide; (g) contact vias for diodes formed in PI with O₂ RIE; (h) Au evaporation/patterning; (i) spin coat/250° C. bake 1.2 μm polyimide; (j) O₂ RIE to form polyimide mesh structure and expose electroactile electrodes.

[0144] FIG. 12. Schematic of the fabrication process for strain gauges. (a) silicon substrate; (b) spin coat 100 nm sacrificial PMMA; (c) spin coat/250° C. bake 1.2 μm polyimide; (d) transfer of p-doped Si (release holes not shown); (e) RIE isolation of Si strain gauge nanomembranes; (f) Au evaporation/patterning; (g) spin coat/250° C. bake 1.2 μm polyimide; (h) O₂ RIE to form polyimide mesh structure.

[0145] FIG. 13. Schematic of the fabrication process for tactile electrodes. (a) silicon substrate; (b) spin coat 100 nm sacrificial PMMA; (c) spin coat/250° C. bake 1.2 μm polyimide; (d) Au evaporation/patterning; (e) spin coat/250° C. bake 1.2 μm polyimide; (f) O₂ RIE to form polyimide mesh structure.

[0146] FIG. 14(A-C) provides different views of an appendage mountable electronic system of the invention.

[0147] FIG. 15 provides view of an appendage mountable electronic system of the invention accommodating an appendage and interacting with an external surface.

[0148] FIG. 16 shows a system having electronic devices supported on the inner surface 30 of the substrate.

[0149] FIG. 17 shows a method for making an appendage mountable electronic system of the invention.

[0150] FIG. 18 is a process flow summary of one embodiment for making any of the systems disclosed herein.

[0151] FIG. 19 is a schematic of a capacitance-based tactile sensor on both inner and outer substrate surfaces.

[0152] FIG. 20 is a process flow summary of one embodiment for making any of the systems disclosed herein by casting a substrate against an object surface.

DETAILED DESCRIPTION OF THE INVENTION

[0153] In general, the terms and phrases used herein have their art-recognized meaning, which can be found by reference to standard texts, journal references and contexts known to those skilled in the art. The following definitions are provided to clarify their specific use in the context of the invention.

[0154] “Enclosure”, “interior volume”, or “interior portion” are used interchangeably and refers to the space bounded by the inner surface of the elastomeric substrate. Accordingly, in aspects where the inner surface defines a small enclosure, or having an access opening that is small, the enclosure interior volume is correspondingly confined and not readily accessible from the outside. This confinement may make it not practical to reliably place and position functional electronic devices on the inner surface defining the enclosure. The invention is compatible with a wide range of substrates. For example, the substrate may be described in terms of various physical properties, such as a modulus or a thickness. In an embodiment, the modulus is a Young’s modulus that is less than about 50 MPa, such as between about 100 kPa and 50 MPa. In an embodiment, the thickness is less than 1 mm, such as between about 0.1 mm and 1 mm.

[0155] As used herein, “conform” refers to a substrate which has a bending stiffness that is sufficiently low to allow the device, material or substrate to adopt any desired contour profile, for example a contour profile allowing for conformal contact with a surface having a three-dimensional curvature, including a curvature that may change over time or during use. The surface curvature may be highly irregular, in that the surface to be covered may have major surfaces that face each other. Accordingly, the conform aspect is not simply an overlay of a substantially two dimensional surface, but rather relates to covering a surface of a three-dimensional object having a defined volume.

[0156] “Appendage” is used broadly herein to refer to any three-dimensional object with a three-dimensional volume defined by one or more curved and/or planar surfaces. In certain embodiments, the appendage corresponds to living tissue. In an aspect, the appendage is a living tissue in a biological environment, such as part of a living animal. In an embodiment, the appendage surface corresponds to bone, skin or an epidermal layer of a living animal, including a human, so that the inner surface of the flexible or stretchable substrate conforms to one or more surface(s) of living tissue. Examples of appendages from a living animal include, but are not limited to, a hand, a finger, a finger-tip, a bone, a skull, a tooth, a head, a foot, a toe, a leg, an arm, a torso, a nose, an ear, genitalia or any portions thereof. In certain embodiments, the appendage corresponds to a non-living object, such as objects of remotely controlled instruments, robotics and the like, including for remote sensing applications. “Conformable” refers to a device, material or substrate which has a bending stiffness that is sufficiently low to allow the device, material and/or substrate to adopt any desired curved surface, for example for conformal contact with a surface having high curvatures. In certain embodiments, the curved surface is an appendage of a user.

[0157] “Conformal contact” refers to contact established between a device and a receiving surface. In one aspect, conformal contact involves a macroscopic adaptation of one or more surfaces (e.g., contact surfaces) of a device to the overall shape of a surface. In another aspect, conformal contact involves a microscopic adaptation of one or more surfaces (e.g., contact surfaces) of a device to a surface resulting in an intimate contact substantially free of voids. In an embodiment, conformal contact involves adaptation of a contact surface(s) of the device to a receiving surface(s) such that intimate contact is achieved, for example, wherein less than 20% of the surface area of a contact surface of the device does not physically contact the receiving surface, or optionally less than 10% of a contact surface of the device does not physically contact the receiving surface, or optionally less than 5% of a contact surface of the device does not physically contact the receiving surface. In an embodiment, a method of the invention comprises establishing conformal contact between an inner surface of the elastomeric substrate that defines an enclosure and an object being inserted into the enclosure. Optionally, the conformal contact further includes one or more single crystalline inorganic semiconductor structures, one or more dielectric structures and/or one or more metallic conductor structures supported by the elastomeric substrate inner surface and a curved surface within the enclosure.

[0158] “Cover”, as used herein refers to the conformal contact region between the elastomeric substrate inner surface and an object surface that is within the enclosure defined by the elastomeric substrate inner surface, specifically under a self-generated contact force that prevents relative movement between the two surfaces. In an aspect, the substrate portions that cover may have a constant and uniform thickness. In an aspect, the cover may have a spatial distribution of substrate thicknesses. Alternatively, cover includes embodiments where the substrate has perforations, such as a mesh or woven configuration, so as to permit surface breathability. The contact force may be uniformly distributed across the cover area or, alternatively, may be spatially distributed such as certain locations where it is critical the surfaces do not move with respect to each other having a higher contact force. That position could correspond, for example, to positions having a high functional electronic device density.

[0159] “Open mesh geometry” refers to a material having at least 20%, at least 40%, at least 60%, or at between about 20% and 80% of the surface area of the material that is open or void space, as defined by an outer perimeter of the material. Accordingly, the material may refer to electrical interconnects that overlay a substrate that may be a continuous surface or may itself be mesh. Interconnects having such an open mesh geometry are optionally tethered to a substrate surface either directly, or indirectly such as at ends connected to rigid device islands that are bonded to the substrate. Such mesh geometry may have a noticeable longitudinally-defined axis, including multiple axis having different alignments to facilitate bending and stretching in more than one direction. In an aspect, the mesh has two directions that are orthogonal or substantially orthogonal with respect to each other. In an aspect, substantially orthogonal refers to within about 10° of absolute perpendicular.

[0160] “Closed tube geometry” refers to a substrate having ends that are constrained and unable to move without substantially affecting other portions of the substrate. One

example of a closed tube geometry is ends of a rectangular substrate that are joined into a cylindrical tube, for example.

[0161] Any of the flexible or stretchable substrates can be further defined in terms of “lateral dimensions”, such as lateral dimensions for receiving an appendage surface. Examples of lateral dimensions include a length, diameter or perimeter along selected cross-sections. The substrate may also be defined in terms of a surface area, such as a surface area available for conformal contact to a surface of the appendage or for contact with an external surface. One advantage of the systems and methods provided herein is that they are compatible with a wide range of dimensions and are selected depending on the application of interest, ranging from 1 mm to 10 cm for small scale, up to and including 10 cm to 1000 cm scale for larger scale applications.

[0162] A central aspect of the various embodiments is an elastomeric substrate that provides a self-generated force to provide and maintain intimate and conformal contact with an object surface in the enclosure. Accordingly, one aspect of any of the devices and methods provided herein is an enclosure having an expandable and adjustable interior volume (in terms of both magnitude and shape) so as to accommodate or receive objects that are bigger than the at-rest enclosure volume or size. For example, a substrate that stretches or is actively stretched to accommodate a curved surface within the enclosure or interior portion, so that the inner surface is in conformal contact with the surface. This can be achieved such as by a substrate interior volume that is sized smaller than the to-be-received surface for an interior volume that is a closed surface. Alternatively, such as for an interior volume that is open, the substrate may be wrapped around the surface under tension, thereby ensuring intimate and conformal contact between an inner surface and the accommodated surface. The ends of the substrate may be fixed in position by an adhesive, a bonding mechanism (e.g., snaps, Velcro, hooks, and the like), or via self-adhesion. This aspect of a self-generated contact force to provide and maintain conformal contact, is particularly useful under strenuous operating conditions that would otherwise adversely affect conformal contact and, therefore, device fidelity. For example, a relatively high contact force may be employed in conditions involving vigorous and substantial movement and forces.

[0163] “Interchangeably flippable” refers to a substrate that can be turned inside-out without permanently impacting a substrate mechanical property or adversely affecting a functionality parameter of the functional electronic device.

[0164] “Functionality parameter” is used to assess whether an electronic device remains functional and/or the degree of functionality or damage. For example, many of the devices and methods provided herein relate to flipping of surfaces to which functional electronic devices are supported. Such flipping is associated with relatively high localized stresses, strains and bending moments. One important functional benefit of the instant invention is the ability to perform such flipping without adversely impacting the associated devices or device components. Conventional electronic devices that are not bendable and flexibly either break outright or have their functionality severely impacted by the act of surface flipping. One manner of quantifying this functional benefit is by comparing device performance before and after the flipping, referred broadly herein as a “functionality parameter”. In an aspect, functionality param-

eter can reflect whether a functional electronic device is operating by assessing the output based on an input that is a physical signal (for a sensor) or an electronic input (for an actuator). This indication is appropriate for assessing degree of non-functionality by deviation for the equivalent input prior to flipping, or total non-functionality. In this case, a user-selected tolerance is selected, such as outputs that within 20%, within 10%, or within 5%, reflected as satisfying functionality. “Without substantial degradation” of a functionality parameter refers to a device satisfying the 20%, 10%, or 5% tolerance when referring to an individual functional electronic device. In an array aspect, it refers to at least 80%, at least 90%, or at least 95% of the array devices remaining functional after flipping.

[0165] “Functional electronic device” refers to an electronic device, such as a sensor or actuator, which interfaces with a surface that is brought into contact with the device. A functional electronic device provides useful information about the interfacing. For example, for tactile sensors the device provides an output that is proportional to a force between the sensor and the surface. For an electrotactile stimulator, there is an electric stimulation or actuation of a nerve underlying the stimulator. A positioning sensor, in contrast, provides an output that is based on the movement of the sensor and so does not interface with a surface, per se, but is still included within the scope of functional electronic device. Accordingly, “functional electronic device” is used broadly herein and includes any sensors or actuators having suitably thin geometry and layouts to maintain or facilitate high degree of flexibility and stretchability. Examples of functional electronic devices include: electrodes, actuators, strain sensors, motion sensors, displacement sensors, acceleration sensors, pressure sensors, force sensors, chemical sensors, pH sensors, tactile sensors, optical sensors, electromagnetic radiation sources, temperature sensors, heat sources, capacitive sensors; and combinations thereof. Tactile sensors provide an output that is proportional to a force between the sensor and the surface. An electrotactile stimulator provides an electric stimulation or actuation of a nerve underlying the stimulator, so as to provide a type of virtual reality system.

[0166] A “device component” is used broadly to refer to an individual part of a device but that, in and of itself, is insufficient to provide functional information. An “interconnect” is one example of a component, and refers to an electrically conducting structure capable of establishing an electrical connection with another component or between components. In particular, an interconnect may establish electrical contact between components that are separate. Depending on the desired device specifications, operation, and application, an interconnect is made from a suitable material. Suitable conductive materials include semiconductors and metallic conductors. Another useful device component is a thin nanomembrane, which may form part of a diode. Accordingly, a functional electronic device may be characterized as made up of a device component.

[0167] Other components include, but are not limited to, thin film transistors (TFTs), transistors, diodes, electrodes, integrated circuits, circuit elements, control elements, photovoltaic elements, photovoltaic elements (e.g. solar cell), sensors, light emitting elements, actuators, piezoelectric elements, receivers, transmitters, microprocessors, transducers, islands, bridges and combinations thereof. Components may be connected to one or more contact pads as known in

the art, such as by metal evaporation, wire bonding, and application of solids or conductive pastes, for example, thereby forming device islands. Electronic devices of the invention may comprise one or more components, optionally provided in an interconnected configuration.

[0168] “Electronic device” generally refers to a device incorporating a plurality of components and functional electronic devices, and includes large area electronics, printed wire boards, integrated circuits, arrays, biological and/or chemical sensors, physical sensors (e.g., temperature, strain, etc.), nanoelectromechanical systems, microelectromechanical systems, photovoltaic devices, communication systems, medical devices, optical devices and electro-optic devices. An electronic device may sense a property of the surface and/or may control a property of the surface.

[0169] “Sensing” and “sensor” refers to a functional electronic device or device component useful for detecting the presence, absence, amount, magnitude or intensity of a physical, biological state, and/or chemical property. Useful electronic device components for sensing include, but are not limited to electrode elements, chemical or biological sensor elements, pH sensors, temperature sensors, tactile sensors, strain sensors, mechanical sensors, position sensors, optical sensors and capacitive sensors. Useful functional electronic devices include various device components operably arranged to provide electrodes for detecting adjacent electric potential, sensors for detecting a biological condition (e.g., disease state, cell type, cell condition) or a chemical, pH, temperature, pressure, position, electromagnetic radiation (including over desired wavelengths such as associated with a fluorescent dye injected into tissue), electric potential.

[0170] “Actuating” and “actuator” refers to a functional electronic device or device component useful for interacting with, stimulating, controlling, or otherwise affecting an external structure, material or fluid, for example a target tissue that is biological tissue. Useful actuating elements include, but are not limited to, electrode elements, electromagnetic radiation emitting elements, light emitting diodes, lasers and heating elements. Functional electronic devices include actuators that are electrodes for providing a voltage or current to a tissue, sources of electromagnetic radiation for providing electromagnetic radiation to a tissue, such LEDs. Actuators also include ablation sources for ablating tissue, thermal sources for heating tissue, displacement sources for displacing or otherwise moving a tissue, reservoirs of biologics or chemicals for releasing biologics or chemicals to affect biological function, such as a biological response including cell death, cell proliferation, or cell therapy by application of biologics or chemicals. An actuator may be an electrotactile sensor.

[0171] A “tactile sensor” refers to a transducer that is sensitive to touch, such as by transducing force or pressure into a voltage output from the sensor. An “electrotactile stimulator” refers to an electronic device that electrically stimulates nerves of the skin to simulate a sensation, and may be classified as an actuator.

[0172] “Semiconductor” refers to any material that is an insulator at a very low temperature, but which has an appreciable electrical conductivity at a temperature of about 300 Kelvin. In the present description, use of the term semiconductor is intended to be consistent with use of this term in the art of microelectronics and electronic devices. Useful semiconductors include those comprising elemental

semiconductors, such as silicon, germanium and diamond, and compound semiconductors, such as group IV compound semiconductors such as SiC and SiGe, group III-V semiconductors such as AlSb, AlAs, AlN, AlP, BN, BP, BAs, GaSb, GaAs, GaN, GaP, InSb, InAs, InN, and InP, group III-V ternary semiconductor alloys such as $Al_xGa_{1-x}As$, group II-VI semiconductors such as CsSe, CdS, CdTe, ZnO, ZnSe, ZnS, and ZnTe, group I-VII semiconductors such as CuCl, group IV-VI semiconductors such as PbS, PbTe, and SnS, layer semiconductors such as PbI_2 , MoS_2 , and GaSe, oxide semiconductors such as CuO and Cu_2O . The term semiconductor includes intrinsic semiconductors and extrinsic semiconductors that are doped with one or more selected materials, including semiconductors having p-type doping materials and n-type doping materials, to provide beneficial electronic properties useful for a given application or device. The term semiconductor includes composite materials comprising a mixture of semiconductors and/or dopants. Specific semiconductor materials useful for some embodiments include, but are not limited to, Si, Ge, Se, diamond, fullerenes, SiC, SiGe, SiO, SiO_2 , SiN, AlSb, AlAs, AlIn, AlN, AlP, AIS, BN, BP, BAs, As_2S_3 , GaSb, GaAs, GaN, GaP, GaSe, InSb, InAs, InN, InP, CsSe, CdS, CdSe, CdTe, Cd_3P_2 , Cd_3As_2 , Cd_3Sb_2 , ZnO, ZnSe, ZnS, ZnTe, Zn_3P_2 , Zn_3As_2 , Zn_3Sb_2 , $ZnSiP_2$, CuCl, PbS, PbSe, PbTe, FeO, FeS_2 , NiO, EuO, EuS, PtSi, TlBr, $CrBr_3$, SnS, SnTe, PbI_2 , MoS_2 , GaSe, CuO, Cu_2O , HgS, HgSe, HgTe, HgI_2 , MgS, MgSe, MgTe, CaS, CaSe, SrS, SrTe, BaS, BaSe, BaTe, SnO_2 , TiO, TiO_2 , Bi_2S_3 , Bi_2O_3 , Bi_2Te_3 , BiI_3 , UO_2 , UO_3 , $AgGaS_2$, $PbMnTe$, $BaTiO_3$, $SrTiO_3$, $LiNbO_3$, La_2CuO_4 , $La_{0.7}Ca_{0.3}MnO_3$, $CdZnTe$, $CdMnTe$, $CuInSe_2$, copper indium gallium selenide (CIGS), $HgCdTe$, $HgZnTe$, $HgZnSe$, $PbSnTe$, Tl_2SnTe_5 , Tl_2GeTe_5 , AlGaAs, AlGaN, AlGaP, AlInAs, AlInSb, AlInP, AlInAsP, AlGaAsN, GaAsP, GaAsN, GaMnAs, GaAsSbN, GaInAs, GaInP, AlGaAsSb, AlGaAsP, AlGaInP, GaInAsP, InGaAs, InGaP, InGaN, InAsSb, InGaSb, InMnAs, InGaAsP, InGaAsN, InAlAsN, GaInAsSb, GaInAsSbP, and any combination of these. Porous silicon semiconductor materials are useful for aspects described herein. Impurities of semiconductor materials are atoms, elements, ions and/or molecules other than the semiconductor material(s) themselves or any dopants provided to the semiconductor material. Impurities are undesirable materials present in semiconductor materials which may negatively impact the electronic properties of semiconductor materials, and include but are not limited to oxygen, carbon, and metals including heavy metals. Heavy metal impurities include, but are not limited to, the group of elements between copper and lead on the periodic table, calcium, sodium, and all ions, compounds and/or complexes thereof.

[0173] A “semiconductor component” broadly refers to any semiconductor material, composition or structure, and expressly includes high quality single crystalline and polycrystalline semiconductors, semiconductor materials fabricated via high temperature processing, doped semiconductor materials, inorganic semiconductors, and composite semiconductor materials.

[0174] “Nanostructured material” and “microstructured material” refer to materials having one or more nanometer-sized and micrometer-sized, respectively, physical dimensions (e.g., thickness) or features such as recessed or relief features, such as one or more nanometer-sized and micrometer-sized channels, voids, pores, pillars, etc. The relief features or recessed features of a nanostructured material

have at least one physical dimension selected from the range of 1-1000 nm, while the relief features or recessed features of a microstructured material have at least one physical dimension selected from the range of 1-1000 μ m. Nanostructured and microstructured materials include, for example, thin films (e.g., microfilms and nanofilms), porous materials, patterns of recessed features, patterns of relief features, materials having abrasive or rough surfaces, and the like. A nanofilm structure is also an example of a nanostructured material and a microfilm structure is an example of a microstructured material. In an embodiment, the invention provides device comprising one or more nanostructured or microstructured inorganic semiconductor components, one or more nanostructured or microstructured metallic conductor components, one or more nanostructured or microstructured dielectric components, one or more nanostructured or microstructured encapsulating layers and/or one or more nanostructured or microstructured substrate layers.

[0175] A component may be a nanomembrane material. A “nanomembrane” is a structure having a thickness selected from the range of 1-1000 nm or alternatively for some applications a thickness selected from the range of 1-100 nm, for example provided in the form of a ribbon, cylinder or platelet. In some embodiments, a nanoribbon is a semiconductor, dielectric or metallic conductor structure of an electronic device. In some embodiments, a nanoribbon has a thickness less than 1000 nm and optionally less than 100 nm. In some embodiments, a nanoribbon has ratio of thickness to a lateral dimension (e.g., length or width) selected from the range of 0.1 to 0.0001.

[0176] “Neutral mechanical plane” (NMP) refers to an imaginary plane existing in the lateral, b, and longitudinal, l, directions of a device. The NMP is less susceptible to bending stress than other planes of the device that lie at more extreme positions along the vertical, h, axis of the device and/or within more bendable layers of the device. Thus, the position of the NMP is determined by both the thickness of the device and the materials forming the layer(s) of the device. In an embodiment, a device of the invention includes one or more inorganic semiconductor components, one or more metallic conductor components or one or more inorganic semiconductor components and one or more metallic conductor components provided coincident with, or proximate to, the neutral mechanical plane of the device. Examples of a variety of NMP systems incorporating multiple layers are provided, for example, in U.S. Pat. Pub. No. 2010/0002402 (Atty Ref 213-07), which is specifically incorporated by reference for methods of positioning NMP.

[0177] “Coincident” refers to the relative position of two or more objects, planes or surfaces, for example a surface such as a neutral mechanical plane that is positioned within or is adjacent to a layer, such as a functional layer, substrate layer, or other layer. In an embodiment, a neutral mechanical plane is positioned to correspond to the most strain-sensitive layer or material within the layer.

[0178] “Proximate” refers to the relative position of two or more objects, planes or surfaces, for example a neutral mechanical plane that closely follows the position of a layer, such as a functional layer, substrate layer, or other layer while still providing desired conformability without an adverse impact on the strain-sensitive material physical properties. “Strain-sensitive” refers to a material that fractures or is otherwise impaired in response to a relatively low

level of strain. In general, a layer having a high strain sensitivity, and consequently being prone to being the first layer to fracture, is located in the functional layer, such as a functional layer containing a relatively brittle semiconductor or other strain-sensitive device element. A neutral mechanical plane that is proximate to a layer need not be constrained within that layer, but may be positioned proximate or sufficiently near to provide a functional benefit of reducing the strain on the strain-sensitive device element when the device is conformed to a tissue surface. In some embodiments, proximate to refers to a position of a first element within 100 microns of a second element, or optionally within 10 microns for some embodiments, or optionally within 1 microns for some embodiments.

[0179] A “component” is used broadly to refer to a material or individual component used in a device. An “interconnect” is one example of a component and refers to an electrically conducting material capable of establishing an electrical connection with a component or between components. In particular, an interconnect may establish electrical contact between components that are separate and/or can move with respect to each other. Depending on the desired device specifications, operation, and application, an interconnect is made from a suitable material. For applications where a high conductivity is required, typical interconnect metals may be used, including but not limited to copper, silver, gold, aluminum and the like, and alloys. Suitable conductive materials further include semiconductors, such as silicon and GaAs and other conducting materials such as indium tin oxide.

[0180] An interconnect that is “stretchable” or “flexible” is used herein to broadly refer to an interconnect capable of undergoing a variety of forces and strains such as stretching, bending and/or compression in one or more directions without adversely impacting electrical connection to, or electrical conduction from, a device component. Accordingly, a stretchable interconnect may be formed of a relatively brittle material, such as GaAs, yet remain capable of continued function even when exposed to a significant deformatory force (e.g., stretching, bending, compression) due to the interconnect’s geometrical configuration. In an exemplary embodiment, a stretchable interconnect may undergo strain larger than 1%, optionally 10% or optionally 30% or optionally up to 100% without fracturing. In an example, the strain is generated by stretching an underlying elastomeric substrate to which at least a portion of the interconnect is bonded. For certain embodiments, flexible or stretchable interconnects include interconnects having wavy, meandering or serpentine shapes.

[0181] In the context of this description, a “bent configuration” refers to a structure having a curved conformation resulting from the application of a force. Bent structures may have one or more folded regions, convex regions, concave regions, and any combinations thereof. Useful bent structures, for example, may be provided in a coiled conformation, a wrinkled conformation, a buckled conformation and/or a wavy (i.e., wave-shaped) configuration. Bent structures, such as stretchable bent interconnects, may be bonded to a flexible substrate, such as a polymer and/or elastic substrate, in a conformation wherein the bent structure is under strain. In some embodiments, the bent structure, such as a bent ribbon structure, is under a strain equal to or less than 30%, optionally a strain equal to or less than 10%, optionally a strain equal to or less than 5% and optionally a

strain equal to or less than 1% in embodiments preferred for some applications. In some embodiments, the bent structure, such as a bent ribbon structure, is under a strain selected from the range of 0.5% to 30%, optionally a strain selected from the range of 0.5% to 10%, and optionally a strain selected from the range of 0.5% to 5%. Alternatively, the stretchable bent interconnects may be bonded to a substrate that is a substrate of a device component, including a substrate that is itself not flexible. The substrate itself may be planar, substantially planar, curved, have sharp edges, or any combination thereof. Stretchable bent interconnects are available for transferring to any one or more of these complex substrate surface shapes.

[0182] A “device component” is used to broadly refer to an individual component within an electrical, optical, mechanical or thermal device. Components include, but are not limited to, a photodiode, LED, TFT, electrode, semiconductor, other light-collecting/detecting components, transistor, integrated circuit, contact pad capable of receiving a device component, thin film devices, circuit elements, control elements, microprocessors, transducers and combinations thereof. A device component can be connected to one or more contact pads as known in the art, such as metal evaporation, wire bonding, application of solids or conductive pastes, for example. Electrical device generally refers to a device incorporating a plurality of device components, and includes large area electronics, printed wire boards, integrated circuits, device components arrays, biological and/or chemical sensors, physical sensors (e.g., temperature, light, radiation, etc.), solar cell or photovoltaic arrays, display arrays, optical collectors, systems and displays.

[0183] “Island” or “device island” refers to a relatively rigid device element or component of an electronic device comprising multiple semiconductor elements or active semiconductor structures. “Bridge” or “bridge structure” refers to stretchable or flexible structures interconnecting two or more device islands or one device island to another device component. Specific bridge structures include flexible semiconductor interconnects.

[0184] “Encapsulate” refers to the orientation of one structure such that it is at least partially, and in some cases completely, surrounded by one or more other structures, such as a substrate, adhesive layer or encapsulating layer. “Partially encapsulated” refers to the orientation of one structure such that it is partially surrounded by one or more other structures, for example, wherein 30%, or optionally 50% or optionally 90%, of the external surfaces of the structure is surrounded by one or more structures. “Completely encapsulated” refers to the orientation of one structure such that it is completely surrounded by one or more other structures. The invention includes devices having partially or completely encapsulated inorganic semiconductor components, metallic conductor components and/or dielectric components, for example, via incorporation a polymer encapsulant, such as an elastomer encapsulant.

[0185] “Barrier layer” refers to a device component spatially separating two or more other device components or spatially separating a device component from a structure, material or fluid external to the device. In one embodiment, a barrier layer encapsulates one or more device components. In embodiments, a barrier layer separates one or more device components from an aqueous solution, a biological tissue and/or a biological environment. In some embodiments, a barrier layer is a passive device component. In some

embodiments, a barrier layer is a functional, but non-active, device component. In a specific embodiment, a barrier layer is a moisture barrier. As used herein, the term “moisture barrier” refers to a barrier layer which provides protection to other device components from bodily fluids, ionic solutions, water or other solvents. In one embodiment, a barrier layer provides protection to an external structure, material or fluid, for example, by preventing leakage current from escaping an encapsulated device component and reaching the external structure, material or fluid. In a specific embodiment, a barrier layer is a thermal barrier. As used herein, the term “thermal barrier” refers to a barrier layer which acts as a thermal insulator, preventing, reducing or otherwise limiting the transfer of heat from one device component to another or from a device component to an external structure, fluid or material. Useful thermal barriers include those comprising materials having a thermal conductivity of 0.3 W/m·K or less, such as selected over the range of 0.001 to 0.3 W/m·K. In some embodiments, a thermal barrier comprises active cooling components, such as components known in the art of thermal management, such as thermoelectric cooling devices and systems. Thermal barriers also include those barriers comprising thermal management structures, such as structures useful for transporting heat away from a portion of a device or tissue; in these and other embodiments, a thermal barrier comprises thermally conductive material, for example material having a high thermal conductivity, such as a thermal conductivity characteristic of a metal.

[0186] “Biocompatible” refers to a material that does not elicit an immunological rejection or detrimental effect, referred herein as an adverse immune response, when it is disposed within an in-vivo biological environment. For example, a biological marker indicative of an immune response changes less than 10%, or less than 20%, or less than 25%, or less than 40%, or less than 50% from a baseline value when a biocompatible material is implanted into a human or animal. Alternatively, immune response may be determined histologically, wherein localized immune response is assessed by visually assessing markers, including immune cells or markers that are involved in the immune response pathway, in and adjacent to the implanted device. In an aspect, a biocompatible device does not observably change immune response as determined histologically. In some embodiments, the invention provides biocompatible devices configured for long-term implantation, such as on the order of weeks to months, without invoking an adverse immune response. The implantation does contemplate some immune response and associated scarring as may occur for any minimally invasive procedures, so long as the immune response is locally confined, transient and does not lead to large-scale inflammation and attendant deleterious effects and the implanted device does not substantially elevate the response compared to the corresponding physical trauma only.

[0187] “Bioinert” refers to a material that does not elicit an immune response from a human or animal when it is disposed within an in-vivo biological environment. For example, a biological marker indicative of an immune response remains substantially constant (plus or minus 5% of a baseline value) when a bioinert material is implanted into a human or animal. In some embodiments, the invention provides bioinert systems, devices and related methods.

[0188] “Multiplexed” refers to an electronic circuit to provide convenient control over an array of elements. For

example, PCT Pub. WO2011/084450 (126-09WO) describes multiplexing circuits in electrophysiology applications, which is specifically incorporated by reference. Other examples include, U.S. Patent Application Publication 2003/0149456 discloses a multi-electrode cardiac lead adapter which incorporates a multiplexing circuit allowing for control by a conventional single lead cardiac pacing pulse generator. Similarly, U.S. Patent Application Publication 2006/0173364 discloses a multichannel electrophysiology acquisition system which utilizes a digital multiplexing circuit build on a conventional integrated circuit.

[0189] “Ultrathin” refers to devices of thin geometries that exhibit extreme levels of bendability. In an embodiment, ultrathin refers to circuits having a thickness less than 1 μm , less than 600 nm or less than 500 nm. In an embodiment, a multilayer device that is ultrathin has a thickness less than 200 μm , less than 50 μm , or less than 10 μm .

[0190] “Thin layer” refers to a material that at least partially covers an underlying substrate, wherein the thickness is less than or equal to 300 μm , less than or equal to 200 μm , or less than or equal to 50 μm . Alternatively, the layer is described in terms of a functional parameter, such as a thickness that is sufficient to isolate or substantially reduce the strain on the electronic device, and more particularly a functional layer in the electronic device that is sensitive to strain.

[0191] “Polymer” refers to a macromolecule composed of repeating structural units connected by covalent chemical bonds or the polymerization product of one or more monomers, often characterized by a high molecular weight. The term polymer includes homopolymers, or polymers consisting essentially of a single repeating monomer subunit. The term polymer also includes copolymers, or polymers consisting essentially of two or more monomer subunits, such as random, block, alternating, segmented, grafted, tapered and other copolymers. Useful polymers include organic polymers or inorganic polymers that may be in amorphous, semi-amorphous, crystalline or partially crystalline states. Crosslinked polymers having linked monomer chains are particularly useful for some applications. Polymers useable in the methods, devices and components include, but are not limited to, plastics, elastomers, thermoplastic elastomers, elastoplastics, thermoplastics and acrylates. Exemplary polymers include, but are not limited to, acetal polymers, biodegradable polymers, cellulosic polymers, fluoropolymers, nylons, polyacrylonitrile polymers, polyamide-imide polymers, polyimides, polyarylates, polybenzimidazole, polybutylene, polycarbonate, polyesters, polyetherimide, polyethylene, polyethylene copolymers and modified polyethylenes, polyketones, poly(methyl methacrylate), polymethylpentene, polyphenylene oxides and polyphenylene sulfides, polyphthalamide, polypropylene, polyurethanes, styrenic resins, sulfone-based resins, vinyl-based resins, rubber (including natural rubber, styrene-butadiene, polybutadiene, neoprene, ethylene-propylene, butyl, nitrile, silicones), acrylic, nylon, polycarbonate, polyester, polyethylene, polypropylene, polystyrene, polyvinyl chloride, polyolefin or any combinations of these.

[0192] “Elastomeric stamp” and “elastomeric transfer device” are used interchangeably and refer to an elastomeric material having a surface that can receive as well as transfer a material. Exemplary conformal transfer devices useful in some methods of the invention include elastomeric transfer devices such as elastomeric stamps, molds and masks. The

transfer device affects and/or facilitates material transfer from a donor material to a receiver material. In an embodiment, a method of the invention uses a conformal transfer device, such as an elastomeric transfer device (e.g. elastomeric stamp) in a microtransfer printing process, for example, to transfer one or more single crystalline inorganic semiconductor structures, one or more dielectric structures and/or one or more metallic conductor structures from a fabrication substrate to a device substrate.

[0193] “Elastomer” refers to a polymeric material which can be stretched or deformed and returned to its original shape without substantial permanent deformation.

[0194] Elastomers commonly undergo substantially elastic deformations. Useful elastomers include those comprising polymers, copolymers, composite materials or mixtures of polymers and copolymers. Elastomeric layer refers to a layer comprising at least one elastomer. Elastomeric layers may also include dopants and other non-elastomeric materials. Useful elastomers include, but are not limited to, thermoplastic elastomers, styrenic materials, olefinic materials, polyolefin, polyurethane thermoplastic elastomers, polyamides, synthetic rubbers, PDMS, polybutadiene, polyisobutylene, poly(styrene-butadiene-styrene), polyurethanes, polychloroprene and silicones. In some embodiments, an elastomeric stamp comprises an elastomer. Exemplary elastomers include, but are not limited to silicon containing polymers such as polysiloxanes including poly(dimethyl siloxane) (i.e. PDMS and h-PDMS), poly(methyl siloxane), partially alkylated poly(methyl siloxane), poly(alkyl methyl siloxane) and poly(phenyl methyl siloxane), silicon modified elastomers, thermoplastic elastomers, styrenic materials, olefinic materials, polyolefin, polyurethane thermoplastic elastomers, polyamides, synthetic rubbers, polyisobutylene, poly(styrene-butadiene-styrene), polyurethanes, polychloroprene and silicones. In an embodiment, a polymer is an elastomer.

[0195] “Young’s modulus” is a mechanical property of a material, device or layer which refers to the ratio of stress to strain for a given substance. Young’s modulus may be provided by the expression:

$$E = \frac{(\text{stress})}{(\text{strain})} = \left(\frac{L_0}{\Delta L} \right) \left(\frac{F}{A} \right), \quad (\text{I})$$

where E is Young’s modulus, L_0 is the equilibrium length, ΔL is the length change under the applied stress, F is the force applied, and A is the area over which the force is applied. Young’s modulus may also be expressed in terms of Lamé constants via the equation:

$$E = \frac{\mu(3\lambda + 2\mu)}{\lambda + \mu}, \quad (\text{II})$$

where λ and μ are Lamé constants. High Young’s modulus (or “high modulus”) and low Young’s modulus (or “low modulus”) are relative descriptors of the magnitude of Young’s modulus in a given material, layer or device. In some embodiments, a high Young’s modulus is larger than a low Young’s modulus, preferably about 10 times larger for some applications, more preferably about 100 times larger for other applications, and even more preferably about 1000

times larger for yet other applications. In an embodiment, a low modulus layer has a Young’s modulus less than 100 MPa, optionally less than 10 MPa, and optionally a Young’s modulus selected from the range of 0.1 MPa to 50 MPa. In an embodiment, a high modulus layer has a Young’s modulus greater than 100 MPa, optionally greater than 10 GPa, and optionally a Young’s modulus selected from the range of 1 GPa to 100 GPa. In an embodiment, a device of the invention has one or more components, such as substrate, encapsulating layer, inorganic semiconductor structures, dielectric structures and/or metallic conductor structures, having a low Young’s modulus. In an embodiment, a device of the invention has an overall low Young’s modulus.

[0196] “Inhomogeneous Young’s modulus” refers to a material having a Young’s modulus that spatially varies (e.g., changes with surface location). A material having an inhomogeneous Young’s modulus may optionally be described in terms of a “bulk” or “average” Young’s modulus for the entire material.

[0197] “Low modulus” refers to materials having a Young’s modulus less than or equal to 10 MPa, less than or equal to 5 MPa or less than or equal to 1 MPa. In an aspect, the functional layer has a low modulus and the delivery substrate has a higher Young’s modulus, such as 10 times, 100 times, or 1000 times larger than the functional layer Young’s modulus.

[0198] “Bending stiffness” is a mechanical property of a material, device or layer describing the resistance of the material, device or layer to an applied bending moment. Generally, bending stiffness is defined as the product of the modulus and area moment of inertia of the material, device or layer. A material having an inhomogeneous bending stiffness may optionally be described in terms of a “bulk” or “average” bending stiffness for the entire layer of material.

[0199] An example of a device is schematically illustrated in FIG. 9. The electronic device 10 comprises a thin elastomeric substrate 20 with an inner surface 30 and an outer surface 40. An array of functional electronic devices 50 is illustrated as supported by the inner surface 30. The array comprises various device components, such as a flexible and stretchable interconnect in a curved configuration 45. The inner surface 30 defines an enclosure 60, having a characteristic dimension such as diameter 70 or length 80 between ends 90 and 95, or volume. Interior portion 60 is considered a closed volume as the substrate 20 does not have unbound ends that freely moved. Instead, movement of ends 80 and 90 are constrained. If ends 80 and 90 are able to freely move (such as if the tube were longitudinally cut), the device is considered to have an open-tube volume. Interior portion 60 can accommodate an object having a curved surface, even an irregular shaped object such as finger. Preferably, diameter 70 is slightly smaller than the maximum diameter of the object that is being received by the interior portion 60. Such a size difference requires the substrate 20 to stretch to receive the object, thereby ensuring tight conformal contact between the substrate 20, functional electronic devices 50, and the object surface within interior portion 60. For clarity, devices 50 are not shown on the outer surface 40. As explained further in Example 1, however, inner surface devices 50 may be provided by first printing functional electronic devices to the outer surface 40. The substrate surfaces may then be physically flipped, with the outer becoming the inner, and vice versa, to obtain the electronic device 10 illustrated in FIG. 9.

Example 1: Silicon Nanomembranes for Fingertip Electronics

[0200] This example relates to the use of semiconductor nanomaterials, advanced fabrication methods and unusual device designs for a class of electronics capable of integration onto the inner and the outer surfaces of thin, elastomeric sheets in closed-tube geometries, specially formed for mounting on the fingertips. Multifunctional systems of this type allow electrotactile stimulation with electrode arrays multiplexed using silicon nanomembrane (Si NM) diodes, high-sensitivity strain monitoring with Si NM gauges, and tactile sensing with elastomeric capacitors. Analytical calculations and finite element modeling of the mechanics quantitatively capture the key behaviors during fabrication/assembly, mounting and use. The results provide design guidelines that highlight the importance of the NM geometry in achieving the required mechanical properties. This type of technology is compatible with applications ranging from human-machine interfaces to 'instrumented' surgical gloves and many others.

[0201] Electrotactile stimulators and tactile sensors are of interest as bi-directional information links between a human operator and a virtual environment, in a way that could significantly expand function in touch-based interfaces to computer systems, with applications in simulated surgery, therapeutic devices, robotic manipulation and others [1-5]. Electrotactile stimulation allows information to be presented through the skin, as an artificial sensation of touch, commonly perceived as a vibration or tingling feeling [6,7]. Such responses manifest through the excitation of cutaneous mechanoreceptors as a result of passage of a suitably modulated electrical current into the tissue [8]. Developed originally in the 1950's and further advanced in the 1970's, electrotactile stimulation has been traditionally explored for programmable braille readers and displays for the visually impaired as well as for balance control in individuals who suffer from vestibular disorders [5,9-12]. Tactile sensors, on the other hand, measure pressure created by physical contact, in a way that provides complementary information for potential use in feedback loops with the electrotactile process. Additional classes of sensors that can be important in this context include those for motion and temperature. Incorporating such technologies into a conformal, skin-like device capable of intimate, non-invasive mounting on the fingertips might, therefore, represent a useful achievement. Recent advances in flexible and stretchable electronics create opportunities to build this type of device [13-17].

[0202] Disclosed herein are materials, fabrication strategies and device designs for ultrathin, stretchable silicon-based electronics and sensors that can be mounted on the inner and outer surfaces of elastomeric closed-tube structures for integration directly on the fingertips. The active components and interconnects incorporate advanced mechanics designs, capable of accommodating large strains induced not only by natural deformations of the tubes during use, but also during a critical step in the fabrication process in which the tubes, specially formed to match the shapes of fingertips, are flipped inside-out. This 'flipping-over' process allows devices initially mounted on the outer surface of the tube to be reversed to the inner surface, where they can press directly against the skin when mounted on the fingers. Analytical calculations and finite element modeling (FEM) provide quantitative insights into design layouts that avoid plastic deformation or fracture. We demonstrate these con-

cepts in multifunctional fingertip devices that include electrotactile electrode arrays multiplexed with Si nanomembrane (NM) diodes, strain sensors based on Si NM gauges, and tactile sensor arrays that use capacitors with low-modulus, elastomeric dielectrics.

[0203] FIG. 1 schematically illustrates steps for integrating devices based on Si NMs in stretchable, interconnected geometries with elastomeric substrates, following adapted versions of procedures described elsewhere [13,18]. The fabrication uses a Si wafer with a 100 nm thick coating of polymethylmethacrylate (PMMA) as a temporary substrate for the initial parts of the process. A layer of polyimide (PI; 1.25 μm thick) formed by spin coating a poly (amic acid) precursor and baking in an inert atmosphere at 250° C., serves as the support for the devices. Electronically active materials are deposited (e.g. metallization) or transfer printed (e.g. Si NMs) onto the PI and patterned by photolithography and etching. Another layer of PI (1.25 mm thick) spin cast and cured on top of the device layers provides encapsulation and locates the devices near the neutral mechanical plane (NMP). Next, patterned reactive ion etching through the entire multilayer stack (i.e. PI/devices/PI) defines an open mesh structure. This same process removes PI in regions of the electrotactile stimulation electrodes, to allow direct contact with the skin. Immersion in an acetone bath washes away the underlying PMMA, thereby allowing the entire mesh to be lifted off, in a single piece, onto the surface of a flat slab of polydimethylsiloxane (PDMS), using procedures described previously [19,20]. Evaporating a layer of SiO₂ onto the mesh/PDMS and exposing the silicon target substrate (Ecoflex 0030, Smooth-On, Inc.) to UV-ozone (to creating reactive —OH groups the surface) enables bonding between the two upon physical contact [21]. (Low pressures avoid contact between the PDMS and the finger-tube, thereby allowing bonding only to the mesh.) Removal of the stamp completes the transfer process, as shown in FIG. 1c.

[0204] The electrotactile electrodes use 600 nm thick layers of Au in a concentric design, consisting of an inner disk (400 μm radius) surrounded by an outer ring (1000 μm radius) with a 250 μm wide gap between the two. Interconnects consist of 100 μm wide traces of Au in serpentine geometries (radii of curvature \sim 800 μm); these traces connect the electrotactile electrodes to Si NM diodes (lateral dimensions of 225 μm ×100 μm and thicknesses of 300 nm). Two layers of Au interconnects (200 nm and 600 nm thick), isolated by a 1.25 μm PI layer and connected through etched PI vias, establish a compact wiring scheme with overlying interconnects. The 600 nm thick Au interconnect layer allowed robust electronic contact though the PI vias. The strain gauge arrays consist of four Si NMs (strips with lateral dimensions of 1 mm×50 μm and thicknesses of 300 nm) electrically connected by 200 nm thick, 60 μm wide Au traces patterned in serpentine shapes (radii of curvature \sim 400 μm). The tactile sensors use 200 nm thick Au electrodes and interconnects in the geometry of the electrotactile arrays but with the concentric electrode pairs replaced by single, disc-shaped electrodes (radii \sim 1000 μm).

[0205] The Ecoflex substrates, which we refer to as finger-tubes, adopt three dimensional forms specifically matched to those of fingers on a plastic model of the hand. The fabrication involves pouring a polymer precursor to Ecoflex onto a finger of the model and curing at room temperature for 1 hour, to create a conformal sheet with \sim 125 μm thickness.

Pouring a second coating of precursor onto this sheet and curing for an additional 1 hour doubles the thickness; repeating this process 4 times results in a thickness of ~ 500 μm . Removing the Ecoflex from the model and completing the cure by heating at 70°C . for 2 hours forms a free standing structure, i.e. a finger-tube, like the one illustrated in FIG. 2. Ecoflex is an attractive material for this purpose because it has a low modulus (~ 60 kPa) and large fracture strain ($\sim 900\%$). The former allows soft, intimate contact with the skin; the latter enables the ‘flipping-over’ process referred to previously, and described in quantitative detail in a following section. Transfer printing delivers the device mesh structure to the outer surface of the finger-tube, while pressed into a flattened geometry (FIG. 2b). The entire integrated system is then flipped inside-out, to move the mesh from the outer to the inner surface of the tube, as shown in FIG. 2c,d. Multifunctional devices incorporate electro-tactile stimulators on the inside, and strain gauge arrays and tactile sensors on the outside.

[0206] Device designs described previously have the advantage that they are conformal to the finger, in a way that naturally presses the electronics on the interior surface of the finger-tube (in this case the electro-tactile stimulating electrodes) into intimate contact with the skin. The flipping-over process represents a critical step, enabled by careful design of the mechanics in the device mesh. Quantitative mechanics modeling provides important insights. The finger-tube can be approximated as a self-equilibrated, axisymmetric tube with two dimensional symmetry. Energy minimization using linear elastic shell theory determines the resulting shapes. FIG. 3a shows analytical and FEM results for an Ecoflex cylinder with radius (R_{radial}) of 7.5 mm and thickness of 500 μm when bent back on itself, at a mid-way point during the flipping-over process. The minimum axial radius of curvature (R_{axial}) of 596 μm , as indicated in FIG. 3a, defines the location of maximum induced strain as the tube is flipped over. The maximum strains on the inner and outer surfaces in this configuration, as shown in the color map of FIG. 3b, are $\sim 30\text{-}40\%$ (see supplementary file at stacks.iop.org/Nano). The device mesh structures must, therefore, be able to accommodate strains in this range. This requirement is non-trivial for systems like the ones described here, due to their incorporation of brittle materials such as silicon (fracture strain $\sim 1\%$).

[0207] Circuit layouts, guided by theory, can be identified to satisfy these requirements. As an example, FIG. 3c provides a diagram of a multiplexed electro-tactile array in a mesh configuration with narrow, serpentine interconnects. The orange and blue regions correspond to Au layers separated by layers of PI, respectively; the red regions indicate Si NM (300 nm thick) diodes in a PIN (p-doped/intrinsic/n-doped) configuration. The short dimensions of the diodes lie parallel to the flipping-over direction, to minimize strains in the Si during this process. These optimizations lead to maximum calculated strains that are only 0.051%, 0.10%, and 0.040% for the Au, PI, and the Si, respectively (see FIG. 3d). The computed position of the NMP also appears in FIG. 3d. Since the moduli of the device layers are several orders of magnitude larger than that of Ecoflex, the location of the NMP plane is largely independent of the Ecoflex. Appropriate selection of the thicknesses of the PI layers allows the NMP to be positioned at the location of the Si NMs, thereby minimizing the induced strains in this brittle material [21, 22]. The thicknesses of the Si NM diodes influences the

maximum strains that they experience, as shown in analytical calculations of FIG. 3f. A minimum occurs at the thickness that places the NMP at the shortest distance from the Si NM diode (i.e. h_{NMP}). The position of this minimum can also be adjusted by changing the thicknesses of the PI layers, for example. Further reductions in strain can be realized by reducing the lengths of the devices. Implementing designs that incorporate these considerations and exploiting interconnects with optimized serpentine layouts ensures robust device behavior throughout the fabrication sequence. For example, FIG. 3e shows negligible change in the I-V characteristics (Agilent 4155C semiconductor parameter analyzer) of a Si NM diode before and after the flipping-over process.

[0208] Experimental results demonstrate expected functionality in the electro-tactile arrays. FIG. 4a shows the perception of touch on a dry human thumb as a function of voltage and frequency, applied between the inner dot and outer ring electrodes (FIG. 3d). Stimulation used a monophasic, square-wave with 20% duty cycle, generated using a custom setup. The inset provides an image of a device, with connection to external drive electronics via a flexible anisotropic conductive film (ACF). The required voltage for sensation decreases with increasing frequency, consistent with equivalent circuit models of skin impedance that involve resistors and capacitors connected in parallel. The absolute magnitudes of these voltages depend strongly on the skin hydration level, electrode design, and stimulation waveform [23]. FIG. 4b shows I-V characteristics of an electro-tactile electrode pair while in contact with a hydrated human thumb, measured through a multiplexing diode. At high positive voltages, the resistance of the diode is negligible compared to the skin; here, the slope of the I-V characteristics yield an estimate of the resistance of the skin-electrode contact plus the skin. The value (~ 40 k Ω) is in a range consistent with measurements using conventional devices [24,25]. The diode is stable to at least 20 V, corresponding to currents of 0.25 mA, which is sufficient for electro-tactile stimulation on the skin and tongue [2,6,7].

[0209] These diodes enable multiplexed addressing, according to an approach that appears schematically in FIG. 4c. Each unit cell consists of one diode and one electro-tactile electrode pair. FIG. 4d presents a table of the inputs required to address each of the six electro-tactile channels. For example, channel S_{DA} can be activating by applying a high potential (+5 V) to inputs A and E and a low potential (0 V) to inputs B, C, and D, thereby yielding a +5 V bias across the outer ring (+5 V) and inner ring electrode (0 V) of this channel. This configuration forward biases the Si NM diode, which results in stimulation current, as shown in FIG. 4b. At the same time, channels S_{EB} and S_{EC} experience a bias of -5 V across the electrodes but in these cases the Si NM diodes are reverse biased, thus preventing stimulating current. Channels S_{DE} , S_{DC} , and S_{EA} have the same potential on the inner and outer electrodes, resulting in zero bias. Electrical isolation of adjacent channels is a consequence of inner to outer electrode separations (250 μm) that are small compared to the distances between channels (6000 μm). Advanced multiplexing schemes that use several diodes per stimulation channel, or active transistors, are compatible with the fabrication process and design principles outlined here.

[0210] FIG. 5 shows a set of straight, uniformly doped Si NMs as strain gauges addressed with interconnects in a

mesh geometry. FEM calculations summarized in FIG. 5 reveal strain profiles in a 1×4 array of gauges (vertical strips; yellow dashed box and upper inset highlights an individual device) on Ecoflex, under a uniaxial in-plane strain of 10%. These results show that the overall strain is mostly accommodated by changes in the shapes of the serpentine interconnects and, of course, the Ecoflex itself. The Si NM gauges experience strains ($\sim 10^{-3}$) that are ten times lower than the applied strain, as shown in the inset in FIG. 5a.

[0211] The ability to use Si NMs as high performance strain gauges in stretchable forms results from the strong piezoresistance properties of Si, combined with serpentine layouts. These characteristics, taken together, determine the fractional change in resistance per applied strain. The associated effective gauge factor (GF_{eff}) can be related to the intrinsic gauge factor of a silicon gauge, $GF_{Si} = \Delta R / (R \epsilon_{Si})$ where ΔR is the change in resistance, R is the initial resistance, and ϵ_{Si} is the strain in the silicon, by the following expression $GF_{eff} = GF_{Si} (\epsilon_{Si} / \epsilon_{app})$ where ϵ_{app} is the strain applied to the overall, integrated system. The designs reported here yield values of $\epsilon_{Si} / \epsilon_{app}$ that are much smaller than one, specifically to avoid fracture-inducing strains in the Si during fabrication, mounting and use over physiologically relevant ranges of strain. FIG. 5b shows experimentally measured values of ΔR (evaluation at 1 V, using an Agilent 4155C semiconductor parameter analyzer) as a function of ϵ_{app} , which corresponds to $GF_{eff} - 1$. By fitting the experimental and FEM results to FIG. 5b, the GF_{Si} is ~ 95 , consistent with a recent report on Si NM strain gauges, with otherwise similar designs, on flexible sheets of plastic [26]. We emphasize that device design parameters, such as the size of the gauge and the dimensions of the serpentine interconnects, enable engineering control over GF_{eff} from values as large as GF_{Si} to those that are much smaller, with a correspondingly increased range of strains over which measurements are possible.

[0212] FIG. 5c shows a strain gauge array on a finger-tube located near the knuckle region of the thumb, in straight (I) and bent (II) positions. Upon bending, the gauges experience tensile strain, resulting in an increase in resistance, as shown for three bending cycles in FIG. 5d. The relative resistance changes suggest that the strain associated with bending reaches $\sim 6\%$. As expected, side-to-side motions induced no changes. FIG. 5e shows a similar array on a thin sheet of Ecoflex, mounted near the metacarpal region of the thumb. Here, the device adheres to the skin by van der Waals interactions, similar to mechanisms observed in epidermal electronic systems [13]. The images in FIG. 5e correspond to the thumb in straight (III) and sideways deflected (VI) positions. The changes in resistance for the two gauges on opposite ends of the 1×4 array for three side-to-side cycles of motion appear in FIG. 5f. For each cycle, the change in resistance of the rightmost gauge indicates compressive strain; the leftmost indicates corresponding tensile strain. The results suggest that arrays of gauges can be used to identify not only the magnitude but also the type of motion.

[0213] As a final demonstration, we built a type of tactile (pressure) sensor suitable for integration on the finger-tube platform. The devices exploit changes in capacitance associated with opposing electrodes on the inner and outer surfaces of the Ecoflex. Applied pressure decreases the thickness of the Ecoflex, thereby increasing the capacitance of this structure. Here, layouts like those for the electro-tactile devices serve as inner electrodes; a mirror image of this

array mounted in an aligned configuration on the outer surface defines a collection of parallel plate capacitors with the Ecoflex as the dielectric. An array of such devices on the anterior surface of a model of the hand appears in FIG. 6a. FIGS. 6b and 6c show images of the inner and outer electrode arrays. The relative change in capacitance with applied pressure for a representative device appears in FIG. 6d (black symbols). Here, capacitance was measured (Agilent E4980A LCR meter) as a function of pressure applied with a series of weights mounted on a platform with a constant contact area, taking care to minimize effects of parasitic capacitances and to eliminate ground loops. Approximately linear behavior is observed over the range studied, consistent with simple mechanical models, $\Delta C / C_o = P / (E_{Ecoflex} - P)$, where ΔC is the capacitance change, C_o is the initial capacitance, P is the applied pressure, and $E_{Ecoflex}$ is the effective Ecoflex modulus. This simple model assumes no electrostriction or strain induced changes in dielectric force (FIG. 6d, black line). Due to the Poisson effect, the devices also respond to in-plane strains ($\epsilon_{applied}$), as shown in FIG. 6d (red), consistent with the simple model $\Delta C / C_o = [(EA)_{system} / (EA)_{electrodes}] \nu \epsilon_{applied}$ where the Poisson's ratio (ν) is 0.496, and $(EA)_{system}$ and $(EA)_{electrodes}$ are the tensile stiffness of the system and electrodes respectively. This type of technology provides a simple alternative to recently reported devices that offer similar functionality, but on flexible substrates, and based on conductive elastomers, elastomeric dielectrics, or compressible gate dielectrics in organic transistors. [14, 16, 18, 27, 28].

[0214] The results presented here establish some procedures and design rules for electronics and sensors that can be mounted conformally onto the fingers. Other appendages of the body can be addressed in similar manner. Furthermore, most of the considerations in mechanics and fabrication are agnostic to the specific device functionality or mounting locations. As a result, many of these concepts can be applied generally, to other types of systems and modes of use. Future challenges include the development of capabilities for wireless power supply and data transfer.

Example 2: Methods of Making the Electronic Devices

[0215] 1. Electrotactile Arrays:

[0216] a. Cut 1'×1' SOI wafers ((110), 300 nm Si) and clean with acetone and IPA.

[0217] b. Form a 900 nm layer of SiO₂ by PECVD as p-dope diffusion mask.

[0218] c. Pattern diffusion mask by: i. Pattern photoresist (PR) AZ5214: Spin coat PR AZ5214 (3000 rpm, 30 s), pre-bake (110° C., 1 min), align mask and expose, develop with MIF327 (40 s), post-bake (110° C., 3 min). ii. Wet etch with buffered oxide etchant (BOE) (NH₄F:HF=6:1) for 1.5 min and remove PR with acetone.

[0219] d. P-type doping: i. Clean wafers with Nanostrip™ (Cyantek), place next to boron doping source, and put into furnace (1000° C.) for 30 min. ii. Etch SiO₂ mask completely with HF (30 sec), and form another 900 nm layer of SiO₂ by PECVD as n-dope diffusion mask. iii. Pattern diffusion mask: Same as 1c.

[0220] e. N-type doping: i. Clean wafers with Nanostrip™, place next to phosphorous doping source at 1000° C. for 10 min. ii. Etch SiO₂ mask completely with HF (30 sec).

[0221] f. Create holes (3 μm dia., spacing 30 μm) for releasing Si film: i. Spin coat PR Shipley S1805 (3000 rpm,

30 s), pre-bake (110° C., 1 min), align mask and expose, develop with MIF327 (9 s), post-bake (110° C., 3 min). ii. Etch Si with RIE (50 mtorr, 40 sccm SF6, 100 W, 1 min).

[0222] g. Undercut oxide layer of SOI: i. Immerse wafers in HF solution for 15-20 min until the Si layer is detached from the substrate.

[0223] h. Pick up the Si film from the SOI wafer with a PDMS stamp.

[0224] i. Prepare target Si wafer: i. Spin coat Si wafer with polymethylmethacrylate (PMMA, 3000 rpm, 30 s, ~100 nm), cure at 180° C. for 1.5 min. ii. Spin coat polyimide precursor (4000 rpm, 30 s) and partially cure at 150° C. for 40 sec.

[0225] j. Transfer Si to target Si wafer: i. Press the stamp into contact with the target wafer and apply force with hands for 10 s. ii. Put stamp and target wafer on a hotplate at 110° C. and slowly release the stamp when thermal expansion of the stamp is observed. iii. Put target wafer (now with Si film) on hotplate at 150° C. for another 5 min and remove PR with acetone (2 s). iv. Bake in an inert atmosphere at 250° C. for 1 hr.

[0226] k. Si diode isolation: i. Pattern PR AZ5214. ii. Etch exposed Si with RIE (50 mtorr, 40 sccm SF6, 100 W, 1 min) and strip PR with acetone.

[0227] l. 1st Au interconnect layer: i. Deposit Cr (5 nm)/Au (200 nm) with electron beam evaporator. ii. Pattern PR AZ5214. iii. Wet etch Au and Cr. iv. Strip PR with acetone.

[0228] m. PI insulation layer with vias: i. Spin coat polyimide precursor (4000 rpm, 30 s). ii. Prebake on hotplate (150° C., 5 min). iii. Bake in an inert atmosphere at 250° C. for 1 hr. iv. Spin coat PI with PR AZ4620 (3000 rpm, 30 s), pre-bake (110° C., 1 min), align via mask and expose, develop with 3:1 diluted MIF400 (40 s). v. Etch exposed polyimide with RIE (100 W, 150 mTorr, 20 sccm O2, 20 min). vi. Strip PR with acetone.

[0229] n. 2nd Au interconnect layer: i. Deposit Cr (10 nm)/Au (600 nm) with electron beam evaporator. ii. Pattern PR AZ5214. iii. Wet etch Au and Cr. iv. Strip PR with acetone.

[0230] o. Final PI encapsulation and etch: i. Form PI layer: Same as 1n. ii. Pattern PR AZ4620. iii. Etch exposed polyimide with RIE (100 W, 150 mTorr, 20 sccm O2, 50 min) to form PI mesh structure. iv. Strip PR with acetone.

[0231] p. Transfer printing: i. Immerse device in heated acetone bath (100° C.) to undercut PMMA. ii. Press PDMS stamp into contact with the device and quickly remove to transfer device onto the stamp. iii. Deposit Cr (5 nm)/SiO2 (20 nm) with e-beam evaporator. iv. Ultra-violet/ozone (UV-O) treat the target substrate (Ecoflex finger tube) for 4 min. v. Press the PDMS stamp onto Ecoflex and remove stamp slowly.

[0232] 2. Strain Gauge Arrays:

[0233] a. Cut 1'x1' (110) SOI wafers (300 nm Si) and clean with acetone and IPA.

[0234] b. P-type doping: same as 1d with a 4 min doping time.

[0235] c. Transfer print Si to target wafer: same as 1f-j.

[0236] d. Si strain gauge isolation: same as 1k.

[0237] e. Au interconnect layer: same as 1l.

[0238] f. Final encapsulation: same as 1o with 30 min O2 RIE.

[0239] g. Transfer printing: same as 1p.

[0240] 3. Contact Sensor Array:

[0241] a. Cut 1'x1' Si wafers and clean with acetone and IPA.

[0242] b. Spin coat PMMA (3000 rpm, 30 s) as sacrificial layer.

[0243] c. Form polyimide layer as substrate: Same as 1m.

[0244] d. Au interconnect layer: same as 1l.

[0245] e. Final encapsulation: same as 2f.

[0246] f. Transfer printing to overlay with electro-tactile electrodes: same as 1p.

[0247] Summaries of various methods for making sensors and actuators useful in the devices and methods provided herein are summarized in FIGS. 10-13.

[0248] Mechanics Modeling:

[0249] Strain of the multiplexed electro-tactile arrays during the flipping-over process. The elastomeric Ecoflex finger-tube with the thickness t_{sub} is flipped over twice on the finger model with the radius R_{finger} . FIG. 8 illustrates a self-equilibrated, axisymmetric Ecoflex tube during the flipping-over process; AB represents the cylindrical portion in contact with the surface of plastic hand; the outer surface DE is also cylindrical; transition between the two can be approximated by a semi-circle BC (with radius R_1 to be determined in FIG. 8) and a sinusoidal curve CD (with half wavelength L to be determined). For the profile shown in FIG. 8, the linear elastic shell theory gives the bending energy and the membrane energy. Minimization of the total energy then gives R_1 and L . For $R_{finger}=7.5$ mm and $t_{sub}=500$ μ m, energy minimization gives the bending radius $R_1=596$ μ m and $L=2.47$ mm for the Poisson's ratio of Ecoflex $\nu=0.496$. The maximum tensile and compressive strains in Ecoflex are $\epsilon_{tensile}=34.4\%$ and $\epsilon_{compressive}=-49.5\%$, which agree well with the FEM results ($\epsilon_{tensile}=35.1\%$ and $\epsilon_{compressive}=-46.9\%$).

[0250] The multiplexed electro-tactile arrays are modeled as a composite beam with multiple layers. The bending moment and membrane force obtained from the above analytical model are imposed on the multiplexed electro-tactile arrays. This gives the analytical expressions of the maximum strain in Si and Au, which are validated by FEM for relatively long Si diodes. For relatively short Si diodes, the analytical expressions overestimate the maximum strain in Si and Au.

[0251] Mechanical analysis of the tactile (pressure) sensor: The inner dot and outer ring electrodes form pairs of parallel capacitors. The capacitance change is related to the applied pressure that results in the decrease of the thickness of Ecoflex dielectric

$$\frac{\Delta C}{C_0} = \frac{P}{E_{ecoflex} - P}, \quad (S1)$$

[0252] where: $\bar{E}_{ecoflex}=(1-\nu)E/[(1+\nu)(1-2\nu)]$ is the effective modulus of Ecoflex dielectric under uniaxial stretching, and $E=60$ kPa is the Young's modulus of Ecoflex. As shown in FIG. 6d, Eq. (51) agrees well with experiments.

[0253] For an applied tensile strain $\epsilon_{applied}$, the strain in the Ecoflex dielectric between electrodes is related to the tensile stiffness $(EA)_{system}$ of the system and tensile stiffness $(EA)_{electrodes}$ of the electrodes by $\epsilon_{applied}(EA)_{system}(EA)_{electrodes}$. The capacitance change of a single element of the pressure sensor array is also determined by the decrease of the thickness of the Ecoflex dielectric, and is given by

$$\frac{\Delta C}{C_0} = \frac{(EA)_{\text{system}}}{(EA)_{\text{electrodes}}} v_{\text{eapplied}} \quad (S2)$$

REFERENCES FOR EXAMPLES 1-2

- [0254] 1. Barfield W, Hendrix C, Bjorneseth O, Kaczmarek K A and Lotens W 1995 *Presence-Teleoperators and Virtual Environments* 4 329
- [0255] 2. Matteau I, Kupers R, Ricciardi E, Pietrini P and Ptito M 2010 *Brain Research Bulletin* 82 264
- [0256] 3. Tan H Z, Durlach N I, Reed C M and Rabinowitz W M 1999 *Perception & Psychophysics* 61 993
- [0257] 4. Sparks D W, Kuhl P K, Edmonds A E and Gray G P 1978 *Journal of the Acoustical Society of America* 63 246
- [0258] 5. Danilov Y P, Tyler M E and Kaczmarek K A 2008 *International Journal of Psychophysiology* 69 162
- [0259] 6. Kaczmarek K A, Webster J G, Bachyrita P and Tompkins W J 1991 *Ieee Transactions on Biomedical Engineering* 38 1
- [0260] 7. Lozano C A, Kaczmarek K A and Santello M 2009 *Somatosens. Mot. Res.* 26 50
- [0261] 8. Warren J P, Bobich L R, Santello M, Sweeney J D and Tillery S I H 2008 *Ieee Transactions on Neural Systems and Rehabilitation Engineering* 16 410
- [0262] 9. Bach-y-Rita P, Tyler M E and Kaczmarek K A 2003 *International Journal of Human-Computer Interaction* 15 285
- [0263] 10. Jones L A and Safter N B 2008 *Human Factors* 50 90
- [0264] 11. Vuillerme N, Pinsault N, Chenu O, Demongeot J, Payan Y and Danilov Y 2008 *Neuroscience Letters* 431 206
- [0265] 12. Vidal-Verdu F and Hafez M 2007 *Ieee Transactions on Neural Systems and Rehabilitation Engineering* 15 119
- [0266] 13. Kim D H et al. 2011 *Science* 333 838
- [0267] 14. Lipomi D J, Vosgueritchian M, Tee B C, Hellstrom S L, Lee J A, Fox C H and Bao Z 2011 *Nature Nanotech.* 6 788
- [0268] 15. Rogers J A and Huang Y G 2009 *Proc. Natl. Acad. Sci. U.S.A* 106 16889
- [0269] 16. Someya T, Sekitani T, Iba S, Kato Y, Kawaguchi H and Sakurai T 2004 *Proc. Natl. Acad. Sci. U.S.A* 101 9966
- [0270] 17. Rogers J A, Lagally M G and Nuzzo R G 2011 *Nature* 477 45
- [0271] 18. Kim D H et al. 2011 *Nat. Mater.* 10 316
- [0272] 19. Meitl M A et al. 2006 *Nat. Mater.* 5 33
- [0273] 20. Yu J and Bulovic V 2007 *Appl. Phys. Lett.* 91
- [0274] 21. Kim D H et al. 2008 *Science* 320 507
- [0275] 22. Rogers J A, Someya T and Huang Y G 2010 *Science* 327 1603
- [0276] 23. Kaczmarek K A and Haase S J 2003 *Ieee Transactions on Neural Systems and Rehabilitation Engineering* 11 9
- [0277] 24. Woo E J, Hua P, Webster J G, Tompkins W J and Pallasareny R 1992 *Medical & Biological Engineering & Computing* 30 97
- [0278] 25. Hua P, Woo E J, Webster J G and Tompkins W J 1993 *Ieee Transactions on Biomedical Engineering* 40 335

[0279] 26. Won S M et al. 2011 *Ieee Transactions on Electron Devices* 58 4074

[0280] 27. Someya T et al. 2005 *Proc. Natl. Acad. Sci. U.S.A* 102 12321

[0281] 28. Takei K et al. 2010 *Nat. Mater.* 9 821

Example 3: Appendage Mountable Electronic Devices Conformable to Biological Surfaces

[0282] One example of an appendage mountable electronic system is schematically summarized in FIGS. 14-17, including an appendage corresponding to a finger or a finger-tip. Different views of an appendage mountable electronic system 10 is provided in FIG. 14(A-C), with a top view (A), a side cross-section view (B) and a cross-section viewed from an end (C). Referring to the different views of FIG. 14, the system 10 comprises a flexible and stretchable substrate 20 having an inner surface 30 and an outer surface 40. In this example, the electronic device 50 comprises a plurality of flexible or stretchable sensors 54 supported by the outer surface 40, and a plurality of flexible or stretchable actuators 55 supported by the inner surface 30. The electronic device further comprises various components to provide desired functionality and operating characteristics. For example, FIG. 14 illustrates electrical interconnects 53 in a curved or serpentine configuration that electrically interconnect more rigid components (e.g., rigid device islands), such as electrodes 54 having an interior disk-shaped electrode positioned within and concentric to a ring-shaped electrode. The cross-sectional views provided in FIGS. 14B and 14C illustrate that electronic device 50 may be supported by the inner surface 30, the outer surface 40, or by both surfaces. Optionally, the electronic device may comprise an array of sensors 54, such as tactile sensors, supported by the outer surface and an array of stimulators 55, such as electrotactile stimulators, supported by the inner surface 30, for interfacing with a surface of an appendage.

[0283] An enclosure 60 is defined by inner surface 30. Referring to FIG. 15, enclosure 60 receives an appendage 61 such that a surface 62 of the appendage is in conformal contact with the inner surface 30 of the substrate 20. FIG. 15 illustrates electronic device 50 on the outer surface 40 that is a system 10 with outer surface supported sensors, such as tactile sensors, for assessing a tactile parameter such as contact force or pressure with external surface 63. Optionally, the substrate 20 may stretch to accommodate the appendage 61 within the enclosure 60. Optionally, the enclosure does not stretch to accommodate an appendage.

[0284] For comparison, FIG. 16 shows a system 11 having electronic devices supported on the inner surface 30 of the substrate 20. The electronic devices may be electrotactile stimulators that interface with living tissue of an appendage within the enclosure, or a sensor to measure a parameter of interest of the appendage (e.g., temperature, hydration). The panels on the right side of FIGS. 15-16 indicate an aspect where the shape of the enclosure changes upon receipt of the appendage as illustrated by an end view cross-section of the system 10. As desired, one or more barrier or encapsulation layers 21 may encapsulate at least a portion of the electronic device, such as the sensors and/or actuators, including those supported by the outer surface (illustrated in top right panel of FIG. 15) and/or those by the inner surface.

[0285] One useful aspect of outer surface mounted sensors is for interfacing with an external surface 63. For a sensor 54 that is a tactile sensor, the tactile sensor interface provides a

measure of the contact force or pressure between the sensor **54** and the external surface **63**. For other sensor types, such as temperature, optical, pH or any others disclosed herein, the sensor provides an output corresponding to the functionality of the sensor. This is generally referred to as “external interfacing” or an external interface parameter and is indicated by **64**. In contrast, referring to FIG. **16**, actuators **55** supported by the inner surface may interface with living tissue of an appendage within the enclosure. This is generally referred to as “internal interfacing” or an internal interface parameter. In an aspect, any of the systems provided herein are for external interfacing (FIG. **15**), internal interfacing (**16**), or both external and internal interfacing (combination of FIGS. **15** and **16**, as indicated by the electronic devices in FIGS. **14B** and **C**).

[**0286**] One example of a method for making any of the devices provided herein is schematically illustrated in FIG. **17**. FIG. **17A** shows an appendage mountable electronic system **10** having an electronic device **50** supported on the substrate **20** outer surface **40** with inner surface **30** defining an enclosure **60**. The enclosure **60**, may be described by a characteristic dimension such as diameter **70** or length between ends **90** and **95**, or volume of **60**. In an embodiment, diameter **70** is slightly smaller than the maximum diameter of the object that is being received by the interior portion **60**. Such a size difference requires the substrate **20** to stretch to receive the object, thereby ensuring tight conformal contact between the substrate **20**, electronic devices **50**, and the appendage surface within interior portion enclosure **60** (see, e.g., FIGS. **15-16**).

[**0287**] FIG. **17B** illustrates application of a substrate surface flipping force **210** that flips outer surface **40** to the inner surface **41** and, correspondingly, inner surface **30** to outer surface **31**, as illustrated in FIG. **17C**. FIG. **17D** indicates that new outer surface may receive another electronic device, such that a first array **271** of devices is supported by the outer surface and a second array **272** of devices is supported by the inner surface, such as to provide a multi-functional system **12**.

[**0288**] FIG. **18** is a process flow summary of one embodiment for making any of the systems disclosed herein. In step **1800** a flexible and stretchable substrate is provided, such as having an enclosure defined by the substrate inner surface. An electronic device is provided to the substrate outer surface **1810**. The device may be partially encapsulated by a barrier layer. Depending on the application of interest, an appendage may be placed in the enclosure, as outlined in **1820**. This device may then be used to interface with an object that is external to the enclosure, such as for surface sensing applications. Alternatively, if the system is for an application to interface with the appendage, flipping **1830** may be performed, so that the electronic device is on the inner surface. If only interfacing with the appendage is desired, step **1840** is followed. Alternatively, another electronic device may be provided to the outer surface as indicated in **1850**, which is optionally at least partially or completely encapsulated with a barrier layer. In this fashion, dual functionality is obtained for external and internal interfacing **1860**. In contrast, **1820** is for external interfacing only, and **1840** is for internal interfacing only. As outlined herein, any of the electronic devices are provided to a surface such as by transfer printing of various metallic and semiconductor components, preferably thin components in a layout that can accommodate bending and stretching.

[**0289**] FIG. **20** is a process flow summary of another embodiment for making any of the systems disclosed herein by providing an object **1900** that corresponds to the appendage, or model or mold thereof. An electronic device is provided to the surface of the object **1910**. A prepolymer or other substrate-precursor is cast against the object surface and the electronic device **1920**. Depending on the application of interest, the device is then ready for use **1930** or may receive another electronic device on the outer substrate **1940**. As indicated by steps **1950** **1960** and **1970**, the printing to the external surface can be before or after removal from the object provided in step **1910**.

Example 4: Tactile Sensor on External and Internal Surfaces

[**0290**] In another example, any of the systems provided herein has electronic devices on both the inner and outer surfaces, wherein the inner and outer surface devices are in communication with each other such as to functionally provide a pressure or force sensor. In one embodiment, the communication is an electrical communication for a pair of opposed electrodes. Another example of functional communication include direct electrical contact, where output from a device on one surface is provided to a device on the outer surface. In another aspect, the devices are in thermal contact with each other, such as between a heat source and a thermal or temperature sensor.

[**0291**] An aspect of the invention is a tactile sensor that provides information about contact forces or pressures based on a change in thickness of a material between two opposed electrodes. Examples include pressure sensors based on capacitance or thermal sensing. Referring to FIG. **19**, a first electronic device **610** and a second electronic device **620** are supported by inner and outer surfaces of elastomeric substrate **20**. For simplicity, only a portion of a side-view cross-section of the system is illustrated in FIG. **19**, with an enclosure volume for conformally contacting an appendage (not shown) adjacent to an array of first electronic device **610**. For simplicity, FIG. **19** exemplifies electronic devices that are electrodes **610** and **620**. Electrical interconnects **640** (first plurality of electrical interconnects) and **650** (second plurality of electrical interconnects) provide an electrical connection, either independently or in a multiplexed configuration, to each electrode. The interconnects may be in a bent configuration, such as serpentine geometry. The interconnects may be embedded within first and second encapsulation layers **660** **670**, respectively. Optionally, a barrier layer **680** is used to further electrically isolate the interconnects from each other and/or the surrounding environment. The barrier layer and encapsulation layers positions are determined in part by the desired application. For example, a barrier layer that is a thermal barrier may be positioned between a thermal source/thermal sensor and the appendage/external environment, depending on positions of the sensor and source.

[**0292**] Electronic devices, e.g., thermal sensors/sources or electrodes **610** and **620** may be spatially aligned with respect to each other and separated by elastomeric substrate **20** of a defined thickness **630**, thereby functionally forming a capacitor whose capacitance varies with thickness **630**. In this manner, a pressure or force sensor is provided that measures pressure or force based on a change in the thickness **630**. In this aspect, it is important that substrate **20** be formed of an elastic material that will change thickness in

accordance with an applied contact force or pressure. Preferably, the material is elastomeric in that its response characteristics are reversible and will compress and relax back to an uncompressed state with minimal change in resting thickness. Elastomeric materials can help provide more accurate, robust and reliable measure of force or pressure. Force and pressure are generally used interchangeably in that one can be calculated from the other based on the expression $F=P/A$, where F is the force (Newtons), P is the pressure (Pascals) and A is the area over which the pressure is applied (m^2). Functionally, a thermal-based system is similarly arranged, except decrease in thickness results in increase in temperature. Similarly, optical sources and detectors may be employed, where optical transmission is dependent on substrate thickness. In this manner, any of the systems provided herein may include any of the above-referenced pressure sensors for providing tactile information, such as a force applied to or from an external surface, including a pressure that may spatially-vary over the contact area region of the applied force.

[0293] There is tolerance with respect to the degree of alignment between the inner 610 and outer electronic devices 620, particularly as the systems are readily calibrated by applying known forces or pressures and observing the resultant change in capacitance (see, e.g., FIG. 6(d)), temperature or optical transmission. In an aspect, the substrate is at least partially translucent or transparent to facilitate alignment during printing of the outer-facing electronic devices to the outer surface with the inner-facing electronic devices.

[0294] Use of aligned electrode array pairs provides arrays of capacitors, thereby allowing detection of a force or pressure distribution over the surface of the system by virtue of spatially varying changes in substrate thickness 630 that are detected by the different capacitors.

STATEMENTS REGARDING INCORPORATION BY REFERENCE AND VARIATIONS

[0295] All references throughout this application, for example patent documents including issued or granted patents or equivalents; patent application publications; and non-patent literature documents or other source material; are hereby incorporated by reference herein in their entireties, as though individually incorporated by reference, to the extent each reference is at least partially not inconsistent with the disclosure in this application (for example, a reference that is partially inconsistent is incorporated by reference except for the partially inconsistent portion of the reference).

[0296] The terms and expressions which have been employed herein are used as terms of description and not of limitation, and there is no intention in the use of such terms and expressions of excluding any equivalents of the features shown and described or portions thereof, but it is recognized that various modifications are possible within the scope of the invention claimed. Thus, it should be understood that although the present invention has been specifically disclosed by preferred embodiments, exemplary embodiments and optional features, modification and variation of the concepts herein disclosed may be resorted to by those skilled in the art, and that such modifications and variations are considered to be within the scope of this invention as defined by the appended claims. The specific embodiments provided herein are examples of useful embodiments of the present invention and it will be apparent to one skilled in the art that

the present invention may be carried out using a large number of variations of the devices, device components, methods steps set forth in the present description. As will be obvious to one of skill in the art, methods and devices useful for the present methods can include a large number of optional composition and processing elements and steps.

[0297] When a group of substituents is disclosed herein, it is understood that all individual members of that group and all subgroups, are disclosed separately. When a Markush group or other grouping is used herein, all individual members of the group and all combinations and subcombinations possible of the group are intended to be individually included in the disclosure. Specific names of compounds are intended to be exemplary, as it is known that one of ordinary skill in the art can name the same compounds differently.

[0298] Every formulation or combination of components described or exemplified herein can be used to practice the invention, unless otherwise stated.

[0299] Whenever a range is given in the specification, for example, a physical property range, a size range, a temperature range, a time range, or a composition or concentration range, all intermediate ranges and subranges, as well as all individual values included in the ranges given are intended to be included in the disclosure. It will be understood that any subranges or individual values in a range or subrange that are included in the description herein can be excluded from the claims herein.

[0300] All patents and publications mentioned in the specification are indicative of the levels of skill of those skilled in the art to which the invention pertains. References cited herein are incorporated by reference herein in their entirety to indicate the state of the art as of their publication or filing date and it is intended that this information can be employed herein, if needed, to exclude specific embodiments that are in the prior art. For example, when composition of matter are claimed, it should be understood that compounds known and available in the art prior to Applicant's invention, including compounds for which an enabling disclosure is provided in the references cited herein, are not intended to be included in the composition of matter claims herein.

[0301] As used herein, "comprising" is synonymous with "including," "containing," or "characterized by," and is inclusive or open-ended and does not exclude additional, unrecited elements or method steps. As used herein, "consisting of" excludes any element, step, or ingredient not specified in the claim element. As used herein, "consisting essentially of" does not exclude materials or steps that do not materially affect the basic and novel characteristics of the claim. In each instance herein any of the terms "comprising", "consisting essentially of" and "consisting of" may be replaced with either of the other two terms. The invention illustratively described herein suitably may be practiced in the absence of any element or elements, limitation or limitations which is not specifically disclosed herein.

[0302] One of ordinary skill in the art will appreciate that starting materials, biological materials, reagents, synthetic methods, purification methods, analytical methods, assay methods, and biological methods other than those specifically exemplified can be employed in the practice of the invention without resort to undue experimentation. All art-known functional equivalents, of any such materials and methods are intended to be included in this invention. The terms and expressions which have been employed are used

as terms of description and not of limitation, and there is no intention that in the use of such terms and expressions of excluding any equivalents of the features shown and described or portions thereof, but it is recognized that various modifications are possible within the scope of the invention claimed. Thus, it should be understood that although the present invention has been specifically disclosed by preferred embodiments and optional features, modification and variation of the concepts herein disclosed may be resorted to by those skilled in the art, and that such modifications and variations are considered to be within the scope of this invention as defined by the appended claims.

[0303] The following patents and patent applications are hereby incorporated by reference in their entireties: U.S. Pat. Nos. 7,195,733; 7,622,367; 7,557,367; 7,799,699; 7,943,491; 7,521,292; 8,367,035; 8,217,381; 7,932,123; 7,972,875; 8,198,621; 7,704,684; 7,982,296; 8,039,847; 7,705,280; 2010/0002402; 2010/0052112; 2010/0317132; 2012/0105528; 2012/0157804; 2008/0055581; 2011/0230747; 2011/0187798; 2013/0072775; Ser. No. 13/624,096 (filed Sep. 21, 2012).

1-125. (canceled)

126. A method of making appendage mountable electronic system, said method comprising the steps of:

providing a flexible or stretchable substrate having an initially inner facing surface defining an original enclosure; and an initially outer facing surface;

transfer printing a flexible or stretchable electronic device comprising one or more sensors, actuators or both to said initially outer facing surface of said flexible or stretchable substrate; said sensors, actuators or both comprising one or more inorganic semiconductor components, one or more metallic components, or one or more inorganic semiconductor components and one or more metallic components; wherein at least a portion of said inorganic semiconductor components, metallic components or both has a thickness less than or equal to 500 microns; and

flipping said flexible or stretchable substrate so that after flipping the initially outer facing surface becomes a subsequently inner facing surface defining a final enclosure for receiving an appendage and the original inner facing surface becomes a subsequently outer facing surface, thereby providing said electronic device on the subsequently inner facing surface;

wherein after said step of flipping said flexible or stretchable substrate said flexible or stretchable electronic device remains functional.

127-138. (canceled)

139. An appendage mountable electronic system, said system comprising:

an elastomeric substrate having an inner surface and an outer surface, wherein the inner surface defines an enclosure capable of receiving an appendage having a curved surface, and the elastomeric substrate has a resting thickness that is less than 10 mm;

a first electronic device supported by the inner surface;

a second electronic device supported by the outer substrate, wherein the first and second electronic devices are in an opposed configuration with respect to each other and separated by a thickness of the elastomeric substrate to form a sensor whose output varies as a function of elastomeric substrate thickness;

each of the first and second electronic devices comprises one or more inorganic semiconductor components, one or more metallic components, or one or more inorganic semiconductor components and one or more metallic components, having a thickness less than 1 mm and a lateral dimension less than 5 mm.

140. The system of claim **139**, wherein the sensor is a pressure sensor comprising a pair of spatially aligned electrodes with a first electrode supported by the inner surface and a second electrode supported by the outer surface, wherein the pair of electrodes are in electrical communication with each other and having a capacitance between the pair of electrodes that varies with elastomeric substrate thickness between the pair of electrodes.

141. The system of claim **140**, comprising an array of first electrodes and an array of second electrodes, wherein the array of first electrodes and the array of second electrodes are spatially aligned with each other to form an array of capacitors, each capacitor having a pair of electrodes separated by a thickness of the elastomeric substrate, each individual member of the array of capacitors having a capacitance that independently varies as a function of the elastomeric substrate thickness between the electrodes of the individual member of the array of capacitors.

142. The system of claim **141**, further comprising a first plurality of electrical interconnects to electrically connect each member of the array of first electrodes and a second plurality of electrical interconnects to electrically connect each member of the second array of electrodes, wherein the electrical interconnects are in a serpentine configuration.

143. The system of claim **142**, wherein the first plurality of electrical interconnects is encapsulated by a first encapsulation layer supported by the elastomeric substrate inner surface and the second plurality of electrical interconnects is encapsulated by a second encapsulation layer supported by the elastomeric substrate outer layer.

144. The system of claim **142**, further comprising a barrier layer to electrically isolate the first plurality of electrical interconnects from the second plurality of electrical interconnects.

145. The system of claim **140**, wherein an applied pressure to the elastomeric substrate decreases substrate thickness between the pair of electrodes, thereby increasing the capacitance.

146. The system of claim **139**, wherein the first and second electronic devices are in thermal communication with each other, wherein one of the electronic devices is a thermal source and the electronic device is a thermal detector that measures a temperature, and a change in elastomeric substrate thickness between the thermal source and the thermal detector changes the temperature measured by the thermal detector.

147-149. (canceled)

150. An appendage mountable electronic system, said system comprising:

a flexible or stretchable substrate having an inner surface and an outer surface, wherein the inner surface defines an enclosure capable of receiving an appendage having a curved surface; and

a flexible or stretchable electronic device comprising one or more sensors, supported by the inner surface of said flexible or stretchable substrate; said sensors comprising one or more inorganic semiconductor components, one or more metallic components, or one or more

inorganic semiconductor components and one or more metallic components; wherein at least a portion of said inorganic semiconductor components, metallic components or both have a thickness less than or equal to 500 microns;

wherein said flexible or stretchable substrate and said electronic device provide a net bending stiffness of the system low enough such that the inner surface of the substrate is capable of establishing conformal contact with a surface of said appendage provided within said enclosure during use.

151. The system of claim **150** configured for mounting to a fingertip or any portion thereof.

152. The system of claim **151**, having a footprint surface area that is between 0.5 cm^2 and 2 cm^2 .

153. The system of claim **151**, that is incorporated into a glove finger or a glove fingertip.

154. The system of claim **150**, further comprising one or more actuators for tissue stimulation, wherein said one or more actuators are supported by the inner surface of said flexible or stretchable substrate; said actuators comprising one or more inorganic semiconductor components, one or more metallic components, or one or more inorganic semiconductor components and one or more metallic components; wherein at least a portion of said inorganic semiconductor components, metallic components or both have a thickness less than or equal to 500 microns.

155. The system of claim **154**, wherein said actuators comprise electroactile stimulators and said sensors comprise tactile sensors.

156. The system of claim **155**, further comprising a wireless transmitter for bi-directional communication between the system and a virtual environment.

157. The system of claim **150**, wherein said electronic device comprises a stretchable or flexible electrode array comprising a plurality of electrodes, multiplex circuitry and amplification circuitry.

158. The system of claim **150**, wherein said sensors comprise tactile sensors, motion sensors, temperature sensors, or any combination thereof.

159. The system of claim **150**, further comprising a wireless transmitter connected to said electronic device.

160. The system of claim **150**, further comprising a wireless power source connected to said electronic device.

161. The system of claim **139**, wherein the system is configured to adhere to a skin layer by van der Waals interactions during use.

162. The system of claim **139**, wherein said system is stretchable and configured to conformally contact with a living tissue surface during use.

163. The system of claim **139**, having:

a net bending stiffness less than or equal to $1 \times 10^8 \text{ GPa } \mu\text{m}^3$; and/or

a net flexural rigidity less than or equal to $1 \times 10^{-4} \text{ Nm}$.

* * * * *

专利名称(译)	附件可安装的电子设备适合表面		
公开(公告)号	US20170181704A1	公开(公告)日	2017-06-29
申请号	US15/375514	申请日	2016-12-12
申请(专利权)人(译)	伊利诺伊大学的董事会		
当前申请(专利权)人(译)	伊利诺伊大学的董事会		
[标]发明人	ROGERS JOHN A YING MING BONIFAS ANDREW LU NANSHU		
发明人	ROGERS, JOHN A. YING, MING BONIFAS, ANDREW LU, NANSHU		
IPC分类号	A61B5/00 A61B5/01 H05K1/18 A61N1/04 H05K3/30 H05K1/16 H05K1/11 A61B42/10 H05K1/02		
CPC分类号	A61B5/6806 H05K2201/055 A61B5/01 A61B5/4875 H05K1/189 H05K1/0283 H05K3/303 H05K1/162 H05K1/11 A61N1/0456 A61N1/0476 A61B2562/0271 H05K2201/10151 H05K2201/10098 H05K2201/0133 A61B42/10 A61B5/1125 A61B5/483 A61B5/6826 A61B5/6843 A61B5/7455 A61B34/35 A61B34/76 A61B2034/741 A61B2505/05 A61B2562/0233 A61B2562/0247 A61B2562/0261 A61B2562/028 A61B2562/0285 A61B2562/029 A61B2562/046 A61B2562/12 A61B2562/164 A61B2562/227 H01L23/5388 H01L2224/95 H01L2224/95001 H01L2924/0002 Y10T29/49124 A61B5/04 A61B5/053 A61N1/04 A61N1/36 A61N1/3603 H05K7/02 Y10S439/909 A41D19/015 H05K3/0014 H01L2924/00		
优先权	61/794004 2013-03-15 US 61/636527 2012-04-20 US 61/618371 2012-03-30 US		
其他公开文献	US10052066		
外部链接	Espacenet USPTO		

摘要(译)

公开了附件可安装的电子系统和用于覆盖和贴合附肢表面的相关方法。柔性或可拉伸的基底具有用于接收附肢的内表面，包括具有弯曲表面的附肢，以及可从外表面接近的相对的外表面。根据感兴趣的应用，可拉伸或柔性电子设备由基板内表面和/或外表面支撑。与基板结合的电子装置提供净弯曲刚度，以促进内表面和外壳内提供的附件表面之间的共形接触。在一个方面，该系统能够进行表面翻转而不会不利地影响电子设备功能，例如包括传感器阵列，致动器或传感器和致动器两者的电子设备。

