



US 20150342523A1

(19) **United States**

(12) **Patent Application Publication**
BAIK et al.

(10) **Pub. No.: US 2015/0342523 A1**
(43) **Pub. Date: Dec. 3, 2015**

(54) **STRETCHABLE THERMOELECTRIC MATERIAL AND THERMOELECTRIC DEVICE INCLUDING THE SAME**

Publication Classification

(71) Applicant: **Samsung Electronics Co., Ltd.**, Suwon-si (KR)

(72) Inventors: **Seunghyun BAIK**, Seoul (KR); **Daewoo SUH**, Seoul (KR); **Dongmok LEE**, Suwon-si (KR); **Sanghoon LEE**, Suwon-si (KR)

(73) Assignee: **Research & Business Foundation Sungkyunkwan University**, Suwon-si (KR)

(21) Appl. No.: **14/724,220**

(22) Filed: **May 28, 2015**

(30) **Foreign Application Priority Data**

May 30, 2014 (KR) 10-2014-0066523

(51) **Int. Cl.**
A61B 5/00 (2006.01)
H01L 35/16 (2006.01)
H01L 35/18 (2006.01)
H02J 7/35 (2006.01)
H01L 35/20 (2006.01)
H01M 10/46 (2006.01)
A61B 5/11 (2006.01)
H01L 35/32 (2006.01)
H01L 35/22 (2006.01)

(52) **U.S. Cl.**
 CPC *A61B 5/6801* (2013.01); *H01L 35/32* (2013.01); *H01L 35/16* (2013.01); *H01L 35/18* (2013.01); *H01L 35/22* (2013.01); *H01L 35/20* (2013.01); *H01M 10/46* (2013.01); *A61B 5/1118* (2013.01); *H02J 7/355* (2013.01); *A61B 2560/0219* (2013.01)

(57) **ABSTRACT**

A thermoelectric material includes a stretchable polymer, and a thermoelectric structure and an electrically conductive material that are mixed together with the stretchable polymer. The thermoelectric material may be applied to self-power generating wearable electronic apparatuses.

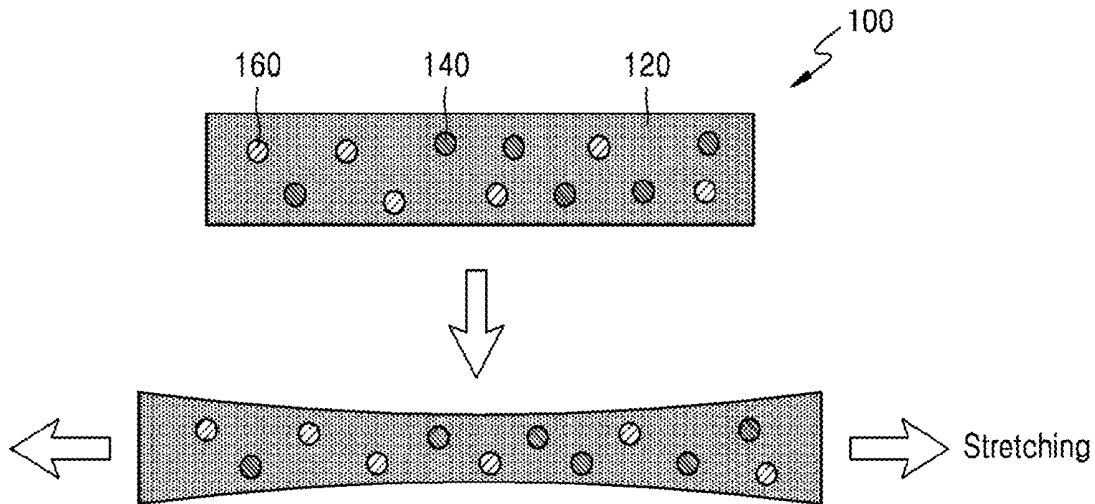

FIG. 1

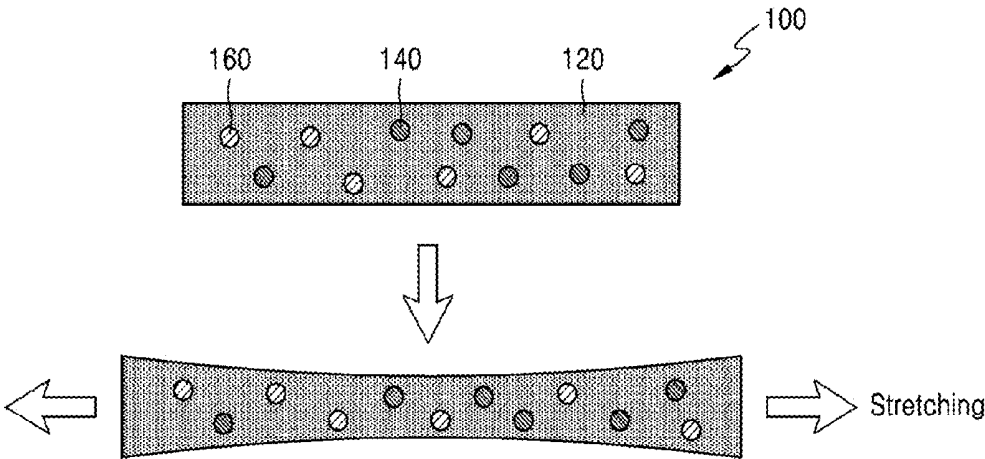

FIG. 2

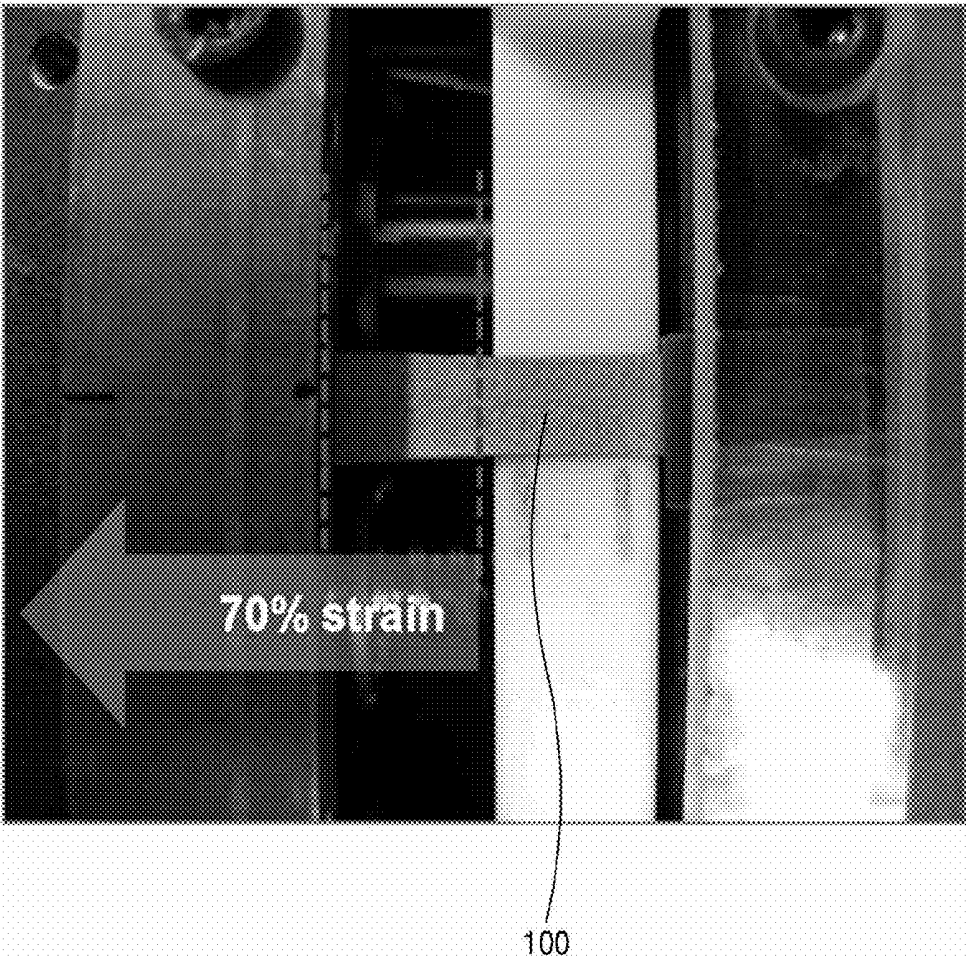

FIG. 3

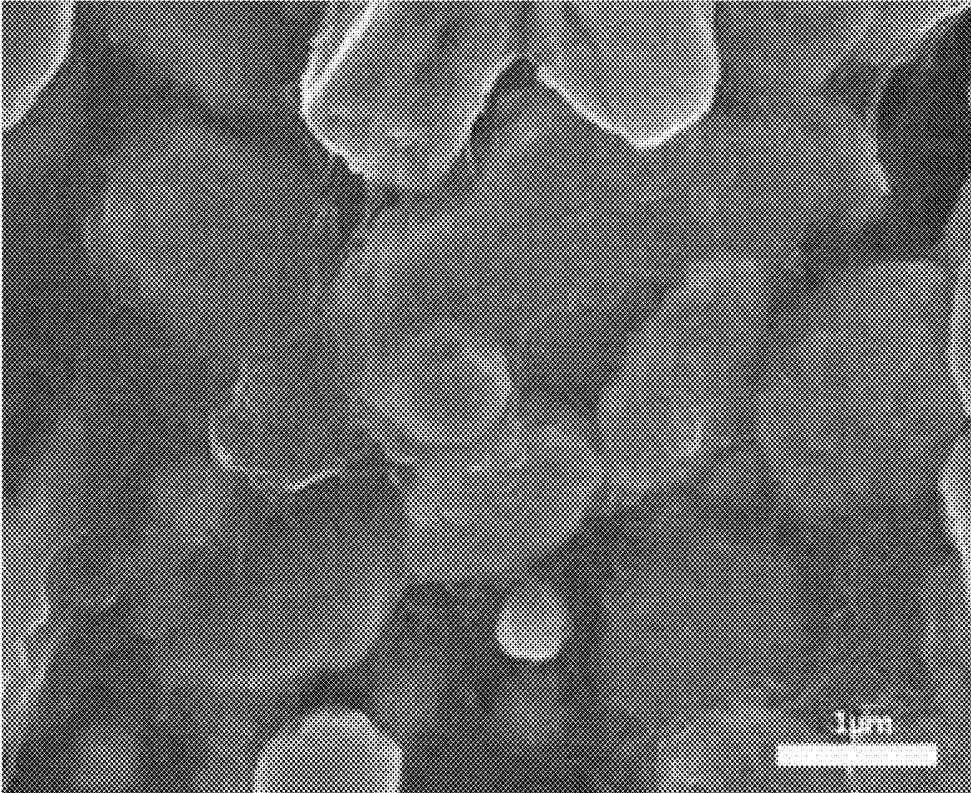

FIG. 4

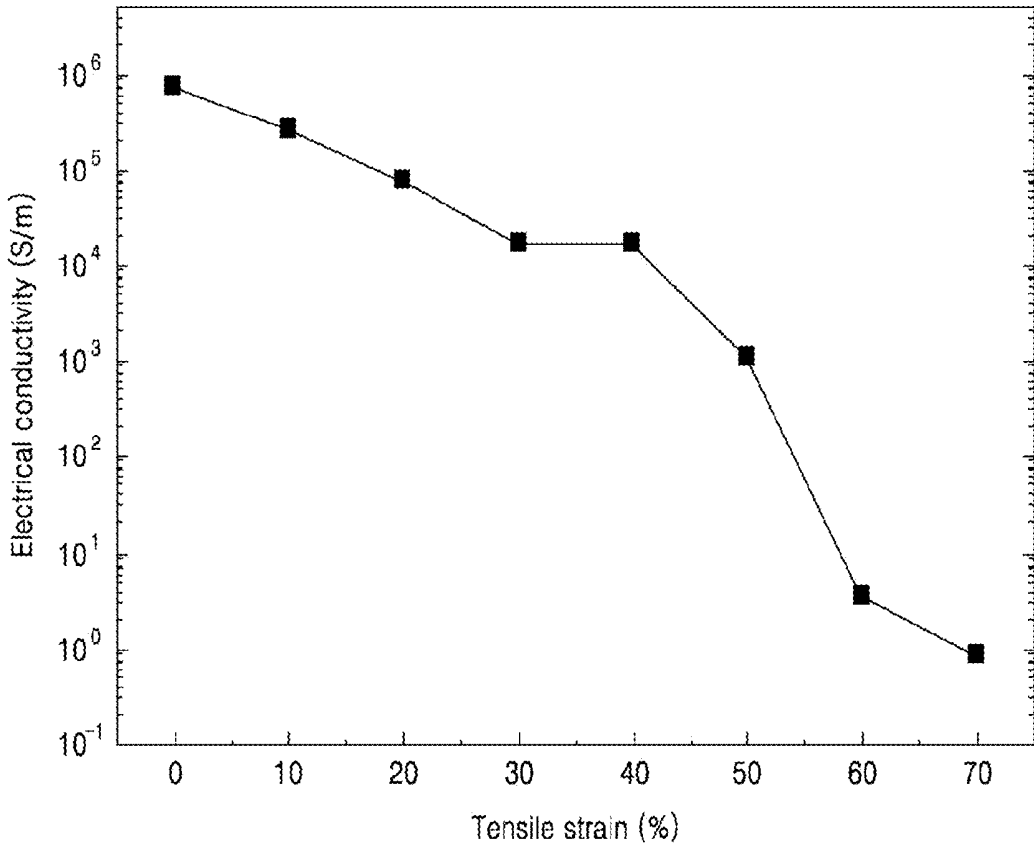

FIG. 5

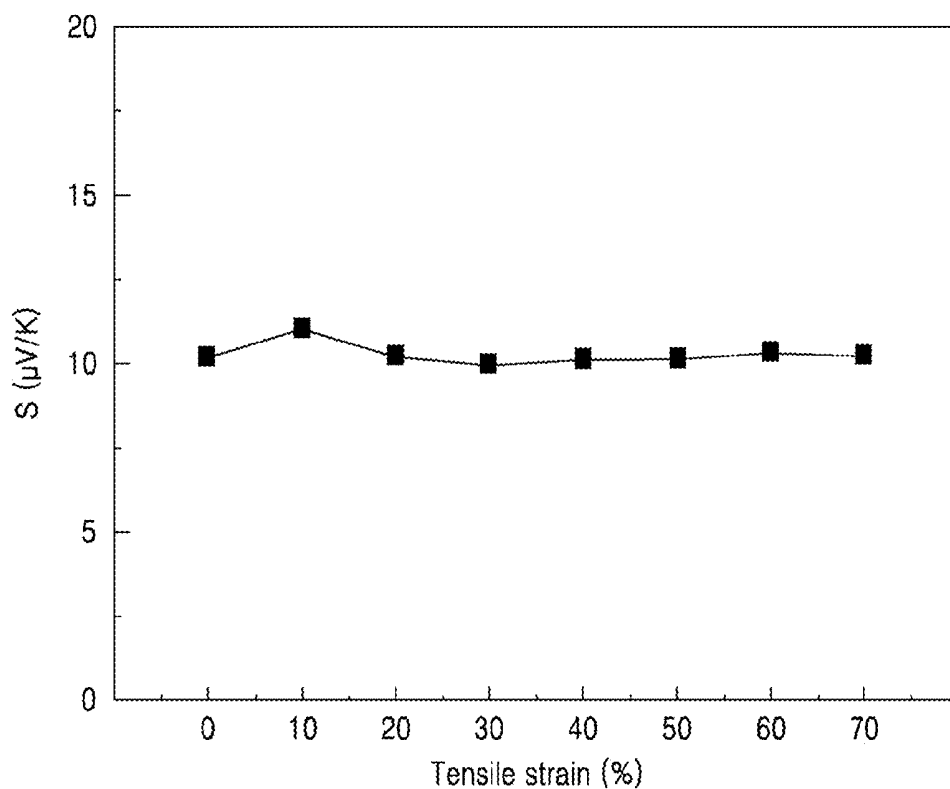

FIG. 6

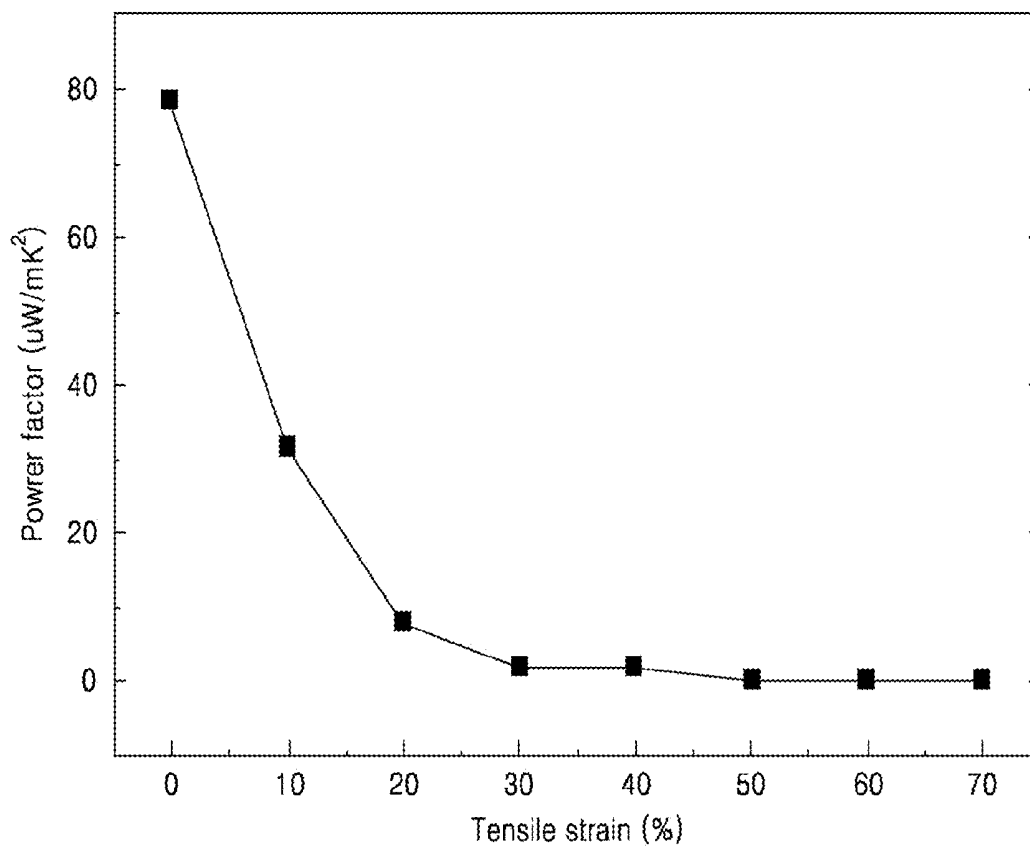

FIG. 7A

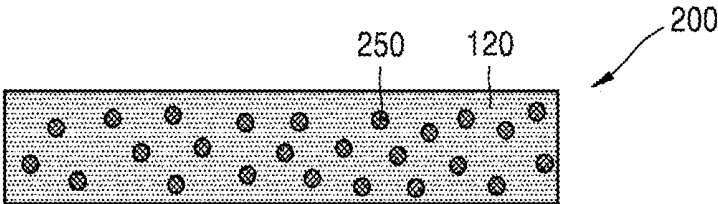

FIG. 7B

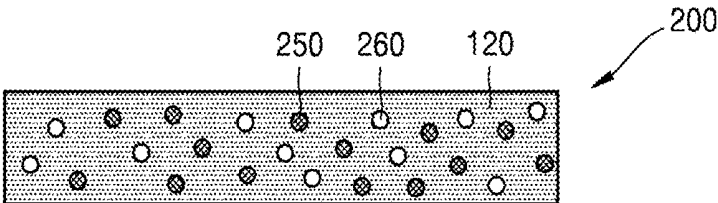

FIG. 8

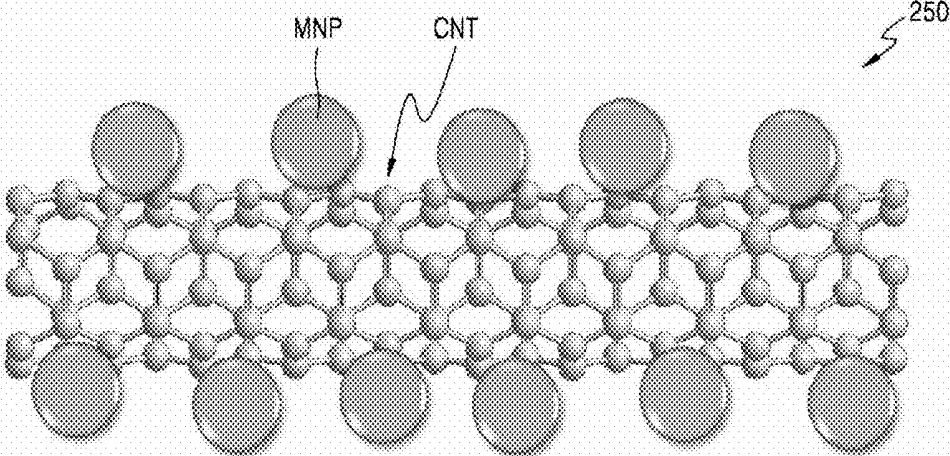

FIG. 9A

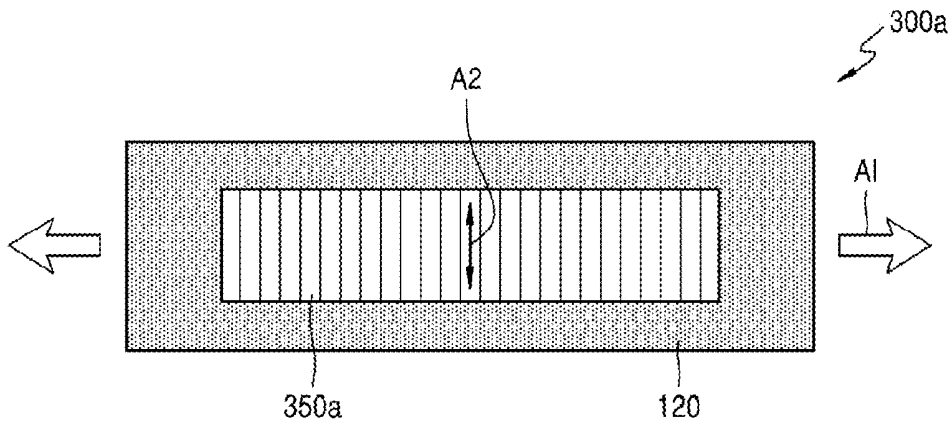

FIG. 9B

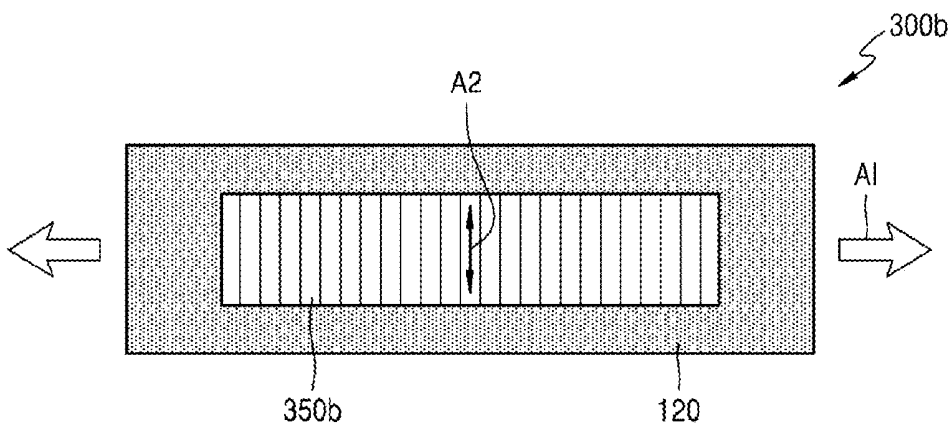

FIG. 9C

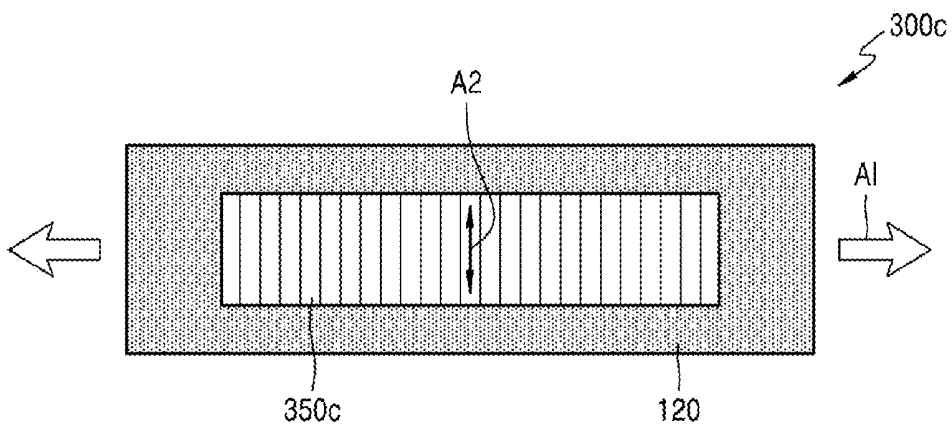

FIG. 10A

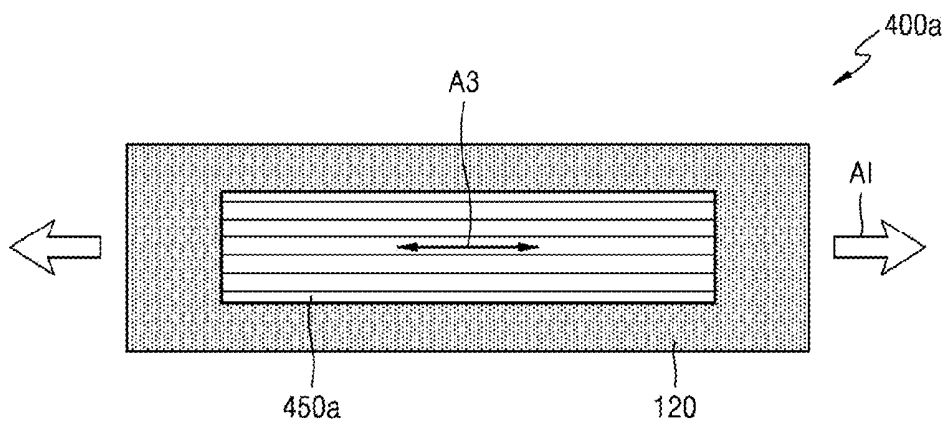

FIG. 10B

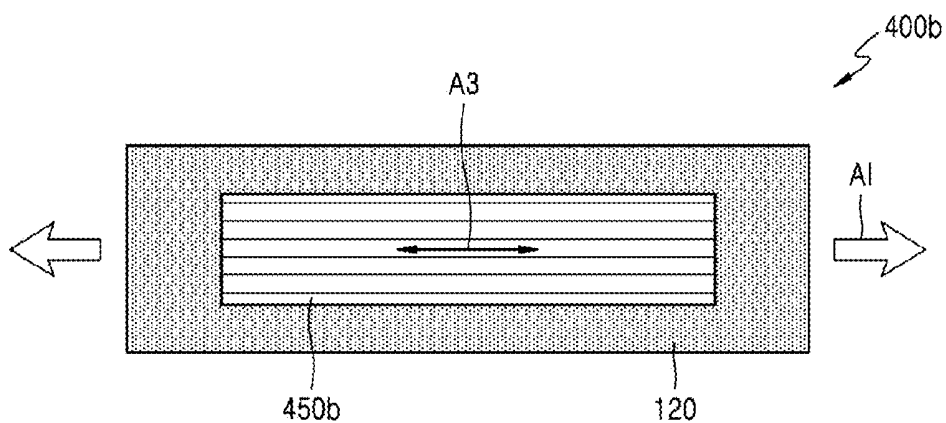

FIG. 10C

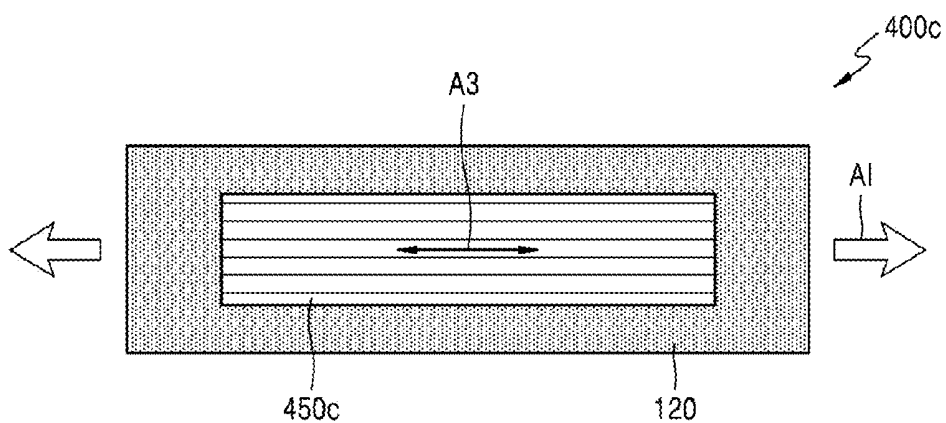

FIG. 11

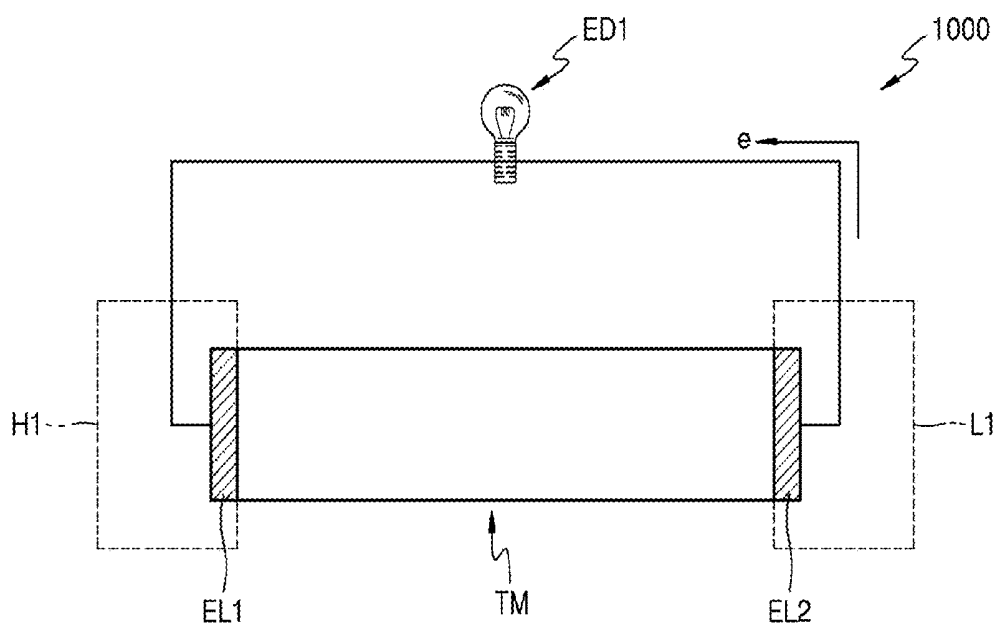

FIG. 12

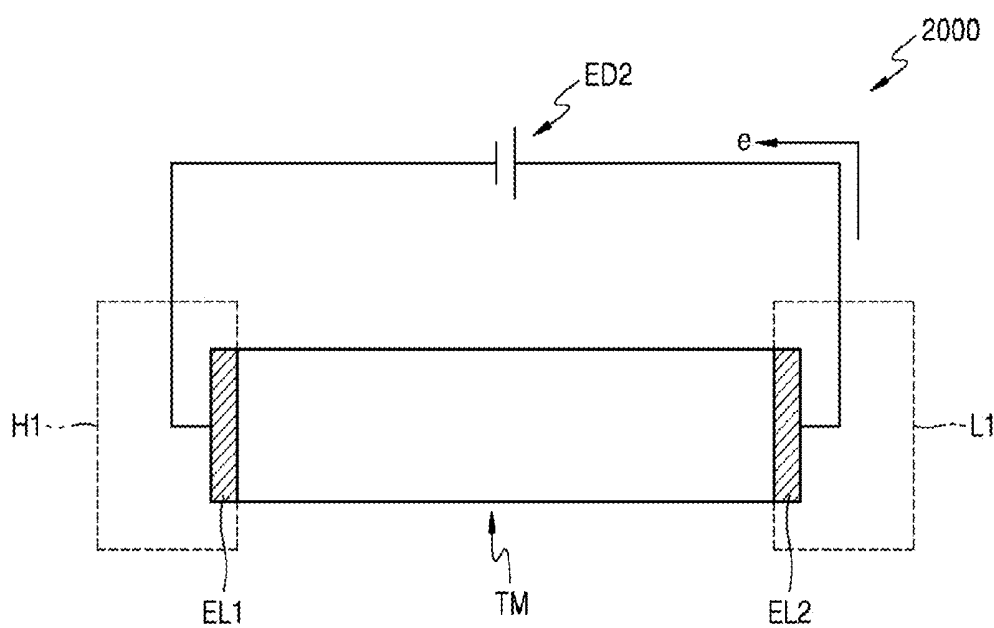

FIG. 13

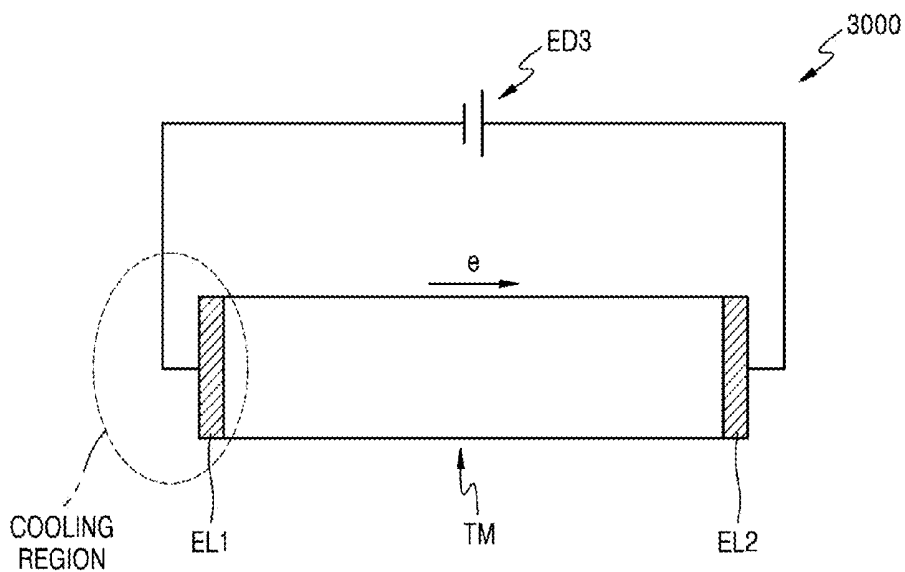
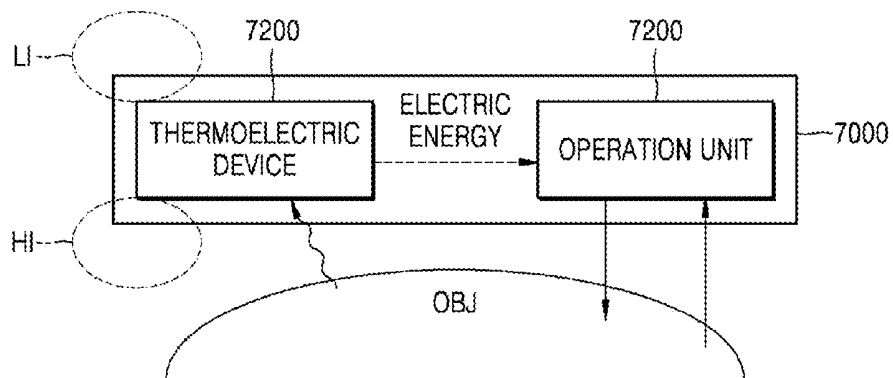

FIG. 14



**STRETCHABLE THERMOELECTRIC
MATERIAL AND THERMOELECTRIC
DEVICE INCLUDING THE SAME**

RELATED APPLICATION

[0001] This application claims priority under 35 U.S.C. §119 to Korean Patent Application No. 10-2014-0066523, filed on May 30, 2014, in the Korean Intellectual Property Office, the disclosure of which is incorporated herein in its entirety by reference.

BACKGROUND

[0002] 1. Field

[0003] The present disclosure relates to a stretchable thermoelectric material and/or a thermoelectric device including the stretchable thermoelectric material.

[0004] 2. Description of Related Art

[0005] Thermoelectric conversion is the conversion of thermal energy to electric energy and vice versa. The Peltier effect refers to an effect in which a temperature difference is generated between both ends of a thermoelectric material when a current flows through the thermoelectric material, and the Seebeck effect refers to an reverse effect in which electricity is generated when there is a temperature difference between both ends of a thermoelectric material.

[0006] Cooling systems operating by the Peltier effect may be effective to use in some applications where it may be difficult to use existing cooling systems such as passive cooling systems or refrigerant gas compression type cooling systems. Thermoelectric cooling is an eco-friendly cooling technique which does not use refrigerant gas, thereby limiting and/or preventing any environmental problems. If the efficiency of thermoelectric cooling is improved by the development of highly efficient thermoelectric cooling materials, the application field thereof may be expanded to general-purpose cooling apparatuses such as refrigerators and air conditioners.

[0007] In addition, the Seebeck effect may be used to produce electric energy from heat generated by computers, automobile engines, industrial plants, etc. Thermoelectric power generated by the Seebeck effect may become a new renewable energy source. Along with the increasing interest in new energy sources, the environment, the reuse of waste energy, etc., the interest in thermoelectric devices has increased.

[0008] There is an increasing interest in polymer thermoelectric materials or flexible thermoelectric materials for large-area thermoelectric devices or wearable thermoelectric apparatuses.

[0009] As compared with thermoelectric inorganic materials, polymer thermoelectric materials or flexible thermoelectric materials are non-toxic and inexpensive, and it is easy to manufacture large-area thermoelectric devices using polymer thermoelectric materials or flexible thermoelectric materials. In general, however, the thermoelectric conversion efficiency of polymer thermoelectric materials or flexible thermoelectric materials is low.

SUMMARY

[0010] Provided is a thermoelectric material having stretchability and high thermoelectric conversion efficiency.

[0011] Provided is a thermoelectric device including the thermoelectric material and applicable to wearable electronic apparatuses.

[0012] Additional aspects will be set forth in part in the description which follows and, in part, will be apparent from the description, or may be learned by practice of example embodiments.

[0013] According to example embodiments, a thermoelectric material includes a stretchable polymer, and a thermoelectric structure and an electrically conductive material that are mixed together with the stretchable polymer.

[0014] In example embodiments, the stretchable polymer may include at least one of poly(styrene-isoprene-styrene) (SIS), poly(styrene-butadiene-styrene) (SBS), poly(styrene-ethylene/butylene-styrene) (SEBS), polyvinylidene fluoride (PVDF), nitrile butadiene rubber (NBR), polyurethane (PU), poly(dimethylsiloxane) (PDMS), polyurethane acrylate (PUA), perfluoropolyether (PFPE), polyester (PE), polybutadiene (PB), and polyisoprene.

[0015] In example embodiments, the thermoelectric structure may include at least one of an Sb—Te-containing material, a Bi—Te-containing material, a Bi—Sb—Te-containing material, a Co—Sb-containing material, a Pb—Te-containing material, a Ge—Tb-containing material, a Si—Ge-containing material, a Sm—Co-containing material, and a carbon-containing material.

[0016] In example embodiments, the carbon-containing material may include at least one of carbon nanotubes, graphene, and graphite.

[0017] In example embodiments, the electrically conductive material may include at least one of a carbon nanomaterial and a metallic material.

[0018] In example embodiments, the carbon nanomaterial may include at least one of carbon nanotubes, graphene, and graphene nanoparticles.

[0019] In example embodiments, the electrically conductive material may include the carbon nanotubes and the metallic material. The metallic material may be metal nanoparticles. The metal nanoparticles may be adsorbed on surfaces of the carbon nanotubes.

[0020] In example embodiments, the metallic material may include gold (Au), silver (Ag), platinum (Pt), copper (Cu), nickel (Ni), aluminum (Al), palladium (Pd), rhodium (Rh), and ruthenium (Ru).

[0021] In example embodiments, the thermoelectric structure and the electrically conductive material mixed together may be carbon nanotubes and metal nanoparticles. The metal nanoparticles may be adsorbed on surfaces of the carbon nanotubes.

[0022] In example embodiments, the thermoelectric structure and the electrically conductive material may include carbon nanotubes.

[0023] In example embodiments, the carbon nanotubes may be a multi-walled carbon nanotube (MWCNT) array. The carbon nanotubes may be arranged in a direction.

[0024] In example embodiments, the multi-walled carbon nanotube array may be embedded in the stretchable polymer.

[0025] In example embodiments, the stretchable polymer may have uniaxial stretchability. A length of the carbon nanotubes in the multi-walled carbon nanotube array may be parallel to a stretching direction of the stretchable polymer.

[0026] In example embodiments, the stretchable polymer may have uniaxial stretchability. A length of the carbon nanotubes in the multi-walled carbon nanotube array may be perpendicular to a stretching direction of the stretchable polymer. According to example embodiments, a thermoelectric

device may include the thermoelectric material, and first and second electrodes electrically connected to respective ends of the thermoelectric material.

[0027] In example embodiments, the thermoelectric device may further include an electronic device electrically connected to the first and second electrodes.

[0028] In example embodiments, the electronic device may be one of a power consuming device, a power storage device, and a power supply device.

[0029] According to example embodiments, a wearable electronic apparatus may be configured to be put on an object for inspecting the object. The wearable electronic apparatus may include the thermoelectric material, first and second electrodes electrically connected to respective ends of the thermoelectric material, a power storage device connected to the first and second electrodes, and an operation unit. The power storage device may be configured to store electric energy generated in the thermoelectric material based on a temperature difference between both the ends of the thermoelectric material. The temperature difference may be caused by heat provided by the object. The operation unit may be configured to receive the electric energy from the power storage device and to perform an inspection operation on the object.

[0030] In example embodiments, the operation unit may be configured to measure a health or motion status of the object.

[0031] According to example embodiments, an electronic apparatus includes the thermoelectric material, first and second electrodes electrically connected to respective ends of the thermoelectric material, and a power supply device connected to the first and second electrodes. The power supply device is configured to apply a current to the thermoelectric material for forming a hot spot cooling region at one of the respective ends of the thermoelectric material.

[0032] According to example embodiments, a thermoelectric material includes a stretchable polymer, a thermoelectric structure mixed in the stretchable polymer, and an electrically conductive material mixed in the stretchable polymer. The thermoelectric material contains carbon.

[0033] In example embodiments, the stretchable polymer may include at least one of poly(styrene-isoprene-styrene) (SIS), poly(styrene-butadiene-styrene) (SBS), poly(styrene-ethylene/butylene-styrene) (SEBS), poly(vinylidene fluoride) (PVDF), nitrile butadiene rubber (NBR), polyurethane (PU), poly(dimethylsiloxane) (PDMS), polyurethane acrylate (PUA), perfluoropolyether (PFPE), polyester (PE), polybutadiene (PB), and polyisoprene.

[0034] In example embodiments, the electrically conductive material may include metal nanoparticles.

[0035] In example embodiments, the thermoelectric structure may include carbon nanotubes embedded in the stretchable polymer. The metal nanoparticles may be adsorbed on the carbon nanotubes.

[0036] In example embodiments, the carbon nanotubes may be arranged in an array and lengths of the carbon nanotubes may be parallel to each other.

BRIEF DESCRIPTION OF THE DRAWINGS

[0037] The foregoing and other features of inventive concepts will be apparent from the more particular description of non-limiting embodiments of inventive concepts, as illustrated in the accompanying drawings in which like reference characters refer to like parts throughout the different views.

The drawings are not necessarily to scale, emphasis instead being placed upon illustrating principles of inventive concepts. In the drawings:

[0038] FIG. 1 is a schematic view illustrating a thermoelectric material according to example embodiments;

[0039] FIG. 2 is an image illustrating a stretched state of a thermoelectric material sample prepared according to example embodiments;

[0040] FIG. 3 is a scanning electron microscope (SEM) image taken from a surface of the thermoelectric material sample on an enlarged scale;

[0041] FIG. 4 is a graph illustrating a relationship between electrical conductivity and tensile strain of a thermoelectric material according to example embodiments;

[0042] FIG. 5 is a graph illustrating a relationship between a Seebeck coefficient and tensile strain of a thermoelectric material according to example embodiments;

[0043] FIG. 6 is a graph illustrating a relationship between a power factor and tensile strain of a thermoelectric material according to example embodiments;

[0044] FIG. 7A is a schematic view illustrating a thermoelectric material according to example embodiments;

[0045] FIG. 7B is a schematic view illustrating a thermoelectric material according to example embodiments;

[0046] FIG. 8 is a detailed view illustrating a nanostructure included in the thermoelectric material of FIG. 7A;

[0047] FIGS. 9A to 9C are schematic views illustrating thermoelectric materials according to example embodiments;

[0048] FIGS. 10A to 10C are schematic views illustrating thermoelectric materials according to example embodiments;

[0049] FIG. 11 is a schematic view illustrating a thermoelectric device according to example embodiments;

[0050] FIG. 12 is a schematic view illustrating a thermoelectric device according to example embodiments;

[0051] FIG. 13 is a schematic view illustrating a thermoelectric device according to example embodiments; and

[0052] FIG. 14 is a schematic block diagram of a wearable electronic apparatus according to example embodiments.

DETAILED DESCRIPTION

[0053] Example embodiments will now be described more fully with reference to the accompanying drawings, in which some example embodiments are shown. Example embodiments, may, however, be embodied in many different forms and should not be construed as being limited to the embodiments set forth herein; rather, these example embodiments are provided so that this disclosure will be thorough and complete, and will fully convey the scope of example embodiments of inventive concepts to those of ordinary skill in the art. In the drawings, the thicknesses of layers and regions are exaggerated for clarity. Like reference characters and/or numerals in the drawings denote like elements, and thus their description may be omitted.

[0054] It will be understood that when an element is referred to as being “connected” or “coupled” to another element, it can be directly connected or coupled to the other element or intervening elements may be present. In contrast, when an element is referred to as being “directly connected” or “directly coupled” to another element, there are no intervening elements present. Other words used to describe the relationship between elements or layers should be interpreted in a like fashion (e.g., “between” versus “directly between,” “adjacent” versus “directly adjacent,” “on” versus “directly

on”). As used herein the term “and/or” includes any and all combinations of one or more of the associated listed items.

[0055] It will be understood that, although the terms “first”, “second”, etc. may be used herein to describe various elements, components, regions, layers and/or sections. These elements, components, regions, layers and/or sections should not be limited by these terms. These terms are only used to distinguish one element, component, region, layer or section from another element, component, region, layer or section. Thus, a first element, component, region, layer or section discussed below could be termed a second element, component, region, layer or section without departing from the teachings of example embodiments.

[0056] Spatially relative terms, such as “beneath,” “below,” “lower,” “above,” “upper” and the like, may be used herein for ease of description to describe one element or feature’s relationship to another element(s) or feature(s) as illustrated in the figures. It will be understood that the spatially relative terms are intended to encompass different orientations of the device in use or operation in addition to the orientation depicted in the figures. For example, if the device in the figures is turned over, elements described as “below” or “beneath” other elements or features would then be oriented “above” the other elements or features. Thus, the term “below” can encompass both an orientation of above and below. The device may be otherwise oriented (rotated 90 degrees or at other orientations) and the spatially relative descriptors used herein interpreted accordingly.

[0057] The terminology used herein is for the purpose of describing particular embodiments only and is not intended to be limiting of example embodiments. As used herein, the singular forms “a,” “an” and “the” are intended to include the plural forms as well, unless the context clearly indicates otherwise. It will be further understood that the terms “comprises”, “comprising”, “includes” and/or “including,” if used herein, specify the presence of stated features, integers, steps, operations, elements and/or components, but do not preclude the presence or addition of one or more other features, integers, steps, operations, elements, components and/or groups thereof. Expressions such as “at least one of,” when preceding a list of elements, modify the entire list of elements and do not modify the individual elements of the list.

[0058] Example embodiments are described herein with reference to cross-sectional illustrations that are schematic illustrations of idealized embodiments (and intermediate structures) of example embodiments. As such, variations from the shapes of the illustrations as a result, for example, of manufacturing techniques and/or tolerances, are to be expected. Thus, example embodiments should not be construed as limited to the particular shapes of regions illustrated herein but are to include deviations in shapes that result, for example, from manufacturing. Thus, the regions illustrated in the figures are schematic in nature and their shapes are not intended to illustrate the actual shape of a region of a device and are not intended to limit the scope of example embodiments.

[0059] Unless otherwise defined, all terms (including technical and scientific terms) used herein have the same meaning as commonly understood by one of ordinary skill in the art to which example embodiments belong. It will be further understood that terms, such as those defined in commonly-used dictionaries, should be interpreted as having a meaning that is consistent with their meaning in the context of the relevant art

and will not be interpreted in an idealized or overly formal sense unless expressly so defined herein.

[0060] FIG. 1 is a schematic view illustrating a thermoelectric material **100** according to example embodiments.

[0061] In example embodiments, the thermoelectric material **100** may have high thermoelectric conversion efficiency and stretchability.

[0062] In general, the thermoelectric figure of merit (zT) of a thermoelectric material is defined by Equation 1 below:

$$zT = (\alpha^2 \sigma T) / \kappa \quad (1)$$

wherein α denotes a Seebeck coefficient, σ denotes electric conductivity, T denotes absolute temperature, and κ denotes thermal conductivity.

[0063] In Equation 1, $\alpha^2 \sigma$ is called a power factor.

[0064] Referring to Equation 1, the thermoelectric figure of merit (zT) of a thermoelectric material may be increased by increasing the Seebeck coefficient and the electric conductivity of the thermoelectric material and decreasing the thermal conductivity of the thermoelectric material.

[0065] As a result of effort to obtain a thermoelectric material having high thermoelectric conversion efficiency and stretchability based on the above-described relation, the thermoelectric material **100** according to example embodiments may be formed by mixing a thermoelectric structure **140** and an electrically conductive material **160** together with a stretchable polymer **120**.

[0066] The stretchable polymer **120** may be any kind of stretchable polymer. For example, the stretchable polymer **120** may be at least one of poly(styrene-isoprene-styrene) (SIS), poly(styrene-butadiene-styrene) (SBS), poly(styrene-ethylene/butylene-styrene) (SEBS), polyvinylidene fluoride (PVDF), nitrile butadiene rubber (NBR), polyurethane (PU), poly(dimethylsiloxane) (PDMS), polyurethane acrylate (PUA), perfluoropolyether (PFPE), polyester (PE), polybutadiene (PB), polyisoprene, and a combination thereof.

[0067] The thermoelectric structure **140** may be an Sb—Te-containing thermoelectric inorganic material, a Bi—Te-containing thermoelectric inorganic material, a Bi—Sb—Te-containing thermoelectric inorganic material, a Co—Sb-containing thermoelectric inorganic material, a Pb—Te-containing thermoelectric inorganic material, a Ge—Tb-containing thermoelectric inorganic material, a Si—Ge-containing thermoelectric inorganic material, a Sm—Co-containing thermoelectric inorganic material, or a carbon-containing thermoelectric material.

[0068] Examples of the Sb—Te-containing thermoelectric inorganic material may include Sb_2Te_3 , $AgSbTe_2$, and $CuSbTe_2$, and examples of the Bi—Te-containing thermoelectric inorganic material may include Bi_2Te_3 , and a thermoelectric inorganic material containing $(Bi,Sb)_2(Te,Se)_3$. Examples of the Co—Sb-containing thermoelectric inorganic material may include $CoSb_3$, and examples of the Pb—Te-containing thermoelectric inorganic material may include $PbTe$ and $(PbTe)_mAgSbTe_2$. In addition, any other inorganic material used in the thermoelectric field may be used as the thermoelectric inorganic material **140**.

[0069] Examples of the carbon-containing material may include carbon nanotubes, graphene, and graphite. In detail, examples of the carbon-containing material may include single walled carbon nanotubes, double walled carbon nanotubes (CNTs), multi-walled carbon nanotubes (MWCNTs), rope carbon nanotubes, graphene oxides, graphene nanorib-

bons, carbon black, and carbon nanofibers. However, the carbon-containing material is not limited thereto.

[0070] The electrically conductive material **160** may be a metallic material or a carbon nanomaterial. Examples of the metallic material may include gold (Au), silver (Ag), platinum (Pt), copper (Cu), nickel (Ni), aluminum (Al), palladium (Pd), rhodium (Rh), and ruthenium (Ru), and examples of the carbon nanomaterial may include carbon nanotubes, graphene, and graphene nanoparticles.

[0071] The thermoelectric material **100** may be manufactured by various mixing methods.

[0072] For example, the thermoelectric structure **140** and the electrically conductive material **160** may be prepared in the form of powder or flakes and may be dispersed into a solution of the stretchable polymer **120**. Thereafter, a solvent may be evaporated from the solution to form the thermoelectric material **100**. The solvent may be water or any one selected from various organic solvents. The solvent may be evaporated naturally or by heat.

[0073] Alternatively, the thermoelectric material **100** may be manufactured by preparing powder of the stretchable polymer **120**, the thermoelectric structure **140**, and the electrically conductive material **160**, mixing the powder with a solvent, and evaporating the solvent.

[0074] Alternatively, a dry mixing method may be used. That is, particles of the stretchable polymer **120**, the thermoelectric structure **140**, and the electrically conductive material **160** may be mixed together by using a general mixer, and the mixture may be compressed to form the thermoelectric material **100**.

[0075] FIG. 2 is an image illustrating a stretched state of a sample of the thermoelectric material **100**, and FIG. 3 is a scanning electron microscope (SEM) image taken from a surface of the sample on an enlarged scale.

[0076] The sample was made by mixing silver (Ag) flakes, carbon nanotubes, and poly(styrene-isoprene-styrene) (SIS), and was stretched by about 70% in a tension test as shown in FIG. 2.

[0077] A brief description will now be given of how the sample was made. However, the method described below is a non-limiting example.

[0078] First, 2 g of poly(styrene-isoprene-styrene) (SIS) polymer was put into 50 ml of toluene solution and was agitated for about 1 hour while heating the solution at 60° C. to prepare a dispersion solution.

[0079] Next, 0.8 g of silver (Ag) flakes and 0.1 g of carbon nanotubes were added to the dispersion solution as an electrically conductive material and a thermoelectric structure, and were mixed for 10 minutes by using a tip sonicator at the power of 700 W.

[0080] Thereafter, a dispersion medium was naturally dried at room temperature. In this way, the sample was made in the form of a film.

[0081] FIGS. 4 to 6 are graphs illustrating the electric conductivity, Seebeck coefficient, and power factor of the thermoelectric material **100** with respect to tensile strain of the thermoelectric material **100** according to example embodiments.

[0082] Referring to FIG. 4, the electric conductivity of the thermoelectric material **100** reduces as the tensile strain of the thermoelectric material **100** increases, and the electric conductivity starts to reduce steeply when the tensile strain is about 50% or greater.

[0083] Referring to FIG. 5, the Seebeck coefficient of the thermoelectric material **100** is almost constant with respect to the tensile strain of the thermoelectric material **100**.

[0084] Referring to FIG. 6, the power factor of the thermoelectric material **100** reduces as the tensile strain of the thermoelectric material **100** increases. However, the power factor reduces very little and remains almost constant when the tensile strain is about 20% or greater.

[0085] The power factor is $\alpha^2\sigma$ in Equation 1 described above to introduce the thermoelectric figure of merit (zT).

[0086] The above-described experimental results may prove that the thermoelectric material **100** could be manufactured to have desired stretchability and thermoelectric efficiency by properly combining components of the thermoelectric material **100**.

[0087] Hereinafter, thermoelectric materials according to example embodiments will be described.

[0088] FIG. 7A is a schematic view illustrating a thermoelectric material **200** according to example embodiments. FIG. 7A is a schematic view illustrating a thermoelectric material **200** according to example embodiments. FIG. 8 is a detailed view illustrating a nanostructure **250** included in the thermoelectric material **200** illustrated in FIG. 7A.

[0089] In example embodiments, as shown in FIG. 7A, the thermoelectric material **200** may be made by mixing a stretchable polymer **120** with nanostructures **250** having conductivity and thermoelectric characteristics.

[0090] Referring to FIG. 8, each of the nanostructures **250** includes a carbon nanotube CNT and metal nanoparticles MNP adsorbed on the surface of the carbon nanotube.

[0091] The carbon nanotubes CNT have thermoelectric characteristics and conductivity, and since the metal nanoparticles MNP are adsorbed on the surfaces of the carbon nanotubes CNT, the nanostructures **250** may have thermoelectric characteristics and high conductivity. Since the thermoelectric material **200** is made by dispersing the nanostructures **250** into the stretchable polymer **120**, the thermoelectric material **200** has stretchability.

[0092] The nanostructures **250** may be used as the thermoelectric structure **140** of the thermoelectric material **100** illustrated in FIG. 1. That is, the thermoelectric material **100** may be made by mixing the nanostructures **250** and the electrically conductive material **160** with the stretchable polymer **120**. In addition, as shown in FIG. 7B, a thermoelectric material **200'** according to example embodiments may further include electrically conductive material **260** that is spaced apart from the nanostructures **250**. The electrically conductive material **260** may be particles. The electrically conductive material **260** may be a metallic material or a carbon nanomaterial. Examples of the metallic material may include gold (Au), silver (Ag), platinum (Pt), copper (Cu), nickel (Ni), aluminum (Al), palladium (Pd), rhodium (Rh), and ruthenium (Ru), and examples of the carbon nanomaterial may include carbon nanotubes, graphene, and graphene nanoparticles. The electrically conductive material **260** may be a different material than the metallic nanoparticle MNP included in the nanostructures **250**.

[0093] Hereinafter, explanations will be given of the electrical conductivity values, Seebeck coefficients, and power factors of thermoelectric material samples made while varying constitutional components of the samples and contents of the components.

[0094] Table 1 below shows thermoelectric properties of samples having different contents of thermoelectric structures and electrically conductive materials.

TABLE 1

SAM- PLE #	COMPOSITION	ELECTRICAL CONDUCT- TIVITY (S/M)	SEEBECK COEFFICIENT (MV/K)	POWER FACTOR (MW/ MK ²)
1	Ag flakes (0.8 g) + CNTs (0.1 g) + SIS polymer (2 g)	2.449×10^5	10.7	28.04
2	Ag flakes (0.4 g) + Sb ₂ Te ₃ (0.4 g) + CNTs (0.1 g) + SIS polymer (2 g)	3.398×10^2	27.2	0.25
3	Sb ₂ Te ₃ (0.4 g) + CNTs (0.1 g) + SIS polymer (2 g)	1.458×10^2	37.2	0.20

[0095] The samples were made by using SIS polymer as a stretchable polymer, CNTs and/or Sb₂Te₃ as thermoelectric structures, and silver (Ag) and/or CNTs as electrically conductive materials. That is, CNTs were used as a material having electric conductivity and thermoelectric characteristics. While maintaining the content of the stretchable polymer at a constant value, the contents of the thermoelectric structures and the electrically conductive materials were varied. As a result, the electrical conductivity values of the samples were markedly varied according to the use or content of silver (Ag), and it was analyzed that the power factors of the samples were mainly affected by the use or content of silver (Ag).

[0096] Table 2 below shows thermoelectric properties of samples having different contents of thermoelectric structures and electrically conductive materials and the same contents of silver (Ag) flakes and SIS polymer.

TABLE 2

SAM- PLE #	COMPOSITION	ELECTRICAL CONDUCT- TIVITY (S/M)	SEEBECK COEFFICIENT (MV/K)	POWER FACTOR (MW/MK ²)
4	Ag flakes (0.8 g) + CNTs (0.1 g) + SIS polymer (2 g)	2.449×10^5	10.7	28.04
5	Ag flakes (0.8 g) + CNTs (0.05 g) + SIS polymer (2 g)	5.695×10^5	8.94	45.52
6	Ag flake (0.8 g) + CNTs (0.025 g) + SIS polymer (2 g)	7.474×10^5	10.1	76.24
7	Ag flakes (0.8 g) + Ag/CNTs (0.1 g) + SIS polymer (2 g)	1.850×10^5	10.3	19.63

[0097] The samples were made by using SIS polymer as a stretchable polymer, CNTs as a thermoelectric structure, and silver (Ag) and CNTs as electrically conductive materials. Ag/CNTs of Sample 7 refers to nanostructures in which silver (Ag) nanoparticles are adsorbed on surfaces of CNTs, like the nanostructures 250 of thermoelectric material 200 according to example embodiments that is explained with reference to FIG. 7A. Referring to Table 2, if the content of CNTs is low, the Seebeck coefficient is low but the electric conductivity is high due to a relatively high content of silver (Ag). As a result, the power factor is high.

[0098] FIGS. 9A to 9C are schematic views illustrating thermoelectric materials 300a to 300c according to example embodiments.

[0099] Referring to FIG. 9A, the thermoelectric material 300a includes carbon nanotubes having thermoelectric characteristics and electric conductivity. In detail, the thermoelectric material 300a includes a stretchable polymer 120 and a multi-walled carbon nanotube array 350a.

[0100] In the multi-walled carbon nanotube array 350a, carbon nanotubes may be arranged in one direction. That is, lengths of a plurality of nanotubes constituting the multi-walled carbon nanotube array 350a may be parallel to each other. The multi-walled carbon nanotube array 350a may be embedded in the stretchable polymer 120. The stretchable polymer 120 may have uniaxial stretchability as indicated by an arrow A1. In other words, a stretching direction of the stretchable polymer 120 may be indicated by the arrow A1. A length direction A2 of the carbon nanotubes of the multi-walled carbon nanotube array 350a and a stretchable direction A1 of the stretchable polymer 120 may be perpendicular to each other.

[0101] Referring to FIG. 9B, the thermoelectric material 300b includes carbon nanostructures having thermoelectric characteristics and electric conductivity. In detail, the thermoelectric material 300b includes a stretchable polymer 120 and a nanostructure array 350b. The nanostructures in the nanostructure array 350b may include multi-walled carbon nanotubes with metal nanoparticles adsorbed on the surfaces of the carbon nanotubes (e.g., multi-walled carbon nanotubes), such as a plurality of the nanostructures 250 described previously with reference to FIG. 8.

[0102] In the nanostructure array 350b, the carbon nanotubes of the nanostructures in the nanostructure array 350b may be arranged in one direction. That is, lengths of nanotubes in the nanostructures constituting the nanostructure array 350b may be parallel to each other. The nanostructure array 350b may be embedded in the stretchable polymer 120. The stretchable polymer 120 may have uniaxial stretchability as indicated by an arrow A1. A length direction A2 of the carbon nanotubes in the nanostructures of the nanostructure array 350b and a stretchable direction A1 of the stretchable polymer 120 may be perpendicular to each other.

[0103] Referring to FIG. 9C, the thermoelectric material 300c may be the same as the thermoelectric material 300b described in FIG. 9B, except the nanostructure array 350c further includes additional electrically conductive material dispersed in the stretchable polymer 120 and separate from the nanostructure array 350c, similar to the electrically conductive material 260 described in FIG. 7B.

[0104] Although examples are described with reference to FIGS. 9A to 9C where the carbon nanotube arrays 350a to 350c may include multi-walled carbon nanotubes, example embodiments are not limited thereto. For example, single-walled carbon nanotubes or a different carbon-containing structure (e.g., rope carbon nanotubes) may be used instead of multi-walled carbon nanotubes.

[0105] FIGS. 10A to 10C are schematic views illustrating thermoelectric materials 400a, 400b, and 400c according to example embodiments.

[0106] Referring to FIG. 10A, the thermoelectric material 400a may have a structure that is similar to the thermoelectric material 300a of FIG. 9A, except for an arrangement of the carbon nanotubes in the multi-walled carbon nanotube array 450a compared to the carbon nanotubes in the multi-walled

carbon nanotube array **350a**. That is, in the thermoelectric material **400a**, a multi-walled carbon nanotube array **450a** in which carbon nanotubes are arranged in one direction is embedded in a stretchable polymer **120** having uniaxial stretchability (**A1**). In the thermoelectric material **400a**, a length direction **A3** of the multi-walled carbon nanotube array **450a** may be parallel to a stretchable direction **A1**. In other words, a length direction **A3** of the carbon nanotubes in the multi-walled carbon nanotube array **450a** may be parallel to a stretching direction of the stretchable polymer **120**.

[0107] Referring to FIG. 10B, the thermoelectric material **400b** may have a structure that is similar to the thermoelectric material **300b** of FIG. 9B, except for an arrangement of the carbon nanotubes in the nanostructure array **450b** compared the carbon nanotubes in the nanostructure array **350b**. That is, in the thermoelectric material **400b**, a nanostructure array **450b** in which carbon nanotubes are arranged in one direction is embedded in a stretchable polymer **120** having uniaxial stretchability (**A1**). In the thermoelectric material **400b**, a length direction **A3** of the carbon nanotubes in the nanostructure array **450b** may be parallel to a stretchable direction **A1**. In other words, a length direction **A3** of the carbon nanotubes in the nanostructure array **450b** may be parallel to a stretching direction of the stretchable polymer **120**.

[0108] Referring to FIG. 10C, the thermoelectric material **400c** may have a structure that is the same as the thermoelectric material **400b** in FIG. 10B, except that the nanostructure array **450c** further includes additional electrically conductive material dispersed in the stretchable polymer and separate from the nanostructure array **450c**, similar to the electrically conductive material **260** described in FIG. 7B.

[0109] The above-described thermoelectric materials **100**, **200**, **200'**, **300a**, **300b**, **300c**, **400a**, **400b**, and **400c** may further include electrode structures to provide a current for inducing thermoelectric conversion therein or to use or collect electricity generated by thermoelectric conversion therein. Each of the electrode structures may include two electrodes disposed on and electrically connected to both ends of each of the thermoelectric materials **100**, **200**, **200'**, **300a**, **300b**, **300c**, **400a**, **400b**, and **400c**. The thermoelectric materials **100**, **200**, **200'**, **300a**, **300b**, **300c**, **400a**, **400b**, and **400c**, and electronic devices such as power consuming devices, power storage devices, or power supply devices connected to the electrodes may be used as thermoelectric devices having various functions.

[0110] FIG. 11 is a schematic view illustrating a thermoelectric device **1000** according to example embodiments.

[0111] The thermoelectric device **1000** includes a thermoelectric material **TM**, first and second electrodes **EL1** and **EL2** formed at respective both ends of the thermoelectric material **TM**, and a power consuming device **ED1** disposed between the first and second electrodes **EL1** and **EL2**.

[0112] An end of the thermoelectric material **TM** (for example, where the first electrode **EL1** is formed) may be in contact with a relatively high temperature region **H1**, and the other end of the thermoelectric material **TM** (for example, where the second electrode **EL2** is formed) may be in contact with a relatively low temperature region **L1**. In this case, electricity may be generated in the thermoelectric material **TM** by the thermoelectric effect. For example, electrons e^- (or holes) may move from the end of the thermoelectric material **TM** making contact with the high temperature region **H1** to the other end of the thermoelectric material making contact with the low temperature region **L1**. The electrons e^- (or

holes) may flow through the power consuming device **ED1**. In this way, electricity generated by the thermoelectric material **TM** may be consumed by the power consuming device **ED1**.

[0113] A bulb is shown as the power consuming device **ED1**. However, the bulb is a non-limited example. That is, various kinds of loads consuming electricity generated by the thermoelectric material **TM** may be used.

[0114] The thermoelectric material **TM** may be any one of the above-described thermoelectric materials **100**, **200**, **200'**, **300a**, **300b**, **300c**, **400a**, **400b**, and **400c** or may be a combination thereof. Since the thermoelectric material **TM** has stretchability and improved thermoelectric characteristics, the thermoelectric device **1000** may have high thermoelectric conversion efficiency.

[0115] FIG. 12 is a schematic view illustrating a thermoelectric device **2000** according to example embodiments.

[0116] The thermoelectric device **2000** is different from the thermoelectric device **1000** of FIG. 11, in that an electronic device connected to both ends of the thermoelectric device **2000** is a power storage device **ED2**. For example, the power storage device **ED2** may be a storage battery configured to store electricity generated by a thermoelectric material **TM** of the thermoelectric device **2000**.

[0117] FIG. 13 is a schematic view illustrating a thermoelectric device **3000** according to example embodiments.

[0118] The thermoelectric device **3000** may be a thermoelectric cooling device.

[0119] Referring to FIG. 13, first and second electrodes **EL1** and **EL2** may be provided on both ends of a thermoelectric material **TM**, and a power supply device **ED3** may be connected between the first and second electrodes **EL1** and **EL2**. If a current is supplied from the power supply device **ED3** to the thermoelectric material **TM**, an end of the thermoelectric material **TM** may absorb heat from surrounding objects by the Peltier effect. That is, heat may be absorbed at an end of the thermoelectric material **TM**. Therefore, the surrounding area of the end of the thermoelectric material **TM** may be cooled. The structure of the power supply device **ED3** may be variously changed.

[0120] The thermoelectric device **3000** may be used for various electronic apparatuses requiring hot spot cooling. For example, the thermoelectric device **3000** may be applied to portable electronic apparatuses such as smartphones, tablet personal computers (PCs), or micro packages, or may be applied to wearable small electronic apparatuses.

[0121] Each of the thermoelectric materials **TM** of the thermoelectric devices **1000**, **2000**, and **3000** described with reference to FIGS. 11 to 13 may be one selected from the above-described thermoelectric materials **100**, **200**, **200'**, **300a**, **300b**, **300c**, **400a**, **400b**, and **400c** according to example embodiments, and combinations thereof.

[0122] In FIGS. 11 to 13, electrode structures of the thermoelectric devices **1000**, **2000**, and **3000** are plate-shaped. However, the electrode structures may have other shapes such as wire shapes. If the thermoelectric materials **300** and **400** of FIGS. 9 and 10 in which the multi-walled carbon nanotube arrays **350** and **450** are embedded in the stretchable polymers **120** are used as the thermoelectric materials **TM** of the thermoelectric devices **1000**, **2000**, and **3000**, wire structures may be further used to electrically expose the multi-walled carbon nanotube arrays **350** and **450** to the outsides of the stretchable polymers **120** and to thus electrically connect the first and second electrodes **EL1** and **EL2** to the multi-walled carbon nanotube arrays **350** and **450**. For example, the thermoelectric

materials **300** and **400** may be manufactured by forming wires to be exposed to the outsides on the multi-walled carbon nanotube arrays **350** and **450** using a material such as metal flakes, and then embedding the multi-walled carbon nanotube arrays **350** and **450** in the stretchable polymers **120**.

[0123] Since the thermoelectric devices **1000**, **2000**, and **3000** according to example embodiments include the thermoelectric materials TM having stretchability, the thermoelectric devices **1000**, **2000**, and **3000** may easily be applied to wearable apparatuses such as self-power generating wearable apparatuses.

[0124] FIG. 14 is a schematic block diagram of a wearable electronic apparatus **7000** according to example embodiments.

[0125] The wearable electronic apparatus **7000** may be put on an object OBJ for detecting states of the object OBJ. The wearable electronic apparatus **7000** includes a thermoelectric device **7200** and an operation unit **7400**.

[0126] The thermoelectric device **7200** includes one of the above-described thermoelectric materials according to example embodiments, and a power storage device such as the power storage device ED2 shown in FIG. 12 for storing electricity generated by the thermoelectric material.

[0127] The thermoelectric device **7200** may function as a self-power generating device capable of converting thermal energy TE of the object OBJ into electricity. That is, due to thermal energy provided by the object OBJ, a temperature difference is generated between adjacent and far regions of the thermoelectric device **7200** relative to the object OBJ, and thus electricity is generated in the thermoelectric device **7200** having a temperature gradient. Then, electric energy is stored in the thermoelectric device **7200**.

[0128] The operation unit **7400** may inspect the object OBJ by using electric energy received from the thermoelectric device **7200**. For example, the operation unit **7400** may send an input signal S1 to the object OBJ and may receive an output signal S2 generated from the input signal S1 as a result of interaction with the object OBJ. For example, the input signal S1 may be light or ultrasonic waves, and the output signal S2 may be light or ultrasonic waves modified by interaction with the object OBJ and thus having properties different from those of the input signal S1.

[0129] The operation unit **7400** may be used to inspect the health or motion of the object OBJ. For example, the operation unit **7400** may include a light source or ultrasonic device for generating input signals S1. In addition, the operation unit **7400** may include one or more of various sensors for receiving output signals S2. For example, the operation unit **7400** may include an optical sensor, an ultrasonic sensor, a pressure sensor, or a strain sensor.

[0130] The operation unit **7400** may be controlled in a wired or wireless manner. For example, the operation unit **7400** may be an element of a remote medical examination system capable of measuring the health status of the object OBJ.

[0131] The above-described wearable electronic apparatus **7000** is a non-limiting example. That is, various modifications or changes may be made. For example, any kind of wearable apparatus including a thermoelectric device as a self-power generating device may be provided. For example, example embodiments may provide electronic goggles, watches, or clothes capable of generating electricity from a temperature difference between a human body and the surroundings and using the electricity as operation energy. In

addition, example embodiments may provide military uniforms equipped with such wearable electronic apparatuses.

[0132] As described above, according to example embodiments, thermoelectric materials may have stretchability and high thermoelectric efficiency.

[0133] Therefore, the thermoelectric materials may be used in the manufacture of thermoelectric devices having high thermoelectric conversion efficiency, together with power consuming devices, power storage devices, or power supply devices.

[0134] The thermoelectric devices may be applied to self-power generating wearable electronic apparatuses or other various electronic apparatuses requiring hot spot cooling.

[0135] It should be understood that the example embodiments described herein should be considered in a descriptive sense only and not for purposes of limitation. Descriptions of features or aspects within each thermoelectric material and/or device according to example embodiments should typically be considered as available for other similar features or aspects in other thermoelectric materials and/or devices according to example embodiments.

[0136] While some example embodiments have been described with reference to the figures, it will be understood by those of ordinary skill in the art that various changes in form and details may be made therein without departing from the spirit and scope of the following claims.

What is claimed is:

1. A thermoelectric material comprising:

a stretchable polymer;

a thermoelectric structure and an electrically conductive material that are mixed together with the stretchable polymer.

2. The thermoelectric material of claim 1, wherein the stretchable polymer includes at least one of poly(styrene-isoprene-styrene) (SIS), poly(styrene-butadiene-styrene) (SBS), poly(styrene-ethylene/butylene-styrene) (SEBS), polyvinylidene fluoride (PVDF), nitrile butadiene rubber (NBR), polyurethane (PU), poly(dimethylsiloxane) (PDMS), polyurethane acrylate (PUA), perfluoropolyether (PFPE), polyester (PE), polybutadiene (PB), and polyisoprene.

3. The thermoelectric material of claim 1, wherein the thermoelectric structure includes at least one of an Sb—Te-containing material, a Bi—Te-containing material, a Bi—Sb—Te-containing material, a Co—Sb-containing material, a Pb—Te-containing material, a Ge—Tb-containing material, a Si—Ge-containing material, a Sm—Co-containing material, and a carbon-containing material.

4. The thermoelectric material of claim 3, wherein the carbon-containing material includes at least one of carbon nanotubes, graphene, and graphite.

5. The thermoelectric material of claim 1, wherein the electrically conductive material includes at least one of a carbon nanomaterial and a metallic material.

6. The thermoelectric material of claim 5, wherein the carbon nanomaterial includes at least one of carbon nanotubes, graphene, and graphene nanoparticles.

7. The thermoelectric material of claim 5, wherein the electrically conductive material includes the carbon nanotubes and the metallic material, the metallic material is metal nanoparticles, and the metal nanoparticles are adsorbed on surfaces of the carbon nanotubes.

8. The thermoelectric material of claim 5, wherein the metallic material includes at least one of gold (Au), silver

(Ag), platinum (Pt), copper (Cu), nickel (Ni), aluminum (Al), palladium (Pd), rhodium (Rh), and ruthenium (Ru).

9. The thermoelectric material of claim 1, wherein the thermoelectric structure and the electrically conductive material mixed together are carbon nanotubes and metal nanoparticles, and the metal nanoparticles are adsorbed on surfaces of the carbon nanotubes.
10. The thermoelectric material of claim 1, wherein the thermoelectric structure and the electrically conductive material include carbon nanotubes.
11. The thermoelectric material of claim 10, wherein the carbon nanotubes are a multi-walled carbon nanotubes (MWCNT) array, and the carbon nanotubes are arranged in a direction.
12. The thermoelectric material of claim 11, wherein the multi-walled carbon nanotube array is embedded in the stretchable polymer.
13. The thermoelectric material of claim 12, wherein the stretchable polymer has uniaxial stretchability, and a length of the carbon nanotubes in the multi-walled carbon nanotube array is parallel to a stretching direction of the stretchable polymer.
14. The thermoelectric material of claim 12, wherein the stretchable polymer has uniaxial stretchability, and a length of the carbon nanotubes in the multi-walled carbon nanotube array is perpendicular to a stretching direction of the stretchable polymer.
15. A thermoelectric device comprising:
the thermoelectric material of claim 1; and
a first electrode and a second electrode electrically connected to respective ends of the thermoelectric material.
16. The thermoelectric device of claim 15, further comprising:
an electronic device electrically connected to the first and second electrodes.
17. The thermoelectric device of claim 16, wherein the electronic device is one of a power consuming device, a power storage device, and power supply device.
18. A wearable electronic apparatus configured to be put on an object for inspecting the object, the wearable electronic apparatus comprising:
the thermoelectric material of claim 1;
a first electrode and a second electrode electrically connected to respective ends of the thermoelectric material;
a power storage device connected to the first and second electrodes,
the power storage device configured to store electric energy generated in the thermoelectric material based on a temperature difference between both the ends of the thermoelectric material, the temperature difference being based on heat provided by the object; and
an operation unit configured to receive the electric energy from the power storage device and to perform an inspection operation on the object.
19. The wearable electronic apparatus of claim 18, wherein the operation unit is configured to measure a health status or a motion of the object.
20. An electronic apparatus comprising:
the thermoelectric material of claim 1;
a first electrode and a second electrode electrically connected to respective ends of the thermoelectric material; and
a power supply device connected to the first and second electrodes,
the power supply device configured to supply a current to the thermoelectric material so as to form a hot spot cooling region at one of the respective ends of the of the thermoelectric material.
21. A thermoelectric material, comprising:
a stretchable polymer;
a thermoelectric structure mixed in the stretchable polymer, the thermoelectric structure containing carbon; and
an electrically conductive material mixed in the stretchable polymer.
22. The thermoelectric material of claim 21, wherein the stretchable polymer includes at least one of poly(styrene-isoprene-styrene) (SIS), poly(styrene-butadiene-styrene) (SBS), poly(styrene-ethylene/butylene-styrene) (SEBS), polyvinylidene fluoride (PVDF), nitrile butadiene rubber (NBR), polyurethane (PU), poly(dimethylsiloxane) (PDMS), polyurethane acrylate (PUA), perfluoropolyether (PFPE), polyester (PE), polybutadiene (PB), and polyisoprene.
23. The thermoelectric material of claim 21, wherein the electrically conductive material includes metal nanoparticles.
24. The thermoelectric material of claim 23, wherein the thermoelectric structure includes carbon nanotubes embedded in the stretchable polymer, and the metal nanoparticles are adsorbed on the carbon nanotubes.
25. The thermoelectric material of claim 23, wherein the carbon nanotubes are arranged in an array, and lengths of the carbon nanotubes are parallel to each other.

* * * * *

专利名称(译)	可拉伸的热电材料和包括其的热电装置		
公开(公告)号	US20150342523A1	公开(公告)日	2015-12-03
申请号	US14/724220	申请日	2015-05-28
[标]申请(专利权)人(译)	三星电子株式会社		
申请(专利权)人(译)	SAMSUNG ELECTRONICS CO. , LTD.		
当前申请(专利权)人(译)	研究与业务基础韩国成均馆大学		
[标]发明人	BAIK SEUNGHYUN SUH DAEWOO LEE DONGMOK LEE SANGHOON		
发明人	BAIK, SEUNGHYUN SUH, DAEWOO LEE, DONGMOK LEE, SANGHOON		
IPC分类号	A61B5/00 H01L35/16 H01L35/18 H02J7/35 H01L35/20 H01M10/46 A61B5/11 H01L35/32 H01L35/22		
CPC分类号	A61B5/6801 H01L35/32 H01L35/16 H01L35/18 A61B2560/0219 H01L35/20 H01M10/46 A61B5/1118 H02J7/355 H01L35/22 A61B5/6802 A61B5/6831 A61B2562/0276 A61B2562/12 H01L35/24 H01L35/26 H02J7/35		
优先权	1020140066523 2014-05-30 KR		
其他公开文献	US10136854		
外部链接	Espacenet USPTO		

摘要(译)

热电材料包括可拉伸聚合物，以及与可拉伸聚合物混合在一起的热电结构和导电材料。热电材料可以应用于自发电可穿戴电子设备。

