



US010525288B2

(12) **United States Patent**  
**Slayton et al.**

(10) **Patent No.:** **US 10,525,288 B2**  
(45) **Date of Patent:** **\*Jan. 7, 2020**

(54) **SYSTEM AND METHOD FOR NONINVASIVE SKIN TIGHTENING**

(71) Applicant: **Guided Therapy Systems, LLC**, Mesa, AZ (US)

(72) Inventors: **Michael H. Slayton**, Tempe, AZ (US);  
**Peter G. Barthe**, Phoenix, AZ (US);  
**Inder Raj S. Makin**, Mesa, AZ (US);  
**Brian D. O'Connor**, Phoenix, AZ (US)

(73) Assignee: **Guided Therapy Systems, LLC**, Mesa, AZ (US)

(\* ) Notice: Subject to any disclaimer, the term of this patent is extended or adjusted under 35 U.S.C. 154(b) by 0 days.

This patent is subject to a terminal disclaimer.

(21) Appl. No.: **15/958,939**

(22) Filed: **Apr. 20, 2018**

(65) **Prior Publication Data**  
US 2018/0236273 A1 Aug. 23, 2018

**Related U.S. Application Data**

(63) Continuation of application No. 15/098,139, filed on Apr. 13, 2016, now Pat. No. 9,974,982, which is a (Continued)

(51) **Int. Cl.**  
**A61N 7/02** (2006.01)  
**A61B 5/00** (2006.01)  
(Continued)

(52) **U.S. Cl.**  
CPC ..... **A61N 7/02** (2013.01); **A61B 5/682** (2013.01); **A61B 5/6842** (2013.01); **A61B 8/08** (2013.01);  
(Continued)

(58) **Field of Classification Search**  
CPC ..... A61N 2007/027; A61N 2007/025; A61N 7/02  
See application file for complete search history.

(56) **References Cited**

U.S. PATENT DOCUMENTS

2,427,348 A 9/1947 Bond et al.  
2,792,829 A 2/1952 Calosi  
(Continued)

FOREIGN PATENT DOCUMENTS

CN 100565240 12/2009  
CN 104027893 9/2014  
(Continued)

OTHER PUBLICATIONS

Agren, Magnus S. et al., Collagenase in Wound Healing: Effect of Wound Age and Type. The Journal of Investigative Dermatology, vol. 99/No. 6, (Dec. 1992).

(Continued)

*Primary Examiner* — Ronald Hupczey, Jr.

(74) *Attorney, Agent, or Firm* — Knobbe Martens Olson & Bear LLP

(57) **ABSTRACT**

A method and system for noninvasive face lifts and deep tissue tightening are disclosed. An exemplary method and treatment system are configured for the imaging, monitoring, and thermal injury to treat the SMAS region. In accordance with an exemplary embodiment, the exemplary method and system are configured for treating the SMAS region by first, imaging of the region of interest for localization of the treatment area and surrounding structures, second, delivery of ultrasound energy at a depth, distribution, timing, and energy level to achieve the desired therapeutic effect, and third to monitor the treatment area before, during, and after therapy to plan and assess the results and/or provide feedback.

**20 Claims, 28 Drawing Sheets**

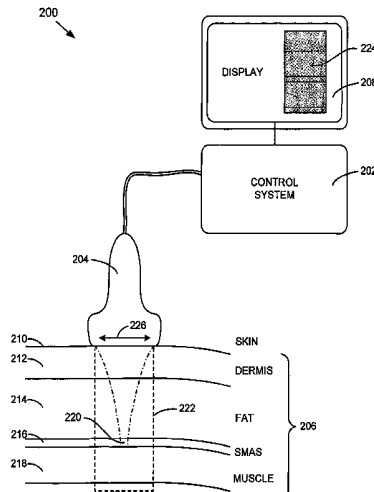

- Related U.S. Application Data**
- continuation of application No. 13/964,820, filed on Aug. 12, 2013, now Pat. No. 9,320,537, which is a continuation of application No. 12/028,636, filed on Aug. 2, 2008, now Pat. No. 8,535,228, which is a continuation-in-part of application No. 11/163,151, filed on Oct. 6, 2005, now abandoned, and a continuation-in-part of application No. 11/163,148, filed on Oct. 6, 2005, now abandoned.
- (60) Provisional application No. 60/616,755, filed on Oct. 6, 2004, provisional application No. 60/616,754, filed on Oct. 6, 2004.
- (51) **Int. Cl.**  
*A61B 8/08* (2006.01)  
*A61B 8/12* (2006.01)  
*A61B 8/00* (2006.01)  
*A61H 23/02* (2006.01)  
*A61N 7/00* (2006.01)  
*G01S 15/89* (2006.01)  
*A61B 17/32* (2006.01)
- (52) **U.S. Cl.**  
 CPC ..... *A61B 8/0858* (2013.01); *A61B 8/12* (2013.01); *A61B 8/4483* (2013.01); *A61B 8/483* (2013.01); *A61B 8/546* (2013.01); *A61H 23/0245* (2013.01); *A61N 7/00* (2013.01); *G01S 15/8909* (2013.01); *A61B 8/4281* (2013.01); *A61B 8/4455* (2013.01); *A61B 2017/320069* (2017.08); *A61H 2201/5007* (2013.01); *A61H 2230/50* (2013.01); *A61N 2007/0008* (2013.01); *A61N 2007/0034* (2013.01); *G01S 15/899* (2013.01)
- (56) **References Cited**
- U.S. PATENT DOCUMENTS
- |             |         |                |             |         |                   |
|-------------|---------|----------------|-------------|---------|-------------------|
| 3,913,386 A | 10/1975 | Saglio         | 4,601,296 A | 7/1986  | Yerushalmi        |
| 3,965,455 A | 6/1976  | Hurwitz        | 4,620,546 A | 11/1986 | Aida et al.       |
| 3,992,925 A | 11/1976 | Perilhau       | 4,637,256 A | 1/1987  | Sugiyama et al.   |
| 4,039,312 A | 8/1977  | Patru          | 4,646,756 A | 3/1987  | Watmough          |
| 4,059,098 A | 11/1977 | Murdock        | 4,663,358 A | 5/1987  | Hyon              |
| 4,101,795 A | 7/1978  | Fukumoto       | 4,668,516 A | 5/1987  | Duraffourd et al. |
| 4,151,834 A | 5/1979  | Sato et al.    | 4,672,591 A | 6/1987  | Breimesser et al. |
| 4,166,967 A | 9/1979  | Benes et al.   | 4,680,499 A | 7/1987  | Umemura et al.    |
| 4,211,948 A | 7/1980  | Smith et al.   | 4,697,588 A | 10/1987 | Reichenberger     |
| 4,211,949 A | 7/1980  | Brisken et al. | 4,754,760 A | 7/1988  | Fukukita et al.   |
| 4,213,344 A | 7/1980  | Rose           | 4,757,820 A | 7/1988  | Itoh              |
| 4,276,491 A | 6/1981  | Daniel         | 4,771,205 A | 9/1988  | Mequoio           |
| 4,315,514 A | 2/1982  | Drewes et al.  | 4,801,459 A | 1/1989  | Liburdy           |
| 4,325,381 A | 4/1982  | Glenn          | 4,803,625 A | 2/1989  | Fu et al.         |
| 4,343,301 A | 8/1982  | Indech         | 4,807,633 A | 2/1989  | Fry               |
| 4,372,296 A | 2/1983  | Fahim          | 4,817,615 A | 4/1989  | Fukukita et al.   |
| 4,379,145 A | 4/1983  | Masuh et al.   | 4,858,613 A | 8/1989  | Fry               |
| 4,381,007 A | 4/1983  | Doss           | 4,860,732 A | 8/1989  | Hasegawa et al.   |
| 4,381,787 A | 5/1983  | Hottinger      | 4,865,041 A | 9/1989  | Hassler           |
| 4,397,314 A | 8/1983  | Vaguine        | 4,865,042 A | 9/1989  | Umemura           |
| 4,409,839 A | 10/1983 | Taenzer        | 4,867,169 A | 9/1989  | Machida           |
| 4,431,008 A | 2/1984  | Wanner et al.  | 4,874,562 A | 10/1989 | Hyon              |
| 4,441,486 A | 4/1984  | Pounds         | 4,875,487 A | 10/1989 | Seppi             |
| 4,452,084 A | 6/1984  | Taenzer        | 4,881,212 A | 11/1989 | Takeuchi          |
| 4,484,569 A | 11/1984 | Driller        | 4,891,043 A | 1/1990  | Zeimer et al.     |
| 4,507,582 A | 3/1985  | Glenn          | 4,893,624 A | 1/1990  | Lele              |
| 4,513,749 A | 4/1985  | Kino           | 4,896,673 A | 1/1990  | Rose              |
| 4,513,750 A | 4/1985  | Heyman et al.  | 4,900,540 A | 2/1990  | Ryan et al.       |
| 4,527,550 A | 7/1985  | Ruggera et al. | 4,901,729 A | 2/1990  | Saitoh            |
| 4,528,979 A | 7/1985  | Marchenko      | 4,917,096 A | 4/1990  | Englehart         |
| 4,534,221 A | 8/1985  | Fife et al.    | 4,932,414 A | 6/1990  | Coleman et al.    |
| 4,566,459 A | 1/1986  | Umemura et al. | 4,938,216 A | 7/1990  | Lele              |
| 4,567,895 A | 2/1986  | Putzke         | 4,938,217 A | 7/1990  | Lele              |
| 4,586,512 A | 5/1986  | Do-Huu         | 4,947,046 A | 8/1990  | Kawabata et al.   |
|             |         |                | 4,951,653 A | 8/1990  | Fry               |
|             |         |                | 4,955,365 A | 9/1990  | Fry               |
|             |         |                | 4,958,626 A | 9/1990  | Nambu             |
|             |         |                | 4,976,709 A | 12/1990 | Sand              |
|             |         |                | 4,979,501 A | 12/1990 | Valchanov         |
|             |         |                | 4,992,989 A | 2/1991  | Watanabe et al.   |
|             |         |                | 5,012,797 A | 5/1991  | Liang             |
|             |         |                | 5,018,508 A | 5/1991  | Fry et al.        |
|             |         |                | 5,030,874 A | 7/1991  | Saito et al.      |
|             |         |                | 5,036,855 A | 8/1991  | Fry               |
|             |         |                | 5,040,537 A | 8/1991  | Katakura          |
|             |         |                | 5,054,310 A | 10/1991 | Flynn             |
|             |         |                | 5,054,470 A | 10/1991 | Fry               |
|             |         |                | 5,054,491 A | 10/1991 | Saito et al.      |
|             |         |                | 5,070,879 A | 12/1991 | Herres            |
|             |         |                | 5,088,495 A | 2/1992  | Miyagawa          |
|             |         |                | 5,115,814 A | 5/1992  | Griffith          |
|             |         |                | 5,117,832 A | 6/1992  | Sanghvi           |
|             |         |                | 5,123,418 A | 6/1992  | Saurel            |
|             |         |                | 5,142,511 A | 8/1992  | Kanai et al.      |
|             |         |                | 5,143,063 A | 9/1992  | Fellner           |
|             |         |                | 5,143,074 A | 9/1992  | Dory              |
|             |         |                | 5,149,319 A | 9/1992  | Unger             |
|             |         |                | 5,150,711 A | 9/1992  | Dory              |
|             |         |                | 5,150,714 A | 9/1992  | Green             |
|             |         |                | 5,152,294 A | 10/1992 | Mochizuki et al.  |
|             |         |                | 5,156,144 A | 10/1992 | Iwasaki           |
|             |         |                | 5,158,536 A | 10/1992 | Sekins            |
|             |         |                | 5,159,931 A | 11/1992 | Pini              |
|             |         |                | 5,163,421 A | 11/1992 | Bernstein         |
|             |         |                | 5,163,436 A | 11/1992 | Saitoh et al.     |
|             |         |                | 5,178,135 A | 1/1993  | Uchiyama et al.   |
|             |         |                | 5,190,518 A | 3/1993  | Takasu            |
|             |         |                | 5,190,766 A | 3/1993  | Ishihara          |
|             |         |                | 5,191,880 A | 3/1993  | McLeod            |
|             |         |                | 5,205,287 A | 4/1993  | Erbel et al.      |
|             |         |                | 5,209,720 A | 5/1993  | Unger             |
|             |         |                | 5,212,671 A | 5/1993  | Fujii et al.      |
|             |         |                | 5,215,680 A | 6/1993  | D'Arrigo          |
|             |         |                | 5,224,467 A | 7/1993  | Oku               |
|             |         |                | 5,230,334 A | 7/1993  | Klopotek          |
|             |         |                | 5,230,338 A | 7/1993  | Allen et al.      |
|             |         |                | 5,247,924 A | 9/1993  | Suzuki et al.     |
|             |         |                | 5,255,681 A | 10/1993 | Ishimura et al.   |
|             |         |                | 5,257,970 A | 11/1993 | Dougherty         |

(56)

## References Cited

## U.S. PATENT DOCUMENTS

5,265,614 A	11/1993	Hayakawa	5,605,154 A	2/1997	Ries et al.
5,267,985 A	12/1993	Shimada	5,609,562 A	3/1997	Kaali
5,269,297 A	12/1993	Weng	5,615,091 A	3/1997	Palatnik
5,282,797 A	2/1994	Chess	5,618,275 A	4/1997	Bock
5,295,484 A	3/1994	Marcus	5,620,479 A	4/1997	Diederich
5,295,486 A	3/1994	Wollschlager et al.	5,622,175 A	4/1997	Sudol et al.
5,304,169 A	4/1994	Sand	5,617,858 A	5/1997	Taverna et al.
5,305,756 A	4/1994	Entrekin et al.	5,638,819 A	6/1997	Manwaring et al.
5,321,520 A	6/1994	Inga et al.	5,644,085 A	7/1997	Lorraine et al.
5,323,779 A	6/1994	Hardy et al.	5,647,373 A	7/1997	Paltieli
5,327,895 A	7/1994	Hashimoto et al.	5,655,535 A	8/1997	Frlemel et al.
5,329,202 A	7/1994	Garlick et al.	5,655,538 A	8/1997	Lorraine
5,348,016 A	9/1994	Unger et al.	5,657,760 A	8/1997	Ying
5,358,466 A	10/1994	Aida et al.	5,658,328 A	8/1997	Johnson
5,360,268 A	11/1994	Hayashi	5,660,836 A	8/1997	Knowlton
5,370,121 A	12/1994	Reichenberger	5,662,116 A	9/1997	Kondo
5,370,122 A	12/1994	Kunig	5,665,053 A	9/1997	Jacobs
5,371,483 A	12/1994	Bhardwaj	5,665,141 A	9/1997	Vago
5,375,602 A	12/1994	Lancee et al.	5,671,746 A	9/1997	Dreschel et al.
5,379,773 A	1/1995	Hornsby	5,673,699 A	10/1997	Trahey et al.
5,380,280 A	1/1995	Peterson	5,676,692 A	10/1997	Sanghvi
5,380,519 A	1/1995	Schneider et al.	5,685,820 A	11/1997	Riek et al.
5,383,917 A	1/1995	Desai et al.	5,690,608 A	11/1997	Watanabe
5,391,140 A	2/1995	Schaetzle et al.	5,694,936 A	12/1997	Fujimoto
5,391,197 A	2/1995	Burdette et al.	5,697,897 A	12/1997	Buchholtz
5,392,259 A	2/1995	Bolorforosh	5,701,900 A	12/1997	Shehada et al.
5,396,143 A	3/1995	Seyed-Bolorforosh et al.	5,704,361 A	1/1998	Seward et al.
5,398,689 A	3/1995	Connor et al.	5,706,252 A	1/1998	Le Verrier et al.
5,406,503 A	4/1995	Williams	5,706,564 A	1/1998	Rhyne
5,413,550 A	5/1995	Castel	5,715,823 A	2/1998	Wood et al.
5,417,216 A	5/1995	Tanaka	5,720,287 A	2/1998	Chapelon et al.
5,423,220 A	6/1995	Finsterwald et al.	5,722,411 A	3/1998	Suzuki
5,435,311 A	7/1995	Umemura	5,727,554 A	3/1998	Kalend et al.
5,438,998 A	8/1995	Hanafy	5,735,280 A	4/1998	Sherman et al.
5,443,068 A	8/1995	Cline et al.	5,743,863 A	4/1998	Chapelon
5,445,611 A	8/1995	Eppstein et al.	5,746,005 A	5/1998	Steinberg
5,458,596 A	10/1995	Lax	5,746,762 A	5/1998	Bass
5,460,179 A	10/1995	Okunuki et al.	5,748,767 A	5/1998	Raab
5,460,595 A	10/1995	Hall et al.	5,749,364 A	5/1998	Sliwa et al.
5,419,327 A	11/1995	Rohwedder	5,755,228 A	5/1998	Wilson et al.
5,469,854 A	11/1995	Unger et al.	5,755,753 A	5/1998	Knowlton
5,471,488 A	12/1995	Fujio	5,762,066 A	6/1998	Law
5,472,405 A	12/1995	Buchholtz et al.	5,763,886 A	6/1998	Schulte
5,487,388 A	1/1996	Rello et al.	5,769,790 A	6/1998	Watkins
5,492,126 A	2/1996	Hennige	5,779,644 A	7/1998	Eberle et al.
5,496,256 A	3/1996	Bock	5,792,058 A	8/1998	Lee
5,501,655 A	3/1996	Rolt	5,795,297 A	8/1998	Daigle
5,503,152 A	4/1996	Oakley et al.	5,795,311 A	8/1998	Wess
5,503,320 A	4/1996	Webster et al.	5,810,009 A	9/1998	Mine et al.
5,507,790 A	4/1996	Weiss	5,810,888 A	9/1998	Fenn
5,511,296 A	4/1996	Dias et al.	5,814,599 A	9/1998	Mitragotri et al.
5,520,188 A	5/1996	Hennige	5,817,013 A	10/1998	Ginn et al.
5,522,869 A	6/1996	Burdette	5,817,021 A	10/1998	Reichenberger
5,523,058 A	6/1996	Umemura et al.	5,820,564 A	10/1998	Slayton
5,524,620 A	6/1996	Rosenchein	5,823,962 A	10/1998	Schaetzle
5,524,624 A	6/1996	Tepper	5,827,204 A	10/1998	Grandia et al.
5,524,625 A	6/1996	Okazaki	5,840,032 A	11/1998	Hatfield et al.
5,526,624 A	6/1996	Berg	5,844,140 A	12/1998	Seale
5,526,812 A	6/1996	Dumoulin et al.	5,853,367 A	12/1998	Chalek et al.
5,526,814 A	6/1996	Cline et al.	5,869,751 A	2/1999	Bonin
5,526,815 A	6/1996	Granz	5,871,524 A	2/1999	Knowlton
5,529,070 A	6/1996	Augustine et al.	5,873,902 A	2/1999	Sanghvi
5,540,235 A	7/1996	Wilson	5,876,341 A	3/1999	Wang et al.
5,558,092 A	9/1996	Unger	5,879,303 A	3/1999	Averkiou et al.
5,560,362 A	10/1996	Sliwa et al.	5,882,557 A	3/1999	Hayakawa
5,573,497 A	11/1996	Chapelon	5,891,034 A	4/1999	Bucholz
5,575,291 A	11/1996	Hayakawa	5,895,356 A	4/1999	Andrus et al.
5,575,807 A	11/1996	Faller	5,899,861 A	5/1999	Frlemel et al.
5,577,502 A	11/1996	Darrow et al.	5,904,659 A	5/1999	Duarte
5,577,507 A	11/1996	Snyder et al.	5,919,219 A	7/1999	Knowlton
5,577,991 A	11/1996	Akui et al.	5,923,099 A	7/1999	Bilir
5,580,575 A	12/1996	Unger et al.	5,924,989 A	7/1999	Polz
5,643,179 A	1/1997	Fujimoto	5,928,169 A	7/1999	Schatzle et al.
5,601,526 A	2/1997	Chapelon	5,931,805 A	8/1999	Brisken
5,603,323 A	2/1997	Pflugrath et al.	5,938,606 A	8/1999	Bonnefous
			5,938,612 A	8/1999	Kline-Schoder
			5,948,011 A	9/1999	Knowlton
			5,957,844 A	9/1999	Dekel
			5,957,882 A	9/1999	Nita et al.

(56)

References Cited

U.S. PATENT DOCUMENTS

5,957,941 A	9/1999	Ream	6,311,090 B1	10/2001	Knowlton
5,964,707 A	10/1999	Fenster et al.	6,315,741 B1	11/2001	Martin
5,967,980 A	10/1999	Ferre et al.	6,322,509 B1	11/2001	Pan et al.
5,968,034 A	10/1999	Fullmer	6,322,532 B1	11/2001	D'Sa
5,971,949 A	10/1999	Levin	6,325,540 B1	12/2001	Lounsberry et al.
5,977,538 A	11/1999	Unger et al.	6,325,758 B1	12/2001	Carol et al.
5,984,881 A	11/1999	Ishibashi et al.	6,325,769 B1	12/2001	Klopotek
5,984,882 A	11/1999	Rosenchein	6,325,798 B1	12/2001	Edwards et al.
5,990,598 A	11/1999	Sudol et al.	6,350,276 B1	2/2002	Knowlton
5,997,471 A	12/1999	Gumb et al.	6,356,780 B1	3/2002	Licato et al.
5,997,497 A	12/1999	Nita et al.	6,361,531 B1	3/2002	Hissong
5,999,843 A	12/1999	Anbar	6,370,411 B1	4/2002	Osadchy et al.
6,004,262 A	12/1999	Putz et al.	6,375,672 B1	4/2002	Aksan
6,007,499 A	12/1999	Martin et al.	6,377,854 B1	4/2002	Knowlton
6,013,032 A	1/2000	Savord	6,377,855 B1	4/2002	Knowlton
6,014,473 A	1/2000	Hossack et al.	6,381,497 B1	4/2002	Knowlton
6,016,255 A	1/2000	Bolan et al.	6,381,498 B1	4/2002	Knowlton
6,019,724 A	2/2000	Gronningsaeter et al.	6,387,380 B1	5/2002	Knowlton
6,022,308 A	2/2000	Williams	6,390,982 B1	5/2002	Bova et al.
6,022,317 A	2/2000	Cruanas et al.	6,405,090 B1	6/2002	Knowlton
6,022,327 A	2/2000	Chang	6,409,720 B1	6/2002	Hissong
6,030,374 A	2/2000	McDaniel	6,413,216 B1	7/2002	Cain et al.
6,036,646 A	3/2000	Barthe	6,413,253 B1	7/2002	Koop
6,039,048 A	3/2000	Silberg	6,413,254 B1	7/2002	Hissong
6,039,689 A	3/2000	Lizzi	6,419,648 B1	7/2002	Vitek
6,042,556 A	3/2000	Beach	6,423,007 B2	7/2002	Lizzi et al.
6,049,159 A	4/2000	Barthe	6,425,865 B1	7/2002	Salcudean
6,050,943 A	4/2000	Slayton	6,425,867 B1	7/2002	Vaezy
6,059,727 A	5/2000	Fowlkes	6,425,912 B1	7/2002	Knowlton
6,071,239 A	6/2000	Cribbs	6,428,477 B1	8/2002	Mason
6,080,108 A	6/2000	Dunham	6,428,532 B1	8/2002	Doukas
6,083,148 A	7/2000	Williams	6,430,446 B1	8/2002	Knowlton
6,086,535 A	7/2000	Ishibashi	6,432,057 B1	8/2002	Mazess et al.
6,086,580 A	7/2000	Mordon et al.	6,432,067 B1	8/2002	Martin
6,090,054 A	7/2000	Tagishi	6,432,101 B1	8/2002	Weber
6,093,148 A	7/2000	Fujimoto	6,436,061 B1	8/2002	Costantino
6,093,883 A	7/2000	Sanghvi	6,438,424 B1	8/2002	Knowlton
6,101,407 A	8/2000	Groezinger	6,440,071 B1	8/2002	Slayton
6,106,469 A	8/2000	Suzuki et al.	6,440,121 B1	8/2002	Weber
6,113,558 A	9/2000	Rosenchein	6,443,914 B1	9/2002	Costantino
6,113,559 A *	9/2000	Klopotek ..... A61N 7/00 601/3	6,447,443 B1	9/2002	Keogh et al.
6,120,452 A	9/2000	Barthe	6,450,979 B1	9/2002	Miwa et al.
6,123,081 A	9/2000	Durette	6,451,013 B1	9/2002	Bays et al.
6,126,619 A	10/2000	Peterson et al.	6,453,202 B1	9/2002	Knowlton
6,135,971 A	10/2000	Hutchinson	6,461,304 B1	10/2002	Tanaka et al.
6,139,499 A	10/2000	Wilk	6,461,378 B1	10/2002	Knowlton
6,159,150 A	12/2000	Yale et al.	6,470,216 B1	10/2002	Knowlton
6,171,244 B1	1/2001	Finger et al.	6,338,716 B1	11/2002	Hossack
6,176,840 B1	1/2001	Nishimura	6,488,626 B1	12/2002	Lizzi
6,183,426 B1	2/2001	Akisada	6,491,657 B2	12/2002	Rowe
6,183,502 B1	2/2001	Takeuchi	6,500,121 B1 *	12/2002	Slayton ..... A61B 5/01 600/439
6,183,773 B1	2/2001	Anderson	6,500,141 B1	12/2002	Irion
6,190,323 B1	2/2001	Dias	6,506,171 B1	1/2003	Vitek et al.
6,190,336 B1	2/2001	Duarte	6,508,774 B1	1/2003	Acker
6,193,658 B1	2/2001	Wendelken	6,511,427 B1	1/2003	Sliwa, Jr. et al.
6,198,956 B1	3/2001	Dunne	6,511,428 B1	1/2003	Azuma
6,210,327 B1	4/2001	Brackett et al.	6,514,244 B2	2/2003	Pope
6,213,948 B1	4/2001	Barthe	6,517,484 B1	2/2003	Wilk
6,216,029 B1	4/2001	Paltieli	6,524,250 B1	2/2003	Weber
6,233,476 B1	5/2001	Strommer et al.	6,666,835 B2	3/2003	Martin
6,234,990 B1	5/2001	Rowe et al.	6,540,679 B2	4/2003	Slayton
6,241,753 B1	6/2001	Knowlton	6,540,685 B1	4/2003	Rhoads et al.
6,246,898 B1	6/2001	Vesely et al.	6,540,700 B1	4/2003	Fujimoto et al.
6,251,074 B1	6/2001	Averkiou et al.	6,547,788 B1	4/2003	Maguire et al.
6,251,088 B1	6/2001	Kaufman et al.	6,554,771 B1	4/2003	Buil et al.
6,268,405 B1	7/2001	Yao	6,569,099 B1	5/2003	Babaev
6,273,864 B1	8/2001	Duarte	6,569,108 B2	5/2003	Sarvazyan et al.
6,280,402 B1	8/2001	Ishibashi et al.	6,572,552 B2	6/2003	Fukukita
6,287,257 B1	9/2001	Maticchuk	6,575,956 B1	6/2003	Brisken et al.
6,287,304 B1	9/2001	Eggers et al.	6,595,934 B1 *	7/2003	Hissong ..... A61N 7/02 601/3
6,296,619 B1	10/2001	Brisken	6,599,256 B1	7/2003	Acker
6,301,989 B1	10/2001	Brown et al.	6,605,043 B1	8/2003	Dreschel
6,307,302 B1	10/2001	Toda	6,605,080 B1	8/2003	Altschuler et al.
6,309,355 B1	10/2001	Cain et al.	6,607,498 B2	8/2003	Eshel
			6,618,620 B1	9/2003	Freundlich et al.
			6,623,430 B1	9/2003	Slayton
			6,626,854 B2	9/2003	Friedman

(56)

## References Cited

## U.S. PATENT DOCUMENTS

6,626,855	B1	9/2003	Weng	7,331,951	B2	2/2008	Eshel et al.
6,638,226	B2	10/2003	He et al.	7,332,985	B2	2/2008	Larson et al.
6,645,145	B1	11/2003	Dreschel et al.	7,338,434	B1	3/2008	Haarstad et al.
6,645,150	B2	11/2003	Angelsen et al.	7,347,855	B2	3/2008	Eshel
6,645,162	B2	11/2003	Friedman	RE40,403	E	6/2008	Cho et al.
6,662,054	B2	12/2003	Kreindel	7,393,325	B2	7/2008	Barthe
6,663,627	B2	12/2003	Francischelli	7,398,116	B2	7/2008	Edwards
6,665,806	B1	12/2003	Shimizu	7,399,279	B2	7/2008	Abend et al.
6,669,638	B1	12/2003	Miller	7,491,171	B2	2/2009	Barthe et al.
6,685,639	B1	2/2004	Wang et al.	7,507,235	B2	3/2009	Keogh et al.
6,685,640	B1	2/2004	Fry	7,510,536	B2	3/2009	Foley et al.
6,692,450	B1	2/2004	Coleman	7,517,315	B2	4/2009	Willis
6,699,237	B2	3/2004	Weber	7,530,356	B2	5/2009	Slayton
6,716,184	B2	4/2004	Vaezy et al.	7,530,958	B2	5/2009	Slayton
6,719,449	B1	4/2004	Laughlin	7,532,201	B2	5/2009	Quistgaard et al.
6,719,694	B2	4/2004	Weng	7,571,336	B2	8/2009	Barthe
6,726,627	B1	4/2004	Lizzi et al.	7,601,120	B2	10/2009	Moilanen et al.
6,733,449	B1	5/2004	Krishnamurthy et al.	7,615,015	B2	11/2009	Coleman
6,749,624	B2	6/2004	Knowlton	7,615,016	B2	11/2009	Barthe
6,772,490	B2	8/2004	Toda	7,652,411	B2	1/2010	Crunkilton et al.
6,773,409	B2	8/2004	Truckai et al.	7,662,114	B2	2/2010	Seip et al.
6,775,404	B1	8/2004	Pagoulatos et al.	7,674,257	B2	3/2010	Pless et al.
6,790,187	B2	9/2004	Thompson et al.	7,686,763	B2	3/2010	Vaezy et al.
6,824,516	B2	11/2004	Batten et al.	7,713,203	B2	3/2010	Lacoste et al.
6,825,176	B2	11/2004	White et al.	7,694,406	B2	4/2010	Wildes et al.
6,835,940	B2	12/2004	Morikawa et al.	7,695,437	B2	4/2010	Quistgaard et al.
6,846,290	B2*	1/2005	Lizzi .....	7,727,156	B2	6/2010	Angelsen et al.
				7,758,524	B2	7/2010	Barthe
				7,766,848	B2	8/2010	Desilets et al.
				7,789,841	B2	9/2010	Huckle et al.
			A61B 8/0858	7,806,839	B2	10/2010	Mast et al.
			600/439	7,815,570	B2	10/2010	Eshel et al.
6,875,176	B2	4/2005	Mourad et al.	7,819,826	B2	10/2010	Diederich et al.
6,882,884	B1	4/2005	Mosk et al.	7,828,734	B2	10/2010	Azhari et al.
6,887,239	B2	5/2005	Elstrom	7,824,348	B2	11/2010	Barthe
6,889,089	B2	5/2005	Behl	7,833,162	B2	11/2010	Hasegawa et al.
6,896,657	B2	5/2005	Willis	7,841,984	B2	11/2010	Cribbs et al.
6,902,536	B2	6/2005	Manna	7,846,096	B2	12/2010	Mast et al.
6,905,466	B2	6/2005	Salgo	7,857,773	B2	12/2010	Desilets et al.
6,918,907	B2	7/2005	Kelly	7,875,023	B2	1/2011	Eshel et al.
6,920,883	B2	7/2005	Bessette	7,901,359	B2	3/2011	Mandrusov et al.
6,921,371	B2	7/2005	Wilson	7,905,007	B2	3/2011	Calisti et al.
6,932,771	B2	8/2005	Whitmore	7,905,844	B2	3/2011	Desilets et al.
6,932,814	B2	8/2005	Wood	7,914,453	B2	3/2011	Slayton et al.
6,936,044	B2	8/2005	McDaniel	7,914,469	B2	3/2011	Torbati
6,936,046	B2	8/2005	Hissong	7,955,281	B2	6/2011	Pedersen et al.
6,945,937	B2	9/2005	Culp et al.	7,967,764	B2	6/2011	Lidgren et al.
6,948,843	B2	9/2005	Laugharn et al.	7,967,839	B2	6/2011	Flock et al.
6,953,941	B2	10/2005	Nakano et al.	7,955,262	B2	7/2011	Rosenberg
6,958,043	B2	10/2005	Hissong	7,993,289	B2	8/2011	Quistgaard et al.
6,971,994	B1	12/2005	Young et al.	8,057,465	B2	9/2011	Sliwa, Jr. et al.
6,974,417	B2	12/2005	Lockwood	8,057,389	B2	11/2011	Barthe et al.
6,976,492	B2	12/2005	Ingle	8,066,641	B2	11/2011	Barthe et al.
6,992,305	B2	1/2006	Maezawa et al.	8,123,707	B2	2/2012	Huckle et al.
6,997,923	B2	2/2006	Anderson	8,128,618	B2	3/2012	Gliklich et al.
7,006,874	B2	2/2006	Knowlton	8,133,180	B2	3/2012	Slayton et al.
7,020,528	B2	3/2006	Neev	8,133,191	B2	3/2012	Rosenberg et al.
7,022,089	B2	4/2006	Ooba	8,142,200	B2	3/2012	Crunkilton et al.
7,058,440	B2	6/2006	Heuscher et al.	8,152,904	B2	4/2012	Slobodzian et al.
7,063,666	B2	6/2006	Weng	8,162,858	B2	4/2012	Manna et al.
7,070,565	B2	7/2006	Vaezy et al.	8,166,332	B2	4/2012	Barthe et al.
7,074,218	B2	7/2006	Washington et al.	8,182,428	B2	5/2012	Angelsen et al.
7,094,252	B2	8/2006	Koop	8,197,409	B2	6/2012	Foley et al.
7,108,663	B2	9/2006	Talish et al.	8,206,299	B2	6/2012	Foley et al.
7,115,123	B2	10/2006	Knowlton	8,208,346	B2	6/2012	Crunkilton
7,122,029	B2	10/2006	Koop et al.	8,211,017	B2	7/2012	Foley et al.
7,142,905	B2	11/2006	Slayton	8,262,591	B2	9/2012	Pedersen et al.
7,165,451	B1	1/2007	Brooks et al.	8,262,650	B2	9/2012	Zanelli et al.
7,179,238	B2	2/2007	Hissong	8,264,126	B2	9/2012	Toda et al.
7,189,230	B2	3/2007	Knowlton	8,273,037	B2	9/2012	Kreindel et al.
7,229,411	B2	6/2007	Slayton	8,282,554	B2	10/2012	Makin et al.
7,235,592	B2	6/2007	Muratoglu	8,292,835	B1	10/2012	Cimino
7,258,674	B2	8/2007	Cribbs	8,298,163	B1	10/2012	Cimino
7,273,459	B2	9/2007	Desilets	8,333,700	B1	12/2012	Barthe et al.
7,294,125	B2	11/2007	Phalen et al.	8,334,637	B2	12/2012	Crunkilton et al.
7,297,117	B2	11/2007	Trucco	8,337,407	B2	12/2012	Quistgaard et al.
7,303,555	B2	12/2007	Makin et al.	8,343,051	B2	1/2013	Desilets et al.
7,311,679	B2	12/2007	Desilets et al.	8,454,540	B2	1/2013	Eshel et al.
7,327,071	B2	2/2008	Nishiyama et al.	8,366,622	B2	2/2013	Slayton et al.

(56)

## References Cited

## U.S. PATENT DOCUMENTS

8,398,549 B2	3/2013	Palmeri et al.	9,533,174 B2	1/2017	Barthe et al.
8,409,097 B2	4/2013	Slayton et al.	9,533,175 B2	1/2017	Slayton et al.
8,425,435 B2	4/2013	Wing et al.	9,545,529 B2	1/2017	Britva et al.
8,388,535 B2	5/2013	Weng et al.	9,566,454 B2	2/2017	Barthe et al.
8,444,562 B2	5/2013	Barthe et al.	9,623,267 B2	4/2017	Ulric et al.
8,460,193 B2	6/2013	Barthe et al.	9,694,211 B2	7/2017	Barthe et al.
8,480,585 B2	7/2013	Slayton et al.	9,694,212 B2	7/2017	Barthe et al.
8,486,001 B2	7/2013	Weyant	9,700,340 B2	7/2017	Barthe et al.
8,506,486 B2	8/2013	Slayton et al.	9,707,412 B2	7/2017	Slayton et al.
8,512,250 B2	8/2013	Quistgaard et al.	9,710,607 B2	7/2017	Ramdas et al.
8,523,775 B2	9/2013	Barthe et al.	9,713,731 B2	7/2017	Slayton et al.
8,523,849 B2	9/2013	Liu et al.	9,802,063 B2	10/2017	Barthe et al.
8,535,228 B2	9/2013	Slayton et al.	9,827,449 B2	11/2017	Barthe et al.
8,570,837 B2	10/2013	Toda et al.	9,827,450 B2	11/2017	Slayton et al.
8,573,392 B2	11/2013	Bennett et al.	9,833,639 B2	12/2017	Slayton et al.
8,583,211 B2	11/2013	Salomir et al.	9,833,640 B2	12/2017	Barthe et al.
8,585,618 B2	11/2013	Hunziker et al.	9,895,560 B2	2/2018	Barthe et al.
8,604,672 B2	12/2013	Toda et al.	9,907,535 B2	3/2018	Barthe et al.
8,622,937 B2	1/2014	Weng et al.	9,919,167 B2	3/2018	Domankevitz
8,636,665 B2	1/2014	Slayton et al.	9,974,982 B2	5/2018	Slayton et al.
8,641,622 B2	2/2014	Barthe et al.	1,001,072 A1	7/2018	Slayton et al.
8,663,112 B2	3/2014	Slayton et al.	1,004,618 A1	8/2018	Barthe et al.
8,672,848 B2	3/2014	Slayton et al.	1,023,889 A1	3/2019	Slayton et al.
8,690,778 B2	4/2014	Slayton et al.	1,024,545 A1	4/2019	Slayton et al.
8,690,779 B2	4/2014	Slayton et al.	1,025,208 A1	4/2019	Barthe et al.
8,690,780 B2	4/2014	Slayton et al.	1,026,555 A1	4/2019	Barthe et al.
8,708,935 B2	4/2014	Barthe et al.	1,032,828 A1	6/2019	Barthe et al.
8,715,186 B2	5/2014	Slayton et al.	2001/0009997 A1	7/2001	Pope
8,726,781 B2	5/2014	Eckhoff et al.	2001/0009999 A1	7/2001	Kaufman et al.
8,728,071 B2	5/2014	Lischinsky et al.	2001/0014780 A1	8/2001	Martin
8,753,295 B2	6/2014	Thierman	2001/0014819 A1	8/2001	Ingle
8,758,253 B2	6/2014	Sano et al.	2001/0031922 A1	10/2001	Weng
8,836,203 B2	9/2014	Nobles et al.	2001/0039380 A1	11/2001	Larson et al.
8,857,438 B2	10/2014	Barthe et al.	2001/0041880 A1	11/2001	Brisken
8,858,471 B2	10/2014	Barthe et al.	2002/0000763 A1	1/2002	Jones
8,915,853 B2	12/2014	Barthe et al.	2002/0002345 A1	1/2002	Marlinghaus
8,915,854 B2	12/2014	Slayton et al.	2002/0040199 A1	4/2002	Klopotek
8,915,870 B2	12/2014	Barthe et al.	2002/0040442 A1	4/2002	Ishidera
8,920,320 B2	12/2014	Stecco et al.	2002/0055702 A1	5/2002	Atala
8,920,324 B2	12/2014	Slayton et al.	2002/0062077 A1	5/2002	Emmenegger
8,926,533 B2	1/2015	Bockenstedt et al.	2002/0062142 A1	5/2002	Knowlton
8,932,224 B2	1/2015	Barthe et al.	2002/0072691 A1	6/2002	Thompson et al.
8,932,238 B2	1/2015	Wing et al.	2002/0082528 A1	6/2002	Friedman
8,968,205 B2	3/2015	Zeng et al.	2002/0082529 A1	6/2002	Suorsa et al.
9,011,336 B2	4/2015	Slayton et al.	2002/0082589 A1	6/2002	Friedman
9,039,617 B2	5/2015	Slayton et al.	2002/0087080 A1	7/2002	Slayton
9,039,619 B2	5/2015	Barthe et al.	2002/0095143 A1	7/2002	Key
9,050,116 B2	6/2015	Homer	2002/0099094 A1	7/2002	Anderson
9,095,697 B2	8/2015	Barthe et al.	2002/0115917 A1	8/2002	Honda et al.
9,107,798 B2	8/2015	Azhari et al.	2002/0128639 A1	8/2002	Pless et al.
9,114,247 B2	8/2015	Barthe et al.	2002/0128648 A1	9/2002	Weber
9,180,314 B2	11/2015	Desilets et al.	2002/0143252 A1	10/2002	Dunne et al.
9,216,276 B2	12/2015	Slayton et al.	2002/0156400 A1	10/2002	Babaev
9,220,915 B2	12/2015	Liu et al.	2002/0161357 A1	10/2002	Anderson
9,272,162 B2	3/2016	Slayton et al.	2002/0165529 A1	11/2002	Danek
9,283,409 B2	3/2016	Slayton et al.	2002/0168049 A1	11/2002	Schriever
9,283,410 B2	3/2016	Slayton et al.	2002/0169394 A1	11/2002	Eppstein et al.
9,295,607 B2	3/2016	Rosenberg	2002/0169442 A1	11/2002	Neev
9,308,390 B2	4/2016	Youngquist	2002/0173721 A1	11/2002	Grunwald et al.
9,308,391 B2	4/2016	Liu et al.	2002/0193784 A1	12/2002	McHale et al.
9,314,650 B2	4/2016	Rosenberg et al.	2002/0193831 A1	12/2002	Smith
9,320,537 B2	4/2016	Slayton et al.	2003/0009153 A1	1/2003	Brisken et al.
9,345,910 B2	5/2016	Slayton et al.	2003/0014039 A1	1/2003	Barzell et al.
9,421,029 B2	8/2016	Barthe et al.	2003/0018255 A1	1/2003	Martin
9,427,600 B2	8/2016	Barthe et al.	2003/0018270 A1	1/2003	Makin et al.
9,427,601 B2	8/2016	Barthe et al.	2003/0023283 A1	1/2003	McDaniel
9,433,803 B2	9/2016	Lin et al.	2003/0028111 A1	2/2003	Vaezy et al.
9,440,093 B2	9/2016	Homer	2003/0028113 A1	2/2003	Gilbert et al.
9,440,096 B2	9/2016	Barthe et al.	2003/0032900 A1	2/2003	Ella
9,492,645 B2	11/2016	Zhou et al.	2003/0036706 A1	2/2003	Slayton et al.
9,492,686 B2	11/2016	Da Silva	2003/0040739 A1	2/2003	Koop
9,498,651 B2	11/2016	Sapozhnikov et al.	2003/0050678 A1	3/2003	Sierra
9,510,802 B2	12/2016	Barthe et al.	2003/0055308 A1	3/2003	Friemel et al.
9,522,290 B2	12/2016	Slayton et al.	2003/0055417 A1	3/2003	Truckai et al.
9,532,832 B2	1/2017	Ron Edoute et al.	2003/0060736 A1	3/2003	Martin et al.
			2003/0065313 A1	4/2003	Koop
			2003/0066708 A1	4/2003	Allison et al.
			2003/0073907 A1	4/2003	Taylor
			2003/0074023 A1	4/2003	Kaplan

(56)

## References Cited

## U.S. PATENT DOCUMENTS

2003/0083536	A1	5/2003	Eshel	2005/0074407	A1	4/2005	Smith
2003/0092988	A1	5/2003	Makin	2005/0080469	A1	4/2005	Larson
2003/0097071	A1	5/2003	Halmann et al.	2005/0085731	A1	4/2005	Miller et al.
2003/0099383	A1	5/2003	Lefebvre	2005/0091770	A1	5/2005	Mourad et al.
2003/0125629	A1	7/2003	Ustuner	2005/0096542	A1	5/2005	Weng et al.
2003/0135135	A1	7/2003	Miwa et al.	2005/0104690	A1	5/2005	Larson et al.
2003/0139790	A1	7/2003	Ingle et al.	2005/0113689	A1	5/2005	Gritzky
2003/0149366	A1	8/2003	Stringer et al.	2005/0131302	A1	6/2005	Poland
2003/0153961	A1	8/2003	Babaev	2005/0137656	A1	6/2005	Malak
2003/0171678	A1	9/2003	Batten et al.	2005/0143677	A1	6/2005	Young et al.
2003/0171701	A1	9/2003	Babaev	2005/0154313	A1	7/2005	Desilets
2003/0176790	A1	9/2003	Slayton	2005/0154314	A1	7/2005	Quistgaard
2003/0191396	A1	10/2003	Sanghvi	2005/0154332	A1	7/2005	Zanelli
2003/0199794	A1	10/2003	Sakurai et al.	2005/0154431	A1	7/2005	Quistgaard
2003/0200481	A1	10/2003	Stanley	2005/0187495	A1	8/2005	Quistgaard
2003/0212129	A1	11/2003	Liu et al.	2005/0191252	A1	9/2005	Mitsui
2003/0212351	A1	11/2003	Hissong	2005/0193451	A1	9/2005	Quistgaard
2003/0212393	A1	11/2003	Knowlton	2005/0193820	A1	9/2005	Sheljaskow et al.
2003/0216648	A1	11/2003	Lizzi et al.	2005/0197681	A1	9/2005	Barolet et al.
2003/0216795	A1	11/2003	Harth	2005/0228281	A1	10/2005	Nefos
2003/0220536	A1	11/2003	Hissong	2005/0240127	A1	10/2005	Seip et al.
2003/0220585	A1	11/2003	Hissong	2005/0240170	A1	10/2005	Zhang et al.
2003/0229331	A1	12/2003	Brisken et al.	2005/0251120	A1	11/2005	Anderson et al.
2003/0233085	A1	12/2003	Giammarusti	2005/0251125	A1	11/2005	Pless et al.
2003/0236487	A1	12/2003	Knowlton	2005/0256406	A1	11/2005	Barthe
2004/0000316	A1	1/2004	Knowlton	2005/0261584	A1	11/2005	Eshel
2004/0001809	A1	1/2004	Brisken	2005/0261585	A1	11/2005	Makin et al.
2004/0002658	A1	1/2004	Marian, Jr.	2005/0267454	A1	12/2005	Hissong
2004/0002705	A1	1/2004	Knowlton	2005/0288748	A1	12/2005	Li et al.
2004/0010222	A1	1/2004	Nunomura et al.	2006/0004306	A1	1/2006	Altshuler
2004/0015079	A1	1/2004	Berger et al.	2006/0020260	A1	1/2006	Dover et al.
2004/0015106	A1	1/2004	Coleman	2006/0025756	A1	2/2006	Francischelli
2004/0030227	A1	2/2004	Littrup	2006/0042201	A1	3/2006	Curry
2004/0030268	A1	2/2004	Weng et al.	2006/0058664	A1	3/2006	Barthe
2004/0039312	A1	2/2004	Hillstead	2006/0058671	A1	3/2006	Vitek et al.
2004/0039418	A1	2/2004	Elstrom	2006/0058707	A1	3/2006	Barthe
2004/0041563	A1	3/2004	Lewin et al.	2006/0058712	A1	3/2006	Altshuler et al.
2004/0041880	A1	3/2004	Ikedo et al.	2006/0074309	A1	4/2006	Bonnefous
2004/0042168	A1	3/2004	Yang et al.	2006/0074313	A1	4/2006	Slayton et al.
2004/0044375	A1	3/2004	Diederich et al.	2006/0074314	A1	4/2006	Slayton
2004/0049134	A1	3/2004	Tosaya et al.	2006/0074355	A1*	4/2006	Slayton ..... A61H 23/0245
2004/0049734	A1	3/2004	Tosaya et al.				601/2
2004/0059266	A1	3/2004	Fry	2006/0079816	A1	4/2006	Barthe
2004/0068186	A1	4/2004	Ishida et al.	2006/0079868	A1	4/2006	Makin
2004/0073079	A1	4/2004	Altshuler et al.	2006/0084891	A1	4/2006	Barthe
2004/0073113	A1	4/2004	Salgo	2006/0089632	A1	4/2006	Barthe
2004/0073115	A1	4/2004	Horzewski et al.	2006/0089688	A1	4/2006	Panescu
2004/0073116	A1	4/2004	Smith	2006/0094988	A1	5/2006	Tosaya
2004/0073204	A1	4/2004	Ryan et al.	2006/0111744	A1	5/2006	Makin
2004/0077977	A1	4/2004	Ella et al.	2006/0116583	A1	6/2006	Ogasawara et al.
2004/0082857	A1	4/2004	Schonenberger	2006/0116671	A1	6/2006	Slayton
2004/0082859	A1	4/2004	Schaer	2006/0122508	A1	6/2006	Slayton
2004/0102697	A1	5/2004	Evron	2006/0122509	A1	6/2006	Desilets
2004/0105559	A1	6/2004	Aylward et al.	2006/0161062	A1	7/2006	Arditi et al.
2004/0106867	A1	6/2004	Eshel et al.	2006/0184069	A1	8/2006	Vaitekunas
2004/0122323	A1	6/2004	Vortman et al.	2006/0184071	A1	8/2006	Klopotek
2004/0122493	A1	6/2004	Ishibashi et al.	2006/0189972	A1	8/2006	Grossman
2004/0143297	A1	7/2004	Ramsey	2006/0206105	A1	9/2006	Chopra
2004/0152982	A1	8/2004	Hwang et al.	2006/0224090	A1	10/2006	Ostrovsky et al.
2004/0158150	A1	8/2004	Rabiner et al.	2006/0229514	A1	10/2006	Wiener
2004/0186535	A1	9/2004	Knowlton	2006/0241440	A1	10/2006	Eshel
2004/0189155	A1	9/2004	Funakubo	2006/0241442	A1	10/2006	Barthe
2004/0206365	A1	10/2004	Knowlton	2006/0241470	A1	10/2006	Novak et al.
2004/0210214	A1	10/2004	Knowlton	2006/0241576	A1	10/2006	Diederich et al.
2004/0217675	A1	11/2004	Desilets	2006/0250046	A1	11/2006	Koizumi et al.
2004/0249318	A1	12/2004	Tanaka	2006/0282691	A1	12/2006	Barthe
2004/0254620	A1	12/2004	Lacoste	2006/0291710	A1	12/2006	Wang et al.
2004/0267252	A1	12/2004	Washington et al.	2007/0016039	A1	1/2007	Vortman et al.
2005/0033201	A1	2/2005	Takahashi	2007/0032784	A1	2/2007	Gliklich et al.
2005/0033316	A1	2/2005	Kertz	2007/0035201	A1	2/2007	Desilets
2005/0038340	A1	2/2005	Vaezy et al.	2007/0055154	A1*	3/2007	Torbati ..... A61H 23/0245
2005/0055018	A1	3/2005	Kreindel				600/439
2005/0055073	A1	3/2005	Weber	2007/0055155	A1	3/2007	Owen et al.
2005/0061834	A1	3/2005	Garcia et al.	2007/0055156	A1	3/2007	Desilets et al.
2005/0070961	A1	3/2005	Maki	2007/0065420	A1	3/2007	Johnson
				2007/0083120	A1	4/2007	Cain et al.
				2007/0087060	A1	4/2007	Dietrich
				2007/0088245	A1	4/2007	Babaev et al.
				2007/0088346	A1	4/2007	Mirizzi et al.

(56)

## References Cited

## U.S. PATENT DOCUMENTS

2010/0049178	A1	2/2010	Deem et al.
2010/0056925	A1	3/2010	Zhang et al.
2010/0100014	A1	4/2010	Eshel et al.
2010/0113983	A1	5/2010	Heckerman et al.
2010/0130891	A1	5/2010	Taggart et al.
2010/0160782	A1	6/2010	Slayton et al.
2010/0160837	A1	6/2010	Hunziker et al.
2010/0168576	A1	7/2010	Poland et al.
2010/0191120	A1	7/2010	Kraus et al.
2010/0241035	A1	9/2010	Barthe et al.
2010/0249602	A1	9/2010	Buckley et al.
2010/0249669	A1	9/2010	Ulric et al.
2010/0256489	A1	10/2010	Pedersen et al.
2010/0274161	A1	10/2010	Azhari et al.
2010/0280420	A1	11/2010	Barthe et al.
2010/0286518	A1	11/2010	Lee et al.
2010/0312150	A1	12/2010	Douglas et al.
2011/0040171	A1	2/2011	Foley et al.
2011/0040190	A1	2/2011	Jahnke et al.
2011/0040213	A1	2/2011	Dietz et al.
2011/0040214	A1	2/2011	Foley et al.
2011/0066084	A1	3/2011	Desilets et al.
2011/0077514	A1	3/2011	Ulric et al.
2011/0087099	A1	4/2011	Eshel et al.
2011/0087255	A1	4/2011	McCormack et al.
2011/0112405	A1	5/2011	Barthe et al.
2011/0144490	A1	6/2011	Davis et al.
2011/0178444	A1	7/2011	Slayton et al.
2011/0178541	A1	7/2011	Azhari
2011/0190745	A1	8/2011	Uebelhoer et al.
2011/0201976	A1	8/2011	Sanghvi et al.
2011/0251524	A1	10/2011	Azhari et al.
2011/0251527	A1	10/2011	Kushculey et al.
2011/0270137	A1	11/2011	Goren et al.
2011/0319793	A1	12/2011	Henrik et al.
2011/0319794	A1	12/2011	Gertner
2012/0004549	A1	1/2012	Barthe et al.
2012/0016239	A1	1/2012	Barthe et al.
2012/0029353	A1	2/2012	Slayton et al.
2012/0035473	A1	2/2012	Sanghvi et al.
2012/0035475	A1	2/2012	Barthe et al.
2012/0035476	A1	2/2012	Barthe et al.
2012/0046547	A1	2/2012	Barthe et al.
2012/0053458	A1	3/2012	Barthe et al.
2012/0059288	A1	3/2012	Barthe et al.
2012/0111339	A1	5/2012	Barthe et al.
2012/0123304	A1	5/2012	Rybyanets et al.
2012/0136280	A1	5/2012	Rosenberg et al.
2012/0136282	A1	5/2012	Rosenberg et al.
2012/0143056	A1	6/2012	Slayton et al.
2012/0143100	A1	6/2012	Jeong et al.
2012/0165668	A1	6/2012	Slayton et al.
2012/0165848	A1	6/2012	Slayton et al.
2012/0191019	A1	7/2012	Desilets et al.
2012/0191020	A1	7/2012	Vitek et al.
2012/0197120	A1	8/2012	Makin et al.
2012/0197121	A1	8/2012	Slayton et al.
2012/0209150	A1	8/2012	Zeng et al.
2012/0215105	A1	8/2012	Slayton et al.
2012/0271202	A1	10/2012	Wisdom
2012/0271294	A1	10/2012	Barthe et al.
2012/0277639	A1	11/2012	Pollock et al.
2012/0296240	A1	11/2012	Azhari et al.
2012/0302883	A1	11/2012	Kong et al.
2012/0316426	A1	12/2012	Foley et al.
2012/0330197	A1	12/2012	Makin et al.
2012/0330222	A1	12/2012	Makin et al.
2012/0330223	A1	12/2012	Makin et al.
2012/0330283	A1	12/2012	Hyde et al.
2012/0330284	A1	12/2012	Hyde et al.
2013/0012755	A1	1/2013	Slayton
2013/0012816	A1	1/2013	Slayton et al.
2013/0012838	A1	1/2013	Jaeger et al.
2013/0012842	A1	1/2013	Barthe
2013/0018285	A1	1/2013	Park et al.
2013/0018286	A1	1/2013	Slayton et al.
2013/0046209	A1	2/2013	Slayton et al.
2013/0051178	A1	2/2013	Rybyanets
2013/0060170	A1	3/2013	Lee et al.
2007/0161902	A1	7/2007	Dan
2007/0166357	A1	7/2007	Shaffer et al.
2007/0167709	A1	7/2007	Slayton
2007/0208253	A1	9/2007	Slayton
2007/0219604	A1	9/2007	Yaroslaysky et al.
2007/0219605	A1	9/2007	Yaroslaysky et al.
2007/0238994	A1	10/2007	Stecco et al.
2007/0239075	A1	10/2007	Rosenberg
2007/0239077	A1	10/2007	Azhari et al.
2007/0239079	A1	10/2007	Manstein et al.
2007/0239142	A1	10/2007	Altshuler
2008/0015435	A1	1/2008	Cribbs et al.
2008/0027328	A1	1/2008	Klopotek
2008/0033458	A1	2/2008	McLean et al.
2008/0039724	A1	2/2008	Seip et al.
2008/0071255	A1	3/2008	Barthe
2008/0086054	A1	4/2008	Slayton
2008/0086056	A1	4/2008	Chang et al.
2008/0097214	A1	4/2008	Meyers et al.
2008/0097253	A1	4/2008	Pedersen et al.
2008/0114251	A1	5/2008	Weymer
2008/0139943	A1	6/2008	Deng et al.
2008/0139974	A1	6/2008	Da Silva
2008/0146970	A1	6/2008	Litman et al.
2008/0167556	A1	7/2008	Thompson
2008/0183077	A1	7/2008	Moreau-Gobard et al.
2008/0183110	A1	7/2008	Davenport et al.
2008/0188745	A1	8/2008	Chen et al.
2008/0194964	A1	8/2008	Randall et al.
2008/0195000	A1	8/2008	Spooner et al.
2008/0200810	A1	8/2008	Buchalter
2008/0200813	A1	8/2008	Quistgaard
2008/0214966	A1	9/2008	Slayton
2008/0214988	A1	9/2008	Altshuler et al.
2008/0221491	A1	9/2008	Slayton
2008/0223379	A1	9/2008	Stuker et al.
2008/0242991	A1	10/2008	Moon et al.
2008/0243035	A1	10/2008	Crunkilton
2008/0269608	A1	10/2008	Anderson et al.
2008/0275342	A1	11/2008	Barthe
2008/0281206	A1	11/2008	Bartlett et al.
2008/0281236	A1	11/2008	Eshel et al.
2008/0281237	A1	11/2008	Slayton
2008/0281255	A1	11/2008	Slayton
2008/0294073	A1	11/2008	Barthe
2008/0319356	A1	12/2008	Cain
2009/0005680	A1	1/2009	Jones et al.
2009/0012394	A1	1/2009	Hobelsberger et al.
2009/0043198	A1	2/2009	Milner et al.
2009/0043293	A1	2/2009	Pankratov et al.
2009/0048514	A1	2/2009	Azhari et al.
2009/0069677	A1	3/2009	Chen et al.
2009/0093737	A1	4/2009	Chomas et al.
2009/0156969	A1	6/2009	Santangelo
2009/0163807	A1	6/2009	Sliwa
2009/0171252	A1	7/2009	Bockenstedt et al.
2009/0177122	A1	7/2009	Peterson
2009/0177123	A1	7/2009	Peterson
2009/0182231	A1	7/2009	Barthe et al.
2009/0198157	A1	8/2009	Babaev et al.
2009/0216159	A1	8/2009	Slayton et al.
2009/0226424	A1	9/2009	Hsu
2009/0227910	A1	9/2009	Pedersen et al.
2009/0230823	A1	9/2009	Kushculey et al.
2009/0253988	A1	10/2009	Slayton et al.
2009/0281463	A1	11/2009	Chapelon et al.
2009/0312693	A1	12/2009	Thapliyal et al.
2009/0318909	A1	12/2009	Debenedictis et al.
2009/0326420	A1	12/2009	Mooney et al.
2010/0011236	A1	1/2010	Barthe et al.
2010/0022919	A1	1/2010	Peterson
2010/0022921	A1	1/2010	Seip et al.
2010/0022922	A1	1/2010	Barthe et al.
2010/0030076	A1	2/2010	Vortman et al.
2010/0042020	A1	2/2010	Ben-Ezra

(56)

## References Cited

## U.S. PATENT DOCUMENTS

2013/0066208 A1 3/2013 Barthe et al.  
 2013/0066237 A1 3/2013 Smotrich et al.  
 2013/0072826 A1 3/2013 Slayton et al.  
 2013/0073001 A1 3/2013 Campbell  
 2013/0096471 A1 4/2013 Slayton et al.  
 2013/0190659 A1 7/2013 Slayton et al.  
 2013/0211293 A1 8/2013 Auboiroux et al.  
 2013/0225994 A1 8/2013 Hsu et al.  
 2013/0268032 A1 10/2013 Neev  
 2013/0274603 A1 10/2013 Barthe et al.  
 2013/0281853 A1 10/2013 Slayton et al.  
 2013/0281891 A1 10/2013 Slayton et al.  
 2013/0296697 A1 11/2013 Slayton et al.  
 2013/0296700 A1 11/2013 Slayton et al.  
 2013/0296743 A1 11/2013 Lee et al.  
 2013/0303904 A1 11/2013 Barthe et al.  
 2013/0303905 A1 11/2013 Barthe et al.  
 2013/0310714 A1 11/2013 Eshel et al.  
 2013/0310863 A1 11/2013 Makin et al.  
 2013/0345562 A1 12/2013 Barthe et al.  
 2014/0024974 A1 1/2014 Slayton et al.  
 2014/0050054 A1 2/2014 Toda et al.  
 2014/0081300 A1 3/2014 Melodelima et al.  
 2014/0082907 A1 3/2014 Barthe et al.  
 2014/0117814 A1 5/2014 Toda et al.  
 2014/0142430 A1 5/2014 Slayton et al.  
 2014/0148834 A1 5/2014 Barthe et al.  
 2014/0180174 A1 6/2014 Slayton et al.  
 2014/0187944 A1 7/2014 Slayton et al.  
 2014/0188015 A1 7/2014 Slayton et al.  
 2014/0188145 A1 7/2014 Slayton et al.  
 2014/0194723 A1 7/2014 Herzog et al.  
 2014/0208856 A1 7/2014 Schmid  
 2014/0221823 A1 8/2014 Keogh et al.  
 2014/0236049 A1 8/2014 Barthe et al.  
 2014/0236061 A1 8/2014 Lee et al.  
 2014/0243713 A1 8/2014 Slayton et al.  
 2014/0257145 A1 9/2014 Emery  
 2014/0276055 A1 9/2014 Barthe et al.  
 2015/0000674 A1 1/2015 Barthe et al.  
 2015/0025420 A1 1/2015 Slayton et al.  
 2015/0080723 A1 3/2015 Barthe et al.  
 2015/0080771 A1 3/2015 Barthe et al.  
 2015/0080874 A1 3/2015 Slayton et al.  
 2015/0088182 A1 3/2015 Slayton et al.  
 2015/0141734 A1 5/2015 Chapelon et al.  
 2015/0164734 A1 6/2015 Slayton et al.  
 2015/0165238 A1 6/2015 Slayton et al.  
 2015/0165243 A1 6/2015 Slayton et al.  
 2015/0174388 A1 6/2015 Slayton  
 2015/0202468 A1 7/2015 Slayton et al.  
 2015/0217141 A1 8/2015 Barthe et al.  
 2015/0238258 A1 8/2015 Palero et al.  
 2015/0321026 A1 11/2015 Branson et al.  
 2015/0360058 A1 12/2015 Barthe et al.  
 2015/0374333 A1 12/2015 Barthe et al.  
 2015/0375014 A1 12/2015 Slayton et al.  
 2016/0001097 A1 1/2016 Cho et al.  
 2016/0016015 A1 1/2016 Slayton et al.  
 2016/0027994 A1 1/2016 Toda et al.  
 2016/0151618 A1 6/2016 Powers et al.  
 2016/0175619 A1 6/2016 Lee et al.  
 2016/0206335 A1 7/2016 Slayton  
 2016/0206341 A1 7/2016 Slayton  
 2016/0256675 A1 9/2016 Slayton  
 2016/0296769 A1 10/2016 Barthe et al.  
 2016/0361571 A1 12/2016 Bernabei  
 2016/0361572 A1 12/2016 Slayton  
 2017/0028227 A1 2/2017 Emery et al.  
 2017/0043190 A1 2/2017 Barthe et al.  
 2017/0050019 A1 2/2017 Ron Edoute et al.  
 2017/0080257 A1 3/2017 Paunescu et al.  
 2017/0100585 A1 4/2017 Hall et al.  
 2017/0136263 A1 5/2017 Reil  
 2017/0209201 A1 7/2017 Slayton et al.

2017/0304654 A1 10/2017 Blanche et al.  
 2018/0001113 A1 1/2018 Streeter  
 2018/0015308 A1 1/2018 Reed et al.  
 2018/0043147 A1 2/2018 Slayton  
 2018/0099162 A1 4/2018 Bernabei  
 2018/0099163 A1 4/2018 Bernabei  
 2018/0272156 A1 9/2018 Slayton et al.  
 2018/0272157 A1 9/2018 Barthe et al.  
 2018/0272158 A1 9/2018 Barthe et al.  
 2018/0272159 A1 9/2018 Slayton et al.

## FOREIGN PATENT DOCUMENTS

DE 4029175 3/1992  
 DE 10140064 3/2003  
 DE 10219297 11/2003  
 DE 10219217 12/2004  
 DE 20314479 12/2004  
 EP 0142215 5/1984  
 EP 0344773 12/1989  
 EP 1479412 11/1991  
 EP 0473553 4/1992  
 EP 670147 2/1995  
 EP 0661029 7/1995  
 EP 724894 2/1996  
 EP 763371 11/1996  
 EP 1044038 10/2000  
 EP 1050322 11/2000  
 EP 1234566 8/2002  
 EP 1262160 12/2002  
 EP 0659387 4/2003  
 EP 1374944 1/2004  
 EP 1028660 1/2008  
 EP 1874241 1/2008  
 EP 1362223 5/2008  
 EP 1750804 7/2008  
 EP 1283690 11/2008  
 EP 1811901 4/2009  
 EP 1785164 8/2009  
 EP 2230904 9/2010  
 EP 1501331 6/2011  
 EP 2066405 11/2011  
 EP 2474050 7/2012  
 EP 2709726 11/2015  
 EP 1538980 1/2017  
 EP 2897547 11/2017  
 FR 2532851 9/1983  
 FR 2685872 1/1992  
 FR 2672486 8/1992  
 FR 2703254 3/1994  
 GB 2113099 8/1983  
 IL 102516 1/1996  
 IL 112369 8/1999  
 IL 120079 3/2001  
 JP 63036171 2/1988  
 JP 03048299 3/1991  
 JP 3123559 5/1991  
 JP 03136642 6/1991  
 JP 4089058 3/1992  
 JP 04150847 5/1992  
 JP 7080087 3/1995  
 JP 07505793 6/1995  
 JP 7184907 7/1995  
 JP 7222782 8/1995  
 JP 09047458 2/1997  
 JP 9108288 4/1997  
 JP 9503926 4/1997  
 JP 11123226 5/1999  
 JP 11505440 5/1999  
 JP 11506636 6/1999  
 JP 10248850 9/1999  
 JP 2000126310 5/2000  
 JP 2000166940 6/2000  
 JP 2000233009 8/2000  
 JP 2001170068 6/2001  
 JP 2002505596 2/2002  
 JP 2002078764 3/2002  
 JP 2002515786 5/2002  
 JP 2002521118 7/2002

(56)

## References Cited

## FOREIGN PATENT DOCUMENTS

JP	2002537939	11/2002
JP	2003050298	7/2003
JP	2003204982	7/2003
JP	2004-504898	2/2004
JP	2004-507280	3/2004
JP	2004-509671	4/2004
JP	2004-512856	4/2004
JP	2004147719	5/2004
JP	2005503388	2/2005
JP	2005527336	9/2005
JP	2005323213	11/2005
JP	2006520247	9/2006
JP	2008515559	5/2008
JP	2009518126	5/2009
JP	2010517695	5/2010
KR	1020010024871	3/2001
KR	100400870	10/2003
KR	20060121267	11/2006
KR	1020060113930	11/2006
KR	1020070065332	6/2007
KR	1020070070161	7/2007
KR	1020070098856	10/2007
KR	1020070104878	10/2007
KR	1020070114105	11/2007
KR	1020000059516	4/2012
KR	10-2013-0124598	11/2013
KR	10-1365946	2/2014
TW	386883	9/2000
TW	201208734 A	3/2012
WO	WO9312742	7/1993
WO	WO9524159	9/1995
WO	WO9625888	8/1996
WO	WO9634568	11/1996
WO	WO9639079	12/1996
WO	WO9735518	10/1997
WO	WO9832379	7/1998
WO	WO9852465	11/1998
WO	WO9933520	7/1999
WO	WO9939677	8/1999
WO	WO9949788	10/1999
WO	WO200006032	2/2000
WO	WO0015300	3/2000
WO	WO0021612	4/2000
WO	WO0053113	9/2000
WO	WO0128623	4/2001
WO	WO0104550	6/2001
WO	WO0182777	11/2001
WO	WO0182778	11/2001
WO	WO0187161	11/2001
WO	WO01080709	11/2001
WO	WO2001087161	11/2001
WO	WO0209812	2/2002
WO	WO0209813	2/2002
WO	WO02015768	2/2002
WO	WO0224050	3/2002
WO	WO2002054018	7/2002
WO	WO02092168	11/2002
WO	WO03053266	7/2003
WO	WO03065347	8/2003
WO	WO03070105	8/2003
WO	WO03077833	9/2003
WO	WO03086215	10/2003
WO	WO03096883	11/2003
WO	WO03099177	12/2003
WO	WO03099382	12/2003
WO	WO03101530	12/2003
WO	WO2004000116	12/2003
WO	WO2004080147	9/2004
WO	WO2004110558	12/2004
WO	WO2005/011804	2/2005
WO	WO2005065408	7/2005
WO	WO2005065409	7/2005
WO	WO2005090978	9/2005
WO	WO2005113068	12/2005
WO	WO2006/042163	4/2006

WO	WO2006036870	4/2006
WO	WO2006042168	4/2006
WO	WO2006042201	4/2006
WO	WO2006065671	6/2006
WO	WO2006082573	8/2006
WO	WO2006104568	10/2006
WO	WO2007067563	6/2007
WO	WO2008036479	3/2008
WO	WO2008036622	3/2008
WO	WO2008144274	11/2008
WO	WO2009013729	1/2009
WO	WO2009149390	10/2009
WO	WO2012134645	10/2012
WO	WO2013048912	4/2013
WO	WO2013178830	12/2013
WO	WO2014045216	3/2014
WO	WO2014055708	4/2014
WO	WO2014057388	4/2014
WO	WO2014127091	8/2014
WO	WO2015160708	10/2015
WO	WO2016054155	4/2016
WO	WO2017127328	7/2017
WO	WO2017149506	9/2017
WO	WO2017165595	9/2017
WO	WO2017212489	12/2017
WO	WO2018035012	2/2018
WO	WO 2019147596	8/2019

## OTHER PUBLICATIONS

- Alam, M., "The future of noninvasive procedural dermatology". *Semin Cutan Med Surg.* Mar. 2013; 32(1):59-61.
- Alam, M., et al., "Ultrasound tightening of facial and neck skin: a rater-blinded prospective cohort study". *J Am Acad Dermatol.* 2010. 62(2): p. 262-9.
- Alexiades-Armenakas, M., "Ultrasound Technologies for Dermatologic Techniques". *J Drugs Derm.* 2014. 12 (11): p. 1305.
- Alster, T.S., et al., "Noninvasive lifting of arm, thigh, and knee skin with transcutaneous intense focused ultrasound". *Dermatol Surg.* 2012. 38(5): p. 754-9.
- Alster, Tinas S., Tanzi, Elizabeth L., "Cellulite Treatment using a Novel Combination Radiofrequency, Infrared Light, and Mechanical Tissue Manipulation Device," *Journal of Cosmetic & Laser Therapy,* Jun. 2005, vol. 7, Issue 2, pp. 81-85.
- Arosarena, O., "Options and Challenges for Facial Rejuvenation in Patients With Higher Fitzpatrick Skin Phototypes". *JAMA Facial Plastic Surgery,* 2015.
- Arthur et al., "Non-invasive estimation of hyperthermia temperatures with ultrasound," *Int. J. Hyperthermia,* Sep. 2005, 21(6), pp. 589-600.
- Barthe et al., "Ultrasound therapy system and ablation results utilizing miniature imaging/therapy arrays." *Ultrasonics Symposium,* 2004 IEEE, Aug. 23, 2004, pp. 1792-1795, vol. 3.
- Bozec, Laurent et al., *Thermal Denaturation Studies of Collagen by Microthermal Analysis and Atomic Force Microscopy,* *Biophysical Journal,* vol. 101, pp. 228-236. (Jul. 2001).
- Brobst, R.W., et al., "Noninvasive Treatment of the Neck". *Facial Plast Surg Clin North Am,* 2014. 22(2): p. 191-202.
- Brobst, R.W., et al., "Ulthera: initial and six month results". *Facial Plast Surg Clin North Am,* 2012. 20(2): p. 163-76.
- Calderhead et al., "One Mechanism Behind LED Photo-Therapy for Wound Healing and Skin Rejuvenation: Key Role of the Mast Cell" *Laser Therapy* 17.3: 141-148 (2008).
- Casabona, G., et al., "Microfocused Ultrasound with Visualization and Calcium Hydroxylapatite for Improving Skin Laxity and Cellulite Appearance"; *Plast Reconstr Surg Glob Open.* Jul. 25, 2017;5(7):e1388, 8 pages.
- Casabona, G., et al., "Microfocused Ultrasound With Visualization and Fillers for Increased Neocollagenesis: Clinical and Histological Evaluation". *Dermatol Surg* 2014;40:S194-S198.
- Chan, N.P., et al., "Safety study of transcutaneous focused ultrasound for non-invasive skin tightening in Asians". *Lasers Surg Med,* 2011. 43(5): p. 366-75.

(56)

## References Cited

## OTHER PUBLICATIONS

- Chapelon et al., "Effects of Cavitation in the High Intensity Therapeutic Ultrasound", Ultrasonics Symposium—1357 (1991).
- Chapelon, et al., "Thresholds for Tissue Ablation by Focused Ultrasound" (1990).
- Chen, L. et al., "Effect of Blood Perfusion on the ablation of liver parenchyma with high intensity focused ultrasound," *Phys. Med. Biol.* 38:1661-1673; 1993b.
- Coon, Joshua et al., "Protein identification using sequential ion/ion reactions and tandem mass spectrometry" *Proceedings of the National Academy of Sciences of the USA*, vol. 102, No. 27, Jul. 27, 2005, pp. 9463-9468.
- Corry, Peter M., et al., "Human Cancer Treatment with Ultrasound", *IEEE Transactions on Sonics and Ultrasonics*, vol. SU-31, No. 5, Sep. 1984, pp. 444, 456.
- Damianou et al., "Application of the Thermal Dose Concept for Predicting the Necrosed Tissue Volume During Ultrasound Surgery," 1993 IEEE Ultrasound Symposium, pp. 1199-1202.
- Daum et al., Design and Evaluation of a Feedback Based Phased Array System for Ultrasound Surgery, *IEEE Transactions on Ultrasonics, Ferroelectrics, and Frequency Control*, vol. 45, No. 2, Mar. 1998, pp. 431-438.
- Davis, Brian J., et al., "An Acoustic Phase Shift Technique for the Non-Invasive Measurement of Temperature Changes in Tissues", 1985 Ultrasonics Symposium, pp. 921-924.
- Dayan, S.H., et al., "Prospective, Multi-Center, Pivotal Trial Evaluating the Safety and Effectiveness of Micro-Focused Ultrasound with Visualization (MFU-V) for Improvement in Lines and Wrinkles of the Décolletage". *Plast Reconstr Surg.* Oct. 2014; 134(4 Suppl 1):123-4.
- Decision of the Korean Intellectual Property Tribunal dated Jun. 28, 2013 regarding Korean Patent No. 10-1142108, which is related to the pending application and/or an application identified in the Table on pp. 1-4 of the Information Disclosure Statement herein (English translation, English translation certification, and Korean decision included).
- Delon Martin, C., et al., "Venous Thrombosis Generation by Means of High-Intensity Focused Ultrasound" *Ultrasound in Med. & Biol.*, vol. 21, No. 1, pp. 113-119 (1995).
- Dierickx, Christine C., "The Role of Deep Heating for Noninvasive Skin Rejuvenation" *Lasers in Surgery and Medicine* 38:799-807 (2006).
- Dobke, M.K., et al., "Tissue restructuring by energy-based surgical tools". *Clin Plast Surg.* 2012. 39(4): p. 399-408.
- Dong, Yuan-Lin et al., "Effect of Ibuprofen on the Inflammatory Response to Surgical Wounds" *The Journal of Trauma*, vol. 35, No. 3. (1993).
- Dvivedi, Sanjay, et al. "Effect of Ibuprofen and diclofenac sodium on experimental wound healing" *Indian Journal of Experimental Biology*, vol. 35, pp. 1243-1245. (Nov. 1997).
- Fabi, S.G., "Microfocused Ultrasound With Visualization for Skin Tightening and Lifting: My Experience and a Review of the Literature". *Dermatol Surg.* Dec. 2014; 40 Suppl 12:S164-7.
- Fabi, S.G., "Noninvasive skin tightening: focus on new ultrasound techniques". *Clin Cosmet Investig Dermatol.* Feb. 5, 2015; 8:47-52.
- Fabi, S.G., et al., "A prospective multicenter pilot study of the safety and efficacy of microfocused ultrasound with visualization for improving lines and wrinkles of the décolleté". *Dermatol Surg.* Mar. 2015; 41(3):327-35.
- Fabi, S.G., et al., "Evaluation of microfocused ultrasound with visualization for lifting, tightening, and wrinkle reduction of the décolletage". *J Am Acad Dermatol.* 2013. 69(6): p. 965-71.
- Fabi, S.G., et al., "Future directions in cutaneous laser surgery". *Dermatol Clin.* 2014. 32(1): p. 61-9.
- Fabi, S.G., et al., "Retrospective Evaluation of Micro-focused Ultrasound for Lifting and Tightening the Face and Neck". *Dermatol Surg.* 2014.
- Friedmann D.P., "Comments on evaluation of microfocused ultrasound system for improving skin laxity and tightening in the lower face". *Aesthet Surg J.* Mar. 2015;35(3):NP81-2.
- Friedmann, D.P., et al., "Combination of intense pulsed light, Sculptra, and Ultherapy for treatment of the aging face". *J Cosmet Dermatol.* 2014. 13(2): p. 109-18.
- Fry, W.J. et al., "Production of Focal Destructive Lesions in the Central Nervous System with Ultrasound." *J. Neurosurg.*, 11:471-478; 1954.
- Fujimoto, et al., "A New Cavitation Suppression Technique for Local Ablation Using High-Intensity Focused Ultrasound" *Ultrasonics Symposium—1629* (1995).
- Gliklich et al., Clinical Pilot Study of Intense Ultrasound therapy to Deep Dermal Facial Skin and Subcutaneous Tissues, *Arch Facial Plastic Surgery*, Mar. 1, 2007, vol. 9, No. 1.
- Gold, M.H., et al., "Use of Micro-Focused Ultrasound with Visualization to Lift and Tighten Lax Knee Skin". *J Cosmet Laser Ther.* 2014: p. 1-15.
- Goldberg, D.J., et al., "Safety and Efficacy of Microfocused Ultrasound to Lift, Tighten, and Smooth the Buttocks". *Dermatol Surg.* 2014; 40:1113-1117.
- Greene, R.M., et al., "Skin tightening technologies". *Facial Plast Surg.* Feb. 2014; 30(1):62-7.
- Greenhalgh, David G., "Wound healing and diabetes mellitus" *Clinics in Plastic Surgery* 30; 37-45. (2003).
- Guo, S. et al., "Factors Affecting Wound Healing" *Critical Reviews in Oral Biology & Medicine*, *J Dent Res* 89(3), pp. 219-229. (2010).
- Haar, G.R. et al., "Tissue Destruction with Focused Ultrasound in Vivo." *Eur. Urol.* 23 (suppl. 1):8-11; 1993.
- Hantash, Basil M. et al., "Bipolar Fractional Radiofrequency Treatment Induces Neoeostogenesis and Neocollagenesis" *Lasers in Surgery and Medicine* 41:1-9 (2009).
- Hantash, Basil M. et al., "In Vivo Histological Evaluation of a Novel Ablative Fractional Resurfacing Device" *Lasers in Surgery and Medicine* 39:96-107 (2007).
- Harris, M.O., "Safety of Microfocused Ultrasound With Visualization in Patients With Fitzpatrick Skin Phototypes III to VI". *JAMA Facial Plast. Surg.* 2015.
- Hart, et al., "Current Concepts in the Use of PLLA: Clinical Synergy Noted with Combined Use of Microfocused Ultrasound and Poly-L-Lactic Acid on the Face, Neck, and Décolletage". *Amer. Soc. Plast. Surg.* 2015. 136; 180-187S.
- Hassan et al., "Structure and Applications of Poly(vinyl alcohol) Hydrogels Produced by Conventional Crosslinking or by Freezing/Thawing Methods," *advanced in Polymer Science*, 2000, pp. 37-65, vol. 153.
- Hassan et al., "Structure and Morphology of Freeze/Thawed PVA Hydrogels," *Macromolecules*, Mar. 11, 2000, pp. 2472-2479, vol. 33, No. 7.
- Hexsel et al., "A Validated Photonumeric Cellulite Severity Scale"; *J Eur Acad Dermatol Venereol.* May 2009; 23(5):523-8, 6 pages.
- Hitchcock, T.M. et al., "Review of the safety profile for microfocused ultrasound with Visualization". *Journal of Cosmetic Dermatology*, 13, 329-335. (2014).
- Husseini et al., "The Role of Cavitation in Acoustically Activated Drug Delivery," *J. Control Release*, Oct. 3, 2005, pp. 253-261, vol. 107(2).
- Husseini et al. "Investigating the mechanism of acoustically activated uptake of drugs from Pluronic micelles," *BMD Cancer* 2002, 2:20k, Aug. 30, 2002, pp. 1-6.
- Hynynen et al., Temperature Distributions During Local Ultrasound Induced Hyperthermia In Vivo, *Ultrasonics Symposium—745* (1982).
- Jeffers et al., "Evaluation of the Effect of Cavitation Activity on Drug-Ultrasound Synergisms," 1993 IEEE Ultrasonics Symposium, pp. 925-928.
- Jenne, J., et al., "Temperature Mapping for High Energy US-Therapy", 1994 Ultrasonics Symposium, pp. 1879-1882.
- Jeong, K.H., et al., "Neurologic complication associated with intense focused ultrasound". *J Cosmet Laser Ther.* 2013.
- Johnson, S.A., et al., "Non-Intrusive Measurement of Microwave and Ultrasound-Induced Hyperthermia by Acoustic Temperature Tomography", *Ultrasonics Symposium Proceedings*, pp. 977-982. (1977).
- Kim, H.J., et al., "Coagulation and ablation patterns of high-intensity focused ultrasound on a tissue mimicking phantom and cadaveric skin". *Laser Med Sci.* Sep. 4, 2015.

(56)

## References Cited

## OTHER PUBLICATIONS

- Kornstein, A.N., "Ulthera for silicone lip correction". *Plast Reconstr Surg*, 2012. 129(6): p. 1014e-1015e.
- Kornstein, A.N., "Ultherapy shrinks nasal skin after rhinoplasty following failure of conservative measures". *Plast Reconstr Surg*, 2013. 131(4): p. 664e-6e.
- Krischak, G.D., et al., "The effects of non-steroidal anti-inflammatory drug application on incisional wound healing in rats" *Journal of Wound Care*, vol. 6, No. 2, (Feb. 2007).
- Laubach, H.J., et al., "Confined Thermal Damage with Intense Ultrasound (IUS)" [abstr.] *American Society for Laser Medicine and Surgery Abstracts*, p. 15 #43 (Apr. 2006).
- Laubach, H.J., et al., "Intense focused ultrasound: evaluation of a new treatment modality for precise microcoagulation within the skin". *Dermatol Surg*, 2008. 34(5): p. 727-34.
- Lee, H.J., et al., "The efficacy and safety of intense focused ultrasound in the treatment of enlarged facial pores in Asian skin". *J Dermatolog Treat*, 2014.
- Lee, H.S., et al., "Multiple Pass Ultrasound Tightening of Skin Laxity of the Lower Face and Neck". *Dermatol Surg*, 2011.
- Lin, Sung-Jan, et al., "Monitoring the thermally induced structural transitions of collagen by use of second-harmonic generation microscopy" *Optics Letters*, vol. 30, No. 6, (Mar. 15, 2005).
- MacGregor J.L., et al., "Microfocused Ultrasound for Skin Tightening". *Semin Cutan Med Surg* 32:18-25. (2013).
- Madersbacher, S. et al., "Tissue Ablation in Benign Prostatic Hyperplasia with High Intensity Focused Ultrasound," *Dur. Urol.*, 23 (suppl. 1):39-43; 1993.
- Makin et al, "B-Scan Imaging and Thermal Lesion Monitoring Using Miniaturized Dual-Functionality Ultrasound Arrays," *Ultrasonics Symposium*, 2004 IEEE, Aug. 23, 2004, pp. 1788-1791, vol. 3.
- Makin et al, "Confirmed Bulk Ablation and Therapy Monitoring Using Intracorporeal Image-Treat Ultrasound Arrays," 4th International Symposium on Therapeutic Ultrasound, Sep. 19, 2004.
- Makin et al., "Miniaturized Ultrasound Arrays for Interstitial Ablation and Imaging," *UltraSound Med. Biol.* 2005, Nov. 1, 2005, pp. 1539-1550, vol. 31(11).
- Manohar et al, "Photoacoustic mammography laboratory prototype: imaging of breast tissue phantoms," *Journal of Biomedical Optics*, Nov./Dec. 2004, pp. 1172-1181, vol. 9, No. 6.
- Mast et al, "Bulk Ablation of Soft Tissue with Intense Ultrasound; Modeling and Experiments," *J. Acoust. Soc. Am.*, Oct. 1, 2005, pp. 2715-2724, vol. 118(4).
- Meshkinpour, Azin, et al., "Treatment of Hypertrophic Scars and Keloids With a Radiofrequency Device: A Study of Collagen Effects" *Lasers in Surgery and Medicine* 37:343-349 (2005).
- Minkis, K., et al., "Ultrasound skin tightening". *Dermatol Clin*, 2014. 32(1): p. 71-7.
- Mitragotri, S., "Healing sound: the use of ultrasound in drug delivery and other therapeutic applications," *Nature Reviews; Drug Delivery*, pp. 255-260, vol. 4 (Mar. 2005).
- Mosser, David M. et al., "Exploring the full spectrum of macrophage activation" *Nat Rev Immunol*; 8(12): 958-969. (Dec. 2008).
- Murota, Sei-Itsu, et al., "Stimulatory Effect of Prostaglandins on the Production of Hexamine-Containing Substances by Cultured Fibroblasts (3) Induction of Hyaluronic Acid Synthetase by Prostaglandin" Department of Pharmacology, Tokyo Metropolitan Institute of Gerontology, Itabashiku, Tokyo-173, Japan. (Nov. 1977, vol. 14, No. 5).
- Murota, Sei-Itsu, et al., "The Stimulatory Effect of Prostaglandins on Production of Hexamine-Containing Substances by Cultured Fibroblasts" Department of Pharmacology, Tokyo Metropolitan Institute of Gerontology, Itabashiku, Tokyo-173, Japan. (Aug. 1976, vol. 12, No. 2).
- Nestor, M.S. et al., "Safety and Efficacy of Micro-focused Ultrasound Plus Visualization for the Treatment of Axillary Hyperhidrosis". *J Clin Aesthet Dermatol*, 2014. 7(4): p. 14-21.
- Oni, G., et al. "Response to 'comments on evaluation of microfocused ultrasound system for improving skin laxity and tightening in the lower face'". *Aesthet Surg J*. Mar. 2015;35(3):NP83-4.
- Oni, G., et al., "Evaluation of a Microfocused Ultrasound System for Improving Skin Laxity and Tightening in the Lower Face". *Aesthet Surg J*, 2014. 38:861-868.
- Pak, C.S., et al., "Safety and Efficacy of Ulthera in the Rejuvenation of Aging Lower Eyelids: A Pivotal Clinical Trial". *Aesthetic Plast Surg*, 2014.
- Paradossi et al., "Poly(vinyl alcohol) as versatile biomaterial for potential biomedical applications," *Journal of Materials Science: Materials in Medicine*, 2003, pp. 687-691, vol. 14.
- Pritzker, R.N., et al., "Updates in noninvasive and minimally invasive skin tightening". *Semin Cutan Med Surg*. Dec. 2014;33(4):182-7.
- Pritzker, R.N., et al., "Comparison of different technologies for noninvasive skin tightening". *Journal of Cosmetic Dermatology*, 13, 315-323. (2014).
- Rappolee, Daniel A., et al., "Wound Macrophages Express TGF and Other Growth Factors in Vivo: Analysis by mRNA Phenotyping" *Science*, vol. 241, No. 4866 (Aug. 1988).
- Reid, Gavin, et al., "Tandem Mass spectrometry of ribonuclease A and B: N-linked glycosylation site analysis of whole protein ions," *Analytical Chemistry*. Feb. 1, 2002, vol. 74, No. 3, pp. 577-583.
- Righetti et al, "Elastographic Characterization of HIFU-Induced Lesions in Canine Livers," 1999, *Ultrasound in Med & Bio*, vol. 25, No. 7, pp. 1099-1113.
- Rokhsar, C., et al., "Safety and efficacy of microfocused ultrasound in tightening of lax elbow skin". *Dermatol Surg*. 2015; 41(7):821-6.
- Rosenberg, Carol S. "Wound Healing in the Patient with Diabetes Mellitus" *Nursing Clinics of North America*, vol. 25, No. 1, (Mar. 1990).
- Saad et al., "Ultrasound-Enhanced Effects of Adriamycin Against Murine Tumors," *Ultrasound in Med. & Biol.* vol. 18, No. 8, pp. 715-723 (1992).
- Sabet-Peyman, E.J. et al., "Complications Using Intense Ultrasound Therapy to Treat Deep Dermal Facial Skin and Subcutaneous Tissues". *Dermatol Surg* 2014; 40:1108-1112.
- Sandulache, Vlad C. et al., "Prostaglandin E2 inhibition of keloid fibroblast migration, contraction, and transforming growth factor (TGF)-B1-induced collagen synthesis" *Wound Rep Reg* 15 122-133, 2007. (2007).
- Sanghvi, N.T., et al., "Transrectal Ablation of Prostate Tissue Using Focused Ultrasound," 1993 *Ultrasonics Symposium*, IEEE, pp. 1207-1210.
- Sasaki, G.H. et al., "Clinical Efficacy and Safety of Focused-Image Ultrasonography: A 2-Year Experience". *Aesthet Surg J*, 2012.
- Sasaki, G.H. et al., "Microfocused Ultrasound for Nonablative Skin and Subdermal Tightening to the Periorbitum and Body Sites: Preliminary Report on Eighty-Two Patients". *Journal of Cosmetics, Dermatological Sciences and Applications*, 2012, 2, 108-116.
- Sassen, Sander, "ATI's R520 architecture, the new king of the hill?" <http://www.hardwareanalysis.com/content/article/1813>, Sep. 16, 2005, 2 pages.
- Seip, Ralf, et al., "Noninvasive Detection of Thermal Effects Due to Highly Focused Ultrasonic Fields," *IEEE Symposium*, pp. 1229-1232, vol. 2, Oct. 3-Nov. 1993.
- Seip, Ralf, et al., "Noninvasive Estimation of Tissue Temperature Response to Heating Fields Using Diagnostic Ultrasound," *IEEE Transactions on Biomedical Engineering*, vol. 42, No. 8, Aug. 1995, pp. 828-839.
- Simon et al., "Applications of Lipid-Coated Microbubble Ultrasound Contrast to Tumor Therapy," *Ultrasound in Med. & Biol.* vol. 19, No. 2, pp. 123-125 (1993).
- Sklar, L.R., et al., "Use of transcutaneous ultrasound for lipolysis and skin tightening: a review". *Aesthetic Plast Surg*, 2014. 38(2): p. 429-41.
- Smith, Nadine Barrie, et al., "Non-invasive In Vivo Temperature Mapping of Ultrasound Heating Using Magnetic Resonance Techniques", 1994 *Ultrasonics Symposium*, pp. 1829-1832, vol. 3.
- Suh, D.H., et al., "A intense-focused ultrasound tightening for the treatment of infraorbital laxity". *J Cosmet Laser Ther*. 2012. 14(6): p. 290-5.

(56)

## References Cited

## OTHER PUBLICATIONS

- Suh, D.H., et al., "Comparative histometric analysis of the effects of high-intensity focused ultrasound and radiofrequency on skin". *J Cosmet Laser Ther.* Mar. 2015 24:1-7.
- Suh, D.H., et al., "Intense Focused Ultrasound Tightening in Asian Skin: Clinical and Pathologic Results" *American Society for Dermatologic Surgery, Inc.*; 37:1595-1602. (2011).
- Surry et al., "Poly(vinyl alcohol) cryogel phantoms for use in ultrasound and MR imaging." *Phys. Med. Biol.*, Dec. 6, 2004, pp. 5529-5546, vol. 49.
- Syka J. E. P. et al., "Peptide and Protein Sequence Analysis by Electron Transfer Dissociation Mass Spectrometry," *Proceedings of the National Academy of Sciences of USA, National Academy of Science, Washington, DC*, vol. 101, No. 26, Jun. 29, 2004, pp. 9528-9533.
- Talbert, D. G., "An Add-On Modification for Linear Array Real-Time Ultrasound Scanners to Produce 3D Displays," *UTS Int'l 1977 Brighton, England* (Jun. 28-30, 1977) pp. 57-67.
- Tata et al., "Interaction of Ultrasound and Model Membrane Systems: Analyses and Predictions," *American Chemical Society, Phys. Chem.* 1992, 96, pp. 3548-3555.
- Ueno, S., et al., "Ultrasound Thermometry in Hyperthermia", 1990 *Ultrasonic Symposium*, pp. 1645-1652.
- Verhofstad, Michiel H.J. et al., "Collagen Synthesis in rat skin and ileum fibroblasts is affected differently by diabetes-related factors" *Int. J. Exp. Path.* (1998), 79, 321-328.
- Wang, H., et al., "Limits on Focused Ultrasound for Deep Hyperthermia", 1994 *Ultrasonic Symposium*, Nov. 1-4, 1994, pp. 1869-1872, vol. 3.
- Wasson, Scott, "NVIDIA's GeForce 7800 GTX graphics processor Power MADD," <http://techreport.com/reviews/2005q2/geforce-7800gtx/index.x?pg=1>, Jun. 22, 2005, 4 pages.
- Weiss, M., "Commentary: noninvasive skin tightening: ultrasound and other technologies: where are we in 2011?" *Dermatol Surg.* 2012. 38(1): p. 28-30.
- White et al "Selective Creating of Thermal Injury Zones in the Superficial Musculoaponeurotic System Using Intense Ultrasound Therapy," *Arch Facial Plastic Surgery*, Jan./Feb. 2007, vol. 9, No. 1 (pp. 22-29).
- White, W. M., et al., "Selective Transcutaneous Delivery of Energy to Facial Subdermal Tissues Using the Ultrasound Therapy System" [abstr]. *American Society for Laser Medicine and Surgery Abstracts*, p. 37 #113 (Apr. 2006).
- White, W. Matthew, et al., "Selective Transcutaneous Delivery of Energy to Porcine Soft Tissues Using Intense Ultrasound (IUS)" *Lasers in Surgery and Medicine* 40:67-75 (2008).
- Woodward, J.A., et al. "Safety and Efficacy of Combining Microfocused Ultrasound With Fractional CO<sub>2</sub> Laser Resurfacing for Lifting and Tightening the Face and Neck". *Dermatol Surg.* Dec. 2014 40:S190-S193.
- Zelickson, Brian D. et al., "Histological and Ultrastructural Evaluation of the Effects of a Radiofrequency-Based Nonablative Dermal Remodeling Device, A Pilot Study" *Arch Dermatol*, vol. 140, (Feb. 2004).
- Ulthera, Inc., Petition for *Inter Partes* Review filed Jul. 19, 2016 in Re U.S. Pat. No. 6,113,559; IPR2016-01459; 63 pages (Filed Jul. 19, 2016).
- Ulthera Exhibit 1001, U.S. Pat. No. 6,113,559 to Klopotek, filed Jul. 19, 2016 in re IPR2016-01459.
- Ulthera Exhibit 1002, Patent file history of U.S. Pat. No. 6,113,559 Klopotek filed Jul. 19, 2016 in re IPR2016-01459.
- Ulthera Exhibit 1003, Declaration of Expert Witness Mark E. Schafer, Ph.D. filed Jul. 19, 2016 in re IPR2016-01459.
- Ulthera Exhibit 1004, Curriculum Vitae of Mark E. Schafer, Ph.D. filed Jul. 19, 2016 in re IPR2016-01459.
- Ulthera Exhibit 1005, International PCT Publication WO96/34568 Knowlton filed Jul. 19, 2016 in re IPR2016-01459.
- Ulthera Exhibit 1006, French Patent No. 2,672,486, Technomed patent filed Jul. 19, 2016 in re IPR2016-01459.
- Ulthera Exhibit 1007, English translation of French Patent No. 2,672,486, Technomed filed Jul. 19, 2016 in re IPR2016-01459.
- Ulthera Exhibit 1008, International PCT Publication WO93/12742, Technomed PCT filed Jul. 19, 2016 in re IPR2016-01459.
- Ulthera Exhibit 1009, English translation of International PCT Publication WO93/12742, Technomed PCT filed Jul. 19, 2016 in re IPR2016-01459.
- Ulthera Exhibit 1010, U.S. Pat. No. 5,601,526, which claims priority to Technomed PCT filed Jul. 19, 2016 in re IPR2016-01459.
- Ulthera Exhibit 1011, Patent file history for European Patent Application No. 98964890.2, Klopotek filed Jul. 19, 2016 in re IPR2016-01459.
- Ulthera Exhibit 1012, Translator Declaration filed Jul. 19, 2016 in re IPR2016-01459.
- Ulthera Exhibit 1013, U.S. Pat. No. 5,230,334 to Klopotek filed Jul. 19, 2016 in re IPR2016-01459.
- Ulthera Exhibit 1014, U.S. Pat. No. 5,755,753 to Knowlton filed Jul. 19, 2016 in re IPR2016-01459.
- Ulthera Exhibit 1015, Excerpts from the American Medical Association Encyclopedia of Medicine (1989) filed Jul. 19, 2016 in re IPR2016-01459.
- Ulthera Exhibit 1016, The Simultaneous Study of Light Emissions and Shock Waves Produced by Cavitation Bubbles, G. Gimenez, J. Acoust. Soc. Am. 71(4), Apr. 1982, pp. 839-847 (filed Jul. 19, 2016 in re IPR2016-01459).
- Ulthera Exhibit 1017, Excerpts from Gray's Anatomy (1995) (filed Jul. 19, 2016 in re IPR2016-01459).
- Ulthera Exhibit 1018, Anatomy of the Superficial Venous System, Comjen G.M., *Dermatol. Surg.*, 1995; 21:35-45 (filed Jul. 19, 2016 in re IPR2016-01459).
- Ulthera Exhibit 1019, Section 2.6 from Ultrasonics Theory and Application, by G.L. Gooberman (Hart Publishing Co., 1969) (filed Jul. 19, 2016 in re IPR2016-01459).
- Ulthera Exhibit 1020, Deep Local Hyperthermia for Cancer Therapy: External Electromagnetic and Ultrasound Techniques, A.Y. Cheung and A. Neyzari, *Cancer Research* (Suppl.), vol. 44, pp. 4736-4744 (1984) (filed Jul. 19, 2016 in re IPR2016-01459).
- Decision on Institution of Inter Partes Review in Re U.S. Pat. No. 6,113,559; IPR2016-01459; 20 pages [011] (Dated Jan. 23, 2017).
- Dermafocuse Response to Institution of Inter Partes Review in Re U.S. Pat. No. 6,113,559; IPR2016-01459; 73 pages [018] (Dated Apr. 26, 2017).
- Dermafocuse Exhibit List in Re U.S. Pat. No. 6,113,559; IPR2016-01459; 5 pages [019] (Dated Apr. 26, 2017).
- Dermafocuse Exhibit 2002, Declaration of Mark Palmeri, in Re U.S. Pat. No. 6,113,559; IPR2016-01459; 136 pages (Filed Apr. 26, 2017).
- Dermafocuse Exhibit 2003, Deposition of Dr. Mark Schafer, in Re U.S. Pat. No. 6,113,559; IPR2016-01459; 327 pages (Filed Apr. 26, 2017).
- Dermafocuse Exhibit 2004, Amendment No. 4 to Ulthera Form S-1, in Re U.S. Pat. No. 6,113,559; IPR2016-01459; 308 pages (Filed Apr. 26, 2017).
- Dermafocuse Exhibit 2005, Excerpt from Churchill Livingstone, Gray's Anatomy (38th ed. 1995), in Re U.S. Pat. No. 6,113,559; IPR2016-01459; 7 pages (Filed Apr. 26, 2017).
- Dermafocuse Exhibit 2006, Bo Eklöf et al., "Revision of the CEAP Classification for Chronic Venous Disorders: Consensus Statement," *ACTA FAC MED NAISS*, vol. 25, No. 1 (2008), 3-10 in Re U.S. Pat. No. 6,113,559; IPR2016-01459; 7 pages (Filed Apr. 26, 2017).
- Dermafocuse Exhibit 2007, WebMD, "Varicose Veins and Spider Veins" downloaded from <http://www.webmd.com/skin-problems-and-treatments/guide/varicose-spider-veins#1> in Re U.S. Pat. No. 6,113,559; IPR2016-01459; 3 pages (Filed Apr. 26, 2017).
- Dermafocuse Exhibit 2008, John M. Porter et al, "Reporting Standards in Venous Disease: An Update," *Journal of Vascular Surgery*, vol. 21, No. 4 (1995), 635-645 in Re U.S. Pat. No. 6,113,559; IPR2016-01459; 11 pages (Filed Apr. 26, 2017).
- Dermafocuse Exhibit 2009, Kullervo Hynynen, "Review of Ultrasound Therapy," 1997 *Ultrasonics Symposium* (1997), 1305-1313, in Re U.S. Pat. No. 6,113,559; IPR2016-01459; 9 pages (Filed Apr. 26, 2017).

(56)

**References Cited**

## OTHER PUBLICATIONS

- Dermafocus Exhibit 2010, A.G. Visioli et al, "Preliminary Results of a Phase I Dose Escalation Clinical Trial Using Focused Ultrasound in the Treatment of Localised Tumours," *European Journal of Ultrasound*, vol. 9 (1999), 11-18, in Re U.S. Pat. No. 6,113,559; IPR2016-01459; 8 pages (Filed Apr. 26, 2017).
- Dermafocus Exhibit 2011, U.S. Pat. No. 5,143,063, issued on Sep. 1, 1992, Fellner, in Re U.S. Pat. No. 6,113,559; IPR2016-01459; 6 pages (Filed Apr. 26, 2017).
- Dermafocus Exhibit 2012, Hugh G. Beebe et al, "Consensus Statement: Classification and Grading of Chronic Venous Disease in the Lower Limbs," *European Journal of Vascular and Endovascular Surgery*, vol. 12 (1996), 487-492, in Re U.S. Pat. No. 6,113,559; IPR2016-01459; 6 pages (Filed Apr. 26, 2017).
- Dermafocus Exhibit 2013, Excerpt from Mosby's Medical Dictionary (3rd ed. 1990), in Re U.S. Pat. No. 6,113,559; IPR2016-01459; 4 pages (Filed Apr. 26, 2017).
- Dermafocus Exhibit 2014, Excerpt from Miller-Keane Encyclopedia & Dictionary of Medicine, Nursing, & Allied Health (5th ed. 1992), in Re U.S. Pat. No. 6,113,559; IPR2016-01459; 6 pages (Filed Apr. 26, 2017).
- Dermafocus Exhibit 2015, David J. Tibbs et al, *Varicose Veins, Venous Disorders, and Lymphatic Problems in the Lower Limbs* (1997), Chapter 4: Clinical Patterns of Venous Disorder I, 47-67, in Re U.S. Pat. No. 6,113,559; IPR2016-01459; 24 pages (Filed Apr. 26, 2017).
- Dermafocus Exhibit 2016, Mitchel P. Goldman et al, *Varicose Veins and Telangiectasias* (2nd ed. 1999), Chapter 22: Treatment of Leg Telangiectasias with Laser and High-Intensity Pulsed Light, 470-497, in Re U.S. Pat. No. 6,113,559; IPR2016-01459; 31 pages (Filed Apr. 26, 2017).
- Dermafocus Exhibit 2017, Email from Anderson to Klopotek dated May 25, 2004, in Re U.S. Pat. No. 6,113,559; IPR2016-01459; 1 page (Filed Apr. 26, 2017).
- Dermafocus Exhibit 2018, List of Klopotek Patents, in Re U.S. Pat. No. 6,113,559; IPR2016-01459; 411 pages (Filed Apr. 26, 2017).
- Dermafocus Exhibit 2019, Declaration of Peter Klopotek Civil Action 15-cv-654-SLR, dated Nov. 2, 2016, in Re U.S. Pat. No. 6,113,559; IPR2016-01459; 1 page (Filed Apr. 26, 2017).
- Dermafocus Exhibit 2020, "Our Technology," downloaded from <http://jobs.ulthera.com/about> on Apr. 10, 2017, in Re U.S. Pat. No. 6,113,559; IPR2016-01459; 4 pages (Filed Apr. 26, 2017).
- Dermafocus Exhibit 2021, C. Damianou and K. Hynynen, "Focal Spacing and Near-Field Heating During Pulsed High Temperature Ultrasound Therapy," *Ultrasound in Medicine & Biology*, vol. 19, No. 9 (1993), 777-787, in Re U.S. Pat. No. 6,113,559; IPR2016-01459; 11 pages (Filed Apr. 26, 2017).
- Dermafocus Exhibit 2022, Excerpt from Mosby's Medical Dictionary (5th ed. 1997), in Re U.S. Pat. No. 6,113,559; IPR2016-01459; 5 pages (Filed Apr. 26, 2017).
- Dermafocus Exhibit 2023, Excerpt from Miller-Keane Encyclopedia & Dictionary of Medicine, Nursing, & Allied Health (6th ed. 1997), in Re U.S. Pat. No. 6,113,559; IPR2016-01459; 7 pages (Filed Apr. 26, 2017).
- Dermafocus Exhibit 2024, Excerpt from Stedman's Concise Medical Dictionary (3rd ed. 1997), in Re U.S. Pat. No. 6,113,559; IPR2016-01459; 4 pages (Filed Apr. 26, 2017).
- Dermafocus Exhibit 2025, Excerpt from Taber's Cyclopedic Medical Dictionary (18th ed. 1997), in Re U.S. Pat. No. 6,113,559; IPR2016-01459; 9 pages (Filed Apr. 26, 2017).
- Dermafocus Exhibit 2026, Bo Eklof et al, "Revision of the CEAP Classification for Chronic Venous Disorders: Consensus Statement," *Journal of Vascular Surgery*, vol. 40, No. 6 (2004), 1248-1252.e1, in Re U.S. Pat. No. 6,113,559; IPR2016-01459; 6 pages (Filed Apr. 26, 2017).
- Ulthera, Inc., Reply in Support of Petition for Inter Partes Review in Re U.S. Pat. No. 6,113,559; IPR2016-01459; 33 pages (Filed Aug. 2, 2017).
- Ulthera Exhibit 1022, Use of the Argon and Carbon Dioxide Lasers for Treatment of Superficial Venous Varicosities of the Lower Extremity, D. Apfelberg et al., *Lasers in Surgery and Medicine*, vol. 4,3, pp. 221-231 (1984) (filed Aug. 2, 2017 in re IPR2016-01459).
- Ulthera Exhibit 1023, 532-Nanometer Green Laser Beam Treatment of Superficial Varicosities of the Lower Extremities, T. Smith et al., *Lasers in Surgery and Medicine*, vol. 8,2, pp. 130-134 (1988) (filed Aug. 2, 2017 in re IPR2016-01459).
- Ulthera Exhibit 1024, Deposition Transcript of Dr. Mark Palmeri on Jul. 11, 2017 (filed Aug. 2, 2017 in re IPR2016-01459).
- Ulthera Exhibit 1025, Ulthera Oral Proceeding Demonstrative Slides (filed Oct. 2, 2017 in re IPR2016-01459).
- DermaFocus Exhibit 2027, DermaFocus Oral Proceeding Demonstrative Slides (filed Oct. 2, 2017 in re IPR2016-01459).
- Carruthers et al., "Consensus Recommendations for Combined Aesthetic Interventions in the Face Using Botulinum Toxin, Fillers, and Energy-Based Devices" *Dermatol Surg* 2016 (pp. 1-12).
- Microchip microID 125 kHz EFID System Design Guide, Microchip Technology Inc. (2004).
- PTAB Record of Oral Hearing held Oct. 4, 2017 in Re U.S. Pat. No. 6,113,559; IPR2016-01459; 67 pages (PTAB Document sent to Ulthera on Nov. 1, 2017).
- Final Written Decision of Inter Partes Review in Re U.S. Pat. No. 6,113,559; IPR2016-01459; 37 pages [030] (Entered Jan. 19, 2018).
- Ulthera, Inc., Petitioner Notice of Appeal to Federal Circuit 2018-1542 re: IPR2016-01459; 4 pages from [001] (no appendices) (Filed Feb 9, 2018).
- Federal Circuit Order Granting Ulthera Motion to Remand, re: 2018-1542; 4 pages [022] (Dated May 25, 2018).
- Adams et al., "High Intensity Focused Ultrasound Ablation of Rabbit Kidney Tumors" *Sonablate High-Intensity Focused Ultrasound device*; *Journal of Endourology* vol. 10, No. 1, (Feb. 1996).
- Driller et al., "Therapeutic Applications of Ultrasound: A Review" *IEEE Engineering in Medicine and Biology*; (Dec. 1987) pp. 33-40.
- Sonocare, Inc. *Therapeutic Ultrasound System Model CST-100 Instruction Manual* (1985).
- Webster et al. "The role of ultrasound-induced cavitation in the 'In vitro' stimulation of collagen synthesis in human fibroblasts"; *Ultrasonics* pp. 33-37 (Jan. 1980).
- Ulthera Brief (Corrected), Fed. Cir. Appeal Case 19-1006 from re: IPR2016-01459; 136 pages [030] (Dated Apr. 3, 2019).
- DermaFocus Brief (Corrected), Fed. Cir. Appeal Case 19-1006 from re: IPR2016-01459; 73 pages [032] (Dated Apr. 4, 2019).

\* cited by examiner

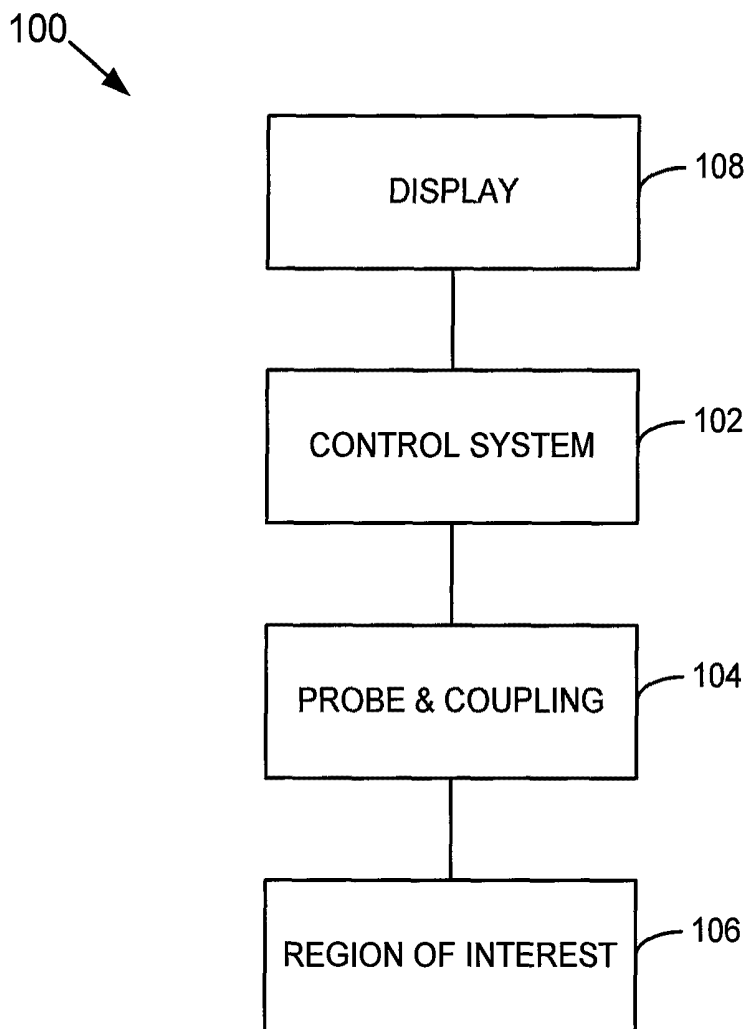

FIG. 1

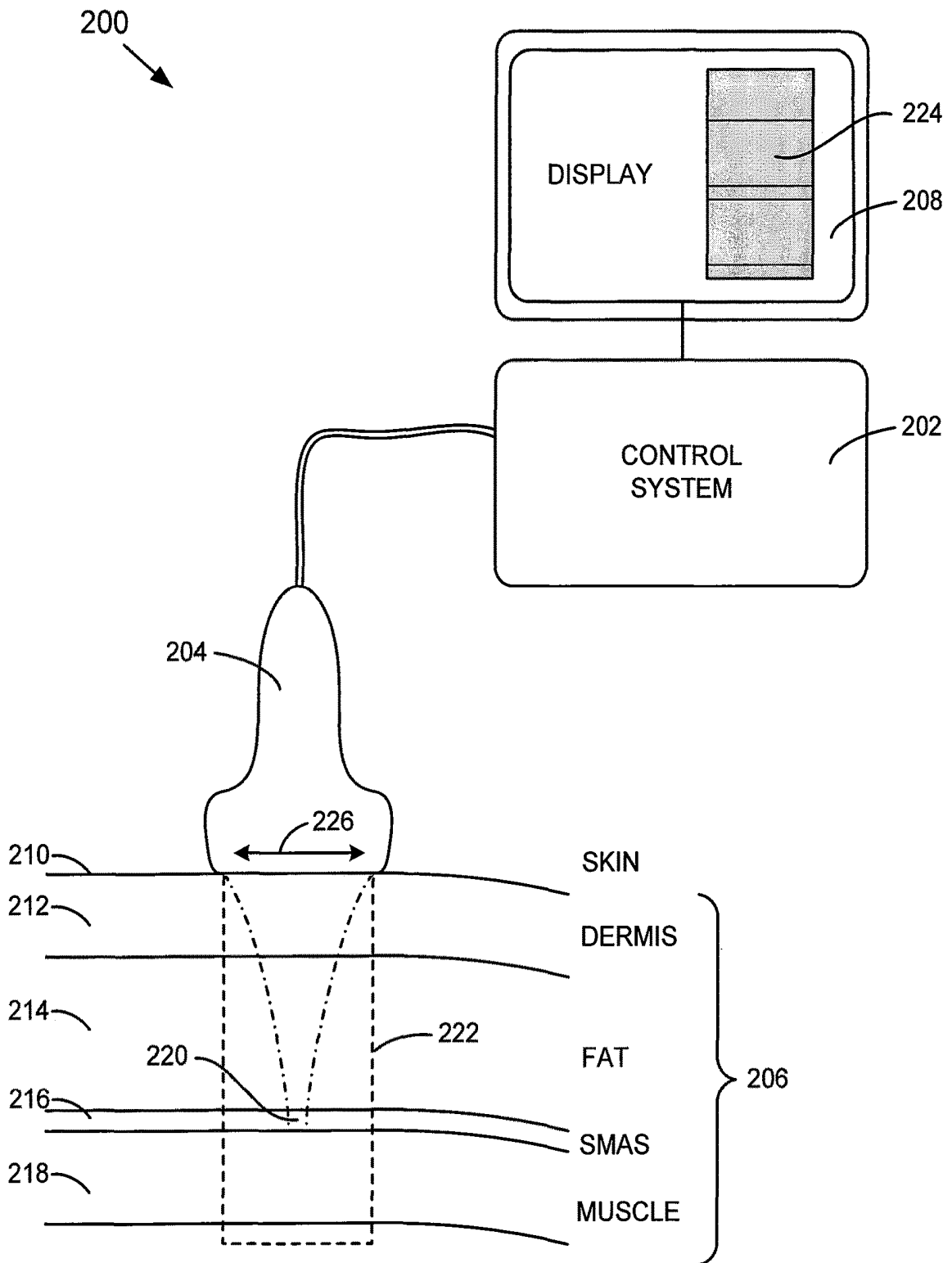

FIG. 2A

230

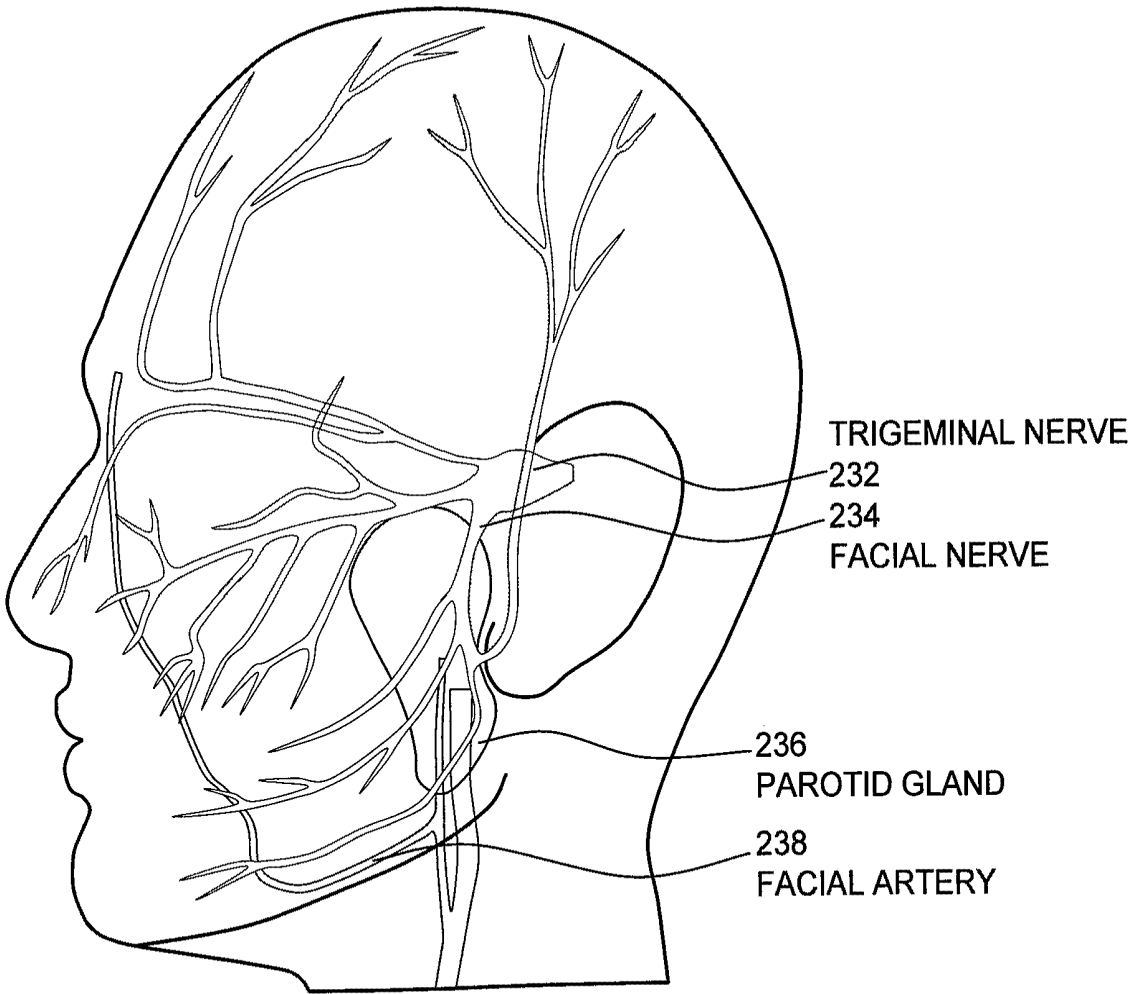

FIG. 2B

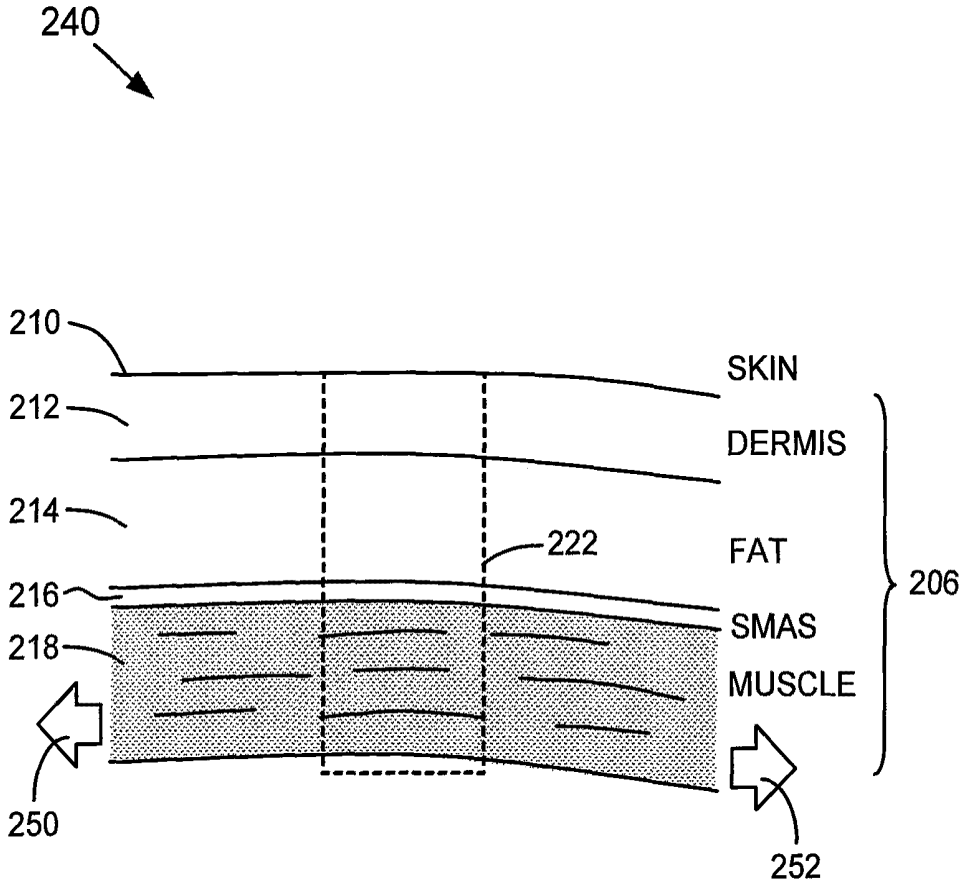

FIG. 2C

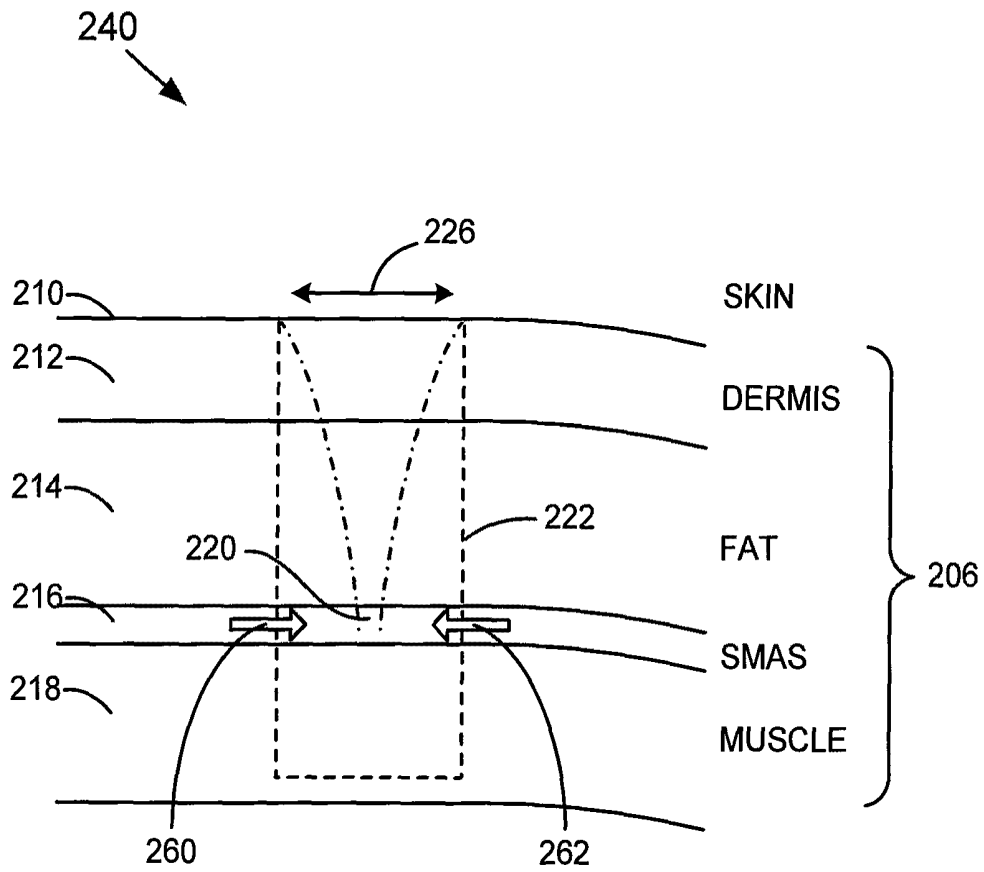

FIG. 2D

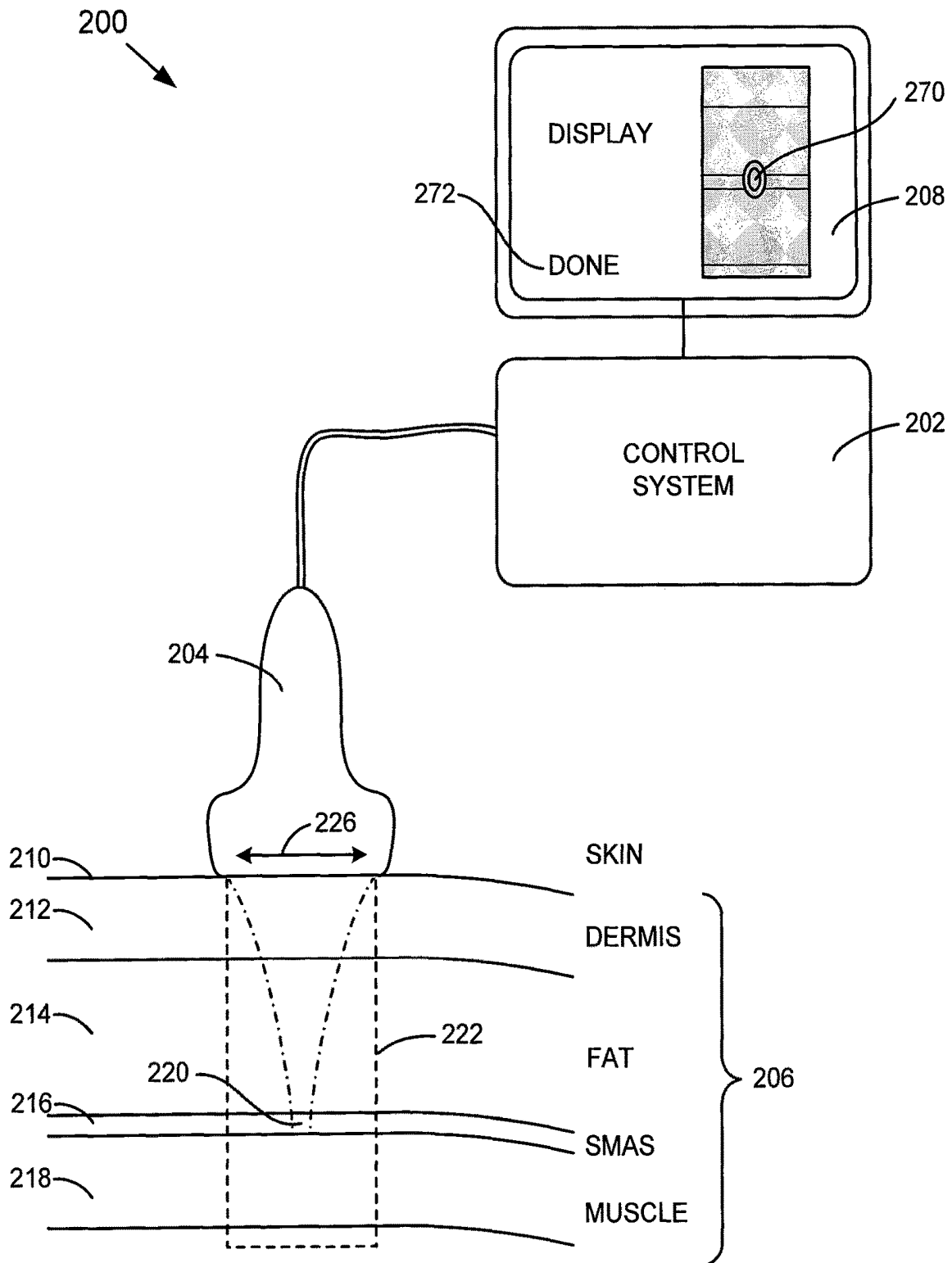

FIG. 2E

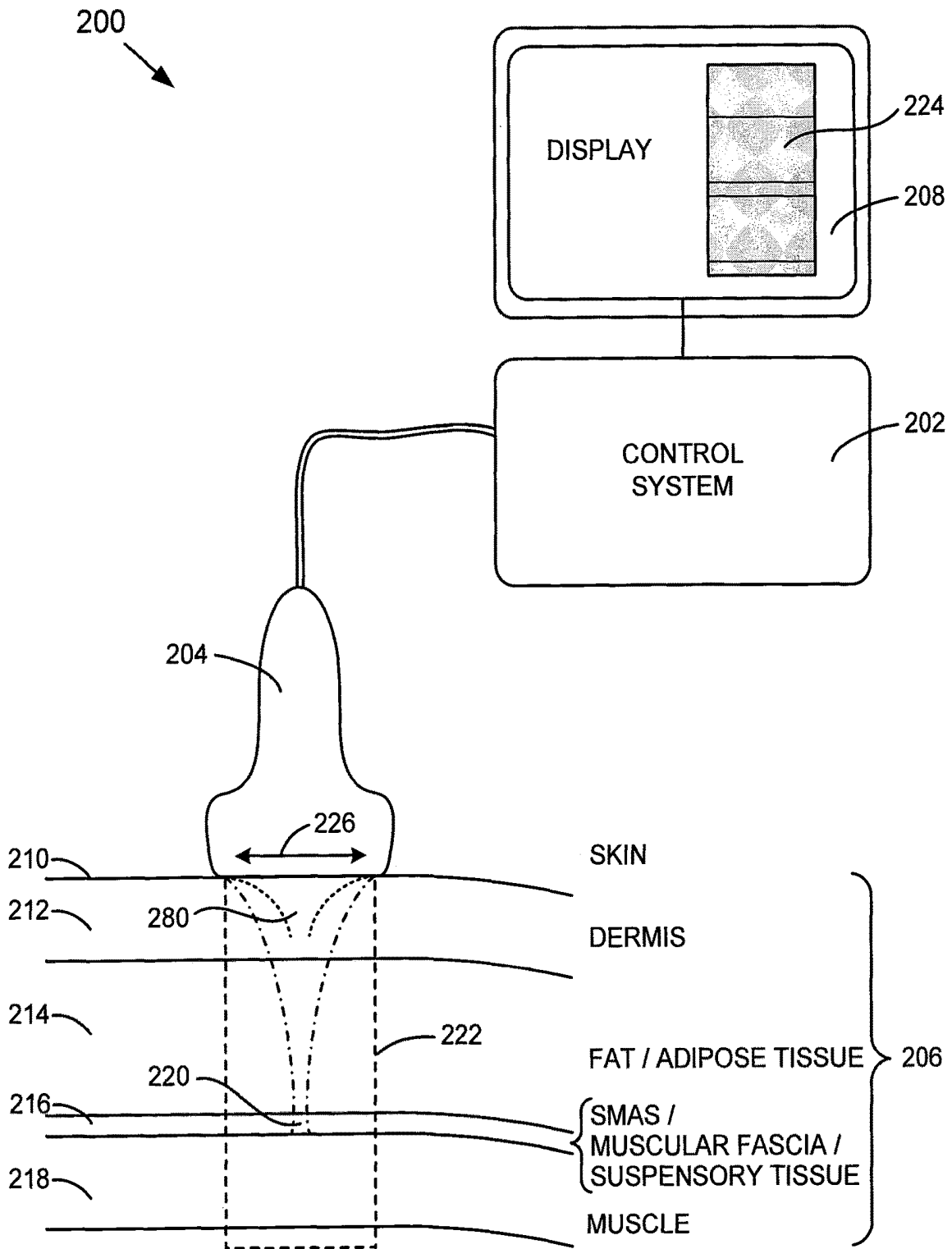

FIG. 2F

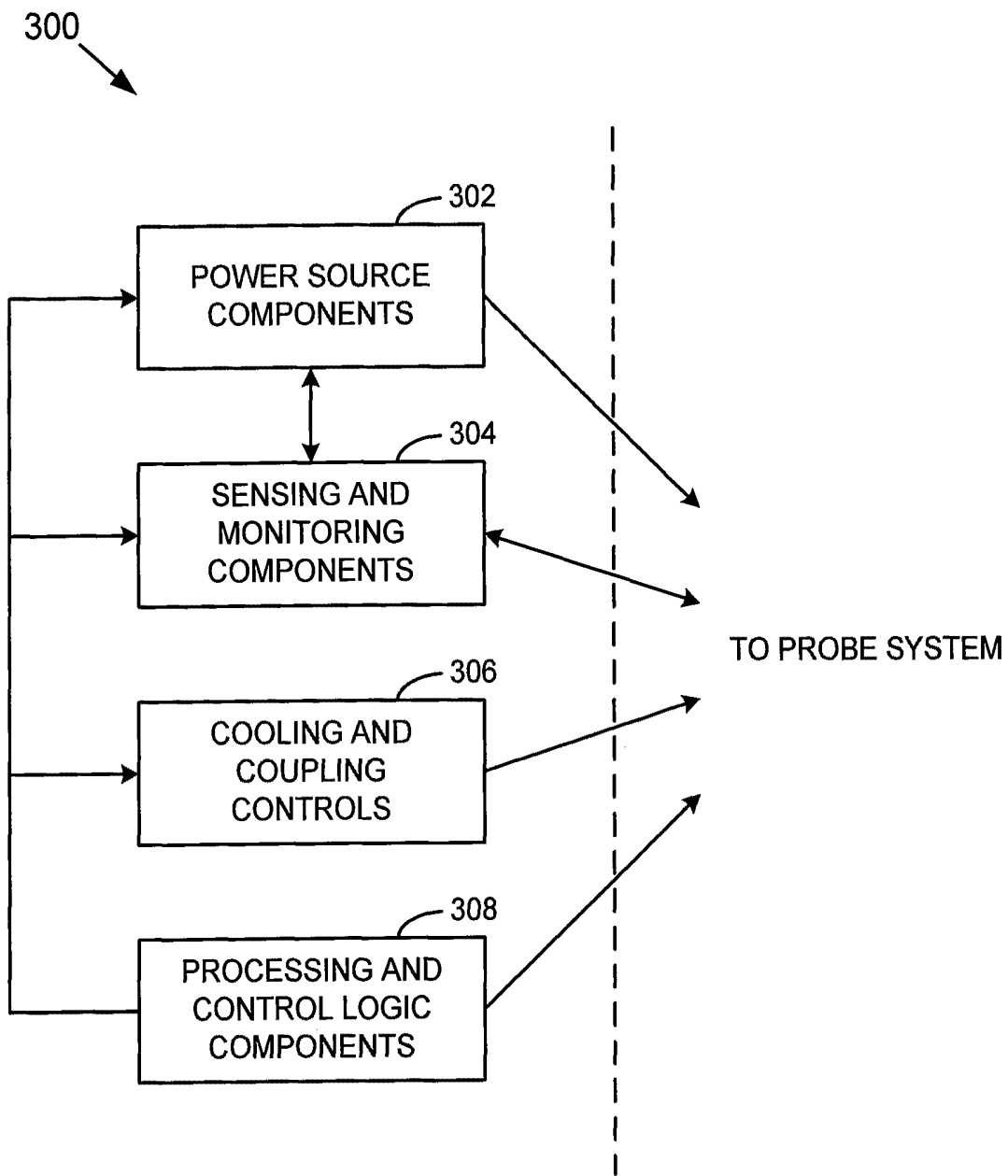
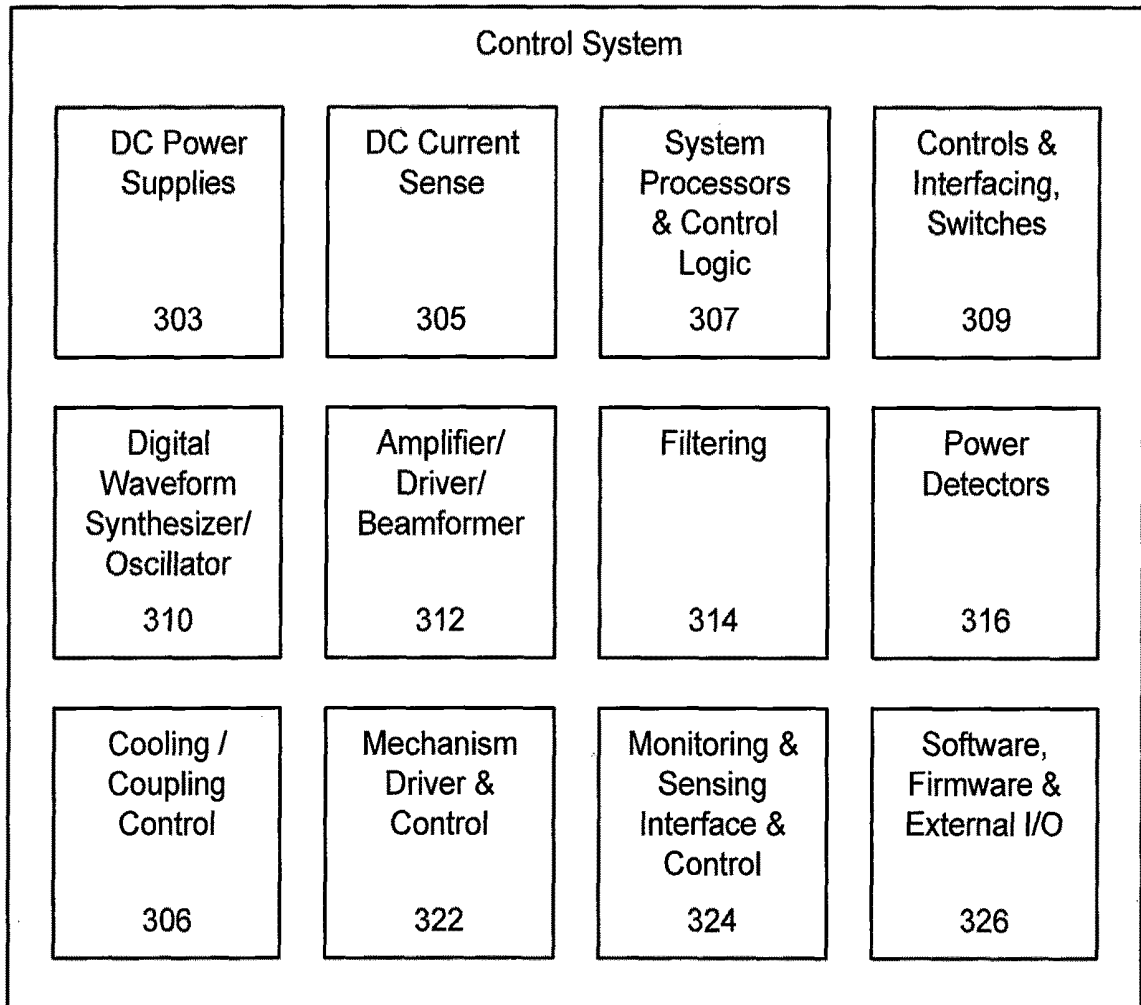

FIG. 3A

300  
↙



**FIG. 3B**

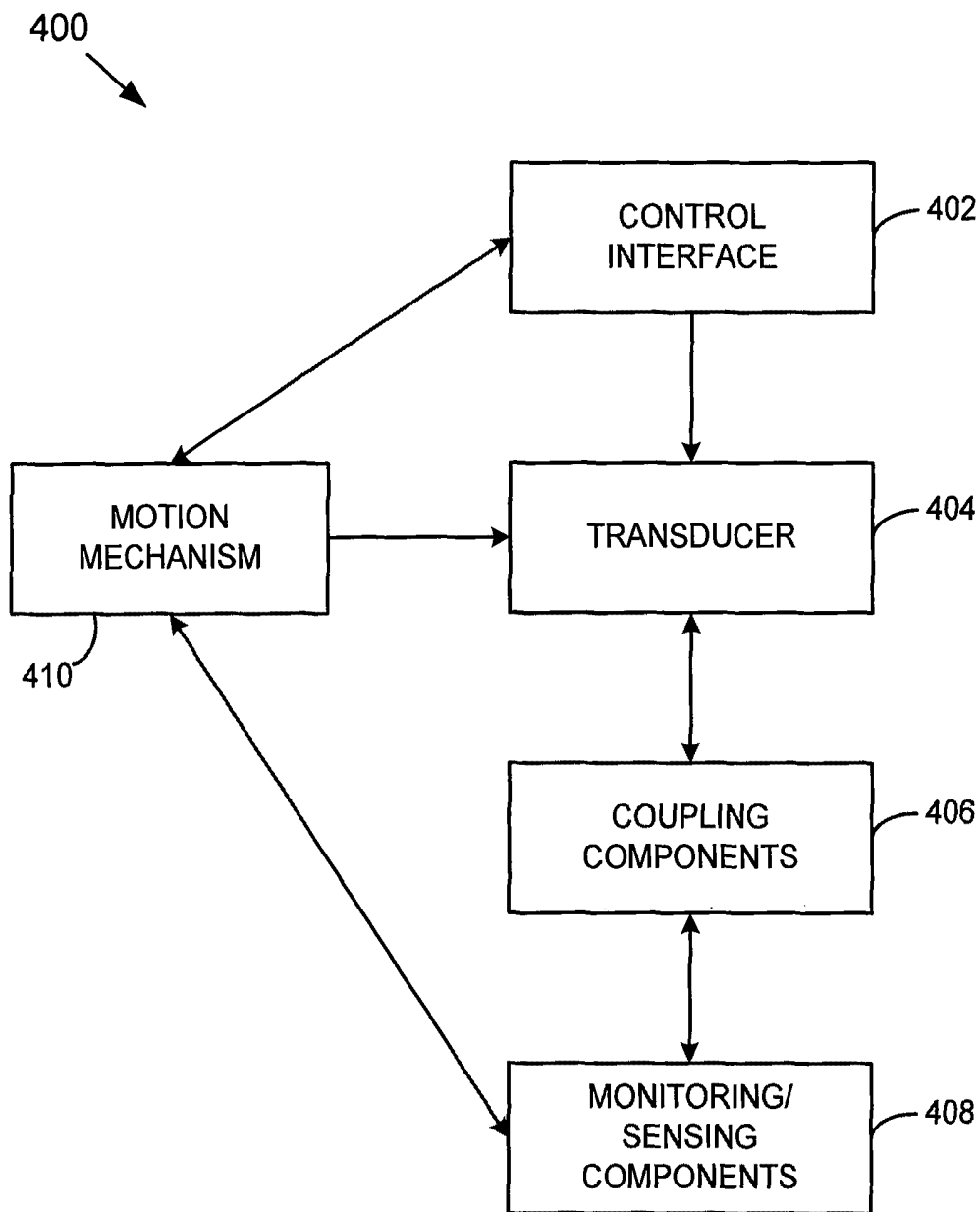

FIG. 4A

400  
↙

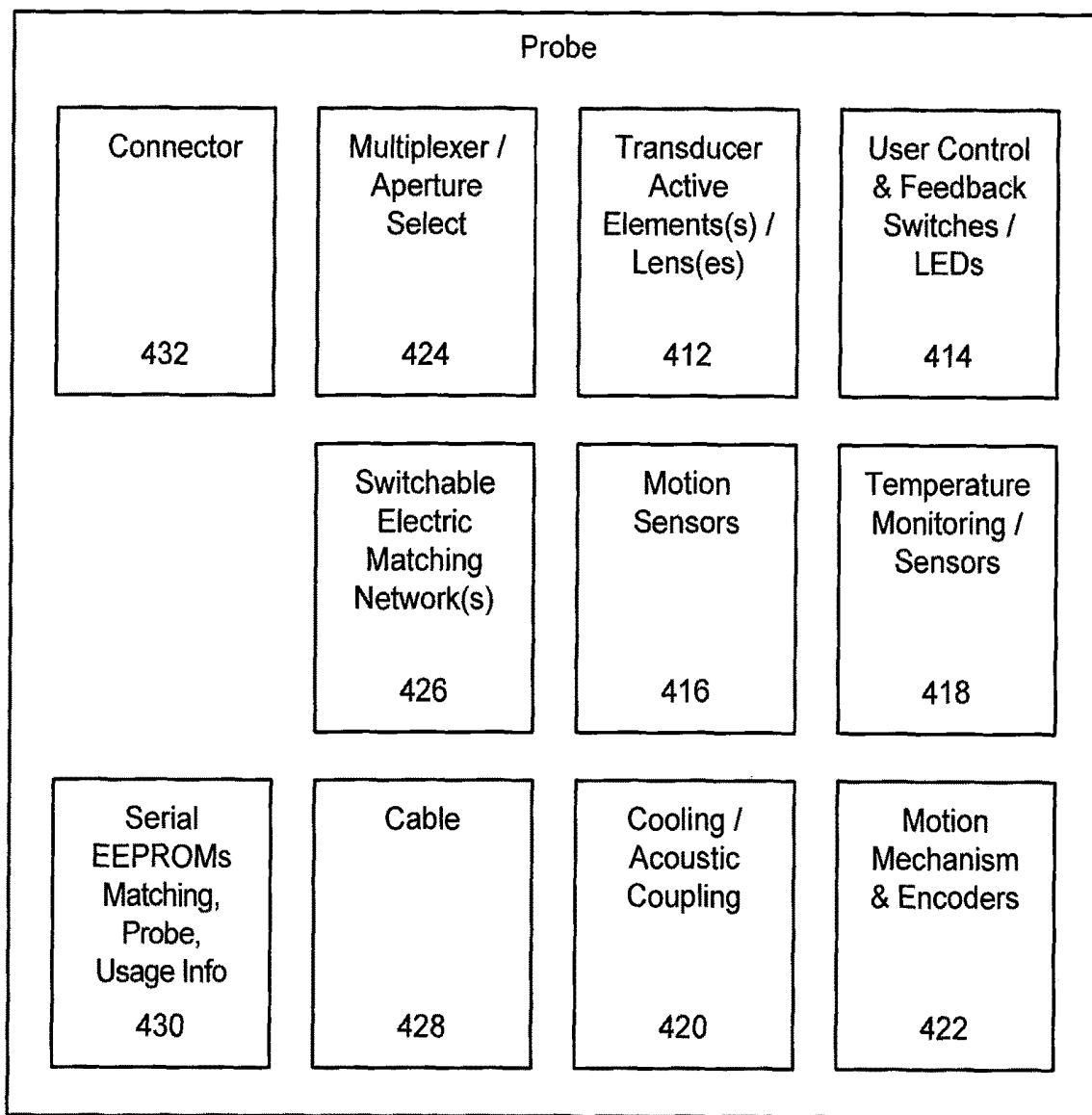

FIG. 4B

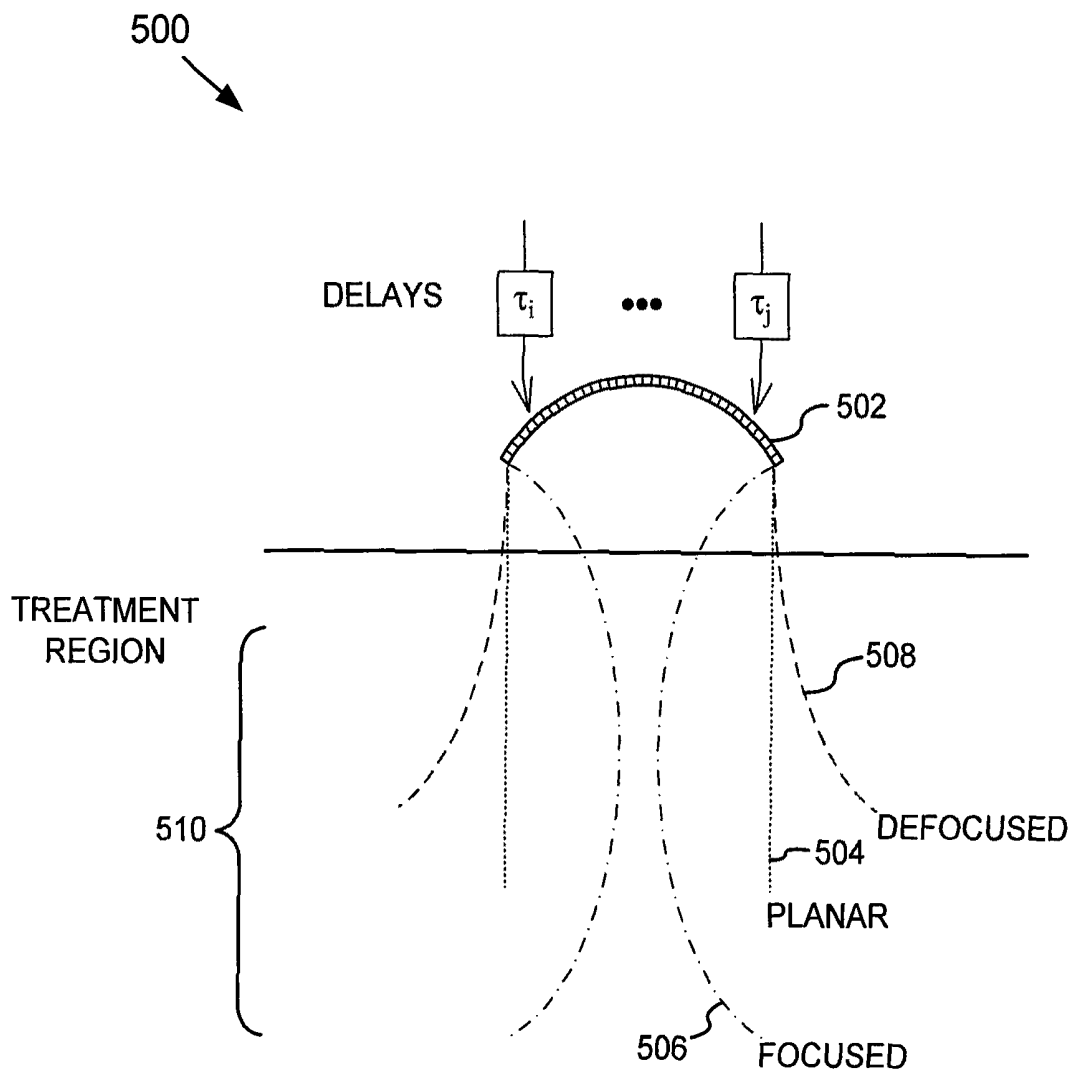

FIG. 5

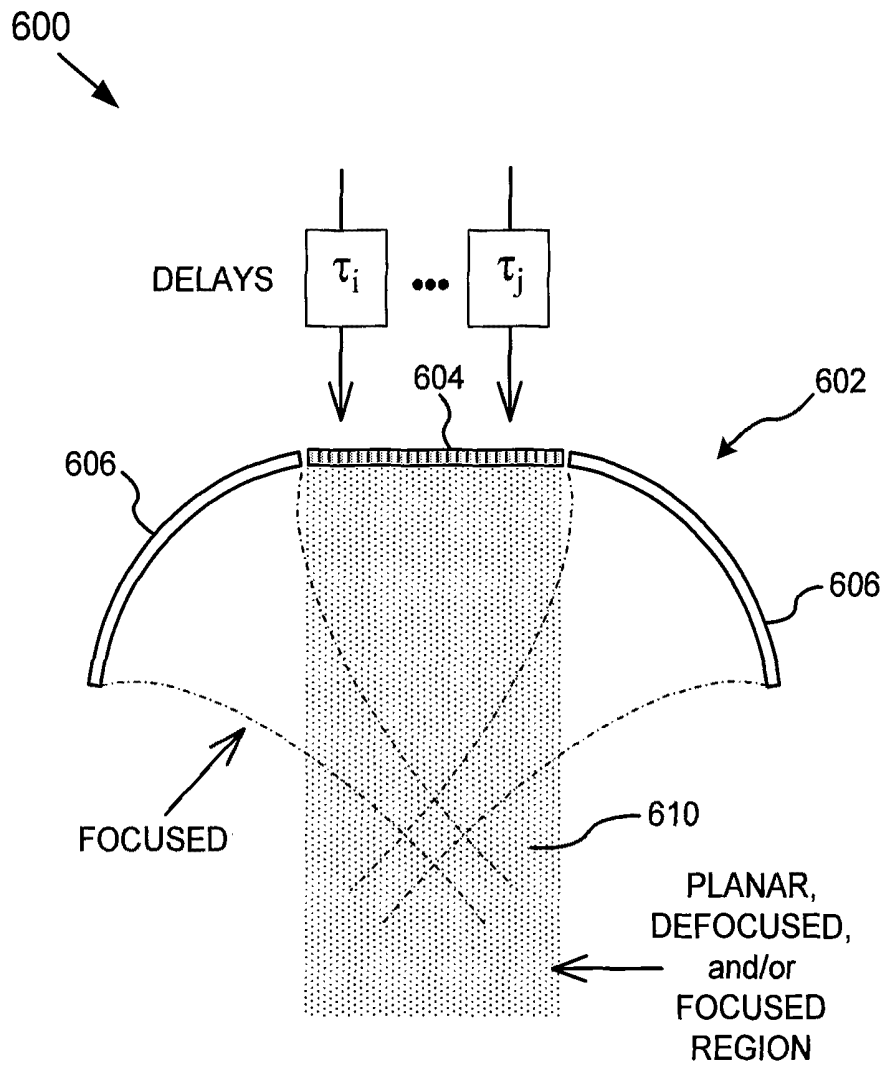

FIG. 6A

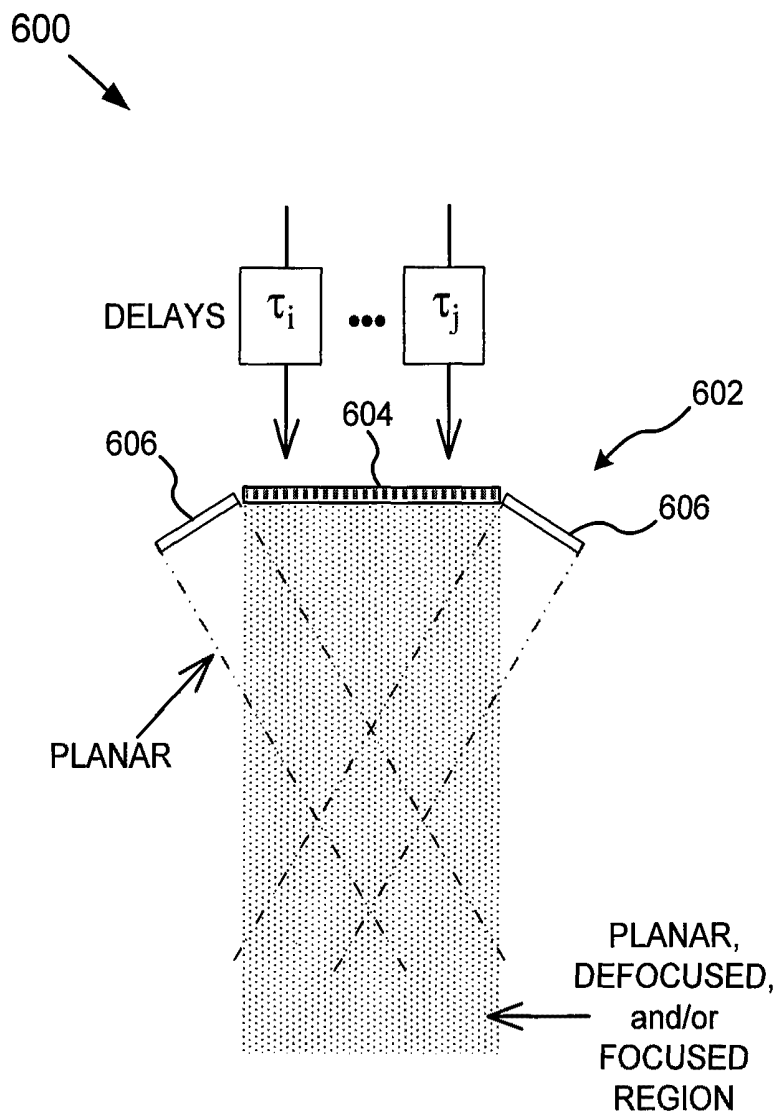

FIG. 6B

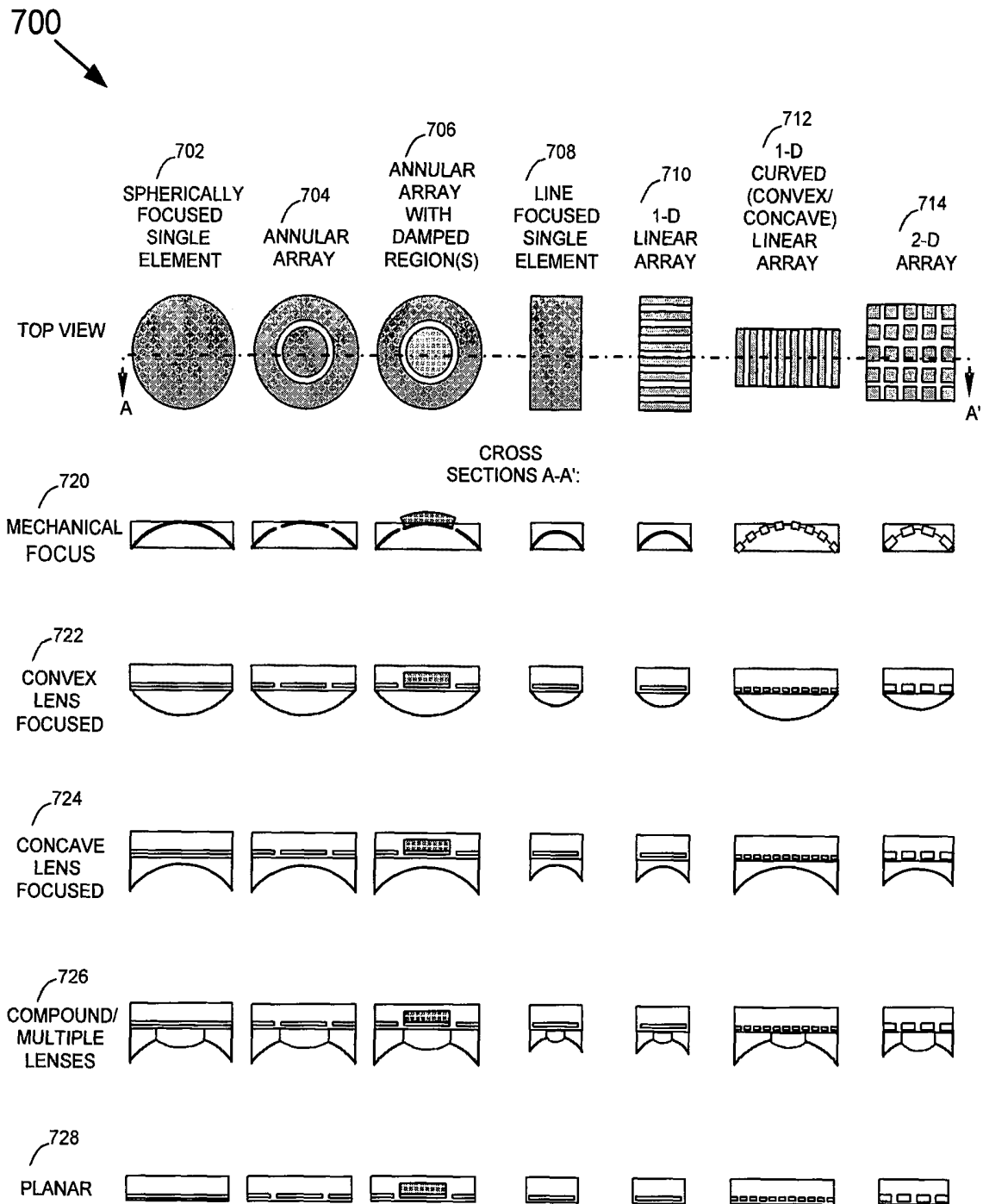

FIG. 7

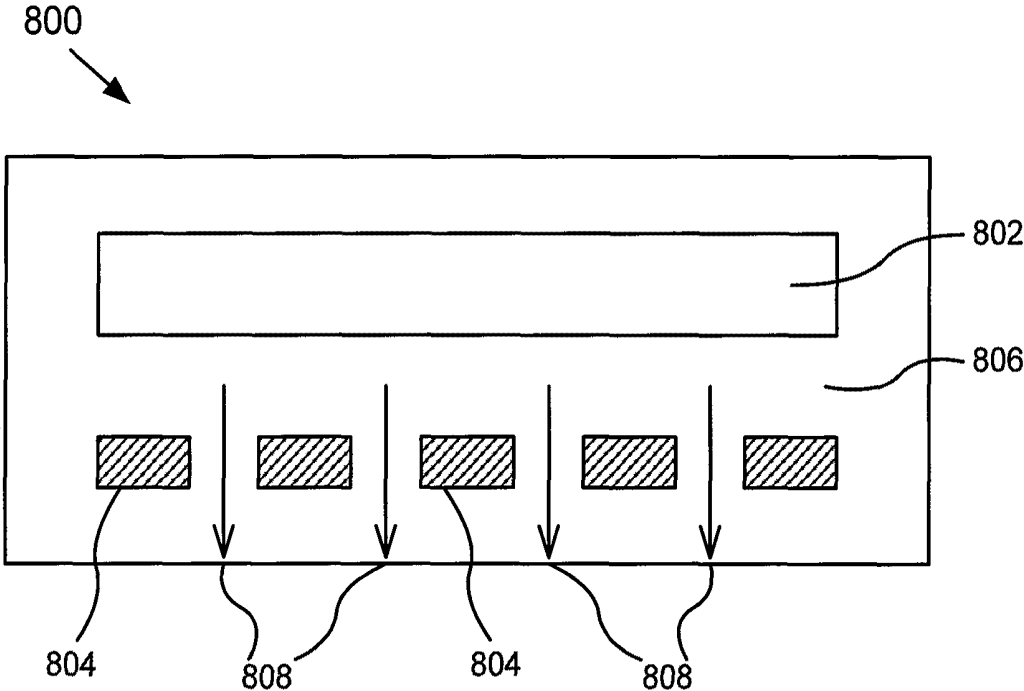

FIG. 8A

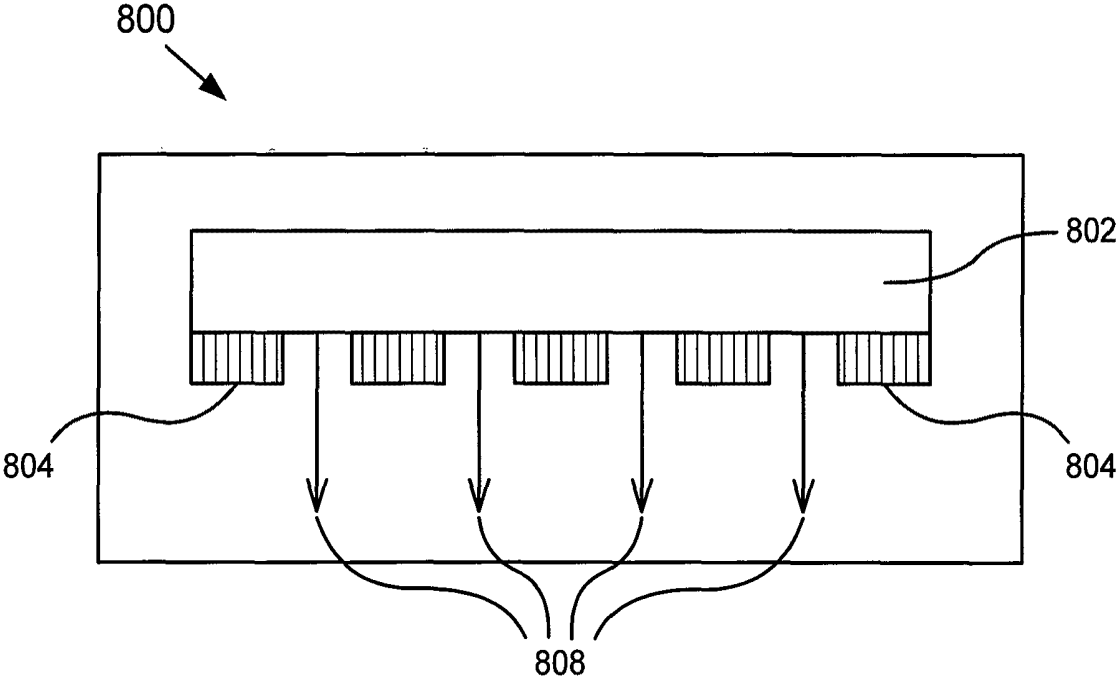

FIG. 8B

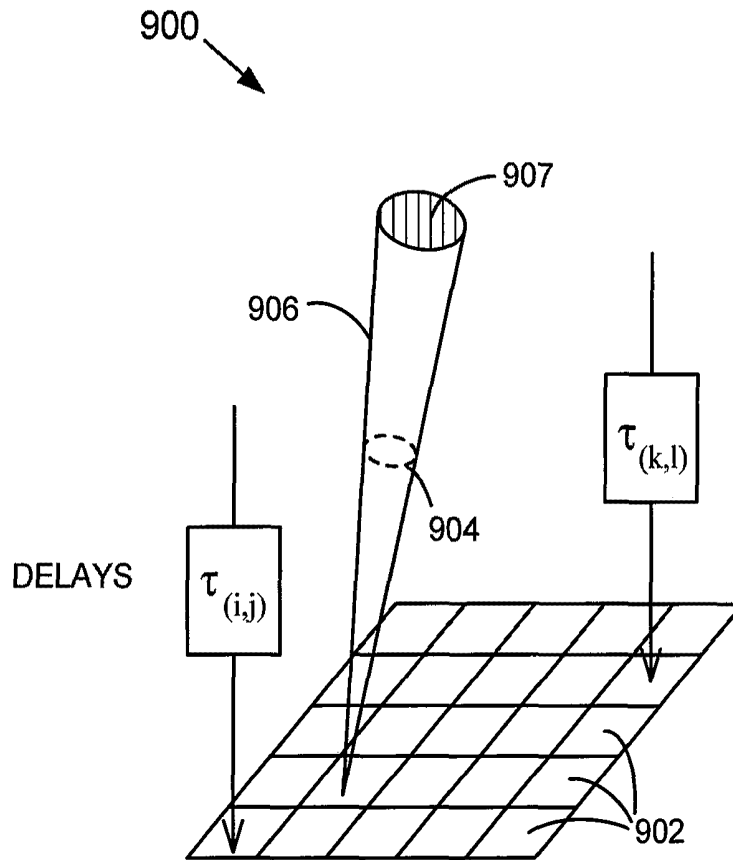

FIG. 9

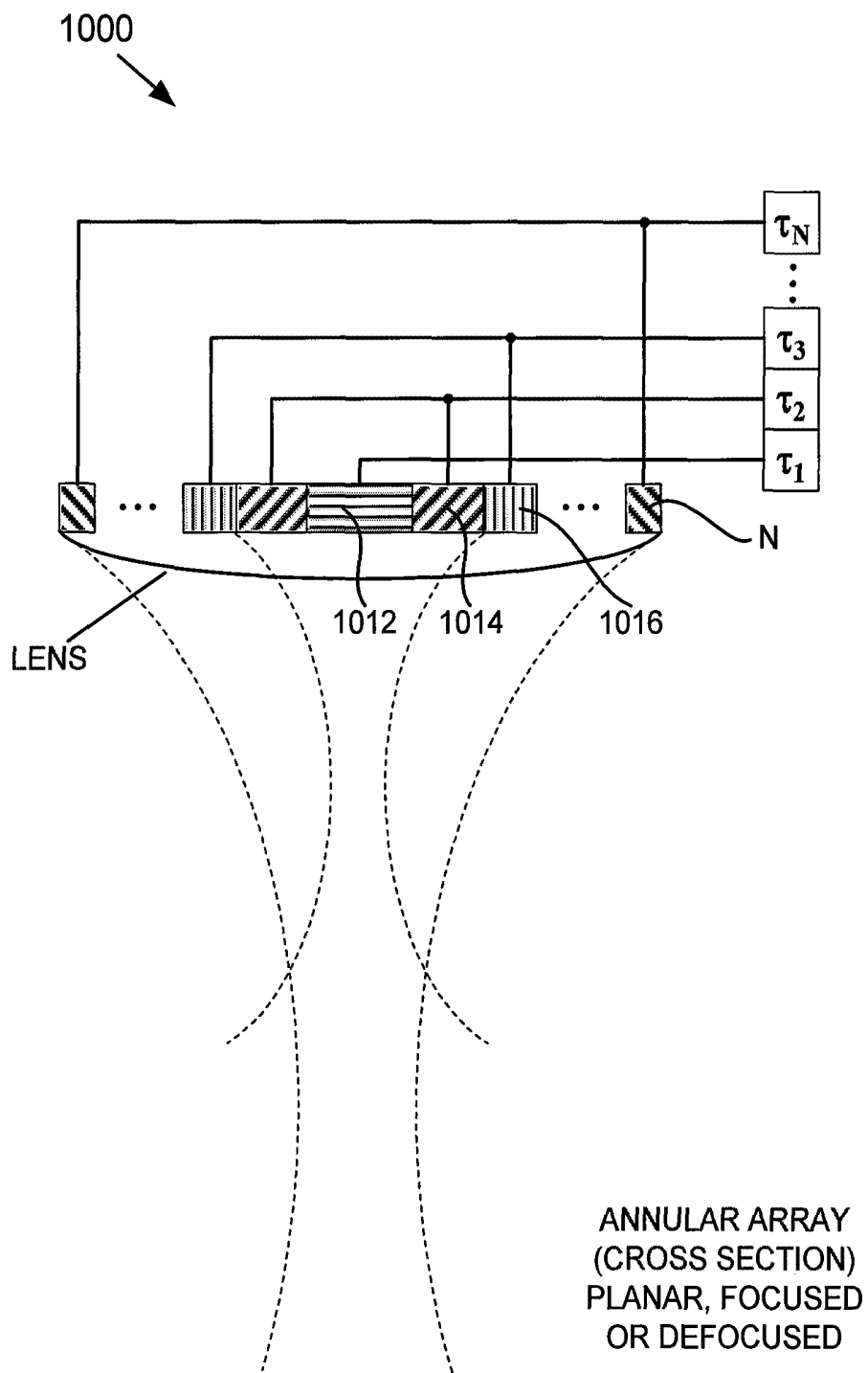

FIG. 10A

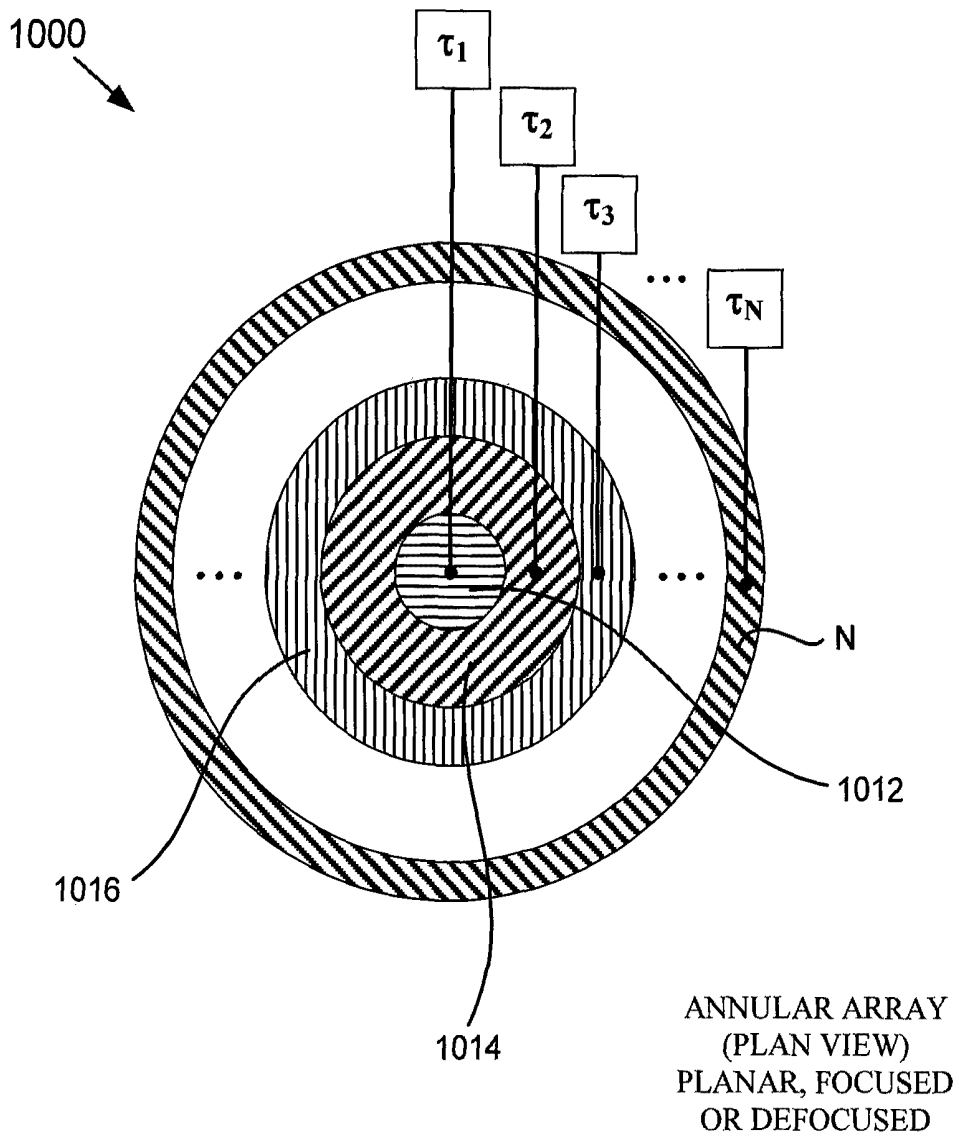

FIG. 10B

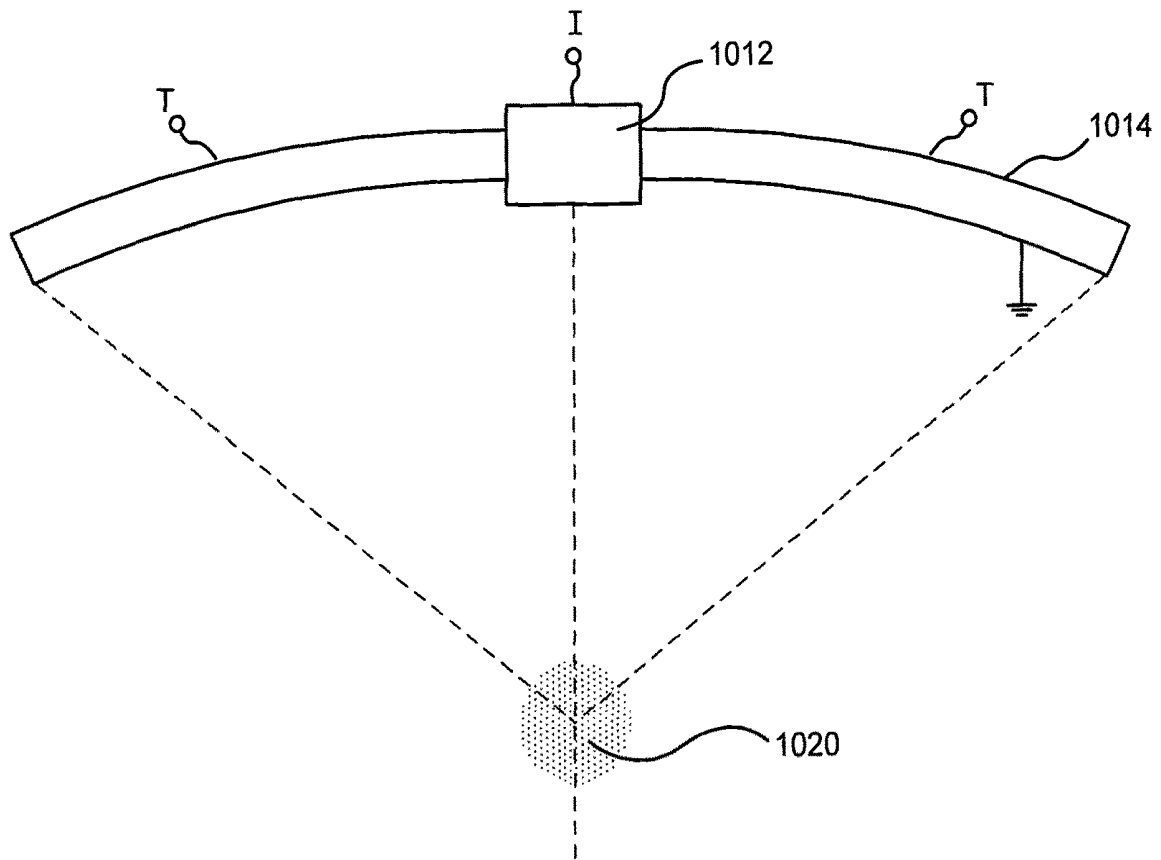

FIG. 10C

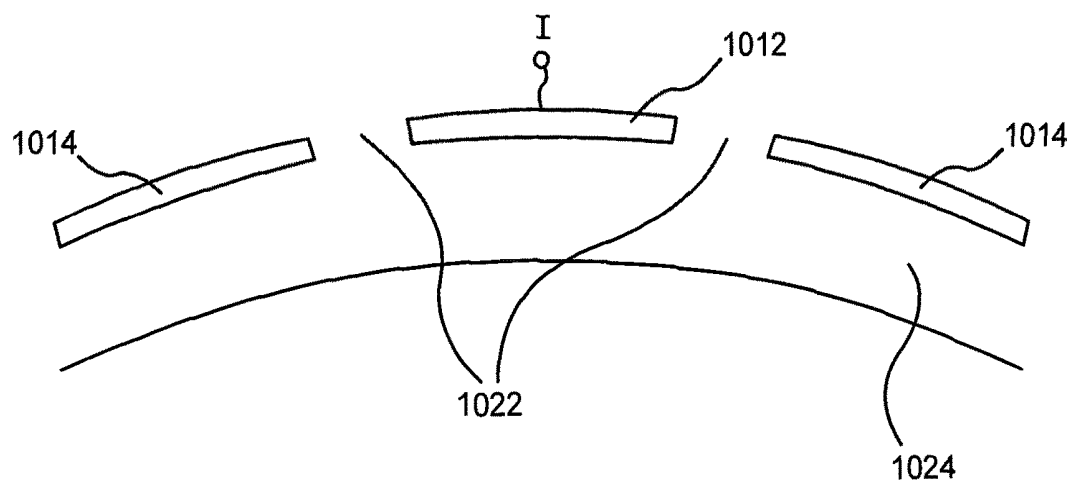

FIG. 10D

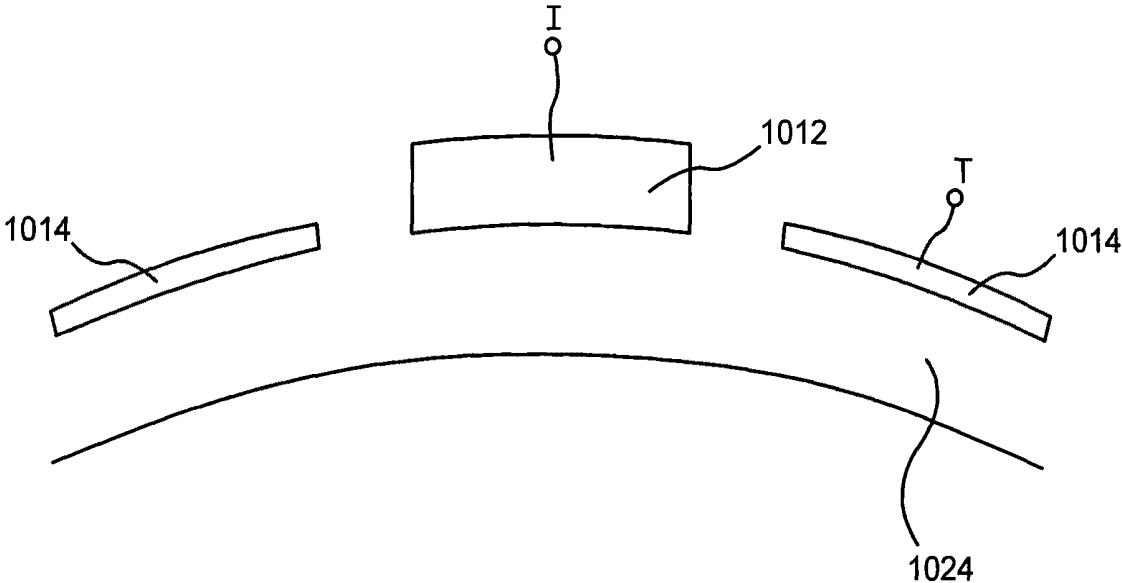

FIG. 10E

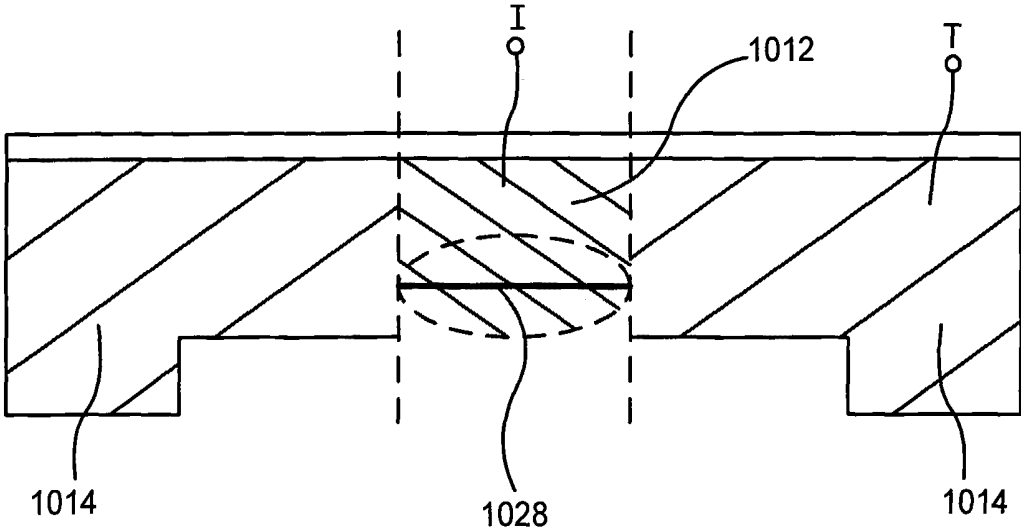

FIG. 10F

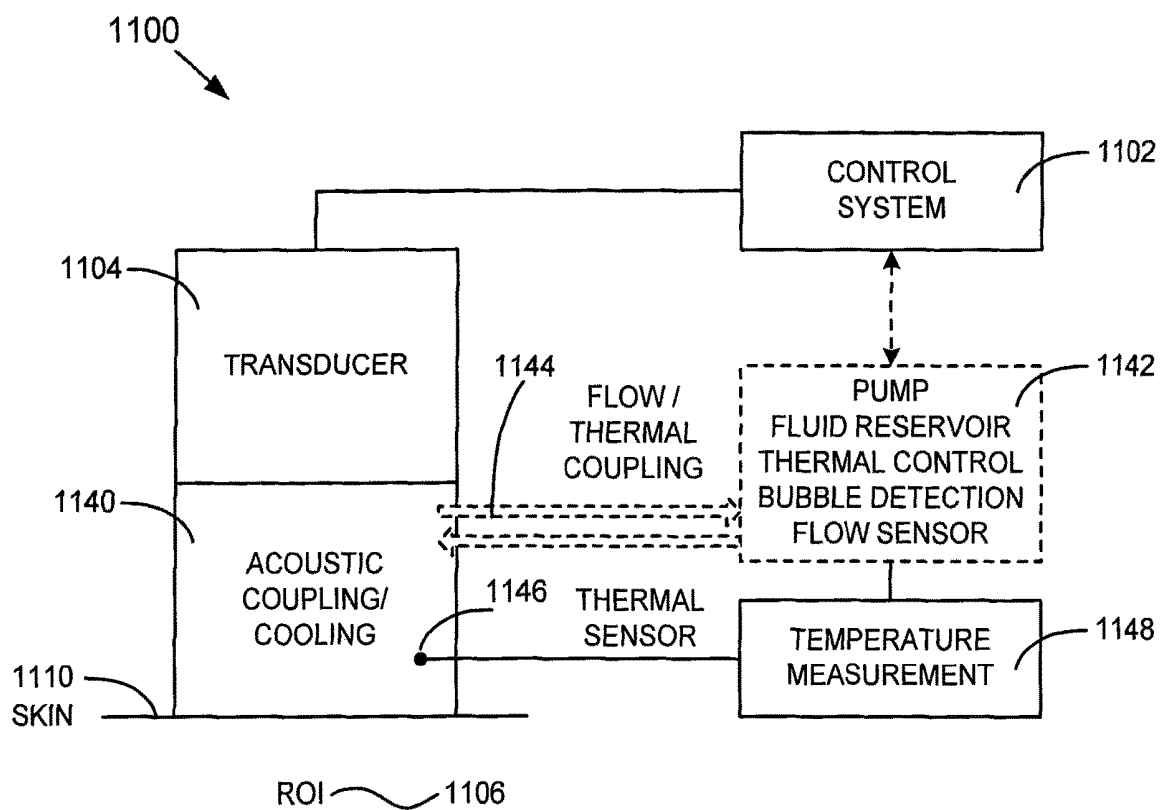

FIG. 11

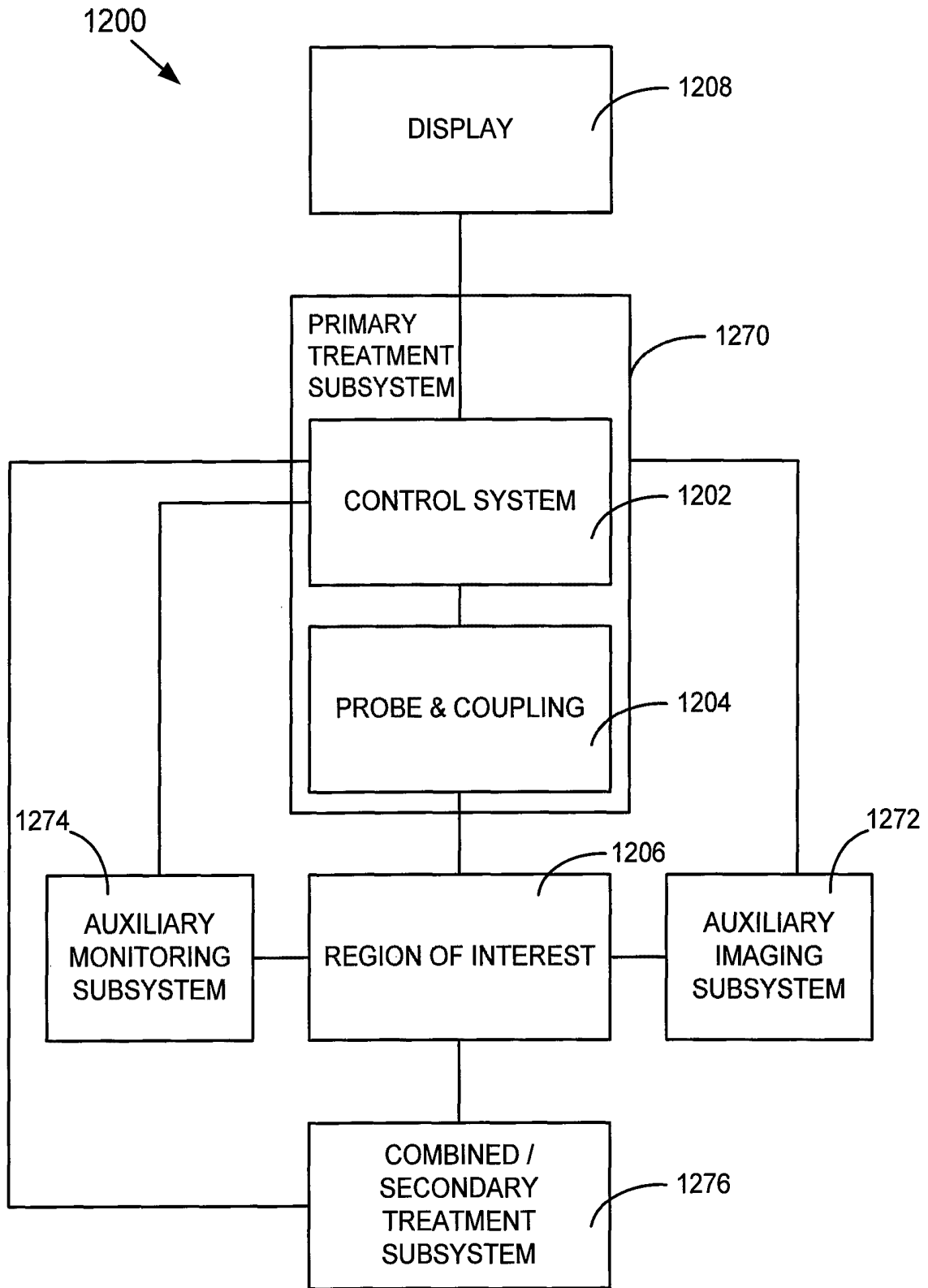

FIG. 12

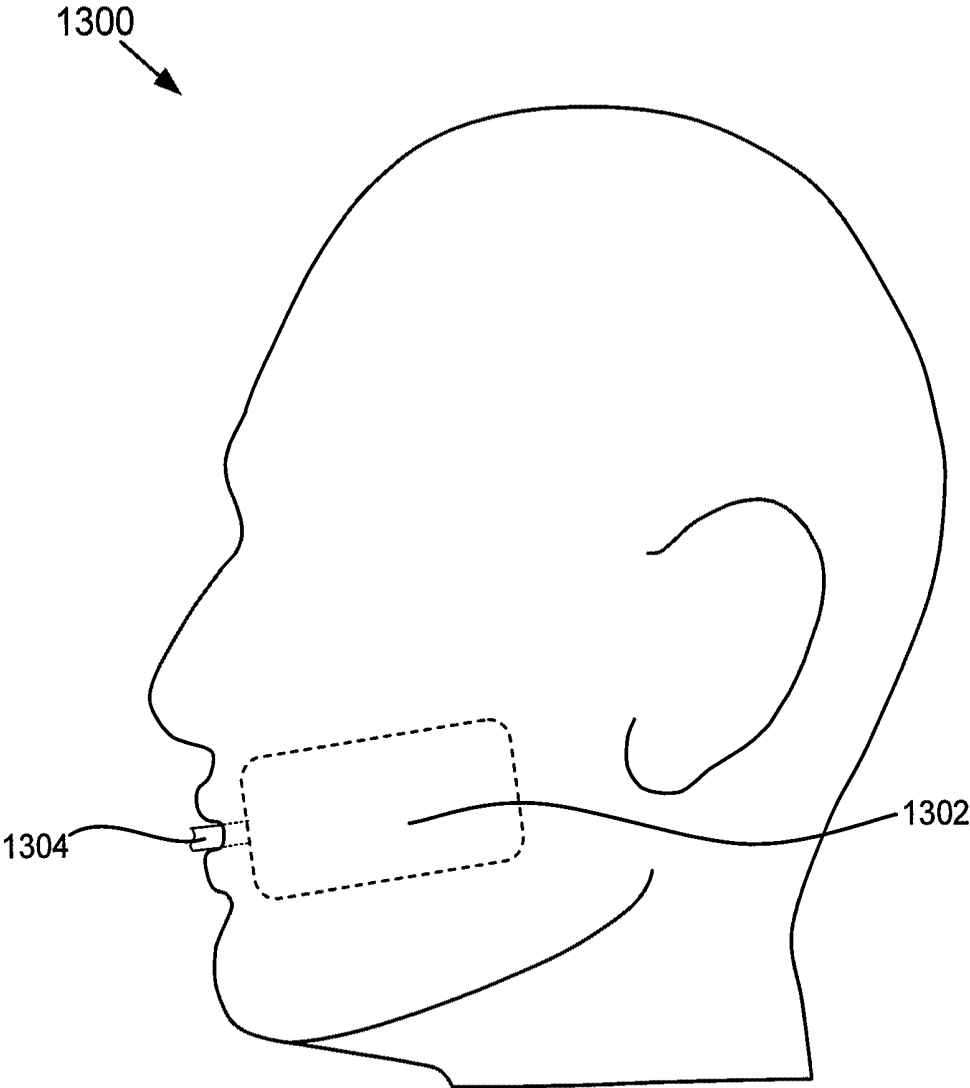

FIG. 13

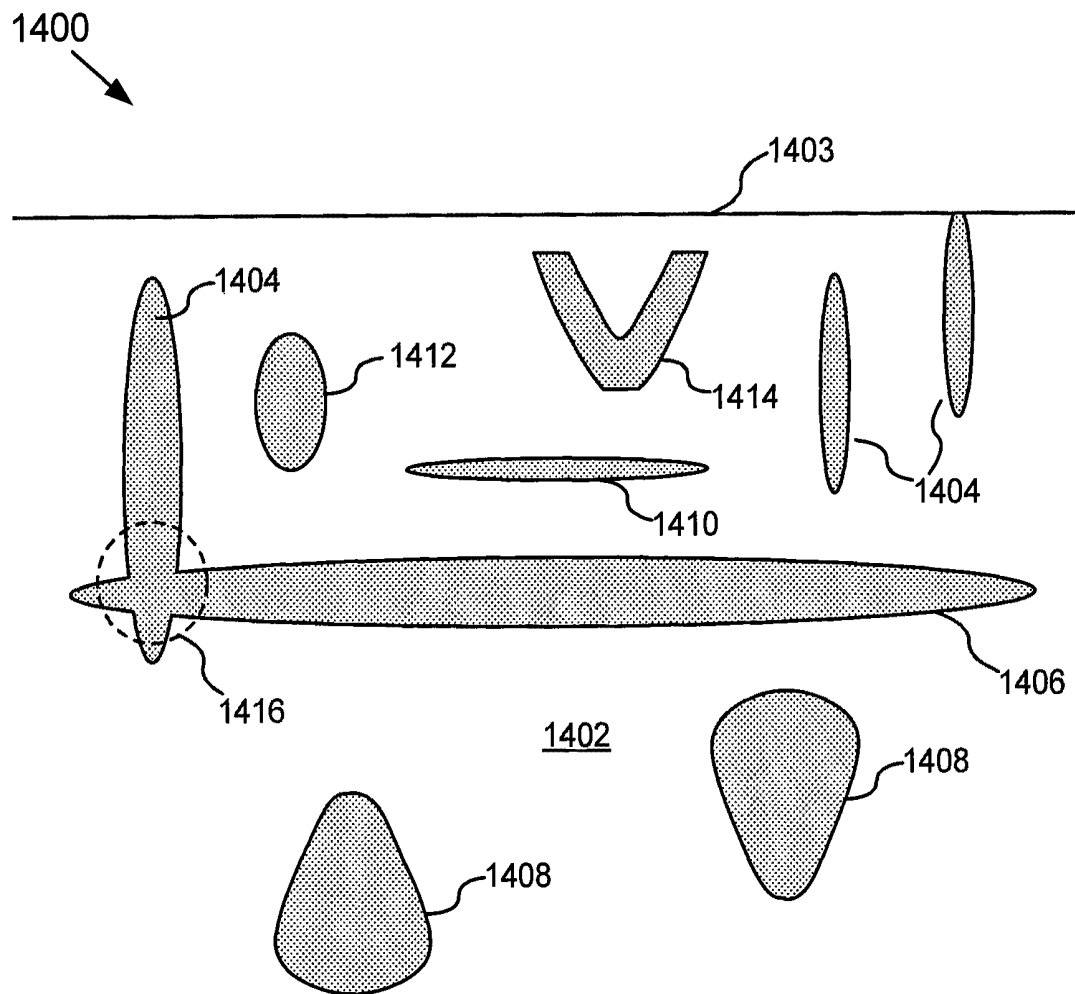

FIG. 14

Spatiotemporal Thermal Contour Growth

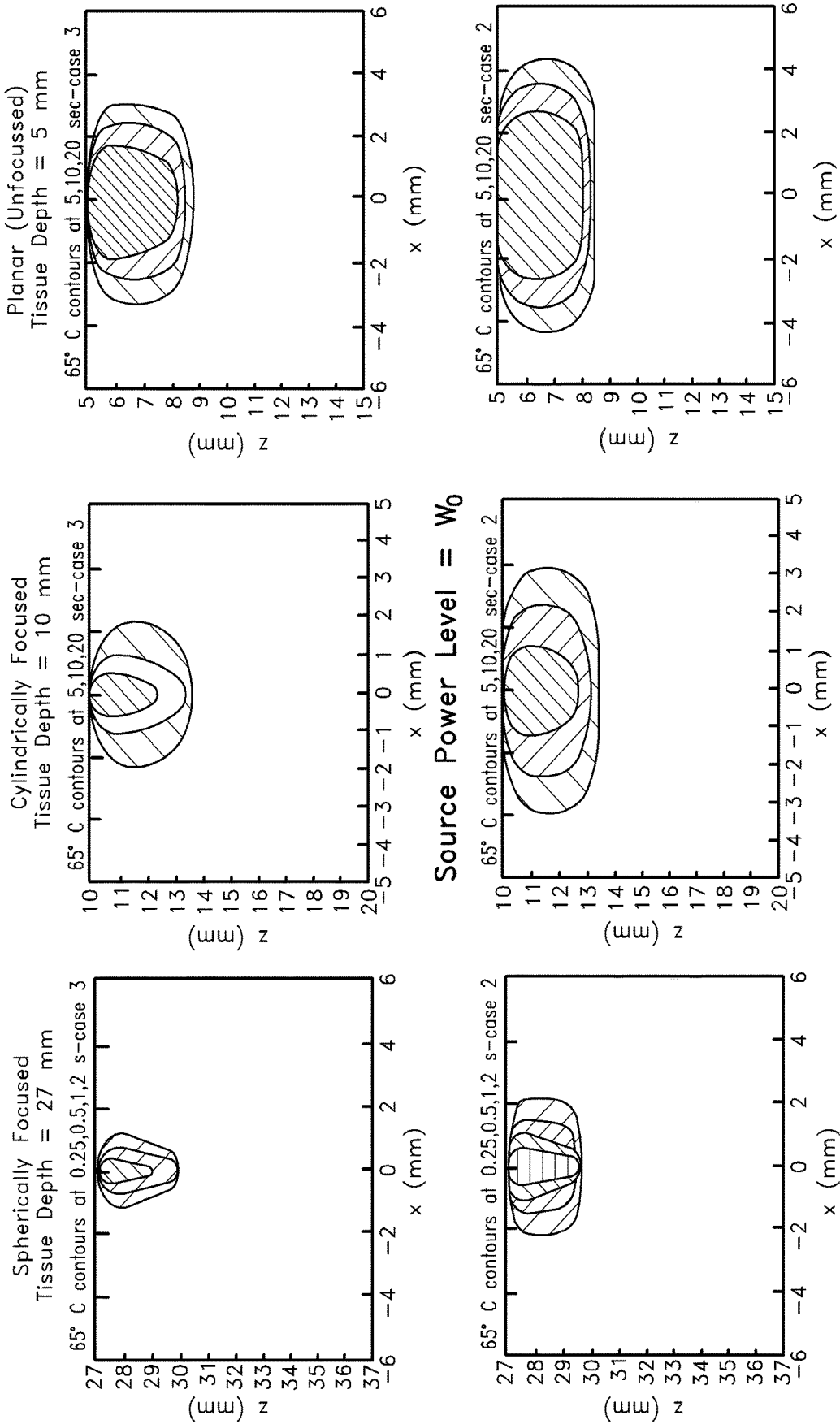

FIG. 15

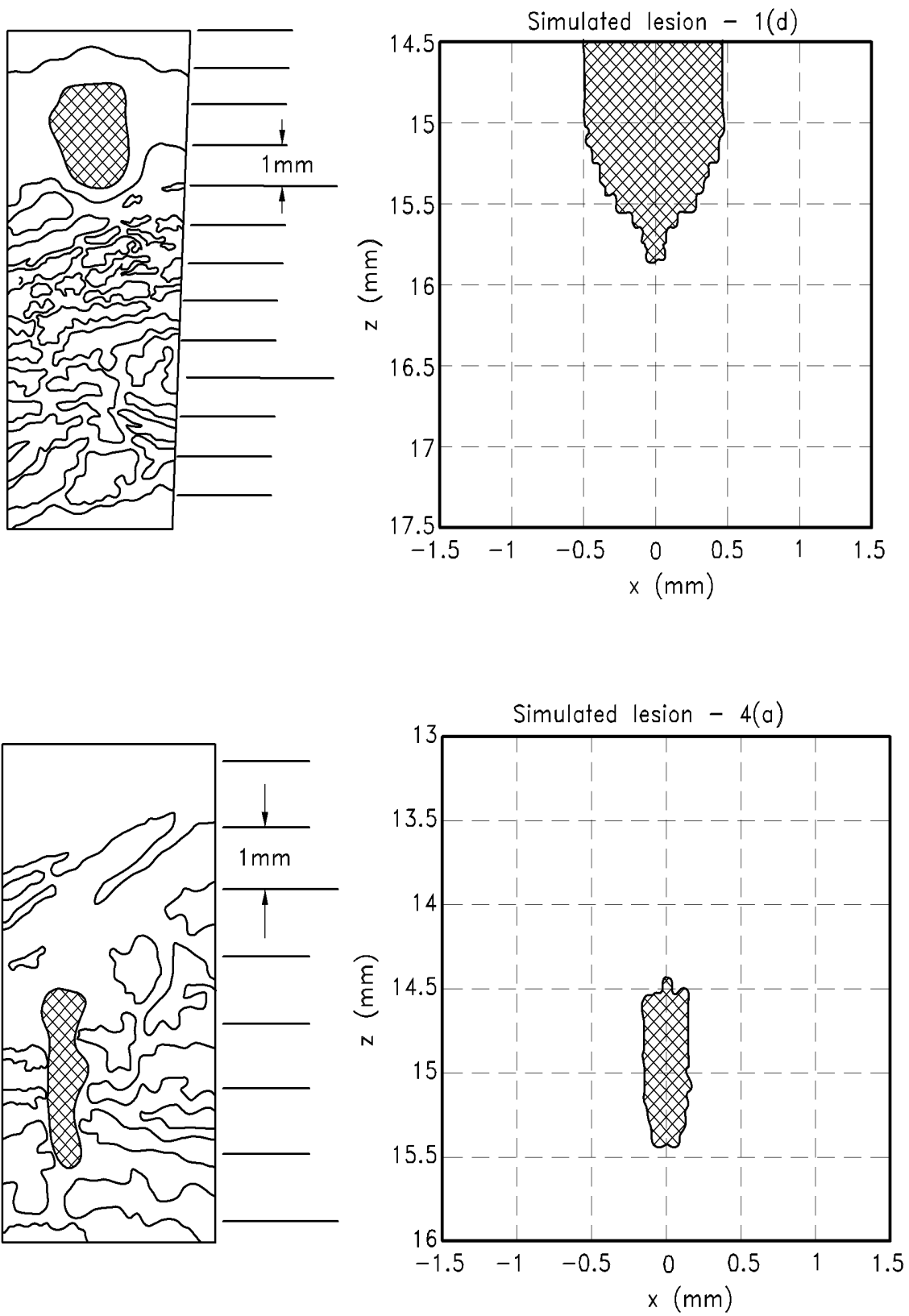

FIG. 16

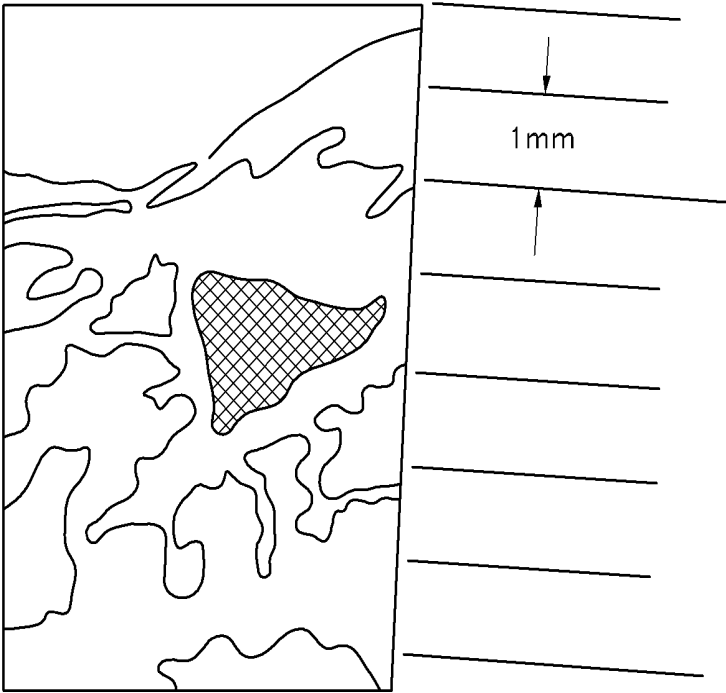
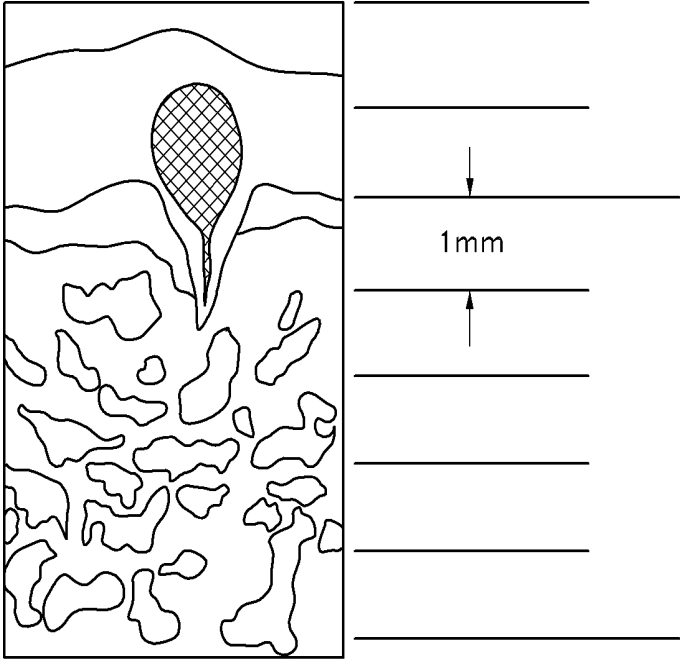

FIG. 17

## SYSTEM AND METHOD FOR NONINVASIVE SKIN TIGHTENING

### CROSS-REFERENCE TO RELATED APPLICATIONS

This Application is a continuation of U.S. application Ser. No. 15/098,139 and now issued as U.S. Pat. No. 9,974,982 entitled "System and Method For Noninvasive Skin Tightening" filed on Apr. 13, 2016, which is a continuation of U.S. application Ser. No. 13/964,820 entitled "Methods For Non-invasive Skin Tightening" filed on Aug. 12, 2013 and issued as U.S. Pat. No. 9,320,537, which is a continuation of U.S. application Ser. No. 12/028,636 entitled "Method and System for Noninvasive Face Lifts and Deep Tissue Tightening" filed on Feb. 8, 2008 and issued as U.S. Pat. No. 8,535,228 on Sep. 17, 2013, which is a continuation-in-part of U.S. application Ser. No. 11/163,151 entitled "Method and System for Noninvasive Face Lifts and Deep Tissue Tightening" filed on Oct. 6, 2005, now abandoned, which in turn claims priority to U.S. Provisional Application No. 60/616,755 entitled "Method and System for Noninvasive Face Lifts and Deep Tissue Tightening" filed on Oct. 6, 2004, each of which is incorporated by reference in its entirety. Further, U.S. application Ser. No. 12/028,636 is a continuation-in-part of U.S. application Ser. No. 11/163,148 entitled "Method and System for Controlled Thermal Injury of Human Superficial Tissue" filed on Oct. 6, 2005, now abandoned, which in turn claims priority to U.S. Provisional Application No. 60/616,754 entitled "Method and System for Controlled Thermal Injury of Human Superficial Tissue" filed on Oct. 6, 2004, each of which is incorporated by reference in its entirety. Any and all priority claims identified in the Application Data Sheet, or any correction thereto, are hereby incorporated by reference under 37 CFR 1.57.

### BACKGROUND

#### Field of the Invention

The present invention relates to ultrasound therapy and imaging systems, and in particular to a method and system for noninvasive face lifts and deep tissue tightening.

#### Background of the Invention

Coarse sagging of the skin and facial musculature occurs gradually over time due to gravity and chronic changes in connective tissue generally associated with aging. Invasive surgical treatment to tighten such tissues is common, for example by facelift procedures. In these treatments for connective tissue sagging, a portion of the tissue is usually removed, and sutures or other fasteners are used to suspend the sagging tissue structures. On the face, the Superficial Muscular Aponeurosis System (SMAS) forms a continuous layer superficial to the muscles of facial expression and beneath the skin and subcutaneous fat. Conventional face lift operations involve suspension of the SMAS through such suture and fastener procedures.

No present procedures have been developed yet, which provide the combination of targeted, precise, local heating to a specified temperature region capable of inducing ablation (thermal injury) to underlying skin and subcutaneous fat. Attempts have included the use of radio frequency (RF) devices that have been used to produce heating and shrinkage of skin on the face with some limited success as a non-invasive alternative to surgical lifting procedures. How-

ever, RF is a dispersive form of energy deposition. RF energy is impossible to control precisely within the heated tissue volume and depth, because resistive heating of tissues by RF energy occurs along the entire path of electrical conduction through tissues. Another restriction of RF energy for non-invasive tightening of the SMAS is unwanted destruction of the overlying fat and skin layers. The electric impedance to RF within fat, overlying the suspensory connective structures intended for shrinking, leads to higher temperatures in the fat than in the target suspensory structures. Similarly, mid-infrared lasers and other light sources have been used to non-invasively heat and shrink connective tissues of the dermis, again with limited success. However, light is not capable of non-invasive treatment of SMAS because light does not penetrate deeply enough to produce local heating there. Below a depth of approximately 1 mm, light energy is multiply scattered and cannot be focused to achieve precise local heating.

### SUMMARY OF THE INVENTION

A method and system for noninvasive face lifts and deep tissue tightening are provided. An exemplary method and treatment system are configured for the imaging, monitoring, and thermal injury to treat the SMAS region. In accordance with an exemplary embodiment, the exemplary method and system are configured for treating the SMAS region by first, imaging of the region of interest for localization of the treatment area and surrounding structures, second, delivery of ultrasound energy at a depth, distribution, timing, and energy level to achieve the desired therapeutic effect, and third to monitor the treatment area before, during, and after therapy to plan and assess the results and/or provide feedback.

In accordance with an exemplary embodiment, an exemplary treatment system comprises an imaging/therapy probe, a control system and display system. The imaging/therapy probe can comprise various probe and/or transducer configurations. For example, the probe can be configured for a combined dual-mode imaging/therapy transducer, coupled or co-housed imaging/therapy transducers, or simply a therapy probe and an imaging probe. The control system and display system can also comprise various configurations for controlling probe and system functionality, including for example a microprocessor with software and a plurality of input/output devices, a system for controlling electronic and/or mechanical scanning and/or multiplexing of transducers, a system for power delivery, systems for monitoring, systems for sensing the spatial position of the probe and/or transducers, and systems for handling user input and recording treatment results, among others.

In accordance with an exemplary embodiment, ultrasound imaging can be utilized for safety purposes, such as to avoid injuring vital structures such as the facial nerve (motor nerve), parotid gland, facial artery, and trigeminal nerve (for sensory functions) among others. For example, ultrasound imaging can be used to identify SMAS as the superficial layer well defined by echoes overlying the facial muscles. Such muscles can be readily seen and better identified by moving them, and their image may be further enhanced via signal and image processing.

In accordance with an exemplary embodiment, ultrasound therapy via focused ultrasound, an array of foci, a locus of foci, a line focus, and/or diffraction patterns from single element, multiple elements, annular array, one-, two-, or three-dimensional arrays, broadband transducers, and/or combinations thereof, with or without lenses, acoustic com-

ponents, mechanical and/or electronic focusing are utilized to treat the SMAS region at fixed and/or variable depth or dynamically controllable depths and positions.

In accordance with another exemplary embodiment, a therapeutic treatment method and system for controlled thermal injury of human superficial tissue is based on the ability to controllably create thermal lesions of a variable shape, size, and depth through precise spatial and temporal control of acoustic energy deposition. This system and method for controlled thermal injury can be used to complete various procedures such as face lifts and deep tissue tightening described herein. In accordance with an exemplary embodiment, an exemplary therapeutic treatment system includes a control system and a probe system that can facilitate treatment planning, controlling and/or delivering of acoustic energy, and/or monitoring of treatment conditions to a region of interest. As a result, the ability to controllably produce conformal lesions of thermal injury in superficial human tissue can be realized.

In accordance with another exemplary embodiment, a treatment method can enable the regions of thermal injury to comprise controlled conformal shapes and sizes and allow the tissue to be destroyed (ablated) in a controlled spatial and temporal manner. For example, the thermal lesions may be suitably and selectively created with narrow or wide lateral extent, long or short axial length, and/or deep or shallow placement, including up to the tissue outer surface. Moreover, separate islands of destruction may also be created over part or whole of the tissue region-of-interest, and/or contiguous or overlapping structures may be produced out of discrete lesions.

In accordance with other exemplary embodiments of the present invention, exemplary methods can comprise scanning over part or whole of the region-of-interest to produce contiguous thermal injury. The conformal lesions can be achieved not only through the independent selection and control of transducer acoustic energy spatial distribution, such as selection of transducer configuration and placement, but also through temporal control, such as through drive amplitude levels, frequency/waveform selection, and timing sequences that can be adjusted and optimized to control thermal ablation of tissue. In addition, the temperature at the acoustic coupling interface can be controlled, thus further enabling another exemplary method of lesion formation control.

#### BRIEF DESCRIPTION OF THE DRAWINGS

The subject matter of the invention is particularly pointed out in the concluding portion of the specification. The invention, however, both as to organization and method of operation, may best be understood by reference to the following description taken in conjunction with the accompanying drawing figures, in which like parts may be referred to by like numerals:

FIG. 1 illustrates a block diagram of a treatment system in accordance with an exemplary embodiment of the present invention;

FIGS. 2A-2F illustrates schematic diagrams of an ultrasound imaging/therapy and monitoring system for treating the SMAS layer in accordance with various exemplary embodiments of the present invention;

FIGS. 3A and 3B illustrate block diagrams of an exemplary control system in accordance with exemplary embodiments of the present invention;

FIGS. 4A and 4B illustrate block diagrams of an exemplary probe system in accordance with exemplary embodiments of the present invention;

FIG. 5 illustrates a cross-sectional diagram of an exemplary transducer in accordance with an exemplary embodiment of the present invention;

FIGS. 6A and 6B illustrate cross-sectional diagrams of an exemplary transducer in accordance with exemplary embodiments of the present invention;

FIG. 7 illustrates exemplary transducer configurations for ultrasound treatment in accordance with various exemplary embodiments of the present invention;

FIGS. 8A and 8B illustrate cross-sectional diagrams of an exemplary transducer in accordance with another exemplary embodiment of the present invention;

FIG. 9 illustrates an exemplary transducer configured as a two-dimensional array for ultrasound treatment in accordance with an exemplary embodiment of the present invention;

FIGS. 10A-10F illustrate cross-sectional diagrams of exemplary transducers in accordance with other exemplary embodiments of the present invention;

FIG. 11 illustrates a schematic diagram of an acoustic coupling and cooling system in accordance with an exemplary embodiment of the present invention;

FIG. 12 illustrates a block diagram of a treatment system comprising an ultrasound treatment subsystem combined with additional subsystems and methods of treatment monitoring and/or treatment imaging as well as a secondary treatment subsystem in accordance with an exemplary embodiment of the present invention;

FIG. 13 illustrates a schematic diagram with imaging, therapy, or monitoring being provided with one or more active or passive oral inserts in accordance with an exemplary embodiment of the present invention;

FIG. 14 illustrates a cross sectional diagram of a human superficial tissue region of interest including a plurality of lesions of controlled thermal injury in accordance with an exemplary embodiment of the present invention;

FIG. 15 illustrates an exemplary diagram of simulation results for various spatially controlled configurations in accordance with exemplary embodiments of the present invention;

FIG. 16 illustrates an exemplary diagram of simulation results of a pair of lesioning and simulation results in accordance with the present invention; and

FIG. 17 illustrates another exemplary diagram of simulation results of a pair of lesioning results in accordance with the present invention.

#### DETAILED DESCRIPTION

The present invention may be described herein in terms of various functional components and processing steps. It should be appreciated that such components and steps may be realized by any number of hardware components configured to perform the specified functions. For example, the present invention may employ various medical treatment devices, visual imaging and display devices, input terminals and the like, which may carry out a variety of functions under the control of one or more control systems or other control devices. In addition, the present invention may be practiced in any number of medical contexts and that the exemplary embodiments relating to a method and system for noninvasive face lift and deep tissue tightening as described herein are merely indicative of exemplary applications for the invention. For example, the principles, features and

methods discussed may be applied to any SMAS-like muscular fascia, such as platysma, temporal fascia, and/or occipital fascia, or any other medical application.

Further, various aspects of the present invention may be suitably applied to other applications. The system and method of the present invention may also be used for controlled thermal injury of various tissue. Certain exemplary methods for controlled thermal injury to various tissues are disclosed in co-pending U.S. patent application Ser. No. 11/163,148 entitled "Method and System for Controlled Thermal Injury of Human Superficial Tissue" filed on Oct. 5, 2005 to which priority is claimed and which is incorporated herein by reference in its entirety as well as the provisional application to which that application claims priority to (U.S. Provisional Application No. 60/616,754 entitled "Method and System for Controlled Thermal Injury of Human Superficial Tissue").

In accordance with various aspects of the present invention, a method and system for noninvasive face lifts and deep tissue tightening are provided. For example, in accordance with an exemplary embodiment, with reference to FIG. 1, an exemplary treatment system 100 configured to treat a region of interest 106 comprises a control system 102, an imaging/therapy probe with acoustic coupling 104, and a display system 108. Control system 102 and display system 108 can comprise various configurations for controlling probe 102 and overall system 100 functionality, such as, for example, a microprocessor with software and a plurality of input/output devices, system and devices for controlling electronic and/or mechanical scanning and/or multiplexing of transducers, a system for power delivery, systems for monitoring, systems for sensing the spatial position of the probe and/or transducers, and/or systems for handling user input and recording treatment results, among others. Imaging/therapy probe 104 can comprise various probe and/or transducer configurations. For example, probe 104 can be configured for a combined dual-mode imaging/therapy transducer, coupled or co-housed imaging/therapy transducers, or simply a separate therapy probe and an imaging probe.

In accordance with an exemplary embodiment, treatment system 100 is configured for treating the SMAS region by first, imaging of region of interest 106 for localization of the treatment area and surrounding structures, second, delivery of ultrasound energy at a depth, distribution, timing, and energy level to achieve the desired therapeutic effect, and third to monitor the treatment area before, during, and after therapy to plan and assess the results and/or provide feedback. According to another exemplary embodiment of the present invention, treatment system 100 is configured for controlled thermal injury of human superficial tissue based on treatment system 100's ability to controllably create thermal lesions of conformally variable shape, size, and depth through precise spatial and temporal control of acoustic energy deposition.

As to the treatment of the SMAS region, connective tissue can be permanently tightened by thermal treatment to temperatures about 60 degrees C. or higher. Upon ablating, collagen fibers shrink immediately by approximately 30% of their length. The shrunken fibers can produce tightening of the tissue, wherein the shrinkage should occur along the dominant direction of the collagen fibers. Throughout the body, collagen fibers are laid down in connective tissues along the lines of chronic stress (tension). On the aged face, the collagen fibers of the SMAS region are predominantly oriented along the lines of gravitational tension. Shrinkage of these fibers results in tightening of the SMAS in the

direction desired for correction of laxity and sagging due to aging. The treatment comprises the ablation of specific regions of the SMAS region and similar suspensory connective tissues.

In addition, the SMAS region varies in depth and thickness at different locations, e.g., between 0.5 mm to 5 mm or more. On the face, important structures such as nerves, parotid gland, arteries and veins are present over, under or near the SMAS region. Tightening of the SMAS in certain locations, such as the preauricular region associated with sagging of the cheek to create jowls, the frontal region associated with sagging brows, mandibular region associated with sagging neck, can be conducted. Treating through localized heating of regions of the SMAS or other suspensory subcutaneous connective tissue structures to temperatures of about 60-90° C., without significant damage to overlying or distal/underlying tissue, i.e., proximal tissue, as well as the precise delivery of therapeutic energy to SMAS regions, and obtaining feedback from the region of interest before, during, and after treatment can be suitably accomplished through treatment system 100.

To further illustrate an exemplary method and system 200, with reference to FIG. 2, imaging of a region of interest 206, such as by imaging a region 222 and displaying images 224 of the region of interest 206 on a display 208, to facilitate localization of the treatment area and surrounding structures can initially be conducted. Next, delivery of ultrasound energy 220 at a suitably depth, distribution, timing, and energy level to achieve the desired therapeutic effect of thermal injury or ablation to treat SMAS region 216 can be suitably provided by probe 204 through control by control system 202. Monitoring of the treatment area and surrounding structures before, during, and after therapy, i.e., before, during, and after the delivery of ultrasound energy to SMAS region 216, can be provided to plan and assess the results and/or provide feedback to control system 202 and a system user.

Ultrasound imaging and providing of images 224 can facilitate safe targeting of the SMAS layer 216. For example, with reference to FIG. 2B, specific targeting for the delivery of energy can be better facilitated to avoid heating vital structures such as the facial nerve (motor nerve) 234, parotid gland (which makes saliva) 236, facial artery 238, and trigeminal nerve (for sensory functions) 232 among other regions. Further, use of imaging with targeted energy delivery to provide a limited and controlled depth of treatment can minimize the chance of damaging deep structures, such as for example, the facial nerve that lies below the parotid, which is typically 10 mm thick.

In accordance with an exemplary embodiment, with reference to FIG. 2C, ultrasound imaging of region 222 of the region of interest 206 can also be used to delineate SMAS layer 216 as the superficial, echo-dense layer overlying facial muscles 218. Such muscles can be seen via imaging region 222 by moving muscles 218, for example by extensional flexing of muscle layer 218 generally towards directions 250 and 252. Such imaging of region 222 may be further enhanced via signal and image processing. Once SMAS layer 216 is localized and/or identified, SMAS layer 216 is ready for treatment.

The delivery of ultrasound energy 220 at a suitably depth, distribution, timing, and energy level is provided by probe 204 through controlled operation by control system 202 to achieve the desired therapeutic effect of thermal injury to treat SMAS region 216. During operation, probe 204 can also be mechanically and/or electronically scanned within tissue surface region 226 to treat an extended area. In

addition, spatial control of a treatment depth **220** can be suitably adjusted in various ranges, such as between a wide range of approximately 0 to 15 mm, suitably fixed to a few discrete depths, with an adjustment limited to a fine range, e.g. approximately between 3 mm to 9 mm, and/or dynamically adjusted during treatment, to treat SMAS layer **216** that typically lies at a depth between approximately 5 mm to 7 mm. Before, during, and after the delivery of ultrasound energy to SMAS region **216**, monitoring of the treatment area and surrounding structures can be provided to plan and assess the results and/or provide feedback to control system **202** and a system user.

For example, in accordance with an exemplary embodiment, with additional reference to FIG. 2D, ultrasound imaging of region **222** can be used to monitor treatment by watching the amount of shrinkage of SMAS layer **216** in direction of areas **260** and **262**, such as in real time or quasi-real time, during and after energy delivery to region **220**. The onset of substantially immediate shrinkage of SMAS layer **216** is detectable by ultrasound imaging of region **222** and may be further enhanced via image and signal processing. The monitoring of such shrinkage can be ideal because it can confirm the intended therapeutic goal of noninvasive lifting and tissue tightening; in addition, such monitoring may be used for system feedback. In addition to image monitoring, additional treatment parameters that can be suitably monitored in accordance with various other exemplary embodiments may include temperature, video, profilometry, strain imaging and/or gauges or any other suitable spatial, temporal and/or other tissue parameters.

For example, in accordance with an exemplary embodiment of the present invention, with additional reference to FIG. 2E, an exemplary monitoring method and system **200** may suitably monitor the temperature profile or other tissue parameters of the region of interest **206**, such as attenuation or speed of sound of treatment region **222** and suitably adjust the spatial and/or temporal characteristics and energy levels of ultrasound therapy transducer probe **204**. The results of such monitoring techniques may be indicated on display **208** in various manners, such as, for example, by way of one-, two-, or three-dimensional images of monitoring results **270**, or may comprise an indicator **272**, such as a success, fail and/or completed/done type of indication, or combinations thereof.

In accordance with another exemplary embodiment, with reference to FIG. 2F, the targeting of particular region **220** within SMAS layer **216** can be suitably be expanded within region of interest **206** to include a combination of tissues, such as skin **210**, dermis **212**, fat/adipose tissue **214**, SMAS/muscular fascia/and/or other suspensory tissue **216**, and muscle **218**. Treatment of a combination of such tissues and/or fascia may be treated including at least one of SMAS layer **216** or other layers of muscular fascia in combination with at least one of muscle tissue, adipose tissue, SMAS and/or other muscular fascia, skin, and dermis, can be suitably achieved by treatment system **200**. For example, treatment of SMAS layer **216** may be performed in combination with treatment of dermis **280** by suitable adjustment of the spatial and temporal parameters of probe **204** within treatment system **200**.

In accordance with various aspects of the present invention, a therapeutic treatment method and system for controlled thermal injury of human superficial tissue to effectuate face lifts, deep tissue tightening, and other procedures is based on the ability to controllably create thermal lesions of conformally variable shape, size, and depth through precise spatial and temporal control of acoustic energy

deposition. With reference to FIG. 1, in accordance with an exemplary embodiment, an exemplary therapeutic treatment system **200** includes a control system **102** and a probe system **104** that can facilitate treatment planning, controlling and/or delivering of acoustic energy, and/or monitoring of treatment conditions to a region of interest **106**. Region-of-interest **106** is configured within the human superficial tissue comprising from just below the tissue outer surface to approximately 30 mm or more in depth.

Therapeutic treatment system **100** is configured with the ability to controllably produce conformal lesions of thermal injury in superficial human tissue within region of interest **106** through precise spatial and temporal control of acoustic energy deposition, i.e., control of probe **104** is confined within selected time and space parameters, with such control being independent of the tissue. In accordance with an exemplary embodiment, control system **102** and probe system **104** can be suitably configured for spatial control of the acoustic energy by controlling the manner of distribution of the acoustical energy. For example, spatial control may be realized through selection of the type of one or more transducer configurations insonifying region of interest **106**, selection of the placement and location of probe system **104** for delivery of acoustical energy relative to region-of-interest **106**, e.g., probe system **104** being configured for scanning over part or whole of region-of-interest **106** to produce contiguous thermal injury having a particular orientation or otherwise change in distance from region-of-interest **106**, and/or control of other environment parameters, e.g., the temperature at the acoustic coupling interface can be controlled, and/or the coupling of probe **104** to human tissue. In addition to the spatial control parameters, control system **102** and probe system **104** can also be configured for temporal control, such as through adjustment and optimization of drive amplitude levels, frequency/waveform selections, e.g., the types of pulses, bursts or continuous waveforms, and timing sequences and other energy drive characteristics to control thermal ablation of tissue. The spatial and/or temporal control can also be facilitated through open-loop and closed-loop feedback arrangements, such as through the monitoring of various spatial and temporal characteristics. As a result, control of acoustical energy within six degrees of freedom, e.g., spatially within the X, Y and Z domain, as well as the axis of rotation within the XY, YZ and XZ domains, can be suitably achieved to generate conformal lesions of variable shape, size and orientation.

For example, through such spatial and/or temporal control, an exemplary treatment system **100** can enable the regions of thermal injury to possess arbitrary shape and size and allow the tissue to be destroyed (ablated) in a controlled manner. With reference to FIG. 14, one or more thermal lesions may be created within a tissue region of interest **1400**, with such thermal lesions having a narrow or wide lateral extent, long or short axial length, and/or deep or shallow placement, including up to a tissue outer surface **1403**. For example, cigar shaped lesions may be produced in a vertical disposition **1404** and/or horizontal disposition **1406**. In addition, raindrop-shaped lesions **1408**, flat planar lesions **1410**, round lesions **1412** and/or other v-shaped/ellipsoidal lesions **1414** may be formed, among others. For example, mushroom-shaped lesion **1420** may be provided, such as through initial generation of an initial round or cigar-shaped lesion **1422**, with continued application of ablative ultrasound resulting in thermal expansion to further generate a growing lesion **1424**, such thermal expansion being continued until raindrop-shaped lesion **1420** is

achieved. The plurality of shapes can also be configured in various sizes and orientations, e.g., lesions **1408** could be rotationally oriented clockwise or counterclockwise at any desired angle, or made larger or smaller as selected, all depending on spatial and/or temporal control. Moreover, separate islands of destruction, i.e., multiple lesions separated throughout the tissue region, may also be created over part of or the whole portion within tissue region-of-interest **1400**. In addition, contiguous structures and/or overlapping structures **1416** may be provided from the controlled configuration of discrete lesions. For example, a series of one or more crossed-lesions **1418** can be generated along a tissue region to facilitate various types of treatment methods.

The specific configurations of controlled thermal injury are selected to achieve the desired tissue and therapeutic effect(s). For example, any tissue effect can be realized, including but not limited to thermal and non-thermal streaming, cavitation, hydrodynamic, ablative, hemostatic, diathermic, and/or resonance-induced tissue effects. Such effects can be suitably realized at treatment depths over a range of approximately 0-30000  $\mu\text{m}$  within region of interest **200** to provide a high degree of utility.

An exemplary control system **202** and display system **208** may be configured in various manners for controlling probe and system functionality. With reference again to FIGS. **3A** and **3B**, in accordance with exemplary embodiments, an exemplary control system **300** can be configured for coordination and control of the entire therapeutic treatment process for noninvasive face lifts and deep tissue tightening. For example, control system **300** can suitably comprise power source components **302**, sensing and monitoring components **304**, cooling and coupling controls **306**, and/or processing and control logic components **308**. Control system **300** can be configured and optimized in a variety of ways with more or less subsystems and components to implement the therapeutic system for controlled thermal injury, and the embodiments in FIGS. **3A** and **3B** are merely for illustration purposes.

For example, for power sourcing components **302**, control system **300** can comprise one or more direct current (DC) power supplies **303** configured to provide electrical energy for entire control system **300**, including power required by a transducer electronic amplifier/driver **312**. A DC current sense device **305** can also be provided to confirm the level of power going into amplifiers/drivers **312** for safety and monitoring purposes.

Amplifiers/drivers **312** can comprise multi-channel or single channel power amplifiers and/or drivers. In accordance with an exemplary embodiment for transducer array configurations, amplifiers/drivers **312** can also be configured with a beamformer to facilitate array focusing. An exemplary beamformer can be electrically excited by an oscillator/digitally controlled waveform synthesizer **310** with related switching logic.

The power sourcing components can also include various filtering configurations **314**. For example, switchable harmonic filters and/or matching may be used at the output of amplifier/driver **312** to increase the drive efficiency and effectiveness. Power detection components **316** may also be included to confirm appropriate operation and calibration. For example, electric power and other energy detection components **316** may be used to monitor the amount of power going to an exemplary probe system.

Various sensing and monitoring components **304** may also be suitably implemented within control system **300**. For example, in accordance with an exemplary embodiment, monitoring, sensing and interface control components **324**

may be configured to operate with various motion detection systems implemented within transducer probe **204** to receive and process information such as acoustic or other spatial and temporal information from a region of interest. Sensing and monitoring components can also include various controls, interfacing and switches **309** and/or power detectors **316**. Such sensing and monitoring components **304** can facilitate open-loop and/or closed-loop feedback systems within treatment system **200**.

Still further, monitoring, sensing and interface control components **324** may comprise imaging systems configured for one-dimensional, two-dimensional and/or three dimensional imaging functions. Such imaging systems can comprise any imaging modality based on at least one of photography and other visual optical methods, magnetic resonance imaging (MRI), computed tomography (CT), optical coherence tomography (OCT), electromagnetic, microwave, or radio frequency (RF) methods, positron emission tomography (PET), infrared, ultrasound, acoustic, or any other suitable method of visualization, localization, or monitoring of a region-of-interest **106**. Still further, various other tissue parameter monitoring components, such as temperature measuring devices and components, can be configured within monitoring, sensing and interface control components **324**, such monitoring devices comprising any modality now known or hereinafter devised.

Cooling/coupling control systems **306** may be provided to remove waste heat from an exemplary probe **204**, provide a controlled temperature at the superficial tissue interface and deeper into tissue, and/or provide acoustic coupling from transducer probe **204** to region-of-interest **206**. Such cooling/coupling control systems **306** can also be configured to operate in both open-loop and/or closed-loop feedback arrangements with various coupling and feedback components.

Processing and control logic components **308** can comprise various system processors and digital control logic **307**, such as one or more of microcontrollers, microprocessors, field-programmable gate arrays (FPGAs), computer boards, and associated components, including firmware and control software **326**, which interfaces to user controls and interfacing circuits as well as input/output circuits and systems for communications, displays, interfacing, storage, documentation, and other useful functions. System software and firmware **326** controls all initialization, timing, level setting, monitoring, safety monitoring, and all other system functions required to accomplish user-defined treatment objectives. Further, various control switches **308** can also be suitably configured to control operation.

An exemplary transducer probe **204** can also be configured in various manners and comprise a number of reusable and/or disposable components and parts in various embodiments to facilitate its operation. For example, transducer probe **204** can be configured within any type of transducer probe housing or arrangement for facilitating the coupling of transducer to a tissue interface, with such housing comprising various shapes, contours and configurations. Transducer probe **204** can comprise any type of matching, such as for example, electric matching, which may be electrically switchable; multiplexer circuits and/or aperture/element selection circuits; and/or probe identification devices, to certify probe handle, electric matching, transducer usage history and calibration, such as one or more serial EEPROM (memories). Transducer probe **204** may also comprise cables and connectors; motion mechanisms, motion sensors and encoders; thermal monitoring sensors; and/or user control and status related switches, and indicators such as LEDs. For

example, a motion mechanism in probe **204** may be used to controllably create multiple lesions, or sensing of probe motion itself may be used to controllably create multiple lesions and/or stop creation of lesions, e.g. for safety reasons if probe **204** is suddenly jerked or is dropped. In addition, an external motion encoder arm may be used to hold the probe during use, whereby the spatial position and attitude of probe **104** is sent to the control system to help controllably create lesions. Furthermore, other sensing functionality such as profilometers or other imaging modalities may be integrated into the probe in accordance with various exemplary embodiments. Moreover, the therapy contemplated herein can also be produced, for example, by transducers disclosed in U.S. application Ser. No. 10/944,499, filed on Sep. 16, 2004, entitled METHOD AND SYSTEM FOR ULTRASOUND TREATMENT WITH A MULTI-DIRECTIONAL TRANSDUCER and U.S. application Ser. No. 10/944,500, filed on Sep. 16, 2004, and entitled SYSTEM AND METHOD FOR VARIABLE DEPTH ULTRASOUND TREATMENT, both hereby incorporated by reference.

With reference to FIGS. **4A** and **4B**, in accordance with an exemplary embodiment, a transducer probe **400** can comprise a control interface **402**, a transducer **404**, coupling components **406**, and monitoring/sensing components **408**, and/or motion mechanism **410**. However, transducer probe **400** can be configured and optimized in a variety of ways with more or less parts and components to provide ultrasound energy for controlled thermal injury, and the embodiment in FIGS. **4A** and **4B** are merely for illustration purposes. Transducer **404** can be any transducer configured to produce conformal lesions of thermal injury in superficial human tissue within a region of interest through precise spatial and temporal control of acoustic energy deposition.

Control interface **402** is configured for interfacing with control system **300** to facilitate control of transducer probe **400**. Control interface components **402** can comprise multiplexer/aperture select **424**, switchable electric matching networks **426**, serial EEPROMs and/or other processing components and matching and probe usage information **430** and interface connectors **432**.

Coupling components **406** can comprise various devices to facilitate coupling of transducer probe **400** to a region of interest. For example, coupling components **406** can comprise cooling and acoustic coupling system **420** configured for acoustic coupling of ultrasound energy and signals. Acoustic cooling/coupling system **420** with possible connections such as manifolds may be utilized to couple sound into the region-of-interest, control temperature at the interface and deeper into tissue, provide liquid-filled lens focusing, and/or to remove transducer waste heat. Coupling system **420** may facilitate such coupling through use of various coupling mediums, including air and other gases, water and other fluids, gels, solids, and/or any combination thereof, or any other medium that allows for signals to be transmitted between transducer active elements **412** and a region of interest. In addition to providing a coupling function, in accordance with an exemplary embodiment, coupling system **420** can also be configured for providing temperature control during the treatment application. For example, coupling system **420** can be configured for controlled cooling of an interface surface or region between transducer probe **400** and a region of interest and beyond by suitably controlling the temperature of the coupling medium. The suitable temperature for such coupling medium can be achieved in various manners, and utilize various feedback systems, such as thermocouples, thermistors or any other device or system configured for tempera-

ture measurement of a coupling medium. Such controlled cooling can be configured to further facilitate spatial and/or thermal energy control of transducer probe **400**.

In accordance with an exemplary embodiment, with additional reference to FIG. **11**, acoustic coupling and cooling **1140** can be provided to acoustically couple energy and imaging signals from transducer probe **1104** to and from the region of interest **1106**, to provide thermal control at the probe to region-of-interest interface **1110** and deeper into tissue, and to remove potential waste heat from the transducer probe at region **1144**. Temperature monitoring can be provided at the coupling interface via a thermal sensor **1146** to provides a mechanism of temperature measurement **1148** and control via control system **1102** and a thermal control system **1142**. Thermal control may consist of passive cooling such as via heat sinks or natural conduction and convection or via active cooling such as with peltier thermoelectric coolers, refrigerants, or fluid-based systems comprised of pump, fluid reservoir, bubble detection, flow sensor, flow channels/tubing **1144** and thermal control **1142**.

With continued reference to FIG. **4**, monitoring and sensing components **408** can comprise various motion and/or position sensors **416**, temperature monitoring sensors **418**, user control and feedback switches **414** and other like components for facilitating control by control system **300**, e.g., to facilitate spatial and/or temporal control through open-loop and closed-loop feedback arrangements that monitor various spatial and temporal characteristics.

Motion mechanism **410** can comprise manual operation, mechanical arrangements, or some combination thereof. For example, a motion mechanism **422** can be suitably controlled by control system **300**, such as through the use of accelerometers, encoders or other position/orientation devices **416** to determine and enable movement and positions of transducer probe **400**. Linear, rotational or variable movement can be facilitated, e.g., those depending on the treatment application and tissue contour surface.

Transducer **404** can comprise one or more transducers configured for treating of SMAS layers and targeted regions. Transducer **404** can also comprise one or more transduction elements and/or lenses **412**. The transduction elements can comprise a piezoelectrically active material, such as lead zirconate titanate (PZT), or any other piezoelectrically active material, such as a piezoelectric ceramic, crystal, plastic, and/or composite materials, as well as lithium niobate, lead titanate, barium titanate, and/or lead metaniobate. In addition to, or instead of, a piezoelectrically active material, transducer **404** can comprise any other materials configured for generating radiation and/or acoustical energy. Transducer **404** can also comprise one or more matching layers configured along with the transduction element such as coupled to the piezoelectrically active material. Acoustic matching layers and/or damping may be employed as necessary to achieve the desired electroacoustic response.

In accordance with an exemplary embodiment, the thickness of the transduction element of transducer **404** can be configured to be uniform. That is, a transduction element **412** can be configured to have a thickness that is substantially the same throughout. In accordance with another exemplary embodiment, the thickness of a transduction element **412** can also be configured to be variable. For example, transduction element(s) **412** of transducer **404** can be configured to have a first thickness selected to provide a center operating frequency of approximately 2 kHz to 75 MHz, such as for imaging applications. Transduction element **412** can also be configured with a second thickness selected to provide a center operating frequency of approxi-

mately 2 to 400 MHz, and typically between 4 MHz and 15 MHz for therapy application. Transducer **404** can be configured as a single broadband transducer excited with at least two or more frequencies to provide an adequate output for generating a desired response. Transducer **404** can also be configured as two or more individual transducers, wherein each transducer comprises one or more transduction element. The thickness of the transduction elements can be configured to provide center-operating frequencies in a desired treatment range. For example, transducer **404** can comprise a first transducer configured with a first transduction element having a thickness corresponding to a center frequency range of approximately 1 kHz to 3 MHz, and a second transducer configured with a second transduction element having a thickness corresponding to a center frequency of approximately 3 MHz to 100 MHz or more.

Transducer **404** may be composed of one or more individual transducers in any combination of focused, planar, or unfocused single-element, multi-element, or array transducers, including 1-D, 2-D, and annular arrays; linear, curvilinear, sector, or spherical arrays; spherically, cylindrically, and/or electronically focused, defocused, and/or lensed sources. For example, with reference to an exemplary embodiment depicted in FIG. 5, transducer **500** can be configured as an acoustic array to facilitate phase focusing. That is, transducer **500** can be configured as an array of electronic apertures that may be operated by a variety of phases via variable electronic time delays. By the term “operated,” the electronic apertures of transducer **500** may be manipulated, driven, used, and/or configured to produce and/or deliver an energy beam corresponding to the phase variation caused by the electronic time delay. For example, these phase variations can be used to deliver defocused beams, planar beams, and/or focused beams, each of which may be used in combination to achieve different physiological effects in a region of interest **510**. Transducer **500** may additionally comprise any software and/or other hardware for generating, producing and or driving a phased aperture array with one or more electronic time delays.

Transducer **500** can also be configured to provide focused treatment to one or more regions of interest using various frequencies. In order to provide focused treatment, transducer **500** can be configured with one or more variable depth devices to facilitate treatment. For example, transducer **500** may be configured with variable depth devices disclosed in U.S. patent application Ser. No. 10/944,500, entitled “System and Method for Variable Depth Ultrasound”, filed on Sep. 16, 2004, having at least one common inventor and a common Assignee as the present application, and incorporated herein by reference. In addition, transducer **500** can also be configured to treat one or more additional ROI **510** through the enabling of sub-harmonics or pulse-echo imaging, as disclosed in U.S. patent application Ser. No. 10/944,499, entitled “Method and System for Ultrasound Treatment with a Multi-directional Transducer”, filed on Sep. 16, 2004, having at least one common inventor and a common Assignee as the present application, and also incorporated herein by reference.

Moreover, any variety of mechanical lenses or variable focus lenses, e.g. liquid-filled lenses, may also be used to focus and or defocus the sound field. For example, with reference to exemplary embodiments depicted in FIGS. 6A and 6B, transducer **600** may also be configured with an electronic focusing array **604** in combination with one or more transduction elements **606** to facilitate increased flexibility in treating ROI **610**. Array **604** may be configured in a manner similar to transducer **502**. That is, array **604** can be

configured as an array of electronic apertures that may be operated by a variety of phases via variable electronic time delays, for example,  $T_1, T_2 \dots T_j$ . By the term “operated,” the electronic apertures of array **604** may be manipulated, driven, used, and/or configured to produce and/or deliver energy in a manner corresponding to the phase variation caused by the electronic time delay. For example, these phase variations can be used to deliver defocused beams, planar beams, and/or focused beams, each of which may be used in combination to achieve different physiological effects in ROI **610**.

Transduction elements **606** may be configured to be concave, convex, and/or planar. For example, in an exemplary embodiment depicted in FIG. 6A, transduction elements **606A** are configured to be concave in order to provide focused energy for treatment of ROI **610**. Additional embodiments are disclosed in U.S. patent application Ser. No. 10/944,500, entitled “Variable Depth Transducer System and Method”, and again incorporated herein by reference.

In another exemplary embodiment, depicted in FIG. 6B, transduction elements **606B** can be configured to be substantially flat in order to provide substantially uniform energy to ROI **610**. While FIGS. 6A and 6B depict exemplary embodiments with transduction elements **604** configured as concave and substantially flat, respectively, transduction elements **604** can be configured to be concave, convex, and/or substantially flat. In addition, transduction elements **604** can be configured to be any combination of concave, convex, and/or substantially flat structures. For example, a first transduction element can be configured to be concave, while a second transduction element can be configured to be substantially flat.

With reference to FIGS. 8A and 8B, transducer **404** can be configured as single-element arrays, wherein a single-element **802**, e.g., a transduction element of various structures and materials, can be configured with a plurality of masks **804**, such masks comprising ceramic, metal or any other material or structure for masking or altering energy distribution from element **802**, creating an array of energy distributions **808**. Masks **804** can be coupled directly to element **802** or separated by a standoff **806**, such as any suitably solid or liquid material.

An exemplary transducer **404** can also be configured as an annular array to provide planar, focused and/or defocused acoustical energy. For example, with reference to FIGS. 10A and 10B, in accordance with an exemplary embodiment, an annular array **1000** can comprise a plurality of rings **1012, 1014, 1016** to N. Rings **1012, 1014, 1016** to N can be mechanically and electrically isolated into a set of individual elements, and can create planar, focused, or defocused waves. For example, such waves can be centered on-axis, such as by methods of adjusting corresponding transmit and/or receive delays,  $\tau_1, \tau_2, \tau_3 \dots \tau_N$ . An electronic focus can be suitably moved along various depth positions, and can enable variable strength or beam tightness, while an electronic defocus can have varying amounts of defocusing. In accordance with an exemplary embodiment, a lens and/or convex or concave shaped annular array **1000** can also be provided to aid focusing or defocusing such that any time differential delays can be reduced. Movement of annular array **800** in one, two or three-dimensions, or along any path, such as through use of probes and/or any conventional robotic arm mechanisms, may be implemented to scan and/or treat a volume or any corresponding space within a region of interest.

Transducer **404** can also be configured in other annular or non-array configurations for imaging/therapy functions. For example, with reference to FIGS. **10C-10F**, a transducer can comprise an imaging element **1012** configured with therapy element(s) **1014**. Elements **1012** and **1014** can comprise a single-transduction element, e.g., a combined imaging/transducer element, or separate elements, can be electrically isolated **1022** within the same transduction element or between separate imaging and therapy elements, and/or can comprise standoff **1024** or other matching layers, or any combination thereof. For example, with particular reference to FIG. **10F**, a transducer can comprise an imaging element **1012** having a surface **1028** configured for focusing, defocusing or planar energy distribution, with therapy elements **1014** including a stepped-configuration lens configured for focusing, defocusing, or planar energy distribution.

With a better understanding of the various transducer structures, and with reference again to FIG. **14**, how the geometric configuration of the transducer or transducers that contributes to the wide range of lesioning effects can be better understood. For example, cigar-shaped lesions **1404** and **1406** may be produced from a spherically focused source, and/or planar lesions **1410** from a flat source. Concave planar sources and arrays can produce a “V-shaped” or ellipsoidal lesion **1414**. Electronic arrays, such as a linear array, can produce defocused, planar, or focused acoustic beams that may be employed to form a wide variety of additional lesion shapes at various depths. An array may be employed alone or in conjunction with one or more planar or focused transducers. Such transducers and arrays in combination produce a very wide range of acoustic fields and their associated benefits. A fixed focus and/or variable focus lens or lenses may be used to further increase treatment flexibility. A convex-shaped lens, with acoustic velocity less than that of superficial tissue, may be utilized, such as a liquid-filled lens, gel-filled or solid gel lens, rubber or composite lens, with adequate power handling capacity; or a concave-shaped, low profile, lens may be utilized and composed of any material or composite with velocity greater than that of tissue. While the structure of transducer source and configuration can facilitate a particular shaped lesion as suggested above, such structures are not limited to those particular shapes as the other spatial parameters, as well as the temporal parameters, can facilitate additional shapes within any transducer structure and source.

In accordance with various exemplary embodiments of the present invention, transducer **404** may be configured to provide one, two and/or three-dimensional treatment applications for focusing acoustic energy to one or more regions of interest. For example, as discussed above, transducer **404** can be suitably diced to form a one-dimensional array, e.g., transducer **602** comprising a single array of sub-transduction elements.

In accordance with another exemplary embodiment, transducer **404** may be suitably diced in two-dimensions to form a two-dimensional array. For example, with reference to FIG. **9**, an exemplary two-dimensional array **900** can be suitably diced into a plurality of two-dimensional portions **902**. Two-dimensional portions **902** can be suitably configured to focus on the treatment region at a certain depth, and thus provide respective slices **904** of the treatment region. As a result, the two-dimensional array **900** can provide a two-dimensional slicing of the image plane of a treatment region, thus providing two-dimensional treatment.

In accordance with another exemplary embodiment, transducer **404** may be suitably configured to provide three-dimensional treatment. For example, to provide three-

dimensional treatment of a region of interest, with reference again to FIG. **1**, a three-dimensional system can comprise a transducer within probe **104** configured with an adaptive algorithm, such as, for example, one utilizing three-dimensional graphic software, contained in a control system, such as control system **102**. The adaptive algorithm is suitably configured to receive two-dimensional imaging, temperature and/or treatment or other tissue parameter information relating to the region of interest, process the received information, and then provide corresponding three-dimensional imaging, temperature and/or treatment information.

In accordance with an exemplary embodiment, with reference again to FIG. **9**, an exemplary three-dimensional system can comprise a two-dimensional array **900** configured with an adaptive algorithm to suitably receive **904** slices from different image planes of the treatment region, process the received information, and then provide volumetric information **906**, e.g., three-dimensional imaging, temperature and/or treatment information. Moreover, after processing the received information with the adaptive algorithm, the two-dimensional array **900** may suitably provide therapeutic heating to the volumetric region **906** as desired.

In accordance with other exemplary embodiments, rather than utilizing an adaptive algorithm, such as three-dimensional software, to provide three-dimensional imaging and/or temperature information, an exemplary three-dimensional system can comprise a single transducer **404** configured within a probe arrangement to operate from various rotational and/or translational positions relative to a target region.

To further illustrate the various structures for transducer **404**, with reference to FIG. **7**, ultrasound therapy transducer **700** can be configured for a single focus, an array of foci, a locus of foci, a line focus, and/or diffraction patterns. Transducer **700** can also comprise single elements, multiple elements, annular arrays, one-, two-, or three-dimensional arrays, broadband transducers, and/or combinations thereof, with or without lenses, acoustic components, and mechanical and/or electronic focusing. Transducers configured as spherically focused single elements **702**, annular arrays **704**, annular arrays with damped regions **706**, line focused single elements **708**, 1-D linear arrays **710**, 1-D curvilinear arrays in concave or convex form, with or without elevation focusing, 2-D arrays, and 3-D spatial arrangements of transducers may be used to perform therapy and/or imaging and acoustic monitoring functions. For any transducer configuration, focusing and/or defocusing may be in one plane or two planes via mechanical focus **720**, convex lens **722**, concave lens **724**, compound or multiple lenses **726**, planar form **728**, or stepped form, such as illustrated in FIG. **10F**. Any transducer or combination of transducers may be utilized for treatment. For example, an annular transducer may be used with an outer portion dedicated to therapy and the inner disk dedicated to broadband imaging wherein such imaging transducer and therapy transducer have different acoustic lenses and design, such as illustrated in FIG. **10C-10F**.

Moreover, such transduction elements **700** may comprise a piezoelectrically active material, such as lead zirconate titanate (PZT), or any other piezoelectrically active material, such as a piezoelectric ceramic, crystal, plastic, and/or composite materials, as well as lithium niobate, lead titanate, barium titanate, and/or lead metaniobate. Transduction elements **700** may also comprise one or more matching layers configured along with the piezoelectrically active material. In addition to or instead of piezoelectrically active material, transduction elements **700** can comprise any other materials

configured for generating radiation and/or acoustical energy. A means of transferring energy to and from the transducer to the region of interest is provided.

In accordance with another exemplary embodiment, with reference to FIG. 12, an exemplary treatment system 200 can be configured with and/or combined with various auxiliary systems to provide additional functions. For example, an exemplary treatment system 1200 for treating a region of interest 1206 can comprise a control system 1202, a probe 1204, and a display 1208. Treatment system 1200 further comprises an auxiliary imaging modality 1274 and/or auxiliary monitoring modality 1272 may be based upon at least one of photography and other visual optical methods, magnetic resonance imaging (MRI), computed tomography (CT), optical coherence tomography (OCT), electromagnetic, microwave, or radio frequency (RF) methods, positron emission tomography (PET), infrared, ultrasound, acoustic, or any other suitable method of visualization, localization, or monitoring of SMAS layers within region-of-interest 1206, including imaging/monitoring enhancements. Such imaging/monitoring enhancement for ultrasound imaging via probe 1204 and control system 1202 could comprise M-mode, persistence, filtering, color, Doppler, and harmonic imaging among others; furthermore an ultrasound treatment system 1270, as a primary source of treatment, may be combined with a secondary source of treatment 1276, including radio frequency (RF), intense pulsed light (IPL), laser, infrared laser, microwave, or any other suitable energy source.

In accordance with another exemplary embodiment, with reference to FIG. 13, treatment composed of imaging, monitoring, and/or therapy to a region of interest may be further aided, augmented, and/or delivered with passive or active devices 1304 within the oral cavity. For example, if passive or active device 1304 is a second transducer or acoustic reflector acoustically coupled to the cheek lining it is possible to obtain through transmission, tomographic, or round-trip acoustic waves which are useful for treatment monitoring, such as in measuring acoustic speed of sound and attenuation, which are temperature dependent; furthermore such a transducer could be used to treat and/or image. In addition an active, passive, or active/passive object 1304 may be used to flatten the skin, and/or may be used as an imaging grid, marker, or beacon, to aid determination of position. A passive or active device 1304 may also be used to aid cooling or temperature control. Natural air in the oral cavity may also be used as passive device 1304 whereby it may be utilized to as an acoustic reflector to aid thickness measurement and monitoring function.

During operation of an exemplary treatment system, a lesion configuration of a selected size, shape, orientation is determined. Based on that lesion configuration, one or more spatial parameters are selected, along with suitable temporal parameters, the combination of which yields the desired conformal lesion. Operation of the transducer can then be initiated to provide the conformal lesion or lesions. Open and/or closed-loop feedback systems can also be implemented to monitor the spatial and/or temporal characteristics, and/or other tissue parameter monitoring, to further control the conformal lesions.

With reference to FIG. 13, a collection of simulation results, illustrating thermal lesion growth over time are illustrated. Such lesion growth was generated with a spherically focused, cylindrically focused, and planar (unfocused) source at a nominal source acoustic power level, W and twice that level, 2 W0, but any configurations of transducer can be utilized as disclosed herein. The thermal contours

indicate where the tissue reached 65° C. for different times. The contour for the cylindrically focused source is along the short axis, or so-called elevation plane. The figure highlights the different shapes of lesions possible with different power levels and source geometries. In addition, with reference to FIG. 14, a pair of lesioning and simulation results is illustrated, showing chemically stained porcine tissue photomicrographs adjacent to their simulation results. In addition, with reference to FIG. 15, another pair of lesioning results is illustrated, showing chemically stained porcine tissue photomicrographs, highlighting a tadpole shaped lesion and a wedge shaped lesion.

In summary, adjustment of the acoustic field spatial distribution via transducer type and distribution, such as size, element configuration, electronic or mechanical lenses, acoustic coupling and/or cooling, combined with adjustment of the temporal acoustic field, such as through control of transmit power level and timing, transmit frequency and/or drive waveform can facilitate the achieving of controlled thermal lesions of variable size, shape, and depths. Moreover, the restorative biological responses of the human body can further cause the desired effects to the superficial human tissue.

The present invention has been described above with reference to various exemplary embodiments. However, those skilled in the art will recognize that changes and modifications may be made to the exemplary embodiments without departing from the scope of the present invention. For example, the various operational steps, as well as the components for carrying out the operational steps, may be implemented in alternate ways depending upon the particular application or in consideration of any number of cost functions associated with the operation of the system, e.g., various of the steps may be deleted, modified, or combined with other steps. These and other changes or modifications are intended to be included within the scope of the present invention, as set forth in the following claims.

What is claimed is:

1. A method for tissue shrinkage, the method comprising: providing an ultrasound probe comprising a housing and a piezoelectric therapy transducer for treating a region of interest, wherein the piezoelectric therapy transducer is housed within the housing, wherein the region of interest comprises a collagen fiber and a muscle tissue below a skin surface; and focusing ultrasound energy from the ultrasound therapy transducer into the region of interest at a frequency of 4 MHz to 15 MHz, thereby heating the collagen fiber and the muscle tissue in the region of interest to cause shrinkage of the collagen fiber for tightening of the skin surface.
2. The method of claim 1, further comprising providing a piezoelectric ultrasound imaging transducer to image the region of interest, wherein the piezoelectric ultrasound imaging transducer is housed within the ultrasound probe.
3. The method of claim 2, wherein the piezoelectric therapy transducer comprises a single active ultrasound therapy piezoelectric element with a portion of a spherical surface with a mechanical focus at a depth under the skin surface.
4. The method of claim 3, wherein the piezoelectric therapy transducer further comprises any one of the group consisting of: a mechanical variable depth, a mechanical dynamically controllable depth, an electronic focusing, an electronic variable depth, and an electronic dynamically controllable depth.

5. The method of claim 1, wherein the collagen fiber is located in any of the group consisting of: a dermal tissue, a connective tissue, a superficial muscular aponeurosis system (SMAS), and an adipose tissue in the region of interest.

6. The method of claim 1, wherein the ultrasound probe further comprises a storage system configured for stored information, wherein said stored information is selected from the group consisting of one or more of the following: probe identification, calibration, and probe usage history.

7. The method of claim 1, wherein the collagen fiber is located in the superficial muscular aponeurosis system (SMAS) in the region of interest.

8. The method of claim 1, wherein a portion of the probe housing is configured for acoustic coupling to the skin surface and wherein the heating of the collagen fiber in the region of interest comprises heating the collagen fiber to a temperature between 60° C. to 90° C.

9. The method of claim 1, further comprising monitoring the region of interest during or after therapy to provide feedback to a control system, wherein the control system controls the ultrasound therapy transducer.

10. The method of claim 1, further comprising monitoring the region of interest during or after therapy to provide feedback to an operator.

11. The method of claim 1, wherein the transmitting ultrasound energy from the ultrasound transducer into the region of interest comprises focusing the ultrasound energy at a depth of between 3 mm to 9 mm below the skin surface.

12. A method for tissue shrinkage, the method comprising:

providing an ultrasound imaging transducer for imaging a region of interest under a skin surface;

wherein the region of interest comprises a plurality of collagen fibers in a muscular fascia;

providing a piezoelectric ultrasound therapy transducer for delivering therapeutic ultrasound energy to a region of interest under a skin surface to heat the plurality of collagen fibers in the muscular fascia with the therapeutic ultrasound energy at a temperature sufficient to shrink the plurality of collagen fibers in the muscular fascia, thereby tightening the skin surface; and

wherein the imaging transducer and the piezoelectric therapy transducer are co-housed within a single ultrasound probe.

13. The method of claim 12, wherein the piezoelectric therapy transducer is configured to deliver energy at a frequency in the range of 4 MHz to 15 MHz.

14. The method of claim 12, wherein the probe is controlled by a control system comprising a microprocessor and

a power supply, wherein the control system is configured to calibrate the ultrasound probe based on calibration data from a storage system.

15. The method of claim 14, wherein the ultrasound probe comprising a storage system wherein said stored information is selected from the group consisting of one or more of the following: probe identification, calibration, and probe usage history.

16. A method for shrinking skin tissue, the method comprising:

providing an ultrasound probe comprising a housing and a piezoelectric ultrasound therapy transducer for treating a region of interest,

wherein the region of interest comprises collagen below a skin surface; and

wherein the piezoelectric ultrasound therapy transducer comprises one of the group consisting of a spherical focus and a cylindrical focus,

wherein ultrasound energy is transmitted from the ultrasound transducer into the region of interest, thereby heating the collagen in a superficial muscular aponeurosis system (SMAS) tissue in the region of interest to cause shrinkage of the collagen for tightening of the skin surface.

17. The method of claim 16, wherein the region of interest further comprises at least one of a connective tissue, a dermis tissue, a muscular fascia, and an adipose tissue.

18. The method of claim 16, further comprising providing an imaging transducer for imaging the region of interest, wherein the imaging transducer and the therapy transducer are co-housed within the ultrasound probe, and wherein the therapy transducer is configured to deliver energy at a frequency in the range of 4 MHz to 15 MHz.

19. The method of claim 18, further comprising moving the piezoelectric ultrasound therapy transducer with a motion mechanism connected to the piezoelectric ultrasound therapy transducer, wherein the motion mechanism comprises an encoder for monitoring a position of the piezoelectric ultrasound therapy transducer on the motion mechanism in the probe housing of the ultrasound probe.

20. The method of claim 19, wherein the therapy transducer is configured to deliver energy sufficient to heat the region of interest to a temperature between 60° C. to 90° C. and wherein the ultrasound probe comprises a storage system with stored information, wherein said stored information is selected from the group consisting of one or more of: a probe identification, a calibration, and a probe usage history.

\* \* \* \* \*

专利名称(译)	系统和方法的无创皮肤收紧		
公开(公告)号	<a href="#">US10525288</a>	公开(公告)日	2020-01-07
申请号	US15/958939	申请日	2018-04-20
申请(专利权)人(译)	引导治疗系统公司		
当前申请(专利权)人(译)	引导治疗系统公司		
[标]发明人	SLAYTON MICHAEL H BARTHE PETER G MAKIN INDER RAJ S OCONNOR BRIAN D		
发明人	SLAYTON, MICHAEL H. BARTHE, PETER G. MAKIN, INDER RAJ S. O'CONNOR, BRIAN D.		
IPC分类号	A61N7/02 A61B8/00 A61B8/12 A61B5/00 A61B8/08 A61B17/32 G01S15/89 A61N7/00 A61H23/02		
CPC分类号	A61N7/02 A61B8/08 G01S15/8909 A61B8/483 A61H23/0245 A61B8/0858 A61B8/4483 A61B5/682 A61B5/6842 A61N7/00 A61B8/12 A61B8/546 A61B2017/320069 A61H2201/5007 A61N2007/0034 A61B8/4455 A61N2007/0008 A61B8/4281 A61H2230/50 G01S15/899		
优先权	60/616755 2004-10-06 US 60/616754 2004-10-06 US		
其他公开文献	US20180236273A1		
外部链接	<a href="#">Espacenet</a>		

摘要(译)

公开了一种用于非侵入性面部提拉和深层组织拉紧的方法和系统。示例性的方法和治疗系统被配置用于成像，监测和热损伤以治疗SMAS区域。根据一个示例性实施例，该示例性方法和系统被配置为通过以下方式治疗SMAS区域：首先，对感兴趣区域成像以定位治疗区域和周围结构，其次，在深度处传递超声能量，进行分布，时间，能量水平以达到所需的治疗效果，第三步是在治疗之前，期间和之后监测治疗区域，以计划和评估结果和/或提供反馈。

