

US010499986B2

(12) **United States Patent**
Gelbart et al.

(10) **Patent No.:** **US 10,499,986 B2**
(45) **Date of Patent:** **Dec. 10, 2019**

(54) **MEDICAL DEVICE FOR USE IN BODILY LUMENS, FOR EXAMPLE AN ATRIUM**

(71) Applicant: **Kardium Inc.**, Burnaby (CA)

(72) Inventors: **Daniel Gelbart**, Vancouver (CA);
Douglas Wayne Goertzen, New Westminster (CA); **Fernando Luis de Souza Lopes**, Delta (CA)

(73) Assignee: **KARDIUM INC.**, Burnaby (CA)

(*) Notice: Subject to any disclaimer, the term of this patent is extended or adjusted under 35 U.S.C. 154(b) by 346 days.

(21) Appl. No.: **15/663,077**

(22) Filed: **Jul. 28, 2017**

(65) **Prior Publication Data**
US 2017/0333124 A1 Nov. 23, 2017

Related U.S. Application Data
(60) Continuation of application No. 14/521,692, filed on Oct. 23, 2014, now Pat. No. 9,750,569, which is a (Continued)

(51) **Int. Cl.**
A61B 18/14 (2006.01)
A61B 5/06 (2006.01)
(Continued)

(52) **U.S. Cl.**
CPC **A61B 18/1492** (2013.01); **A61B 5/06** (2013.01); **A61B 5/065** (2013.01); **A61B 5/4875** (2013.01);
(Continued)

(58) **Field of Classification Search**
CPC . A61B 5/04012; A61B 5/0422; A61B 5/6869; A61B 5/6858; A61B 18/1492;
(Continued)

(56) **References Cited**

U.S. PATENT DOCUMENTS

4,114,202 A 9/1978 Roy et al.
4,164,046 A 8/1979 Cooley
(Continued)

FOREIGN PATENT DOCUMENTS

CN 101797181 A 8/2010
EP 0723467 A1 7/1996
(Continued)

OTHER PUBLICATIONS

Office Action issued in copending U.S. Appl. No. 14/564,463 dated Feb. 28, 2017.

(Continued)

Primary Examiner — Michael F Peffley
(74) *Attorney, Agent, or Firm* — Rossi, Kimms & McDowell LLP

(57) **ABSTRACT**

A device positionable in a cavity of a bodily organ (e.g., a heart) may discriminate between fluid (e.g., blood) and non-fluid tissue (e.g., wall of heart) to provide information or a mapping indicative of a position and/or orientation of the device in the cavity. Discrimination may be based on flow, or some other characteristic, for example electrical permittivity or force. The device may selectively ablate portions of the non-fluid tissue based on the information or mapping. The device may detect characteristics (e.g., electrical potentials) indicative of whether ablation was successful. The device may include a plurality of transducers, intravascularly guided in an unexpanded configuration and positioned proximate the non-fluid tissue in an expanded configuration. Expansion mechanism may include helical member(s) or inflatable member(s).

28 Claims, 16 Drawing Sheets

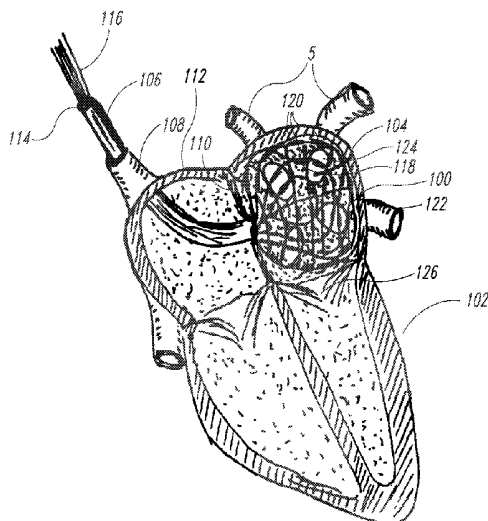

Related U.S. Application Data					
	division of application No. 11/941,819, filed on Nov. 16, 2007, now Pat. No. 8,906,011.				
(51)	Int. Cl.				
	<i>A61B 5/00</i> (2006.01)		5,324,284 A	6/1994	Imran
	<i>A61B 18/18</i> (2006.01)		5,327,889 A	7/1994	Imran
	<i>A61B 18/20</i> (2006.01)		5,341,807 A	8/1994	Nardella
	<i>A61B 18/00</i> (2006.01)		5,345,936 A	9/1994	Pomeranz et al.
	<i>A61B 18/02</i> (2006.01)		5,351,679 A	10/1994	Mayzels et al.
			5,366,443 A	11/1994	Eggers et al.
			5,370,679 A	12/1994	Atlee, III
			5,379,773 A	1/1995	Hornsby
			5,397,321 A	3/1995	Houser et al.
			5,419,767 A	5/1995	Eggers et al.
			5,450,860 A	9/1995	O'Connor
			5,456,254 A	10/1995	Pietroski et al.
			5,465,717 A	11/1995	Imran et al.
			5,478,353 A	12/1995	Yoon
(52)	U.S. Cl.		5,485,849 A	1/1996	Panescu et al.
	CPC <i>A61B 18/18</i> (2013.01); <i>A61B 18/20</i> (2013.01); <i>A61B 2018/00214</i> (2013.01); <i>A61B 2018/00351</i> (2013.01); <i>A61B 2018/00577</i> (2013.01); <i>A61B 2018/00702</i> (2013.01); <i>A61B 2018/00791</i> (2013.01); <i>A61B 2018/025</i> (2013.01)		5,496,267 A	3/1996	Drasler et al.
			5,499,981 A	3/1996	Kordis
			5,531,760 A	7/1996	Alwafaie
			5,545,193 A	8/1996	Fleischman et al.
			5,549,661 A	8/1996	Kordis et al.
			5,555,883 A	9/1996	Avitall
			5,557,967 A	9/1996	Renger
(58)	Field of Classification Search		5,575,810 A	11/1996	Swanson et al.
	CPC <i>A61B 2018/00577</i> ; <i>A61B 2018/00351</i> ; <i>A61B 2018/00839</i> ; <i>A61B 2018/00267</i> ; <i>A61B 2018/1467</i> ; <i>A61B 2018/00357</i> ; <i>A61B 2018/00869</i>		5,593,424 A	1/1997	Northrup, III
	See application file for complete search history.		5,598,848 A	2/1997	Swanson et al.
			5,599,345 A	2/1997	Edwards et al.
			5,620,481 A	4/1997	Desai et al.
			5,637,090 A	6/1997	McGee et al.
			5,662,587 A	9/1997	Grundfest et al.
			5,681,308 A	10/1997	Edwards et al.
			5,681,336 A	10/1997	Clement et al.
(56)	References Cited		5,687,723 A	11/1997	Avitall
	U.S. PATENT DOCUMENTS		5,687,737 A	11/1997	Branham et al.
			5,697,285 A	12/1997	Nappi et al.
			5,713,896 A	2/1998	Nardella
			5,713,942 A	2/1998	Stern et al.
			5,716,397 A	2/1998	Myers
			5,720,726 A	2/1998	Marcadis et al.
			5,728,114 A	3/1998	Evans et al.
			5,730,127 A	3/1998	Avitall
			5,738,096 A	4/1998	Ben-Haim
			5,762,066 A	6/1998	Law et al.
			5,769,846 A	6/1998	Edwards et al.
			5,782,239 A	7/1998	Webster, Jr.
			5,782,879 A	7/1998	Rosborough et al.
			5,800,495 A	9/1998	Machek et al.
			5,823,189 A	10/1998	Kordis
			5,824,066 A	10/1998	Gross
			5,836,947 A	11/1998	Fleischman et al.
			5,836,990 A	11/1998	Li
			5,853,422 A	12/1998	Huebsch et al.
			5,868,755 A	2/1999	Kanner et al.
			5,876,343 A	3/1999	Teo
			5,879,295 A	3/1999	Li et al.
			5,881,727 A	3/1999	Edwards
			5,885,278 A	3/1999	Fleischman
			5,891,136 A	4/1999	McGee et al.
			5,893,847 A	4/1999	Kordis
			5,904,711 A	5/1999	Flom et al.
			5,916,163 A	6/1999	Panescu et al.
			5,919,207 A	7/1999	Taheri
			5,921,924 A	7/1999	Avitall
			5,935,075 A	8/1999	Casscells et al.
			5,935,079 A	8/1999	Swanson et al.
			5,941,251 A	8/1999	Panescu et al.
			5,944,715 A	8/1999	Goble et al.
			5,961,440 A	10/1999	Schweich, Jr. et al.
			5,968,040 A	10/1999	Swanson et al.
			5,984,950 A	11/1999	Cragg et al.
			6,001,069 A	12/1999	Tachibana et al.
			6,001,093 A	12/1999	Swanson et al.
			6,014,581 A	1/2000	Whayne et al.
			6,023,638 A	2/2000	Swanson
			6,030,382 A	2/2000	Fleischman et al.
			6,036,689 A	3/2000	Tu et al.
			6,063,082 A	5/2000	DeVore et al.
			6,071,282 A	6/2000	Fleischman
			6,104,944 A	8/2000	Martinelli
			6,106,522 A	8/2000	Fleischman et al.

(56)

References Cited

U.S. PATENT DOCUMENTS

6,119,030	A	9/2000	Morency	6,824,562	B2	11/2004	Mathis et al.
6,123,702	A	9/2000	Swanson et al.	6,837,886	B2	1/2005	Collins et al.
6,138,043	A	10/2000	Avitall	6,852,076	B2	2/2005	Nikolic et al.
6,142,993	A	11/2000	Wayne et al.	6,855,143	B2	2/2005	Davison et al.
6,156,046	A	12/2000	Passafaro et al.	6,890,353	B2	5/2005	Cohn et al.
6,210,432	B1	4/2001	Solem et al.	6,892,091	B1	5/2005	Ben-Haim et al.
6,216,043	B1	4/2001	Swanson et al.	6,899,674	B2	5/2005	Viebach et al.
6,217,573	B1	4/2001	Webster	6,899,709	B2	5/2005	Lehmann et al.
6,241,747	B1	6/2001	Ruff	6,907,297	B2	6/2005	Wellman et al.
6,245,064	B1	6/2001	Lesh et al.	6,908,478	B2	6/2005	Alferness et al.
6,248,124	B1	6/2001	Pedros et al.	6,913,576	B2	7/2005	Bowman
6,258,258	B1	7/2001	Sartori et al.	6,918,903	B2	7/2005	Bass
6,266,550	B1	7/2001	Selmon et al.	6,926,669	B1	8/2005	Stewart et al.
6,292,695	B1	9/2001	Webster, Jr. et al.	6,936,047	B2	8/2005	Nasab et al.
6,304,769	B1	10/2001	Arenson et al.	6,942,657	B2	9/2005	Sinofsky et al.
6,306,135	B1	10/2001	Ellman et al.	6,949,122	B2	9/2005	Adams et al.
6,308,091	B1	10/2001	Avitall	6,955,640	B2	10/2005	Sanders et al.
6,319,249	B1	11/2001	Tollner	6,960,206	B2	11/2005	Keane
6,322,559	B1	11/2001	Daulton et al.	6,960,229	B2	11/2005	Mathis et al.
6,325,797	B1	12/2001	Stewart et al.	6,966,908	B2	11/2005	Maguire et al.
6,330,478	B1	12/2001	Lee et al.	6,986,775	B2	1/2006	Morales et al.
6,346,105	B1	2/2002	Tu et al.	6,989,010	B2	1/2006	Francischelli et al.
6,350,263	B1	2/2002	Wetzig et al.	6,989,028	B2	1/2006	Lashinski et al.
6,358,258	B1	3/2002	Arcia et al.	6,994,093	B2	2/2006	Murphy et al.
6,383,151	B1	5/2002	Diederich et al.	6,997,925	B2	2/2006	Maguire et al.
6,389,311	B1*	5/2002	Wayne A61B 5/0422 600/523	6,997,951	B2	2/2006	Solem et al.
6,391,024	B1	5/2002	Sun et al.	7,001,383	B2	2/2006	Keidar
6,391,048	B1	5/2002	Ginn et al.	7,003,342	B2	2/2006	Plaza
6,391,054	B2	5/2002	Carpentier et al.	7,025,776	B1	4/2006	Houser et al.
6,402,781	B1	6/2002	Langberg et al.	7,044,135	B2	5/2006	Lesh
6,436,052	B1	8/2002	Nikolic et al.	7,048,734	B1	5/2006	Fleischman et al.
6,471,700	B1	10/2002	Burbank et al.	7,050,848	B2	5/2006	Hoey et al.
6,475,223	B1	11/2002	Werp et al.	7,052,487	B2	5/2006	Cohn et al.
6,485,409	B1	11/2002	Voloshin et al.	7,068,867	B2	6/2006	Adoram et al.
6,485,482	B1	11/2002	Belef	7,141,019	B2	11/2006	Pearlman
6,485,489	B2	11/2002	Teirstein et al.	7,144,363	B2	12/2006	Pai et al.
6,506,210	B1	1/2003	Kanner	7,166,127	B2	1/2007	Spence et al.
6,514,249	B1	2/2003	Maguire et al.	7,174,201	B2	2/2007	Govari et al.
6,529,756	B1	3/2003	Phan et al.	7,177,677	B2	2/2007	Kaula et al.
6,537,198	B1	3/2003	Vidlund et al.	7,186,210	B2	3/2007	Feld et al.
6,537,314	B2	3/2003	Langberg et al.	7,187,964	B2	3/2007	Khoury
6,540,670	B1	4/2003	Hirata et al.	7,189,202	B2	3/2007	Lau et al.
6,551,310	B1	4/2003	Ganz et al.	7,194,294	B2	3/2007	Panescu et al.
6,551,312	B2	4/2003	Zhang et al.	7,198,635	B2	4/2007	Danek et al.
6,558,378	B2	5/2003	Sherman et al.	7,252,664	B2	8/2007	Nasab et al.
6,569,160	B1	5/2003	Goldin et al.	7,255,695	B2	8/2007	Falwell et al.
6,569,198	B1	5/2003	Wilson et al.	7,276,044	B2	10/2007	Ferry et al.
6,575,971	B2	6/2003	Hauck et al.	7,279,007	B2	10/2007	Nikolic et al.
6,589,208	B2	7/2003	Ewers et al.	7,282,030	B2	10/2007	Frei et al.
6,616,684	B1	9/2003	Vidlund et al.	7,300,435	B2	11/2007	Wham et al.
6,626,930	B1	9/2003	Allen et al.	7,303,526	B2	12/2007	Sharkey et al.
6,632,238	B2	10/2003	Ginn et al.	7,311,705	B2	12/2007	Sra
6,635,056	B2	10/2003	Kadhiresan et al.	7,317,950	B2	1/2008	Lee
6,640,119	B1	10/2003	Budd et al.	7,335,196	B2	2/2008	Swanson et al.
6,652,515	B1	11/2003	Maguire et al.	7,340,307	B2	3/2008	Maguire et al.
6,652,517	B1	11/2003	Hall et al.	7,468,062	B2	12/2008	Oral et al.
6,662,034	B2	12/2003	Segner et al.	7,481,808	B2	1/2009	Koyfman et al.
6,666,862	B2	12/2003	Jain et al.	7,496,394	B2	2/2009	Ahmed et al.
D484,979	S	1/2004	Fontaine	7,507,252	B2	3/2009	Lashinski et al.
6,704,590	B2	3/2004	Haldeman	7,530,980	B2	5/2009	Hooven
6,723,038	B1	4/2004	Schroeder et al.	7,575,566	B2	8/2009	Scheib
6,725,085	B2	4/2004	Schwartzman et al.	7,593,760	B2	9/2009	Rodriguez et al.
6,726,716	B2	4/2004	Marquez	7,610,078	B2	10/2009	Willis
6,733,499	B2	5/2004	Scheib	7,633,502	B2	12/2009	Willis et al.
6,735,465	B2	5/2004	Panescu	7,660,452	B2	2/2010	Zwirn et al.
6,738,655	B1	5/2004	Sen et al.	7,736,388	B2	6/2010	Goldfarb et al.
6,760,616	B2	7/2004	Hoey et al.	7,738,967	B2	6/2010	Salo
6,763,836	B2	7/2004	Tasto et al.	7,826,881	B1	11/2010	Beatty et al.
6,773,433	B2	8/2004	Stewart et al.	8,097,926	B2	1/2012	De Graff et al.
6,780,197	B2	8/2004	Roe et al.	8,103,338	B2	1/2012	Harlev et al.
6,788,969	B2	9/2004	Dupree et al.	D654,588	S	2/2012	Taube et al.
6,795,721	B2	9/2004	Coleman et al.	8,118,853	B2	2/2012	Grewe
6,797,001	B2	9/2004	Mathis et al.	8,147,486	B2	4/2012	Honour et al.
6,800,090	B2	10/2004	Alferness et al.	8,150,499	B2	4/2012	Gelbart et al.
				D660,967	S	5/2012	Braido et al.
				8,200,308	B2	6/2012	Zhang et al.
				8,216,216	B2	7/2012	Warnking et al.
				8,216,228	B2	7/2012	Pachon Mateos et al.
				8,221,411	B2	7/2012	Francischelli et al.

(56)

References Cited

U.S. PATENT DOCUMENTS

8,224,432 B2	7/2012	Macadam et al.	9,610,045 B2	4/2017	Du et al.
8,326,419 B2	12/2012	Rosenberg et al.	9,622,806 B2	4/2017	Mihalik
8,352,019 B2	1/2013	Starks	9,629,567 B2	4/2017	Porath et al.
8,386,057 B2	2/2013	Flach et al.	9,636,032 B2	5/2017	Thakur et al.
8,398,623 B2	3/2013	Warnking et al.	9,655,535 B2	5/2017	Narayan et al.
8,401,645 B2	3/2013	Rosenberg et al.	9,662,033 B2	5/2017	Severino
8,414,508 B2	4/2013	Thapliyal et al.	9,693,699 B2	7/2017	Spector et al.
8,442,613 B2	5/2013	Kim et al.	9,713,730 B2	7/2017	Mathur et al.
8,442,625 B2	5/2013	Markowitz et al.	9,730,600 B2	8/2017	Thakur et al.
8,457,371 B2	6/2013	Markowitz et al.	9,730,603 B2	8/2017	Laughner et al.
8,463,368 B2	6/2013	Harlev et al.	9,737,227 B2	8/2017	Thakur et al.
8,486,063 B2	7/2013	Werneth et al.	9,737,267 B2	8/2017	Strom et al.
8,500,731 B2	8/2013	Byrd et al.	9,743,854 B2	8/2017	Stewart et al.
8,532,734 B2	9/2013	Markowitz et al.	9,763,587 B2	9/2017	Altmann
8,538,501 B2	9/2013	Venkatachalam et al.	9,763,625 B2	9/2017	Laughner et al.
8,571,647 B2	10/2013	Harlev et al.	9,782,094 B2	10/2017	Du et al.
8,615,287 B2	12/2013	Harlev et al.	9,795,314 B2	10/2017	Laughner et al.
8,617,156 B2	12/2013	Werneth et al.	9,814,523 B2	11/2017	Condie et al.
8,617,228 B2	12/2013	Wittenberger et al.	9,848,833 B2	12/2017	Govari et al.
8,657,814 B2	2/2014	Werneth et al.	9,855,421 B2	1/2018	Garai et al.
8,663,120 B2	3/2014	Markowitz et al.	9,861,802 B2	1/2018	Mickelsen
8,706,260 B2	4/2014	Stewart et al.	9,875,578 B2	1/2018	Zar et al.
8,712,550 B2	4/2014	Grunewald	9,883,908 B2	2/2018	Madjarov et al.
8,725,240 B2	5/2014	Harlev et al.	9,895,079 B2	2/2018	Massarwa et al.
8,771,267 B2	7/2014	Kunis et al.	9,907,603 B2	3/2018	Sklar et al.
8,831,701 B2	9/2014	Markowitz et al.	9,907,609 B2	3/2018	Cao et al.
8,834,461 B2	9/2014	Werneth et al.	9,913,589 B2	3/2018	Scharf et al.
8,849,384 B2	9/2014	Greenspan	9,918,649 B2	3/2018	Thakur et al.
D717,954 S	11/2014	Hjelle et al.	9,918,788 B2	3/2018	Paul et al.
8,897,516 B2	11/2014	Turgeman	9,924,994 B2	3/2018	Sklar et al.
8,920,411 B2	12/2014	Gelbart et al.	9,924,995 B2	3/2018	Sklar et al.
8,926,605 B2	1/2015	McCarthy et al.	9,940,747 B2	4/2018	Katz et al.
8,932,284 B2	1/2015	McCarthy et al.	9,949,657 B2	4/2018	Ravuna et al.
8,939,970 B2	1/2015	Stone et al.	9,955,889 B2	5/2018	Urman et al.
8,961,506 B2	2/2015	McCarthy et al.	9,968,783 B2	5/2018	Bullinga et al.
9,033,893 B2	5/2015	Spector	9,980,653 B2	5/2018	Lichtenstein et al.
9,037,259 B2	5/2015	Mathur	9,987,083 B2	6/2018	Gelbart et al.
9,044,245 B2	6/2015	Condie et al.	9,987,084 B2	6/2018	Gelbart et al.
9,044,254 B2	6/2015	Ladtchow et al.	10,004,413 B2	6/2018	Bokan et al.
9,095,350 B2	8/2015	Condie et al.	10,010,368 B2	7/2018	Laske et al.
9,101,333 B2	8/2015	Schwartz	10,016,145 B2	7/2018	Thakur et al.
9,101,365 B2	8/2015	Highsmith	10,028,783 B2	7/2018	Gelbart et al.
9,107,599 B2	8/2015	Harlev et al.	10,064,678 B2	9/2018	Corvi et al.
9,108,052 B2	8/2015	Jarrard	10,085,659 B2	10/2018	Laughner et al.
9,119,633 B2	9/2015	Gelbart et al.	2001/0003158 A1	6/2001	Kensey et al.
9,119,634 B2	9/2015	Gelbart et al.	2001/0005787 A1	6/2001	Oz et al.
9,179,860 B2	11/2015	Markowitz et al.	2001/0018611 A1	8/2001	Solem et al.
9,179,972 B2	11/2015	Olson	2001/0020126 A1	9/2001	Swanson et al.
9,198,713 B2	12/2015	Wallace et al.	2001/0021867 A1	9/2001	Kordis et al.
9,204,935 B2	12/2015	Hauck et al.	2002/0002329 A1	1/2002	Avitall
9,265,434 B2	2/2016	Merschon et al.	2002/0016628 A1	2/2002	Langberg et al.
9,277,872 B2	3/2016	Harlev et al.	2002/0087156 A1	7/2002	Maguire et al.
9,277,960 B2	3/2016	Weinkam et al.	2002/0087157 A1	7/2002	Sliwa, Jr. et al.
9,282,910 B2	3/2016	Narayan et al.	2002/0087173 A1	7/2002	Alferness et al.
9,332,920 B2	5/2016	Thakur et al.	2002/0099415 A1	7/2002	Panescu et al.
9,345,540 B2	5/2016	Mallin et al.	2002/0107478 A1	8/2002	Wendlandt
9,398,862 B2	7/2016	Harlev et al.	2002/0107511 A1	8/2002	Collins et al.
9,408,544 B2	8/2016	Laughner et al.	2002/0107530 A1	8/2002	Saucer et al.
9,433,465 B2	9/2016	Gliner et al.	2002/0115941 A1	8/2002	Whayne et al.
9,439,578 B2	9/2016	Thakur et al.	2002/0115944 A1	8/2002	Mendes et al.
9,456,759 B2	10/2016	Lian et al.	2002/0165535 A1	11/2002	Lesh et al.
9,474,486 B2	10/2016	Eliason et al.	2002/0169445 A1	11/2002	Jain et al.
9,474,491 B2	10/2016	Li et al.	2002/0169504 A1	11/2002	Alferness et al.
9,486,272 B2	11/2016	Bonyak et al.	2002/0177782 A1	11/2002	Penner
9,504,518 B2	11/2016	Condie et al.	2002/0183836 A1	12/2002	Liddicoat et al.
9,522,035 B2	12/2016	Highsmith	2002/0183841 A1	12/2002	Cohn et al.
9,526,568 B2	12/2016	Ohri et al.	2002/0188170 A1	12/2002	Santamore et al.
9,532,725 B2	1/2017	Laughner et al.	2003/0028118 A1	2/2003	Dupree et al.
9,532,828 B2	1/2017	Condie et al.	2003/0028183 A1	2/2003	Sanchez et al.
9,554,718 B2	1/2017	Bar-Tal et al.	2003/0050637 A1	3/2003	Maguire et al.
9,554,847 B2	1/2017	Govari et al.	2003/0050685 A1	3/2003	Nikolic et al.
9,572,620 B2	2/2017	Ryu et al.	2003/0055420 A1	3/2003	Kadhiresan et al.
9,579,064 B2	2/2017	Kovtun et al.	2003/0060820 A1	3/2003	Maguire et al.
9,603,651 B2	3/2017	Ghosh	2003/0069570 A1	4/2003	Witzel et al.
9,603,661 B2	3/2017	Gelbart et al.	2003/0069636 A1	4/2003	Solem et al.
			2003/0078465 A1	4/2003	Pai et al.
			2003/0078494 A1	4/2003	Panescu et al.
			2003/0078509 A1	4/2003	Panescu
			2003/0078671 A1	4/2003	Lesniak et al.

(56)

References Cited

U.S. PATENT DOCUMENTS

2003/0105384	A1	6/2003	Sharkey et al.	2006/0173251	A1	8/2006	Govari et al.
2003/0105520	A1	6/2003	Alferness et al.	2006/0184242	A1	8/2006	Lichtenstein
2003/0109770	A1	6/2003	Sharkey et al.	2006/0199995	A1	9/2006	Vijay
2003/0125726	A1	7/2003	Maguire et al.	2006/0229491	A1	10/2006	Sharkey et al.
2003/0176810	A1	9/2003	Maahs et al.	2006/0235286	A1	10/2006	Stone et al.
2003/0181819	A1	9/2003	Desai	2006/0235314	A1	10/2006	Migliuolo et al.
2003/0229395	A1	12/2003	Cox	2006/0264980	A1	11/2006	Khairkhahan et al.
2004/0002626	A1	1/2004	Feld et al.	2006/0281965	A1	12/2006	Khairkhahan et al.
2004/0006337	A1	1/2004	Nasab et al.	2006/0293698	A1	12/2006	Douk
2004/0054279	A1	3/2004	Hanley	2006/0293725	A1	12/2006	Rubinsky et al.
2004/0133220	A1	7/2004	Lashinski et al.	2007/0016068	A1	1/2007	Grunwald et al.
2004/0133273	A1	7/2004	Cox	2007/0027533	A1	2/2007	Douk
2004/0138744	A1	7/2004	Lashinski et al.	2007/0038208	A1	2/2007	Kefer
2004/0153146	A1	8/2004	Lashinski et al.	2007/0083193	A1	4/2007	Werneth et al.
2004/0158321	A1	8/2004	Reuter et al.	2007/0083195	A1	4/2007	Werneth et al.
2004/0176797	A1	9/2004	Opolski	2007/0088362	A1	4/2007	Bonutti et al.
2004/0181139	A1	9/2004	Falwell et al.	2007/0115390	A1	5/2007	Makara et al.
2004/0186566	A1	9/2004	Hindrichs et al.	2007/0118215	A1	5/2007	Moaddeb
2004/0215232	A1	10/2004	Belhe et al.	2007/0129717	A1	6/2007	Brown, III et al.
2004/0243170	A1	12/2004	Suresh et al.	2007/0161846	A1	7/2007	Nikolic et al.
2004/0249408	A1	12/2004	Murphy et al.	2007/0198058	A1	8/2007	Gelbart et al.
2004/0249453	A1	12/2004	Cartledge et al.	2007/0213578	A1	9/2007	Khairkhahan et al.
2004/0267358	A1	12/2004	Reitan	2007/0213815	A1	9/2007	Khairkhahan et al.
2005/0004668	A1	1/2005	Aklog et al.	2007/0232858	A1	10/2007	Macnamara et al.
2005/0010206	A1	1/2005	Nasab et al.	2007/0249999	A1	10/2007	Sklar et al.
2005/0015109	A1	1/2005	Lichtenstein	2007/0270688	A1	11/2007	Gelbart et al.
2005/0054938	A1	3/2005	Wehman et al.	2007/0299343	A1	12/2007	Waters
2005/0055089	A1	3/2005	Macoviak et al.	2008/0004534	A1	1/2008	Gelbart et al.
2005/0060030	A1	3/2005	Lashinski et al.	2008/0004643	A1	1/2008	To et al.
2005/0064665	A1	3/2005	Han	2008/0004697	A1	1/2008	Lichtenstein et al.
2005/0065420	A1	3/2005	Collins et al.	2008/0045778	A1	2/2008	Lichtenstein et al.
2005/0065504	A1	3/2005	Melsky et al.	2008/0071298	A1	3/2008	Khairkhahan et al.
2005/0080402	A1	4/2005	Santamore et al.	2008/0161799	A1	7/2008	Stangenes et al.
2005/0096047	A1	5/2005	Haberman et al.	2008/0172048	A1	7/2008	Martin et al.
2005/0096647	A1	5/2005	Steinke et al.	2008/0262337	A1	10/2008	Falwell et al.
2005/0107723	A1	5/2005	Wehman et al.	2008/0281322	A1	11/2008	Sherman et al.
2005/0107871	A1	5/2005	Realyvasquez et al.	2008/0312713	A1*	12/2008	Wilfley A61B 5/053
2005/0125030	A1	6/2005	Forsberg et al.	2009/0018617	A1	1/2009	Skelton et al.
2005/0148892	A1	7/2005	Desai	2009/0024138	A1	1/2009	Saleh
2005/0149014	A1	7/2005	Hauck et al.	2009/0069704	A1	3/2009	MacAdam et al.
2005/0149159	A1	7/2005	Andreas et al.	2009/0131930	A1	5/2009	Gelbart et al.
2005/0154252	A1	7/2005	Sharkey et al.	2009/0157058	A1	6/2009	Ferren et al.
2005/0165388	A1	7/2005	Bhola	2009/0171274	A1	7/2009	Harlev et al.
2005/0182365	A1	8/2005	Hennemann et al.	2009/0182325	A1	7/2009	Werneth et al.
2005/0187620	A1	8/2005	Pai et al.	2009/0192441	A1	7/2009	Gelbart et al.
2005/0197593	A1	9/2005	Burbank et al.	2009/0253976	A1	10/2009	Harlev et al.
2005/0197692	A1	9/2005	Pai et al.	2009/0270737	A1	10/2009	Thornton
2005/0197693	A1	9/2005	Pai et al.	2009/0287271	A1	11/2009	Blum et al.
2005/0197694	A1	9/2005	Pai et al.	2009/0287304	A1	11/2009	Dahlgren et al.
2005/0203558	A1	9/2005	Maschke	2010/0016762	A1	1/2010	Thapliyal et al.
2005/0209636	A1	9/2005	Widomski et al.	2010/0023004	A1	1/2010	Francischelli et al.
2005/0216054	A1	9/2005	Widomski et al.	2010/0113928	A1	5/2010	Thapliyal et al.
2005/0240249	A1	10/2005	Tu et al.	2010/0113985	A1	5/2010	Thapliyal et al.
2005/0251116	A1	11/2005	Steinke et al.	2010/0121147	A1	5/2010	Oskin et al.
2005/0251132	A1	11/2005	Oral et al.	2010/0211052	A1	8/2010	Brown et al.
2005/0256521	A1	11/2005	Kozel	2010/0249771	A1	9/2010	Pearson et al.
2005/0261580	A1	11/2005	Willis et al.	2010/0268059	A1	10/2010	Ryu et al.
2005/0267458	A1	12/2005	Paul et al.	2010/0286551	A1	11/2010	Harlev et al.
2005/0267574	A1	12/2005	Cohn et al.	2011/0034912	A1	2/2011	De Graff et al.
2006/0009755	A1	1/2006	Sra	2011/0125172	A1	5/2011	Gelbart et al.
2006/0009756	A1	1/2006	Francischelli et al.	2011/0172658	A1	7/2011	Gelbart et al.
2006/0014998	A1	1/2006	Sharkey et al.	2011/0213231	A1	9/2011	Hall et al.
2006/0015002	A1	1/2006	Moaddeb et al.	2011/0282491	A1	11/2011	Prisco et al.
2006/0015003	A1	1/2006	Moaddes et al.	2012/0078076	A1	3/2012	Stewart et al.
2006/0015038	A1	1/2006	Weymarn-Scharli	2012/0136346	A1	5/2012	Condie et al.
2006/0015096	A1	1/2006	Hauck et al.	2012/0136348	A1	5/2012	Condie et al.
2006/0025800	A1	2/2006	Suresh	2012/0158016	A1	6/2012	Gelbart et al.
2006/0030881	A1	2/2006	Sharkey et al.	2012/0165829	A1	6/2012	Chen et al.
2006/0084966	A1	4/2006	Maguire et al.	2012/0172859	A1	7/2012	Condie et al.
2006/0085049	A1	4/2006	Cory et al.	2012/0172867	A1	7/2012	Ryu et al.
2006/0089637	A1	4/2006	Werneth et al.	2012/0271135	A1	10/2012	Burke et al.
2006/0100618	A1	5/2006	Chan et al.	2012/0277567	A1	11/2012	Harlev et al.
2006/0106298	A1	5/2006	Ahmed et al.	2013/0066220	A1	3/2013	Weinkam et al.
2006/0135968	A1	6/2006	Schaller	2013/0165916	A1	6/2013	Mathur et al.
2006/0135970	A1	6/2006	Schaller	2013/0172883	A1	7/2013	Lopes et al.
				2013/0178850	A1	7/2013	Lopes et al.
				2013/0178851	A1	7/2013	Lopes et al.
				2013/0184705	A1	7/2013	Gelbart et al.

A61B 5/053

607/41

(56)

References Cited

U.S. PATENT DOCUMENTS

2013/0184706 A1 7/2013 Gelbart et al.
 2013/0190587 A1 7/2013 Lopes et al.
 2013/0190741 A1 7/2013 Moll et al.
 2013/0197513 A1 8/2013 Lopes et al.
 2013/0241929 A1 9/2013 Massarwa et al.
 2013/0274562 A1 10/2013 Ghaffari et al.
 2013/0296679 A1 11/2013 Condie et al.
 2013/0296850 A1 11/2013 Olson
 2013/0304065 A1 11/2013 Lopes et al.
 2013/0310828 A1 11/2013 Reinders et al.
 2013/0345538 A1 12/2013 Harlev et al.
 2014/0114307 A1 4/2014 Moisa et al.
 2014/0121659 A1 5/2014 Paul et al.
 2014/0213894 A1 7/2014 Gelbart et al.
 2014/0296850 A1 10/2014 Condie et al.
 2014/0303610 A1 10/2014 McCarthy et al.
 2014/0303614 A1 10/2014 McCarthy et al.
 2014/0350552 A1 11/2014 Highsmith
 2014/0364848 A1 12/2014 Heimbecher et al.
 2015/0032103 A1 1/2015 McLawhorn et al.
 2015/0066010 A1 3/2015 McLawhorn et al.
 2015/0105701 A1 4/2015 Mayer et al.
 2015/0126993 A1 5/2015 Gelbart et al.
 2015/0157400 A1 6/2015 Gelbart et al.
 2015/0182740 A1 7/2015 Mickelsen
 2015/0245798 A1 9/2015 Gelbart et al.
 2015/0250539 A1 9/2015 Gelbart et al.
 2015/0351836 A1 12/2015 Prutchi
 2015/0351837 A1 12/2015 Gelbart et al.
 2015/0366508 A1 12/2015 Chou et al.
 2016/0008059 A1 1/2016 Prutchi
 2016/0008061 A1 1/2016 Fung et al.
 2016/0008062 A1 1/2016 Gelbart et al.
 2016/0058505 A1 3/2016 Condie et al.
 2016/0100884 A1 4/2016 Fay et al.
 2016/0106498 A1 4/2016 Highsmith
 2016/0143686 A1 5/2016 Tunay et al.
 2016/0175009 A1 6/2016 Davies et al.
 2016/0242667 A1 8/2016 Fay et al.
 2016/0262647 A1 9/2016 Berenfeld
 2016/0287137 A1 10/2016 Condie et al.
 2016/0302858 A1 10/2016 Bencini
 2016/0317223 A1 11/2016 Avitall
 2016/0331259 A1 11/2016 Harlev et al.
 2016/0346030 A1 12/2016 Thapliyal et al.
 2016/0367315 A1 12/2016 Moisa et al.
 2017/0020604 A1 1/2017 Lopes et al.
 2017/0027465 A1 2/2017 Blauer et al.
 2017/0035486 A1 2/2017 Lopes et al.
 2017/0035499 A1 2/2017 Stewart et al.
 2017/0065198 A1 3/2017 Ruppertsberg
 2017/0065339 A1 3/2017 Mickelsen
 2017/0065340 A1 3/2017 Long
 2017/0065812 A1 3/2017 Goedeke et al.
 2017/0071661 A1 3/2017 Hoitink et al.
 2017/0079712 A1 3/2017 Levin et al.
 2017/0092013 A1 3/2017 Perlman et al.
 2017/0100189 A1 4/2017 Clark et al.
 2017/0103570 A1 4/2017 Zar et al.
 2017/0105627 A1 4/2017 Katz et al.
 2017/0119453 A1 5/2017 Ryu et al.
 2017/0143414 A1 5/2017 Sliwa et al.
 2017/0156791 A1 6/2017 Govari
 2017/0156792 A1 6/2017 Ziv-Ari et al.
 2017/0164858 A1 6/2017 Basu
 2017/0202470 A1 7/2017 Urman et al.
 2017/0202516 A1 7/2017 Bar-Tal et al.
 2017/0202521 A1 7/2017 Urman et al.
 2017/0215947 A1 8/2017 Rioux et al.
 2017/0281193 A1 10/2017 Asirvatham et al.
 2017/0296084 A1 10/2017 Blauer et al.
 2017/0312012 A1 11/2017 Harlev et al.
 2017/0312028 A1 11/2017 Harlev et al.
 2018/0008343 A1 1/2018 Gelbart et al.
 2018/0020916 A1 1/2018 Ruppertsberg

2018/0036074 A1 2/2018 Gelbart et al.
 2018/0036075 A1 2/2018 Gelbart et al.
 2018/0036076 A1 2/2018 Gelbart et al.
 2018/0036077 A1 2/2018 Gelbart et al.
 2018/0042667 A1 2/2018 Pappone et al.
 2018/0042671 A1 2/2018 Gelbart et al.
 2018/0042674 A1 2/2018 Mickelsen
 2018/0042675 A1 2/2018 Long
 2018/0055565 A1 3/2018 Gelbart et al.
 2018/0056074 A1 3/2018 Clark et al.
 2018/0064488 A1 3/2018 Long et al.
 2018/0068439 A1 3/2018 Hareland
 2018/0071017 A1 3/2018 Bar-Tal et al.
 2018/0092688 A1 4/2018 Tegg
 2018/0093088 A1 4/2018 Mickelsen
 2018/0110561 A1 4/2018 Levin et al.
 2018/0116595 A1 5/2018 Ruppertsberg
 2018/0117304 A1 5/2018 Koop et al.
 2018/0125575 A1 5/2018 Schwartz et al.
 2018/0153437 A1 6/2018 Schwartz et al.
 2018/0158238 A1 6/2018 Cohen et al.
 2018/0160978 A1 6/2018 Cohen et al.
 2018/0161097 A1 6/2018 Zoabi et al.
 2018/0177467 A1 6/2018 Katz et al.
 2018/0177552 A1 6/2018 Zoabi et al.
 2018/0182157 A1 6/2018 Zar et al.
 2018/0182159 A1 6/2018 Cohen et al.
 2018/0190009 A1 7/2018 Cohen et al.
 2018/0199976 A1 7/2018 Fischer
 2018/0199990 A1 7/2018 Monir et al.
 2018/0200497 A1 7/2018 Mickelsen
 2018/0206920 A1 7/2018 Pappone et al.
 2018/0214202 A1 8/2018 Howard et al.
 2018/0235692 A1 8/2018 Efimov et al.
 2018/0236221 A1 8/2018 Opie et al.
 2018/0242868 A1 8/2018 Cohen et al.
 2018/0256055 A1 9/2018 Zigelman et al.
 2018/0280070 A1 10/2018 Pasquino et al.
 2018/0296114 A1 10/2018 Welsh et al.
 2018/0325597 A1 11/2018 Schwartz et al.

FOREIGN PATENT DOCUMENTS

EP 1169974 A1 1/2002
 EP 1169976 A1 1/2002
 EP 1240868 A1 9/2002
 EP 1182980 B1 6/2006
 EP 1233718 B1 8/2006
 EP 1923095 A2 5/2008
 EP 1280467 B1 11/2008
 EP 1451595 B1 7/2009
 EP 1814450 B1 1/2013
 EP 1909679 B1 11/2013
 EP 2101642 B1 7/2014
 EP 2307098 B1 3/2015
 EP 2848191 A1 3/2015
 EP 2231060 B1 5/2015
 EP 2873365 A1 5/2015
 EP 2984986 A2 2/2016
 EP 2395933 B1 5/2016
 EP 2645953 B1 8/2016
 EP 2661236 B1 8/2016
 EP 2749213 B1 9/2016
 EP 2604211 B1 10/2016
 EP 3130285 A1 2/2017
 EP 3141185 A1 3/2017
 EP 2689722 B1 6/2017
 EP 2566565 B1 10/2017
 EP 2613723 B1 10/2017
 EP 3225161 A1 10/2017
 EP 2892454 B1 1/2018
 EP 3318211 A2 5/2018
 EP 3321890 A1 5/2018
 EP 3102136 B1 6/2018
 EP 2765939 B1 9/2018
 EP 2793725 B1 9/2018
 EP 3139997 B1 9/2018
 EP 3375365 A2 9/2018
 WO 9510320 A1 4/1995

(56)

References Cited

FOREIGN PATENT DOCUMENTS

WO	95/20349	A1	8/1995
WO	97/17892	A1	5/1997
WO	0108575	A2	2/2001
WO	02/087437	A1	11/2002
WO	03015611	A2	2/2003
WO	03077800	A1	9/2003
WO	2004012629	A1	2/2004
WO	2004047679	A1	6/2004
WO	2004084746	A2	10/2004
WO	2004100803	A1	11/2004
WO	2005070330	A1	8/2005
WO	2005102181	A1	11/2005
WO	2006017809	A2	2/2006
WO	2006105121	A2	10/2006
WO	2006135747	A2	12/2006
WO	2006135749	A2	12/2006
WO	2007021647	A2	2/2007
WO	2007115390	A1	10/2007
WO	2008002606	A2	1/2008
WO	2009011721	A1	1/2009
WO	2009065042	A2	5/2009
WO	2012050877	A1	4/2012
WO	2012/100184	A2	7/2012
WO	2012/100185	A2	7/2012
WO	2013/173917	A1	11/2013
WO	2016181316	A1	11/2016
WO	2016181317	A2	11/2016
WO	2016181318	A1	11/2016
WO	2016183468	A1	11/2016
WO	2017009165	A1	1/2017
WO	2017024123	A1	2/2017
WO	2017041889	A2	3/2017
WO	2017041891	A1	3/2017
WO	2017042623	A1	3/2017
WO	2017056056	A1	4/2017
WO	2017070252	A1	4/2017
WO	2017087740	A1	5/2017
WO	2017120169	A1	7/2017
WO	2017136262	A1	8/2017
WO	2017192480	A2	11/2017
WO	2017192495	A1	11/2017
WO	2017192510	A2	11/2017
WO	2017192542	A2	11/2017
WO	2018023132	A1	2/2018
WO	2018067540	A1	4/2018
WO	2018075396	A1	4/2018
WO	2018081225	A1	5/2018
WO	2018144765	A1	8/2018
WO	2018146613	A2	8/2018
WO	2018165425	A1	9/2018

OTHER PUBLICATIONS

Notice of Allowance issued in copending U.S. Appl. No. 13/942,354 dated Feb. 10, 2017.

Gelbart et al., "Apparatus and Method for Intra-Cardiac Mapping and Ablation", Amendment filed in co-pending U.S. Appl. No. 13/785,310 dated Mar. 24, 2017, 150 pgs.

Gelbart et al., "Medical Device for Use in Bodily Lumens, for Example an Atrium", Amendment filed in co-pending U.S. Appl. No. 14/521,692 dated Mar. 31, 2017, 9 pgs.

Office Action issued in Chinese Patent Application No. 201510432392.3 dated Mar. 8, 2017. English concise Explanation of Relevance provided.

Decision to Refuse a European Patent Application issued in European Patent Application No. 13172848.7 dated Feb. 22, 2017.

Notice of Allowance issued in copending U.S. Appl. No. 14/521,692 dated May 19, 2017.

Office Action issued in copending U.S. Appl. No. 14/713,114 dated Jun. 1, 2017.

Quayle Action issued in copending U.S. Appl. No. 14/713,190 dated May 30, 2017.

Office Action issued in German Application No. 112008003108.8 dated May 8, 2017. English translation provided.

Amendment filed in copending U.S. Appl. No. 14/564,463, filed May 25, 2017.

Office Action issued in copending U.S. Appl. No. 14/564,463 dated Jul. 17, 2017.

European Search Report issued in European Appln. No. 14871405.8 dated Jul. 5, 2017.

Preliminary Amendment filed in copending U.S. Appl. No. 15/299,640 pp. 4 filed Oct. 21, 2016.

Preliminary Amendment filed in copending U.S. Appl. No. 15/299,640 pp. 11 filed Dec. 9, 2016.

Response to Quayle Office Action filed in copending U.S. Appl. No. 14/713,190, filed Jul. 24, 2017.

Preliminary Amendment filed in copending U.S. Appl. No. 14/521,692, filed Oct. 23, 2014.

Copending U.S. Appl. No. 16/161,319, filed Oct. 16, 2018 (a copy is not included because the cited application is not yet available to the public and the Examiner has ready access to the cited application).

Notice of Allowance issued in U.S. Appl. No. 13/785,910 dated Jun. 15, 2018.

Examination Report issued in European Appln. No. 14871405.8 dated Jul. 6, 2018.

Preliminary Amendment filed in copending U.S. Appl. No. 15/697,744 dated Sep. 21, 2017.

Amendment filed in copending U.S. Appl. No. 14/564,463 dated Oct. 17, 2017.

Notice of Allowance issued in copending U.S. Appl. No. 14/713,114 dated Nov. 1, 2017.

Notice of Allowance issued in copending U.S. Appl. No. 14/564,463 dated Nov. 9, 2017.

Preliminary Amendment filed in copending U.S. Appl. No. 15/784,555 dated Nov. 7, 2017.

Preliminary Amendment filed in copending U.S. Appl. No. 15/784,775 dated Nov. 7, 2017.

Preliminary Amendment filed in copending U.S. Appl. No. 15/784,722 dated Nov. 7, 2017.

Preliminary Amendment filed in copending U.S. Appl. No. 15/725,731 dated Oct. 24, 2017.

Preliminary Amendment filed in copending U.S. Appl. No. 15/784,647 dated Nov. 7, 2017.

Preliminary Amendment filed in copending U.S. Appl. No. 15/725,662 dated Oct. 24, 2017.

Office Action issued in copending U.S. Appl. No. 14/804,924 dated Nov. 17, 2017.

Response to Office Action filed in copending U.S. Appl. No. 13/785,910 dated Nov. 30, 2017.

Amendment filed in copending U.S. Appl. No. 13/785,910 dated Feb. 27, 2018.

Examination Report issued in European Application No. 13793216.6 dated Nov. 24, 2017.

Office Action issued in Chinese Application No. 201510432392.3 dated Nov. 17, 2017. Concise Explanation of Relevance and English translation provided.

Examination Report issued in European Application No. 15188407.9 dated Dec. 11, 2017.

Office Action issued in copending U.S. Appl. No. 13/785,910 dated Jan. 12, 2018.

Amendment filed in copending U.S. Appl. No. 14/804,924 dated Feb. 27, 2018.

Office Action issued in copending U.S. Appl. No. 14/804,810 dated Nov. 30, 2017.

Amendment filed in copending U.S. Appl. No. 14/804,810 dated Feb. 27, 2018.

Notice of Allowance issued in copending U.S. Appl. No. 14/804,924 dated Mar. 27, 2018.

Notice of Allowance issued in copending U.S. Appl. No. 14/804,810 dated Mar. 30, 2018.

Office Action issued in Chinese Application No. 201510432392.3 dated May 18, 2018. Concise Explanation of Relevance provided.

(56)

References Cited

OTHER PUBLICATIONS

- Buchbinder, Maurice MD, "Dynamic Mitral Valve Annuloplasty: A Reshapable Ring for Residual and Recurring MR," from the Foundation for Cardiovascular Medicine, La Jolla, CA. May 24, 2007.
- Gabriel et al., "The Dielectric Properties of Biological Tissues: I. Literature Survey," *Phys. Med. Biol.* 41:2231-2249, 1996.
- Konings et al., "Development of an Intravascular Impedance Catheter for Detection of Fatty Lesions in Arteries," *IEEE Transactions on Medical Imaging*, 16(4):439-446, 1997.
- Mack, "New Techniques for Percutaneous Repair of the Mitral Valve," *Heart Failure Review*, 11:259-268, 2006.
- Otasevic et al., "First-in-Man Implantation of Left Ventricular Partitioning Device in a Patient With Chronic Heart Failure: Twelve-Month Follow-up," *Journal of Cardiac Failure* 13(7):517-520, 2007.
- Sharkey et al., "Left Ventricular Apex Occluder. Description of a Ventricular Partitioning Device," *EuroIntervention* 2:125-127, 2006.
- Stiles, et al., "Simulated Characterization of Atherosclerotic Lesions in the Coronary Arteries by Measurement of Bioimpedance," *IEE Transactions on Biomedical Engineering*, 50(7):916-921, 2003.
- Tanaka et al., "Artificial SMA Valve for Treatment of Urinary Incontinence: Upgrading of Valve and Introduction of Transcatheter Transformer," *Bio-Medical Materials and Engineering* 9:97-112, 1999.
- Timek et al., "Septal-Lateral Annular Cinching ('Slac') Reduces Mitral Annular Size Without Perturbing Normal Annular Dynamics," *Journal of Heart Valve Disease* 11 (1):2-10, 2002.
- Timek et al., "Septal-Lateral Annular Cinching Abolishes Acute Ischemic Mitral Regurgitation," *Journal of Thoracic and Cardiovascular Surgery*, 123(5):881-888, 2002.
- Valvano et al., "Thermal Conductivity and Diffusivity of Biomaterials Measured with Self-Heated Thermistors," *International Journal of Thermodynamics*, 6(3):301-311, 1985.
- Gelbart et al., "Automatic Atherectomy System," Office Action dated Mar. 4, 2009 for U.S. Appl. No. 11/436,584, 7 pages.
- Gelbart et al., "Automatic Atherectomy System," Amendment filed Aug. 4, 2009 for U.S. Appl. No. 11/436,584, 35 pages.
- Gelbart et al., "Automatic Atherectomy System," Office Action dated Dec. 1, 2009 for U.S. Appl. No. 11/436,584, 10 pages.
- Gelbart et al., "Automatic Atherectomy System," Amendment filed Mar. 30, 2010 for U.S. Appl. No. 11/436,584, 20 pages.
- Gelbart et al., "Automatic Atherectomy System," Amendment filed Oct. 25, 2010 for U.S. Appl. No. 11/436,584, 9 pages.
- Gelbart et al., "Automatic Atherectomy System," Office Action dated Dec. 14, 2010 for U.S. Appl. No. 11/436,584, 12 pages.
- Gelbart et al., "Intra-Cardiac Mapping and Ablation Method," Preliminary Amendment filed Aug. 29, 2007 for U.S. Appl. No. 11/475,950, 42 pages.
- Gelbart et al., "Intra-Cardiac Mapping and Ablation Method," Amendment filed Mar. 5, 2008 for U.S. Appl. No. 11/475,950, 11 pages.
- Gelbart et al., "Intra-Cardiac Mapping and Ablation Method," Office Action dated Jun. 23, 2010 for U.S. Appl. No. 11/475,950, 18 pages.
- Gelbart et al., "Intra-Cardiac Mapping and Ablation Method," Amendment filed Aug. 16, 2010 for U.S. Appl. No. 11/475,950, 22 pages.
- Gelbart et al., "Intra-Cardiac Mapping and Ablation Method," Office Action dated Nov. 23, 2010 for U.S. Appl. No. 11/475,950, 25 pages.
- Gelbart et al., "Intra-Cardiac Mapping and Ablation Method," Amendment filed Feb. 23, 2011 for U.S. Appl. No. 11/475,950, 28 pages.
- Gelbart et al., "Automatic Atherectomy System," Office Action dated Jun. 15, 2011, for U.S. Appl. No. 12/950,871, 16 pages.
- Gelbart et al., "Liposuction System," Office Action dated Mar. 16, 2011 for U.S. Appl. No. 12/010,458, 12 pages.
- Gelbart et al., "Liposuction System," Amendment filed Jun. 10, 2011 for U.S. Appl. No. 12/010,458, 10 pages.
- Lichtenstein "Method and Apparatus for Percutaneous Reduction of Anterior-Posterior Diameter of Mitral Valve," U.S. Appl. No. 10/690,131, filed Oct. 20, 2003, 31 pages.
- International Search Report, dated Dec. 5, 2007, for PCT/US2007/014902, 5 pages.
- International Preliminary Report on Patentability, dated Jan. 6, 2009, for PCT/US2007/014902, 8 pages.
- International Search Report, dated Dec. 2, 2009, for PCT/US2008/083644, 5 pages.
- Written Opinion, dated Dec. 5, 2007, for PCT/US2007/014902, 7 pages.
- Written Opinion, dated Dec. 2, 2009, for PCT/US2008/083644, 9 pages.
- Gelbart et al., "Automatic Atherectomy System," Amendment filed Sep. 15, 2011 for U.S. Appl. No. 12/950,871, 21 pages.
- Gelbart et al., "Liposuction System," Amendment filed Dec. 7, 2011 for U.S. Appl. No. 12/010,458, 15 pages.
- Gelbart et al., "Liposuction System," Office Action dated Sep. 14, 2011 for U.S. Appl. No. 12/010,458, 9 pages.
- Notice of Allowance issued in U.S. Appl. No. 13/782,889, dated Aug. 25, 2016.
- Lopes et al., "Intra-Cardiac Procedure Device", Amendment filed in co-pending U.S. Appl. No. 29/509,636, filed Jul. 22, 2016, 5 pgs.
- Lopes et al., "Intra-Cardiac Procedure Device", Amendment filed in co-pending U.S. Appl. No. 29/509,636 dated Nov. 17, 2016, 3 pgs.
- Lopes et al., "High-Density Electrode-Based Medical Device System", Preliminary Amendment filed in co-pending U.S. Appl. No. 15/287,988 dated Nov. 23, 2016, 9 pgs.
- Lopes et al., "Intra-Cardiac Procedure Device", Amendment filed in co-pending U.S. Appl. No. 29/509,621 dated Jul. 22, 2016, 5 pgs.
- Lopes et al., "Intra-Cardiac Procedure Device", Amendment filed in co-pending U.S. Appl. No. 29/509,621 dated Nov. 17, 2016, 3 pgs.
- Lopes et al., "Enhanced Medical Device for Use in Bodily Cavities, for Example an Atrium", Amendment filed in co-pending U.S. Appl. No. 13/782,889 dated May 17, 2016, 51 pgs.
- Lopes et al., "High-Density Electrode-Based Medical Device System" Amendment filed in co-pending U.S. Appl. No. 13/793,213 dated May 26, 2016, 39 pgs.
- Lopes et al., "Enhanced Medical Device for Use in Bodily Cavities, for Example an Atrium", Amendment filed in co-pending U.S. Appl. No. 13/782,867 dated May 17, 2016, 39 pgs.
- Gelbart et al., "Intra-Cardiac Mapping and Ablation Method", Amendment filed in co-pending U.S. Appl. No. 11/475,950 dated Feb. 12, 2013, 4 pgs.
- Moisa et al., "Catheter System", Preliminary Amendment filed in co-pending U.S. Appl. No. 15/254,130 dated Sep. 19, 2016, 22 pgs.
- Gelbart et al., "Apparatus and Method for Intra-Cardiac Mapping and Ablation", Preliminary Amendment filed in co-pending U.S. Appl. No. 14/804,924 dated Jul. 30, 2015, 5 pgs.
- Gelbart et al., "Apparatus and Method for Intra-Cardiac Mapping and Ablation", Preliminary Amendment filed in co-pending U.S. Appl. No. 14/804,810 dated Jul. 30, 2015, 10 pgs.
- Gelbart et al., "Medical Device for Use in Bodily Lumens, for Example an Atrium", Preliminary Amendment filed in co-pending U.S. Appl. No. 14/713,190 dated May 15, 2015, 3 pgs.
- Gelbart et al., "Medical Device for Use in Bodily Lumens, for Example an Atrium", Preliminary Amendment filed in co-pending U.S. Appl. No. 14/713,190 dated Jun. 16, 2015, 7 pgs.
- Gelbart et al., "Medical Device for Use in Bodily Lumens, for Example an Atrium", Preliminary Amendment filed in co-pending U.S. Appl. No. 14/713,114 dated Jun. 16, 2015, 8 pgs.
- Office Action issued in co-pending U.S. Appl. No. 14/521,692 dated Jan. 10, 2017.
- Gelbart et al., "Medical Device for Use in Bodily Lumens, for Example an Atrium", Amendment filed in co-pending U.S. Appl. No. 14/229,305 dated Sep. 27, 2016, 15 pgs.
- Notice of Allowance issued in co-pending U.S. Appl. No. 14/229,305 dated Nov. 8, 2016.
- Gelbart et al., "Medical Device for Use in Bodily Lumens, for Example an Atrium", Amendment Filed in co-pending U.S. Appl. No. 14/229,250 dated Sep. 27, 2016, 13 pgs.
- Notice of Allowance issued in co-pending U.S. Appl. No. 14/229,250 dated Dec. 7, 2016.

(56)

References Cited

OTHER PUBLICATIONS

- Moisa et al., "Catheter System", Amendment filed in co-pending U.S. Appl. No. 14/136,946 dated Apr. 18, 2016, 19 pgs.
- Lopes et al., "Enhanced Medical Device for Use in Bodily Cavities, for Example an Atrium", Amendment filed in co-pending U.S. Appl. No. 13/942,354 dated Jan. 4, 2017, 23 pgs.
- Lopes et al., "High-Density Electrode-Based Medical Device System", Preliminary Amendment filed in co-pending U.S. Appl. No. 13/793,076 dated May 26, 2016, 15 pgs.
- Lopes et al., "High-Density Electrode-Based Medical Device System", Amendment filed in co-pending U.S. Appl. No. 13/793,076 dated May 9, 2016, 15 pgs.
- Gelbart et al., "Apparatus and Method for Intracardiac Mapping and Ablation", Preliminary Amendment filed in co-pending U.S. Appl. No. 13/785,931 dated Mar. 5, 2013, 2 pgs.
- Gelbart et al., "Apparatus and Method for Intra-Cardiac Mapping and Ablation", Amendment filed in co-pending U.S. Appl. No. 13/785,910 dated Feb. 9, 2016, 11 pgs.
- Gelbart et al., "Apparatus and Method for Intra-Cardiac Mapping and Ablation", Amendment filed in co-pending U.S. Appl. No. 13/785,910 dated Jan. 5, 2016, 15 pgs.
- Gelbart et al., "Apparatus and Method for Intra-Cardiac Mapping and Ablation", Amendment filed in co-pending U.S. Appl. No. 13/785,910 dated Aug. 8, 2016, 18 pgs.
- Office Action issued in co-pending U.S. Appl. No. 13/785,910 dated Nov. 2, 2016.
- Amendment filed in copending U.S. Appl. No. 14/713,114, filed Aug. 23, 2017.
- Notice of Allowance issued in copending U.S. Appl. No. 14/713,190 dated Aug. 28, 2017.
- Office Action issued in copending U.S. Appl. No. 13/785,910 dated Aug. 30, 2017.
- Becker R. et al., "Ablation of Atrial Fibrillation: Energy Sources and Navigation Tools: A Review", *Journal of Electrocardiology*, 37 (Supplement 2004): 55-62, 2004.
- Calkins, Hugh, "Radiofrequency Catheter Ablation of Supraventricular Arrhythmias", *Heart*, 85:594-600, 2001.
- De Ponti et al., "Non-Fluoroscopic Mapping Systems for Electrophysiology: The 'Tool or Toy' Dilemma After 10 Years", *European Heart Journal* 27:1134-1136, 2006.
- Gelbart et al., "Apparatus and Method for Intra-Cardiac Mapping and Ablation", Office Action dated Dec. 13, 2013; Notice of Allowance dated Jul. 25, 2014 for U.S. Appl. No. 11/475,950, 19 pgs.
- Gelbart et al., "Medical Device for Use in Bodily Lumens, for Example an Atrium", Office Action dated Jan. 3, 2012; Office Action dated Apr. 3, 2014; Notice of Allowance dated Aug. 26, 2014 for U.S. Appl. No. 11/941,819, 35 pgs.
- Gelbart et al., "Apparatus and Method for Intra-Cardiac Mapping and Ablation", Amendment filed Apr. 10, 2014; Supplemental Amendment filed Feb. 12, 2013 for U.S. Appl. No. 11/475,950, 21 pgs.
- Gelbart et al., "Apparatus and Method for Intra-Cardiac Mapping and Ablation", Preliminary Amendment filed Aug. 22, 2014; Preliminary Amendment filed Mar. 5, 2013 for U.S. Appl. No. 13/785,910, 10 pgs.
- Gelbart et al., "Apparatus and Method for Intra-Cardiac Mapping and Ablation", Preliminary Amendment filed Aug. 22, 2014; Preliminary Amendment filed Mar. 5, 2013 for U.S. Appl. No. 13/785,931, 10 pgs.
- Lopes et al., "Enhanced Medical Device for Use in Bodily Cavities, for Example an Atrium", Preliminary Amendment filed Oct. 22, 2013 for U.S. Appl. No. 13/942,354, 13 pgs.
- Lopes et al., "Enhanced Medical Device for Use in Bodily Cavities, for Example an Atrium", Preliminary Amendment filed Aug. 20, 2014 for U.S. Appl. No. 13/782,889, 11 pgs.
- Lopes et al., "Enhanced Medical Device for Use in Bodily Cavities, for Example an Atrium", Preliminary Amendment filed Mar. 14, 2013 for U.S. Appl. No. 13/782,867, 8 pgs.
- Gelbart et al., "Medical Device for Use in Bodily Lumens, for Example an Atrium", Amendment filed Jul. 3, 2014; Amendment filed Apr. 2, 2012; Amendment filed Mar. 1, 2012; Amendment filed Nov. 23, 2011; Replacement drawings filed Feb. 13, 2008 for U.S. Appl. No. 11/941,819, 78 pgs.
- Gelbart et al., "Medical Device for Use in Bodily Lumens, for Example an Atrium", Preliminary Amendment filed May 12, 2014; Preliminary Amendment filed May 2, 2014 for U.S. Appl. No. 14/229,305, 12 pgs.
- Gelbart et al., "Medical Device for Use in Bodily Lumens, for Example an Atrium", Preliminary Amendment filed May 12, 2014; Preliminary Amendment filed May 2, 2014 for U.S. Appl. No. 14/229,250, 10 pgs.
- Gelbart et al., Medical Device for Use in Bodily Lumens, for Example an Atrium, Amendment filed Sep. 22, 2014, for U.S. Appl. No. 13/070,215, 18 pgs.
- Gelbart et al., Medical Device for Use in Bodily Lumens, for Example an Atrium, Office Action dated Jun. 20, 2014, for U.S. Appl. No. 13/070,215, 8 pgs.
- Gelbart et al., "Medical Device for Use in Bodily Lumens, for Example an Atrium", Supplemental Notice of Allowance dated Oct. 6, 2014 for U.S. Appl. No. 11/941,819, 4 pgs.
- Notice of Allowance issued in U.S. Appl. No. 13/793,213 dated Aug. 10, 2016.
- Non-Final Office Action issued in U.S. Appl. No. 13/942,354 dated Aug. 4, 2016.
- Notice of Allowance issued in U.S. Appl. No. 14/136,946 dated May 12, 2016.
- Notice of Allowance issued in U.S. Appl. No. No. 13/782,867 dated Aug. 12, 2016.
- Notice of Allowance issued in U.S. Appl. No. 13/782,903 dated Jul. 6, 2016.
- Corrected Notice of Allowance issued in U.S. Appl. No. 13/782,903 dated Jul. 19, 2016.
- Non-Final Office Action issued in U.S. Appl. No. 14/229,305, dated Apr. 29, 2016.
- Notice of Allowance issued in U.S. Appl. No. 29/509,621, dated Sep. 27, 2016.
- Notice of Allowance issued in U.S. Appl. No. 29/509,636, dated Sep. 27, 2016.
- Bard, "Mesh Ablator Catheter", Brochure, 2008, 4 pgs, Bard Electrophysiology Division, C.R. Bard Inc., 55 Technology Drive Lowell, MA 07851 USA.
- Biotronik's "AICath Flutter Gold Cath for Atrial Flutter Available in EU", Sep. 19, 2013, medGadget, 3 pgs, <http://www.medgadget.com/2013/09/biotroniks-alcath-flutter-gold-cath-for-atrial-flutter-unveiled-in-europe.html> [Jun. 24, 2014 2:37:09 PM].
- "Constellation Mapping Catheters", Brochure, Boston Scientific Corp., 2 pgs © 2007 Boston Scientific Corporation.
- "Waveforms and Segments", Ensite System Instructions for use, 54-06154-001 Rev02, Chapter 7 pp. 85-90 © 2007 St. Jude Medical.
- Extended European Search Report and EP search opinion for EP 12736677.1, dated Mar. 28, 2014, corresponding to PCT/US2012/022061.
- Extended European Search Report and EP search opinion for EP 12736962.7, dated Mar. 28, 2014, corresponding to PCT/US2012/022062.
- Extended European Search Report dated Aug. 20, 2013 issued in EP Patent Application No. 13172848.7.
- Written Opinion dated Aug. 22, 2012 for PCT/US2012/022061, 6 pgs.
- International Search Report and Written Opinion dated Aug. 2, 2013 issued in PCT/CA2013/050350.
- International Search Report and Written Opinion dated Sep. 17, 2013 issued in PCT/US2013/039982.
- International Search Report and Written Opinion dated Sep. 27, 2013 issued in PCT/US2013/039977.
- International Search Report dated Jul. 30, 2012 for PCT/US2012/022062, 5 pgs.
- Written Opinion dated Jul. 30, 2012 for PCT/US2012/022062, 5 pgs.
- International Search Report dated Aug. 22, 2012 for PCT/US2012/022061, 5 pgs.

(56) **References Cited**

OTHER PUBLICATIONS

- "Phased RF Catheter Ablation System", 2014 Medtronic Inc., 2 pgs, <http://www.medtronic.eu/your-health/atrial-fibrillation/about-the-therapy/our-phased-rf-ablation-system/>[Jun. 24, 2014 2:38:05 PM].
- "ThermoCool® Irrigated Tip Catheter", Brochure, Biosense Webster, 4 pgs, Biosense Webster, Inc. 3333 Diamond Canyon Road Diamond Bar, CA 91765, USA, © Biosense Webster, Inc. 2009 All rights reserved. 1109003.0.
- Gelbart "Medical Device for Use in Bodily Lumens, for Example an Atrium", OA mailed Jul. 25, 2011 for U.S. Appl. No. 11/941,819, now published as US 2009-0131930 A1.
- Gelbart et al, "Apparatus and Method for Intra-Cardiac Mapping and Ablation", Notice of Allowance dated Oct. 23, 2014 for U.S. Appl. No. 11/475,950, 10 pgs.
- Gelbart et al., "Medical Device for Use in Bodily Lumens, for Example an Atrium", Notice of Allowance dated Nov. 13, 2014 for U.S. Appl. No. 13/070,215, 54 pages.
- International Search Report dated Mar. 10, 2015, for International Application PCT/CA2014/051144; 10 pages.
- Written Opinion dated Mar. 10, 2015, for International Application PCT/CA2014/051144; 4 pages.
- Official Action issued in CN201280004400.9, dated Dec. 3, 2014.
- Non-final Office Action issued in U.S. Appl. No. 13/782,867, dated Apr. 15, 2015.
- Non-final Office Action issued in U.S. Appl. No. 13/782,903, dated Apr. 28, 2015.
- Lopes et al., "Enhanced Medical Device for Use in Bodily Cavities, for Example an Atrium", Office Action dated May 22, 2015 for U.S. Appl. No. 13/782,889, 86 pages.
- Lopes et al., "High-Density Electrode-Based Medical Device System", Office Action dated Jul. 10, 2015 for U.S. Appl. No. 13/793,076, 98 pages.
- Lopes et al., "High-Density Electrode-Based Medical Device System", Office Action dated Jul. 9, 2015 for U.S. Appl. No. 13/793,213, 99 pages.
- Gelbart et al., "Apparatus and Method for Intra-Cardiac Mapping and Ablation", Office Action dated Aug. 5, 2015 for U.S. Appl. No. 13/785,910, 79 pages.
- Lopes et al., "Enhanced Medical Device for Use in Bodily Cavities, for Example an Atrium", Amendment filed Aug. 24, 2015 for U.S. Appl. No. 13/782,889, 21 pages.
- Lopes et al., "Enhanced Medical Device for Use in Bodily Cavities, for Example an Atrium", Amendment filed Aug. 28, 2015 for U.S. Appl. No. 13/782,903, 19 pages.
- Lopes et al., "Enhanced Medical Device for Use in Bodily Cavities, for Example an Atrium", Amendment filed Sep. 14, 2015 for U.S. Appl. No. 13/782,867, 25 pages.
- Lopes et al., "High-Density Electrode-Based Medical Device System", Amendment filed Oct. 9, 2015 for U.S. Appl. No. 13/793,213, 26 pages.
- Lopes et al., "High-Density Electrode-Based Medical Device System", Amendment filed Oct. 9, 2015 for U.S. Appl. No. 13/793,076, 14 pages.
- Examination Report issued in EP13172848.7, dated Sep. 21, 2015.
- Extended European Search Report issued in EP13793216.6, dated Oct. 30, 2015.
- Moisa et al., "Catheter System", Office Action dated Nov. 16, 2015 for U.S. Appl. No. 14/136,946, 92 pages.
- Office Action issued in U.S. Appl. No. 13/782,889, dated Dec. 18, 2015.
- Office Action issued in U.S. Appl. No. 13/782,903, dated Dec. 18, 2015.
- Extended European Search Report issued in EP15188407.9, dated Jan. 21, 2016.
- Lopes et al. "Enhanced Medical Device for Use in Bodily Cavities, for Example an Atrium", Office Action dated Jan. 25, 2016 for U.S. Appl. No. 13/782,867, 49 pages.
- Notice of Allowance issued in U.S. Appl. No. 13/793,076, dated Feb. 10, 2016.
- Final Office Action issued in U.S. Appl. No. 13/793,213, dated Feb. 26, 2016.
- Non-Final Office Action issued in U.S. Appl. No. 29/509,719, dated Feb. 25, 2016.
- Quayle issued in U.S. Appl. No. 29/509,621, dated Feb. 26, 2016.
- Quayle issued in U.S. Appl. No. 29/509,636, dated Feb. 26, 2016.
- Non-Final Office Action issued in U.S. Appl. No. 13/785,910 dated Apr. 8, 2016.
- Non-Final Office Action issued in U.S. Appl. No. 14/229,250 dated Apr. 28, 2016.
- Notice of Allowance issued in U.S. Appl. No. 13/793,076 dated Jul. 7, 2016.
- Summons to Attend Oral Proceedings issued in European Appln. No. 13172848.7, dated Sep. 1, 2016.
- Preliminary Amendment filed in copending U.S. Appl. No. 16/407,379 dated Jun. 12, 2019.
- Notice of Intention to Grant issued in EP Appln. No. 13793216.6 dated Jul. 15, 2019.
- Copending U.S. Appl. No. 16/521,712, filed Jul. 25, 2019 (a copy is not included because the cited application is not yet available to the public and the Examiner has ready access to the cited application).
- Copending U.S. Appl. No. 16/521,732, filed Jul. 25, 2019 (a copy is not included because the cited application is not yet available to the public and the Examiner has ready access to the cited application).
- Copending U.S. Appl. No. 16/521,745, filed Jul. 25, 2019 (a copy is not included because the cited application is not yet available to the public and the Examiner has ready access to the cited application).
- Preliminary Amendment filed in copending U.S. Appl. No. 16/521,712 dated Jul. 25, 2019.
- Preliminary Amendment filed in copending U.S. Appl. No. 16/521,732 dated Jul. 25, 2019.
- Preliminary Amendment filed in copending U.S. Appl. No. 16/521,745 dated Jul. 25, 2019.
- Amendment filed in copending U.S. Appl. No. 15/254,130 dated Aug. 13, 2019.
- Second Preliminary Amendment filed in copending U.S. Appl. No. 16/521,712 dated Aug. 15, 2019.
- Second Preliminary Amendment filed in copending U.S. Appl. No. 16/521,732 dated Aug. 15, 2019.
- Second Preliminary Amendment filed in copending U.S. Appl. No. 16/521,745 dated Aug. 15, 2019.
- Notice of Intention to Grant issued in EP Appln. No. 14871405.8 dated Jan. 22, 2019.
- Notice of Intention to Grant issued in EP Appln. No. 15188407.9 dated Mar. 20, 2019.
- Copending U.S. Appl. No. 16/369,528, filed Mar. 29, 2019 (a copy is not included because the cited application is not yet available to the public and the Examiner has ready access to the cited application).
- Copending U.S. Appl. No. 16/381,317, filed Apr. 11, 2019 (a copy is not included because the cited application is not yet available to the public and the Examiner has ready access to the cited application).
- Copending U.S. Appl. No. 16/381,344, filed Apr. 11, 2019 (a copy is not included because the cited application is not yet available to the public and the Examiner has ready access to the cited application).
- Preliminary Amendment filed in copending U.S. Appl. No. 16/369,528 dated Apr. 24, 2019.
- Preliminary Amendment filed in copending U.S. Appl. No. 16/381,317 dated Apr. 24, 2019.
- Preliminary Amendment filed in copending U.S. Appl. No. 16/381,344 dated Apr. 24, 2019.
- Copending U.S. Appl. No. 16/407,379, filed May 9, 2019 (a copy is not included because the cited application is not yet available to the public and the Examiner has ready access to the cited application).

(56)

References Cited

OTHER PUBLICATIONS

Office Action issued in copending U.S. Appl. No. 15/254,130 dated
May 28, 2019.

* cited by examiner

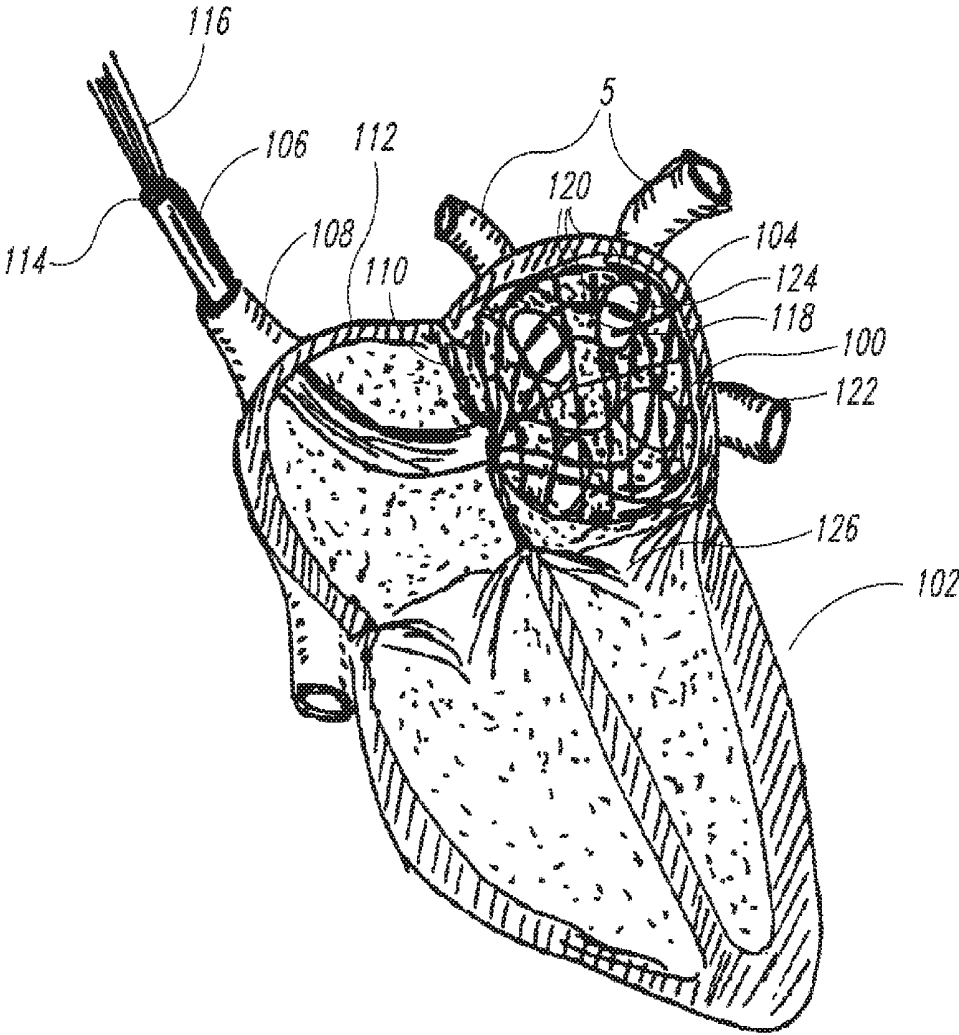

FIG. 1

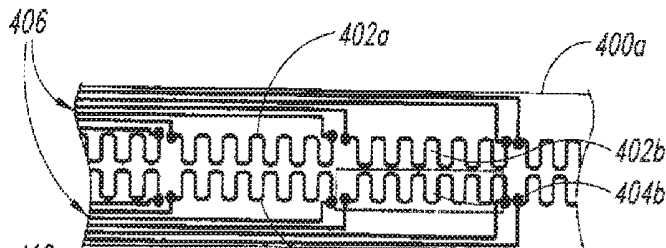

FIG. 4A

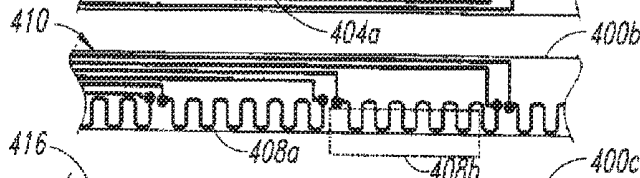

FIG. 4B

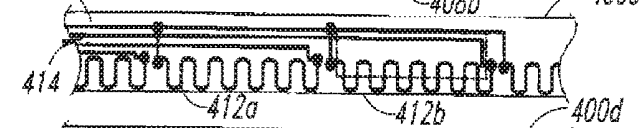

FIG. 4C

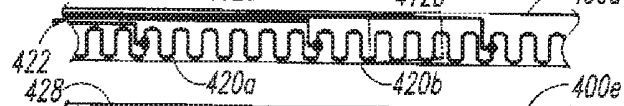

FIG. 4D

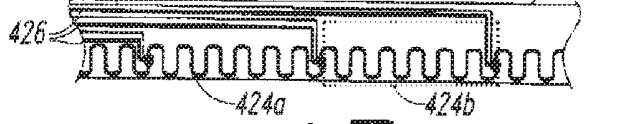

FIG. 4E

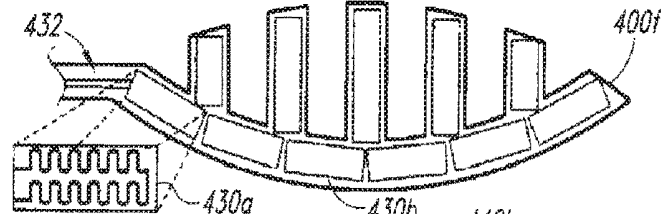

FIG. 4F

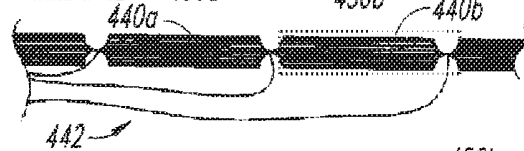

FIG. 4G

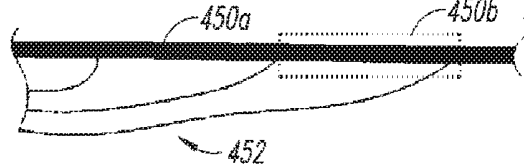

FIG. 4H

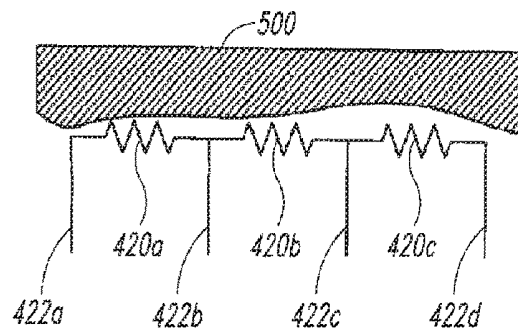

FIG. 5

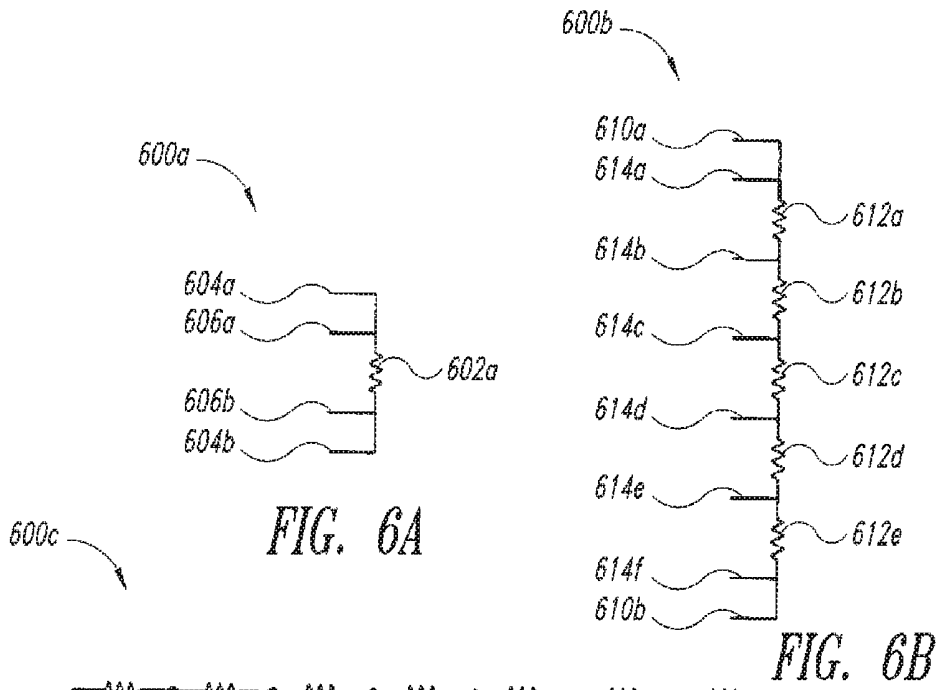

FIG. 6A

FIG. 6B

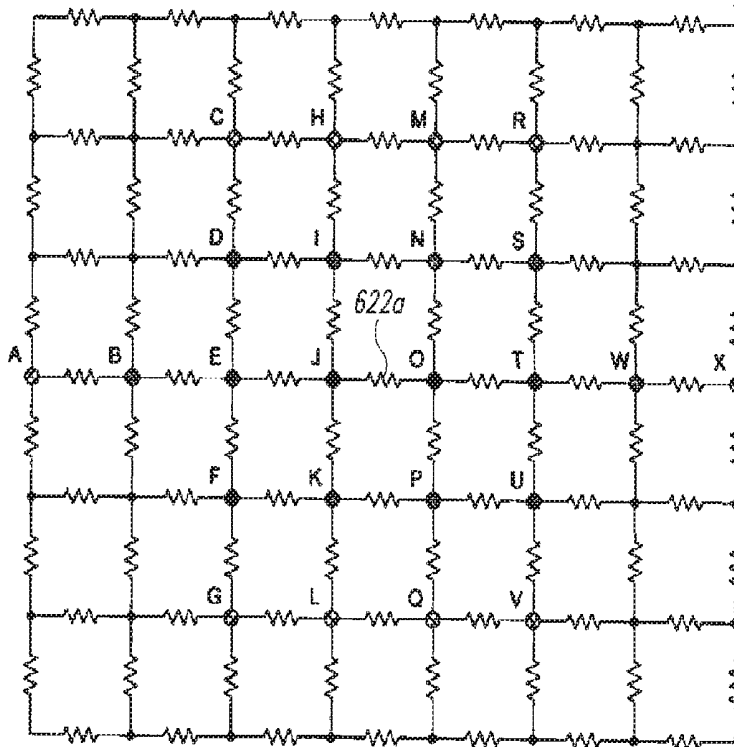

FIG. 6C

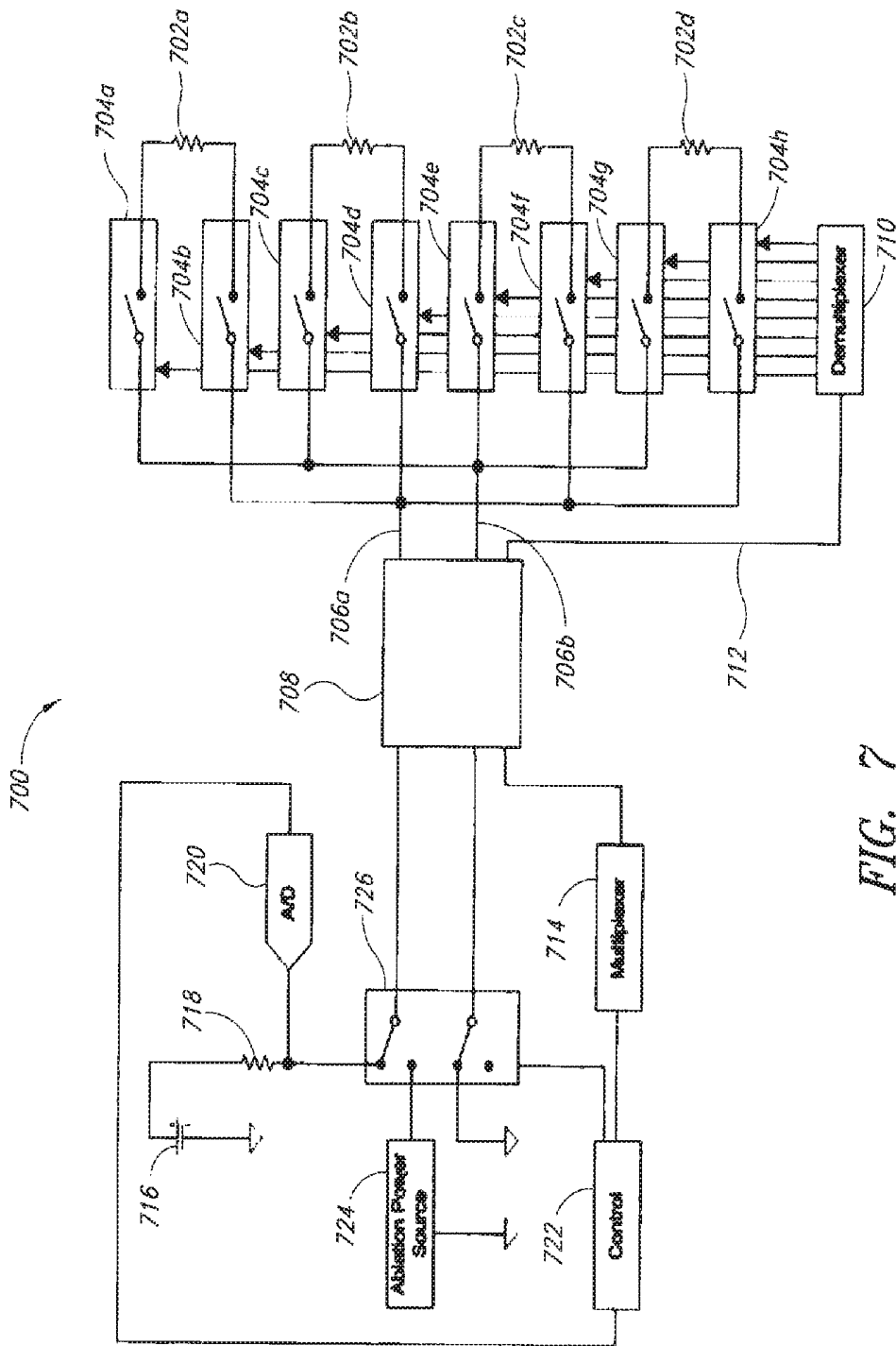

FIG. 7

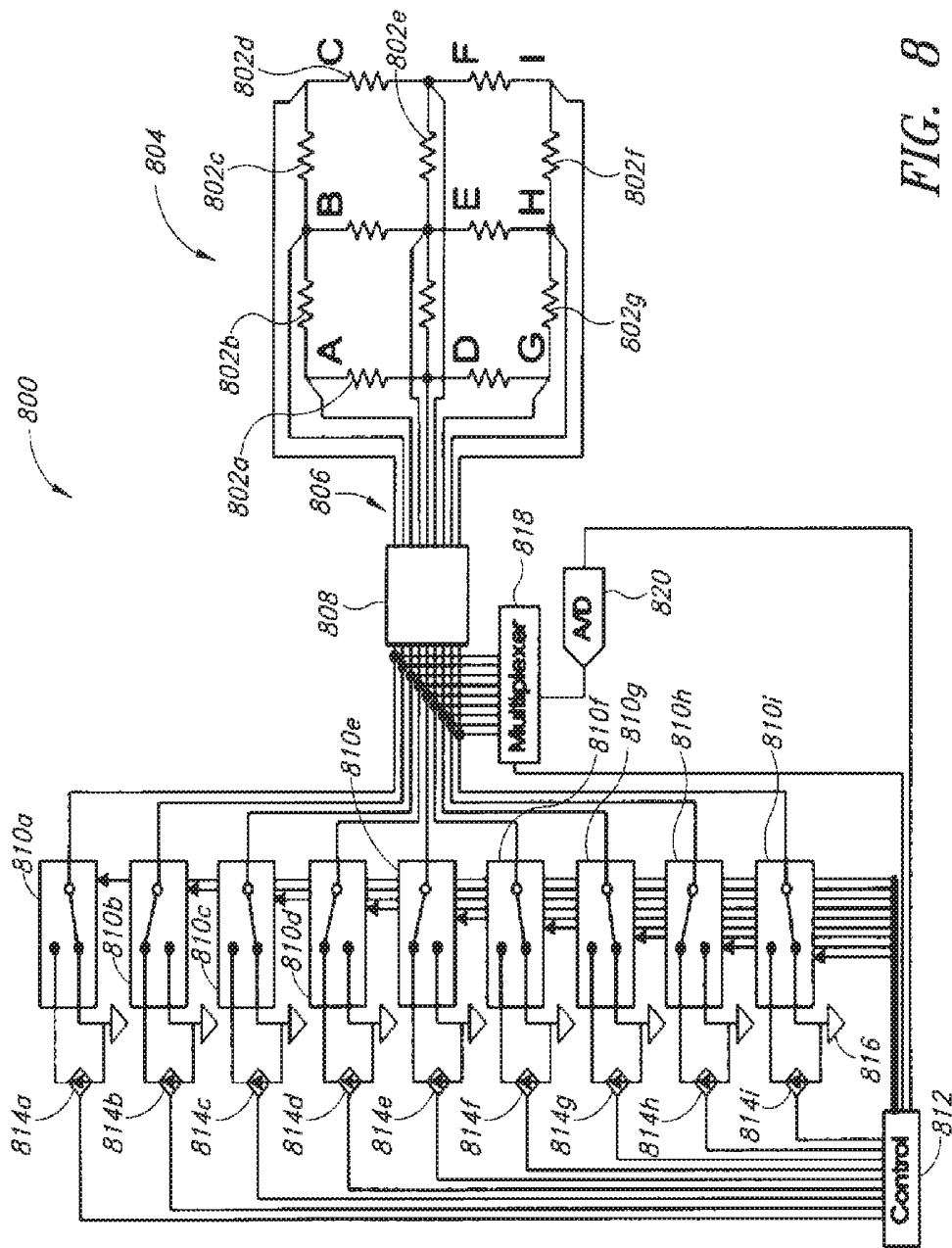

FIG. 8

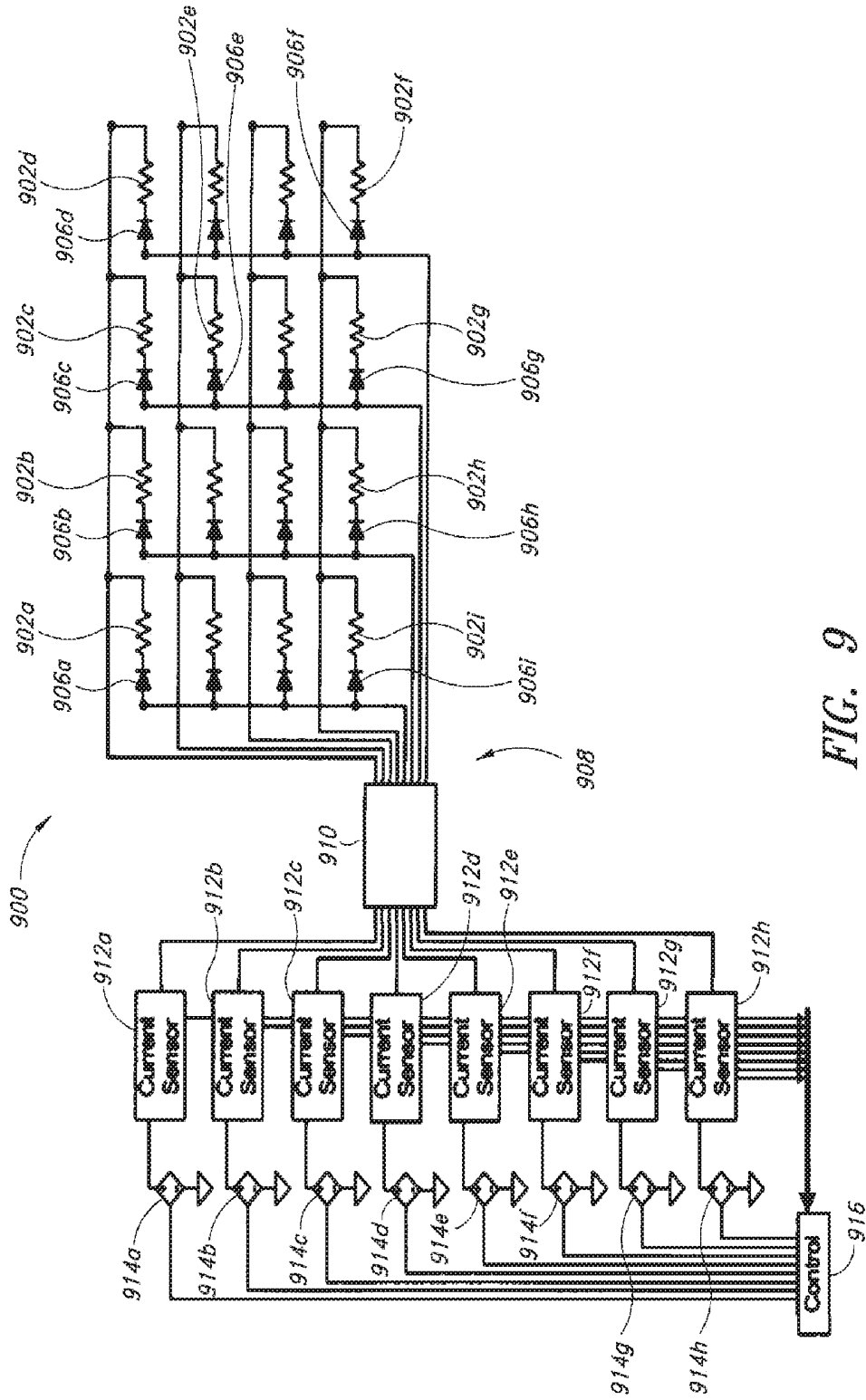

FIG. 9

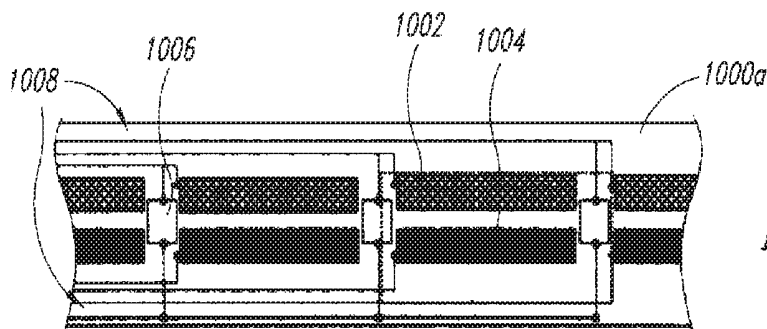

FIG. 10A

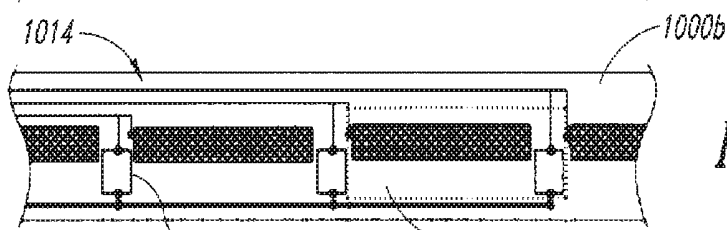

FIG. 10B

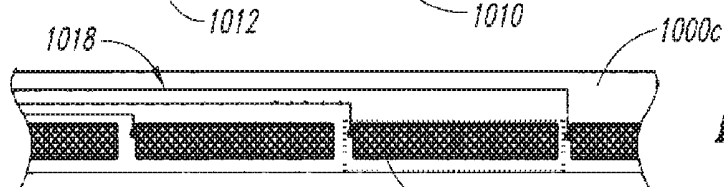

FIG. 10C

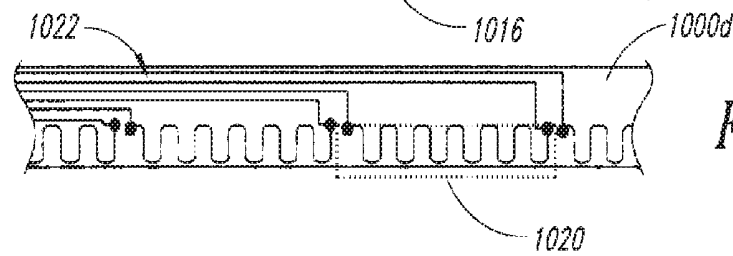

FIG. 10D

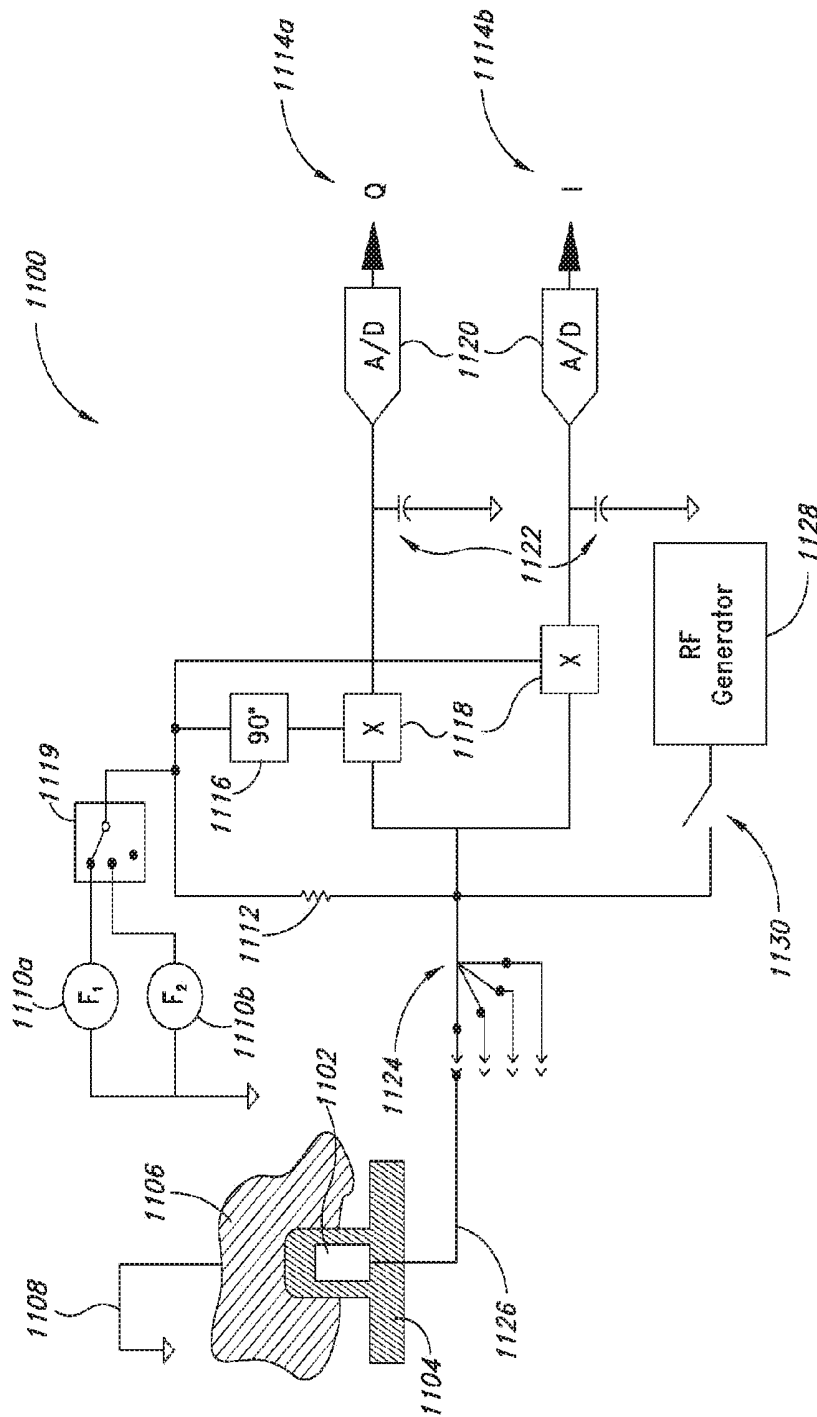

FIG. 11

FIG. 12A

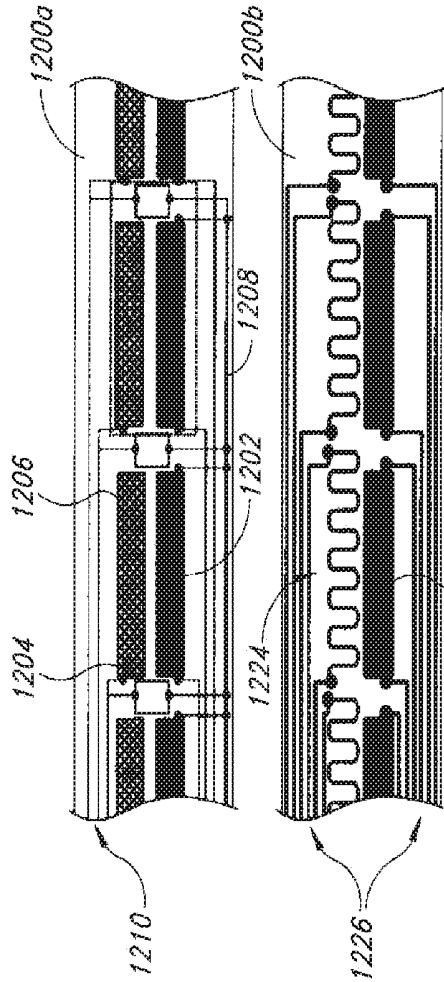

FIG. 12B

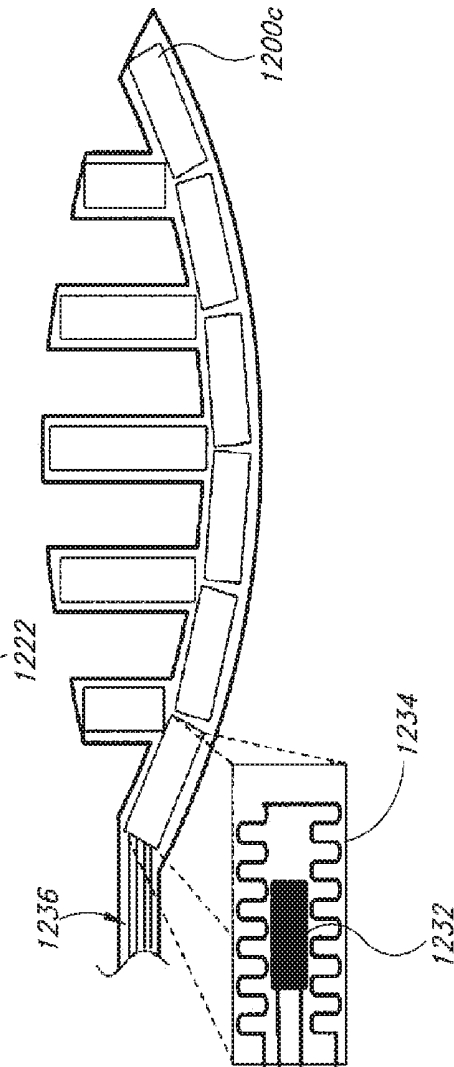

FIG. 12C

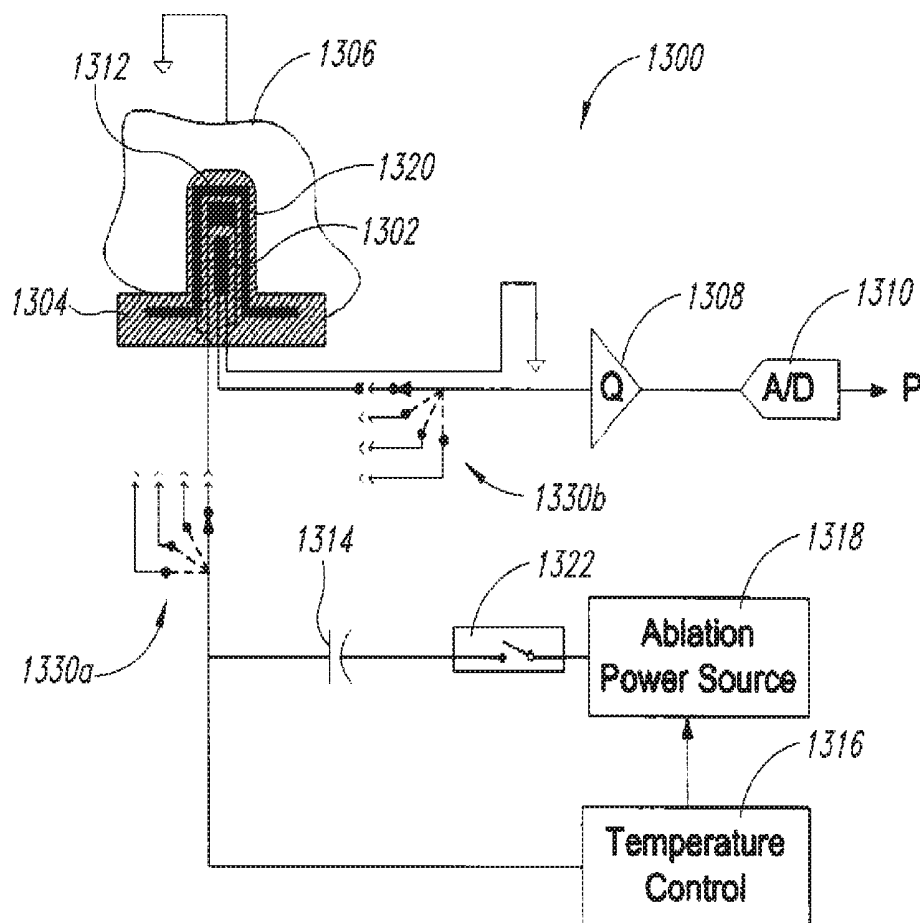

FIG. 13

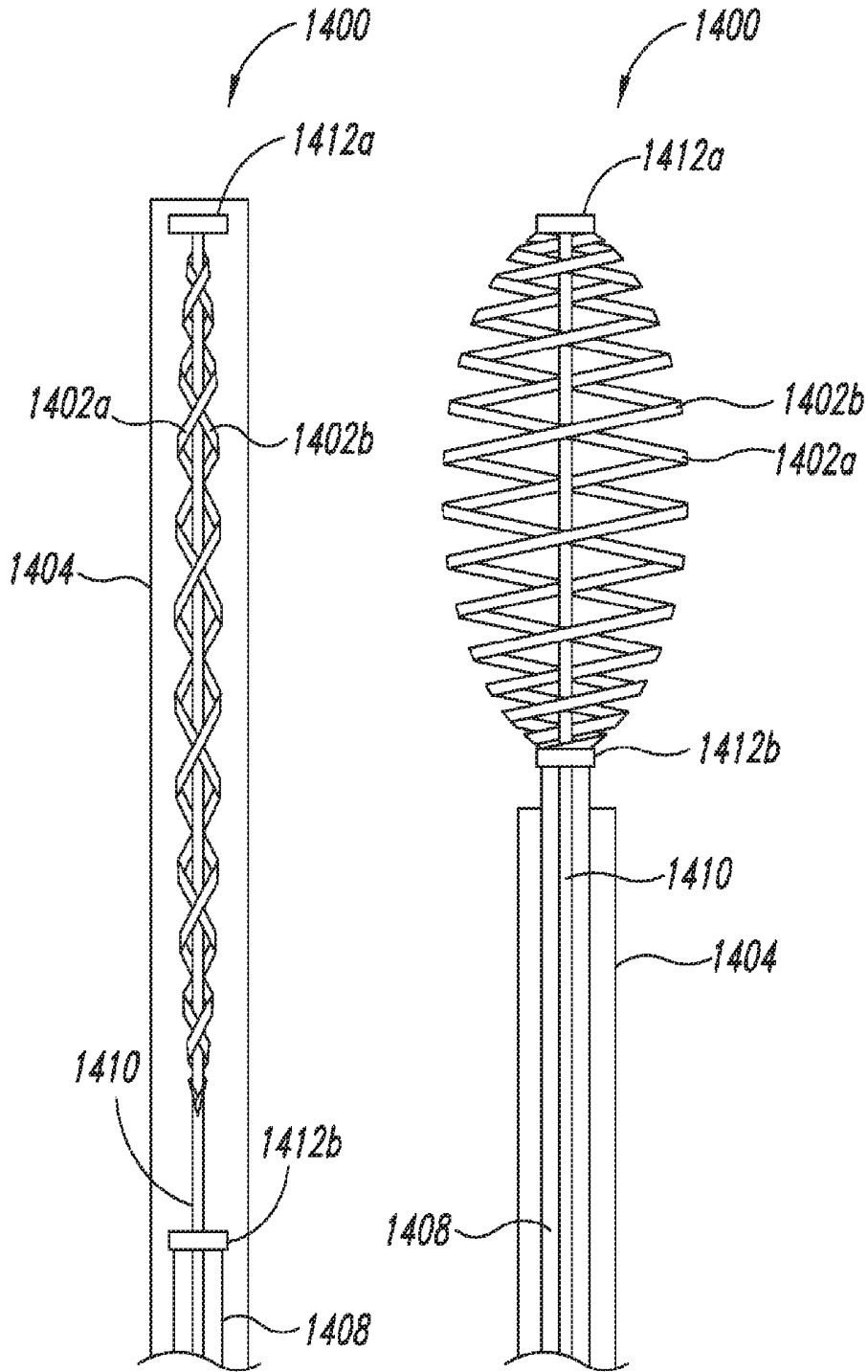

FIG. 14A

FIG. 14B

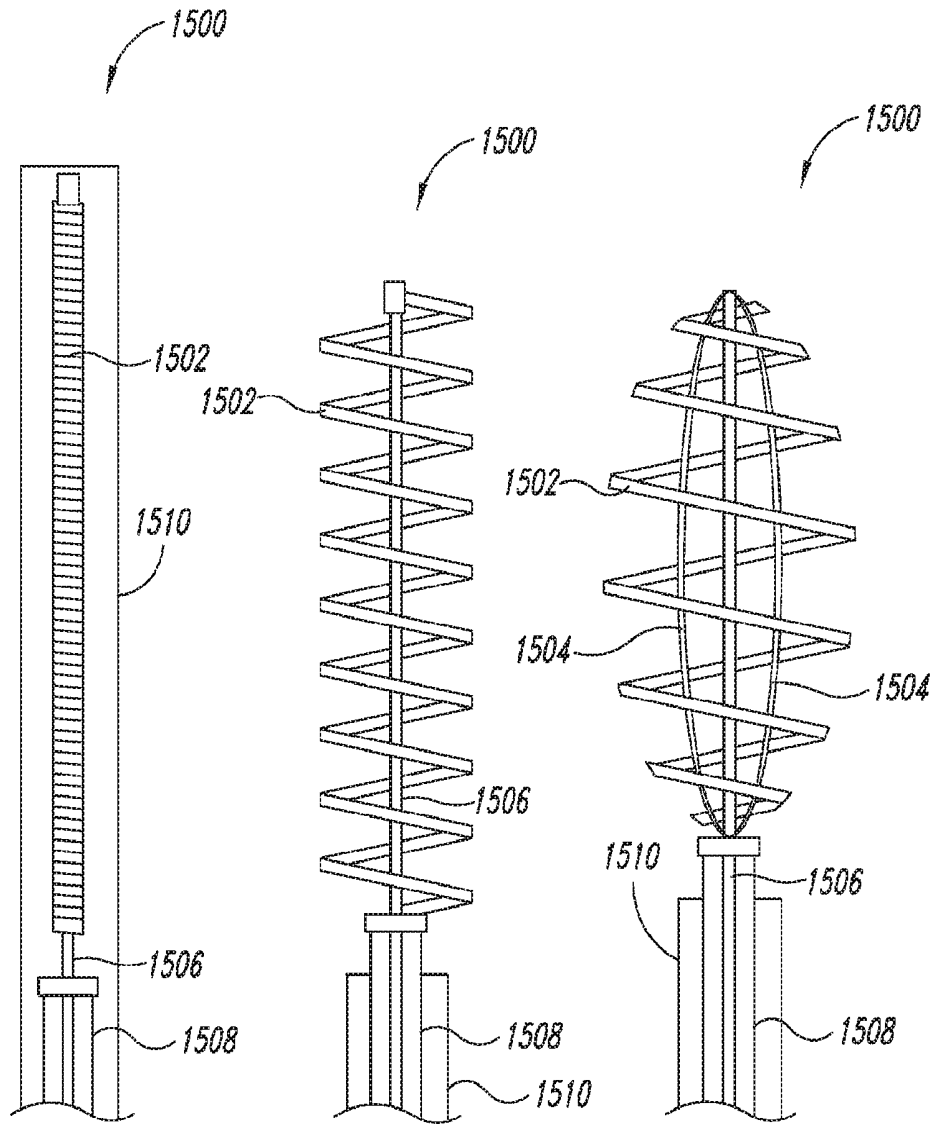

FIG. 15A

FIG. 15B

FIG. 15C

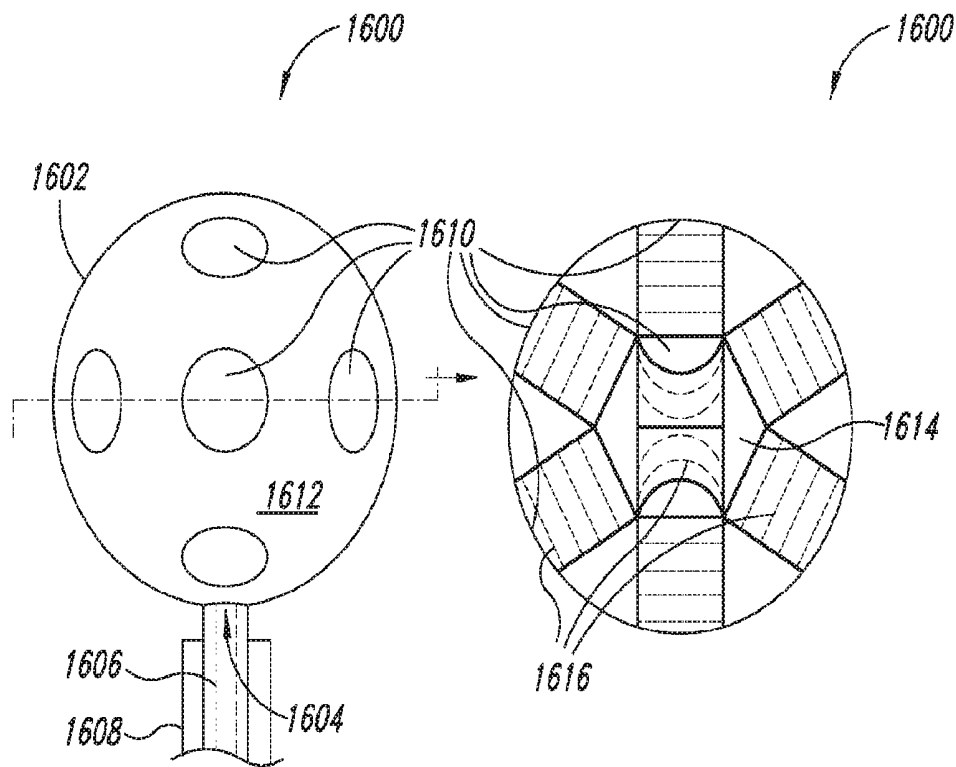
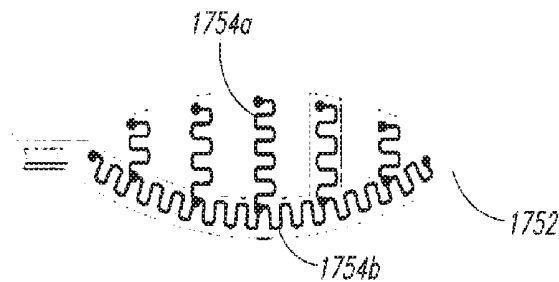
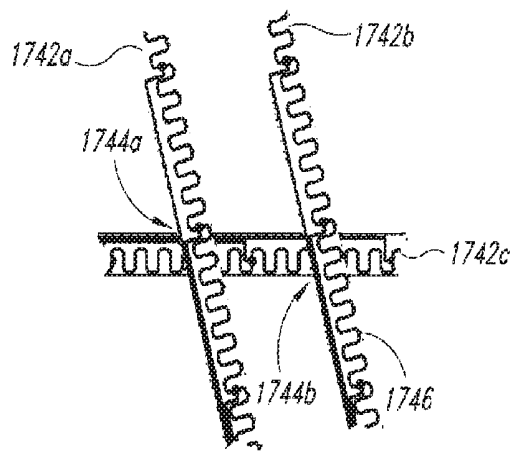
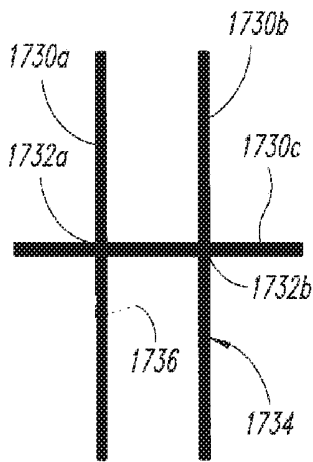
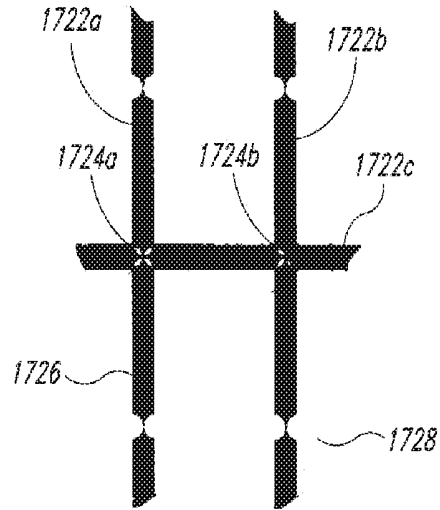
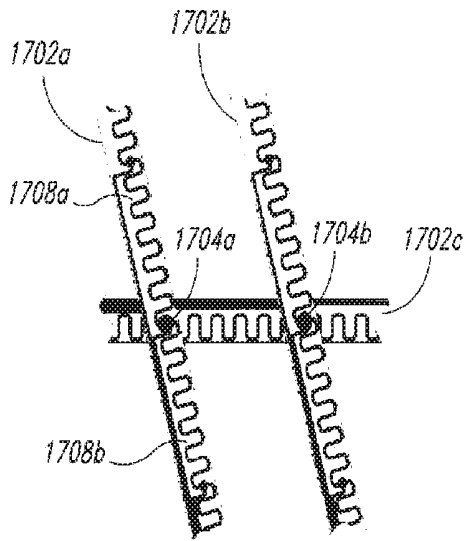

FIG. 16A

FIG. 16B



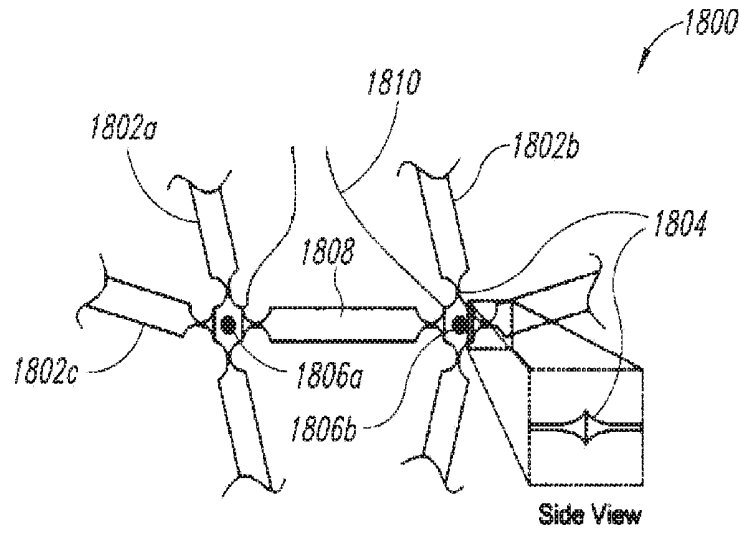

FIG. 18A

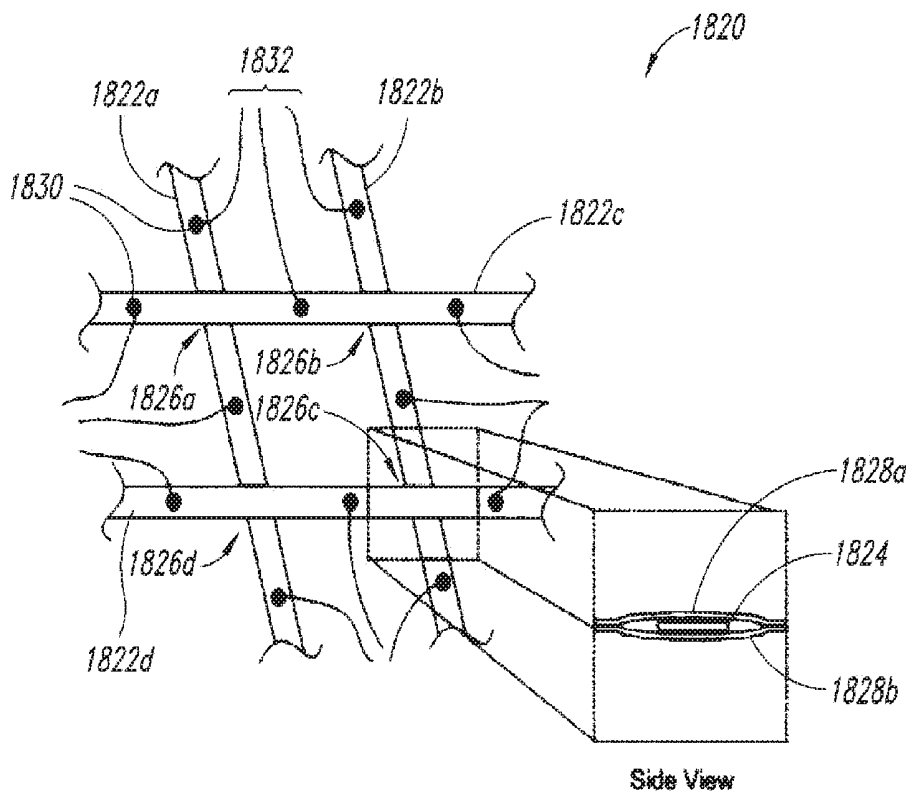

FIG. 18B

MEDICAL DEVICE FOR USE IN BODILY LUMENS, FOR EXAMPLE AN ATRIUM

CROSS-REFERENCE TO RELATED APPLICATION

This application is a continuation of U.S. patent application Ser. No. 14/521,692, filed Oct. 23, 2014, now U.S. Pat. No. 9,750,569, which is a divisional of U.S. patent application Ser. No. 11/941,819, filed Nov. 16, 2007, now U.S. Pat. No. 8,906,011, issued Dec. 9, 2014, the contents of the applications cited in this sentence are hereby incorporated herein by reference.

BACKGROUND

Field

This disclosure is generally related to percutaneous cardiac surgery, and more particularly to percutaneously deployed medical devices suitable for determining locations of cardiac features and/or ablating regions of cardiac tissue.

Description of the Related Art

Cardiac surgery was initially undertaken only by performing a sternotomy, a type of incision in the center of the chest, that separates the sternum (chestbone) to allow access to the heart. In the previous several decades, more and more cardiac operations are performed using percutaneous techniques, that is medical procedures where access to inner organs or other tissue is gained via a catheter.

Percutaneous surgeries benefit patients by reducing surgery risk, complications and recovery time. However, the use of percutaneous technologies also raises some particular challenges. Medical devices used in percutaneous surgery need to be deployed via narrow tubes called catheter sheaths, which significantly increase the complexity of the device structure. As well, doctors do not have direct visual contact with the medical tools used once they are placed within the body, and positioning the tools correctly and operating the tools successfully can often be very challenging.

One example of where percutaneous medical techniques are starting to be used is in the treatment of a heart disorder called atrial fibrillation. Atrial fibrillation is a disorder in which spurious electrical signals cause an irregular heart beat. Atrial fibrillation has been treated successfully in open heart methods using a technique known as the "Maze procedure". During this procedure, doctors create lesions in a specific pattern in the left and right atria that eliminate the spurious electrical signals. Such lesions were originally created using incisions, but are now typically created by ablating the tissue with RF energy. The procedure is performed with a high success rate under direct vision, but is relatively complex to perform percutaneously because of the difficulty in creating the lesions in the correct spots. Substantial problems, potentially leading to severe adverse results, may occur if the lesions are placed incorrectly.

Key factors which are needed to dramatically improve the percutaneous treatment of atrial fibrillation are enhanced methods for deployment, positioning, and operation of the treatment device. It is particularly important to know the position of the elements which will be creating the lesions relative to cardiac features such as the pulmonary veins and mitral valve.

Several methods have been previously developed for positioning percutaneously deployed medical devices with the heart. However, there are significant challenges associated with each of these methods. One method is to map the inside of the atrium by sensing electrical activity on the

atrium wall. Devices that use such a method require intimate electrical contact with the atrium wall which is not always possible because of scar tissue and deposits. Also, such devices fail to accurately map the edges of the openings where the veins enter the atrium, which is important for correct placement of the ablation pattern. Other methods, such as using an array of ultrasonic transducers, are not practical as devices that make use of such methods will not fit through a catheter of a reasonable size (6-8 mm diameter). Yet another method for positioning the treatment device is to make use of an external system for providing navigation, such as a magnetic positioning system. These systems are very expensive and have difficulty delivering the resolution and accuracy needed for correct placement of ablation.

Atrial fibrillation is but one example of a cardiac surgery that requires improved navigation and deployment for percutaneous treatment. There are many others that require similar improvement, such as mitral valve repair.

Thus, there is a need for methods and apparatus that improve navigation and percutaneous deployment of medical devices, as well as determination of the relative position of cardiac features such as pulmonary veins and the mitral valve with respect to a medical device. There is a further need for methods and apparatus that allow the formation of lesions in a specified position relative to cardiac features such as pulmonary veins and the mitral valve.

BRIEF SUMMARY OF THE INVENTION

The present design of a medical device with enhanced capabilities for deployment, positioning and ablating within the heart employs a method for distinguishing tissue from blood and may be used to deliver superior positional information of the device relative to ports in the atrium, such as the pulmonary veins and mitral valve. The device may employ methods such as blood flow detection, impedance change detection or deflection force detection to discriminate between blood and tissue. The device may also improve ablation positioning and performance by using the same elements for discriminating between blood and tissue as are used for ablation. Other advantages will become apparent from the teaching herein to those of skill in the art.

At least one embodiment may be summarized as a method of operating a medical system including sensing at least one characteristic by each of a number of transducer elements carried by a device located in at least a portion of a bodily organ, the at least one characteristic indicative of at least one of a presence of a fluid (e.g., blood) and a presence of non-fluid tissue (e.g., wall of heart); computationally discriminating between the fluid and the non-fluid tissue based at least in part on the at least one characteristic sensed by at least some of the transducer elements; and providing information indicative of at least a position of the device in the bodily organ based on the computational discrimination between the fluid and the non-fluid tissue.

The method may further include ablating a portion of the non-fluid tissue in a bodily organ, for example the heart. The method may further include sensing an electrical potential of the non-blood tissue in the heart at least once after the ablating; and producing an indication based on the sensed electrical potential of the non-blood tissue indicative of whether the ablating was successful. Sensing at least one characteristic by each of a number of transducer elements may include sensing a permittivity of the fluid or the non-fluid tissue at each of a plurality of frequencies. Sensing at least one characteristic by each of a number of transducer elements may include sensing a force exerted on the sensor

by the fluid or non-fluid tissue. Providing information indicative of at least a position of the device in the bodily organ based on the computational discrimination between the fluid and the non-fluid tissue may include providing information indicative of a three-dimensional pose of the device with respect to at least the portion of a heart. The method may further include intravascularly guiding the device to a desired position while at least a portion of the device is in an unexpanded configuration; selectively moving at least the portion of the device into an expanded configuration to position the transducer elements at least proximate the non-fluid tissue; selectively moving at least the portion of the device into the unexpanded configuration; and intravascularly retrieving the device from the desired position while at least a portion of the device is in the unexpanded configuration.

At least one embodiment may be summarized as a medical system including a device positionable in at least a portion of a bodily organ (e.g., a heart), the device including a plurality of transducer elements, at least some of the transducer elements responsive to at least one characteristic indicative of a presence of either a fluid (e.g., blood) or non-fluid tissue (e.g., wall of heart) a computing system having at least one processor and at least one memory that stores instructions, the computing system configured to computationally discriminate between the fluid and the non-fluid tissue based at least in part on the at least one characteristic sensed by at least some of the transducer elements; and at least one transducer configured to provide information indicative of at least a position of the device in the bodily organ based on the computational discrimination between the fluid and the non-fluid tissue.

The system may further include an ablation source, wherein at least some of the transducer elements may be coupled to an ablation source and selectively operable to ablate a portion of the non-fluid tissue in the heart. At least some of the transducer elements that are responsive to at least one characteristic indicative of a presence of either the fluid or the non-fluid tissue in the bodily organ may also be responsive to electrical potential of the non-fluid tissue. At least some of the transducer elements may be responsive to electrical potentials of the non-fluid tissue, and the computing system may be further configured to produce an indication indicative of whether the ablation was successful based on at least one sensed electrical potential of the non-fluid tissue. At least a portion of the device may be selectively moveable between an unexpanded configuration and an expanded configuration, the device sized to be delivered intravascularly when at least the portion of the device is in the unexpanded configuration, and the transducer elements positioned sufficient proximate the non-fluid tissue to sense the at least one characteristic in the expanded configuration. The system may further include a catheter having a proximal end and a distal end opposed to the proximal end, the device coupled to the catheter at the distal end thereof; at least one communications path communicatively coupling the transducer elements and the computing system, the communications path including a multiplexer and a demultiplexer, the multiplexer on a computing system side of the communications path and the demultiplexer on a device side of the communications path.

At least one embodiment may be summarized as a method of operating a device in at least a portion of a heart, including sensing at least one characteristic by each of a number of transducer elements carried by the device located in at least the portion of the heart, the at least one characteristic indicative of at least one of a presence of blood and

a presence of non-blood tissue; computationally discriminating between the blood and the non-blood tissue based at least in part on the at least one characteristic sensed by at least some of the transducer elements; providing information indicative of a position of the device in the heart based on the discrimination between the blood and the non-blood tissue; sensing an electrical potential of the non-blood tissue in the heart; and providing an indication based on the sensed electrical potential of the non-blood tissue.

The method may further include ablating a portion of the tissue in the heart, wherein sensing an electrical potential of the non-blood tissue in the heart may occur at least once after the ablating. The method may further include evaluating the sensed electrical potential of the non-blood tissue in the heart to determine whether the ablating was successful.

At least one embodiment may be summarized as a medical system including a device positionable in at least a portion of a heart, the device including a plurality of transducer elements at least some of the transducer elements responsive to at least one characteristic indicative of at least one of a presence of blood and a presence of non-blood tissue and at least some of the transducer elements responsive to an electrical potential of the non-blood tissue in the heart; a computing system having at least one processor and at least one memory that stores instructions, the computing system configured to computationally discriminate between the blood and the non-blood tissue based at least in part on the at least one characteristic sensed by at least some of the transducer elements; and at least one transducer configured to provide information indicative of a position of the device in the heart based on the computational discrimination between the blood and the non-blood tissue and provide an indication based on the sensed electrical potential of the non-blood tissue.

The system may further include an ablation source, wherein at least some of the transducer elements may be coupled to an ablation source and selectively operable to ablate a portion of the non-blood tissue in the heart. The system may further include a switch operable to selectively couple the transducer elements between an ablation mode and a sense mode, where the transducer elements may ablate the non-blood tissue in the ablation mode and may sense the at least one characteristic in the sense mode. At least some of the transducer elements that are responsive to at least one characteristic indicative of a presence of either blood or non-blood tissue may also be responsive to electrical potential of the non-blood tissue. At least a portion of the device may be selectively moveable between an unexpanded configuration and an expanded configuration, the device sized to be delivered intravascularly when at least the portion of the device is in the unexpanded configuration, and the device sized to position the transducer elements sufficiently proximate the non-blood tissue to sense the at least one characteristic in the expanded configuration. The transducer elements may include at least one of a conductive trace on a flexible electrically insulative substrate, a conductive wire, a conductive tube, a carbon fiber material and a polymeric piezoelectric material. The device may include a number of flexible electrically insulative substrates that deform between an unexpanded configuration and an expanded configuration.

At least one embodiment may be summarized as a device to be inserted intravascularly, including a shaft moveable with respect to a catheter member; at least a first helical member configured to move between a radially unexpanded configuration and a radially expanded configuration in response to the movement of the shaft with respect to the

catheter, the device sized to be delivered intravascularly when at least the first helical member is in the unexpanded configuration; and a plurality of transducer elements that move in response to the movement of the first helical member between the radially unexpanded configuration and the radially expanded configuration, at least some of the transducer elements responsive to a characteristic of at least one of a fluid and a non-fluid tissue.

The device may further include at least a second helical member configured to move between a radially unexpanded configuration and a radially expanded configuration in response to the movement of the shaft with respect to the catheter. The first helical member may carry some of the transducer elements and the second helical member may carry some of the transducer elements. The first helical member may be disposed radially spaced about the shaft. The first helical member may be wound in one of a clockwise or a counterclockwise orientation with respect to the shaft and the second helical member may be wound in the other of the clockwise or the counterclockwise orientation with respect to the shaft. The device may further include a number of elongated ribs physically coupled between a proximate and a distal end of the first helical member. The elongated ribs may each form a respective flexible electrically insulative substrate and at least some of the transducer elements may comprise respective electrically conductive traces carried by the flexible electrically insulative substrate. The shaft may be axially moveable with respect to the catheter member between an extended position and a withdrawn position, a distal end of the shaft spaced relatively closer to an end of the catheter member in the withdrawn position than in the extended position, where the first helical member is in the unexpanded configuration when the shaft is in the extended position and is in the expanded configuration when the shaft is in the withdrawn position. The shaft may be rotatably moveable with respect to the catheter member between an extended position and a withdrawn position, a distal end of the shaft spaced relatively closer to an end of the catheter member in the withdrawn position than in the extended position, where the first helical member is in the unexpanded configuration when the shaft is in the extended position and is in the expanded configuration when the shaft is in the withdrawn position. The shaft may extend at least partially through a lumen of the catheter member to allow manipulation of the device from a position externally located from a patient. At least some of the transducer elements may be responsive to convective cooling from a flow of blood over the transducer elements. At least some of the transducer elements may be responsive to a permittivity at each of a plurality of frequencies. At least some of the transducer elements may be responsive to a force. At least some of the transducer elements may comprise a polymeric piezoelectric material. At least some of the transducer elements may be responsive to an electrical potential of a portion of the non-blood tissue. At least some of the transducer elements may include an electrically conductive trace carried by a flexible electrically insulative substrate. The first helical member may form a flexible electrically insulative substrate and at least some of the transducer elements may comprise respective electrically conductive traces carried by the flexible electrically insulative substrate. At least some of the transducer elements may include an electrically conductive wire. At least some of the transducer elements may include an electrically conductive tube. At least some of the transducer elements may include an electrically conductive carbon fiber.

At least one embodiment may be summarized as a method of operating a device including at least a first helical member and a plurality of transducer elements that are responsive to at least one characteristic of non-blood tissue, comprising: guiding a device in an unexpanded configuration intravascularly to a desired position; and expanding at least the first helical member of the device into an expanded configuration such that the plurality of transducer elements are positioned to sense the at least one characteristic over a substantial portion of the non-blood tissue.

The expanding at least the first helical member may include axially moving a shaft that extends at least partially through a lumen of a catheter member in a first direction. The expanding at least first helical member may include rotatably moving a shaft that extends at least partially through a lumen of a catheter member in a first direction. The method may further include retracting at least the first helical member into the unexpanded configuration; and intravascularly guiding the device in the unexpanded configuration to remove the device. The retracting at least the first helical member into the unexpanded configuration may include at least one of axially or radially moving the shaft that extends at least partially through the lumen of the catheter member in an opposite direction than moved when expanded.

At least one embodiment may be summarized as a medical device, including at least a first inflatable member having at least one chamber and at least one port that provides fluid communication with the chamber, the first inflatable member configured to move between an unexpanded configuration and an expanded configuration in response to a change of a pressure in the chamber, the device sized to be delivered intravascularly when at least the first inflatable member is in the unexpanded configuration; a plurality of transducer elements that move in response to the movement of the first inflatable member between the radially unexpanded configuration and the radially expanded configuration, at least some of the transducer elements responsive to a characteristic of at least one of a fluid and a non-fluid tissue.

The first inflatable member may have at least one passage that provides fluid communication across the first inflatable member. The at least one passage may provide fluid communication between an upstream position and a downstream position with respect to a position of the inflatable member when positioned in a cardiovascular structure. The at least one passage may be formed by a reinforced portion of the first inflatable member. The reinforced portion of the first inflatable member may include at least a rib, an elastic member, and a thickened portion of a wall that forms the passage. The port may be coupled to a lumen of a catheter member to allow fluid communication with the chamber from a fluid reservoir that is externally located with respect to a patient. At least some of the transducer elements may be responsive to convective cooling from a flow of blood over the transducer elements. At least some of the transducer elements may be responsive to a permittivity at each of a plurality of frequencies. At least some of the transducer elements may be responsive to a force. At least some of the transducer elements may comprise a polymeric piezoelectric material. At least some of the transducer elements may be responsive to an electrical potential of a portion of the non-blood tissue. At least some of the transducer elements may include an electrically conductive trace carried by a flexible electrically insulative substrate. The first helical member may form a flexible electrically insulative substrate and at least some of the transducer elements may comprise respective electrically conductive traces carried by the flex-

ible electrically insulative substrate. At least some of the transducer elements may include an electrically conductive wire. At least some of the transducer elements may include an electrically conductive tube. At least some of the transducer elements may include an electrically conductive carbon fiber.

At least one embodiment may be summarized as a method of operating a device including at least a first inflatable member and a plurality of transducer elements that are responsive to at least one characteristic of non-blood tissue, comprising: guiding a device in an unexpanded configuration intravascularly to a desired position; and inflating at least the first inflatable member of the device into an expanded configuration such that the plurality of transducer elements are positioned to sense the at least one characteristic over a substantial portion of the non-blood tissue.

Inflating at least the first helical member may include providing a fluid to a chamber of the first inflatable member through a lumen of a catheter member. The method may further include deflating at least the first inflatable member into the unexpanded configuration; and intravascularly guiding the device in the unexpanded configuration to remove the device. Deflating at least the first helical member into the unexpanded configuration may include removing the fluid from the chamber through the lumen of the catheter member.

BRIEF DESCRIPTION OF THE DRAWINGS

In the drawings, identical reference numbers identify similar elements or acts. The sizes and relative positions of elements in the drawings are not necessarily drawn to scale. For example, the shapes of various elements and angles are not drawn to scale, and some of these elements are arbitrarily enlarged and positioned to improve drawing legibility. Further, the particular shapes of the elements as drawn, are not intended to convey any information regarding the actual shape of the particular elements, and have been solely selected for ease of recognition in the drawings.

FIG. 1 is a cutaway diagram of a heart showing a medical device according to one illustrated embodiment percutaneously placed in a left atrium of the heart.

FIG. 2 is a schematic diagram of a treatment system according to one illustrated embodiment, including, a control unit, a display, and a medical device having an expandable frame and a leaf shaped assembly of elements.

FIG. 3 is a broken isometric diagram of a portion of an atrium and a number of elements showing how the elements can sense convective cooling to locate a position of ports.

FIG. 4A is a top plan view of element construction for flow sensing.

FIG. 4B is a top plan view according to yet another illustrated embodiment

FIG. 4C is a top plan view according to yet another illustrated embodiment.

FIG. 4D is a top plan view according to yet another illustrated embodiment.

FIG. 4E is a top plan view according to yet another illustrated embodiment.

FIG. 4F is a top plan view according to yet another illustrated embodiment.

FIG. 4G is a top plan view according to yet another illustrated embodiment.

FIG. 4H is a top plan view according to yet another illustrated embodiment.

FIG. 5 is a diagram showing how common leads can be shared by elements used for flow sensing.

FIG. 6A is a schematic diagram showing an example of techniques used to improve precision in measuring voltage drops across elements.

FIG. 6B is a schematic diagram showing an example of techniques used to improve precision in measuring voltage drops across elements.

FIG. 6C is a schematic diagram showing an example of techniques used to improve precision in measuring voltage drops across elements.

FIG. 7 is a circuit diagram of an example of a system used for flow sensing, port location, and tissue ablation.

FIG. 8 is a circuit diagram of a second example of a system used for flow sensing, port location, and tissue ablation.

FIG. 9 is a circuit diagram of a third example of a system used for flow sensing, port location, and tissue ablation.

FIG. 10A is a top plan view of a structure having distinct permittivity sensor elements, temperature sensor elements and ablation elements, according to one illustrated embodiment.

FIG. 10B is a top plan view of a structure having integrated permittivity sensor and ablation elements, according to one illustrated embodiment.

FIG. 10C is a top plan view of a structure having integrated permittivity sensor and ablation elements, according to another illustrated embodiment.

FIG. 10D is a top plan view of a structure having integrated permittivity and temperature sensor and ablation elements, according to one illustrated embodiment.

FIG. 11 is a circuit diagram of an example of a system used for permittivity sensing, port location, and tissue ablation.

FIG. 12A is a top plan view of a structure having distinct force sensor elements, temperature sensor elements and ablation elements, according to one illustrated embodiment.

FIG. 12B is top plan view of a structure having force sensor elements that are distinct from integrated temperature sensor and ablation elements, according to one illustrated embodiment.

FIG. 12C is a top plan view of a leaf shaped structure having force sensor elements that are distinct from integrated temperature sensor and ablation elements, according to one illustrated embodiment.

FIG. 13 is a circuit diagram of an example of a system used for force sensing, port location, and tissue ablation.

FIG. 14A is an example of a frame using multiple helix shaped members.

FIG. 14B is an example of a frame using multiple helix shaped members.

FIG. 15A is an example of a frame using a single helix shaped member and multiple ribs.

FIG. 15B is an example of a frame using a single helix shaped member and multiple ribs

FIG. 15C is an example of a frame using a single helix shaped member and multiple ribs.

FIG. 16A is an example of an inflatable frame with ports for blood flow.

FIG. 16B is an example of an inflatable frame with ports for blood flow.

FIG. 17A is a top plan view of a joint assembly structure, according to one illustrated embodiment.

FIG. 17B is a top plan view of a joint assembly structure, according to another illustrated embodiment.

FIG. 17C is a top plan view of a joint assembly structure, according to another illustrated embodiment.

FIG. 17D is a top plan view of a joint assembly structure, according to another illustrated embodiment.

FIG. 17E is a top plan view of a joint assembly structure, according to another illustrated embodiment.

FIG. 18A is a top plan view of a joint assembly structure, according to another illustrated embodiment.

FIG. 18B is a top plan view of a joint assembly structure, according to another illustrated embodiment.

DETAILED DESCRIPTION OF THE INVENTION

In the following description, certain specific details are set forth in order to provide a thorough understanding of various embodiments of the invention. However, one skilled in the art will understand that the invention may be practiced without these details. In other instances, well-known structures associated with RF ablation and electronic controls such as multiplexers have not been shown or described in detail to avoid unnecessarily obscuring descriptions of the embodiments of the invention.

Unless the context requires otherwise, throughout the specification and claims which follow, the word “comprise” and variations thereof, such as, “comprises” and “comprising” are to be construed in an open, inclusive sense, that is as “including, but not limited to.”

The word “ablation” should be understood to mean any disruption to certain properties of the tissue. Most commonly the disruption is to the electrical conductivity and is achieved by heating, which could be either resistive or by use of Radio Frequencies (RF). Other properties, such as mechanical, and other means of disruption, such as optical, are included when the term “ablation” is used.

Reference throughout this specification to “one embodiment” or “an embodiment” means that a particular feature, structure or characteristic described in connection with the embodiment is included in at least one embodiment of the present invention. Thus, the appearances of the phrases “in one embodiment” or “in an embodiment” in various places throughout this specification are not necessarily all referring to the same embodiment. Furthermore, the particular features, structures, or characteristics may be combined in any suitable manner in one or more embodiments.

As used in this specification and the appended claims, the singular forms “a,” “an,” and “the” include plural referents unless the content clearly dictates otherwise. It should also be noted that the term “or” is generally employed in its sense including “and/or” unless the content clearly dictates otherwise. The headings provided herein are for convenience only and do not interpret the scope or meaning of the claimed invention.

Overview of Device and Mapping Methods

Various embodiments of percutaneously or intravascularly deployed medical devices are described herein. The medical devices are capable of expanding into a cavity within a body and sensing characteristics (e.g., convective cooling, permittivity, force) that distinguish between blood and non-blood tissue. Such sensed characteristic allow a medical system to map the cavity, for example using positions of openings or ports into and out of the cavity to determine a position and/or orientation (i.e., pose) of the medical device in the cavity. The medical devices may also be capable of ablating tissue in a desired pattern within the cavity. The medical devices may further be capable of sensing characteristics (e.g., electrical activity), indicative of whether ablation has been successful.

An example of the mapping performed by the medical treatment devices would be to locate the position of the four openings leading to the pulmonary veins as well as the mitral

valve on the interior surface of the left atrium. The mapping is based on locating such openings by differentiating between blood and non-blood tissue. There are many ways to differentiate non-blood tissue from a liquid such as blood or to differentiate non-blood tissue from an opening in case a liquid is not present. By the way of example, three approaches will be detailed in the disclosure:

1. One approach to determining the locations is to use the convective cooling of heated transducer elements by the blood. A slightly heated mesh of transducer elements positioned adjacent to the non-blood tissue that forms walls of the atrium and across the openings or ports of the atrium will be cooler at the areas which are spanning the openings or ports carrying blood flow.

2. Another approach to determining the locations is to make use of the differing change in dielectric constant as a function of frequency between blood and non-blood tissue. A set of transducer elements positioned around the non-blood tissue that forms the interior surface of the atrium and across the openings or ports of the atrium monitor the ratio of the dielectric constant from 1 KHz to 100 KHz. Such can be used to determine which of those transducer elements are not proximate to non-blood tissue, which is indicative of the locations of openings or ports.

3. Yet another approach to determining the locations is to sense a position of the non-blood tissue that forms the atrium walls using transducer elements that sense force (i.e., force sensors). A set of force detection transducer elements positioned around the non-blood tissue that forms the interior surface of the atrium and across the openings or ports of the atrium can be used to determine which of the transducer elements are not in contact with the non-blood tissue, which is indicative of the locations of openings or ports.

FIG. 1 shows a medical device 100 useful in diagnosing and/or treating a bodily organ, for example a heart 102, according to one illustrated embodiment.

The medical device 100 may be percutaneously and/or intravascularly inserted into a portion of the heart 102, for example in a left atrium 104 of the heart 102. In this example, the medical device is delivered via a catheter 106 inserted via the superior vena cava 108 and penetrating the transatrial septum 110 from a right atrium 112.

The catheter 106 may include one or more lumens 114. The lumen(s) 114 may carry one or more communications and/or power paths, for example one or more wires 116. The wires 116 provide connections to the medical device 100 that are accessible externally from a patient in which the medical device 100 is inserted.

As discussed in more detail herein, the medical device 100 comprises a frame 118 which expands (shown in expanded configuration in FIG. 1) upon delivery to the left atrium 104 to position a plurality of transducer elements 120 (only three called out in FIG. 1) proximate the interior surface or non-blood tissue 122 of the left atrium 104. At least some of the transducer elements 120 of the medical device are used to sense a physical characteristic of blood and/or tissue that may be used to determine a position and/or orientation or pose of the medical device 100 in the left atrium 104. For example, the transducer elements 120 may be used to determine a location of pulmonary vein ostiums 124 and/or a mitral valve 126. At least some of the transducer elements 120 of the medical device 100 may be used to selectively ablate non-blood tissue, for example portions of the interior surface 122 of the left atrium 104. For example, some of the elements may be used to ablate a

pattern around the openings, ports or pulmonary vein ostiums **124**, for instance to reduce or eliminate the occurrence of atrial fibrillation.

FIG. 2 shows a medical device **200** according to one illustrated embodiment.

The medical device **200** takes the form of an expandable electrode grid or array **202**, including a plurality of flexible strips **204** (three called out in FIG. 2). A plurality of transducer elements **206** (four called out in FIG. 2) form a two- or three-dimensional grid or array capable of mapping the inside surface of a cavity or lumen without requiring mechanical scanning. An expandable frame **208** may be used to force flexible strips **204** against the inside walls of the cavity. The expandable frame **208** may include one or more resilient members. For example, the expandable frame **208** may consist of or include a shape memory material, for instance Nitinol. Such may be useful for both accurate location of the parts, position and/or orientation (i.e., pose) and/or for successful ablation of a desired pattern.

The expandable frame **208**, as well as flexible strips **204** can be delivered and retrieved via a catheter member, for example a catheter sheath introducer **210**, which in some embodiments may have a diameter of about 8 mm or smaller. Flexible strips **204** may be made of one or more thin layers of Kapton (polyimide), for instance 0.1 mm thick. Transducer elements (e.g., electrodes and/or sensors) **206** may be built on the flexible strips **204** using standard printed circuit board processes. An overlay of a thin electrical insulation layer (e.g., Kapton about 10-20 microns thick) may be used to provide electrical insulation, except in areas needing electrical contact to blood and non-blood tissue. In some embodiments, the flexible strips **204** can form an elongated cable **216** of control leads **218**, for example by stacking multiple layers, and terminating in a connector **220**. The electrode grid or array **202** is typically disposable.

The medical device **200** may communicate with, receive power from and/or be controlled by a control system **222**. The control system **222** may include a computing system **224** having one or more processors **226** and one or more memories **228** that store instructions that are executable by the processors **226** to process information received from the medical device **200** and/or to control operation of the medical device **200**, for example activating selected transducer elements **206** to ablate non-blood tissue. The control system **222** may include an ablation source **230**. The ablation source **230** may, for example, provide electrical power, light or low temperature fluid to the selected transducer elements to cause ablation. The control system **222** may also include one or more user interface or input/output (I/O) devices, for example one or more displays **232**, speakers **234**, keyboards, mice, joysticks, track pads, touch screens or other transducers to transfer information to and from a user, for example a care provider such as a medical doctor or technician. For example output from the mapping process may be displayed on a display **232**.

While the disclosed systems are described with examples of cardiac mapping, the same or similar systems may be used for mapping other bodily organs, for example gastric mapping, bladder mapping, arterial mapping and mapping of any lumen or cavity into which the medical device **204** may be introduced.

The term "transducer element" in this disclosure should be interpreted broadly as any component capable of distinguishing between blood and tissue, sensing temperature, creating heat, ablating tissue and measuring electrical activity of a non-blood tissue surface, or any combination

thereof. A transducer element may be constructed from several parts, which may be discrete components or may be integrally formed.

Sensing Convective Cooling

FIG. 3 shows a portion of a medical device **300**, according to one illustrated embodiment.

The portion of the medical device **300** is particularly suitable to sense convective cooling. The medical device **300** includes miniature transducer elements **302a**, **302b**, **302c** (collectively **302**) capable of producing heat. The transducer elements **302** may, for example, be made of insulated resistive wire, such as Nickel, or Nickel-iron composition. The resistive wire may be mounted on an expandable frame **304**. In this embodiment, the expandable frame **304** may also be made of a material that has high impedance. Current passed through each transducer element **302** raises the temperature of the transducer element **302** by a nominal amount. A rise of 0.5-3.0 degrees Celsius above normal blood temperature has been found to be sufficient in most cases. The power required to raise the temperature in this particular embodiment is about 10-50 mW per transducer element **302**. A central one of the transducer elements **302b**, which is placed across the opening, port of ostium **306** of the pulmonary vein **308** will be cooled by blood flow more than the neighboring transducer elements **302a**, **302c** which are adjacent to the inner or interior surface or non-blood tissue **310** that forms the wall of the heart. Transducer elements **302** which are found to be cooler on expandable frame **304** indicate the locations of openings or ports **306** in the non-blood tissue **310** that forms the wall of the heart. This embodiment does not require intimate contact with the bodily tissue **310** of the heart wall, as even a few millimetres from the openings or ports **306** the cooling effect is significant compared to the cooling effect a few millimetres from the non-blood tissue **310** of the heart wall. The back side of the transducer elements **302** may be thermally insulated for improved performance of both sensing and ablation. Using a flat ribbon for the expandable frame **304** may be advantageous. A cross section of a ribbon expandable frame **304** may, for example have dimensions of 0.2x2 mm for stainless steel or 0.3x2.5 mm for Nitinol. The insulation on the back side of the transducer elements **302** may take the form of a coat of silicone rubber.

If the transducer elements **302** are made of a material that has a significant change in resistance with temperature, the temperature drop can be determined from the resistance of the transducer element **302**. The resistance can be determined by measuring the voltage across the transducer element **302** for a given current, or alternatively by measuring the current across the transducer element **302** for a given voltage, for example via a Wheatstone bridge circuit. Thus, some embodiments may take advantage of convective cooling by the flow of blood, at least some of the transducer elements **302** functioning as a hot wire anemometer. Nickel wire is a suitable material to use, as nickel is inert, highly resistive and has a significant temperature coefficient of resistance (about 0.6% per deg C.). Since the resistance of the transducer elements **302** is low (typically less than 5 ohm), the electrical noise is very low and temperature changes as low as 0.1-1 deg can be detected. There are several techniques to improve on this sensitivity. One method is to sample the voltage waveform in synchronization with the heart rate. Another is to remove the average voltage via AC coupling and only amplify the voltage change or derivative. Yet another method to reduce the electrical noise is to pass the signal through a digital band pass filter having a center frequency tracking the heart rate.

FIGS. 4A-4G show examples of alternative ways of constructing transducer elements. Each of the embodiments of FIGS. 4A-4F show transducer elements which have been constructed using printed circuit board (PCB) substrates. These transducer elements may be affixed to a structure similar to the expandable frame 208 shown in FIG. 2, which may be made from a material such as Nitinol. Alternatively, the PCB substrates may be of such a thickness that the PCB substrates can form the expandable frame. The PCB substrates should be flexible enough to conform to the non-blood tissue, but stiff enough such that the PCB substrate does not buckle. PCB substrates may, for example, be made from Kapton®. A PCB substrate made of Kapton® having a thickness, for instance, of approximately 0.1 to 0.3 mm may be suitable. The transducer elements could also be constructed using discrete components. FIGS. 4G-4H show embodiments that do not employ PCB substrates.

FIG. 4A shows a PCB substrate 400a that carries a combination of transducer elements, in particular sensor transducer elements 402a, 402b (collectively 402, only two called out in FIG. 4A) which sense convective cooling and ablation transducer elements 404a, 404b (collectively 404, only two called out in FIG. 4A) which are operable to ablate non-blood tissue. Leads, collectively 406, extend to respective ones of the transducer elements 402, 404. The leads 406 may be coupled to a control system (e.g., control system 222 of FIG. 2), which may provide communications, power and/or control with the transducer elements 402, 404.

FIG. 4B shows a PCB substrate 400b that carries a number of combined sensor and ablation transducer elements 408a, 408b (collectively 408, only two called out in FIG. 4B) that both sense flow and ablate non-blood tissue. Such a feature may be a significant advantage since a medical device with combined sensor and ablation transducer elements 408 can measure flow at the exact spot that ablation will occur, while requiring fewer parts, thus improving precision and reducing size. In this embodiment, each combined sensor and ablation transducer element 408 has respective leads, collectively 410, coupled to a control system (e.g., control system 222 of FIG. 2).

A combined sensor and ablation transducer element 408 that can be used for both sensing flow and ablating can be made using standard PCB construction processes. For example, a 2-4 mil copper trace on a Kapton® substrate can be used. Copper changes resistance sufficiently with temperature to be used to determine blood flow in the manner discussed above. Copper can also be used as an ablation element by applying sufficient current through the copper to cause the combined sensor and ablation transducer element 408 to heat resistively, for example to a temperature above 60° C. Power in the range of approximately 130-250 mW delivered to a copper pattern that has external dimensions of 3 mm×10 mm and is thermally insulated on the side away from the non-blood tissue may be sufficient to transmurally ablate a 3 mm deep section of the non-blood tissue that forms the atrium wall. In this approach, the non-blood tissue is heated by conduction from the copper combined sensor and ablation transducer element 408. When heating the non-blood tissue by conduction, the combined sensor and ablation transducer element 408 may be electrically insulated from the non-blood tissue.

Alternatively, the combined sensor and ablation transducer element 408 can also be used to ablate non-blood tissue by using the combined sensor and ablation transducer element 408 as an electrode for delivering RF energy to the non-blood tissue. In this scenario, electrical current is transferred directly to the non-blood tissue and the non-blood

tissue is resistively heated by the current flow. When delivering RF energy, a preferred method may be to have low electrical impedance between the combined sensor and ablation transducer element 408 and the non-blood tissue.

Delivering RF energy is also possible if the combined sensor and ablation transducer element 408 is capacitively coupled to the non-blood tissue, so long as the impedance at the frequency of RF energy being used is sufficiently low—typically under a few kilo ohms or less for a combined sensor and ablation transducer element of the size mentioned above. Note that in the case where the combined sensor and ablation transducer element 408 has a low electrical impedance connection to the non-blood tissue for low frequencies, it is also possible to use the combined sensor and ablation transducer element 408 to sense an electrical potential in the non-blood tissue that forms the heart wall, for example to generate an electro-cardiogram. Thus it is possible for the same combined sensor and ablation transducer element 408 to sense flow, sense electrical potential of the non-blood tissue that forms the heart wall, and ablate non-blood tissue.

FIG. 4C shows a PCB substrate 400c that carries a number of combined flow sensor, ablation and temperature transducer elements 412a, 412b (collectively 412, only two called out in FIG. 4C) that can be used to sense flow, ablate non-blood tissue and sense or monitor temperature, for example for ablation control. A single control lead, collectively 414, is required per combined flow sensor, ablation and temperature transducer element 412, plus a common return lead 416 to the multiple combined flow sensor, ablation and temperature transducer elements 412. The combined flow sensor, ablation and temperature transducer element 412 can take the form of a low resistance resistor, for example a resistor formed by a 30-100 micron wide trace of 10-30 micron copper foil. Such a resistor has a typical resistance of 2-20 ohms and can be used as a combined flow sensor, ablation and temperature transducer element 412 to sense flow, perform ablation and sense temperature. When used as a temperature sensor, the resistance changes about 1% for a 2 degree C. temperature change.

FIG. 4D shows a PCB substrate 400d that carries a number of adjacent transducer elements 420a, 420b (collectively 420, only two called out in FIG. 4D). The transducer elements 420 share common control leads 422. This feature is an advantage as it dramatically reduces the number of leads 422 needed to return to the control system (e.g., control system 222 of FIG. 2).

FIG. 5 shows an expanded example of a portion of the embodiment of FIG. 4D positioned proximate non-blood tissue 500. To determine flow by measuring the resistance of transducer element 420b, the voltage at a lead 422a and lead 422b should be made equal and the voltage at a lead 422c and lead 422d should be made equal, but to a different voltage than that of lead 422a and lead 422b. In this condition, negligible current will flow through transducer element 420a and transducer element 420c. Therefore, the current flowing through lead 422b and lead 422c is the same as the current flowing through the transducer element 420b, and the resistance of the transducer element 420b can be calculated in a straightforward manner using the equation $V=I/R$.

To cause the transducer element 420b to heat to a temperature sufficient to cause ablation, while not causing ablation at transducer element 420a and transducer element 420c:

the voltage at lead 422c and lead 422d should be made equal;

the voltage at lead **422b** should be made higher than the voltage at lead **422c** such that sufficient power is delivered to the transducer element **420b** to cause the transducer element **420b** to heat to the appropriate temperature; and

the voltage at lead **422a** should be set a value that is a fraction of that at lead **422b** such that the power delivered to the transducer element **420a** is not sufficient to cause the temperature of the transducer element **420a** to rise enough for tissue ablation.

For example, if the voltages at lead **422c** and lead **422d** are set to 0 v, voltage at lead **422b** is set to n volts and voltage at lead **422a** is set to $\frac{2}{3}$ n volts, the power delivered to the transducer element **420a** will be only 11% of that delivered to the transducer element **420b**. This technique of having adjacent transducer elements **420** share common leads **422** can, for example, be used in a elongated one-dimensional line of connected transducer elements **420** or may be applied to transducer elements **420** connected in two-dimensional (as illustrated in FIGS. **8**, **17A-17C**, **18A** and **18B**) or three-dimensional arrays.

FIG. **4E** shows a PCB substrate **400e** that carries a number of transducer elements **424a**, **424b** (collectively **424**, only two called out in FIG. **4E**). The transducer elements **424** are coupled to leads **426**, similar to leads **422** of the embodiment of FIG. **4D**, and to additional leads **428**, which have been added to measure the voltage at the ends of the transducer elements **424**. This feature advantageously increases the accuracy in determining the resistance, and thus temperature, of the transducer elements **424**. The leads **426** that provide the current to the transducer elements **424** typically have a small voltage drop across them that can affect the accuracy of the resistance calculation of the transducer element **424**. These additional leads **428** will have a very limited amount of current flowing through them, and thus the voltage drop through the leads **428**, even for a distance of several meters will be negligible, and the voltage drop across the transducer elements **424** can be determined accurately.

FIG. **4F** shows a flexible PCB substrate **400f** that forms a leaf shaped assembly. An expandable frame (e.g., expandable frame **208** of FIG. **2**) may be covered by several of these leaf shaped assemblies, each of which will cover or be proximate a respective portion of the non-blood tissue that forms the wall of the body organ when in use. Each of the leaf shaped assemblies carries a plurality of transducer elements **430a**, **430b** (collectively **430**, only two called out in FIG. **4F**). In this example, the transducer elements **430** are coupled together as described above embodiment of FIG. **4D**. Leads **432** couple each transducer **430** to a control system (e.g., control system **222** of FIG. **2**). The leads **432** may couple power, communications and/or control signals. The leads **432** may, for example, provide for electrically conductive coupling, inductive coupling, capacitive coupling, optical coupling, galvanic coupling, fluidic coupling and/or thermal coupling.

There are other approaches for creating the transducer elements that do not rely on a PCB. FIGS. **4G** and **4H** provide examples of some of these.

FIG. **4G** shows transducer elements **440a**, **440b** (collectively **440**, only two called out in FIG. **4G**) that are made from a bundle of carbon fibers. Leads **442** couple the transducer elements **440** to a control system.

FIG. **4H** shows transducer elements **450a**, **450b** (collectively **450**, only two called out in FIG. **4H**) that are made directly from a hollow tube of a metal such as stainless steel

or alternatively from wire. Leads **452** couple the transducer elements **450** to a control system.

The structures of the embodiments of FIGS. **4G** and **4H** may be advantageous over other embodiments, since the structures are simple to assemble, and can be used directly as the supporting structure itself. Leads **442**, **452** are connected at intervals to the carbon fibre or metal. The material between the leads **442**, **452** form the transducer elements **440**, **450**. In order to function properly, these transducer elements **440**, **450** should have the electrical properties the same as or similar to the electrical properties indicated previously. These two embodiments provide an example of where the same transducer element **440**, **450** can sense flow, sense or measure temperature, deliver the ablation energy, and/or be an integral component of the supporting structure.

FIGS. **4A-4H** show examples of many transducer element configurations that are possible. From the previous descriptions, it is important to note that a single transducer element can sense blood flow in order to distinguish between blood and non-blood tissue, sense an electrical potential of the non-blood tissue (e.g., heart wall), ablate non-blood tissue, sense or measure temperature, and/or form an integral component of the supporting structure, or any combination of these functions. The ablation may be performed by causing the transducer element to heat, or by delivering energy, such as RF directly to the non-blood tissue. Also, transducer elements can be constructed using individual leads, common ground lead, or shared leads. Each lead may have a separate lead that runs in parallel to it for the purpose of accurately determining voltage potential directly at the transducer element. As well, the examples discussed methods of sensing temperature that relied on changes in resistance. However, it is certainly possible to use other temperature sensing methods, such as thermistors or thermocouples in conjunction with the transducer elements that produce heat. For example, the sensing transducer element of the embodiment of FIG. **4A** could be a thermistor, thermocouple or temperature sensitive diode.

FIG. **7** shows an embodiment of an electric circuit **700** that can be used to distinguish between blood and non-blood tissue by sensing flow of blood.

In this example, transducer elements **702a-702d** (collectively **702**) may be resistive elements, for example formed from copper traces on a flexible printed circuit board substrate, or resistive wires mounted on a structure. Each transducer element **702** is connected by electronic transducer selection switches **704a-704h** (collectively **704**) to a single pair of wires **706a**, **706b** (collectively **706**) that provide a path out of the body via a cable **708**. The transducer selection switches **704** may, for example be FET or MOSFET type transistors. The transducer selection switches **704** will typically need to carry significant power during the ablation phase. The cable **708** may extend through a lumen of a catheter or may otherwise form part of a catheter structure.

The transducer selection switches **704** are selected by signals applied by a demultiplexer (selector) **710**. The demultiplexer **710** may be controlled by a small number of wires **712** (or even a single wire if data is relayed in serial form). The wires **706**, **712** extend out of the body via the cable **708**. The transducer selection switches **704** and the demultiplexer **710** may be built into a catheter (e.g., catheter **106** of FIG. **1**) near a distal end or point of deployment. The transducer selection switches **704** and demultiplexer **710** may be located within or near the expandable frame (e.g.,

expandable frame **208** of FIG. 2) in order to minimize the number and/or length of connecting wires extending through the catheter.

At the other or proximate end of the catheter are a mode selection switch **726** and multiplexer **714**. The mode selection switch **726** is operable to select between a flow sensing mode (position shown in the drawing) and an ablation mode (second position of the mode selection switch **726**). In flow sensing mode, a current is created by a voltage source **716** and resistor **718** (forming an approximate current source) and routed into a transducer element **702** selected via transducer selection switches **704**. The two transducer selection switches **704** that are connected to a given one of the transducer elements **702** to be used to sense flow, are set to be closed and the remainder of the transducer selection switches **704** are set to be open. The voltage drop across the transducer element **702** is measured via an Analog-to-Digital converter (ADC) **720** and fed to the control computer **722**.

It may be advantageous to use alternating current or a combination of alternating current and direct current for sensing and ablation. For example, direct current for ablation and alternating current for sensing. Alternating current approaches may also prevent errors from electrochemical potentials which could be significant if different metals come in touch with blood.

Determination of the location of the openings or ports into the chamber may be achieved by turning on all of transducer elements **702** sequentially or in groups and determining a temperature by measuring the resistance of each transducer element **702**. A map of the temperature of the transducer elements **702** may be formed in control computer **722** or the control computer **722** may otherwise determine a position and/or orientation or pose of the device in the cavity. The transducer elements **702** with lower temperatures correspond to the openings or ports leading to the veins or valves.

When mode selection switch **726** is set to select ablation, an ablation power source **724** is connected sequentially to the transducer elements **702** that are selected by the control computer **722** by addressing the multiplexer **714**, which in turn controls the transducer selection switches **704** via the demultiplexer **710**. The ablation power source **724** may be an RF generator, or it may be one of several other power sources, several of which are described below. If ablation power source **710** is an RF generator, the configuration of FIG. 7 implies unipolar RF ablation, in which current is fed into the non-blood tissue and passes to a ground connected to the body. The current that passes through the non-blood tissue causes the non-blood tissue to heat. However, bipolar ablation can be used as well. Other sources of ablation can be used besides radio frequency. Frequencies from DC to microwaves can be used, as well as delivery of laser power via optical fibers or cryogenics via thin tubes. For laser ablation, the transducer selection switches **704** may take the form of optical switches. For cryogenic ablation, the transducer selection switches **704** take the form of suitable valves and/or actuators (e.g., solenoids). Alternatively, the bottom terminal of the lower switch of mode selection switch **726** may be coupled directly to ground. In this configuration, the ablation power source **724** can be configured to supply current with frequencies from DC to microwave, which will cause the selected transducer elements **702** to heat directly and produce ablation via thermal conduction.

During ablation it may be desirable to monitor the temperature of the non-blood tissue. The ideal temperature range for the non-blood tissue during ablation is typically 50-100 C°. Since the example includes temperature monitoring as part of the blood flow sensing, the progress of

ablation can be monitored by temporarily switching mode selection switch **726** to a temperature sensing position several times during the ablation.

FIG. 8 shows another embodiment of a circuit **800** that can be used to distinguish between blood and non-blood tissue by sensing flow.

In this example, transducer elements **802a-802g** (collectively **802**, only seven called out in FIG. 8) may be resistive elements, for example formed from copper traces on a printed circuit board substrate, or resistive wires mounted on a structure. The ends of each transducer element **802** are electrically coupled to the ends of adjacent transducer elements **802** to form a connected grid or array **804**. Each node (indicated in FIG. 8 by the markings A, B, C, D, E, F, G, H, and I) in the grid or array is electrically coupled to a respective control wire, collectively **806**. The control wires **806** extend out of the human or animal body via a cable **808**, which may, for example extend through a lumen of a catheter.

The control wires **806** may be coupled to respective ones of transducer selection switches **810a-810i** (collectively **810**) at a proximate end of a catheter. Each of the transducer selection switches **810** is controlled by a control system **812**, which may, for example, take the form of a programmed general purpose computer, special purpose computer, applications specific integrated circuit (ASIC) or field programmable gate array (FPGA). The control system **812** applies signals to select between an adjustable current source **814a-814i** (collectively **814**) and ground **816** (only one called out in FIG. 8).

When a given transducer element **802** is to be used for blood flow sensing, the transducer selection switch **810** connected to the node A-I on one end of the given transducer element **802** is set to select the current source **814** and the transducer selection switch **810** connected to the node on the other end of the given transducer element **802** is configured to select ground **816**. All nodes connected by a transducer element **802** to the node configured to select a current source **814** are also configured to select a current source **814**. All nodes connected by a transducer element **802** to the node configured to select a ground are also configured to select ground **816**. All of the connected current sources **814** are adjusted to deliver the same small voltage at the nodes A-I they are connected to. For example, if the transducer element **802e** is to be used, then nodes B, D E, and H will be connected to current sources **814b**, **814d**, **814e**, **814h**, and nodes A, C, F, G, and I will be connected to ground **816**. The connected current sources **814b**, **814e**, **814d**, **814h** will be adjusted so that the voltage at nodes B, E, D, and H will be the same. The control system **812** controls the voltage at the nodes, for example by:

- selecting the desired node with a multiplexer **818**;
- measuring the voltage with an analog to digital converter (ADC) **820**; and
- adjusting the corresponding current source **814** to achieve the desired voltage.

In this configuration, the current through all transducer elements **802** connected to the given transducer element **802e** will be zero. Therefore all current from the current source **814e** connected to the given transducer element **802e** will pass through the transducer element **802e**. As both the voltage drop across and the current through the given transducer element **802e** are known, the resistance can be determined and the corresponding temperature can be determined. Determination of the location of the openings or ports into the cavity (e.g., chamber or atrium) may be achieved by turning on all or at least some of transducer

elements **802** sequentially, and determining the temperature by measuring a resistance of each of the transducer elements **802**. The control system **812**, or some other system, may produce a map of the temperature of the transducer elements **802**, where the lower temperatures correspond to the open- 5 ings or ports leading to veins or valves.

When a transducer element **802** is to be used for ablation, the transducer selection switch **810** connected to the node A-I on one end of the given transducer element **802** is set to select the current source **814** and the transducer selection switch **810** connected to the node A-I on the other end of the given transducer element **802** is configured to select a ground connection **816**. All nodes A-I connected by a transducer element **802** to either end of the given transducer element **802** to be used for ablation are configured to select 15 a current source **814**. The current source **814** connected to the given transducer element **802** to be used for ablation is set to deliver sufficient power to the given transducer element **802** to raise its temperature to 50° C.-100° C., enough to cause non-blood tissue ablation. All of the other connected current sources **814** are adjusted to deliver current so that the voltages at the node A-I they are connected to is a percentage of the voltage at the node A-I connected to the given transducer element **802** being used for ablation. For example, if the transducer element **802e** is to be used for 25 ablation, then nodes B, C, D, E, H, and I will be connected to current sources **814b**, **814c**, **814d**, **814e**, **814h**, **814i**, and node A, F, and G will be connected to ground **816**. The current source **814e** connected to node E will be adjusted so that sufficient power is delivered to transducer element **802e** 30 to cause ablation. In doing so, a voltage will be generated at the node E. The current sources **814b**, **814d**, **814h** connected to nodes B, D, and H are set to ensure the voltage at those nodes is, for example 66% of the voltage at node E. The current sources **814c**, **814i** connected to nodes C and I are set 35 to ensure the voltages at those nodes is, for example 33% the voltage at node E. In doing do, the power delivered to all transducer elements **802** connected to nodes B, C, D, H, and I will be 11% of the power delivered to the given transducer element **802e**, which is insufficient for ablation. It is possible 40 to use different percentages for voltage values than specified herein.

While FIG. **8** shows one current source for each element, it is also possible to create a circuit that uses multiplexing to reduce the number of required current sources. Also, a circuit can be specified that uses voltage sources instead of 45 current sources.

There are several ways to improve the accuracy in sensing the voltage drop across the transducer elements to improve accuracy of temperature measurement or flow sensing. One approach to achieve improved accuracy is to use four 50 terminal sensing.

FIG. **6A** shows a circuit **600a** that implements four terminal sensing, according to one illustrated embodiment.

In FIG. **6A**, a transducer element **602a** is coupled to 55 power leads **604a**, **604b** (collectively **604**) to supply the current necessary to cause the transducer element **602a** to heat sufficiently to be able to measure convective cooling. Measurement leads **606a**, **606b** (collectively **606**) are used to measure the voltage across the transducer element **602a**. Negligible current goes through measurement leads **606a**, **606b** and so there is no voltage drop over the length of the measurement leads **606**. 60

In some configurations, being able to minimize the effect of lead resistance when measuring voltage across the transducer elements is possible without adding additional wires. FIG. **6B** shows a circuit **600b** that may implement such. 65

In temperature sensing or convective cooling sensing mode, leads **610a**, **610b** (collectively **610**) are used to supply and sink the current necessary to cause transducer elements **612a-612e** (collectively **612**) to produce sufficient heat to be able to measure convective cooling. Leads **614a**, **614b** are used to measure the voltage across transducer element **612a**. Leads **614b**, **614c** are used to measure the voltage across transducer element **612b**. Leads **614c**, **614d** are used to measure the voltage across transducer element **612c**. Leads **614d**, **614e** are used to measure the voltage across transducer element **612d**. Leads **614e**, **614f** are used to measure the voltage across transducer element **612e**. During ablation mode, leads **614a**, **614b** are used to supply the current to cause transducer element **612a** to ablate the non-blood tissue, leads **614b**, **614c** are used to supply the current to cause the transducer element **612b** to ablate, and so on.

FIG. **6C** shows a circuit **600c** according to another illustrated embodiment. The circuit **600c** may minimize the effect of lead resistance when measuring voltage across the transducer elements without adding additional wires.

As an example, the transducer element **622a** between nodes J and O is being used for temperature, flow, or convective cooling sensing. The leads connected to nodes J and O supply the current to the transducer element **622a** between the nodes. This causes a measurable voltage drop across the transducer element **622a** between nodes J and O. The leads attached to nodes B, D, E, F, I, K, N, P, S, T, U, W are used to sense voltage at the respective nodes. The control system to which the leads are attached is configured so that there is negligible current flow through these leads, and negligible voltage drop across the leads. The leads attached to nodes A, C, G, H, L, M, Q, R, V, and X are actively driven and drive the nodes to a particular voltage. The control system adjusts the voltages at nodes A, C, G, H, and L so that the voltage measured at nodes B, D, E, F, I, and K are all measured to be equal. When this state occurs, the current between nodes E and D, E and B, E and F is negligible and therefore, the current between nodes E and J must be negligible, and node E will be at the same potential as node J. The control system adjusts the voltages at nodes X, R, V, M, and Q so that the voltage measured at nodes W, S, T, U, N, and P are all measured to be equal. When this state occurs, the current between nodes S and T, T and W, T and U is negligible and therefore, the current between nodes T and O must be negligible, and node T will be at the same potential as node O. The voltage drop across the element between nodes J and O is therefore equal to the difference between the voltage at node E and the voltage at node T.

FIG. **9** shows an embodiment that reduces the number of control leads.

FIG. **9** shows a circuit **900** that includes a plurality of transducer elements **902a-902i** (collectively **902**, only nine called out in FIG. **9**) which may form a one-, two-, or three-dimensional grid or array **904**. A plurality of diodes **906a-906i** (collectively **906**, only nine called out in FIG. **9**) or other non-linear devices or active devices are used to reduce the number of control leads **908**. The leads **908** may be externally accessible from an exterior of a patient, for example via a cable **910** that extends through a lumen of a catheter or otherwise forms part of a catheter.

When this circuit **900** is not sensing or ablating, adjustable voltage sources **914a-914h** (collectively **914**, only eight called out in FIG. **9**) are configured to reverse bias the diodes **906**, so no current flows in the circuit **900**. The circuit **900** may include a plurality of current sensors **912a-912h** (collectively **912**), which couple signals indicative of sensed currents to a control system **916**. In this example, the reverse

biasing operation is achieved by setting voltage sources **914a-914d** to positive voltage “h” and voltage sources **914e-914h** to ground. When a transducer element **902** is to be used for flow sensing, temperature sensing, or ablation, the diode **906** that is in series with the given transducer element **902** is forward biased. This is achieved by setting the voltage source **914** that is connected to the given diode **906** to a positive voltage “g” that is greater than 0 and less than h, and setting the voltage source **914** that is connected to the given transducer element **902** to a positive voltage “f” which is greater than 0 and less than g and sufficient to forward bias the respective diode **906**. For example, if the transducer element **902e** is to be used for sensing or ablation, adjustable voltage source **914g** should be set to g volts, adjustable voltage source **914b** should be set to f volts, adjustable voltage sources **914a, 914c, 914d** should be set to h volts, and adjustable voltage sources **914e, 914f, and 914h** should be set to ground where $0 < f < g < h$. The particular values used for f, g, and h depend on such factors as the desired amount of heat from the transducer element **902** and the resistance of the transducer element **902**. Since the forward voltage of a silicon diode changes about 2 mV/degC, the diodes **906** can also be used as temperature sensors.

In some embodiments, it is beneficial to ensure the entire medical treatment device is electrically insulated from the body. The reasons that this may be desirable are to prevent electrochemical activity from generating offset voltages, prevent leakage currents from affecting measurements and prevent gas bubble generation inside the blood stream.

Sensing Impedance Change

Measuring electrical impedance has been suggested as a way for determining when a catheter probe is in contact with the non-blood tissue of the heart wall. However, distinguishing non-blood tissue from blood using electrical impedance is problematic as the impedance is affected by many factors such as contact pressure and contact area. Also, the transducer element (e.g., electrode) may be in contact with many different materials, each of which has different impedance. However, using permittivity (also known as dielectric constant) measured over a range of frequencies can be used effectively to make the determination between blood and non-blood tissue.

As mentioned, material such as blood, muscle tissue, fat, fibrous material, and calcified tissue each has different impedance. However, in all the materials mentioned, except for blood (and other liquids such as urine) the permittivity drops with increasing frequency. For example, the conductivity of all those materials, including blood, stays nearly constant from DC to over 100 MHz. The permittivity of blood (and most other liquids in the body) is about the same at 1 KHz and 100 KHz, while in all other materials mentioned the dielectric constant drops by about a factor of 4, and typically by at least a factor of 10 between those two frequencies. Therefore, accurate discrimination between blood and non-blood tissue can be made by monitoring the ratio of the permittivity at 1 KHz to the value at 100 KHz. Table 1 and Table 2 show the change of Conductivity and Relative Permittivity with respect to frequency.

TABLE 1

Tissue Conductivity					
$\log_{10}(\text{Freq})$	Conductivity (S/m)				
	3	5	6	7	8
Blood	0.7	0.7	0.7	1	1.49
Fat	0.025	0.025	0.03	0.04	0.06
Muscle	0.4	0.4	0.4	0.4	0.75
Fibrous Material	0.24	0.24	0.24	0.29	0.33
Calcium	0.08	0.08	0.1	0.12	0.17
Vessel Wall	0.58	0.58	0.58	0.67	0.83

TABLE 2

Tissue Relative Permittivity					
$\log_{10}(\text{Freq})$	Relative Permittivity				
	3	5	6	7	8
Blood	4100	4000	2000	300	75
Fat	20000	100	50	30	12
Muscle	400000	10000	8000	200	70
Fibrous Material	2000	500	50	5	3
Calcium	10500	500	250	70	30
Vessel Wall	100000	5000	4000	100	30

FIGS. **10A-10D** show examples of different ways that transducer elements to sense permittivity may be constructed. FIGS. **10A-10D** show examples of various transducer elements which may be constructed using flexible printed circuit board substrates and/or materials. The resulting transducer elements may be affixed to a structure similar to the expandable frame **208** (FIG. **2**) made from a material such as Nitinol. Alternatively, the resulting transducer elements may include PCB substrates of such a thickness that the PCB substrates may form the frame itself. The transducer elements could also be constructed using discrete components.

FIG. **10A** shows a flexible PCB substrate **1000a** that carries permittivity sensor elements **1002** (only one called out in FIG. **10A**) responsive to permittivity, ablation elements **1004** (only one called out in FIG. **10A**) operable to ablate, and temperature sensor elements **1006** (only one called out in FIG. **10A**) responsive to temperature. In the illustrated embodiment, the ablation elements **1004** and temperature sensor elements **1006** share some control leads **1008**. Leads **1008** are coupled to a control system (not illustrated in FIG. **10B**). It is also possible that each ablation elements **1004** and temperature sensor elements **1006** has separate control leads **1008** coupled to a control system (not illustrated in FIG. **10B**).

FIG. **10B** shows a flexible PCB substrate **1000b** that carries combined permittivity sensor and ablation elements **1010** (only one called out in FIG. **10B**) that both responsive to permittivity and are operable to ablate tissue. The PCB substrate **1000b** also carries separate temperature sensor elements **1012** (only one called out in FIG. **10B**) that are responsive to temperature. Leads **1114** are coupled to a control system (not illustrated in FIG. **10B**).

FIG. **10C** shows a flexible PCB substrate **1000c** that carries combined permittivity and ablate elements **1016** (only one called out in FIG. **10C**) that both are responsive to permittivity and are operable to ablate non-blood tissue. Each of the combined permittivity and ablate elements **1016** has a respective lead, collectively **1018**, extending to a control system (not shown in FIG. **10C**). An example of a

circuit used to control and activate the combined permittivity and ablate elements **1016** is shown in FIG. **11**.

FIG. **10D** shows a flexible PCB substrate **1000d** that carries combined permittivity sensor, temperature sensor and ablation elements **1020** that are responsive to permittivity, responsive to temperature and operable to ablate non-blood tissue. Each of the combined elements is coupled by a respective lead, collectively **1022**, to a control system (not illustrated in FIG. **10D**). Such an embodiment can be built using a printed circuit board with copper traces that do not have a surface insulation. The temperature sensing and ablation can be controlled as previously described in reference to FIG. **7**. The permittivity sensing can be controlled as will be described with reference to FIG. **11**.

FIG. **11** shows a circuit **1100** that can be used to distinguish blood from non-blood tissue by detecting the change in permittivity, according to one illustrated embodiment.

A transducer element **1102** carried on a PCB substrate **1104** is in physical contact with a bodily material **1106** (non-blood tissue or blood). The bodily material **1106** is electrically grounded to a same return path **1108** as the circuit **1100**. Instead of a return path, a ground electrode adjacent to the transducer element (e.g., electrode) **1102** can be used. An alternate embodiment may be to use a balanced pair of electrodes with equal but opposite phase signals relative to ground. Such a configuration increases immunity to electrical noise. When frequency F_1 or F_2 is fed to transducer element **1102** from oscillators **1110a**, **1110b** via a resistor **1112** the phase shift of the signal caused by the dielectric constant of the bodily material **1106** can be measured by a phase meter. The permittivity is the tangent of the phase shift. For better noise immunity both the in-phase component and the out-of-phase, or quadrature, are measured (outputs **1114a**, **1114b**) then divided to determine the phase shift. The in-phase and out-of phase components are measured by multiplying the voltage signal on transducer element **1102** with the driving signal and with the driving signal phase shifted by 90 degrees using phase shifter **1116** and multipliers **1118**. A selector **1119** may be used to selectively switch between coupling the frequencies F_1 , F_2 , or no frequency.

A pair of analog-to-digital converters (ADC) **1120** are used to digitize the results, after low pass filtering by capacitor **1122**. If desired, the complete operation can be performed digitally by digitizing the signal from the transducer element **1102**, since the highest frequency is relatively low. A separate circuit can be used for each transducer element **1102** or a selector **1124** (also known as multiplexer or analog switch) can connect the same circuit to multiple transducer elements **1102** in rapid succession. The time needed for an accurate measurement is typically several milliseconds; therefore even a large grid or array of transducer elements **1102** can be mapped quickly. A same lead **1126** can also be used to feed current for RF ablation using ablation energy source **1128** and a switch **1130**. Alternatively a different power source, such as a DC current source, could be connected and provide a voltage and current for directly causing the transducer element **1102** to produce a sufficient amount of heat to cause ablation.

Sensing Force

Another method of distinguishing between non-blood tissue and blood is to measure a force being exerted inwardly on one or more transducer elements mounted or otherwise carried by an expandable frame (e.g., expandable frame **208** of FIG. **2**). As an example of this approach, the transducer elements may take the form of an array of force sensors, for example force sensing pads. A polymeric piezoelectric mate-

rial, such as PVDF, may be used as a force sensing element and two or more force sensing elements may be combined to form a force sensing grid. Such force sensing elements are already commercially available, such as Ktech part number MP-25-04-PL (from www.ktech.com). These PVDF based force sensing pads are very thin, flexible, have high output and are easy to integrate into a flexible printed circuit board. Liquids, such as blood, create very little resistive force when the expandable frame forces the force sensor transducer elements outward to the non-blood tissue that forms the interior surface of the cavity being mapped. The force sensor transducer elements located proximate to the openings or ports will be subject to less force than those proximate to the non-blood tissue. The differing force distribution across the force sensor transducer elements enables the location of the openings or ports to be determined.

FIGS. **12A-12C** show examples of different ways the force sensor transducer elements may be constructed using flexible printed circuit board substrates. Force sensor transducer elements may be affixed to a structure similar to previously described expandable frames (e.g., expandable frame **208** of FIG. **1**) made from a material such as Nitinol. Alternatively, the PCB substrate may be of such a thickness that the PCB substrate can be the frame itself. The transducer elements could also be constructed using discrete components.

FIG. **12A** shows a flexible printed circuit board substrate **1200a** that carries separate force sensor transducer elements **1202** (only one called out in FIG. **12A**) responsive to force, temperature sensor transducer elements **1204** (only one called out in FIG. **12A**) responsive to temperature, and ablation transducer elements **1206** (only one called out in FIG. **12A**) operable to ablate non-blood tissue. The various transducer elements **1202**, **1204**, **1206** share a common ground **1208**. The ablation and temperature sensor transducer elements **1206**, **1204**, respectively, share a common control lead **1210**. Control leads **1210** are coupled to a control system (not shown in FIG. **12A**). The preferred force sensor transducer element **1202** is a polymeric piezoelectric material. An example of a circuit that can be used to control and monitor such force sensor transducer elements **1202** is shown in FIG. **13**.

FIG. **12B** shows a flexible printed circuit board substrate **1200b** that carries separate force sensor transducer elements **1222** (only one called out in FIG. **12B**) responsive to force and elements with a combined temperature sensor and ablation transducer elements **1224** (only one called out in FIG. **12B**). Each of the transducer elements **1222**, **1224** has respective leads, collectively **1226**, coupled to a control system (not shown in FIG. **12B**). The combined temperature sensor and ablation transducer elements **1224** can be controlled in the same way as described for the embodiment of FIG. **7**. The force sensor transducer element **1222** can be controlled and monitored as described herein with reference to FIG. **13**.

FIG. **12C** shows a flexible printed circuit board substrate **1200c** that carries force sensor transducer elements **1232** (only one called out in FIG. **12C**) responsive to force, and combined or integrated temperature sensor and ablation transducer elements **1234** (only one called out in FIG. **12C**) responsive to temperature and operable to ablate non-blood tissue. The combined temperature sensor and ablation transducer elements **1234** are distinct from the force sensor transducer elements **1232**. Each of the various types of transducer elements **1232**, **1234** has respective leads, collectively **1236**, coupled to a control system (not shown in FIG. **12C**) possibly via a multiplexer (not shown in FIG.

12C). The combined temperature sensor and ablation transducer elements may be controlled in the same way as previously discussed with reference to FIG. 7.

FIG. 13 shows an embodiment of a circuit 1300 used to sense the forces the force sensor transducer elements (e.g., FIGS. 12A-12C) sense, according to one illustrated embodiment.

A force is exerted on a force sensor transducer element 1302 carried by a flexible PCB substrate 1304, by a bodily material 1306, for example blood or non-blood tissue.

A charge amplifier 1308 converts an output of the force sensor transducer element 1302 to a voltage which is digitized by an analog-to-digital (ADC) converter 1310. This voltage is proportional to the force exerted on the force sensor transducer element 1302 by the bodily material 1306, and the output may be indicative of a pressure. An ablation transducer element (e.g., electrode) can be used for temperature monitoring, as explained earlier, or a separate temperature sensor 1312 can be used. A capacitor 1314 can be used to isolate the RF from the DC current used for temperature sensing. Temperature sensing may be used by a temperature controller 1316 to control an ablation power source 1318 to cause an ablation transducer element 1320 to produce an appropriate amount of ablation (e.g., controlling time, temperature, current, power, etc.). A switch 1322 or valve may selectively couple the ablation power source 1318 to the ablation transducer element 1320.

When a polymeric piezoelectric material is used as the force sensor transducer element 1302, it is important to ensure the force sensor transducer element 1302 is sufficiently electrically insulated to eliminate any leakage current. A possible insulating material to use is silicone. Also, integrating an amplifier near the piezoelectric force sensor transducer element 1302 may improve the circuit performance and may make the circuit 1300 less susceptible to leakage current.

Although this circuit 1300 uses multiplexing via connectors 1330a, 1330b to measure the force exerted on the elements, it is also possible to forgo multiplexing and have a circuit dedicated for each element, or a combination of both techniques.

Note that the same piezoelectric sensing grid can also be used in alternate ways to differentiate non-blood tissue from blood. For example, it can be used as an ultrasonic transmitter and receiver to differentiate based on reflection or on damping coefficient.

Frame

The frame provides expansion and contraction capabilities for the component of the medical device (e.g., grid or array of transducer elements) used to distinguish between blood and non-blood tissue. The transducer elements used to sense a parameter or characteristic to distinguish between blood and non-blood tissue may be mounted or otherwise carried on a frame, or may form an integral component of the frame itself. The frame may be flexible enough to slide within a catheter sheath in order to be deployed percutaneously. FIG. 2, discussed previously, showed one embodiment of such a frame. Additional embodiments of frames are shown in FIGS. 14A, 14B, 15A, 15B, 15C, 16A and 16B.

FIG. 14A shows a frame 1400 made from a number of helical members 1402a, 1402b (collectively 1402) in an unexpanded configuration and positioned within a catheter sheath 1404 of a catheter 1408. FIG. 14B shows the frame 1400 extended outside of the catheter sheath 1404 and in an expanded configuration.

The helical members 1402 may be disposed about a shaft 1410. The helical members 1402 may be positioned between

opposing stops 1412a, 1412b, which engage the ends of the helical members 1402 to cause expansion. While two helical members are shown, some embodiments may employ a greater or fewer number of helical members 1402.

The frame 1400 is expanded by retracting a shaft 1410. Retracting the shaft 1410 causes the midpoint of the helical members to be forced outward and move toward the interior surface of the cavity in which the frame is positioned. FIG. 14B shows that some of the helical members 1402 are oriented in a clockwise direction and others are oriented in a counter clockwise direction. The opposing directions cause the helical members 1402a, 1402b to cross over and form a grid.

The helical members 1402 may be constructed of many different types of material including solid wire (such as stainless steel), hollow tube, carbon fiber, or a flexible PCB with a fibreglass or Nitinol backing. The helical members 1402 may form an integral component of the sensing and ablation transducer elements. FIG. 4 provided several examples of how elements could be constructed from solid wire, hollow tube, carbon fiber, or flexible PCB. When the transducer elements form an integral component of the frame, the material to be used for the frame requires proper mechanical and electrical properties. If the device is distinguishing between blood and non-blood tissue using flow sensing, the material used for the helical members 1402 preferably has a significant change in resistance with temperature that is independent of helical members 1402 deformation. Also, a resistance of several ohms per centimetre or higher is preferable as it will reduce the amount of current needed to heat the transducer element. The helical members 1402 may also act as a support for a secondary assembly that carries the sensing and ablation transducer elements. An example of this is a stainless steel or Nitinol structure used to expand transducer elements made with a flexible PCB substrate.

FIGS. 15A-15C show a frame 1500, according to another illustrated embodiment.

The frame 1500 includes a single helical member 1502, a plurality of ribs 1504, and a shaft 1506, oriented approximately parallel to a longitudinal axis of a catheter 1508. The sensor and ablation transducer elements are located along the helical member 1502 and ribs 1504.

FIG. 15A shows the frame 1500 in its unexpanded or contracted configuration, positioned within a catheter sheath 1510 of the catheter 1508. In the unexpanded or contracted configuration, the ribs 1504 are compressed against the shaft 1506 and the single helical member 1502 is wound around the ribs 1504. The catheter sheath 1510 is inserted partially into the lumen, cavity, chamber or atrium that the device is to operate in. The frame 1500 is then pushed out of the sheath 1510 into the chamber and then expanded.

FIG. 15B shows the frame 1500 in a partially expanded configuration. The frame 1500 is expanded by first unwinding the helical member 1502. The shaft 1506 is rotated, which causes the helical member 1502 to unwind and expand outward from the shaft 1506.

FIG. 15C shows the frame 1500 in a fully expanded configuration. The frame 1500 is fully expanded by retracting the shaft 1506, which causes the ribs 1504 to bow outwards and move both the helical member 1502 and ribs 1504 to be proximate to the non-blood tissue that forms the interior surface of the chamber. The ribs 1504 and helical member 1502 may only be physically attached at the proximal and distal ends of the ribs 1504 and helical member 1502, or the ribs 1504 may have loops spaced along their length through which the helical member 1502 slides.

There are several variations on the example shown in FIGS. 15A-15C. These include a frame in which the helical member is inside the ribs, and pushes the ribs outward. Alternatively, a frame may include a helical member that is positioned inside the ribs, and the ribs are only attached at the proximal or distal end.

The same principles regarding construction and composition of the ribs described for the frame 1400 of FIGS. 14A and 14B may be applied to the frame 1500 of FIGS. 15A-15C.

FIGS. 16A and 16B show an embodiment a frame 1600 made using one or more inflatable members 1602. The particular inflatable member 1602 shown is approximately spherical in shape, although it is possible to construct a frame using inflatable members that are oblong as well.

FIG. 16A shows the frame 1600 in an inflated or expanded configuration. FIG. 16B shows a cross section of the frame 1600. The preferred method of expanding this frame 1600 is to inflate via one or more ports 1604 with a fluid. A fluid, such as saline, that is not dangerous if inadvertently released into the body may be particularly suitable. The port 1604 may be fluidly communicatively coupled to source of fluid, for example via one or more lumens of a catheter 1606. The source of fluid may be pressurized. The inflatable member 1602 may be folded inside a catheter sheath 1608 for percutaneous or intravascular delivery. The inflatable member 1602 may be withdrawn or pushed from the catheter sheath 1608 when in a desired position in the bodily organ.

This inflatable member may have one or more passages, collectively 1610, (only three called out in FIGS. 16A and 16B) opening to the exterior surface 1612. The passages 1610 may provide fluid communication through the inflatable member 1602. For example, the passages 1610 may connect to a hollow interior cavity 1614. These passages 1610 allow blood to flow through the frame 1600 even when the frame 1600 is inflated sufficiently to be in contact with the interior surface of the lumen, cavity, chamber or atrium in which the frame 1600 is located. Thus, blood may flow from a downstream side or position, to and open stream side [D1] or position, relative to the position of the frame 1600, even when inflated and in the expanded configuration. Such advantageously prevents occlusion.

An advantageous design feature when building an inflatable member that has interior structures, such as blood flow passages 1610 or an inner cavity 1614 is that the walls that form those interior structures should be reinforced to prevent the wall from collapsing or buckling. Such reinforcement can be accomplished in variety of ways. For example, by creating the inner walls using much thicker material, creating ribbed walls with alternating thinner or thicker sections, collectively 1616, (only three called out in FIG. 16B), or reinforcing the walls with spring like wires.

An inflatable frame 1600 as described may be created using a material such as latex. This device may be used as a supporting frame for elements, for example constructed using flexible printed circuit boards.

Joint Assembly

Several of the frames discussed in the preceding section employ joints where transducer elements cross over one another. FIGS. 17A-17E and FIGS. 18A-18B show several examples of different structures that can be used. FIG. 17A shows several strips 1702a-1702c (collectively 1702) of flexible printed circuit board substrate at different orientations to one another. Such strips 1702 may be used to build the ribs, struts, or frame members mentioned previously. Where the strips 1702 cross, they may be joined by a hinge 1704a, 1704b (collectively 1704) that attaches both strips

1702. The hinge 1704 may, for example extend through both strips 1702. The 1702 strips are still able to swivel around the hinge point. The preferred place to join the strips 1702 is at the connecting points between transducer elements 1708a, 1708b (collectively 1708, only two called out in FIG. 17A). If the transducer elements 1708 are designed to share leads, the hinge can be used to electrically connect the transducer elements 1708 that have an end coincident with the joint. Alternatively the transducer elements 1708 may be electrically insulated from the hinge 1704 with no electrical contact points between the strips 1702. The transducer elements 1708 between the hinges 1704 may be used to distinguish between blood and non-blood tissue and/or to ablate. Leads may extend along each strip 1702 back to the catheter (not shown in FIG. 17A) and to a control system (not shown in FIG. 17A).

FIG. 17B shows several strands 1722a-1722c (collectively 1722) of carbon fiber at different orientations to one another. Such strands 1722 may be used to build the ribs, struts, or frame members mentioned previously. Where the strands 1722 cross, the carbon fiber strands 1722 are pinched or crimped 1724a, 1724b (collectively 1724) together, for example by means of a crimping mechanism. The crimping mechanism may be made from materials such as carbon fibre, carbon paste (cured by heating) metal, or glue. Pinching the carbon fibre together at the joint enables the strands to swivel about the joint. The carbon fibre between each connecting point can be used as a transducer element 1726 (only one called out in FIG. 17B) to sense flow, sense temperature and/or to ablate. A lead 1728 (only one called out in FIG. 17B) can be connected at each joint to control the transducer elements 1726 as shown by the circuit 800 of FIG. 8.

FIG. 17C shows several wires or hollow tubes 1730a-1730b (collectively 1730) made of material such as stainless steel or Nitinol, at different orientations from one another. Such wires or tubes 1730 may be used to build the ribs, struts, or frame members mentioned previously. Where the wires or tubes 1730 cross, they are connected at joints or connection points 1732a, 1732b (collectively 1732) for example by being fused together using spot or laser welding. The wire or tube between each connecting point can be used as a transducer element, collectively 1734 (only one called out in FIG. 17C), to sense flow, sense temperature and/or to ablate. A lead, collectively 1736 (only one called out in FIG. 17C), can be connected at each joint or connection point 1732 to control the transducer elements 1734 as shown by the circuit in FIG. 8.

FIG. 17D shows several strips 1742a-1742c (collectively 1742) of flexible printed circuit board substrate at different orientations to one another. Such strips 1742 may be used to build the ribs, struts, or frame members mentioned previously. Where the strips 1742 cross 1744a, 1744b (collectively 1744), they are not mechanically joined, but allowed to slide over top of each other. Since a fixed hinge point does not exist in the configuration, it is necessary to be able to determine where the strips 1742 cross when the frame is in the expanded configuration inside a body lumen, cavity, chamber or atrium in order to properly determine the location of openings or ports of the lumen, cavity, chamber or atrium. One method of doing this is to make use of the heating and temperature sensing capabilities of the transducer elements 1746 (only one called out in FIG. 17D). Each transducer element 1746 should be heated slightly in turn (such as several degrees above blood temperature) while other transducer elements 1746 are sensing temperature. If the transducer element 1746 being heated is located at a

crossing point, a different transducer element **1746** sensing temperature, but also located at the same crossing point will sense a temperature increase. All or most pairs of transducer elements **1746** that cross may be determined using such an approach

FIG. **17E** shows a flexible printed circuit board substrate **1752** in a leaf shape. Such a PCB substrate **1752** is used to cover one portion of the interior surface of the body cavity. Multiple such PCB substrates may be joined together as shown in FIG. **2**, to cover at least a significant portion of the surface of a lumen, cavity, chamber or atrium. These PCB substrates may surround a frame that is used to push them outward and proximate to the surface. The PCB substrates may overlap. Overlapping transducer elements **1754a**, **1754b** (collectively **1754**, only two called out in FIG. **17E**) may be determined using the method described for the embodiment of FIG. **17D**.

FIG. **18A** shows a frame **1800** formed from metal strips **1802a-1802c** (collectively **1802**) formed to have flexure points **1804**. Such strips **1802** may be used to build the ribs, struts, or frame members mentioned previously. The ribs, struts, or frames have crossing points **1806a**, **1806b** (collectively **1806**). At the crossing points **1806** the metal strips **1802** are fused together using spot welding. The metal strips **1802** are formed to have a flexure **1804** on either side of the crossing point **1806**. The flexure **1804** enables the strips **1802** to bend which may be beneficial for the expansion and contraction of the frame **1800**. A portion of the strip **1802** between each connecting or crossing point **1806** can be used as a transducer element **1808** (only one called out in FIG. **18A**) to sense flow, sense temperature and/or to ablate non-blood tissue. A lead **1810** (only one called out in FIG. **18A**) can be connected at each joint to control the transducer elements **1808** as shown by the circuit in FIG. **8**.

FIG. **18B** shows a frame **1820** formed from metal strips **1822a-1822d** (collectively **1822**) formed to have slots **1824** (only one illustrated). Such strips **1822** may be used to build the ribs, struts, or frame members mentioned previously. The ribs, struts, or frames have crossing points **1826a-1826d** (collectively **1826**). At the crossing point **1826** of two strips **1822**, one of the strips has a slot **1824** and the other strip **1822** slides through the slot **1824**. The slot **1824** may be formed in a strip **1822** by joining two thin strips **1828a**, **1828b** by spot welds **1830** (only two called out in FIG. **18B**). It is possible to connect the control leads **1832** to the spot welds **1830** which are located between the crossing points **1826** and use the portions of the strips **1822** between each connecting or crossing point **1826** as a transducer element to sense flow, sense temperature and/or ablate non-blood tissue. However, this method will require approximately 40% more wires than connecting the control leads at the crossing points.

The various embodiments described above can be combined to provide further embodiments. All of the U.S. patents, U.S. patent application publications, U.S. patent applications, foreign patents, foreign patent applications and non-patent publications referred to in this specification and/or listed in the Application Data Sheet are incorporated herein by reference, in their entirety. Aspects of the invention can be modified, if necessary, to employ systems, circuits and concepts of the various patents, applications and publications to provide yet further embodiments of the invention.

These and other changes can be made to the invention in light of the above-detailed description. In general, in the following claims, the terms used should not be construed to limit the invention to the specific embodiments disclosed in

the specification and the claims, but should be construed to include all medical treatment devices in accordance with the claims. Accordingly, the invention is not limited by the disclosure, but instead its scope is to be determined entirely by the following claims.

The invention claimed is:

1. A medical system, comprising:

a medical device including a frame positionable in at least a portion of a bodily organ, the frame including a plurality of transducers; and

electronic circuitry and a computing system coupled to the medical device and configured to:

apply a signal including a first frequency to a first transducer of the plurality of transducers;

measure a phase shift associated with the signal caused by contact between the first transducer and bodily material within the at least the portion of the bodily organ;

generate a map of at least some of a physical interior surface of a tissue wall of the bodily organ based at least on an analysis of the phase shift; and

cause at least one display device coupled to the computing system to display output representing at least part of the map.

2. The medical system of claim 1, wherein:

the electronic circuitry and the computing system coupled to the medical device are configured to computationally discriminate between fluid and non-fluid tissue in the bodily organ based at least on the analysis of the phase shift; and

the generating of the map of the at least some of the physical interior surface of the tissue wall is based at least on the computationally discriminating between the fluid and the non-fluid tissue in the bodily organ.

3. The medical system of claim 2, wherein the analysis of the phase shift includes determining a permittivity of the fluid or non-fluid tissue based at least on the phase shift.

4. The medical system of claim 1, wherein the electrical circuitry includes a phase meter configured to measure the phase shift associated with the signal caused by the contact between the first transducer and the bodily material within the at least the portion of the bodily organ.

5. The medical system of claim 1, wherein the electrical circuitry includes a selector configured to select the first frequency as opposed to a second frequency applicable to the first transducer of the plurality of transducers.

6. The medical system of claim 1, wherein the electrical circuitry includes a resistor configured to receive and output the signal including the first frequency.

7. The medical system of claim 1, wherein the bodily organ is a heart, and the bodily material within the at least the portion of the bodily organ is blood or tissue forming the physical interior surface of the tissue wall of the bodily organ.

8. The medical system of claim 1, wherein:

the electronic circuitry and the computing system coupled to the medical device are configured to apply a respective signal including the first frequency to each transducer of the plurality of transducers, and, for each transducer of the plurality of transducers, measure a respective phase shift associated with the respective signal caused by contact between the transducer and bodily material within the at least the portion of the bodily organ; and

the generating of the map of the at least some of the physical interior surface of the tissue wall of the bodily organ is based at least on an analysis of the respective phase shifts.

9. The medical system of claim 8, wherein:
 the physical interior surface of the tissue wall of the
 bodily organ is interrupted by one or more ports in fluid
 communication with the bodily organ; and
 the map indicates positions of the one or more ports.

10. The medical system of claim 1, further comprising an
 ablation source, wherein each transducer of at least some of
 the plurality of transducers is coupled to the ablation source
 and is selectively operable to ablate a portion of non-fluid
 tissue in the bodily organ.

11. The medical system of claim 1, further comprising an
 ablation source, wherein each transducer of at least the first
 transducer of the plurality of transducers is coupled to the
 ablation source and is selectively operable to ablate a portion
 of non-fluid tissue in the bodily organ.

12. The medical system of claim 10, wherein the bodily
 organ is a heart, the non-fluid tissue is non-blood tissue
 forming a wall of the heart, and wherein each transducer of
 the plurality of transducers is responsive to electrical poten-
 tial of the non-blood tissue.

13. The medical system of claim 10, wherein each trans-
 ducer of the plurality of transducers is responsive to elec-
 trical potential of the non-fluid tissue, and wherein the
 computing system is configured to produce an indication of
 whether the ablation was successful based on at least one
 sensed electrical potential of the non-fluid tissue.

14. The medical system of claim 10, wherein each trans-
 ducer of the plurality of transducers comprises a temperature
 sensor element.

15. The medical system of claim 1, wherein each trans-
 ducer of at least the first transducer of the plurality of
 transducers comprises a temperature sensor element.

16. The medical system of claim 1, wherein each trans-
 ducer of at least the first transducer of the plurality of
 transducers comprises a permittivity sensor element.

17. The medical system of claim 1, wherein each trans-
 ducer of at least the first transducer of the plurality of
 transducers comprises a flow sensor element.

18. The medical system of claim 1, wherein the frame of
 the medical device is selectively moveable between an
 unexpanded configuration and an expanded configuration,
 the medical device sized to be delivered intravascularly in a
 case where at least the frame of the medical device is in the
 unexpanded configuration, and wherein each transducer of
 the plurality of transducers is configured to sense, in a case
 where at least the frame of the medical device is in the
 expanded configuration, at least one characteristic indicative
 of whether blood or non-blood tissue is present.

19. The medical system of claim 1, wherein the medical
 system further comprises at least one communications path
 communicatively coupling the plurality of transducers and
 the computing system, the communications path including a
 multiplexer and a demultiplexer, the multiplexer located
 along the communications path at a first distance from the
 computing system, and the demultiplexer located along the

communications path at a second distance from the com-
 puting system, the second distance greater than the first
 distance.

20. The medical system of claim 1, further comprising a
 switch operable to selectively switch at least one transducer
 of the plurality of transducers between an ablation mode and
 a sense mode, wherein the at least one transducer of the
 plurality of transducers is configured to ablate non-blood
 tissue in the ablation mode and to sense, in the sense mode,
 at least one characteristic indicative of whether blood or
 non-blood tissue is present.

21. The medical system of claim 1, wherein each trans-
 ducer of at least some transducers of the plurality of trans-
 ducers includes a temperature sensor element.

22. The medical system of claim 1, wherein each trans-
 ducer of at least some transducers of the plurality of trans-
 ducers includes an ablation element.

23. The medical system of claim 1, wherein each trans-
 ducer of at least some transducers of the plurality of trans-
 ducers includes a permittivity sensor element.

24. The medical system of claim 1, wherein each trans-
 ducer of at least some transducers of the plurality of trans-
 ducers includes a flow sensor element.

25. A method of operating a medical system, the method
 executed by electronic circuitry and a computing system of
 the medical system, the electronic circuitry and the comput-
 ing system coupled to a medical device of the medical
 system, the medical device including a frame positionable in
 at least a portion of a bodily organ, the frame including a
 plurality of transducers, and the method comprising:
 applying a signal including a first frequency to a first
 transducer of the plurality of transducers;
 measuring a phase shift associated with the signal caused
 by contact between the first transducer and bodily
 material within the at least the portion of the bodily
 organ;
 generating a map of at least some of a physical interior
 surface of a tissue wall of the bodily organ based at
 least on an analysis of the phase shift; and
 causing at least one display device coupled to the com-
 puting system to display output representing at least
 part of the map.

26. The method of claim 25, wherein the analysis of the
 phase shift includes determining a permittivity of fluid or
 non-fluid tissue based at least on the phase shift.

27. The method of claim 25, wherein:
 the physical interior surface of the tissue wall of the
 bodily organ is interrupted by one or more ports in fluid
 communication with the bodily organ; and
 the map indicates positions of the one or more ports.

28. The method of claim 25, wherein the bodily organ is
 a heart, and the bodily material within the at least the portion
 of the bodily organ is blood or tissue forming the physical
 interior surface of the tissue wall of the bodily organ.

* * * * *

专利名称(译)	用于身体内腔的医疗设备，例如中庭		
公开(公告)号	US10499986	公开(公告)日	2019-12-10
申请号	US15/663077	申请日	2017-07-28
[标]申请(专利权)人(译)	卡尔蒂姆公司		
申请(专利权)人(译)	KARDIUM INC.		
当前申请(专利权)人(译)	KARDIUM INC.		
[标]发明人	GELBART DANIEL GOERTZEN DOUGLAS WAYNE LOPES FERNANDO LUIS DE SOUZA		
发明人	GELBART, DANIEL GOERTZEN, DOUGLAS WAYNE LOPES, FERNANDO LUIS DE SOUZA		
IPC分类号	A61B18/14 A61B5/06 A61B5/00 A61B18/00 A61B18/20 A61B18/18 A61B18/02		
CPC分类号	A61B5/4875 A61B5/065 A61B5/06 A61B18/1492 A61B2018/00791 A61B2018/00702 A61B18/18 A61B2018/00577 A61B2018/025 A61B2018/00214 A61B2018/00351 A61B18/20		
其他公开文献	US20170333124A1		
外部链接	Espacenet		

摘要(译)

可定位在身体器官（例如心脏）的腔中的设备可以区分流体（例如血液）和非流体组织（例如心脏壁）以提供指示位置和/或位置的信息或映射装置在空腔中的方向。区分可以基于流量或其他一些特性，例如介电常数或力。该设备可以基于该信息或映射选择性地消融非流体组织的部分。该设备可以检测指示消融是否成功的特征（例如，电势）。该装置可以包括多个换能器，其以未扩张的构造在血管内被引导并且以扩张的构造定位在非流体组织附近。膨胀机构可以包括一个或多个螺旋构件或一个或多个可膨胀构件。

