



(19) **United States**

(12) **Patent Application Publication**  
**Greenberg et al.**

(10) **Pub. No.: US 2018/0345019 A1**

(43) **Pub. Date: Dec. 6, 2018**

(54) **CORTICAL INTERFACE FOR MOTOR SIGNAL RECORDING AND SENSORY SIGNAL STIMULATION**

*H05K 1/11* (2006.01)

*H05K 1/18* (2006.01)

(52) **U.S. Cl.**

CPC . *A61N 1/36082* (2013.01); *H05K 2201/0154* (2013.01); *A61B 5/04001* (2013.01); *A61N 1/0531* (2013.01); *A61N 1/0534* (2013.01); *A61N 1/0539* (2013.01); *H01L 2224/85099* (2013.01); *H01L 2224/48465* (2013.01); *H01L 2224/48227* (2013.01); *H01L 2224/45144* (2013.01); *H01L 2224/05599* (2013.01); *A61N 1/375* (2013.01); *A61B 5/6868* (2013.01); *H01L 2224/85399* (2013.01); *H01L 2924/3011* (2013.01); *H05K 1/118* (2013.01); *H05K 1/189* (2013.01); *H05K 2201/10098* (2013.01); *A61B 5/4064* (2013.01)

(71) Applicant: **SECOND SIGHT MEDICAL PRODUCTS, INC.**, Sylmar, CA (US)

(72) Inventors: **Robert J. Greenberg**, Los Angeles, CA (US); **David Daomin Zhou**, Valencia, CA (US); **Brian V. Mach**, Santa Clarita, CA (US); **Neil Hamilton Talbot**, La Crescenta, CA (US); **Rongqing Dai**, Valencia, CA (US); **Richard Agustin Castro**, Santa Monica, CA (US); **Kelly H. McClure**, Simi Valley, CA (US)

(73) Assignee: **SECOND SIGHT MEDICAL PRODUCTS, INC.**, Sylmar, CA (US)

(21) Appl. No.: **16/044,379**

(22) Filed: **Jul. 24, 2018**

**Related U.S. Application Data**

(62) Division of application No. 13/473,470, filed on May 16, 2012.

(60) Provisional application No. 61/486,704, filed on May 16, 2011.

**Publication Classification**

(51) **Int. Cl.**

*A61N 1/36* (2006.01)

*A61B 5/00* (2006.01)

*A61B 5/04* (2006.01)

*A61N 1/05* (2006.01)

*A61N 1/375* (2006.01)

(57) **ABSTRACT**

The present invention consists of an implantable device with at least one package that houses electronics that sends and receives data or signals, and optionally power, from an external system through at least one coil attached to the at least one package and processes the data, including recordings of neural activity, and delivers electrical pulses to neural tissue through at least one array of multiple electrodes that is/are attached to the at least one package. The invention, or components thereof, is/are intended to be installed in the head, or on or in the cranium or on the dura, or on or in the brain. Variations of the embodiments depend on the physical locations of the coil(s), package(s) and array(s) with respect to the head, cranium, dura, and brain. Novel features of the present invention include the small size of the implantable package which houses the controller, the high number of electrodes that are provided for stimulation and/or sensing and stimulation, and the methods for manufacturing such a device. These features have unique applications in neural stimulation to treat or prevent disorders or disease.

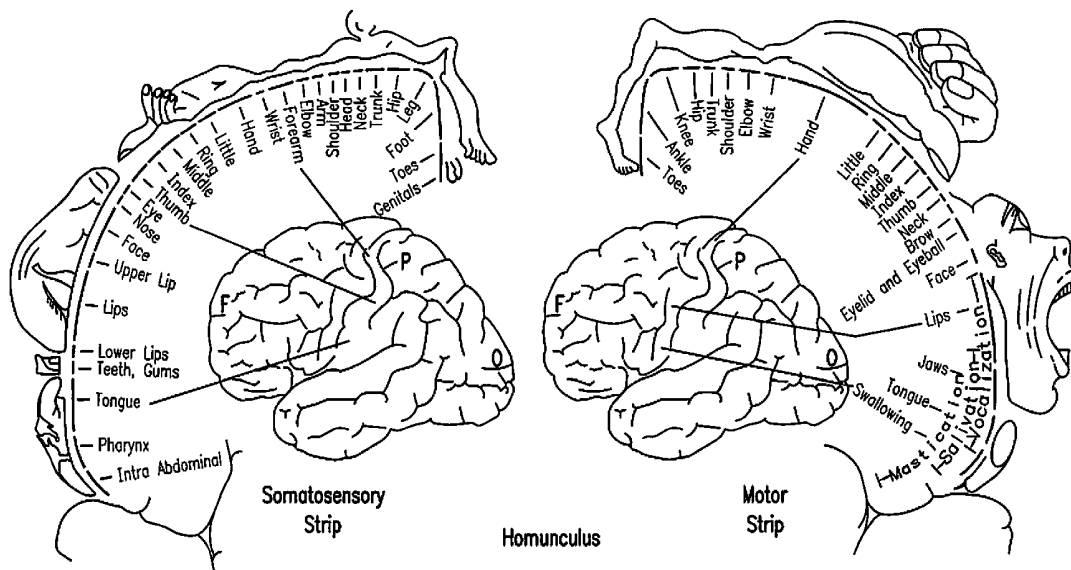

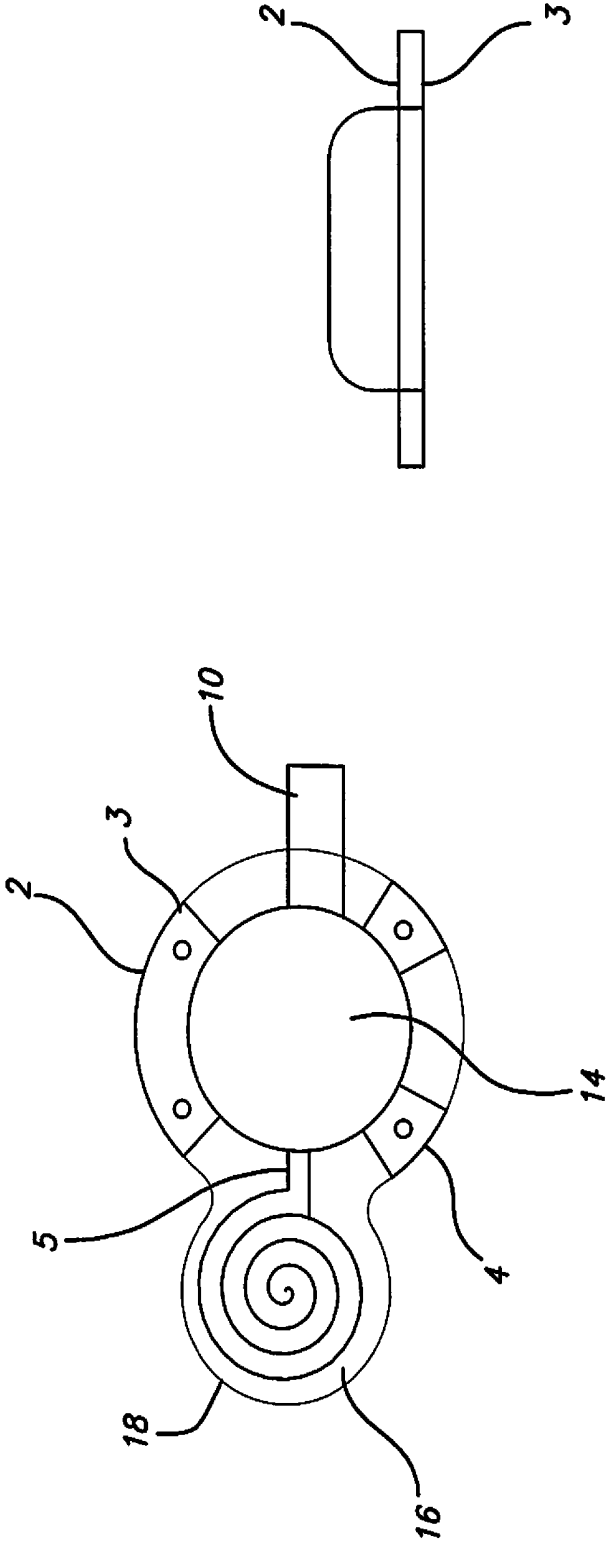

FIG. 1

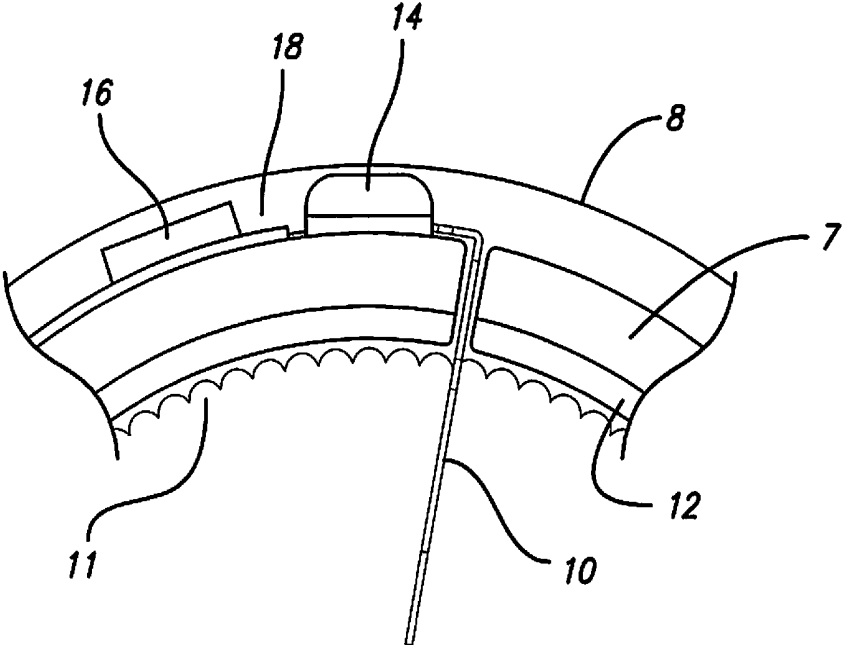

FIG. 2A

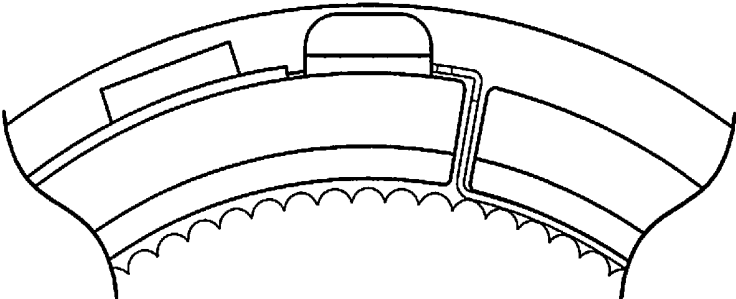

FIG. 2B

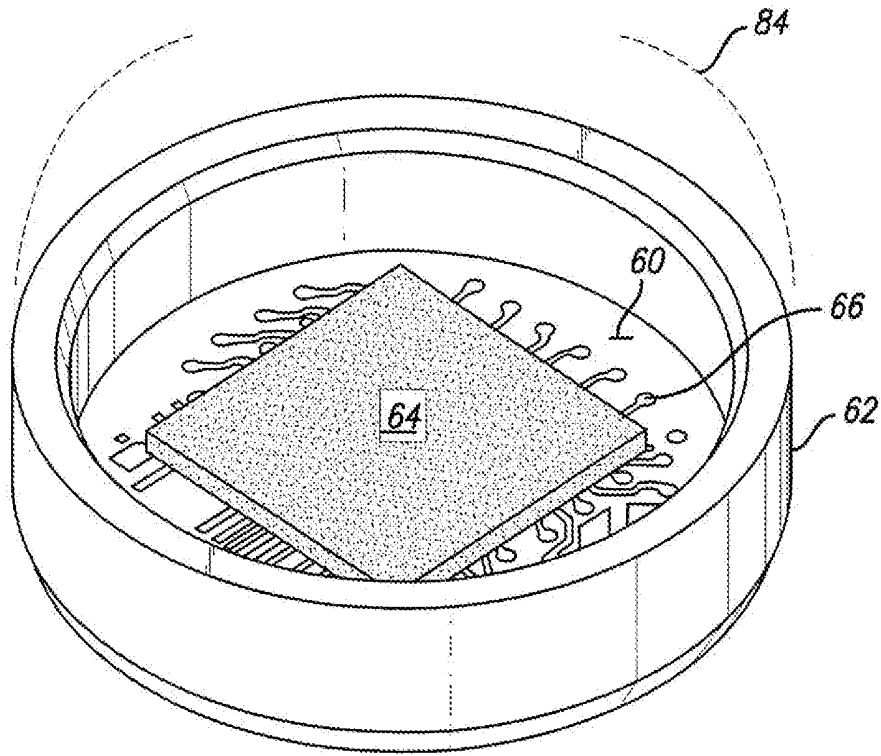

FIG. 3

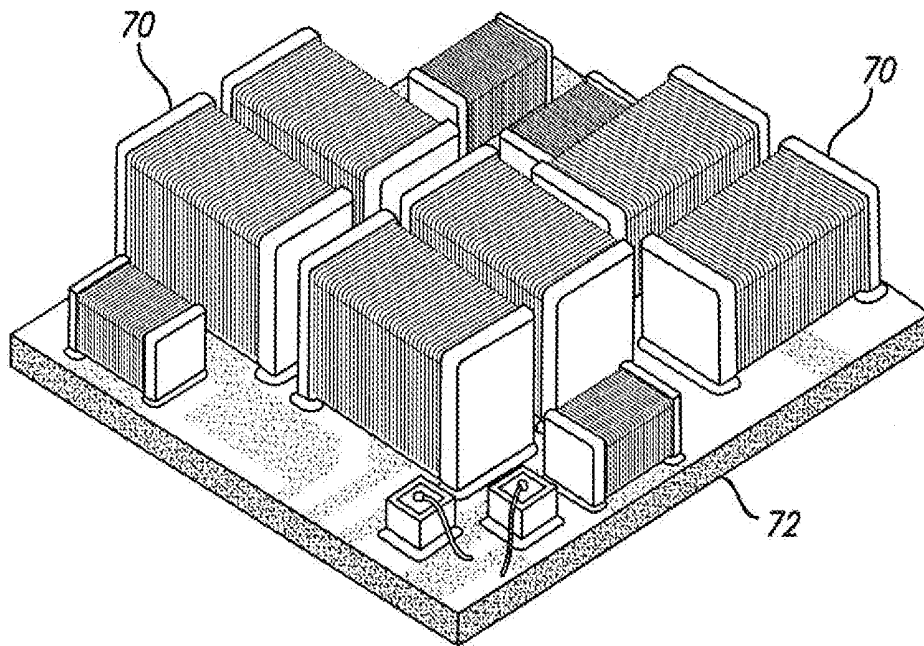

FIG. 4

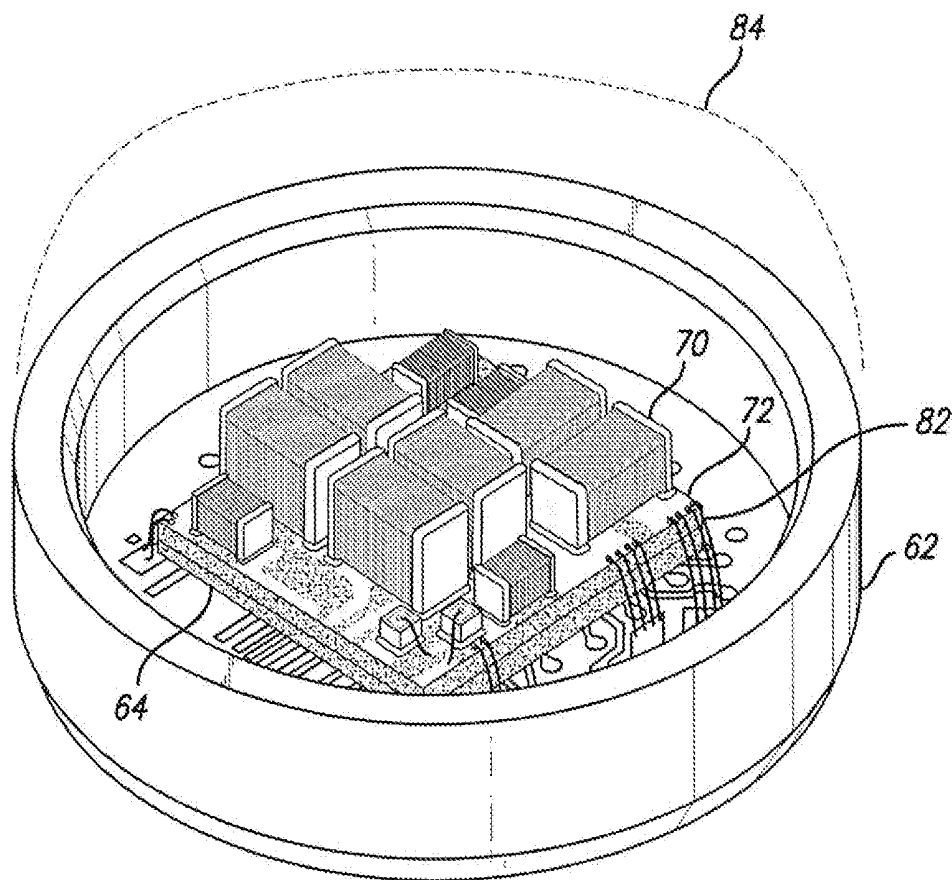

FIG. 5

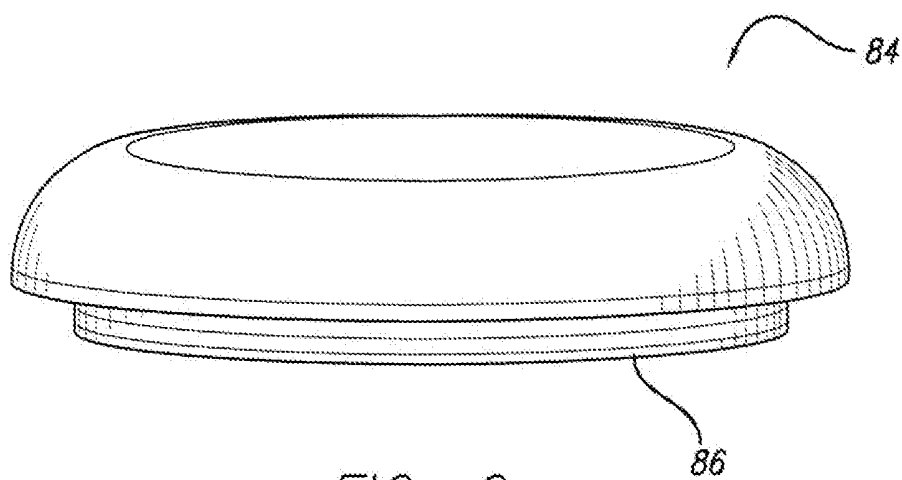

FIG. 6

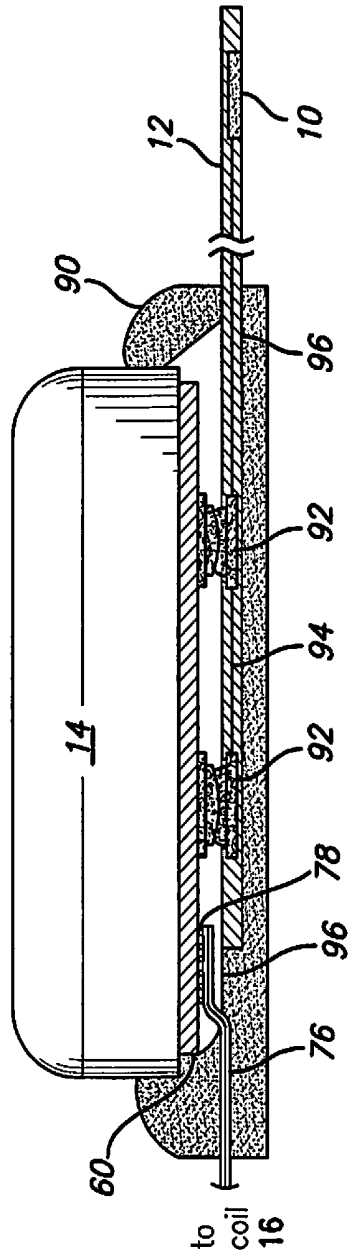

FIG. 7

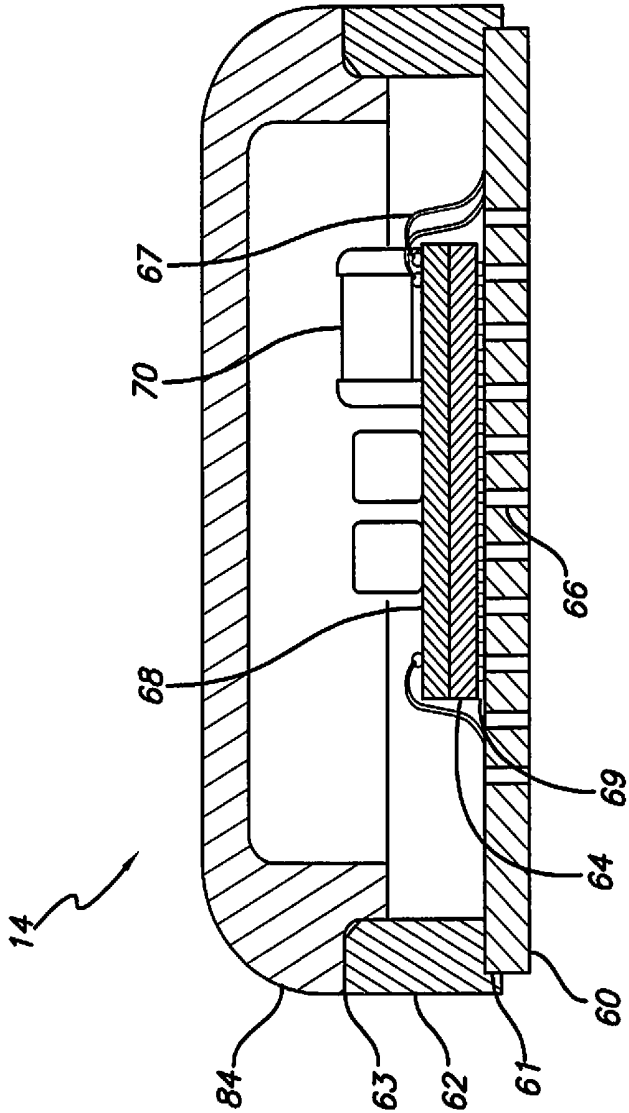

FIG. 8

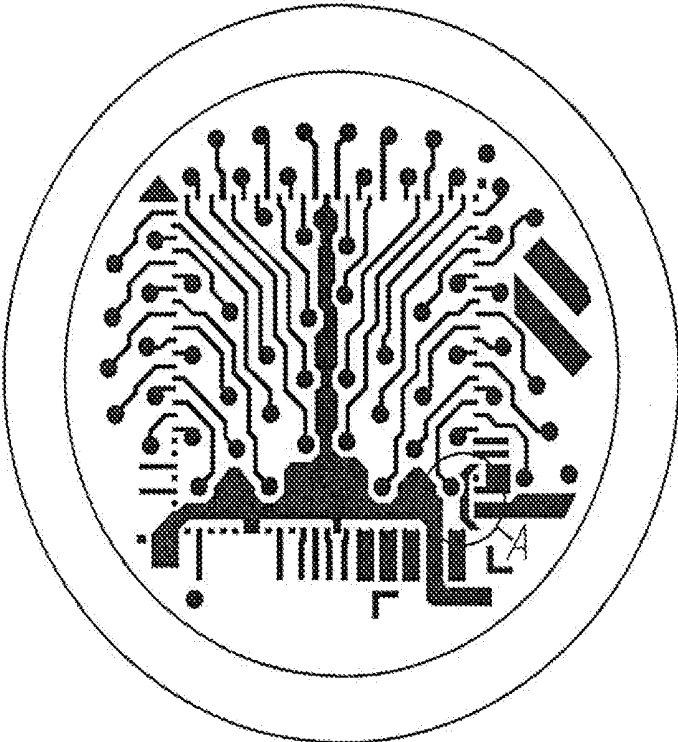

FIG. 9

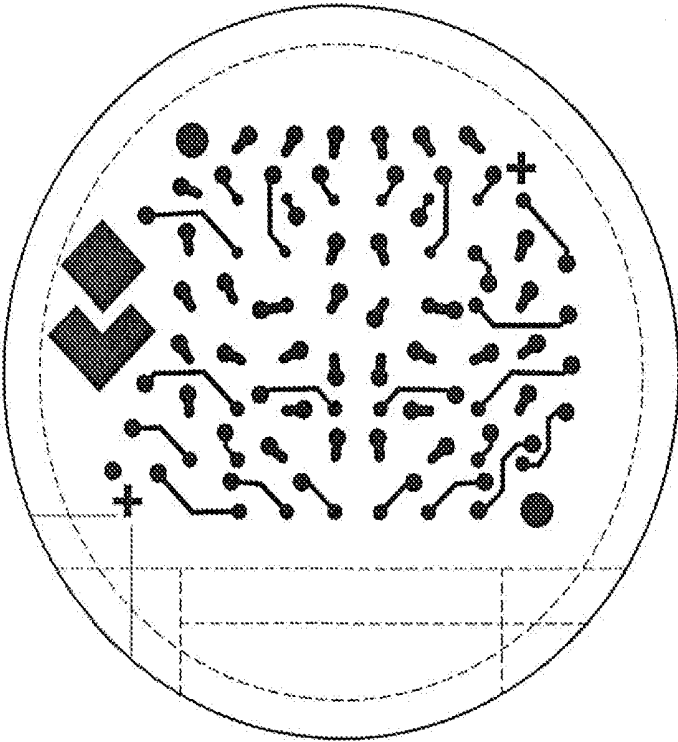

FIG. 10A

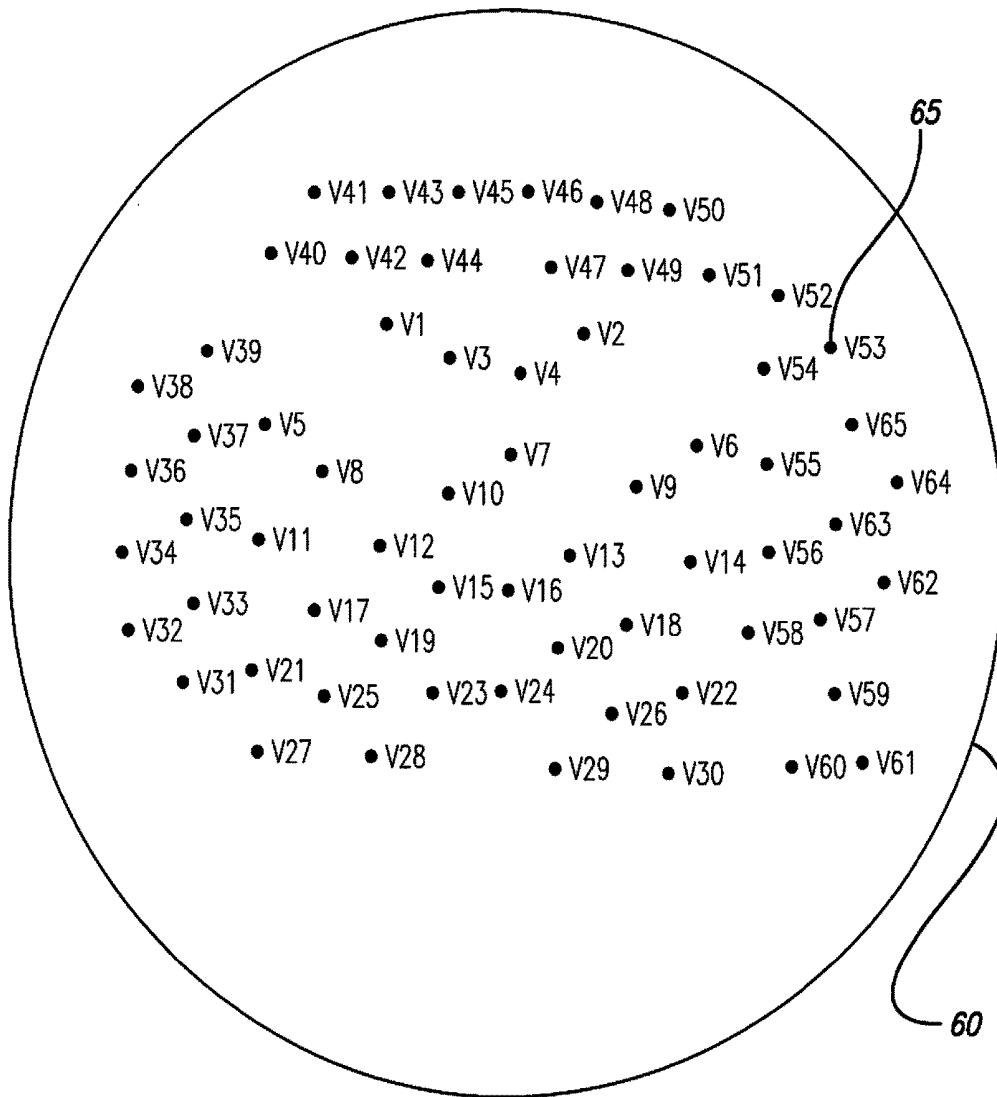

FIG. 10B

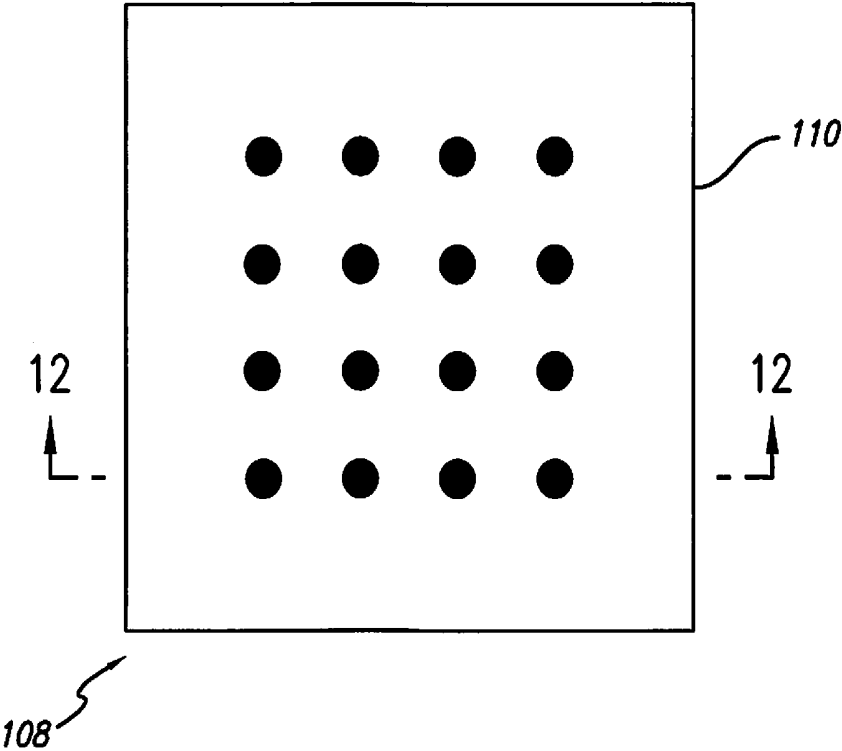

FIG. 11

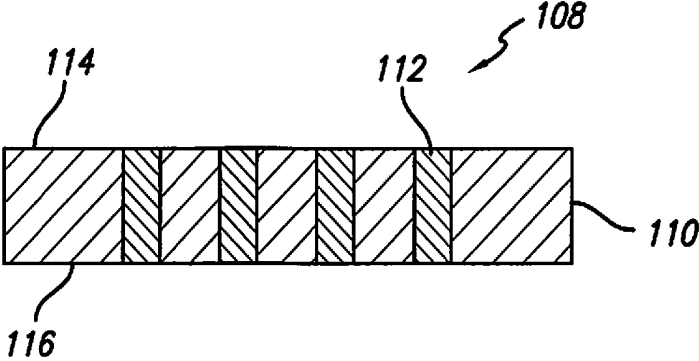

FIG. 12

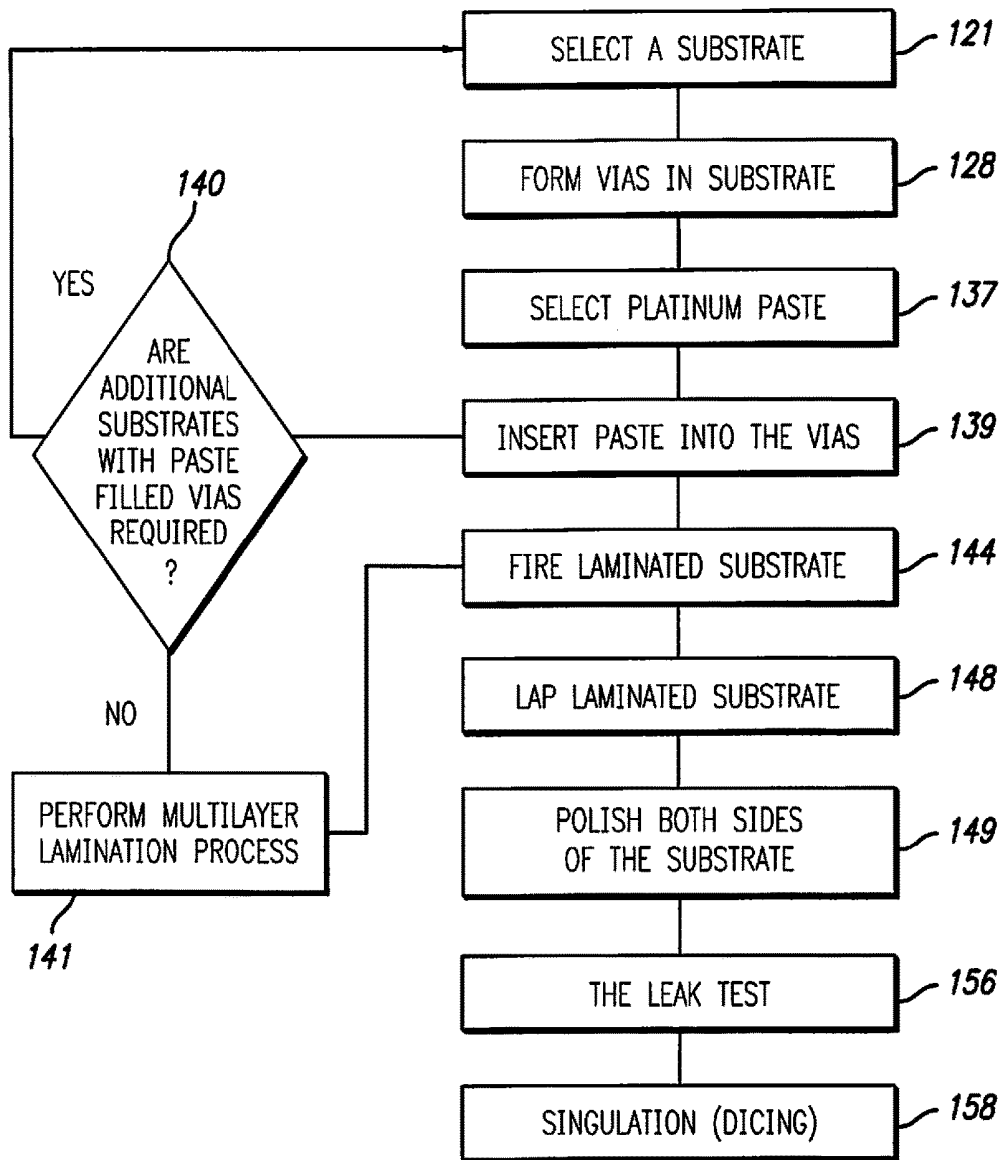

FIG. 13



FIG. 14A

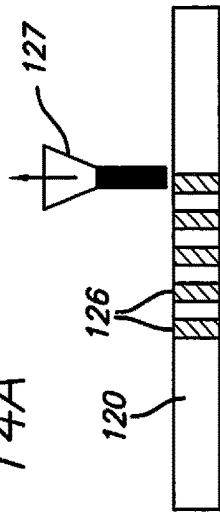

FIG. 14C

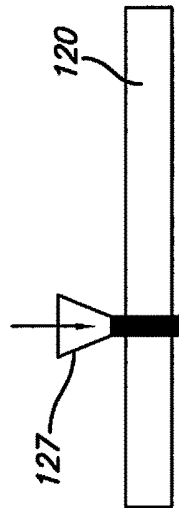

FIG. 14B

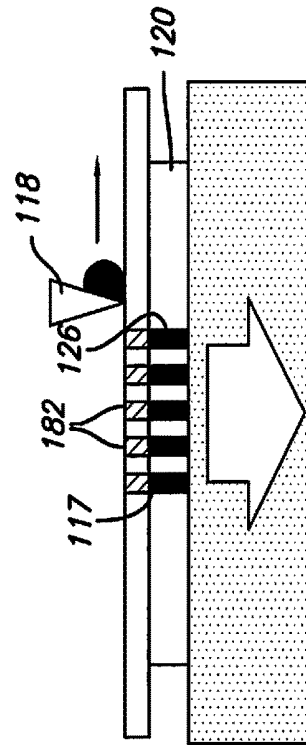

FIG. 14E

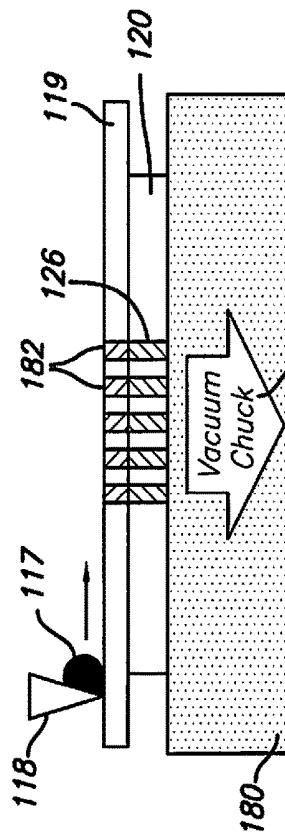

FIG. 14D



FIG. 14F

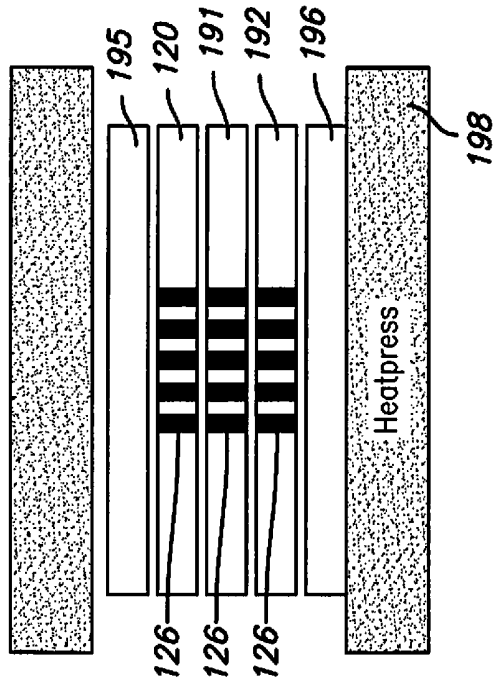

FIG. 14G

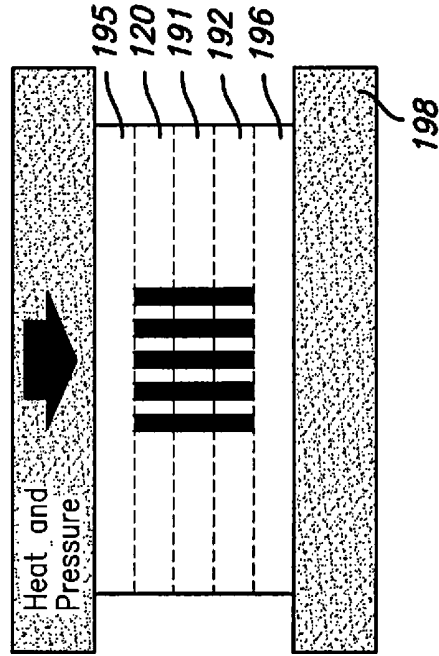

FIG. 14H

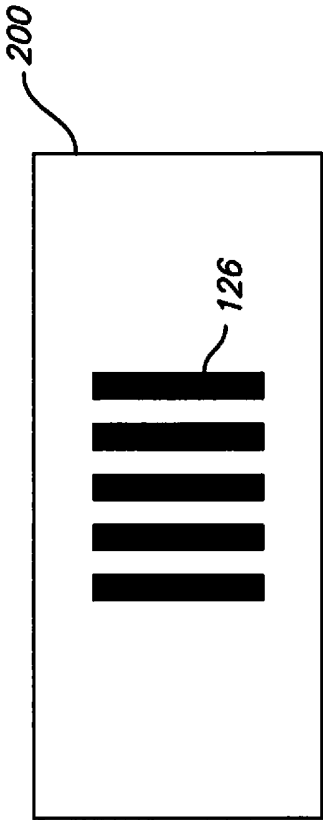

FIG. 14I

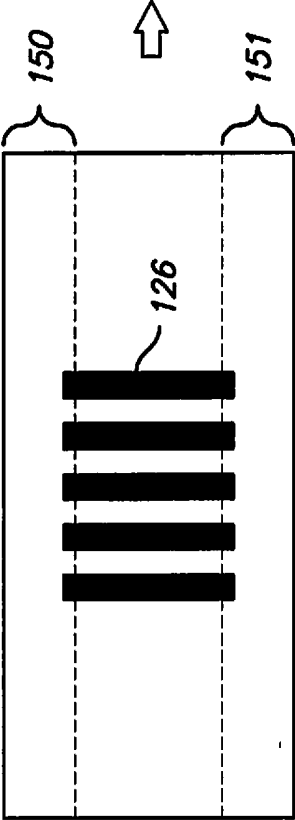

FIG. 14J



FIG. 14K

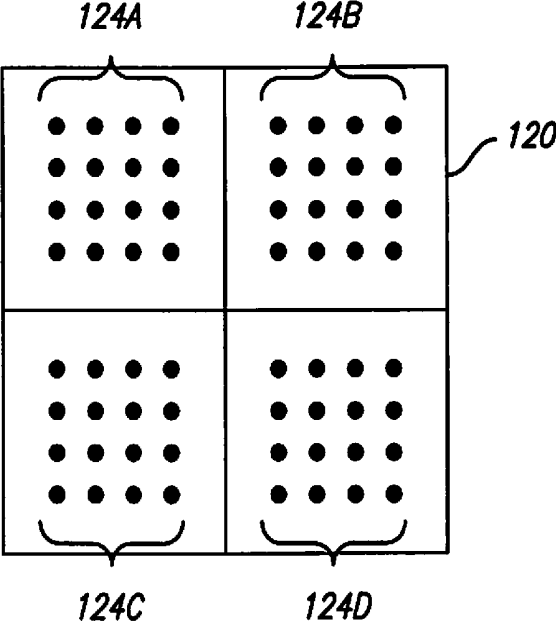

FIG. 14L

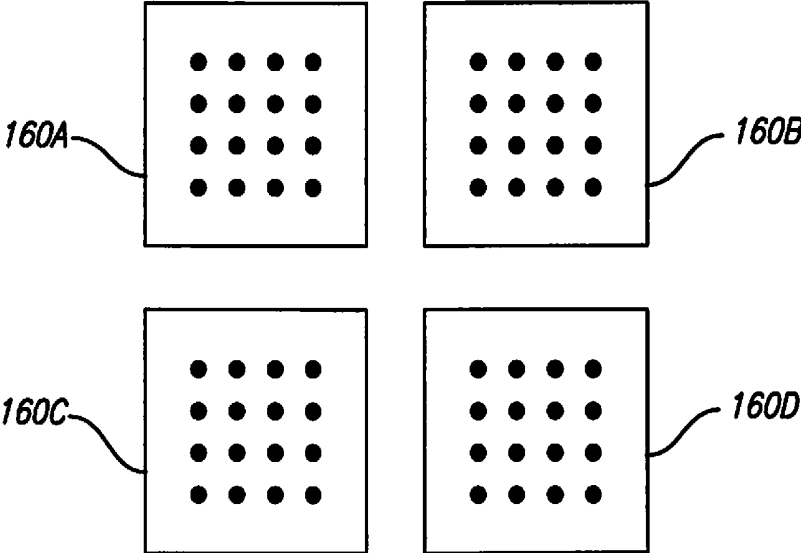
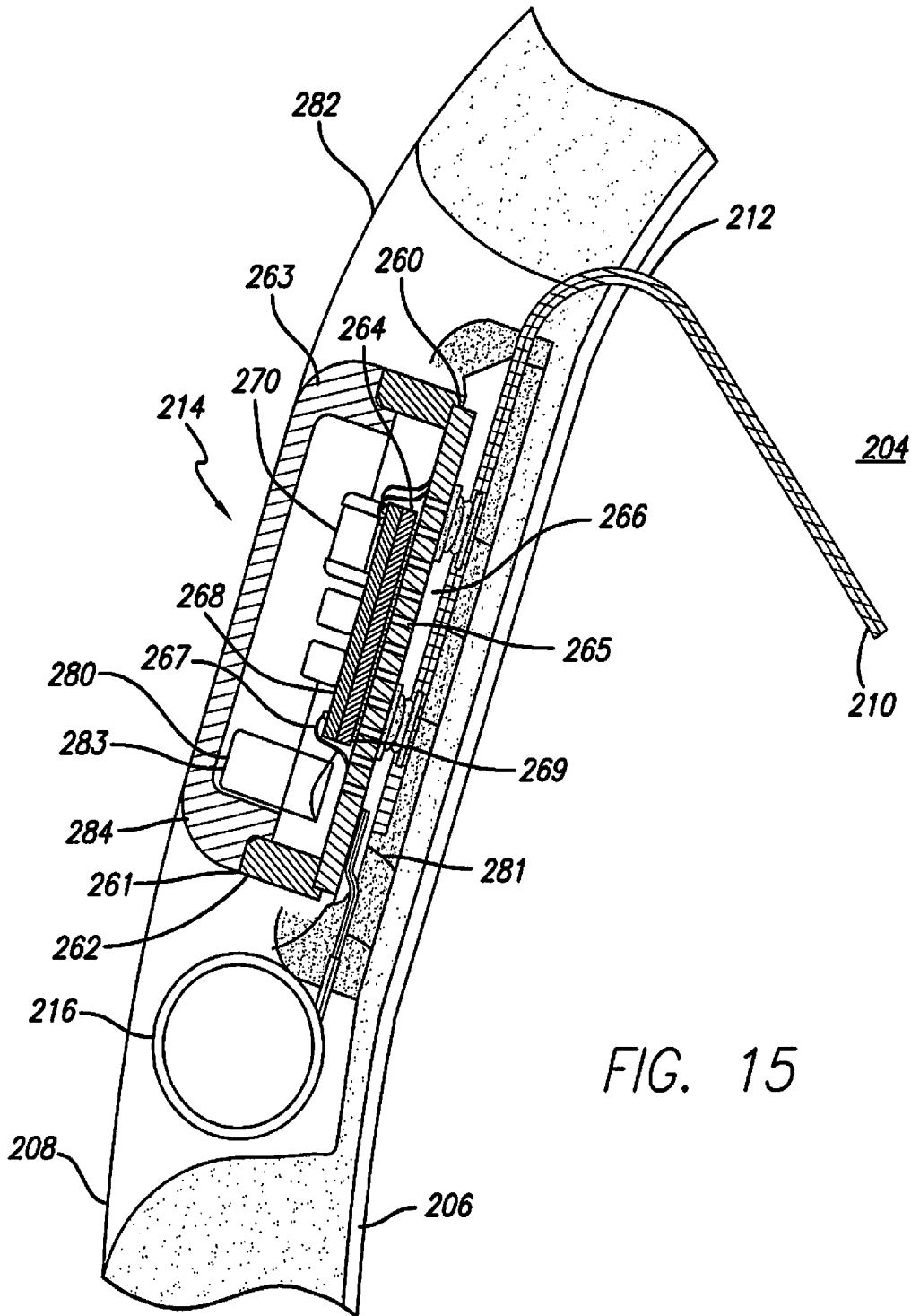

FIG. 14M



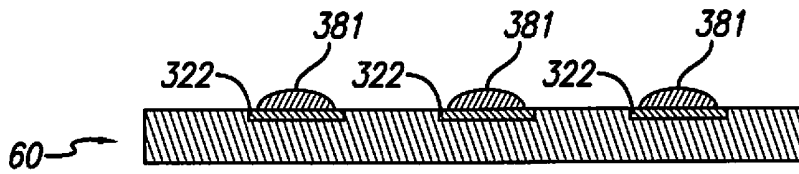

FIG. 16A

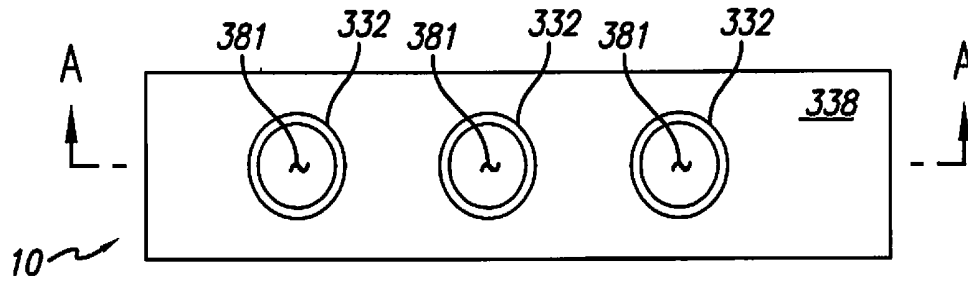

FIG. 16B

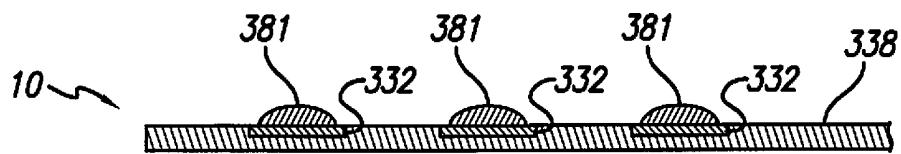

FIG. 16C

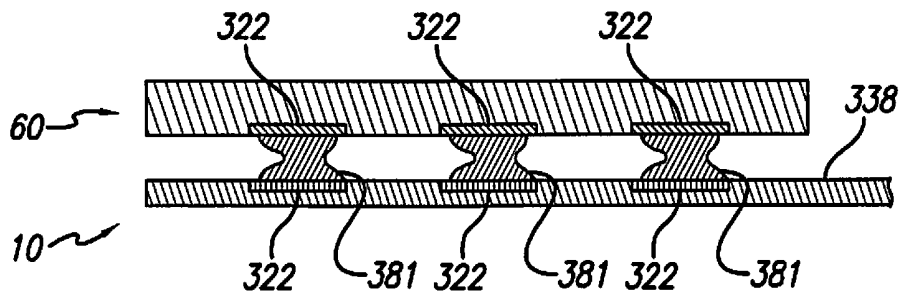

FIG. 16D

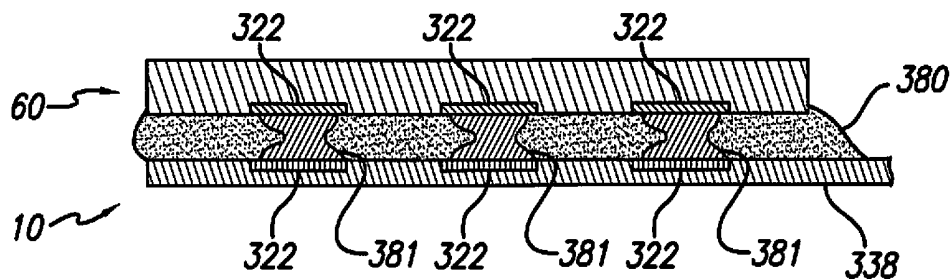

FIG. 16E

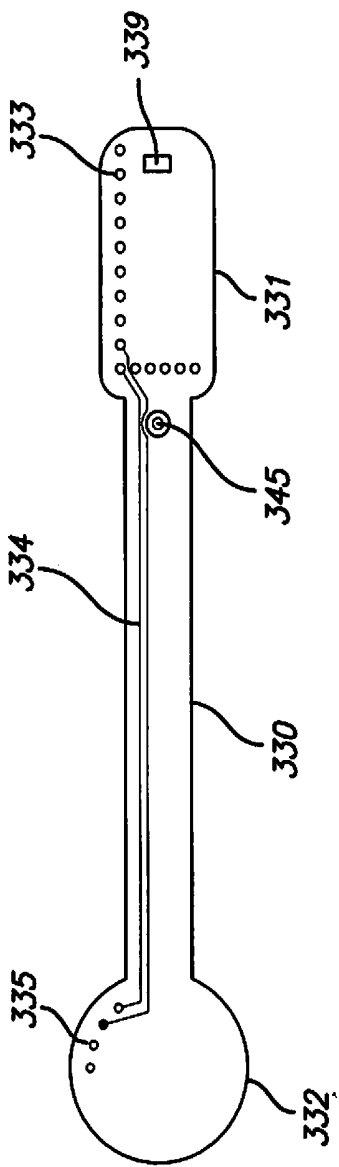

FIG. 17A

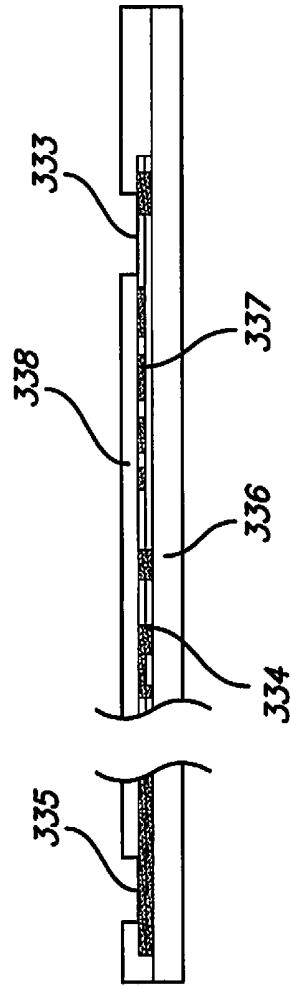

FIG. 17B

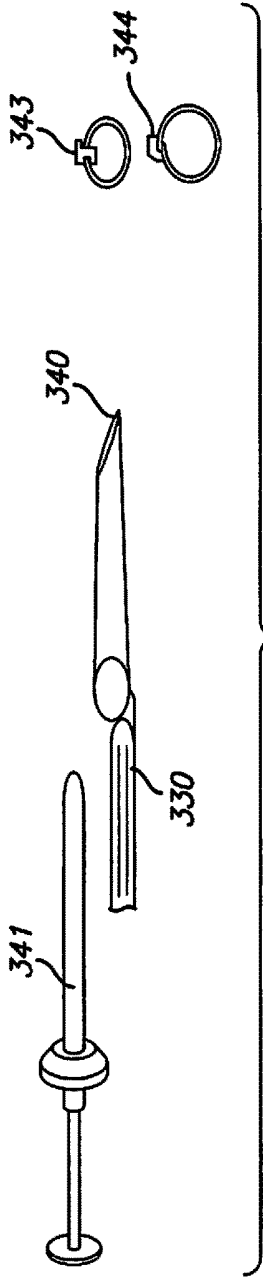

FIG. 18A

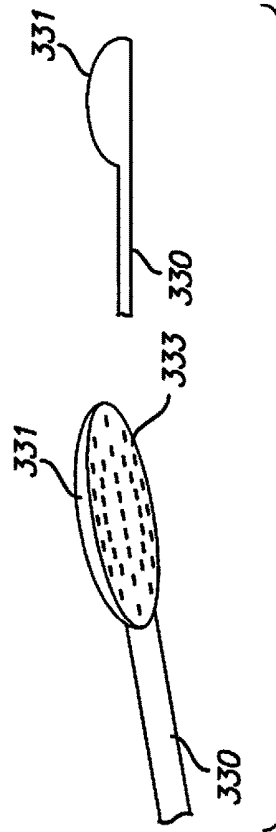

FIG. 18B

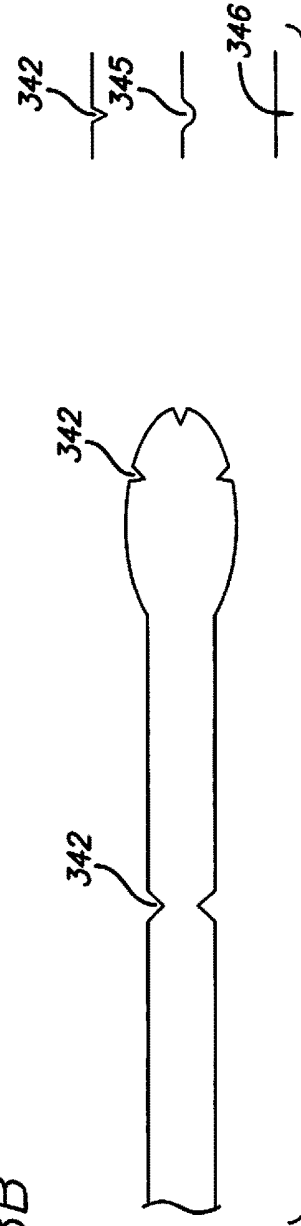

FIG. 18C

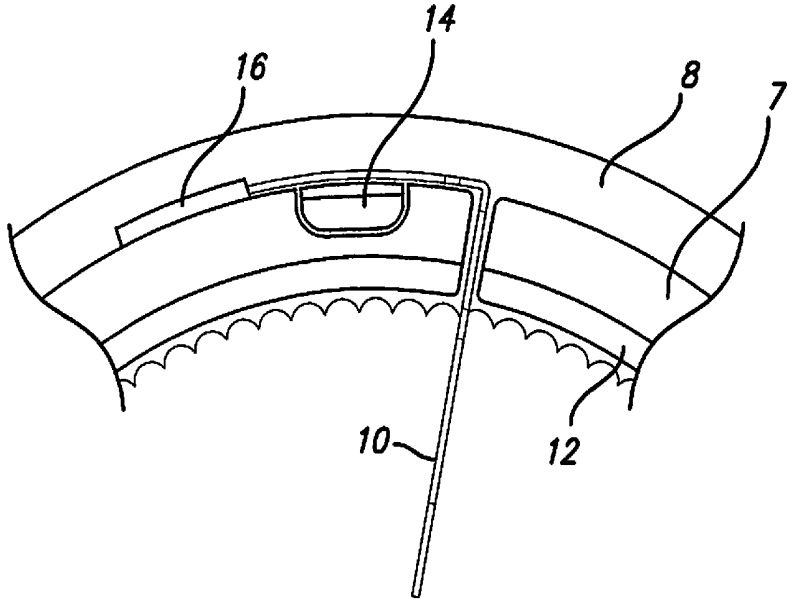

FIG. 19A

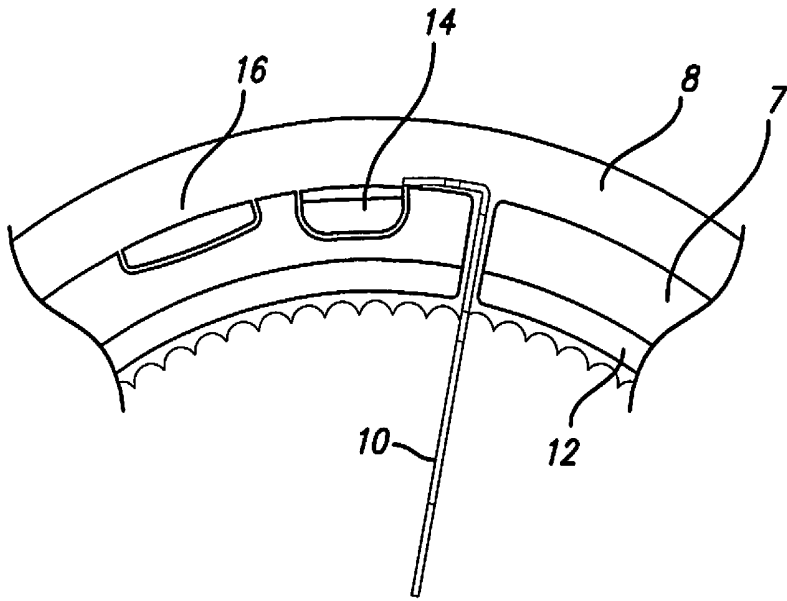
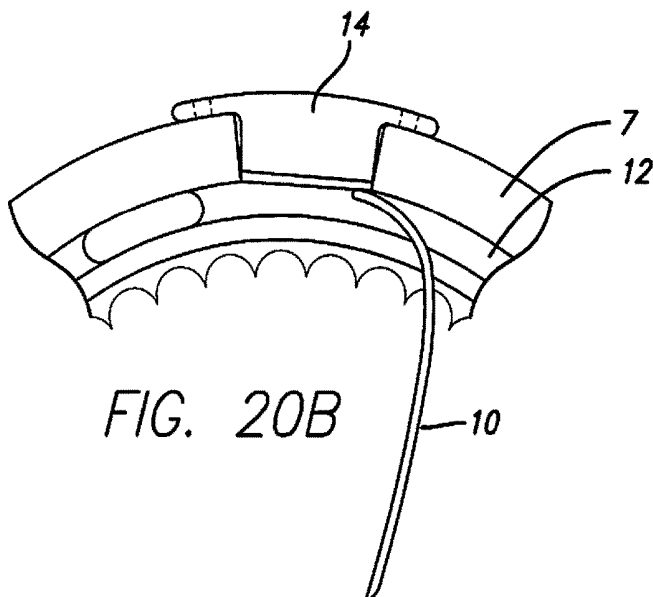
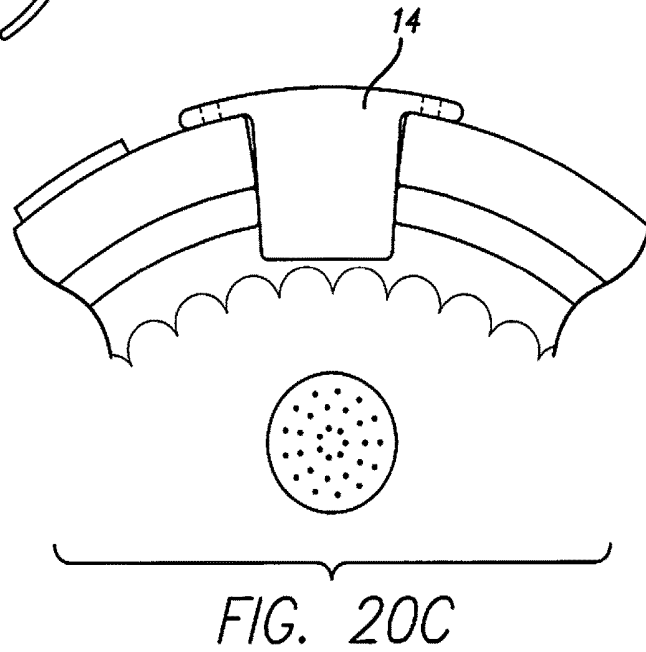
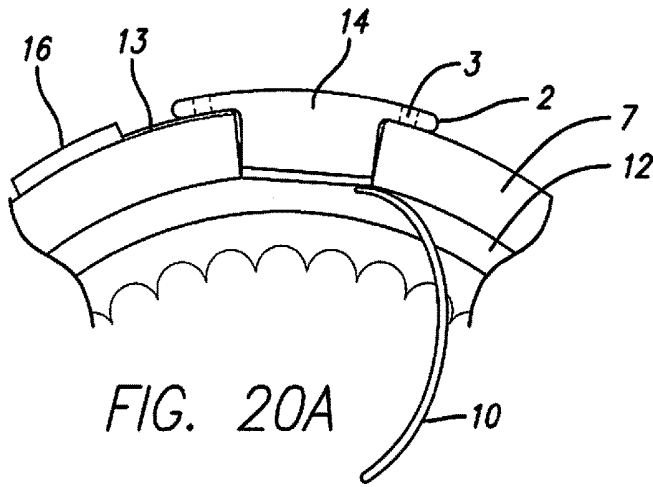

FIG. 19B



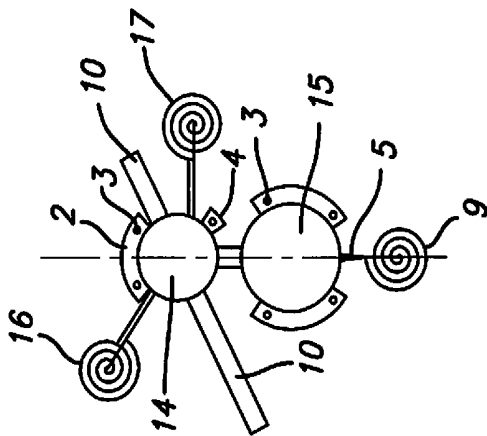

FIG. 21A

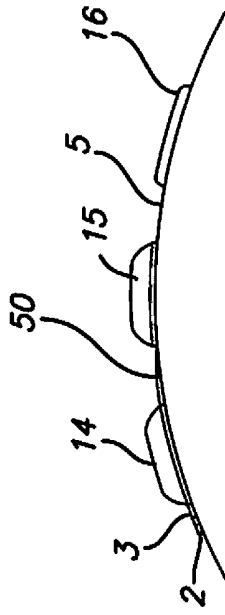

FIG. 21B

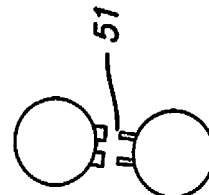

FIG. 21D

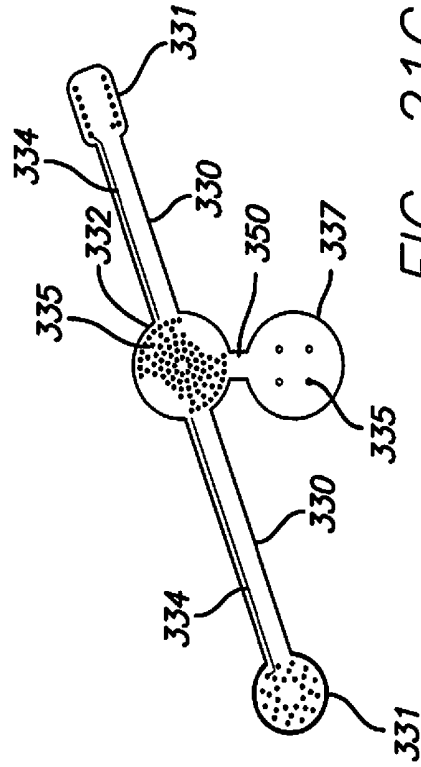

FIG. 21C

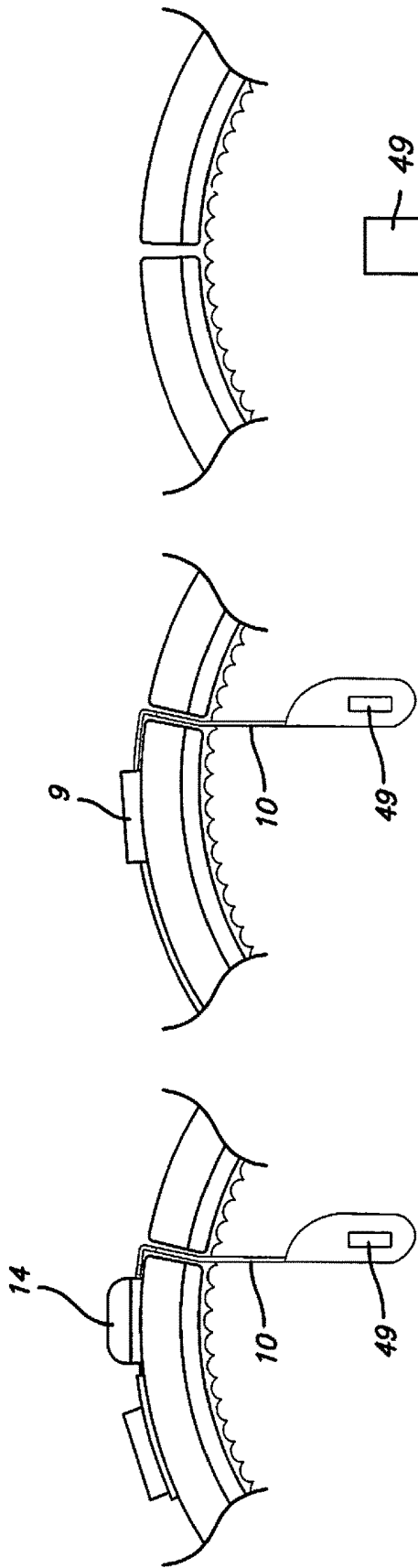

FIG. 22A

FIG. 22B

FIG. 22C



FIG. 22D

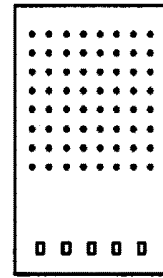

FIG. 22E

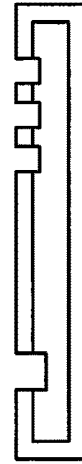

FIG. 22F

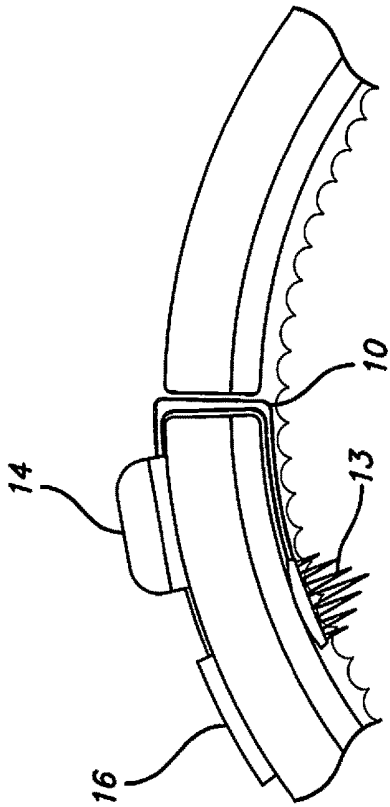

FIG. 23B

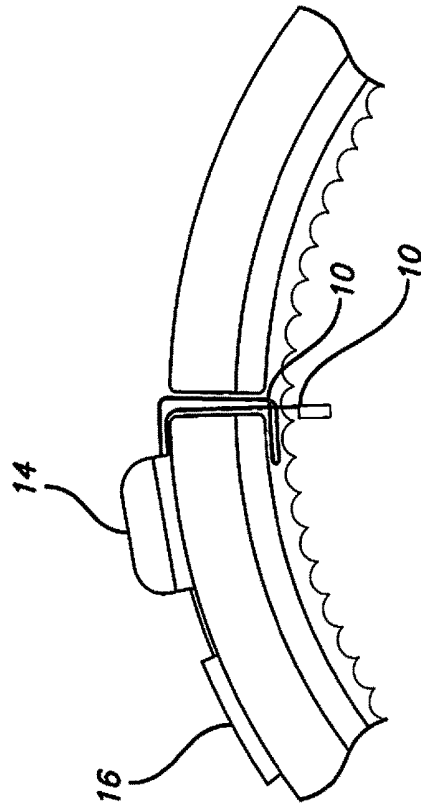

FIG. 23C

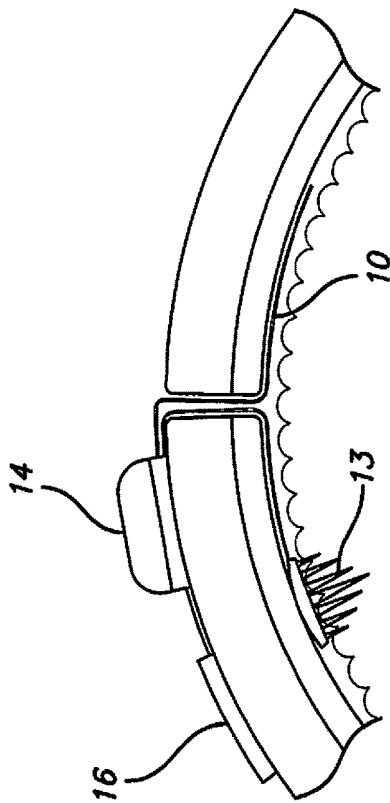

FIG. 23A

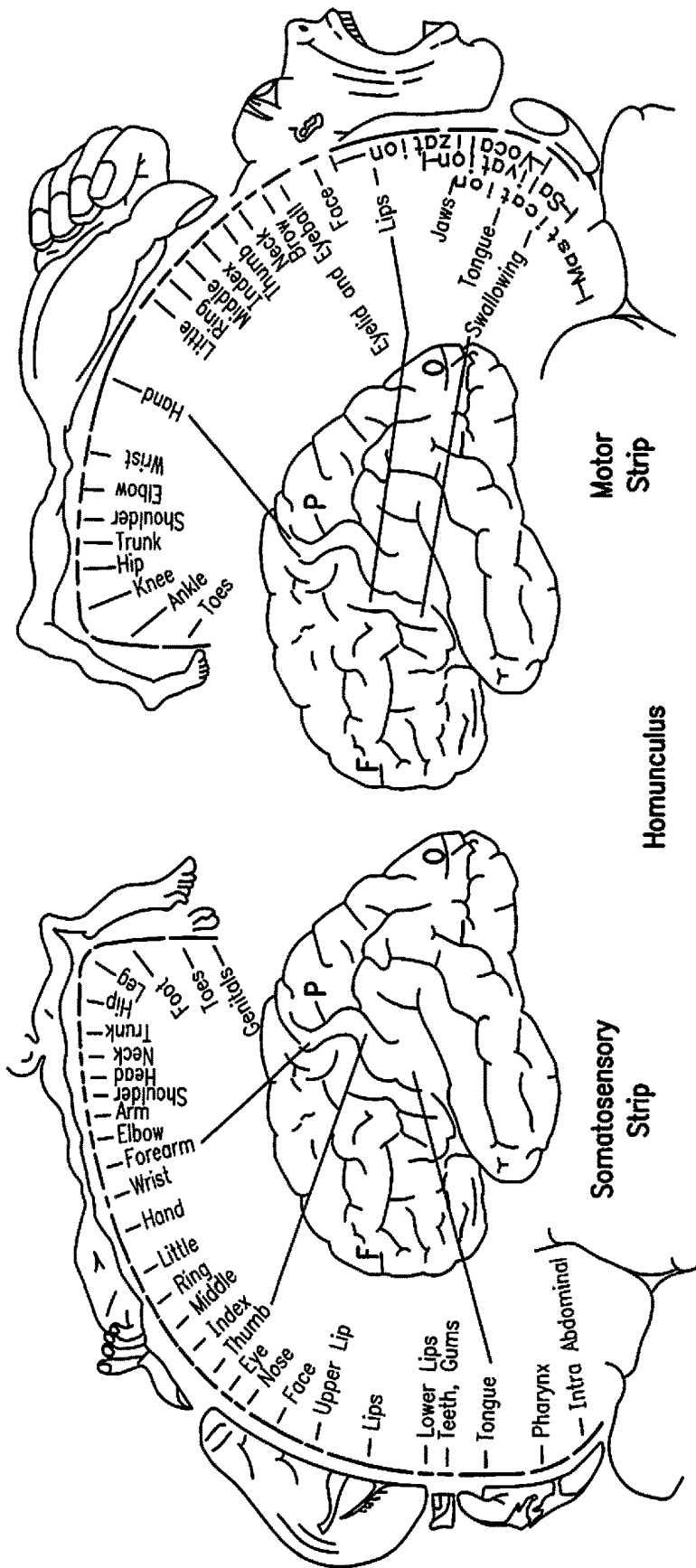

FIG. 24

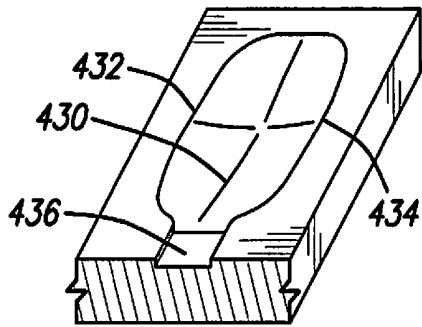

FIG. 25A

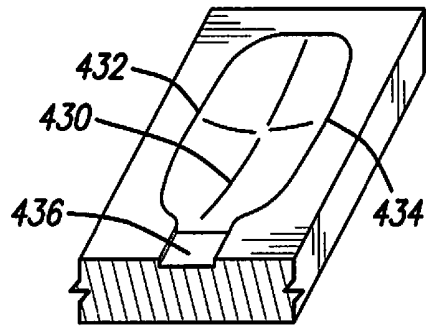

FIG. 25B

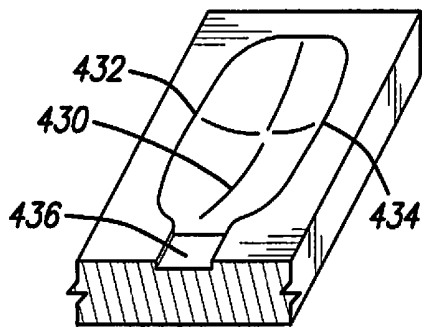

FIG. 25C

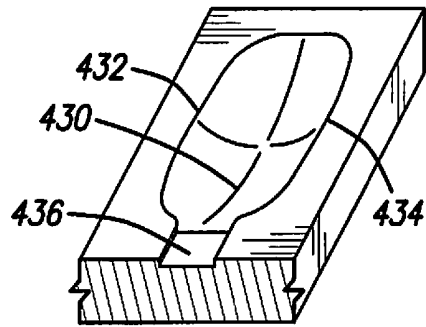

FIG. 25D

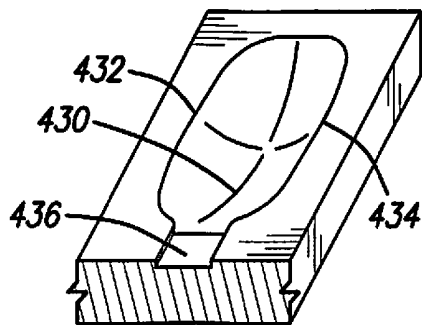

FIG. 25E

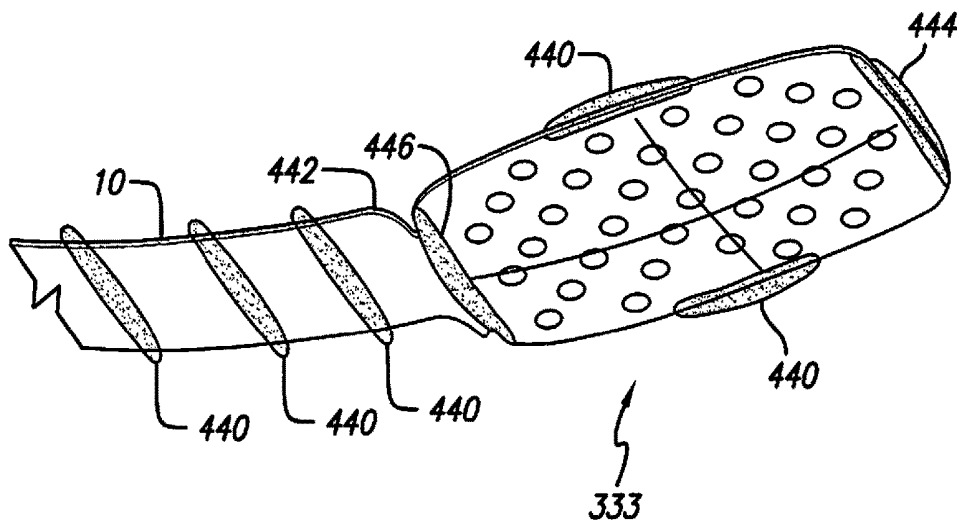

FIG. 26

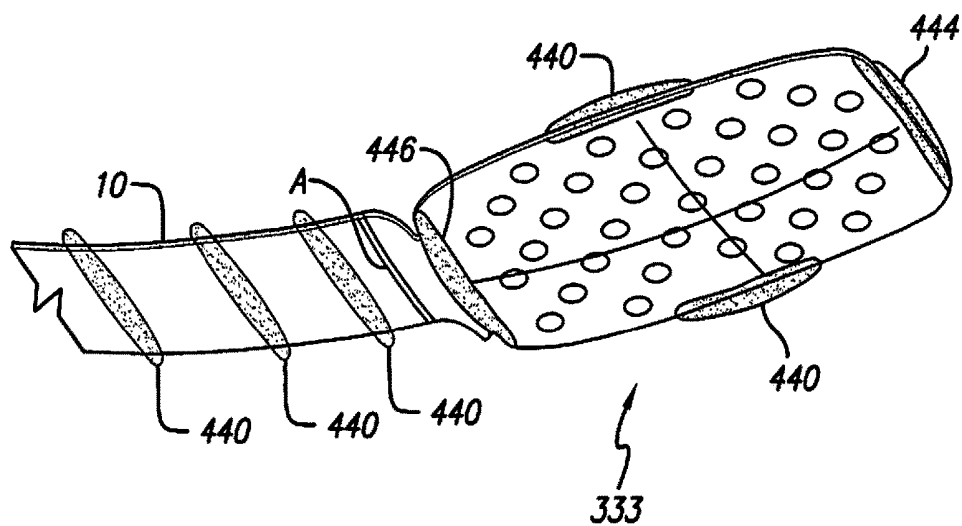

FIG. 27

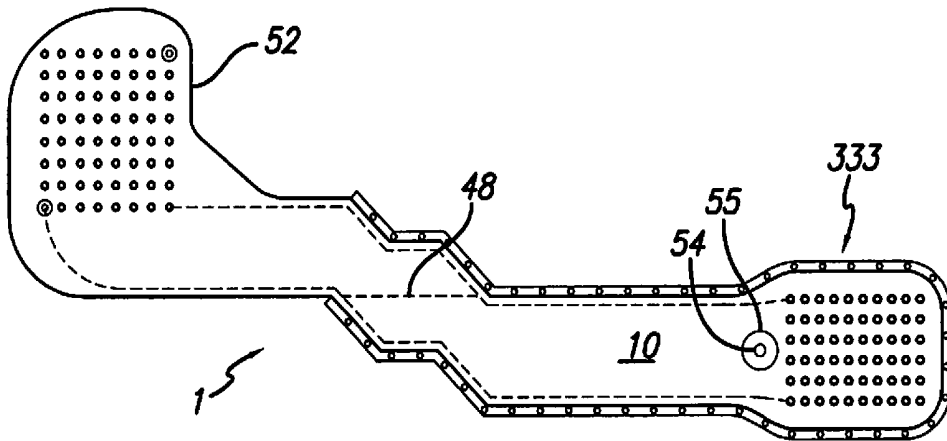

FIG. 28

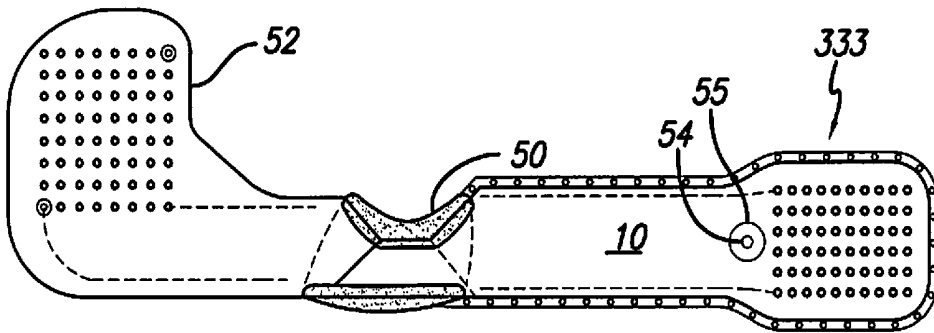

FIG. 29

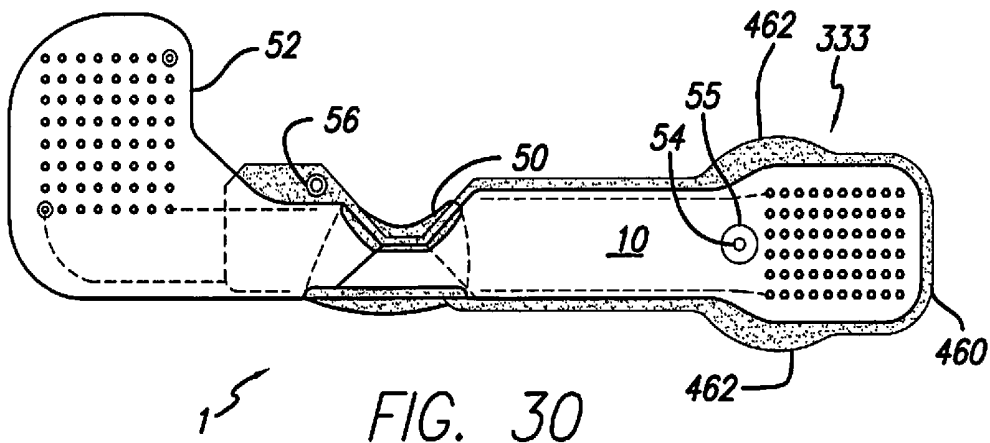

FIG. 30

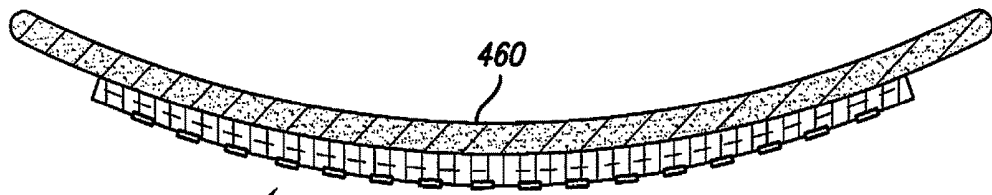

FIG. 31

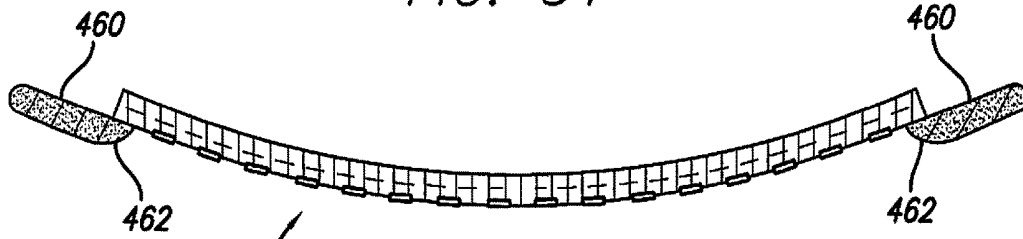

FIG. 32

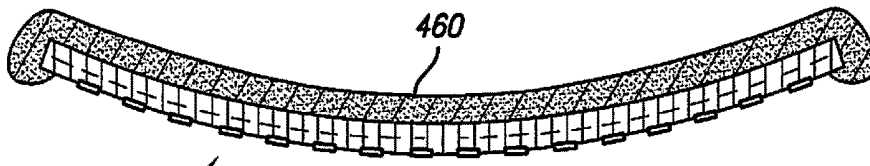

FIG. 33

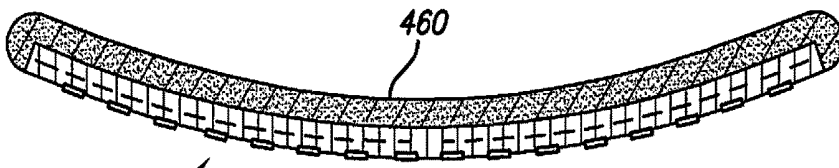

FIG. 34

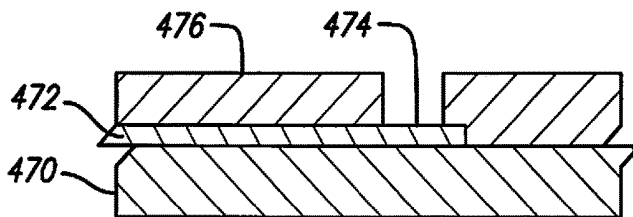

FIG. 35

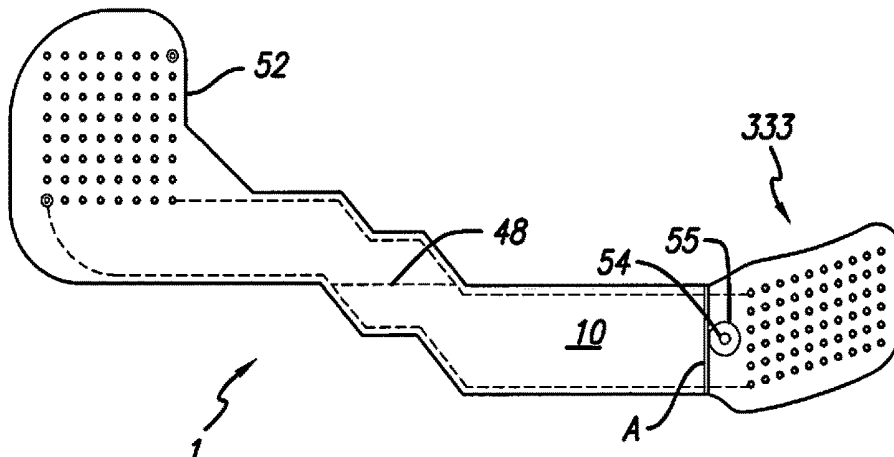

FIG. 36

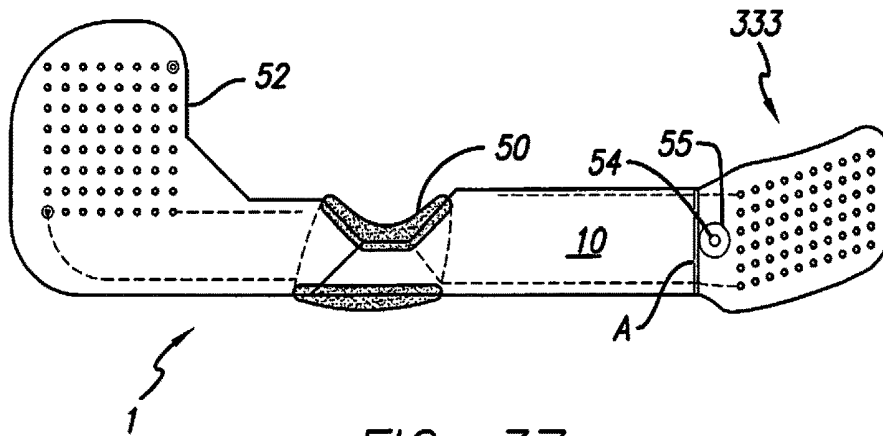

FIG. 37

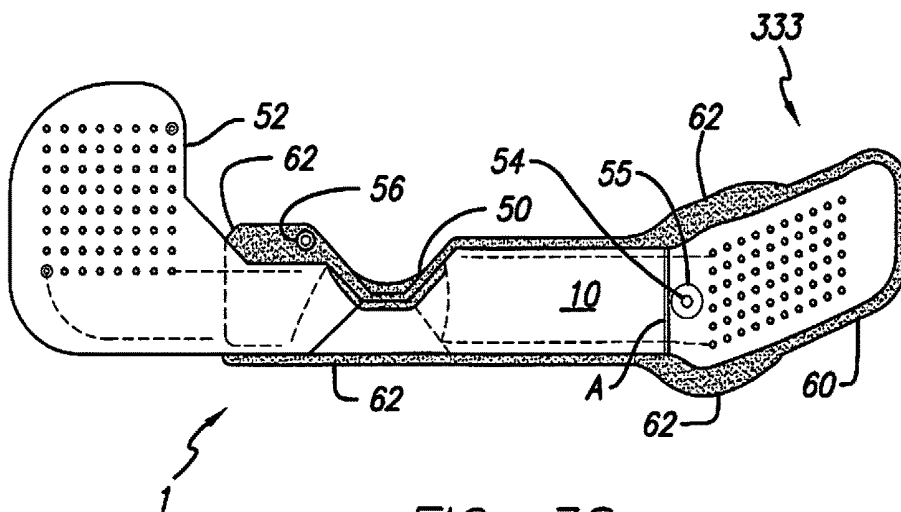

FIG. 38

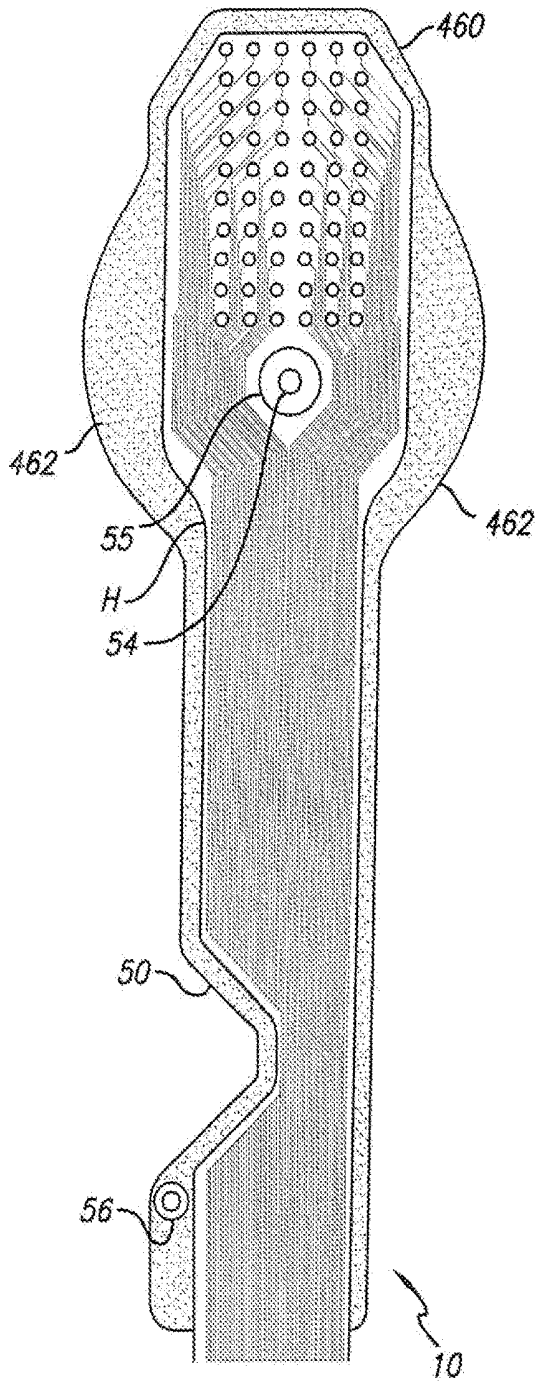
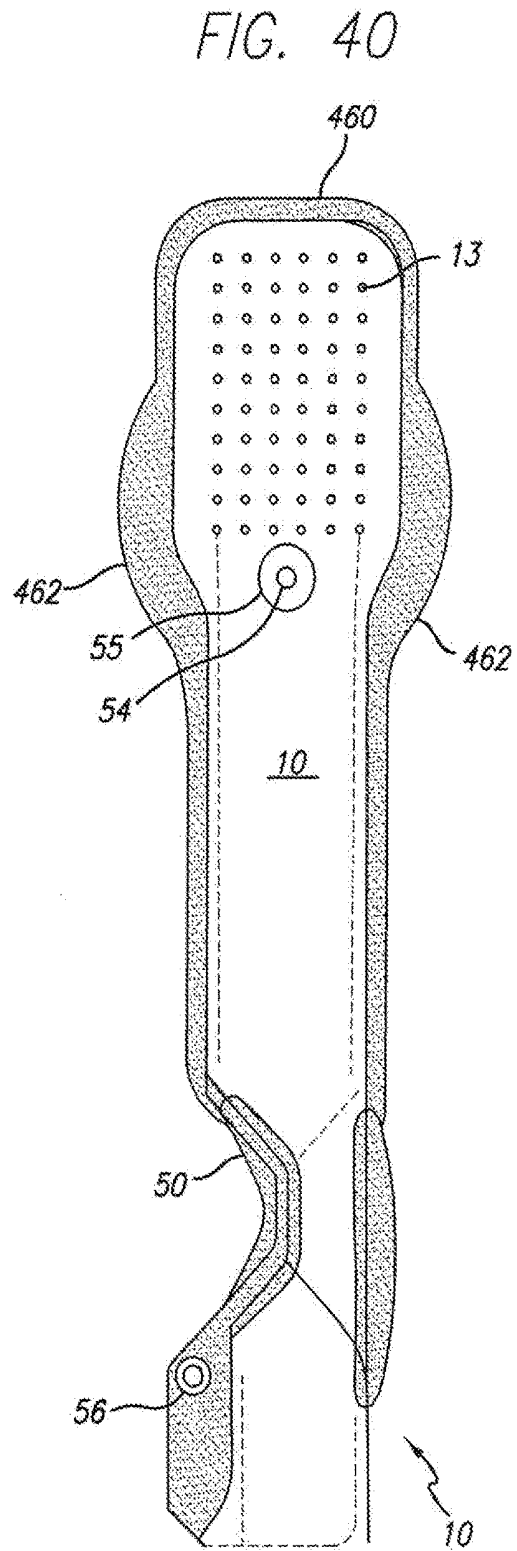

FIG. 39



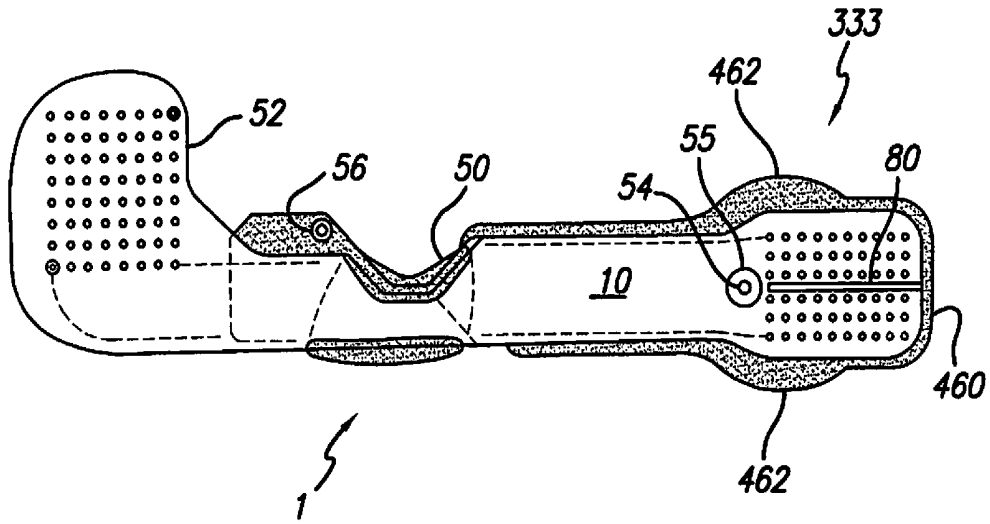

FIG. 41

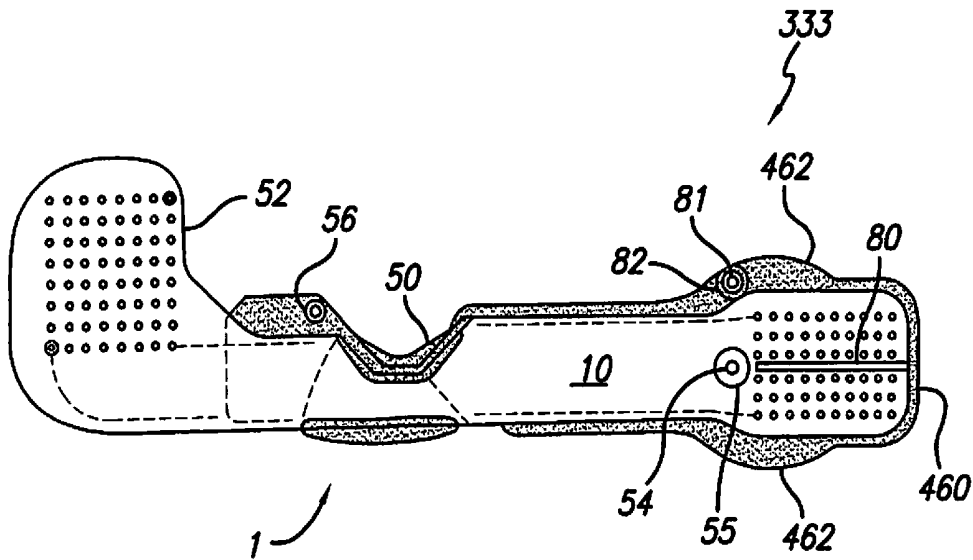
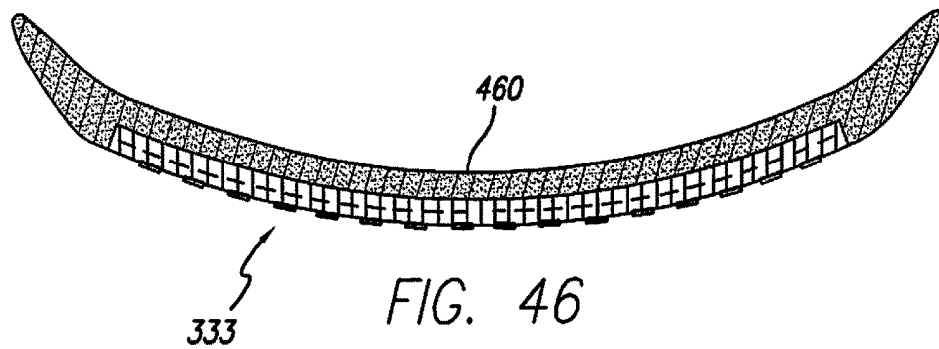
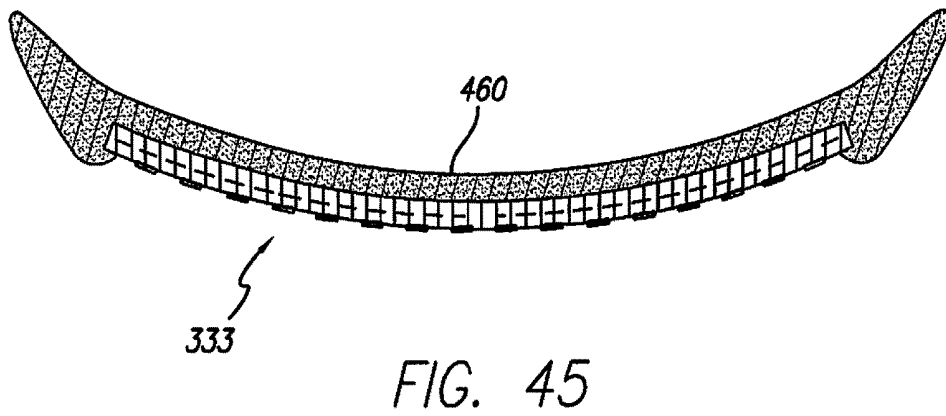
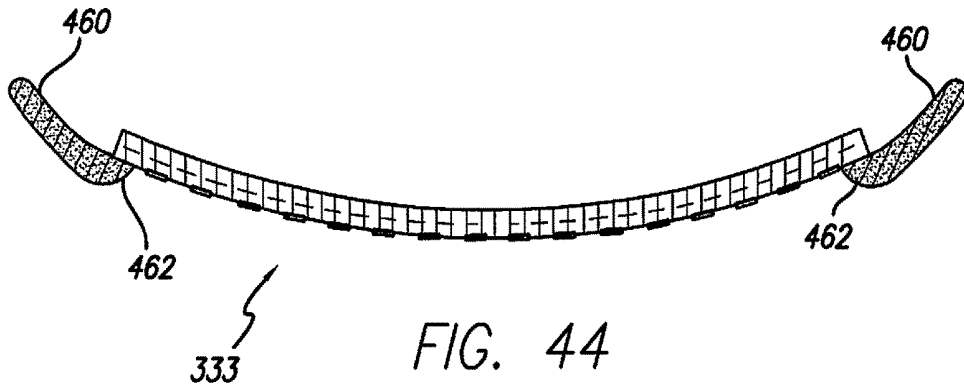
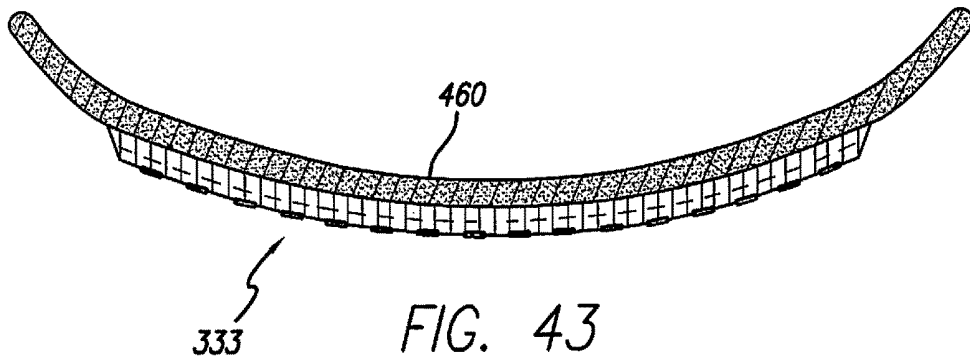
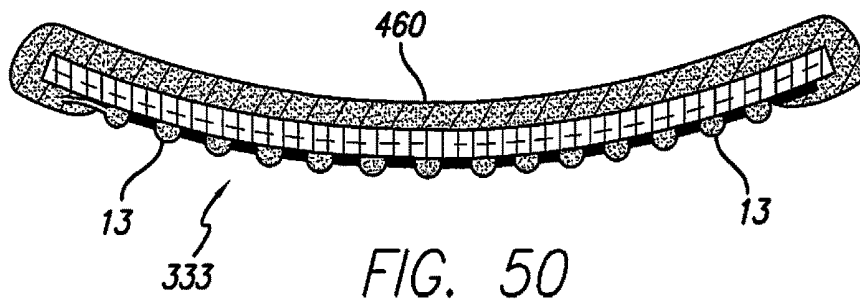
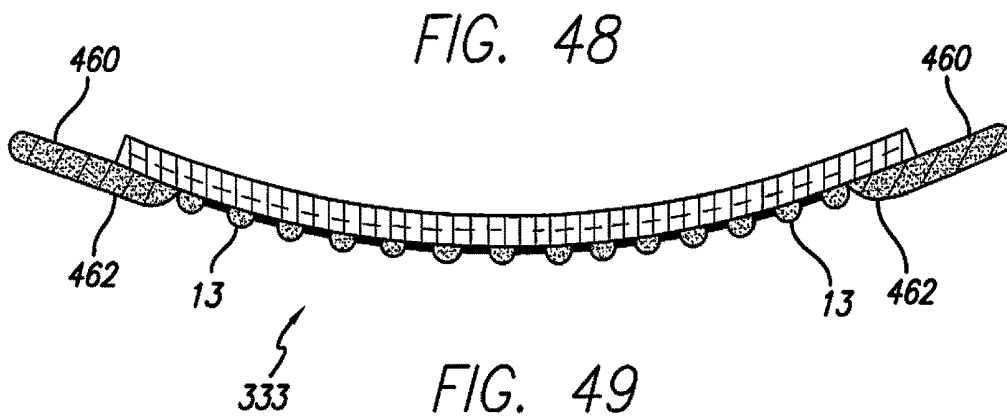
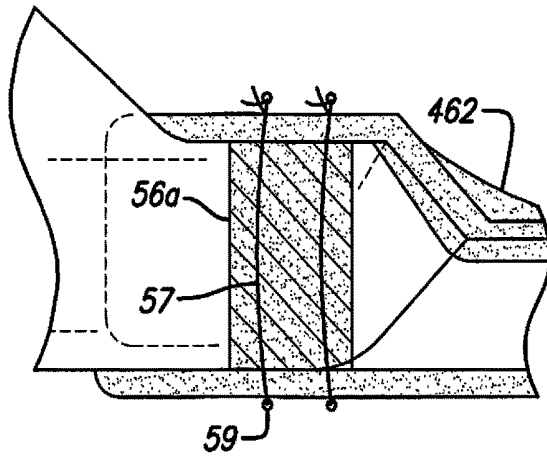
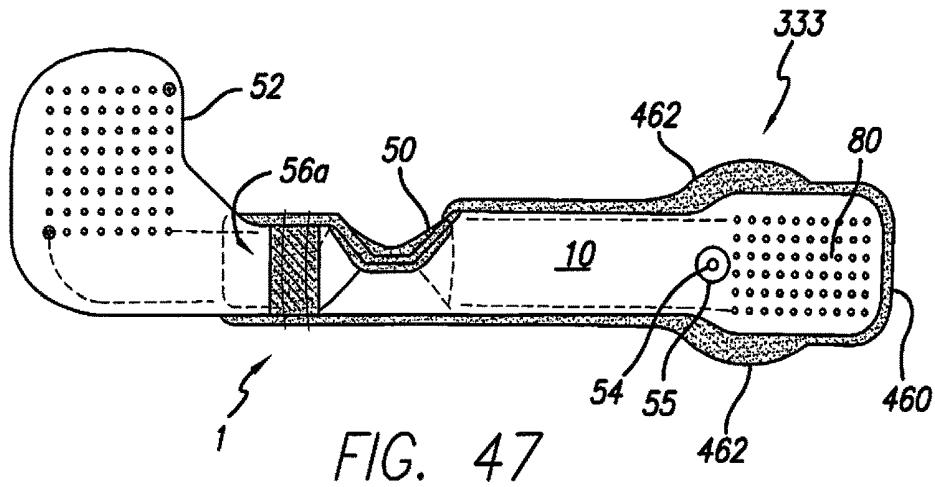

FIG. 42





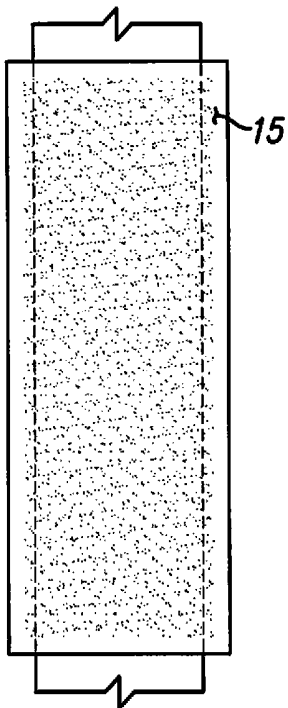

FIG. 51

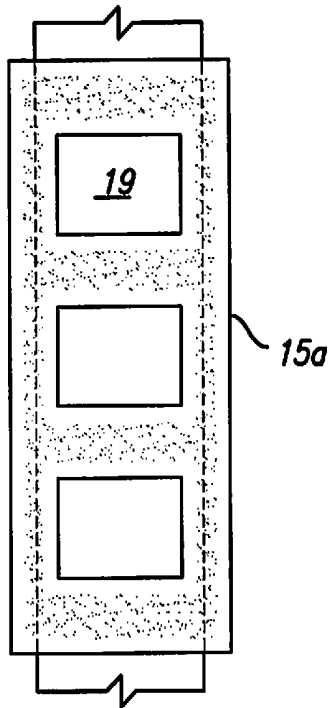

FIG. 52

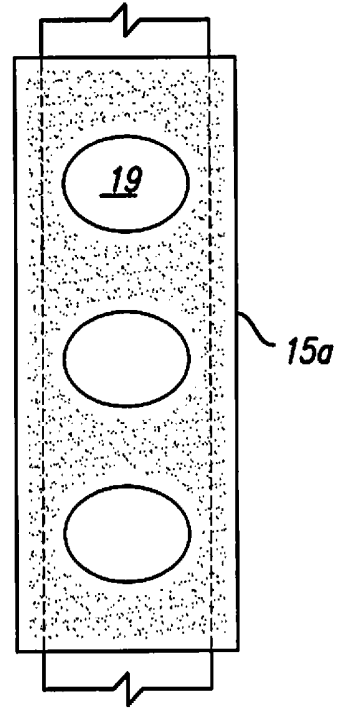

FIG. 53

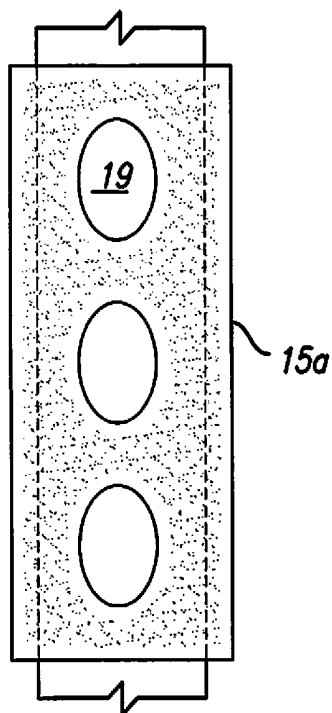

FIG. 54

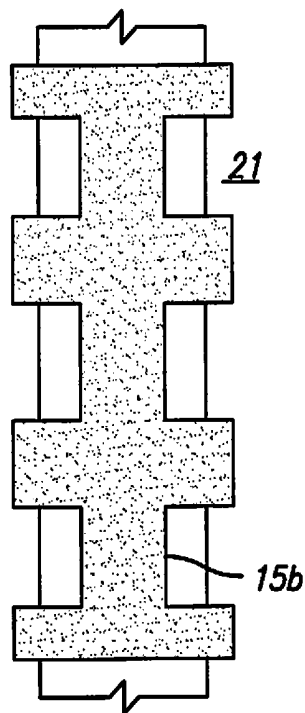

FIG. 55

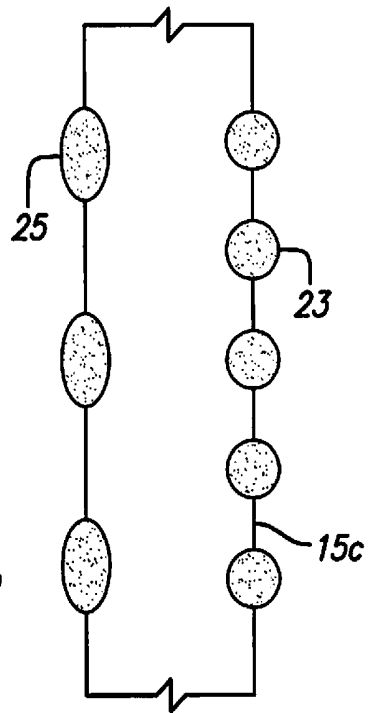
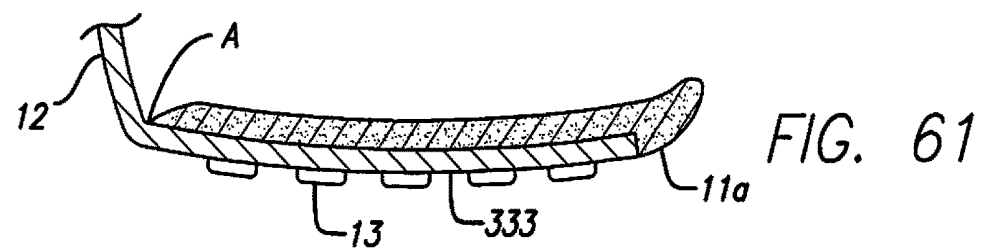
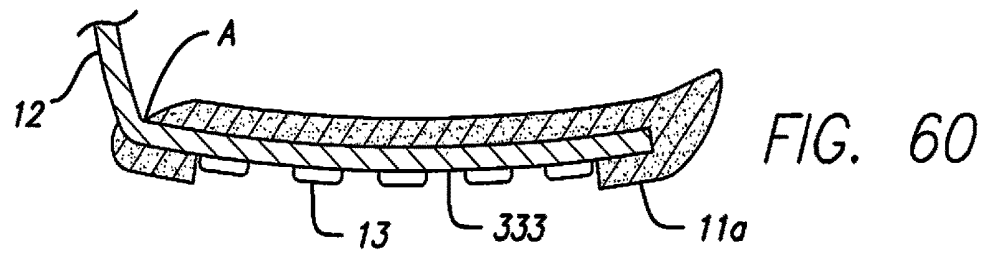
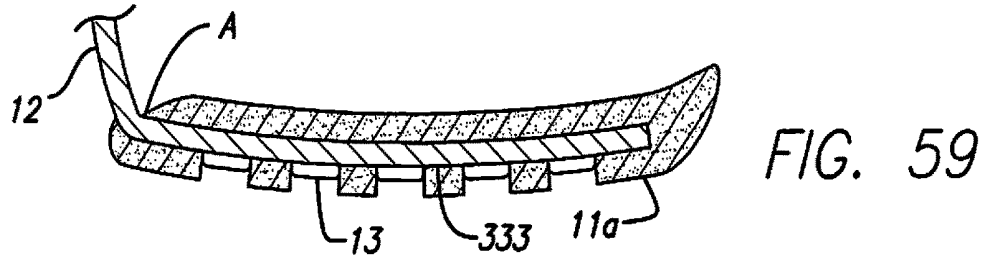
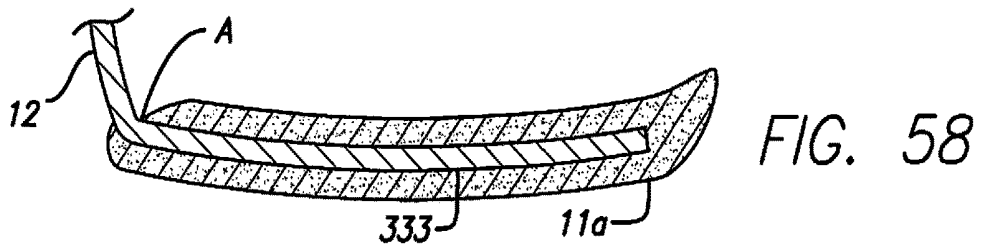
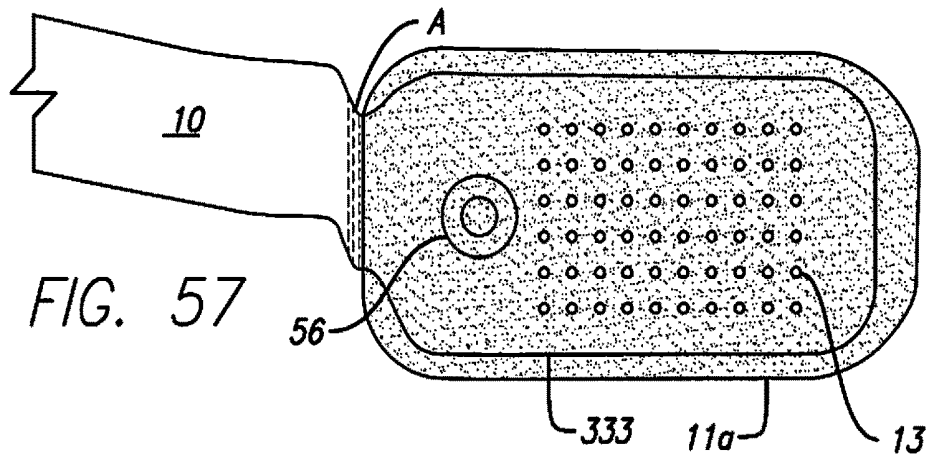

FIG. 56



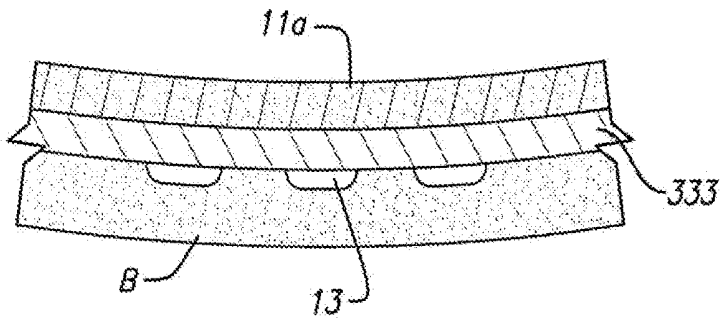

FIG. 62

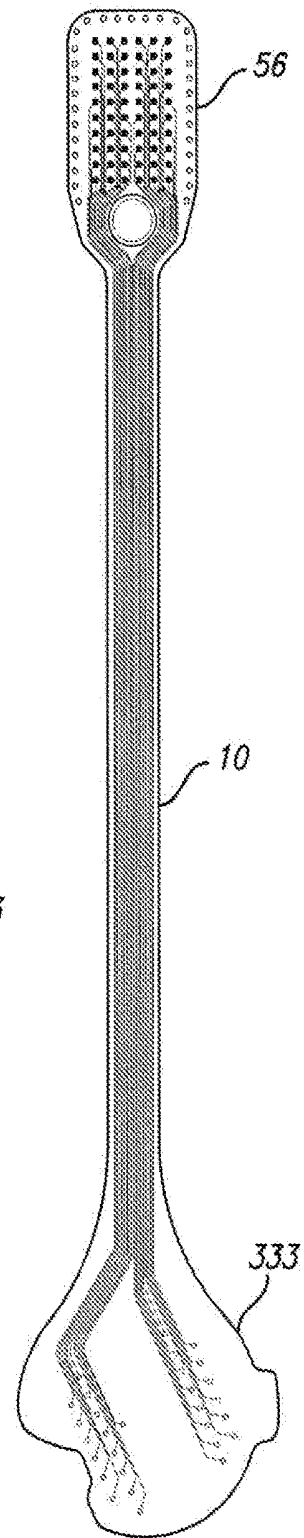

FIG. 63

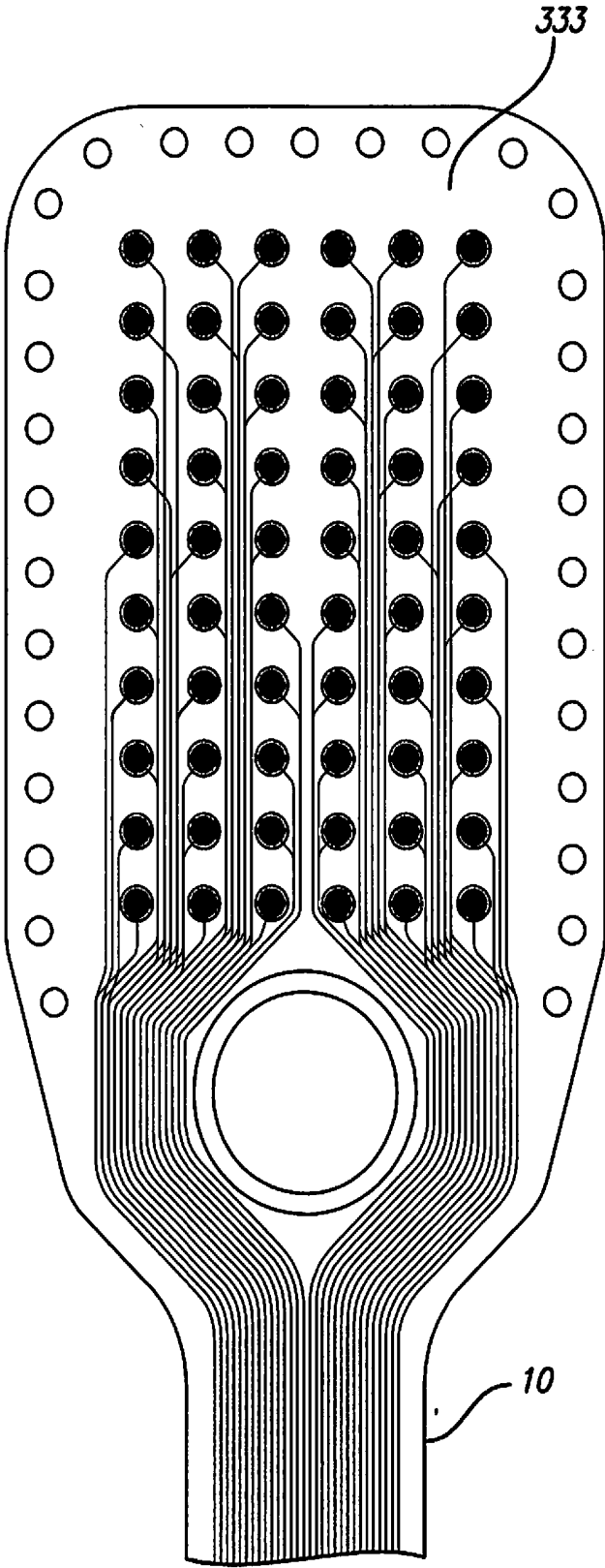

FIG. 64

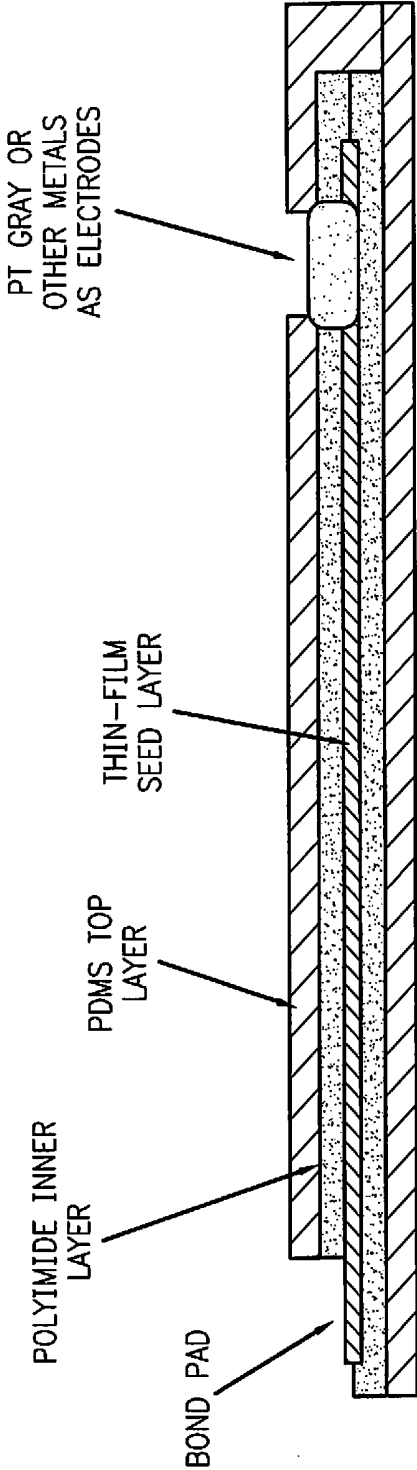

FIG. 65

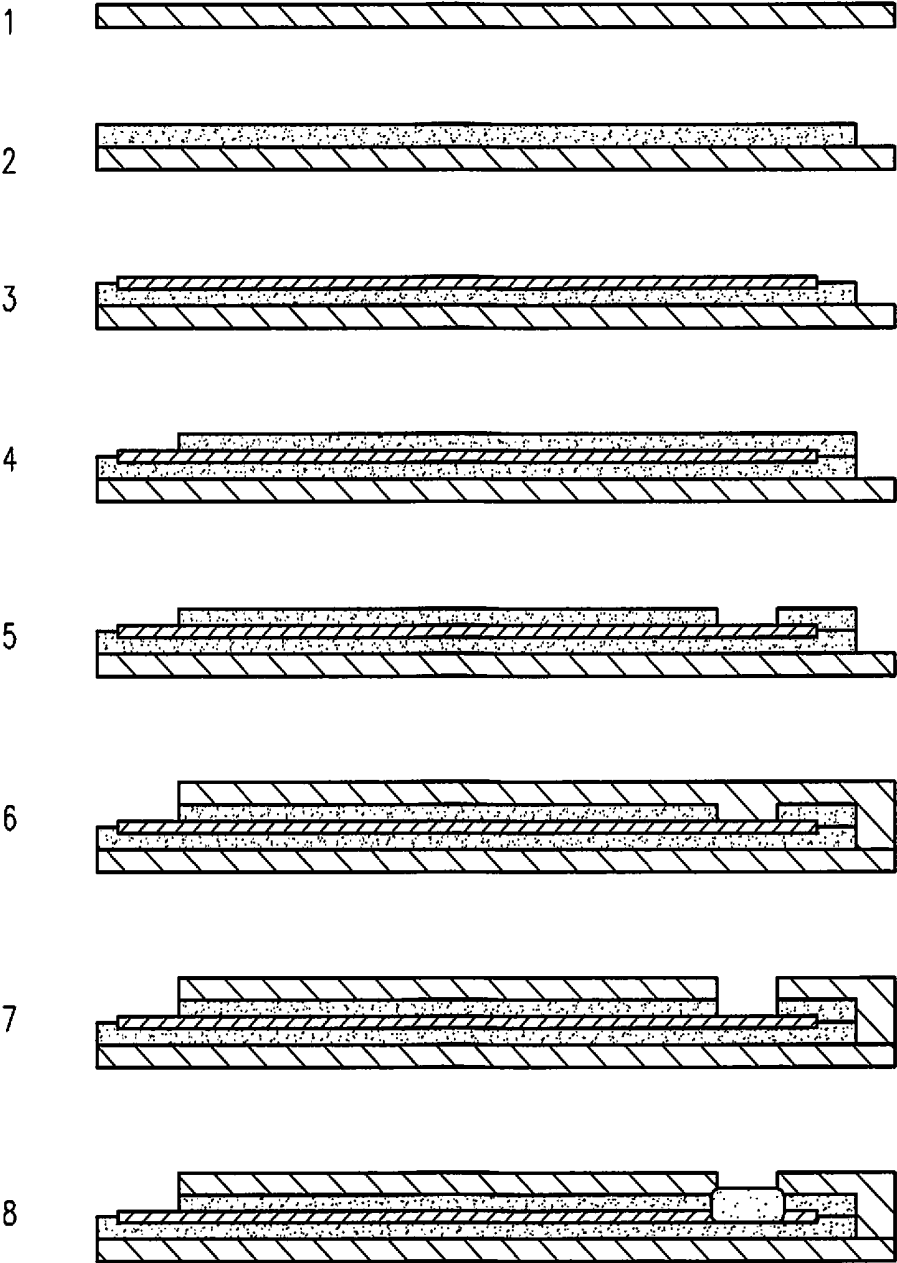

FIG. 66

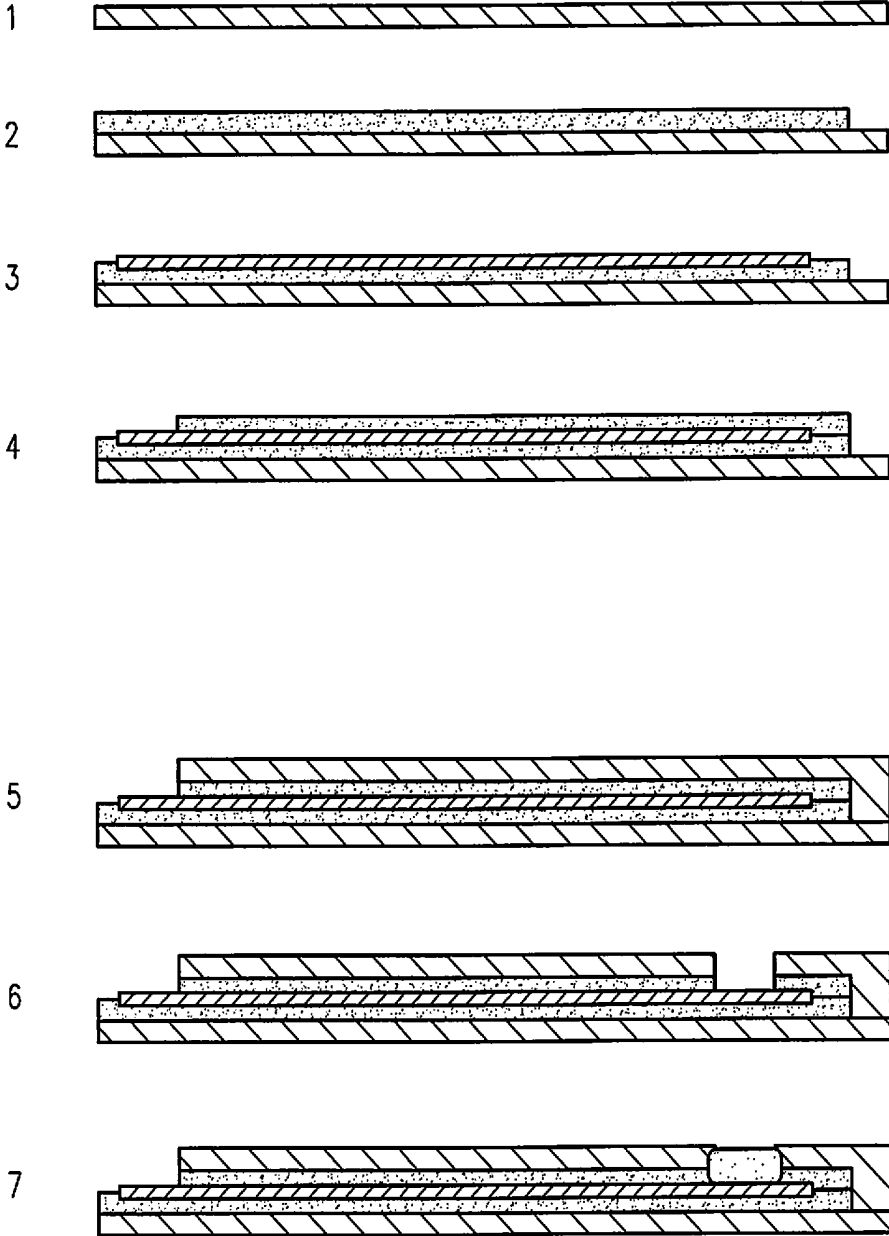

FIG. 67

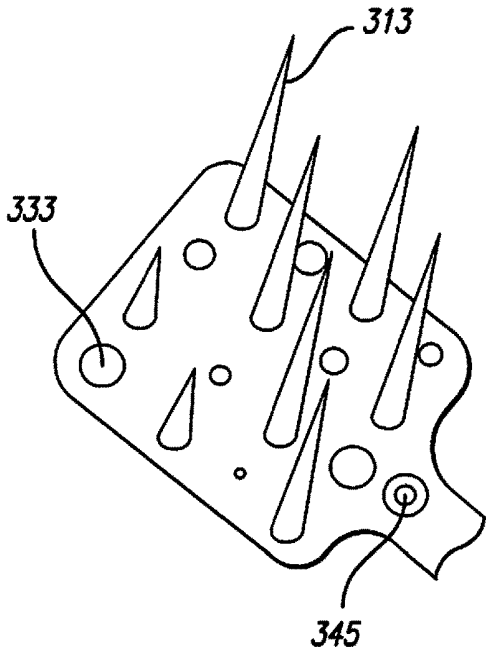

FIG. 68A

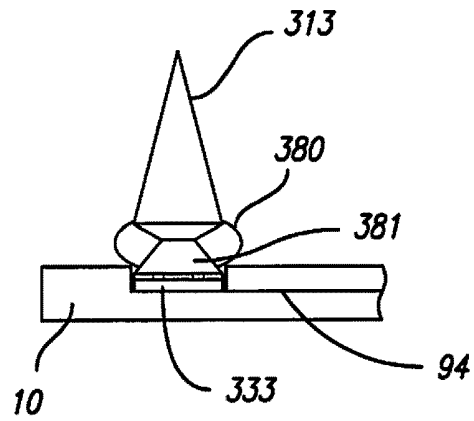

FIG. 68B

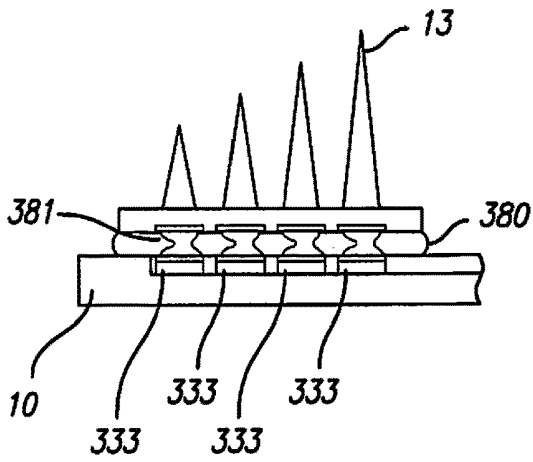

FIG. 68C

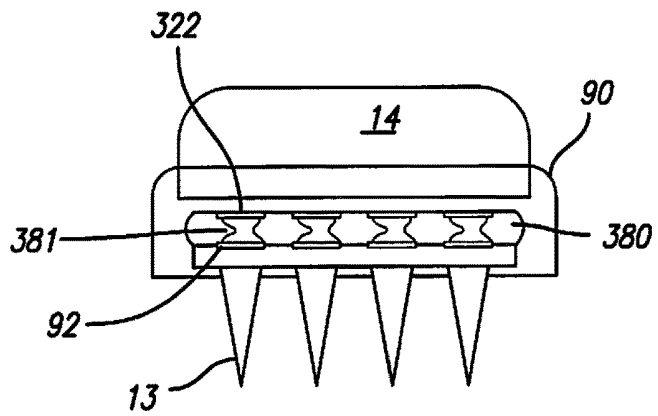

FIG. 68D

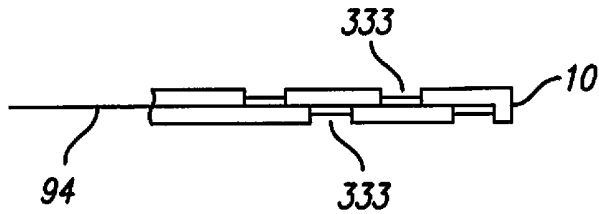

FIG. 69A

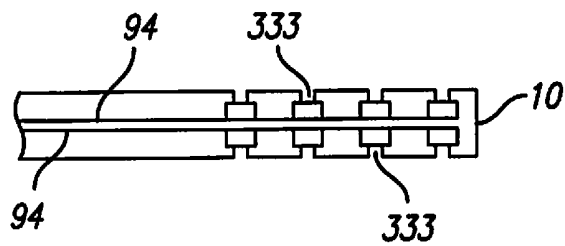

FIG. 69B

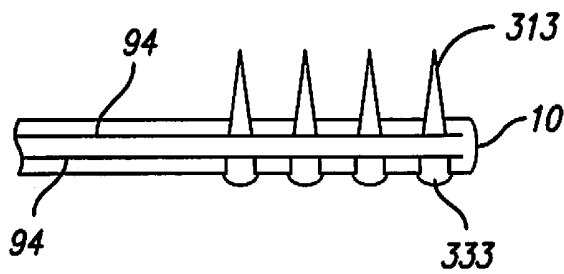

FIG. 69C

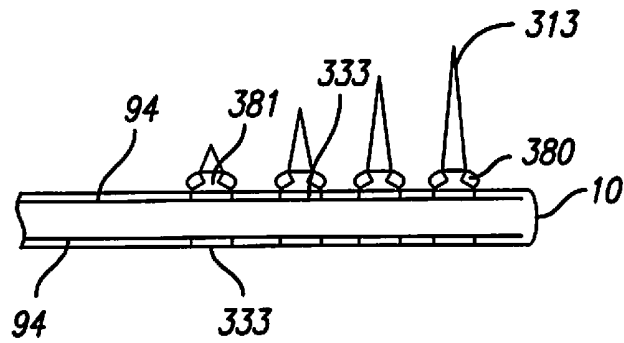

FIG. 69D

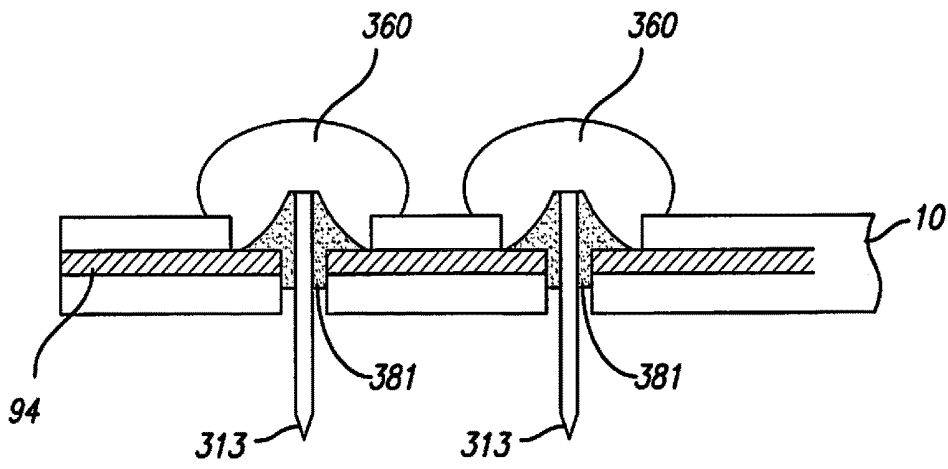

FIG. 70A

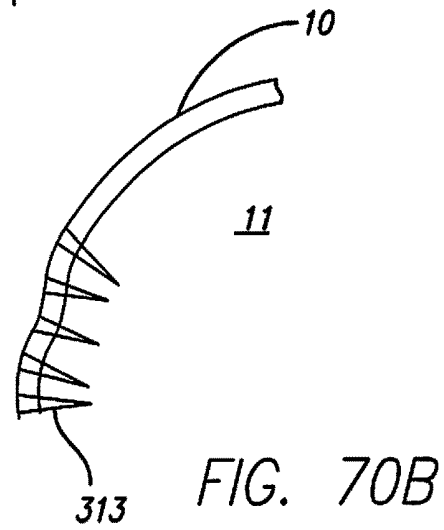

FIG. 70B

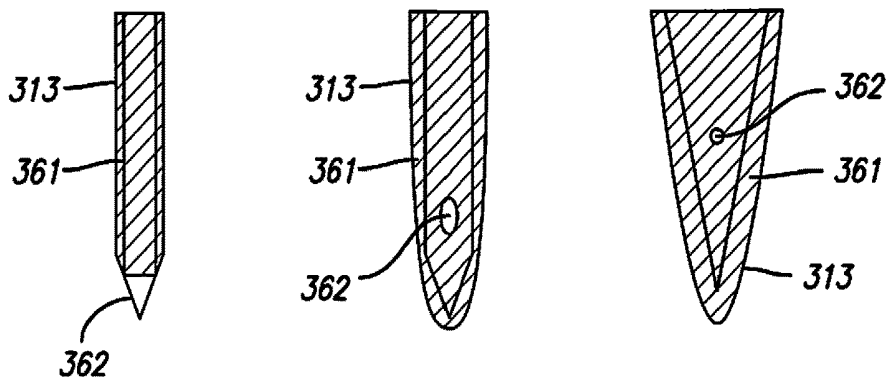

FIG. 70C

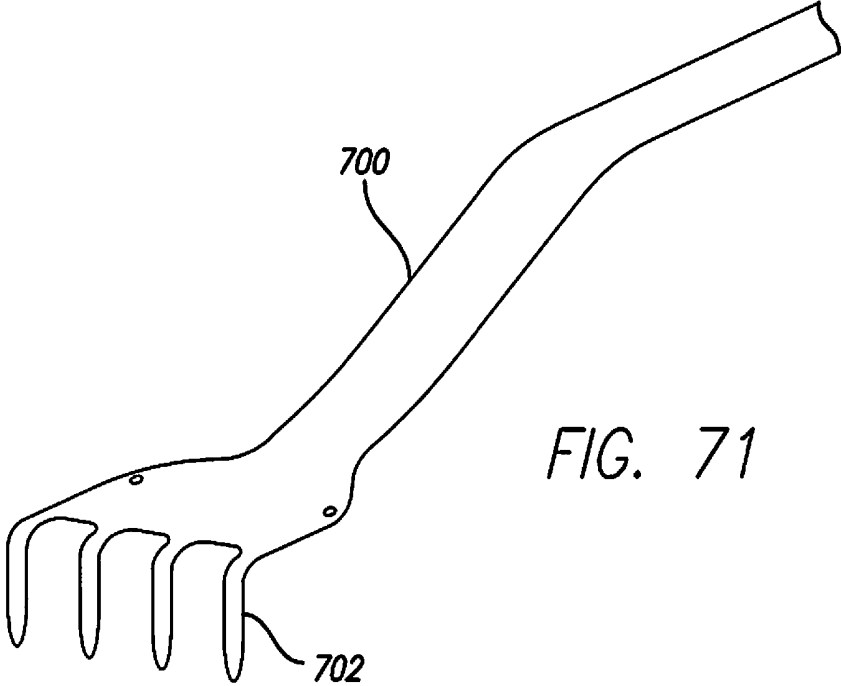

FIG. 71

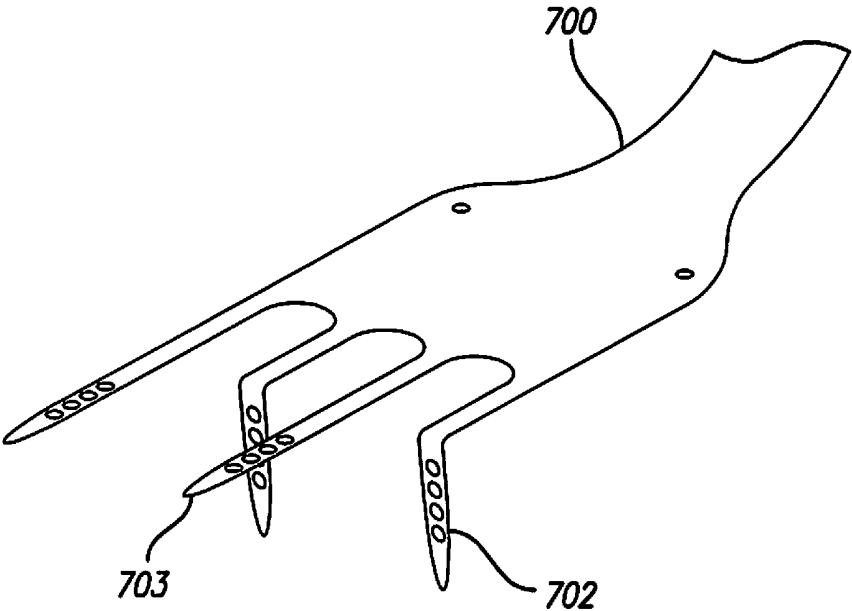

FIG. 72

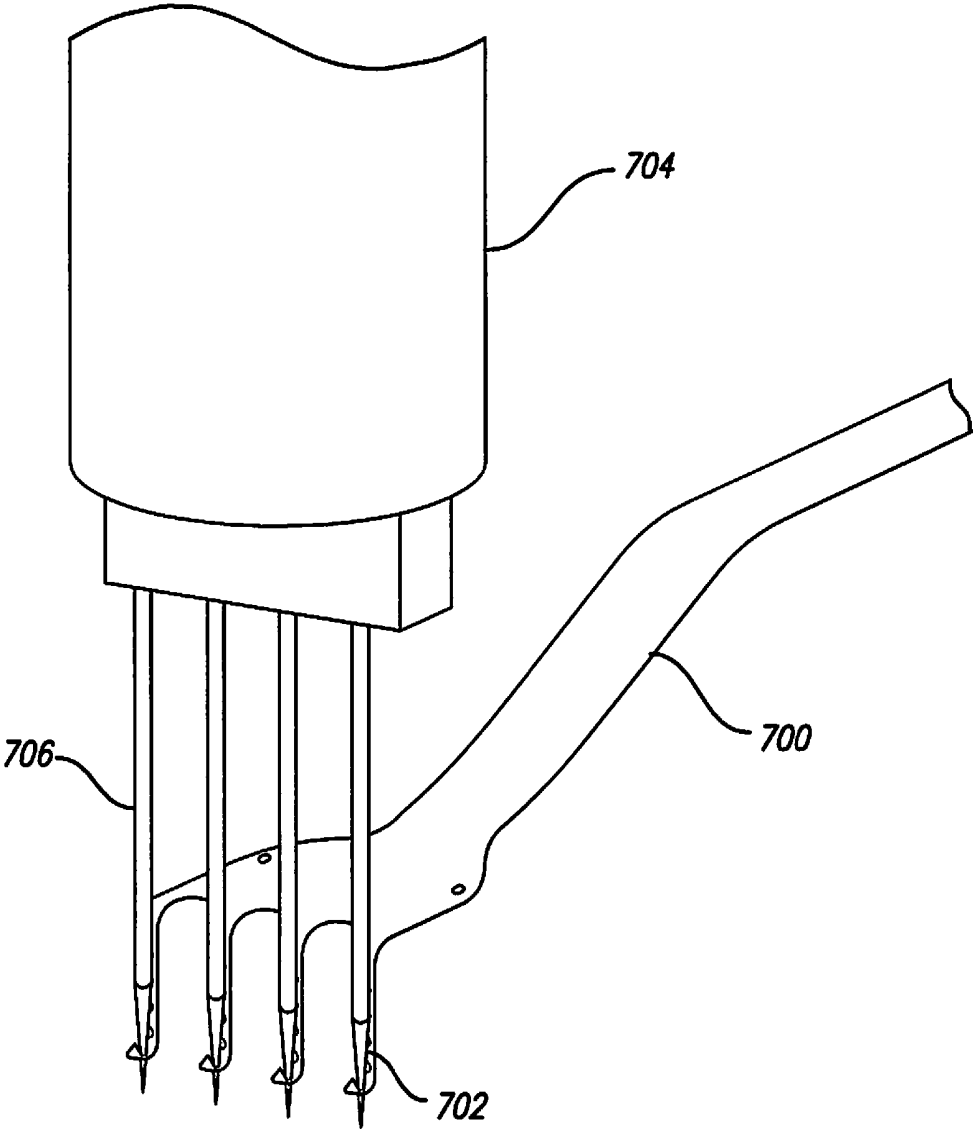

FIG. 73

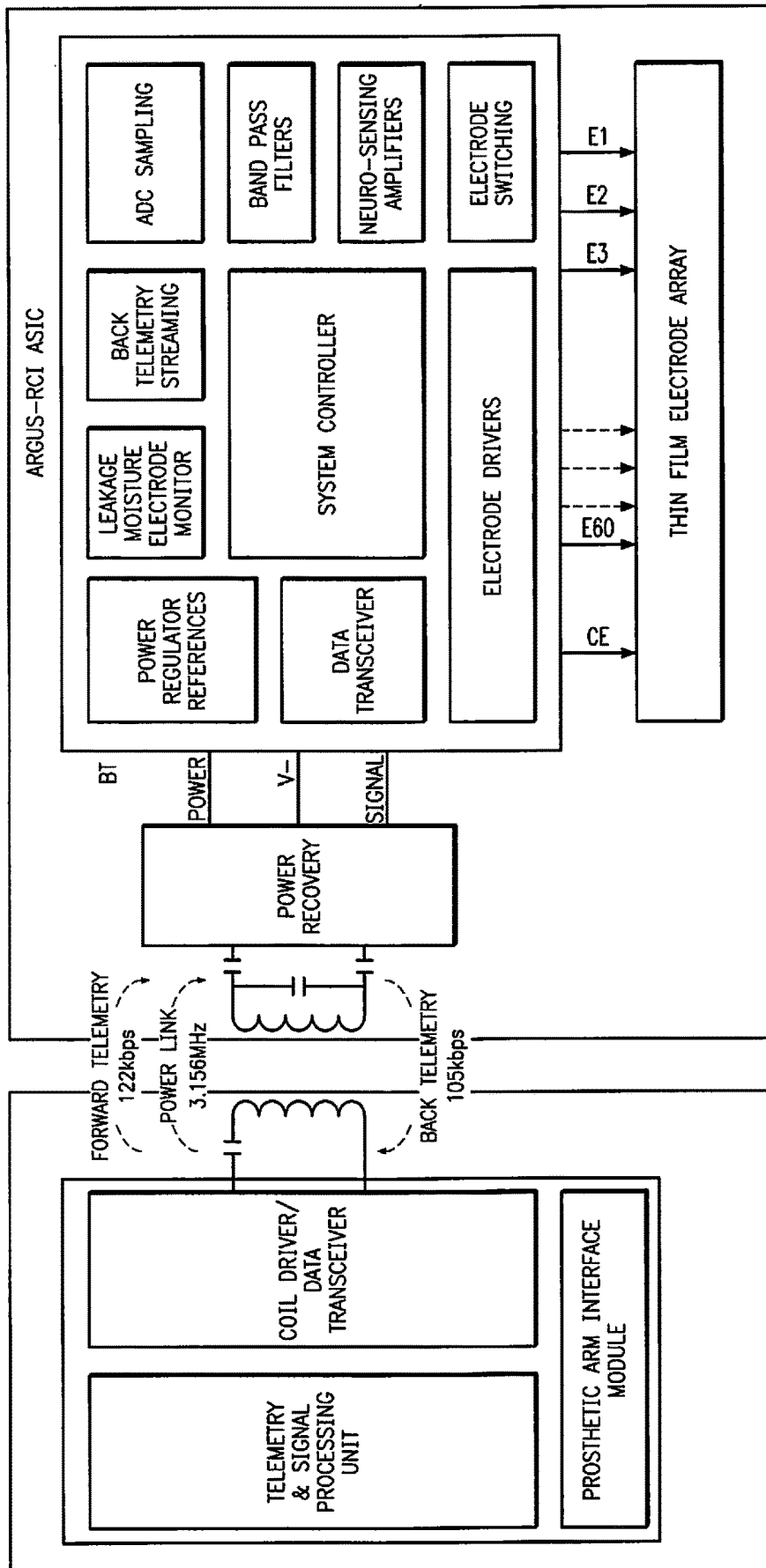

FIG. 74

**CORTICAL INTERFACE FOR MOTOR  
SIGNAL RECORDING AND SENSORY  
SIGNAL STIMULATION**

CROSS REFERENCE TO RELATED  
APPLICATIONS

**[0001]** This application is a divisional application of U.S. patent application Ser. No. 13/473,470, filed May 16, 2012, for Cortical Interface for Motor Signal Recording and Sensory Signal Stimulation, which is related to and incorporates by reference US Patent application 2009/0124965, for Implantable Device for the Brain, filed Jul. 25, 2008, now U.S. Pat. No. 9,592,377.

FIELD OF THE INVENTION

**[0002]** The present invention is an implantable device for interfacing with neural tissue, primarily in order to record neural activity for the control of a motor prosthesis. Secondly the implantable device stimulates neural tissue to provide sensory feedback.

BACKGROUND OF THE INVENTION

**[0003]** Neural tissue can be artificially recorded from and stimulated by prosthetic devices that sense or pass pulses of electrical current through electrodes on such a device. The passage of current causes changes in electrical potentials across neuronal membranes, which can initiate neuron action potentials, which are the means of information transfer in the nervous system.

**[0004]** Based on this mechanism, it is possible to read information from, and input information into, the central nervous system by coding or decoding the sensory information as a sequence of electrical pulses, which are relayed to the central nervous system via the prosthetic device. In this way, it is possible to provide active motor prostheses and create artificial sensations.

**[0005]** In 1986, Bullara (U.S. Pat. No. 4,573,481) patented an electrode assembly for surgical implantation on a nerve. The matrix was silicone with embedded iridium electrodes. The assembly fit around a nerve to stimulate it.

**[0006]** US Patent Application 2003/0109903 to Berrang describes a low profile subcutaneous enclosure, in particular, and metal over ceramic hermetic package for implantation under the skin.

**[0007]** ECoG (electrocorticography) and LFP (local field potentials) have been shown to provide data useful for BMIs (brain machine interfaces) (Mehring 2004) with LFPs containing more information content, but with higher surgical risk. Also in 2004, an online study by Leuthardt et al. (Leuthardt 2004) showed that ECoG can support accurate BMI operation with little user training. Additionally, this study also provided initial evidence that ECoG signals contain information about the direction of hand movements in particular. This finding was important in revealing that high frequency gamma rhythms provide information not simply on focal cortical activations, but rather convey specific information about cognitive intent. Distinct from single unit studies, this is one of the earliest demonstrations that cognitive intent could be inferred from large population scale cortical physiology.

**[0008]** EEG is non-invasive and has supported important BMI applications, including two- and three-dimensional movement control (Farwell 1988 a,b; Wolpaw 1991 a, b,

1994, 2002, 2004; Sutter 1992; McFarland 1993, 2008, 2010; Pfurtscheller 1993; Birbaumer 1999; Kübler 1999, 2005; Pfurtscheller 2000; Milián 2004; Müller 2006; Vaughan 2006 Royer 2010). The highest functioning EEG-based BMIs, however, require a substantial degree of user training and their performance is often not reliable. BMIs that are based on intracortical recordings of action potential firing rates or local field potentials are on the opposite end of the performance and clinical spectrum (Georgopoulos 1986; Serruya 2002; Taylor 2002; Shenoy 2003; Anderson 2004; Lebedev 2005; Hochberg 2006; Santhanam 2006; Donoghue 2007; Velliste 2008). Though they can achieve a high level of multidimensional control, there still remains a significant and unresolved question regarding the long-term functional stability of intracortical electrodes, particularly for recording action potentials (Shain 2003; Donoghue 2004; Davids 2006). This lack of signal durability has important clinical implications, because signal loss would require frequent replacement of the implant which would be neurosurgically unacceptable. Despite encouraging evidence that current non-invasive and invasive BMI technologies can actually be useful to severely disabled individuals (Kübler 2005; Hochberg 2006; Sellers 2010), these shortcomings and uncertainties remain substantial barriers to widespread clinical adoption and implementation in humans.

**[0009]** Compared to EEG, ECoG has major advantages: higher spatial resolution (e.g., 1.25 mm (subdural recordings (Freeman 2000; Leuthardt 2009)) and 1.4 mm (epidural recordings (Slutzky 2010)) vs. several centimeters for EEG); higher amplitude (e.g., 50-100  $\mu$ V maximum vs. 10-20  $\mu$ V maximum for EEG); far less vulnerability to artifacts such as electromyographic (EMG) or electroocular (EOG) activity ((Freeman 2003) or (Ball 2009), respectively); and broader bandwidth (i.e., 0-500 Hz (Staba 2002) vs. 0-40 Hz for EEG). With respect to the larger bandwidth of ECoG compared to EEG, it is important to note that this advantage may be directly related to the larger amplitude of ECoG. Because ECoG generally follows a 1/frequency drop-off in signal power (Miller 2009), task-related brain signals may remain larger than the noise floor of the amplifier/digitizer, and thus be detectable, at higher frequencies than for EEG. Additionally, these higher gamma frequencies (60-500 Hz) have been shown to carry substantive information on cognitive motor and language intentions, and provide vital information for cognitive control features that are poorly accessible with EEG. In addition to these advantages of signal and information quality, ECoG electrodes (which do not penetrate cortex) should provide greater long-term functional stability (Pilcher 1973; Loeb 1977; Bullara 1979; Yuen 1987; Margalit 2003) than intracortical electrodes, which induce complex histological responses that may impair neuronal recordings. A recent study by Chao (2010) showed that the signal-to-noise ratio of ECoG signals, and the cortical representations of arm and joint movements that can be identified with ECoG are stable over several months (Schalk 2010).

**[0010]** A fully integrated implantable architecture that combines electrode array, signal amplification, and telemetry has many advantages in creating a practical neural interface for a BMI based prosthetic limb system. Several such systems have been designed (Wise 2005; Harrison 2007; Rouse 2011). Among them the 100-electrode wireless cortical neural recording system based on the Utah array

(Harrison 2007) represents the most up-to-date state-of-the-art in terms of electrode count, system integration and telemetry. It contains an array of 100 amplifiers (60 dB gain), a 10 bit ADC (analog to digital converter), an inductive power link, 20 kbps forward telemetry data, and an FSK back telemetry link with a data rate of 345 kbps. However, this system is built to record from a spike electrode array that has shown problems of long term encapsulation and signal degradation due in part to a mechanical stiffness mismatch. Additionally, the implant does not have a hermetic package with proven long-term reliability, like the Argus II. The newest implantable system intended for chronic BMI is the 16 electrode system built from the Medtronic ActivaPC neural stimulator by adding a “brain activity sensing interface IC” (Rouse 2011). By using ActivaPC’s system scheme, the main device is to be implanted in a place on the body away from the head, and the sensing electrode array to be connected to the device through an extension connector and subcutaneous cable. The neural sensing interface includes sub- $\mu$ V resolution and is intended for both LFP and ECoG based control. However, it is a prototype system that is built for proof of concept and not a clinical device. Furthermore, the use of the extension connector and long subcutaneous cable is still susceptible to infection and cannot avoid the relatively common lead breakage problems associated with the ActivaPC device (Hamani 2006; Blomstedt 2005; Fernandez 2010). Additionally, having the amplifiers so distant from the recording sites increases the introduction of noise. Also, the use of an implant battery limits its long term capabilities. Further, the long-leads limit MRI to low levels—an important clinical consideration.

[0011] No single state-of-the-art system contains all the key features necessary for a practical, chronically implantable, and reliable CNS-interface system with a long life.

#### SUMMARY OF THE INVENTION

[0012] The present invention consists of an implantable device with at least one package that houses electronics that send and receive data or signals, and optionally, power, from an external system through at least one coil attached to at least one package, and processes the data, including recordings of neural activity, and/or delivers electrical pulses to neural tissue through at least one array of multiple electrodes that is/are attached to the at least one package. The device is adapted to electrocorticographic (ECoG) and local field potential (LFP) signals. The output signals provide control for a motor prosthesis and the input signals provide sensory feedback for the motor prosthesis. The invention, or components thereof, is/are intended to be installed in the head, or on or in the cranium or on the dura, or on or in the brain. Variations of the embodiments depend on the physical locations of the coil(s), package(s) and array(s) with respect to the head, cranium, dura, and brain. Novel features of the present invention include the small size of the implantable package which houses the controller, the high number of electrodes that are provided for sensing and/or stimulation, and the methods for manufacturing such a device. These features have unique applications in neural sensing and/or stimulation to treat or prevent disorders or disease. Other novel features will be made evident in the descriptions below.

[0013] The present invention includes an improved hermetic package connected to a thin film array and a coil, for implantation in the human body, and particularly in the

human head, for the purposes of sensing and stimulating the brain on the surface or at some depth. The implantable device of the present invention includes an electrically non-conductive substrate including electrically conductive vias through the substrate. A circuit is flip-chip bonded to a subset of the vias or traces connected to the vias. A second circuit is wire bonded to another subset of the vias or traces connected to the vias. A cover is bonded to the substrate such that the cover, substrate, and vias form a hermetic package. Finally, at least one thin film electrode array is attached to this package mechanically and electrically such that the electrode may sense neural activity or stimuli emitted from the electronics within the package, which then may be transmitted to areas of the brain.

#### BRIEF DESCRIPTION OF THE DRAWINGS

[0014] FIG. 1 shows the preferred package for the present invention illustrating basic structure and means of attachment.

[0015] FIG. 2A shows the preferred invention as implanted for neural recording.

[0016] FIG. 2B shows an alternate implantation location for brain surface stimulation.

[0017] FIG. 3 is a perspective view of a partially built package showing the substrate, chip, and the package wall.

[0018] FIG. 4 is a perspective view of the hybrid stack placed on top of the chip.

[0019] FIG. 5 is a perspective view of the partially built package showing the hybrid stack placed inside.

[0020] FIG. 6 is a perspective view of the lid to be welded to the top of the package.

[0021] FIG. 7 is a view of the completed package attached to an electrode array.

[0022] FIG. 8 is a cross-section of the package.

[0023] FIG. 9 is a top view of the ceramic substrate showing the metal traces for redirecting electrical connections.

[0024] FIG. 10A is a bottom view of the ceramic substrate showing the metal traces for redirecting electrical connections.

[0025] FIG. 10B is a bottom view of the ceramic substrate prior to metallization showing the vias through the substrate.

[0026] FIG. 11 depicts a top view of a finished feedthrough assembly in accordance with the present disclosure, comprised of a ceramic sheet having electrically conductive vias extending therethrough.

[0027] FIG. 12 depicts a sectional view taken substantially along the plane 12-12 of FIG. 11 showing the electrically conductive vias end flush with the surfaces of the ceramic sheet.

[0028] FIG. 13 depicts a flow diagram illustrating a possible series of process steps for fabricating a feedthrough assembly in accordance with the present disclosure.

[0029] FIGS. 14A-14M respectively depict the fabrication stages of a feedthrough assembly in accordance with the process flow illustrated in FIG. 13, wherein FIG. 14A depicts a sectional view of a ceramic sheet, and FIGS. 14B-C depict via holes being punched in the sheet of FIG. 14A.

[0030] FIGS. 14D-E depict exemplary stencil printing with vacuum pull down process.

[0031] FIG. 14F depicts paste inserted into the via holes.

[0032] FIGS. 14G-H depict exemplary multilayer lamination process.

- [0033] FIG. 4I shows an exemplary laminated substrate.
- [0034] FIGS. 14J-K depict lapping/grinding process.
- [0035] FIGS. 14L-M depict dicing of the substrate to form multiple feedthrough assemblies.
- [0036] FIG. 15 is the preferred implantation of the preferred invention in the brain.
- [0037] FIGS. 16A-E show the method of attaching a thin film array to the electronics package.
- [0038] FIGS. 17A-B show the thin film array of the present invention.
- [0039] FIGS. 18A-C show the thin film array of the present invention in more detail, and an implantation tool.
- [0040] FIGS. 19A-B show the implantation location of the present invention.
- [0041] FIGS. 20A-C show alternate implantation locations for the present invention.
- [0042] FIGS. 21A-D show alternate embodiments including multiple implantable packages.
- [0043] FIGS. 22A-F show further alternate embodiments and configurations.
- [0044] FIGS. 23A-C show further alternate embodiments, including a penetrating electrode array.
- [0045] FIG. 24 is a schematic diagram of the brain to further illustrate areas which could be stimulated by the present invention.
- [0046] FIGS. 25A-25E depict molds for forming the flexible circuit array in a curve.
- [0047] FIG. 26 depicts an alternate view of the invention with ribs to help maintain curvature and prevent tissue damage.
- [0048] FIG. 27 depicts an alternate view of the invention with ribs to help maintain curvature and prevent tissue damage, fold of the flexible circuit cable, and a fold A between the circuit electrode array and the flexible circuit cable.
- [0049] FIG. 28 depicts the flexible circuit array before it is folded and attached to the implanted portion.
- [0050] FIG. 29 depicts the flexible circuit array, folded.
- [0051] FIG. 30 depicts a flexible circuit array with a protective skirt.
- [0052] FIG. 31 depicts a flexible circuit array with a protective skirt bonded to the back side of the flexible circuit array.
- [0053] FIG. 32 depicts a flexible circuit array with a protective skirt bonded to the front side of the flexible circuit array.
- [0054] FIG. 33 depicts a flexible circuit array with a protective skirt bonded to the back side of the flexible circuit array and molded around the edges of the flexible circuit array.
- [0055] FIG. 34 depicts a flexible circuit array with a protective skirt bonded to the back side of the flexible circuit array, molded around the edges of the flexible circuit array, and flush with the front side of the array.
- [0056] FIG. 35 is an enlarged view of a single electrode within the flexible circuit electrode array.
- [0057] FIG. 36 depicts the flexible circuit array before it is folded and attached to the implanted portion, containing an additional fold between the flexible electrode array and the flexible cable.
- [0058] FIG. 37 depicts the flexible circuit array of FIG. 16, folded, containing an additional fold between the flexible electrode array and the flexible cable.
- [0059] FIG. 38 depicts a flexible circuit array of FIG. 17 with a protective skirt, and containing an additional fold between the flexible electrode array and the flexible cable.
- [0060] FIG. 39 depicts a top view of a flexible circuit array and flexible circuit cable showing an additional horizontal angle between the flexible electrode array and the flexible cable.
- [0061] FIG. 40 depicts another variation without the horizontal angle between the flexible electrode array and the flexible cable, but with an orientation of the electrodes in the flexible electrode array, as shown for the variation in FIG. 19.
- [0062] FIG. 41 depicts a top view of a flexible circuit array and flexible circuit cable wherein the array contains a slit along the length axis.
- [0063] FIG. 42 depicts a top view of a flexible circuit array and flexible circuit cable wherein the array contains a slit along the length axis with two attachment points.
- [0064] FIG. 43 depicts a flexible circuit array with a protective skirt bonded to the back side of the flexible circuit array with a progressively decreasing radius.
- [0065] FIG. 44 depicts a flexible circuit array with a protective skirt bonded to the front side of the flexible circuit array with a progressively decreasing radius.
- [0066] FIG. 45 depicts a flexible circuit array with a protective skirt bonded to the back side of the flexible circuit array, and molded around the edges of the flexible circuit array with a progressively decreasing radius.
- [0067] FIG. 46 depicts a flexible circuit array with a protective skirt bonded to the back side of the flexible circuit array, molded around the edges of the flexible circuit array, and flush with the front side of the array with a progressively decreasing radius.
- [0068] FIG. 47 depicts a side view of the flexible circuit array with a skirt containing a grooved and rippled pad instead of a suture tab.
- [0069] FIG. 48 depicts a side view of the enlarged portion of the skirt shown in FIG. 47 containing a grooved and rippled pad and a mattress suture.
- [0070] FIG. 49 depicts a flexible circuit array with a protective skirt bonded to the front side of the flexible circuit array with individual electrode windows.
- [0071] FIG. 50 depicts a flexible circuit array with a protective skirt bonded to the back side of the flexible circuit array and molded around the edges of the flexible circuit array with individual electrode windows.
- [0072] FIGS. 51-56 show several surfaces to be applied on top of the cable.
- [0073] FIG. 57 depicts the top view of the flexible circuit array being enveloped within an insulating material.
- [0074] FIG. 58 depicts a cross-sectional view of the flexible circuit array being enveloped within an insulating material.
- [0075] FIG. 59 depicts a cross-sectional view of the flexible circuit array being enveloped within an insulating material with open electrodes and the material between the electrodes.
- [0076] FIG. 60 depicts a cross-sectional view of the flexible circuit array being enveloped within an insulating material with open electrodes.
- [0077] FIG. 61 depicts a cross-sectional view of the flexible circuit array being enveloped within an insulating material with electrodes on the surface of the material.

[0078] FIG. 62 depicts a side view of the enlarged portion of the flexible circuit array being enveloped within an insulating material with electrodes on the surface of the material inside the eye.

[0079] FIG. 63 shows the whole flexible polymer array with the bond pad and the traces with holes at the edge of the electrode array.

[0080] FIG. 64 shows an enlarged view of the electrode array with holes at the edge for providing a protective skirt.

[0081] FIG. 65 shows a cross-sectional view of a polyimide array coated with PDMS (polydimethylsiloxane).

[0082] FIG. 66 shows a sequence of steps 1 to 8 for coating a polyimide electrode with PDMS.

[0083] FIG. 67 shows a sequence of steps 1 to 7 for coating a polyimide electrode with PDMS.

[0084] FIGS. 68A-D show a thin film array with penetrating electrodes.

[0085] FIGS. 69A-D show a thin film array with electrodes on both sides of the array.

[0086] FIGS. 70A-C show penetrating electrodes individually mounted to a thin film array and insulated penetrating electrodes with openings on their sides.

[0087] FIG. 71 shows an alternative penetrating flexible circuit electrode array.

[0088] FIG. 72 shows a hybrid surface and penetrating flexible circuit electrode array.

[0089] FIG. 73 shows an insertion tool for a penetrating flexible circuit electrode array.

[0090] FIG. 74 is a block diagram of a motor control prosthesis using the brain implant of the present invention.

[0091] In the following description, like reference numbers are used to identify like elements. Furthermore, the drawings are intended to illustrate major features of exemplary embodiments in a diagrammatic manner. The drawings are not intended to depict every feature of every implementation, nor relative dimensions of the depicted elements, and are not drawn to scale.

#### DETAILED DESCRIPTION OF THE PREFERRED EMBODIMENTS

[0092] The following description is of the best mode presently contemplated for carrying out the invention. This description is not to be taken in a limiting sense, but is made merely for the purpose of describing the general principles of the invention. The scope of the invention should be determined with reference to the claims.

[0093] This application is a cortically driven motor prosthesis: electrodes implanted on or in a motor strip, which when activated cause involuntary movements in the subject. The implant provides control for an external robotic prosthesis—an implant with recording electrodes on or in a pre-motor (forward of motor strip) or motor strip, which sends data wirelessly to an external processor, which drives a robotic limb (arm, hand, leg, foot), or stimulates muscles in a deinnervated arm, hand, leg, foot, face, tongue, etc.

[0094] A motor signal neural recorder and a somatosensory prosthesis providing motor control and external or implantable sensors that respond to

[0095] 1. Pressure

[0096] 2. Temperature (heat or cold) or

[0097] 3. Harmful stimuli such as sharp objects which send data to a processor that then sends the information to an implanted prosthesis with stimulating electrodes

on or in the somatosensory strip. In the preferred embodiment, the implantable portion measures ECoG and LFP signals.

[0098] The preferred device provides for selectable sensing electrodes. That is, any electrode, or electrodes, within the array may be connected to any recording channel or any stimulation driver to adapt the device for most effective recording of neural activity. All programmable functions are controlled by an external device through a bidirectional wireless link.

[0099] Several novel features of this system are described herein; small size (i.e. can be implanted on the brain or dura to eliminate cable tethering effects), novel stable high surface area electrode material, RF powered (i.e. no battery to replace), MRI compatibility, demonstrated biostability in delicate neural tissue, paper-thin micro-machined array cable designed to cross the sclera or dura interface without infection risk, 60 200 um disc electrodes in 3x5 mm area.

[0100] This invention includes recording capability to the stimulator with a modified mechanical configuration to permit epidural, subdural micro-ECoG (electrocorticography), and/or intracortical LFP (local field potential) signal recordings. Many approaches have been taken to BMIs (Brain Machine Interfaces). They range from non-invasive (but impractical for portable use) MEG, PET, and fMRI, to very invasive microelectrode wires or arrays for recording single-unit action potentials.

[0101] Brain tissue has an elastic modulus in the range of 10-100 kPa. Many of the probes used, on the other hand, have elastic moduli on the order of 160 GPa—a clear mismatch. The Argus II array, as described in U.S. Pat. No. 8,014,827 for *Flexible Circuit Electrode Array*, is polymer encapsulated with an elastic modulus of 2 MPa—much closer to the native brain tissue. This micro-machined array was designed to interface with the retina of a moving eye (neural tissue with the consistency of 1-ply wet tissue paper)—an even greater interface challenge than the comparatively tougher brain tissue.

[0102] With modifications to the existing Argus II array design, it can be configured to be placed as a subdural micro-ECoG array, or intracortically as an LFP recording array. For micro-ECoG, the electrode array would be similar to the current retinal prosthesis array, except it would be flat instead of curved making it easier to fabricate than the retinal array. One advantage of micro-machined arrays is that the electrode size and spacing can be almost arbitrarily specified. We have produced arrays with electrodes as small as 25  $\mu\text{m}$  in diameter up to as large as several millimeters. The array has a flexible thin-film cable to connect it to the electronics package (see FIG. 1).

[0103] To implant the Argus II intracortically, the array is divided up into ‘fingers’ to allow for penetration into the cortex with minimal trauma. The electrode size would be minimized to permit the fingers of the array to be as narrow as possible. Each finger would have multiple electrodes that could be elongated to maximize electrode area while minimizing finger width. Each finger would have a reinforced hole at the end of it to receive the tips of the insertion tool (introducer) which would be used to insert the electrodes through an incision.

[0104] Finally, a combined approach is envisioned with both subdural micro-ECoG electrodes and intracortical electrodes. This approach is a hybrid of the two possible alternate embodiments.

**[0105]** Several new technologies were required to build the Argus II implant. Major technological advances were made in the array, electrode material, hermetic implantable package, and implantable interconnect. These advances are discussed further below:

**[0106]** Thin-film electrode array (TFEA) is a thin film array (about 10  $\mu\text{m}$  thick) that employs a biocompatible polyimide as the substrate, with photolithographically patterned platinum metallization. Several modifications were made to the TFEA manufacturing process in order to improve metal to polyimide and polyimide to polyimide adhesion, and hence extend the lifetime of the device to many decades.

**[0107]** Accelerated soak testing of a dozen samples of the final design at 87° C. and, under 5 V DC bias, has resulted in a mean lifetime of 80 years and longest running samples have lifetimes in excess of 100 years. Flexural testing (120 degree bend around a 5 mm radius of curvature) on eight samples showed that each surpassed 25 million cycles without failure.

**[0108]** Analytical testing of long-term implants after 14-months in a human subject by SEM/EDX (Scanning electron microscope with energy dispersive X-ray spectroscopy) confirms no change in array's polymer chemical composition and no fibrosis encapsulation is evident.

**[0109]** Advanced Electrode Material: A novel electrode material, Platinum Gray' as described in U.S. Pat. No. 6,974,533 for Platinum Electrode and Method of Manufacturing the Same, provides significantly lower impedance than any other commercial material. This reduced impedance is important for recording microelectrodes since it improves the signal to noise ratio and reduces cross-talk (Rouse 2011).

**[0110]** Advanced Implantable Electronics Packaging: No polymer electronics casing that we tested lasted more than a few months in soak tests. The 'hard case' package of the Argus II described in U.S. patent application Ser. No. 11/385,314, filed Mar. 20, 2006, for Package for an Implantable Neural Stimulation Device, consists of a base ceramic layer with hermetic platinum feedthroughs and a solid metal side wall that is brazed onto the ceramic. A lid, which also acts as the electrical return for the implant, is then welded onto the braze wall to complete the package. A high density implantable interconnect process to connect the package to the TFEA is also describe herein.

**[0111]** Final device testing: A dozen Argus II devices have undergone real time and accelerated soak testing in the finished device level as part of a validation protocol. To date, none of these devices have failed (leak or material dissolution) and their lifetime is approaching 30 years. In addition, more than a dozen active Argus II devices have undergone in vivo testing in canines for six months without a failure. The Argus II implant is the only device of its kind to pass the FDA's tough standards for long-term human trials. To date, Argus II has been implanted in 30 patients worldwide. The longest implanted patients are approaching 4 years of use, and no device failures have been observed except for one intermittent RF link attributed to the misuse of a sharp surgical tool early in the trial. The Argus II Neural Stimulator meets all the biocompatibility requirements of ISO 10993-1 and FDA guidance G95-1. The implants were tested for cytotoxicity, irritation, sensitization, acute systemic toxicity, pyrogenicity, subchronic toxicity, genotoxicity and implantation.

**[0112]** Leveraging experience from successfully designing the chronically implantable Argus II Retinal Prosthesis, the present invention implant similarly includes a coil, thin film electrode array, and implant electronics housed in a hermetic package. For the present invention, the implant coil is located subcutaneously under the scalp, or possibly on the brain or dura, and receives power from an external coil placed over the scalp through inductive coupling.

**[0113]** The implant power recovery circuit retrieves DC power from the RF power carrier to supply the ASIC (Application Specific Integrated Circuit). Amplitude modulated data from the AES (Argus external system) is sent to the implant at a data rate of 122 kbps. The transceiver on the ASIC chip decodes this telemetry data (referred to as forward telemetry), which carries implant control commands that include electrode selection for each neural sensing channel, gain selection, sampling control, and other safety and diagnostic commands. The forward telemetry also supports CNS (Central nervous system) electrode stimulation commands for up to 60 electrodes, which may be used in future designs of the system. The Argus II implant ASIC is modified to include 16 neural sensing channels and reliably conveys this information to the AES. The channels each contain a differential neural amplifier that can sense sub- $\mu\text{V}$  neural signals and a band pass filter for a specified y band of 75-105 Hz, which can be assigned or reassigned to other frequencies by the AES. The amplified and band filtered signals from the specified channels are sampled by an ADC without data reduction at a rate up to 480 Hz per channel and with sub- $\mu\text{V}$  input resolution. Raw data from the ADC is streamed to the AES directly through a wireless link (referred to as back telemetry) designed with a bandwidth capable of handling the data flow in real time. The back telemetry data words include a header and CRC (cyclic redundancy check) to ensure bit error detection. The back telemetry employs a Frequency-shift Keying scheme whose carrier frequency is selected to minimize susceptibility to anticipated interfering signals. The ASIC also includes a dedicated channel and a 1 KHz test signal generator for analyzing electrode impedance values and thus determining the health of the electrode array.

#### The AES Subsystem

**[0114]** The AES is a modified version of the Argus II External System, designed to interface with the implant. The AES consists of telemetry electronics and an embedded microprocessor system. The telemetry electronics receives and demodulates the back telemetry data, while simultaneously providing power and forward telemetry to the implant. Data to the implant is amplitude modulated at a modulation depth of 10% on the 3.156 MHz power carrier. The microprocessor system uses a Texas Instruments OMAP 3530 microprocessor, which combines a 720 MHz ARM Cortex-A8 and a 520 MHz DSP. This system monitors the health and safety of the implant while continuously streaming neural sensing commands to the implant and receiving sensed neural data from the implant. In addition, the AES is responsible for processing the sensed neural data in real time to extract spectral power, track power fluctuations and further analyze and format the data to output multiple independent motor-control signals for the interface module. Data flow to the interface module is managed in real time, implementing error detection and correction schemes to ensure a high quality data link. The system also has the

ability to store the history of chronic sensed neural data for offline analysis geared towards signal optimization and patient personalization. To enhance the overall flexibility of the system, the AES firmware is field-upgradeable.

[0115] The implant sub-component of the present invention is designed to be a completely implantable neural sensing interface (for micro ECoG and Local Field Potentials). The implant has integrated low-noise neural sensing circuits and data telemetry close to the recording sites and is based on a predictable device that has been clinically proven to demonstrate long-term hermeticity and device reliability. Extensive in-vitro and in-vivo verification and validation testing was performed prior to a 30 subject clinical trial with nearly 80 subject years without a device failure (note: one intermittent device was traced to a surgical error). The small form factor of the implant facilitates a minimally invasive surgical procedure and has no end-of-life battery restrictions because no battery is required in the implant. The implant has no need for transcutaneous or subcutaneous wire leads which results in a low likelihood of complications such as infection, migration and mechanical damage to the leads. The implant is fully MRI compatible. The AES subsystem is field programmable to configure sensing parameters and power extraction algorithms and is built upon proven technology optimized for low power devices.

[0116] Overall, the present invention has the capability to robustly and reliably acquire and process neural signals (micro ECoG and Local Field Potentials) in real time, generating output motor control signals that are used to obtain up to 8 degrees of control for an arm prosthesis.

[0117] A preferred embodiment of the present invention, shown in FIG. 1, consists of an electronics package 14 that is preferably oval or circular in shape (but other shapes are possible) less than 20 mm in diameter (preferably less than 15 mm and more preferably less than 11 mm in diameter), and that is less than 5 mm in height (preferably less than 4 mm and more preferably less than 3.5 mm in height), that is mounted on top of the cranium but under the skin. The package may include a feature for mounting to the cranium such as a low profile flange 2 defining holes 3 to accommodate screws (not shown), or tabs 4 that allow screws, sutures, or staples to be taken to fix the package. Attached to, and proceeding from, the package 14 is a thin film lead 10 to be routed to the tissue to be stimulated or recorded from.

[0118] FIG. 2 shows attachment of the package 14 to the cranium 7. Alternately, the package 14 may be affixed to the cranium through the use of one or more straps, or the package 14 may be glued to the cranium using a reversible or non-reversible adhesive attach. In this embodiment, the package, which protrudes from the cranium, is low profile and shaped in a manner that permits the scalp 8 to rest on top of the package with little or no irritation of the scalp. Additionally, edges of the package are preferably rounded, and/or the package 14 may be encased in a soft polymer mold such as silicone to further reduce irritation. In other embodiments, the package 14 may be attached to the scalp 8, brain 11, or dura 12. In embodiments with more than one package, each package may be attached to any of the scalp, cranium, dura, or brain.

[0119] The improved package of the present invention allows for miniaturization of the package, which is particularly useful in brain sensors, stimulators, and other prostheses for electrical sensing and stimulation of neural tissue.

[0120] The electronics package 14 is electrically coupled to a secondary inductive coil 16. Preferably, the secondary inductive coil 16 is made from wound wire. Alternately, the secondary inductive coil 16 may be made from a flexible circuit polymer sandwich with wire traces deposited between layers of flexible circuit polymer. The electronics package 14 and secondary inductive coil 16 are held together by the molded body 18. The molded body 18 holds the electronics package 14 and secondary inductive coil 16 end to end. This is beneficial as it reduces the height the entire device rises above the sclera. The design of the electronics package (described below), along with a molded body 18 which holds the secondary inductive coil 16 and electronics package 14 in the end to end orientation, minimizes the thickness or height above the sclera of the entire device.

[0121] The molded body 18 may also include the flange 2 or suture tabs 4. The molded body 18, flange 2, and suture tabs 4 are preferably an integrated unit made of silicone elastomer. Silicone elastomer can be formed in a pre-curved shape to match the curvature of the implantation site. However, silicone remains flexible enough to accommodate implantation and to adapt to variations in the curvature at a particular site. Alternately, the flange 2 and/or suture tabs 4 may be formed of the same material(s) as the package (that is, integrated with the package), and the molded body 18 can be used to hold the coil 16 and package 18 together.

[0122] Referring to FIG. 3, the hermetic electronics package 14 is composed of a ceramic substrate 60 brazed to a metal case wall 62 which is enclosed by a laser welded metal lid 84. The metal of the wall 62 and metal lid 84 may be any biocompatible metal such as Titanium, niobium, platinum, iridium, palladium, or combinations of such metals. The ceramic substrate is preferably alumina but may include other ceramics such as zirconia. The ceramic substrate 60 includes vias (not shown) made from biocompatible metal and a ceramic binder using thick-film techniques. The biocompatible metal and ceramic binder is preferably platinum flakes in a ceramic paste, or frit, which is the ceramic used to make the substrate. After the vias have been filled, the substrate 60 is fired and lapped to thickness. The firing process causes the ceramic to vitrify binding the ceramic of the substrate with the ceramic of the paste forming a hermetic bond.

[0123] The package wall 62 is brazed to the ceramic substrate 60 in a vacuum furnace using a biocompatible braze material in the braze joint. Preferably, the braze material is a nickel titanium alloy. The braze temperature is approximately 1000° Celsius. Therefore the vias and thin film metallization 66 must be selected to withstand this temperature. Also, the electronics must be installed after brazing. The chip 64 is installed inside the package using thermo-compression flip-chip technology. The chip is under-filled with epoxy to avoid connection failures due to thermal mismatch or vibration.

[0124] Referring to FIGS. 4 and 5, off-chip electrical components 70, which may include capacitors, diodes, resistors, or inductors (passives), are installed on a stack substrate 72 attached to the back of the chip 64, and connections between the stack substrate 72 and ceramic substrate 60 are made using gold wire bonds 82. Alternately, discrete components, or a circuit board, may be attached to the ceramic substrate. A flip-chip integrated circuit and/or hybrid stack is preferred as it minimizes the size of the package 14. The

stack substrate 72 is attached to the chip 64 with non-conductive epoxy, and the passives 70 are attached to the stack substrate 72 with conductive epoxy. Thin-film metallization 66 is applied to both the inside and outside surfaces of the ceramic substrate 60 and an ASIC integrated circuit chip 64 is bonded to the thin film metallization on the inside of the ceramic substrate 60.

[0125] Referring to FIG. 6, the electronics package 14 is enclosed by a metal lid 84 that, after a vacuum bake-out to remove volatiles and moisture, is attached using laser welding. A getter (moisture absorbent material) may be added after vacuum bake-out and before laser welding of the metal lid 84. Further, the metal lid 84 has a metal lip 86 to protect components from the welding process and further insure a good hermetic seal. The entire package is hermetically encased. Hermeticity of the vias, braze, and the entire package is verified throughout the manufacturing process.

[0126] The implant secondary inductive coil 16, which provides a means of establishing the inductive link between the external processor (not shown) and the implanted device, preferably consists of gold wire. The wire is insulated with a layer of silicone. The secondary inductive coil 16 may be oval shaped. The conductive wires are wound in defined pitches and curvature shape to satisfy both the functional electrical requirements and the surgical constraints. The secondary inductive coil 16, together with the tuning capacitors in the chip 64, form a parallel resonant tank that is tuned at the carrier frequency to receive both power and data.

[0127] Referring to FIG. 7, the flexible circuit thin film lead 10 includes platinum conductors 94 insulated from each other and the external environment by a biocompatible dielectric polymer 96, preferably polyimide. One end of the array contains exposed electrode sites that are placed in close proximity to the surface to be stimulated or recorded from 333. The other end contains bond pads 92 that permit electrical connection to the electronics package 14. The electronics package 14 is attached to the flexible circuit 10 using a flip-chip bumping process, and is epoxy underfilled. In the flip-chip bumping process, bumps containing conductive adhesive placed on bond pads 92 and bumps containing conductive adhesive placed on the electronics package 14 are aligned and cured to build a conductive connection between the bond pads 92 and the electronics package 14. Leads 76 for the secondary inductive coil 16 are attached to gold pads 78 on the ceramic substrate 60 using thermal compression bonding, and are then covered in epoxy. The junction of the secondary inductive coil 16, thin film lead 10, and electronics package 14 are encapsulated with a silicone overmold 90 that connects them together mechanically. When assembled, the hermetic electronics package 14 may sit an arbitrary distance away from the end of the secondary inductive coil.

[0128] Since the implant device may be implanted just under the scalp it is possible to irritate or even erode through the scalp. Eroding through the scalp leaves the body open to infection. We can do several things to lessen the likelihood of scalp irritation or erosion. First, it is important to keep the overall thickness of the implant to a minimum. Even though it may be advantageous to mount both the electronics package 14 and the secondary inductive coil 16 on the cranium just under the scalp, the electronics package 14 is mounted higher than, and at a distance laterally displaced from, the secondary inductive coil 16. In other words the

thickness of the secondary inductive coil 16 and electronics package should not be cumulative.

[0129] It is also advantageous to place protective material between the implant device and the scalp. The protective material can be provided as a flap attached to the implant device or a separate piece placed by the surgeon at the time of implantation. Adding material over the device promotes healing and sealing of the wound. Suitable materials include Dacron, Teflon (polytetrafluoroethylene or PTFE), Goretex (ePTFE), Tutoplast (sterilized sclera), other processed tissue, Mersilene (Polyester) or silicone.

[0130] Referring to FIG. 8, the package 14 contains a ceramic substrate 60, with metallized vias 65 and thin-film metallization 66. The package 14 contains a metal case wall 62 which is connected to the ceramic substrate 60 by braze joint 61. On the ceramic substrate 60 an underfill 69 is applied. On the underfill 69 an integrated circuit chip 64 is positioned. On the integrated circuit chip 64 a ceramic hybrid substrate 68 is positioned. On the ceramic hybrid substrate 68 passives 70 are placed. Wirebonds 67 are leading from the ceramic substrate 60 to the ceramic hybrid substrate 68. A metal lid 84 is connected to the metal case wall 62 by laser welded joint 63 whereby the package 14 is sealed.

[0131] The electronics package 14 is electrically coupled to a secondary inductive coil 16. Preferably, the secondary inductive coil 16 is made from wound wire. Alternately, the secondary inductive coil 16 may be made from a flexible circuit polymer sandwich with wire traces deposited between layers of flexible circuit polymer. The electronics package 14 and secondary inductive coil 16 are held together by the molded body 18. The molded body 18 holds the electronics package 14 and secondary inductive coil 16 end to end. The secondary inductive coil 16 is placed around the electronics package 14 in the molded body 18. The molded body 18 holds the secondary inductive coil 16 and electronics package 14 in the end to end orientation and minimizes the thickness or height above the sclera of the entire device.

[0132] Referring to FIGS. 9 and 10, thin-film metallization 66 is applied to both the inside and outside surfaces of the ceramic substrate 60 and an ASIC integrated circuit chip 64 is bonded to the thin film metallization on the inside of the ceramic substrate 60.

[0133] The inside thin film metallization 66 includes a gold layer to allow electrical connection using wire bonding. The inside film metallization includes preferably two to three layers with a preferred gold top layer. The next layer to the ceramic is a titanium or tantalum, or mixture or alloy thereof. The next layer is preferably a palladium or platinum layer, or an alloy thereof. All these metals are biocompatible. The preferred metallization includes a titanium, palladium, and gold layer. Gold is a preferred top layer because it is corrosion resistant and can be cold bonded with gold wire. The outside thin film metallization includes a titanium adhesion layer and a platinum layer for connection to platinum electrode array traces. Platinum can be substituted by palladium or a palladium/platinum alloy. If gold-gold wire bonding is desired a gold top layer is applied.

[0134] The three layer stack of metallization consists of an adhesion layer, barrier layer, and a bonding layer. The adhesion layer is a metal best suited to bond with the ceramic. Titanium is a good adhesion layer material. Titanium is active enough to bond with ceramics, but still noble

enough to be bio-compatible. Alternative adhesion layers are chromium or tungsten. Both bond better, but are less bio-compatible. A non-bio-compatible adhesion layer may be used if it is adequately isolated from the body.

[0135] The center layer is a barrier layer. The preferred barrier layer for external traces is platinum, while palladium is the preferred barrier layer for internal traces. The barrier layer prevents, or reduces migration of the adhesion layer and bonding layer due to heat from the brazing process. Migration of the layers reduces the effectiveness of each layer. Other possible barrier layers are ruthenium, rhodium, molybdenum, or iridium. All of these materials are rare and expensive. Iridium is the only one that is reasonably bio-compatible.

[0136] The top layer is the bonding layer for bonding electrical connections. Gold is the preferred bonding layer. On the inside metallization, electrical circuits are flip-chip bonded, or wire-bonded to the gold bonding layer. On the outside, the coil 16 is compression bonded to the gold bonding layer. Alternatively, a thermo-compression process may be used. The electrode array cable is attached through a platinum epoxy paste. In this case, a gold bonding layer is counterproductive. Since the barrier layer is platinum, the gold bonding layer is etched from the array bond pads, allowing for a platinum to platinum bond.

[0137] Preferably, the layers are sputtered on the ceramic with the adhesion layer 500 to 1000 angstrom, the barrier layer 5000 angstrom, and the bonding layer 2000 angstrom. The traces are patterned with photo-resist and wet etched with potassium iodide. Additionally, the bonding layer may be electroplated to ten microns for a better bonding surface. Alternatively, a lift off process may be used. If a lift off process is used, care must be taken to completely clean photo-resist from trace areas to provide for good adhesion. The metallization includes capture pads to improve alignment with the vias.

[0138] It should also be noted that the thin film metallization 66 includes a single ring 67 completely around the interior or top surface of the substrate 60. When brazing, it common for braze material to flow further than desired, which is called braze run out. A single ring around the circumference of the substrate 60, sputtered and patterned as part of the thin film metallization, provides a dam to prevent braze run out from contacting and shorting the traces used for electrical redirection.

[0139] FIG. 10B shows the locations of the vias or feedthroughs 65 on the substrate 60 prior to sputtering the thin film metallization 66. The following discussion is directed to a method and apparatus suitable for forming hermetic electrical vias or feedthroughs in a ceramic sheet (or substrate) having a possible thickness of  $\leq 40$  mils, for the construction of the substrate 60, with metallized vias (feedthroughs) 65. The metallization includes capture pads to improve alignment with the vias.

[0140] Electrical feedthroughs in accordance with the present writing are intended to function in corrosive environments, e.g., in medical devices intended for implantation in a patient's body. In such applications, it is generally critical that the device housing be hermetically sealed, which, of course, requires that all feedthroughs in the housing wall also be hermetic. In such applications, it is also generally desirable that the weight and size of the housing be minimized and that all exposed areas of the housing be bio-compatible and electrochemically stable. Biocompatibil-

ity assures that the implanted device has no deleterious effect on body tissue. Electrochemical stability assures that the corrosive environment of the body has no deleterious effect on the device. Ceramic and platinum materials are often used in implantable medical devices because they typically exhibit both biocompatibility and electrochemical stability.

[0141] Embodiments constructed in accordance with the present disclosure are able to achieve very high feedthrough density. For example, in applications where miniaturization is important, the feedthrough pitch, i.e., center-to-center distance between adjacent feedthroughs, may be from 10 mils to 40 mils.

[0142] Attention is initially directed to FIGS. 11 and 12 which depict a preferred feedthrough assembly 108 in accordance with the present disclosure comprising a thin ceramic sheet 110 of ceramic material having multiple electrical feedthroughs 112 extending therethrough, terminating flush with the upper and lower surfaces 114, 116 of the sheet 100. The sheet 100 typically comprises a portion of a housing (not shown) for accommodating electronic circuitry. The feedthroughs 112 function to electrically connect devices external to the housing, e.g., adjacent to surface 114, to electronic circuitry contained within the housing, e.g., adjacent to surface 116. "Thin ceramic sheet" as used herein refers to a sheet having a finished thickness dimension of  $\leq 40$  mils, i.e., 1 mm. The apparatus in accordance with the disclosure is particularly suited for use in corrosive environments such as in medical devices implanted in a patient's body.

[0143] The present disclosure is directed to providing electrical feedthroughs that are compatible with thin ceramic sheets (or substrates) having a finished thickness of  $\leq 40$  mils, and with feedthroughs that are hermetic, bio-compatible, and electrochemically stable. In one exemplary embodiment, the ceramic sheet 110 may be formed of 90% aluminum oxide ( $\text{AlO}_2$ ) and the feedthroughs 112 may have a diameter of  $\leq 20$  mils and may be composed of paste containing, for example, platinum.

[0144] Attention is now directed to FIGS. 13 and 14A-14M which depict the possible process steps for fabricating the finished feedthrough assembly 108 illustrated in FIGS. 11 and 12.

[0145] Initially, a green ceramic sheet/tape/substrate 120 (FIG. 14A), formed, for example, of  $>90\%$  aluminum oxide ( $\text{AlO}_2$ ) is selected as represented by step 121 in FIG. 13. In an exemplary embodiment, the sheet 120 may have a thickness of 40 mils or less. "Green ceramic sheet/tape/substrate" as used herein refers to an unfired ceramic sheet, tape or substrate.

[0146] Via holes 126 are formed into the sheet 120 as represented by FIGS. 14B-14C and step 128 in FIG. 13. In an exemplary embodiment, each via hole 126 may be punched into the sheet 120 using, for example, programmable punch tool 127. In one exemplary embodiment, a plurality of via holes 126 may be punched at the same time. It is to be understood that other methods may be used to form via holes 126. For example, via holes 126 may be formed using solvent etching, laser ablation, and/or via holes 126 may be drilled.

[0147] Step 137 of FIG. 13 calls for selecting a conductive thick-film paste 117 to fill in via holes 126 depicted in FIG. 14C. "Thick-film paste" as used herein refers to a material containing inorganic particles dispersed in a vehicle comprising an organic resin and a solvent. Types of different

pastes are disclosed in U.S. Pat. No. 5,601,638, the disclosure of which is incorporated herein by reference.

[0148] In one exemplary embodiment, a stencil printing with vacuum pull down process may be used to fill via holes 126 with the conductive paste 117 as represented by FIGS. 14D-14E and step 139 in FIG. 13. During the stencil printing with vacuum pull down process, the sheet 120 may be sandwiched between a stencil layer 119 and a vacuum base 180. As a squeegee 118 roles the conductive paste 117 across the stencil layer 119, a vacuum chuck 181 of the vacuum base 180 pulls the conductive paste 117 through holes 182 of the stencil layer 119 and into the via holes 126 as shown in FIGS. 14D-14E.

[0149] Step 140 of FIG. 13 calls for determining if additional green ceramic sheet/tape/substrates with paste filled via holes are required. If additional green ceramic sheet/tape/substrates with paste filled via holes are required (“Yes” in step 140), steps 121, 128, 137 and 139 are repeated. If additional green ceramic sheet/tape/substrates with paste filled via holes are not required (“No” in step 140), step 141 of FIG. 13 is performed.

[0150] Upon completion of the stencil printing with vacuum pull down process and step 140, the sheet 120 with via holes 126 filled with conductive paste 17 shown in FIG. 14F may go through a multilayer lamination process as represented by FIGS. 14G-14H and step 141 in FIG. 13.

[0151] In the multilayer lamination process, the sheet 120 of FIG. 14F may be laminated with, for example, sheets 191 and 192 as shown in FIG. 14G. The sheets 191 and 192 may contain conductive paste filled vias 126 that are similar to the conductive paste filled vias 26 of the sheet 120 and the sheets 191 and 192 may be formed using steps 121, 128, 137 and 139 of FIG. 13 as described above.

[0152] During the multilayer lamination process, a) the sheets 120, 191 and 192 are stacked on top of each other with conductive paste filled vias 126 of each sheet being aligned on top of each other; b) stacked sheets 120, 191 and 192 are sandwiched between two unpunched green ceramic sheets/tapes/substrates 195 and 196; and c) the sheets 120, 191 and 192 and the sheets 195 and 196 are laminated together using a heat press 198 to create a/the laminated substrate 200 shown in FIG. 14I.

[0153] Although FIGS. 14G and 14H laminate three sheets 120, 191 and 192 with conductive paste filled vias 126, one skilled in the art can appreciate that this disclosure is not limited to three sheets and that a single sheet 120 with conductive paste filled vias may be laminated together with the sheets 195 and 196 without the additional sheets 191 and 192. Although FIGS. 14G and 14H laminate three sheets 120, 191 and 192 with conductive paste filled vias 126, one skilled in the art can appreciate that this disclosure is not limited to three sheets and that additional sheets with conductive paste filled vias may also be laminated together with sheets 120, 191 and 192.

[0154] Step 144 of FIG. 13 calls for the laminated substrate 200 to be fired. Firing of the laminated substrate 200 encompasses different aspects of forming bonds in ceramic (evaporation, binder burnout, sintering, etc.). The unpunched ceramic layers 195 and 196 of the laminated substrate 200 help to constrain the conductive paste within via holes 126 and allow for compression during the firing step 144. The unpunched ceramic layers 195 and 196 of the laminated substrate 200 also help to isolate the conductive paste filled vias 126 from the firing atmosphere during the

step 144 which may be the key to hermetic and low resistance paste filled vias 126. An exemplary firing schedule includes ramping the laminated substrate 200 of FIG. 14I up to 600° C. at a rate of 1° C./minute, then ramping up to 1600° C. at a rate of 5° C./minute, followed by a one hour dwell and then a cool-to-room-temperature interval.

[0155] During the firing and subsequent cooling during the step 144, the ceramic material of the laminated substrate 200 shrinks thereby shrinking via holes 126 around the paste 117 to form a seal. The fine aluminum oxide suspension permits uniform and continuous sealing around the surface of the paste 117. Additionally, at the maximum firing temperature, e.g., 1600° C., the paste 117 being squeezed by the ceramic exhibits sufficient flow to enable the paste 117 to flow and fill any crevices in the ceramic. This action produces a hermetic paste/ceramic interface. Furthermore, the firing step 144 may also cause hermeticity through bonding mechanisms like, for example, sintering, glass melt/wetting, alloying, compounding, and/or diffusion solution formation.

[0156] “Sintering” as used herein is a term used to describe the consolidation of the ceramic material during firing. Consolidation implies that within the ceramic material, particles have joined together into an aggregate that has strength. The term sintering may be used to imply that shrinkage and densification have occurred; although this commonly happens, densification may not always occur. “Sintering” is also a method for making objects from powder, by heating the material (below its melting point) until its particles adhere to each other. “Sintering” is traditionally used for manufacturing ceramic objects, and has also found uses in such fields as powder metallurgy. “Alloying” as used herein refers to an alloy that is a homogeneous hybrid of two or more elements, at least one of which is a metal, and where the resulting material has metallic properties. “Compounding” as used herein refers to a chemical compound that is a substance consisting of two or more elements chemically-bonded together in a fixed proportion by mass. “Diffusion solution formation” as used herein refers to the net movement of particles from an area of high concentration to an area of low concentration. A solid solution is a solid-state solution of one or more solutes in a solvent. Such a mixture is considered a solution rather than a compound when the crystal structure of the solvent remains unchanged by the addition of solutes, and when the mixture remains in a single homogeneous phase. Also, the firing step 144 may also cause solidification of the metalized vias 126 and the ceramic material of the laminated substrate 200 to prevent leaks.

[0157] Step 148 of FIG. 13 calls for lapping or grinding the upper and lower surfaces of the fired laminated substrate 200 to remove materials 150 and 151, depicted in FIG. 14J, in order to expose the upper and lower faces of the metalized vias 126. The upper and lower surfaces of the fired laminated substrate 200 may also go through the polishing step 149 so that the metalized vias 126 are flush with the surrounding ceramic material.

[0158] After lapping and/or grinding, the fired laminated substrate 200 may be subjected to a hermeticity test, e.g., frequently a helium (He) leak test as represented by step 156 in FIG. 13.

[0159] In one exemplary embodiment, sheet/substrate 120 may contain several patterns 124A-D of the via holes 126 as shown in FIG. 14L. In this exemplary embodiment, the fired

laminated substrate **200** would contain several patterns **124A-D** of the metal filled via holes **126** and the fired laminated substrate **200** would be subjected to a singulation or dicing step **158** to provide multiple feedthrough assemblies **160A, 160B, 160C, 160D**, shown in FIG. **14M**.

[0160] Although some embodiments described above employ a ceramic sheet of >90% aluminum oxide (AlO<sub>2</sub>), alternative embodiments may use other ceramic materials, e.g., zirconium. Because the firing temperature of the ceramic can be tailored within certain limits, the conductive paste **17** may comprise any of the noble metals and/or any of the refractory metals, for example, platinum, titanium, gold, palladium, tantalum, niobium.

[0161] The package of the present invention can be applied to many uses in the medical device industry. The present invention applies the package to neural sensing for motor control and stimulation for sensory feedback.

[0162] FIG. **15** shows the application of the package of the present invention to deep brain stimulation, as shown in FIG. **2A**, but in further detail. Due to the low profile of the package, the package **214** can be implanted in a hollowed out portion of the cranium **208**. The hollowed out portion may go part way through the cranium **208**, leaving part of the bone under the package **214**. Alternatively, the hollowed out portion may extend through the cranium and the package **214** rests on the dura **206**. This protects the package **214**, allows the package **214** to be placed close to the sensing or stimulation site, and avoids visible protrusions on the head. The package **214** contains a ceramic substrate **260** with metallized vias **265** and thin-film metallization **266**. The package **214** contains a metal case wall **262** which is connected to the ceramic substrate **260** by braze joint **261**. On the ceramic substrate **260** an underfill **269** is applied. On the underfill **269** an integrated circuit chip **264** is positioned. On the integrated circuit chip **264** a ceramic hybrid substrate **268** is positioned. On the ceramic hybrid substrate **268** passives **270** are placed. Wire bonds **267** are leading from the ceramic substrate **260** to the ceramic hybrid substrate **268**. A metal lid **284** is connected to the metal case wall **262** by laser welded joint **263**, whereby the package **214** is sealed. In addition, a rechargeable battery **280** is placed within the package **214** to allow the deep brain stimulator to operate without external power. A thin film array cable **212** leads to an electrode array **210** for sensing stimulation of brain tissue **204**. A coil **216** is placed close to the scalp to receive inductive power and data from an external coil (not shown) to program the electronics and recharge the battery **280**.

[0163] Also, a cover **282** such as Dacron mesh may be used to hold the package **216** in place. The cover **282** may be glued or screwed to the cranium. It should be noted that the package **214** is placed with the delicate ceramic substrate **260** protected with the more durable metal lid **284** just beneath the scalp.

[0164] FIG. **16** shows the preferred method of bonding the substrate **60** to the flexible thin film lead **10** using electrically conductive adhesive **381**, such as a polymer, which may include polystyrene, epoxy, or polyimide, and which contains an electrically conductive particulate of select biocompatible metal, such as platinum, iridium, titanium, platinum alloys, iridium alloys, or titanium alloys in dust, flake, or powder form.

[0165] In FIG. **16**, step A, the substrate **60**, and the input/output contacts **322** are prepared for bonding by

placing conductive adhesive **381** on the input/output contacts **322**, at the ends of the thin film metallization trace **66**. In step B, the flexible thin film lead **10** is preferably prepared for bonding to the substrate **60** by placing conductive adhesive **381** on bond pads **332**. Alternatively, the adhesive **381** may be coated with an electrically conductive biocompatible metal. The flexible thin film lead **10** contains the flexible electrically insulating substrate **338**, which is preferably comprised of polyimide. The bond pads **332** are preferably comprised of an electrically conductive material that is biocompatible when implanted in living tissue, and are preferably platinum or a platinum alloy, such as platinum-iridium.

[0166] FIG. **16**, step C illustrates the cross-sectional view A-A of step B. The conductive adhesive **381** is shown in contact with and resting on the bond pads **332**. Step D shows the hybrid substrate **60** in position to be bonded to the flexible thin film lead **10**. The conductive adhesive **381** provides an electrical path between the input/output contacts **322** and the bond pads **332**. Step E illustrates the completed bonded assembly wherein the flexible thin film lead **10** is bonded to the substrate **60**, thereby providing a path for electrical signals to pass to the living tissue from the package **14**. The assembly has been electrically isolated and hermetically sealed with adhesive underfill **380**, which is preferably epoxy.

[0167] Alternatively, the package may be constructed from a single or multiple layers of a single or multiple polymers, including but not limited to biocompatible epoxies, Parylene, polyimide, silicone, PDMS, PGA, Teflon, PEG, and PMMA.

[0168] To this package a polymer-based electrode cable **330**, array **331**, and a bond pad region **332** are attached. The cable, bond pad region, and array is a single integrated unit that forms the flexible thin film lead **10** shown in FIG. **17** with bond pads **335** at the proximal end and electrodes **333** at the distal end. The cable and array unit is composed of a base polymer **336** layer, one interlayer of patterned metal **337** (or a stack up of metals) comprising traces **33** and electrodes **333**, and a top polymer layer **338** that is patterned to expose the pads and electrodes, but insulate the traces. Such a cable and array may be referred to collectively as a thin film lead **10** and may be manufactured in a manner disclosed in U.S. patent application Ser. Nos. 11/207,644 and 11/702,735 incorporated herein by reference. Alternatively, the lead may consist of more than one metal interlayer and corresponding additional polymer interlayers so that the thin film lead may be considered a multilayer structure. In a more preferable embodiment, the polymer employed for the base layer, inter layer(s), and top layer is polyimide. Other possible polymers include Parylene, silicone, Teflon, PDMS, PMMA, PEG, and others.

[0169] The thin film lead consists of at least 30 independent pads, traces, and electrodes, or preferably at least 50, 60, 100, or 200 pads, traces, and electrodes. The advantages of having so many independent channels is that sensing or stimulation may be performed at several sites at once resulting in better therapy, or if combined with a sensing/recording/feedback mechanism either at the time of surgical implantation or throughout the life of the implant, optimal electrodes may be selected for sensing or stimulation, reducing the total power output required, which reduces power consumption and may also minimize the occurrence of side effects.

**[0170]** The electrodes of the thin film lead are preferably biocompatible and capable of sensing or delivering stimulation charge densities of at least  $0.1 \text{ mC/cm}^2$ . One metal often employed to deliver such charge densities is platinum but other noble metals and some metal oxides and nitrides may be used. Since it is an advantage of the current invention to have numerous electrodes, it may be necessary in some applications, where the array is to be small, to have the stimulating electrodes be small, preferably less than about  $500 \text{ }\mu\text{m}$ , or less than  $250 \text{ }\mu\text{m}$ , or less than  $200, 200, 50, 25$  and  $10 \text{ }\mu\text{m}$ . For such small electrodes, therapeutic doses of electrical current are likely to exceed  $0.1 \text{ mC/cm}^2$ , and in such cases it may be desirable to employ electrode materials that permit the safe use of higher charge densities. Two such electrode materials are platinum gray and super iridium oxide, disclosed in U.S. Pat. No. 6,974,533 and U.S. patent application Ser. No. 10/655,772 incorporated herein by reference.

**[0171]** The thin film lead **10** is intended to penetrate the cranium **7** through a surgical opening in the cranium and dura **12** and sit on the surface of the brain (FIG. **2B**.) such that the array **331** of electrodes **333** is at or near the intended target for sensing or stimulation, or the thin film lead may penetrate into the brain (FIG. **2A**.) so that the array of electrodes reaches the intended target for sensing or stimulation deep within the brain. Alternatively, the thin film lead may be placed on an inner surface of the brain between two or more lobes.

**[0172]** The thin film lead in one embodiment may be substantially flat and planar for its entire length. In other embodiments it may be desirable to shape all, much, or some of the lead. For example, it may be desirable to curve a region of the lead along its longitudinal axis into a columnar structure that is more rigid than the planar array (FIG. **18A**). In such a scenario the edges of the folded structure may or may not overlap and could be held in place with a binding material such as silicone **343** and **344**. This binding material could be beaded along the edge or applied to the entire edge or in distinct locations. It may also be desirable to have a sharpened tip **340** for this structure such that it may be used to penetrate the brain, and/or an introducer **341** that may be inserted into the columnar structure and used to guide the lead into place. In another embodiment (**184B**), where the array is intended to be placed on the surface of the brain, either for recording or stimulation, it may be desirable to shape the array region of the lead to conform to the intended target. Such shaping may be accomplished using molding or thermo-forming of the thermoset or thermoplastic polymers used in the lead. In any case where 3D shaping of the lead or components of the lead are desired, it may be desirable to include physical features in the planar thin film lead (such as cut outs **342**) that facilitate this shaping step. These cutouts could have a variety of shapes such as a rounded feature **345** or a slit **346**.

**[0173]** In an alternative embodiment (shown in FIG. **23**), it may be desirable to attach an array of penetrating electrodes **13** to the package(s), either in place of the thin film lead, or in addition to the thin film array. Such a penetrating array is composed of electrodes of an aspect ratio and sharpness suitable for allowing the array to penetrate the dura and/or brain in order to contact neurons that are not at the brain's surface. Such a penetrating array may be more suitable for recording neuronal activity, or sensing a physiological parameter than a surface thin film lead or a pen-

etrating thin film lead. Additionally, such an array may be able to stimulate cells within the brain more efficiently than the thin film leads. It may also be desirable to use a penetrating array for sensing/recording and a surface thin film lead for sensing or stimulation. It may be also be desirable to use a penetrating array for sensing and/or recording and/or stimulation and a surface thin film lead for sensing and/or recording and/or stimulation. FIG. **23A** shows an array of penetrating electrodes penetrating the brain in one location with a surface thin film lead in another location, while FIG. **23B** shows both types of arrays in a similar location. FIG. **23C** shows an embodiment that use a penetrating thin film lead in conjunction with a surface thin film lead.

**[0174]** The array and/or portions of the cable which comprise the thin film lead may be fixated to tissue (scalp, cranium, brain matter, or dura) using several possible techniques. One fixation method would employ a tack similar to that disclosed in U.S. patent application Ser. No. 09/975,427, incorporated herein by reference. In one embodiment the tack would penetrate through a hole in the array **345** or cable into neighboring tissue. In another embodiment at least two tacks would penetrate at least two holes in the cable and/or array. A biocompatible glue or adhesive may be used to fix the array and/or cable in place. This glue or adhesive may be preferentially reversible through the administration of light, heat, energy, or a chemical agent in order to allow rapid removal of the thin film lead. Electro-tacking, whereby one or more electrodes are sacrificed to fix the array to tissue by discharging a significant electrical current through the electrode, may also be employed. This process may also be reversible. Alternatively, physical features may be constructed in the polymer thin film lead that permit anchoring of the lead to adjacent tissue. Such features may be one or more protuberances that anchor into tissue when pressure is applied or holes that permit tissue growth through and around the lead. In another embodiment, regardless of the method of array attachment used, it may be desirable to attach the array to the inside (brain side) surface of the dura with the electrodes facing the brain. In this embodiment it may be necessary to put a spacer between the array and the dura in order to force the electrodes to be proximal to the brain tissue target for sensing or stimulation. One such spacer is made from a biocompatible sponge-like material. Additionally, one or more handle type structures **339** may be added to the thin film lead to permit holding of the lead or a region of the lead using surgical tools such as forceps, or end gripping forceps.

**[0175]** Attachment of the bond pad region **332** of the thin film lead **10** to the package **14** is carried out using a method or methods similar to those disclosed in U.S. Pat. Nos. 7,142,909 and 7,211,103 incorporated herein by reference.

**[0176]** One or more reference or return electrodes must be provided in order to provide a return for the stimulation current. A feature of the present invention is that the return electrode(s) be provided in or on the brain. The return electrodes may be contained on the thin film lead(s) containing the sensing or stimulation electrodes or they may be on their own independent leads that may or may not be thin film leads. Alternatively, the lid and/or other metal components of the package(s) may be used to provide an electrical return.

**[0177]** A coil **16** is also attached to the package **14**. This coil permits radio-frequency communication between the

implant and an external apparatus. This coil may receive power and data signals from the external apparatus and may send information about the implant or a sensed physiological condition out to the external apparatus. The coil may be attached to the package via wire leads **5** or alternatively may be attached to the polymer thin film lead **10** via bonding of the coil wires to additional bond pads in the polymer. Or in another embodiment, the coil may be integrated into polymer thin film lead as a patterned metal coil made from the same or a different metal stack up as that employed in the rest of the lead. The coil profile and shape is such that the scalp may rest of top of the coil without being irritated. Thus the coil is low profile with rounded edges and is preferably encased in a biocompatible soft polymer mold such as a silicone or other elastic polymers. The coil(s) facilitates transmission of data between the implant and the external system and possibly between implanted coils. In the case of a device without a rechargeable battery the coil is also used to receive power from an external source. It is a feature of the present invention that where the implanted coil(s) is to receive both power and data, at least two different carrier frequencies are used; one for power transmission and one or more for data transmission.

**[0178]** In another embodiment of the present invention, a sensor is employed in the device where the sensor is contained within the package, and/or on the thin film lead. As well, the electrodes (either on a penetrating array/lead or on a thin film surface lead) may be used to record electrical activity in the brain, or measure electrical properties of the entire system (i.e. impedance, or voltage waveforms). The output from such a sensor/recorder/measurement system may be used by the implanted electronics to determine a course of action, or the information may be telemetered out to the external system to be processed in order to determine a parameter of interest. The external system determines a course of action if necessary and telemeters that data back to the implant. Optionally, the external system may telemeter the calculated parameter value(s) back to the implant for subsequent decision making.

**[0179]** In another embodiment of the present invention (FIG. **19**), it may be desirable to countersink the package **14** into the cranium **7** in order to protect the device from damage due to an external blow to the head or to prevent irritation of the scalp (shown in FIG. **19A**). It may be desirable to turn the package upside down in such a configuration so that the thin film lead comes out on the surface of the cranium (as shown). Also, it may be desirable to countersink the coil **16** in the cranium **7** for the same reasons. Although a thin film multi-electrode lead is shown penetrating the brain in this figure, it is possible that the lead may rest on the surface of the brain or between lobes of the brain. Although no flange or tabs are shown on the package or coil in this figure, it is implied that such fixation features may be present.

**[0180]** In another embodiment of the present invention (FIG. **20**), it may be desirable to have the package **14** be of such a height that it just protrudes through a hole made in the cranium **7**, but not through the dura **8**. Again, this may protect the device from harm and reduce irritation of the scalp. Additionally, such an architecture reduces the number of incisions in the cranium as a separate orifice for the lead **10** is not required. The coil may still rest on the outside of the cranium (FIG. **20A**) or under the cranium (FIG. **20B**) as required.

**[0181]** Although specific combinations of package, coil, and thin film lead, and/or penetrating array location are shown in FIGS. **2**, **19** and **20**, it is understood that these architectures are not limiting in any sense and that any permutation of combination of these architectures is also disclosed in this invention. Similarly, it is understood that there is no reason to limit the implant architecture to containing only one of a coil, package, and thin film lead. The present invention may consist of any number of those components disposed at different positions in the head as previously described. An example is provided in FIG. **21**. In this embodiment there are 2 packages **14** and **15**, one, a primary controller, which houses electronics for the implant, and another secondary package which primarily contains a battery but may alternatively contain some additional electronics or may only contain additional electronics. Two thin film leads **10** are attached to the primary controller. One of these leads may penetrate the brain while the other sits on a surface, or both may penetrate or both may sit on the surface. Two coils **16** and **17** are attached to the primary controller perhaps for redundancy or perhaps to permit easier collocation of the external communication unit.

**[0182]** It is a feature of this embodiment that the secondary package is connected to the primary controller using the same polymer based cable structure as that employed for the two thin film leads **350**. This is shown more clearly in FIG. **21C**, which indicates that the entire polymer based thin film structure, including both leads all interconnections required for multiple packages and coils, may be provided in one piece. Alternatively, it may be desirable to have the secondary package attach to the primary controller using a connector that can be connected or unconnected in situ. An example of such a connector **351** is shown in FIG. **21C**. Here, wire leads from the secondary package plug into a connector on the primary controller facilitating, potentially, easy replacement of the secondary feature (say a battery). Other connector embodiments will be readily apparent to one of normal skill in the art. The primary feature of such a connector is that it provides for minimal electrical current leakage (at least less than 1 uA/s, more preferably less than 0.1 uA/s or even 0.01 uA/s).

**[0183]** Although FIG. **21** shows one device architecture it should not be limiting as it may be appreciated that any number of coils, packages, and leads may be used in any combination, and that any polymer based structure(s) used to connect the components do not necessarily need to be manufactured in one integrated unit. As well, the physical locations of the components in and on or under the cranium may also vary.

**[0184]** Similarly, it is an aspect of the present invention that a thin film lead may not be required. Instead multiple electrodes may be formed in the package itself. One such embodiment is shown in FIG. **20C**, where the package extends through the cranium and dura and makes contact with the surface of the brain with multiple electrodes.

**[0185]** It is also an aspect of the present invention that the coil need not be remote from a package but may alternatively be contained in a package.

**[0186]** Another aspect of the present invention includes coating the package(s), and/or coil(s), and or thin film lead(s) with materials that enhance biocompatibility, resistance to corrosion, tissue growth, neural tissue growth, and or coatings that deliver pharmaceutical agents that enhance device function or disease treatment.

**[0187]** Another embodiment of the present invention includes the addition of one or more integrated circuits or chips that are coated in a biocompatible and hermetic thin film package of the type disclosed in U.S. Pat. Nos. 7,127,286, 7,190,051, and patent application Ser. Nos. 11/406,743, 11/343,170, incorporated herein by reference. A chip or chips coated in such a way enables new device architectures that benefit from a reduction in the size of the device and/or a further increase in the number of electrodes.

**[0188]** Examples of these new architectures are shown in FIG. 22. In FIG. 22A, a coated chip 49 (a demultiplexer, for example) is added to the thin film lead near the array. In this way, the traces in the lead can be used to address more than a single electrode. For example, if the ceramic feedthrough permits at most 68 vias 16 but perhaps 480 electrodes are desired for the device, then 60 traces (along with some power and control lines) may be routed to the chip 49 which can perform 1:8 demultiplexing of the input signals to high density electrode outputs also located on the chip. An example is shown in FIG. 22D and E (although 8:1 demultiplexing is not necessarily maintained in the drawing). It should be obvious to one of reasonable skill in the art that more than one coated chip may be used in such an architecture, and that coated discrete electronic components may also be employed. In another embodiment, the demultiplexing function may be moved to inside one or more of the packages. In this scenario, the ceramic may contain enough feedthroughs to address each electrode individually, but the electronics may not have enough drivers to drive current through each electrode independently. In this case the demultiplexing may occur within in the package.

**[0189]** Alternatively, it may be possible to place all of the required electrical circuitry on a single coated chip or multiple coated chips with or without demultiplexing such that the chip(s) can be placed under the cranium and or dura as shown in FIG. 22B. In this case the chip is shown deep within the brain but it may be appreciated by anyone skilled in the art that the chip may also be on a surface of the brain or dura. In this case only data and or power from an implanted coil and/or battery located on the cranium (as shown), in the cranium, or under the cranium need be routed to the chip along a thin film lead. Alternatively, even the coil may be integrated into the coated chip such that no additional component is required, as shown in FIG. 22C. In such a scenario it may or may not be desirable to have the chip interconnected to a polymer lead of similar size as the chip, such lead containing the electrodes that interface with the tissue. This step may be required to tailor the physical properties of the tissue interface or to permit manufacturing processes for the electrodes (for example electro-plating of platinum gray) that might not otherwise be possible if the electrodes were placed directly on the chip.

**[0190]** Although specific examples of numbers and locations of coils, packages, leads, and chips are shown in the drawings, it is implied that any combination of numbers of components and their locations that are reasonable extensions from this invention are also included.

**[0191]** In one other embodiment, a package of the type already disclosed in FIG. 3 but of very low profile, preferably less than 2 mm, or 1.5 mm, or even 1 mm in height, may be used to encase and protect the chip(s) (and possibly other components) rather than a thin film package. Again, several such packages implanted beneath the dura on the surface of or deep within the brain may also be desirable.

**[0192]** Referring to FIG. 24, specific target sensing or stimulation areas of the brain for the system described include the sensory and motor areas.

**[0193]** This application is a cortically driven motor prosthesis: electrodes implanted on or in a motor strip, which, when activated, cause involuntary movements in the subject. The implant provides control for an external robotic prosthesis—an implant with recording electrodes on or in a pre-motor (forward of motor strip) or motor strip, which sends data wirelessly to an external processor which drives a robotic limb (arm, hand, leg, foot) or stimulates muscles in a deinnervated arm, hand, leg, foot, face, tongue, etc.

**[0194]** Motor signal neural recorder and a somatosensory prosthesis providing motor control and external or implantable sensors that respond to

**[0195]** 1. Pressure

**[0196]** 2. Temperature (heat or cold) or

**[0197]** 3. Harmful stimuli such as sharp objects which send data to a processor that then sends the information to an implanted prosthesis with stimulating electrodes on or in the somatosensory strip.

**[0198]** The flexible circuit 1 is a made by the following process. First, a layer of polymer (such as polyimide, fluoro-polymers, silicone or other polymers) is applied to a support substrate (not part of the array) such as glass. Layers may be applied by spinning, meniscus coating, casting, sputtering, or other physical or chemical vapor deposition, or similar process. Subsequently, a metal layer is applied to the polymer. The metal is patterned by photolithographic process. Preferably, a photo-resist is applied and patterned by photolithography followed by a wet etch of the unprotected metal. Alternatively, the metal can be patterned by lift-off technique, laser ablation or direct write techniques.

**[0199]** It is advantageous to make this metal thicker at the electrode and bond pad to improve electrical continuity. This can be accomplished through any of the above methods or electroplating. Then, the top layer of polymer is applied over the metal. Openings in the top layer for electrical contact to the electronics package 14 and the electrodes may be accomplished by laser ablation or reactive ion etching (RIE) or photolithography and wet etch. Making the electrode openings in the top layer smaller than the electrodes promotes adhesion by avoiding delamination around the electrode edges.

**[0200]** The pressure applied against the neural tissue by the flexible circuit electrode array is critical. Too little pressure causes increased electrical resistance between the array and the tissue. It should be noted that where the present invention is described in terms of application to the brain, the techniques described are equally applicable to many forms of neural sensing or stimulation. Application to the brain requires a convex spherical curve. Application to the cochlea requires a constant curve in one dimension and a spiral curve in the other. Application to the cerebral cortex requires a concave spherical curve. Cortical recording and stimulation is useful for touch and motor control for limb prostheses.

**[0201]** Common flexible circuit fabrication techniques such as photolithography generally require that a flexible circuit electrode array be made flat. Since the brain is spherical, a flat array will necessarily apply more pressure near its edges, than at its center. With most polymers, it is possible to curve them when heated in a mold. By applying the right amount of heat to a completed array, a curve can be

induced that matches the curve of the brain. To minimize warping, it is often advantageous to repeatedly heat the flexible circuit in multiple molds, each with a decreasing radius. FIG. 25 illustrates a series of molds according to the preferred embodiment. Since the flexible circuit will maintain a constant length, the curvature must be slowly increased along that length. As the curvature 430 decreases in successive molds (FIGS. 25A-25E), the straight line length between ends 432 and 434 must decrease to keep the length along the curvature 430 constant, where mold 25E approximates the curvature of the brain or other desired neural tissue. The molds provide a further opening 436 for the flexible circuit cable 10 of the array to exit the mold without excessive curvature.

[0202] It should be noted that suitable polymers include thermoplastic materials and thermoset materials. While a thermoplastic material will provide some stretch when heated, a thermoset material will not. The successive molds are, therefore, advantageous only with a thermoplastic material. A thermoset material works as well in a single mold as it will with successive smaller molds. It should be noted that, particularly with a thermoset material, excessive curvature in three dimensions will cause the polymer material to wrinkle at the edges. This can cause damage to both the array and the brain. Hence, the amount of curvature is a compromise between the desired curvature, array surface area, and the properties of the material.

[0203] Referring to FIG. 26, the edges of the polymer layers are often sharp. There is a risk that the sharp edges of a flexible circuit will cut into delicate tissue. It is advantageous to add a soft material, such as silicone, to the edges of a flexible circuit electrode array to round the edges and protect the brain. Silicone around the entire edge is preferable, but may make the flexible circuit less flexible. So, another embodiment, as depicted in FIG. 26, has discrete silicone bumpers or ribs to hold the edge of the flexible circuit electrode array away from the brain tissue. Curvature 440 fits against the neural tissue to be stimulated, in this case the brain. The leading edge 444 is most likely to cause damage and is therefore fit with molded silicone bumper. Also, edge 446, where the array lifts off the brain, can cause damage and should be fit with a bumper. Any space along the side edges of curvature 440 may cause damage and may be fit with bumpers as well. It is also possible for the flexible circuit cable 10 of the electrode array to contact the brain. It is, therefore, advantageous to add periodic bumpers along the flexible circuit cable 10.

[0204] FIG. 27 depicts a further embodiment of the part of the prosthesis shown in FIG. 26, with a fold A between the flexible circuit electrode array 333 and the flexible circuit cable 10. The angle in the fold A also called ankle has an angle of 1°-180°, preferably 80°-120°. The fold A may be advantageous in reducing tension and enabling a more effective attachment of the flexible circuit electrode array.

[0205] FIG. 28 shows the flexible circuit electrode array prior to folding and attaching the array to the electronics package. At one end of the flexible circuit cable 10 is an interconnection pad 52 for connection to the electronics package. At the other end of the flexible circuit cable 10 is the flexible circuit electrode array 333. Further, an attachment point 54 is provided near the flexible circuit electrode array 333. A tack (not shown) may be placed through the attachment point 54 to hold the flexible circuit electrode array 333 to tissue. A stress relief 55 is provided surrounding

the attachment point 54. The stress relief 55 may be made of a softer polymer than the flexible circuit, or it may include cutouts or thinning of the polymer to reduce the stress transmitted from the tack to the flexible circuit electrode array 333. The flexible circuit cable 10 is formed in a dog leg pattern so that when it is folded at fold 48 it effectively forms a straight flexible circuit cable 10 with a narrower portion at the fold 48.

[0206] FIG. 29 shows the flexible circuit electrode array after the flexible circuit cable 10 is folded at the fold 48 to form a narrowed section. The flexible circuit cable 10 may include a twist or tube shape as well. With a brain prosthesis as shown in FIG. 1, the bond pad 52 for connection to the electronics package 14 and the flexible circuit electrode array 333 are on opposite sides of the flexible circuit. This requires patterning, in some manner, both the base polymer layer and the top polymer layer. By folding the flexible circuit cable 10 of the flexible circuit electrode array 333, the openings for the bond pad 52 and the electrodes are on the top polymer layer, and only the top polymer layer needs to be patterned.

[0207] Further, it is advantageous to provide a suture tab 56 in the flexible circuit body near the electronics package to prevent any movement in the electronics package from being transmitted to the flexible circuit electrode array 333. Alternatively, a segment of the flexible circuit cable 10 can be reinforced to permit it to be secured directly with a suture.

[0208] An alternative to the bumpers described in FIG. 26, is a skirt of silicone or other pliable material as shown in FIGS. 31, 32, 33 and 34. A skirt 460 covers the flexible circuit electrode array 333, and extends beyond its edges. It is further advantageous to include wings 462 adjacent to the attachment point 54 to spread any stress of attachment over a larger area of the brain. There are several ways of forming and bonding the skirt 460. The skirt 460 may be directly bonded through surface activation or indirectly bonded using an adhesive.

[0209] Alternatively, a flexible circuit electrode array 333 may be layered using different polymers for each layer. Using too soft of a polymer may allow too much stretch and break the metal traces. Too hard of a polymer may cause damage to delicate neural tissue. Hence a relatively hard polymer, such as a polyimide may be used for the bottom layer and a relatively softer polymer such as a silicone may be used for the top layer including an integral skirt to protect delicate neural tissue. The top layer is the layer closest to the neural tissue.

[0210] The simplest solution is to bond the skirt 460 to the back side (away from the tissue) of the flexible circuit electrode array 333 as shown in FIG. 31. While this is the simplest mechanical solution, sharp edges of the flexible circuit electrode array 333 may contact the delicate tissue. Bonding the skirt to the front side (toward the brain) of the flexible circuit electrode array 333, as shown in FIG. 32, will protect the neural tissue from sharp edges of the flexible circuit electrode array 333. However, a window 462 must be cut in the skirt 460 around the electrodes. Further, it is more difficult to reliably bond the skirt 460 to the flexible circuit electrode array 333 with such a small contact area. This method also creates a space between the electrodes and the brain which will reduce efficiency and broaden the electrical field distribution of each electrode. Broadening the electric field distribution will limit the possible resolution of the flexible circuit electrode array 333.

[0211] FIG. 33 shows another structure where the skirt 460 is bonded to the back side of the flexible circuit electrode array 333, but curves around any sharp edges of the flexible circuit electrode array 333 to protect the brain. This gives a strong bond and protects the flexible circuit electrode array 333 edges. Because it is bonded to the back side and molded around the edges, rather than bonded to the front side, of the flexible circuit electrode array 333, the portion extending beyond the front side of the flexible circuit electrode array 333 can be much smaller. This limits any additional spacing between the electrodes and the tissue.

[0212] FIG. 34 shows a flexible circuit electrode array 333 similar to FIG. 33, with the skirt 460, flush with the front side of the flexible circuit electrode array 333 rather than extending beyond the front side. While this is more difficult to manufacture, it does not lift the electrodes off the brain surface as with the array in FIG. 32. It should be noted that FIGS. 31, 33, and 34 show skirt 460 material along the back of the flexible circuit electrode array 333 that is not necessary other than for bonding purposes. If there is sufficient bond with the flexible circuit electrode array 333, it may advantageous to thin or remove portions of the skirt 460 material for weight reduction.

[0213] Referring to FIG. 35, the flexible circuit electrode array 333 is manufactured in layers. A base layer of polymer 70 is laid down, commonly by some form of chemical vapor deposition, spinning, meniscus coating, or casting. A layer of metal 72 (preferably platinum) is applied to the polymer base layer 70 and patterned to create electrodes 74 and traces for those electrodes. Patterning is commonly done by photolithographic methods. The electrodes 74 may be built up by electroplating or similar method to increase the surface area of the electrode 74 and to allow for some reduction in the electrodes 74 over time. Similar plating may also be applied to the bond pads 52 (FIGS. 28-30). A top polymer layer 76 is applied over the metal layer 72 and patterned to leave openings for the electrodes 74, or openings are created later by means such as laser ablation. It is advantageous to allow an overlap of the top polymer layer 76 over the electrodes 74 to promote better adhesion between the layers, and to avoid increased electrode reduction along their edges. The overlapping top layer promotes adhesion by forming a clamp to hold the metal electrode between the two polymer layers. Alternatively, multiple alternating layers of metal and polymer may be applied to obtain more metal traces within a given width.

[0214] FIG. 36 depicts the flexible circuit array 10 before it is folded and attached to the implanted portion containing an additional fold A between the flexible electrode array 10 and the flexible cable 10. The angle in the fold A also called ankle has an angle of 1°-180°, preferably 80°-120°.

[0215] FIG. 37 depicts the flexible circuit array 10 containing an additional fold A between the flexible electrode array 10 and the flexible cable 10. The flexible circuit array as shown in FIGS. 28 and 36 differ by the fold A from each other.

[0216] FIG. 38 depicts a flexible circuit array of FIG. 37 with a protective skirt 460 and containing an additional fold A between the flexible electrode array and the flexible cable. The flexible circuit array as shown in FIGS. 30 and 38 differ by the fold A from each other.

[0217] FIG. 41 depicts a top view of a flexible circuit array and flexible circuit cable as shown in FIGS. 30, 38, 39, and 40, wherein the array in FIG. 41 contains a slit 80 along the length axis.

[0218] FIG. 42 depicts a skirt of silicone or other pliable material as shown in FIGS. 30 to 34. A skirt 460 covers the flexible circuit electrode array 333, and extends beyond its edges. In this embodiment of the present invention, the flexible circuit electrode array contains a slit 80 along the length axis. Further, according to this embodiment, the skirt of silicone or other pliable material contains preferably at least two attachment points 81, and stress relieves 82 are provided surrounding the attachment points 81. The attachment points 81 are located preferably on the skirt 460 outside the flexible circuit electrode 333 and are positioned apart as far as possible from each other. The secondary tack 81 is far enough away from the first tack location 54 not to cause tenting. Furthermore, the polyimide is completely between the two tacks, which also reduces the possibility of tenting. The wings act like external tabs or strain relieves. The multiple tacks prevent rotation of the array. Alternatively, the secondary tack could be placed at an attachment point at 83.

[0219] The stress relief 82 may be made of a softer polymer than the flexible circuit, or it may include cutouts or thinning of the polymer to reduce the stress transmitted from the tack to the flexible circuit electrode array 333.

[0220] FIG. 43 depicts a flexible circuit array 333 with a protective skirt 460 bonded to the back side of the flexible circuit array 333 with a progressively decreasing radius and/or decreasing thickness toward the edges.

[0221] FIG. 44 depicts a flexible circuit array 333 with a protective skirt 460 bonded to the front side of the flexible circuit array 333 with a progressively decreasing radius and/or decreasing thickness toward the edges.

[0222] FIG. 45 depicts a flexible circuit array 333 with a protective skirt 460 bonded to the back side of the flexible circuit array 333 and molded around the edges of the flexible circuit array with a progressively decreasing radius and/or decreasing thickness toward the edges.

[0223] FIG. 46 depicts a flexible circuit array 333 with a protective skirt 460 bonded to the back side of the flexible circuit array 333 and molded around the edges of the flexible circuit array and flush with the front side of the array with a progressively decreasing radius and/or decreasing thickness toward the edges.

[0224] FIG. 47 depicts a side view of the array with a skirt 460 containing a grooved and rippled pad 56A instead of a suture tab 56. This pad 56A has the advantage of capturing a mattress suture 57. A mattress suture 57 has the advantage of holding the groove or rippled pad 56A in two places as shown in FIG. 48. Each suture 57 is fixed on the tissue on two places 59. A mattress suture 57 on a grooved or rippled mattress 56A therefore provides better stability.

[0225] FIG. 49 depicts a flexible circuit array 333 with a protective skirt 460 bonded to the front side of the flexible circuit array 333 with individual electrode 13 windows and with material, preferably silicone, between the electrodes 13.

[0226] FIG. 50 depicts a flexible circuit array 333 with a protective skirt 460 bonded to the back side of the flexible circuit array 333 and molded around the edges of the flexible

circuit array 333 with individual electrode 13 windows and with material, preferably silicone, between the electrodes 13.

[0227] FIGS. 51-56 show several surfaces to be applied to one or both sides of the flexible circuit array cable. The surfaces are thin films containing a soft polymer, preferably silicone. FIG. 51 shows a flange 15: A flange 15 can be a solid film of material containing silicone added to the surface of the polymer containing polyimide. FIGS. 52-54 show a ladder 15A: A ladder 15A is a flange with material removed from central portions in some shape 19. FIG. 55 shows a skeleton structure 15B. A skeleton 15B is a flange with material removed from perimeter portions in some shape 21. FIG. 56 shows a structure 15C with beads 23 and bumpers 25. A bead 23 is material added to perimeter portions of the polymer cable in some shape without material being added on the central area. A bumper 25 can be an extended or continuous version of the beaded approach. Both approaches are helpful in preventing any possible injury of the tissue by the polymer.

[0228] FIG. 57 depicts the top view of the flexible circuit array 333 being enveloped within an insulating material 11A. The electrode array 333 comprises oval-shaped electrode array body 333, a plurality of electrodes 13 made of a conductive material, such as platinum or one of its alloys, but that can be made of any conductive biocompatible material such as iridium, iridium oxide or titanium nitride. The electrode array 333 is enveloped within an insulating material 11A that is preferably silicone. "Oval-shaped" electrode array body means that the body may approximate either a square or a rectangle shape, but where the corners are rounded. The material body 11A is made of a soft material that is compatible with the electrode array body 333. In a preferred embodiment the body 11A made of silicone having hardness of about 50 or less on the Shore A scale as measured with a durometer. In an alternate embodiment the hardness is about 25 or less on the Shore A scale as measured with a durometer.

[0229] FIG. 58 depicts a cross-sectional view of the flexible circuit array 333 being enveloped within an insulating material 11A. It shows how the edges of the material body 11A are lifted off due to the contracted radius at the edges. The electrode array 333 preferably also contains a fold A between the cable 10 and the electrode array 333. The angle of the fold A secures a relief of the implanted material.

[0230] FIG. 59 depicts a cross-sectional view of the flexible circuit array 333 being enveloped within an insulating material 11A with open electrodes 13 and the material 11A between the electrodes 13.

[0231] FIG. 60 depicts a cross-sectional view of the flexible circuit array 333 being enveloped within an insulating material 11A with open electrodes 13. This is another embodiment wherein the electrodes 13 are not separated by the material 11A but the material 11A is extended.

[0232] FIG. 61 depicts a cross-sectional view of the flexible circuit array 333 being enveloped within an insulating material 11A with electrodes 13 on the surface of the material 11. This is a further embodiment with the electrode 13 on the surface of the material 11A, preferably silicone. The embodiments shown in FIGS. 59, 60, and 61 show a preferred body 11A containing silicone with the edges being lifted off from the tissue due to contracted radius of the silicone body 11A at the edges.

[0233] FIG. 62 shows the electrode array 333 and the electrodes 13 enveloped by the polymer material, preferably silicone 11A in intimate contact with the tissue B.

[0234] The electrode array 333 embedded in or enveloped by the polymer material, preferably silicone 11A, can be preferably produced through the following steps. The soft polymer material which contains silicone is molded into the designed shape and partially hardened. The electrode array 333 which preferably contains polyimide is introduced and positioned in the partially hardened soft polymer containing silicone. Finally, the soft polymer 11A containing silicone is fully hardened in the designed shape enveloping the electrode array 333. The polymer body 11A has a shape with a decreasing radius at the edges so that the edges of the body 11A lift off from the brain B.

[0235] Referring to FIGS. 63 and 64, small holes are provided on the hard polymer and subsequently soft polymer containing PDMS is provided on the hard polymer. This way a partial or entire coating or a soft skirt at the edge is provided by a soft polymer on a hard polymer. The holes provide a stronger mechanical bond between the hard and soft polymer as the soft polymer bonds to itself through the holes.

[0236] The hard polymer contains polyimide, polyamide, LCP, Peek, Polypropylene, Polyethylene, Paralyne or mixtures or copolymers or block copolymers thereof. The soft polymer contains at least one PDMS or silicone.

[0237] FIG. 66 shows a cross-sectional view of a polyimide array coated with PDMS. The cross-section shows two polyimide layer embedding Pt thin film seed layer and openings for Pt electrodes and bond pads. The electrodes can be Pt gray or other metals as electrodes, such as Pt, Ir, IrOx, Pd, Au, TiN, Ru, Ti, alloys, conducting polymers or layer thereof. The structure can be obtained in known procedures as described in US Patent Applications Nos. 2006/0247,754, 2006/0259,112, and 2007/0265,665, the entire content of which is incorporated herein as reference. The polyimide array is coated with a soft polymer, which contains PDMS.

[0238] The inventors have found that arrays containing only PDMS show metal trace breakage and/or metal trace/PDMS delaminating. Arrays containing polyimide only have edges which are too sharp and may not be biocompatible. Some pinholes or defects on the polyimide layer may cause leakage and corroding of traces.

[0239] One way to minimize such problems is to add a PDMS flange (skirt) to cover the edge of the array. During PDMS skirt attachment, some Pt gray electrodes may be covered which is not desired. Within the skirt windows, polyimide surface still may be exposed to the brain. A useful approach is to make a thinner polyimide array as the center piece, the core layer, and to coat the entire array with a thin layer of PDMS; and then open up only the electrode sites for Pt gray plating. This way the electrodes are not partially or entirely covered by PDMS. Pt gray plating is described in U.S. Pat. No. 6,974,533, the content of which is incorporated herein as reference.

[0240] The new flexible array is partially covered by PDMS or has no exposure of polyimide and is a virtual PDMS array with a polyimide center core layer.

[0241] The PDMS coated array eliminates the problem of undesired PDMS coverage on Pt gray electrodes because the Pt gray plating process takes place after the PDMS coating is accomplished.

[0242] The polyimide layer can be reduced from 6  $\mu\text{m}$  to 3  $\mu\text{m}$  due to the protection of the PDMS layers. The PDMS top coating can be 5  $\mu\text{m}$  to 20  $\mu\text{m}$  thick. The plated Pt gray electrode is slightly recessed. This helps to improve current distribution and provide benefits for clinical stimulation.

[0243] To increase the adhesion of PDMS to Polyimide, some small holes on the polyimide layer (not only on the edges, but also in the centers and around electrodes) can be provided to achieve anchors for the PDMS as shown in FIGS. 63 and 64.

[0244] The center piece material can contain other polymers than polyimide such as polyamide, LCP, Peek, Polypropylene, Polyethylene, Paralyne or mixtures or copolymers or block copolymer thereof. Parylene, LCP or other materials can also be used for the outer protection layers.

[0245] FIG. 66 shows a sequence of steps 1 to 8 for coating a polyimide electrode with PDMS. The sequence of steps is as follows:

[0246] 1. A first PDMS layer having a thickness of 5  $\mu\text{m}$  to 20  $\mu\text{m}$  is provided;

[0247] 2. A first polyimide layer having a thickness of 2  $\mu\text{m}$  to 4  $\mu\text{m}$  is provided on the PDMS layer;

[0248] 3. A Pt thin film having a thickness of 0.5  $\mu\text{m}$  to 1.5  $\mu\text{m}$  is provided on the first polyimide layer (a very thin layer of Ti or Cr of 500-5000 angstrom can be deposited before and after this Pt thin-film deposition as an adhesion layer to promote good adhesion of Pt to polyimide);

[0249] 4. A second polyimide layer having a thickness of 2  $\mu\text{m}$  to 4  $\mu\text{m}$  is provided on the Pt thin film;

[0250] 5. Holes are provided in the second polyimide layer for bond pads and electrodes by photoresist patterning or dry or wet etch off technology;

[0251] 6. A second PDMS layer having a thickness of 5  $\mu\text{m}$  to 20  $\mu\text{m}$  is provided on the second polyimide layer;

[0252] 7. Holes are provided in the second PDMS layer for bond pads and electrodes by photoresist patterning or dry or wet etch off technology;

[0253] 8. Electrodes are prepared in the provided holes by Pt gray or other metals.

[0254] FIG. 67 shows a sequence of steps 1 to 7 for coating a polyimide electrode with PDMS. The sequence of steps is as follows:

[0255] 1. A first PDMS layer having a thickness of 5  $\mu\text{m}$  to 20  $\mu\text{m}$  is provided;

[0256] 2. A first polyimide layer having a thickness of 2  $\mu\text{m}$  to 4  $\mu\text{m}$  is provided on the PDMS layer;

[0257] 3. A Pt thin film having a thickness of 0.5  $\mu\text{m}$  to 1.5  $\mu\text{m}$  is provided on the first polyimide layer (A very thin layer of Ti or Cr of 500-5000 angstrom can be deposited before and after this Pt thin-film deposition as an adhesion layer to promote good adhesion of Pt to polyimide);

[0258] 4. A second polyimide layer having a thickness of 2  $\mu\text{m}$  to 4  $\mu\text{m}$  is provided on the Pt thin film;

[0259] 5. A second PDMS layer having a thickness of 5  $\mu\text{m}$  to 20  $\mu\text{m}$  is provided on the second polyimide layer;

[0260] 6. Holes are provided in the second PDMS layer and second polyimide layer for bond pads and electrodes by photoresist patterning or dry or wet etch off technology;

[0261] 7. Electrodes are prepared in the provided holes by Pt gray or other metals.

[0262] In yet another embodiment (FIG. 68), it may be desirable to have both surface electrodes 333 and penetrating electrodes 313 on the same surface of the thin film lead 10 as shown in FIG. 68(A). Although an alternating pattern of surface and penetrating electrodes is shown, it is understood that the invention is not restricted to this pattern and that any pattern is available. Also, there is no requirement that equal numbers of surface and penetrating spike electrodes be employed. FIGS. 68B-D, show methods of attachment of individual spike electrodes 313 to the thin film lead 10 (B) or arrays of spike electrodes 13 to either the package 14 or the thin film lead 10 (C and D). The individual spike electrodes or the spike electrode array is attached to the flexible circuit 10 or the package 14 using a flip-chip bumping process, and epoxy underfilled. In the flip-chip bumping process, bumps containing conductive adhesive placed on the base of individual spike electrodes 313 or the bond pads 92 of the spike electrode arrays 13, and bumps containing conductive adhesive placed on the electronics package 14 or the electrodes 333 of the thin film lead 10 are aligned and cured to build a conductive connection between the components.

[0263] In another embodiment, FIG. 69, it may be desirable to have electrodes on either side of the array. FIG. 69 a shows substantially planar surface electrodes 333 on either side of a thin film lead 10 that contains a single metal routing layer 94, although this single layer may be composed of more than one kind of metal. In this diagram, the electrodes are the same size and routed to either surface in an alternating fashion, but it should be understood that different electrode size and routing schemes could be employed. Similarly, although the electrodes are shown as slightly recessed, it should be understood that they may also be flush with the thin film lead surface or protruding slightly. FIG. 69B shows substantially planar surface electrodes 333 on either side of a thin film lead 10 that contains two metal routing layers 94, although each metal layer may be composed of more than one kind of metal. This arrangement has the advantage of creating higher density arrays on either side of the lead. It should be noted that even more metal layers may be used to increase the routing density and decrease size of the thin film lead and/or array. FIG. 69Cc shows substantially planar surface electrodes 333 on one side of a thin film lead 10 and penetrating electrodes 313 on the other side of a thin film lead that contains two metal routing layers 94, although each metal layer may be composed of more than one kind of metal. Note that the substantially planar electrodes 333 are actually protruding slightly, which is not a requirement. They could also be flush or slightly recessed compared to the thin film lead surface. Also, an array of penetrating electrodes could be attached rather than individual electrodes. FIG. 69D shows substantially planar surface electrodes 333 on one side of a thin film lead 10 and penetrating electrodes 313 on the other side of a thin film lead that contains two metal routing layers 94, although each metal layer may be composed of more than one kind of metal. Note that the substantially planar electrodes 333 differ in size and are actually flush. Additionally, the spike electrodes are of varying length. The figure shows individually attached spike electrodes.

[0264] FIG. 70 illustrates how a flexible array of penetrating electrodes could be formed. In this case, a penetrating spike electrode 313, FIG. 70, illustrates how a flexible array of penetrating electrodes could be formed. The advantage of

a flexible penetrating electrode array is that the exposed electrodes at the end of or on the penetrating electrodes should end up at similar depths. This overcomes a disadvantage of stiff penetrating electrode arrays, which when implanted on a highly curved surface, such as those encountered in the brain, the active electrodes often end up in different functional layers of the brain. Thus, not all of the penetrating electrodes are located in the target region of treatment. In this case (FIG. 68A), a single or multiple penetrating spike electrode(s) 313 is/are inserted through vias in the thin film lead 10. Preferred embodiments employ penetrating electrodes made from platinum, iridium, an alloy of platinum and iridium, activated iridium, tungsten, and titanium nitride. A conductive medium such as conductive epoxy 381 is used to electrically connect the spike electrodes 313 to the conductive metal traces 94. The penetrating electrodes could be made of any conductive and biocompatible medium. When forming such penetrating electrode arrays, the epoxy would be cured and then the portion of the electrodes protruding from the back side of the thin film lead would be covered in a non-conductive medium or layers of non-conductive media 360 chosen from biocompatible polymers including epoxy, silicone, Parylene, and others. Several different penetrating electrode structures may be employed as required.

[0265] FIG. 70A shows two possibilities, a spike electrode and a nail electrode. The latter has advantages in manufacturing (the electrode will not accidentally slip through the via) and in maintaining electrical contact. By covering each electrode individually, the flexibility of the array is maintained.

[0266] FIG. 70B, where the thin film lead 10 generally conforms to a surface of the brain 11 and so the tips of the penetrating electrodes 313, which protrude normal to the local surface of the thin film lead, are not equidistant once implanted in the brain.

[0267] FIG. 70C illustrates that the active electrode area on a penetrating electrode could have different sizes, shapes, and locations along the penetrating shaft. That is, the penetrating conductive electrodes 313 are electrically passivated over some or most of their area 361, and a window is opened in this passivation at the desired stimulation or recording site 362. The passivation of the conductive penetrating electrode may be accomplished through anodization, chemical modification of the surface, or by applying a coating of non-conductive biocompatible materials such as silicone, epoxy, Parylene, and others. The exposed region or active electrode site may be located at the tip of the penetrating electrode or somewhere along the shaft and may be made by standard patterning techniques. The size and shaped of the active electrode are also easily varied.

[0268] FIG. 71 shows an alternative penetrating flexible circuit electrode array. The flexible circuit electrode array 700 separates into penetrating fingers 702 to penetrate different areas of the brain. Further, the penetrating fingers make the flexible circuit electrode array more flexible to better accommodate the cortical tissue. The brain moves with minimal forces. The penetrating fingers 702 remain in better contact with the brain as it moves.

[0269] FIG. 72 shows a hybrid surface and penetrating flexible circuit electrode array. The hybrid array provides penetrating fingers 702 and surface fingers 703. As the system is programmable, each electrode may be used for recording or stimulation.

[0270] FIG. 73 shows an insertion tool for a penetrating flexible circuit electrode array. Since the penetrating fingers 702 are highly flexible, a tool is needed to gently press the penetrating fingers 702 into the cortical tissue. The insertion tool 704 includes spikes 706 designed to mate with the holes of the penetrating fingers 702 and gently press them into the cortical tissue. The inserter tip penetrates a hole in the array tip; the very point of the array is bent back to provide an anchoring action to prevent the array from coming out when the insertion tool is retracted, and to prevent micro-motion while implanted. Alternatively, pockets, recesses or other means can be formed in the penetrating fingers to allow the tool to connect to the array fingers for insertion.

[0271] Referring to FIG. 74, leveraging experience from successfully designing the chronically implantable Argus™ II Retinal Prosthesis, the RCI implant will similarly include a coil, thin film electrode array, and implant electronics housed in a hermetic package. For the RCI, the implant coil is located subcutaneously under the scalp or possibly on the brain or dura and will receive power from an external coil placed over the scalp through inductive coupling.

[0272] The implant power recovery circuit retrieves DC power from the RF power carrier to supply the ASIC. Amplitude modulated data from the AES is sent to the implant at a data rate of 122 kbps. The transceiver on the ASIC chip decodes this telemetry data (referred to as forward telemetry) which carries implant control commands that include electrode selection for each neural sensing channel, gain selection, sampling control, and other safety and diagnostic commands. The forward telemetry also supports CNS electrode stimulation commands for up to 60 electrodes. The Argus II implant ASIC is modified to include 16 neural sensing channels and reliably conveys this information to the AES. The channels each contain a differential neural amplifier that senses sub- $\mu$ V neural signals and a band pass filter for a specified y band of 75-105 Hz. The amplified and band filtered signals from the specified channels are sampled by an ADC without data reduction at a rate up to 480 Hz per channel and with sub- $\mu$ V input resolution. Raw data from the ADC is streamed to the AES directly through a wireless link (referred to as back telemetry) designed with a bandwidth capable of handling the data flow in real time. The back telemetry data words include a header and CRC to ensure bit error detection. The back telemetry employs a Frequency-shift Keying scheme whose carrier frequency is selected to minimize susceptibility to anticipated interfering signals. The ASIC also includes a dedicated channel and a 1 KHz test signal generator for analyzing electrode impedance values and thus determining the health of the electrode array.

[0273] Accordingly, what has been shown is an, improved method of making a hermetic package for implantation in a body. While the invention has been described by means of specific embodiments and applications thereof, it is understood that numerous modifications and variations could be made thereto by those skilled in the art without departing from the spirit and scope of the invention. It is therefore to be understood that within the scope of the claims, the invention may be practiced otherwise than as specifically described herein.

What we claim is:

1. A neural interface system comprising:

an external portion including a processor, telemetry circuit, and external coil, the external coil sending power to, and sending and receiving data to and from, an implanted portion;

the implanted portion including

an internal coil receiving power from, and sending and receiving data to a from the external coil,

a hermetic package,

an electronic circuit within the hermetic package receiving power from the internal coil and sending and receiving data to and from the internal coil,

a differential neural amplifier within the hermetic package,

an analog to digital converter connecting the differential neural amplifier to the electronic circuit,

a driver within the hermetic package connected to the electronic circuit, and

a flexible circuit including at least one stimulating electrode connected to the driver and at least one sensing electrode connected to the differential neural amplifier, the flexible circuit configured to interface with neural tissue of the brain.

2. The neural interface system according to claim 1, further comprising a moisture leakage electronic monitor within the hermetic package.

3. The neural interface system according to claim 1, further comprising a band pass filter connected between the differential neural amplifier and the electronic circuit.

4. The neural interface system according to claim 3, wherein the band pass filter allows frequencies between 75 and 105 hertz.

5. The neural interface system according to claim 1, wherein the data includes control commands including at least one command selected from the group of electrode selection for a neural sensing channel, gain selection, sampling control and other safety and diagnostic commands.

6. The neural interface system according to claim 1, wherein the data includes stimulation data for a stimulation channel.

7. The neural interface system according to claim 1, wherein the analog to digital converter samples at a rate of 480 hertz.

8. The neural interface system according to claim 1, wherein the data includes electrode impedance.

\* \* \* \* \*

专利名称(译)	皮质接口，用于电机信号记录和感觉信号刺激		
公开(公告)号	<a href="#">US20180345019A1</a>	公开(公告)日	2018-12-06
申请号	US16/044379	申请日	2018-07-24
[标]申请(专利权)人(译)	第二视力MEDICAL PRODS		
申请(专利权)人(译)	第二视力医疗产品，INC.		
当前申请(专利权)人(译)	第二视力医疗产品，INC.		
[标]发明人	GREENBERG ROBERT J ZHOU DAVID DAOMIN MACH BRIAN V TALBOT NEIL HAMILTON DAI RONGQING CASTRO RICHARD AGUSTIN MCCLURE KELLY H		
发明人	GREENBERG, ROBERT J. ZHOU, DAVID DAOMIN MACH, BRIAN V. TALBOT, NEIL HAMILTON DAI, RONGQING CASTRO, RICHARD AGUSTIN MCCLURE, KELLY H.		
IPC分类号	A61N1/36 A61B5/00 A61B5/04 A61N1/05 A61N1/375 H05K1/11 H05K1/18		
CPC分类号	A61B5/6868 A61B5/04001 A61N1/0534 A61N1/0539 H01L2224/85399 A61N1/36082 A61N1/375 H05K1/118 H05K1/189 H05K2201/0154 H05K2201/10098 H01L2224/45144 A61N1/0531 H01L2224/48227 H01L2924/3011 A61B5/4064 H01L2224/85099 H01L2224/48465 H01L2224/05599 A61N1/37514 A61N1/37518 H01L2924/00 H01L2924/00014		
优先权	61/486704 2011-05-16 US		
外部链接	<a href="#">Espacenet</a> <a href="#">USPTO</a>		

摘要(译)

本发明包括具有至少一个封装的可植入设备，该封装容纳电子器件，该电子器件通过连接到至少一个封装的至少一个线圈从外部系统发送和接收数据或信号，并且可选地供电，并处理数据，包括记录神经活动，并通过至少一个连接到至少一个包装的多个电极阵列将电脉冲传递到神经组织。本发明或其组件旨在安装在头部中，或颅骨上或颅骨内或硬脑膜上，或脑上或脑中。实施例的变型取决于线圈，封装和阵列相对于头部，颅骨，硬脑膜和脑部的物理位置。本发明的新颖特征包括容纳控制器的小尺寸的可植入封装，提供用于刺激和/或感测和刺激的大量电极，以及制造这种装置的方法。这些特征在神经刺激中具有独特的应用，用于治疗或预防疾病或疾病。

