



(19) **United States**

(12) **Patent Application Publication**
Suzuki

(10) **Pub. No.: US 2018/0024047 A1**
(43) **Pub. Date: Jan. 25, 2018**

(54) **ELASTIC WAVE RECEIVING APPARATUS,
ELASTIC WAVE RECEIVING METHOD,
PHOTOACOUSTIC APPARATUS, AND
PROGRAM**

(71) Applicant: **CANON KABUSHIKI KAISHA,**
Tokyo (JP)

(72) Inventor: **Koichi Suzuki,** Kodaira-shi (JP)

(21) Appl. No.: **15/720,752**

(22) Filed: **Sep. 29, 2017**

Related U.S. Application Data

(62) Division of application No. 13/503,785, filed on Apr. 24, 2012, now Pat. No. 9,823,182, filed as application No. PCT/JP2010/072600 on Dec. 9, 2010.

Foreign Application Priority Data

Dec. 15, 2009 (JP) 2009-284541

Publication Classification

(51) **Int. Cl.**
G01N 21/17 (2006.01)
A61B 5/00 (2006.01)
U.S. Cl.
CPC *G01N 21/1702* (2013.01); *A61B 5/4312*
(2013.01); *A61B 5/6843* (2013.01); *A61B*
5/0091 (2013.01); *A61B 5/0095* (2013.01);
G01N 2021/1706 (2013.01)

(57) **ABSTRACT**

An elastic wave receiving apparatus includes: a probe that receives an elastic wave generated from a subject; a plate-like compression plate that supports the subject and whose surface is scanned by the probe; a motor for driving the probe; a controller that supplies a drive signal to the motor so that the probe moves to a predetermined target position on the compression plate; and a load estimating unit that preliminarily acquires and stores a physical value corresponding to a load generated at the time of scanning the compression plate by the probe. The controller corrects the drive signal so that the probe moves to the target position regardless of the load by using the physical value stored in the load estimating unit.

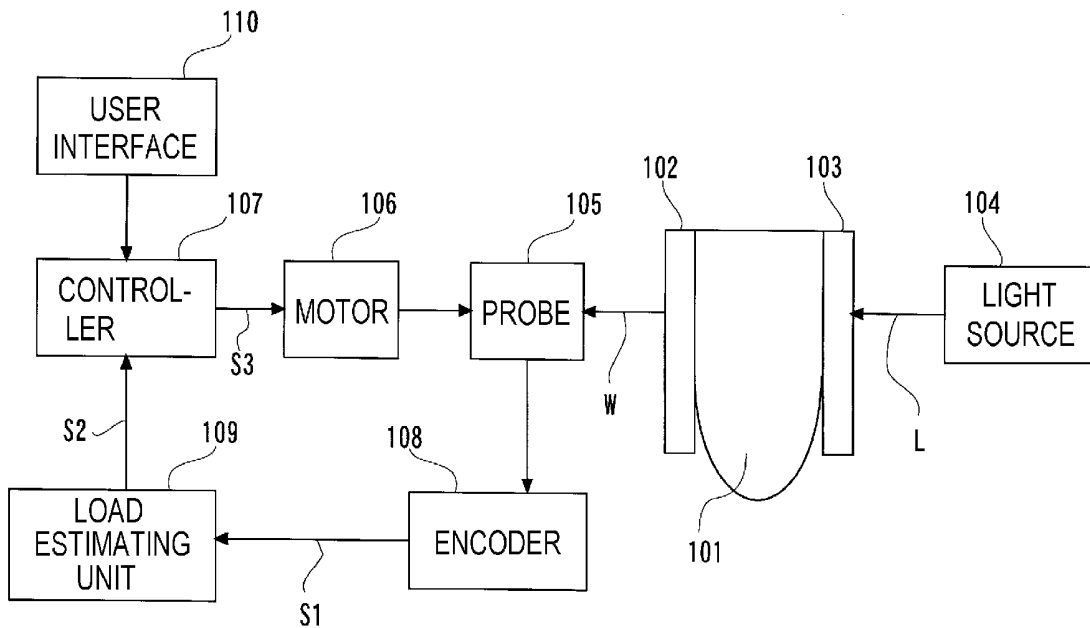

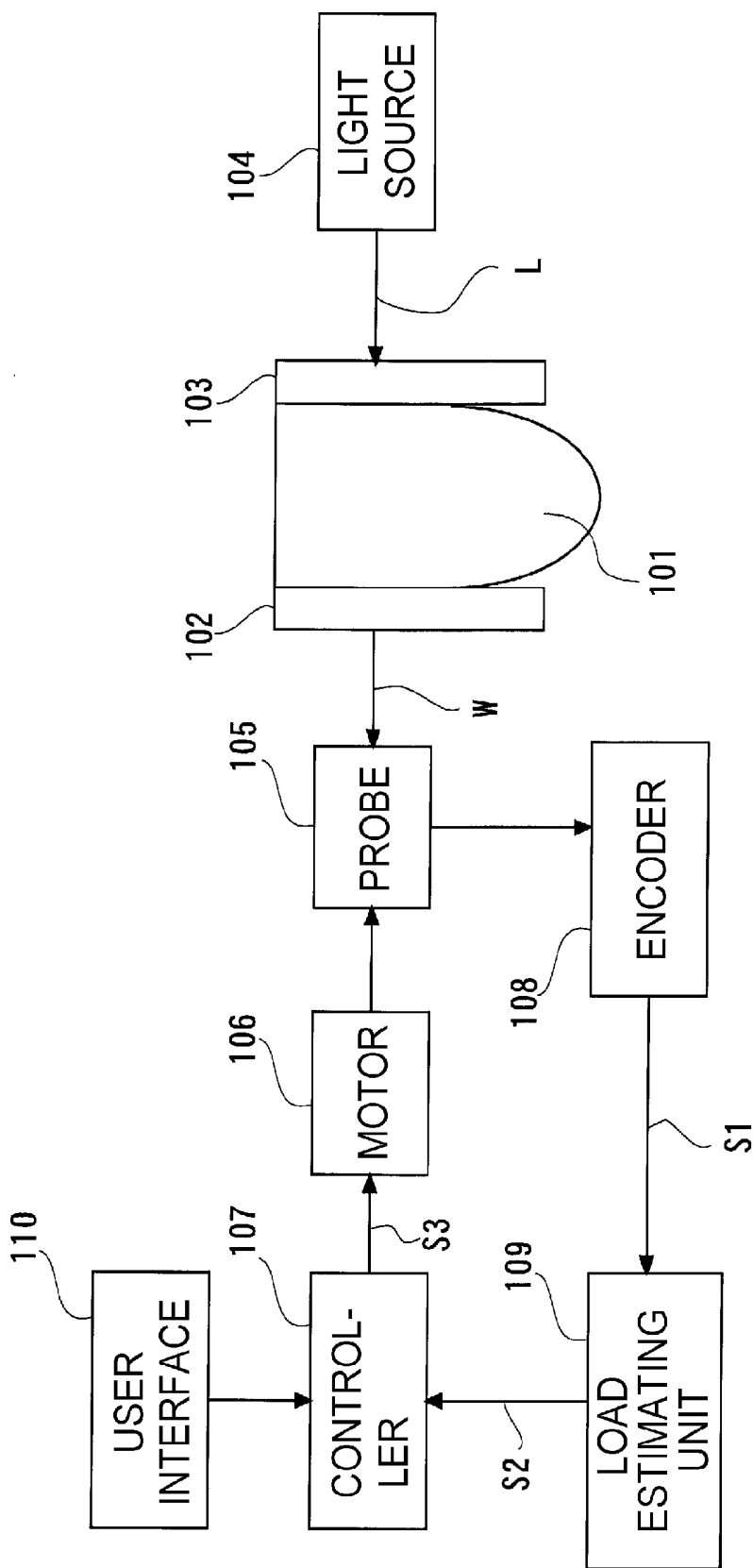

FIG. 1

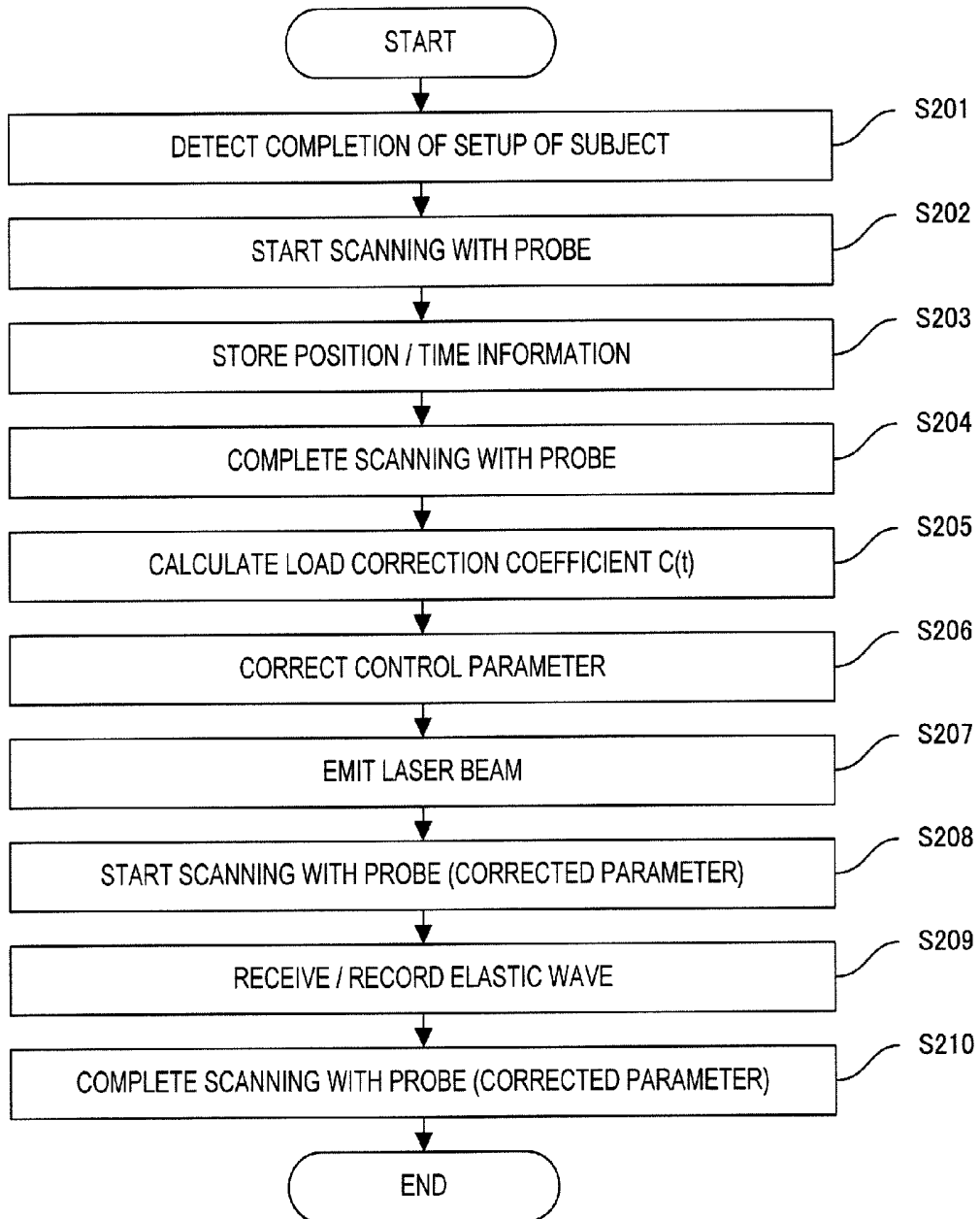

FIG. 2

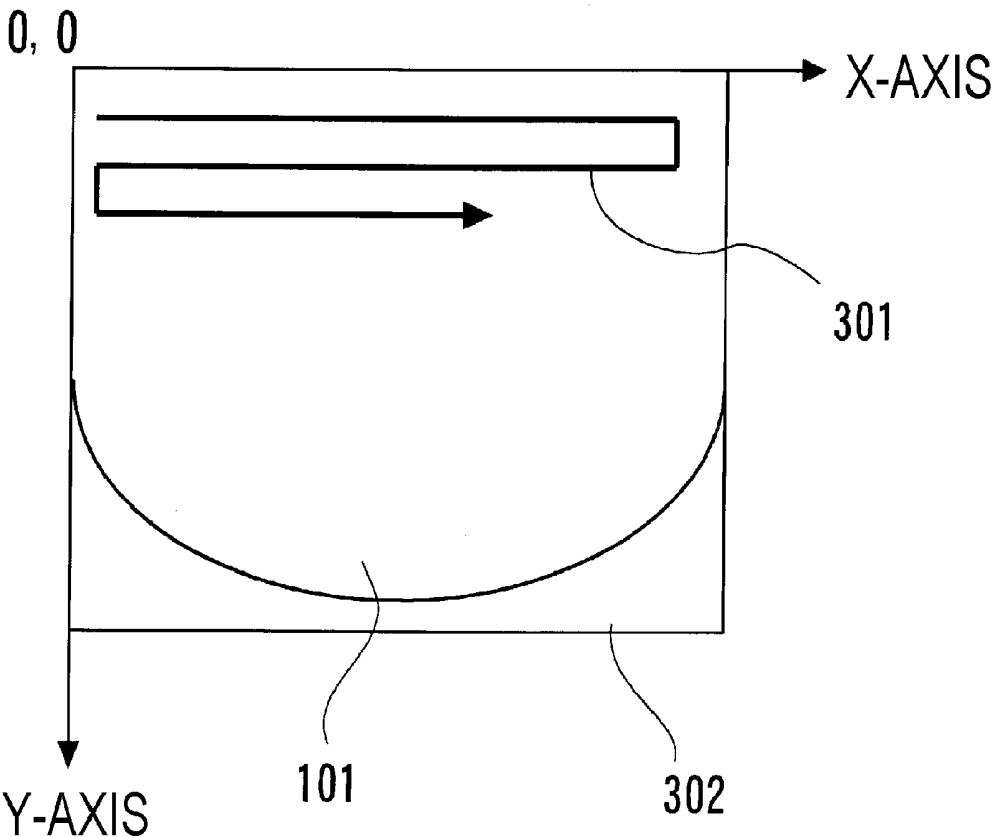

FIG. 3

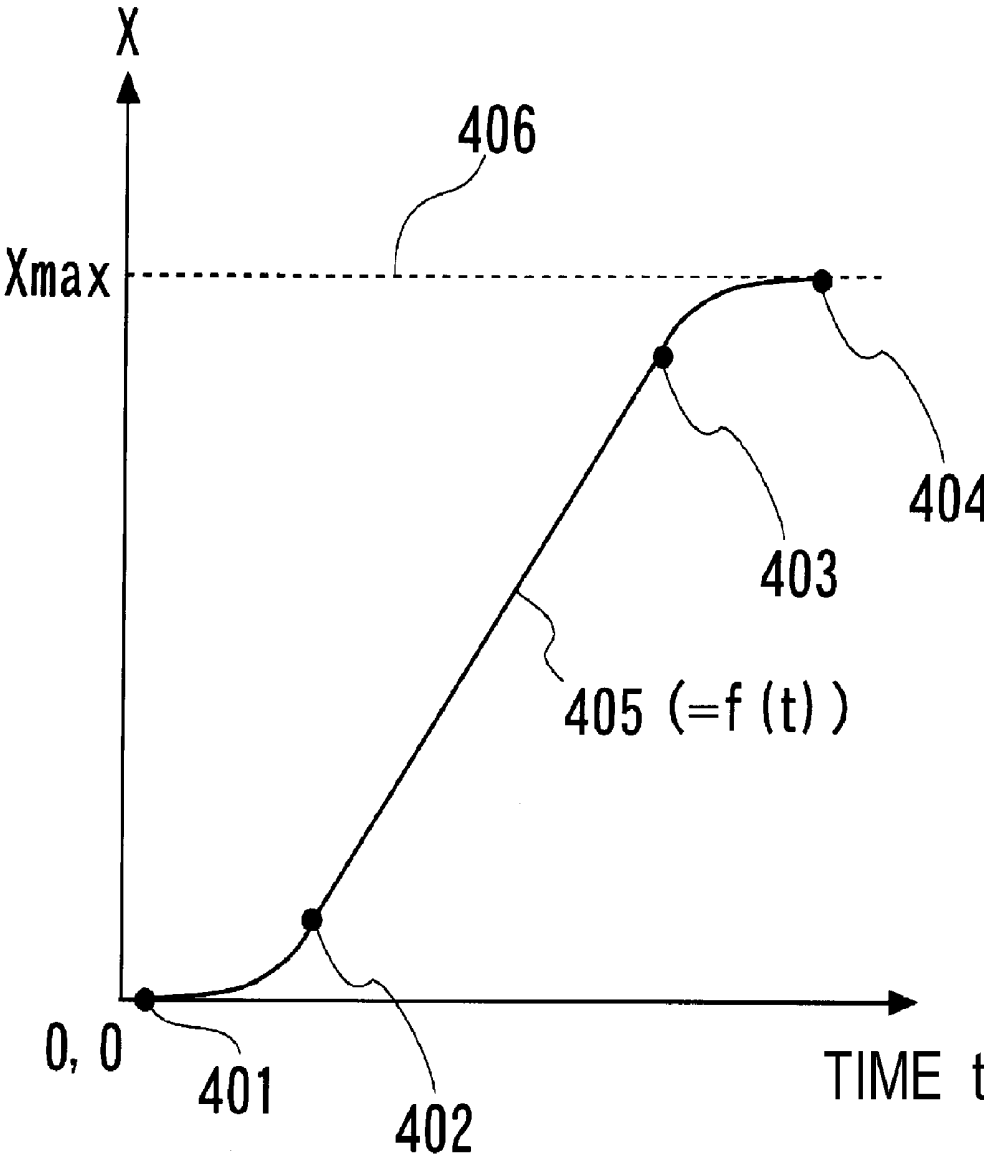

FIG. 4

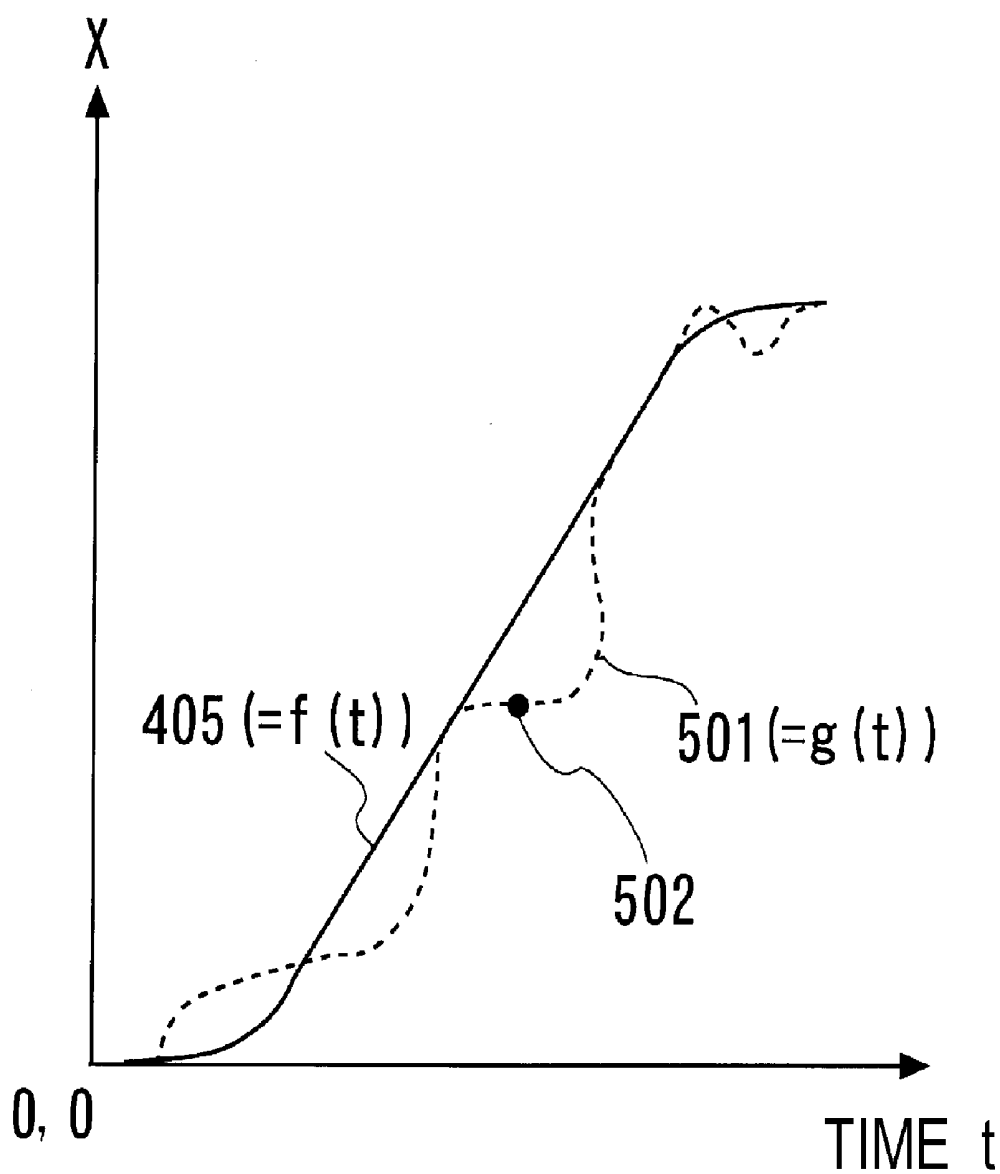

FIG. 5

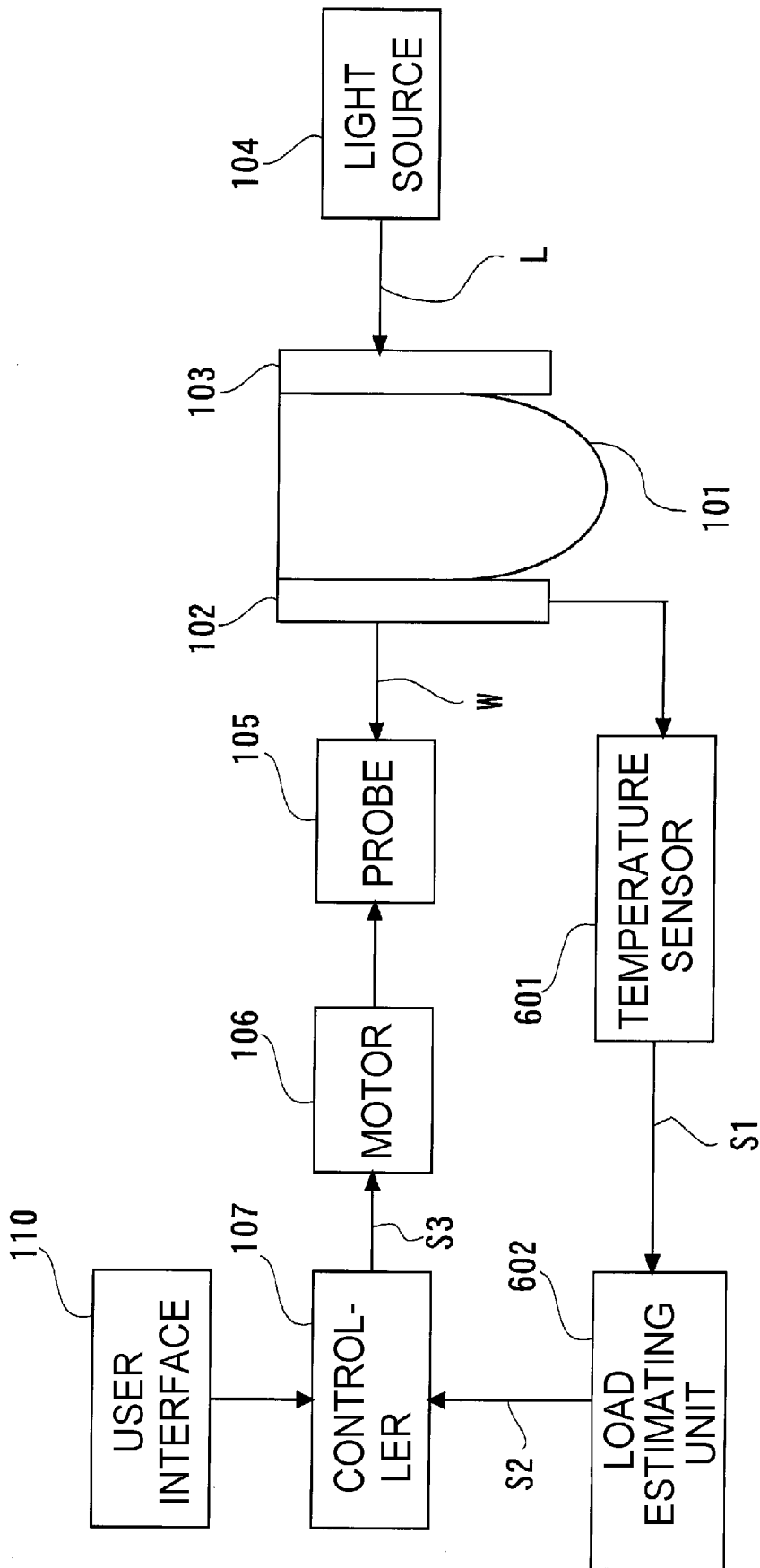

FIG. 6

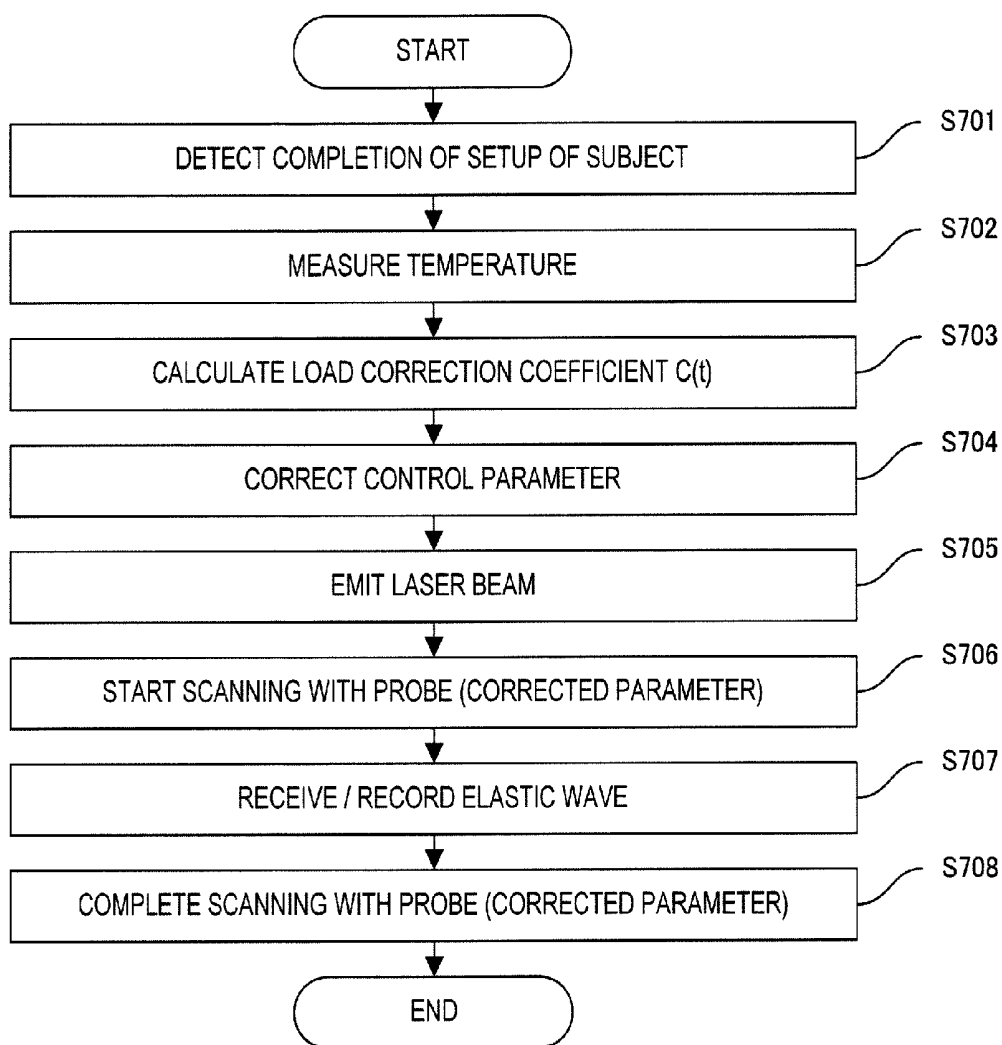

FIG. 7

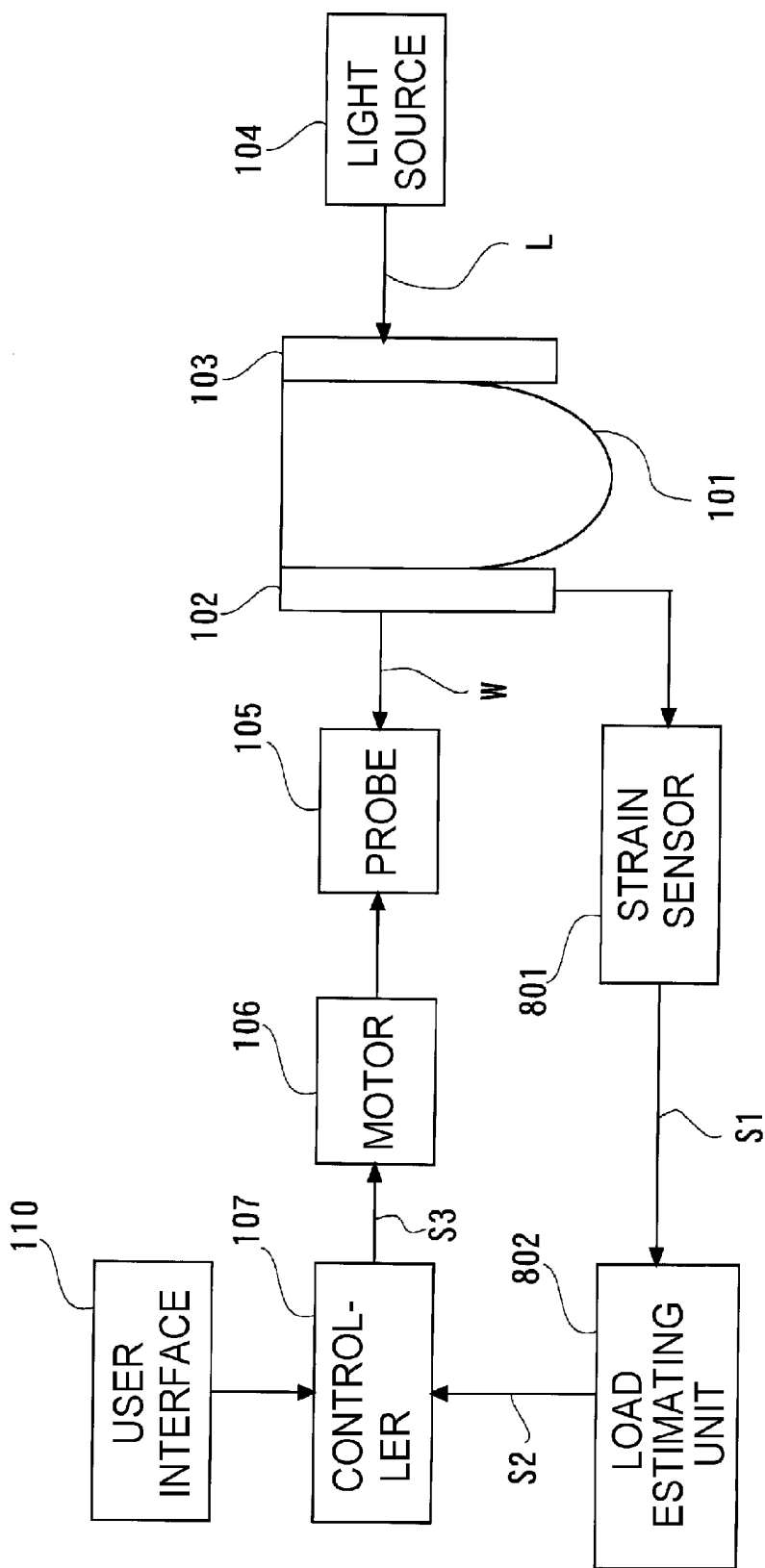

FIG. 8

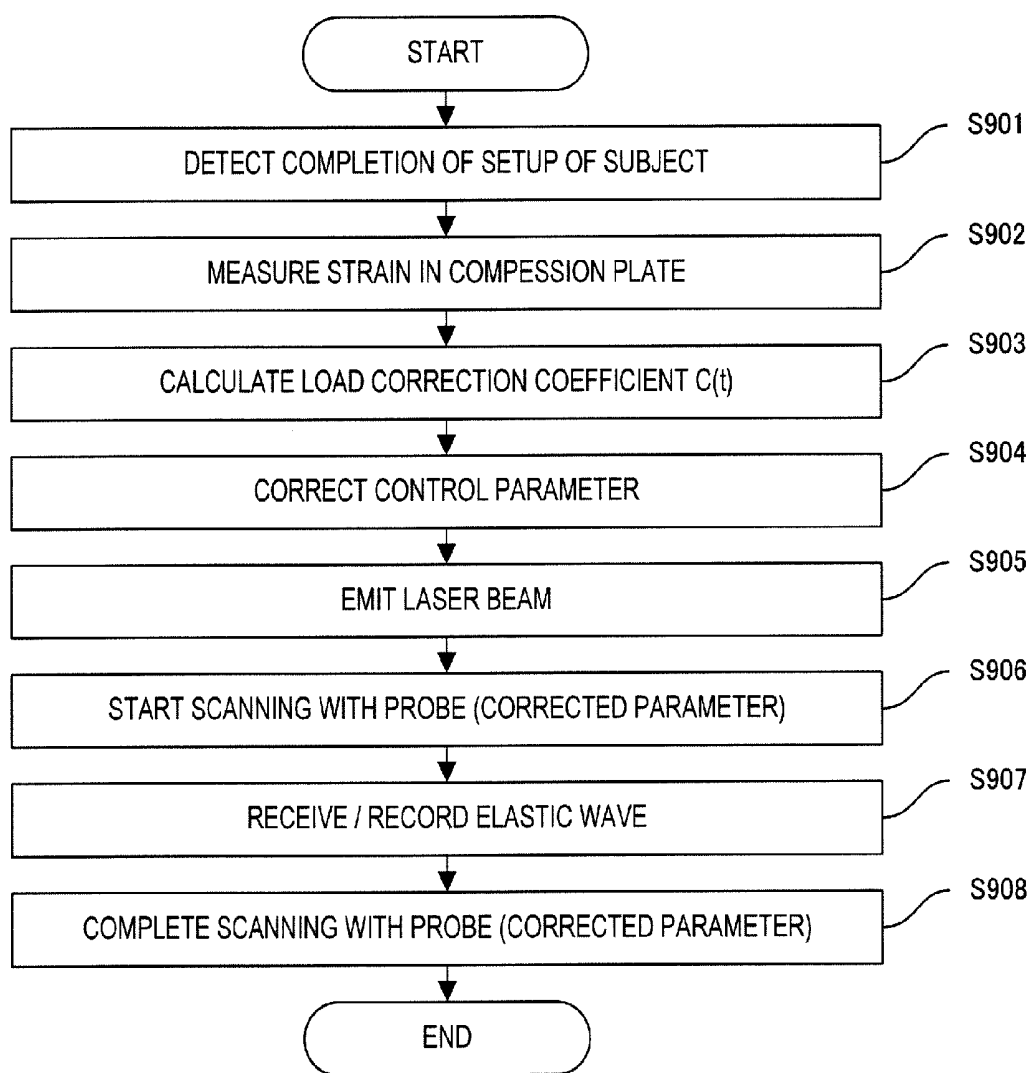

FIG. 9

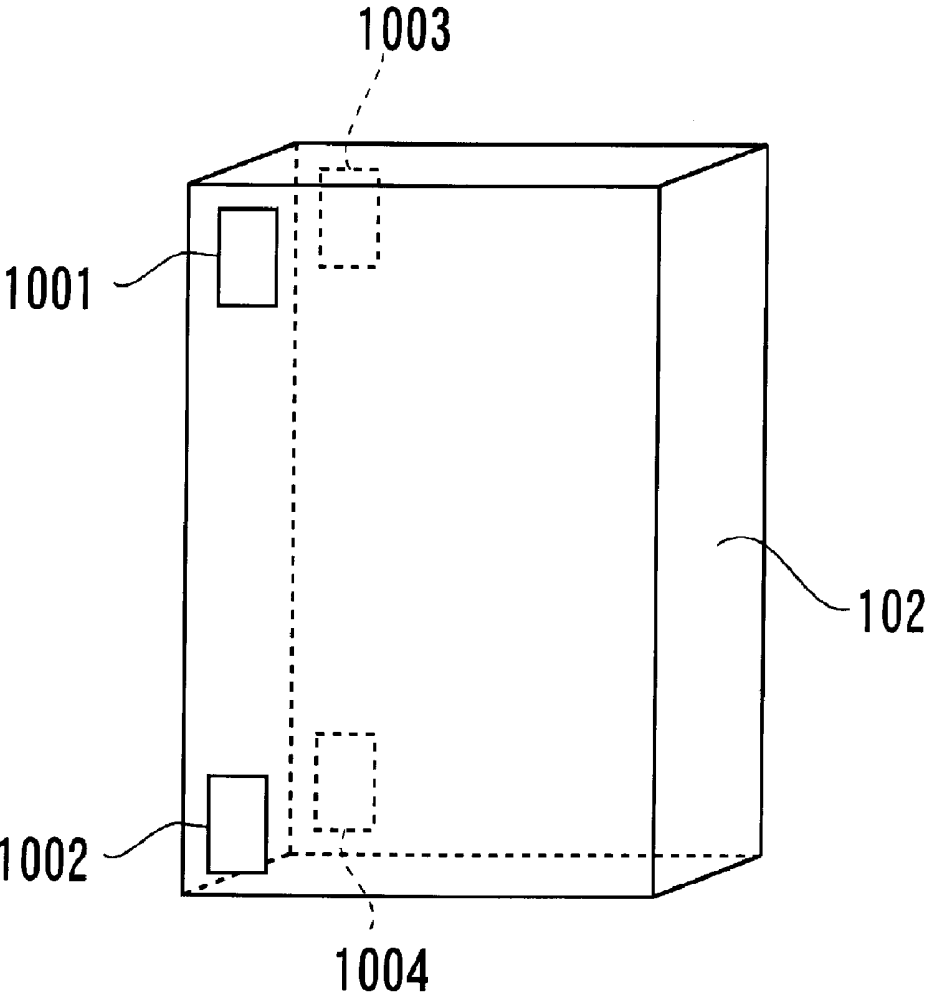

FIG. 10

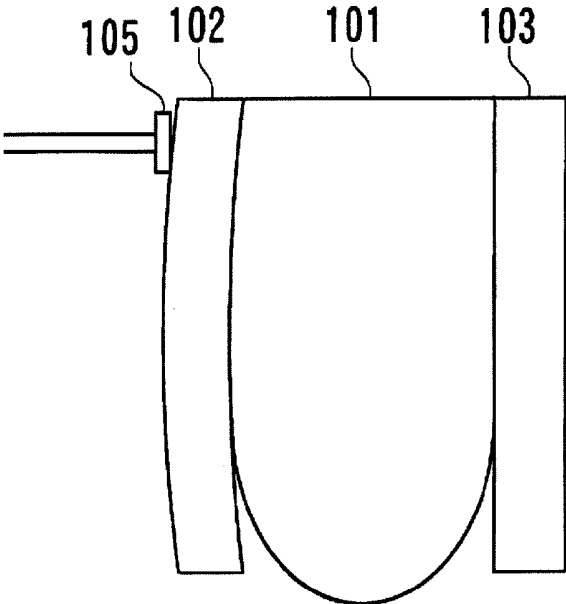

FIG. 11A

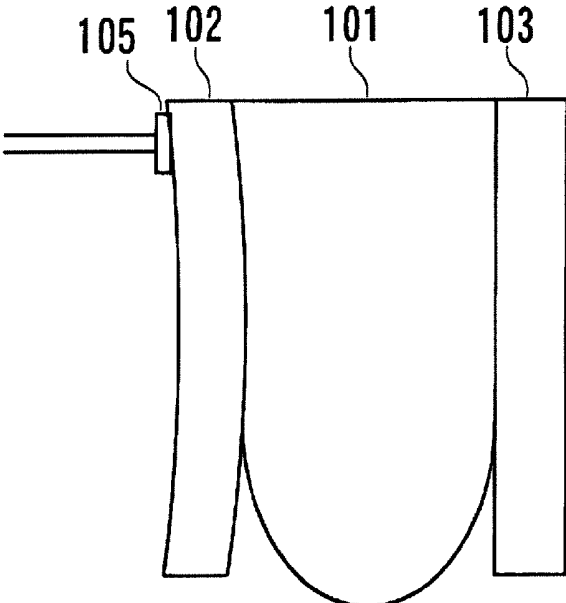

FIG. 11B

**ELASTIC WAVE RECEIVING APPARATUS,
ELASTIC WAVE RECEIVING METHOD,
PHOTOACOUSTIC APPARATUS, AND
PROGRAM**

RELATED APPLICATIONS

[0001] This application is a divisional of application Ser. No. 13/503,785, filed Apr. 24, 2012. It claims benefit of that application under 35 U.S.C. §120, and claims benefit under 35 U.S.C. §119 of Japanese Patent Application No. 2009-284541, filed on Dec. 15, 2009. The entire contents of each of the mentioned prior applications are incorporated herein by reference.

TECHNICAL FIELD

[0002] The present invention relates to an elastic wave receiving apparatus, an elastic wave receiving method, a photoacoustic apparatus and program.

BACKGROUND ART

[0003] In recent years, an apparatus for receiving an elastic wave generated from the inside of a subject by a probe and imaging the structure of the inside is being studied and developed. As one of applications, a photoacoustic diagnostic apparatus that irradiates the inside of a subject with a laser beam, receives a photoacoustic wave generated from the inside of the subject by an ultrasound probe, and displaying a tissue image of the inside of the subject is proposed (refer to, for example, NPL1). In an example of the photoacoustic diagnostic apparatus, a subject (breast) is compressed by plates and an ultrasound probe and irradiated with a pulse laser beam over the plate. A photoacoustic wave generated on the inside of the subject is received by the ultrasound probe, and a tissue image of the inside of the subject is reconstructed and displayed. A two-dimensional scanning mechanism capable of performing a two-dimensional scan by the probe and a pulse laser generator facing the probe to obtain a tissue image of the entire subject (breast) is provided, and a photoacoustic wave is measured in a plurality of measurement points.

[0004] An ultrasonic diagnosis apparatus having a mechanism of performing a mechanical scan by a probe and a method for controlling the same are known (refer to, for example, PTL1). In the ultrasonic diagnosis apparatus, the probe is provided with a position detector, a speed signal is generated from a position signal, and the difference between a target position and target speed is fed back to a drive signal of the probe.

[0005] In those diagnosis apparatuses, at the time of receiving a photoacoustic wave or ultrasound generated in the subject by the probe, when there is a space between the subject and the probe, the picture quality of a tissue image of the part deteriorates markedly for the following reason. The acoustic impedance of air in the space and that of the subject are largely different from each other, and the ultrasonic wave hardly passes through the space. To avoid the issue, a matching agent whose acoustic impedance is close to that of the subject is inserted between the probe and the subject so as not to have a space. To prevent a space from being created at the time of performing a mechanical scan by the probe, the probe, the subject, and the plates have to be sufficiently closely attached to each other so as not to have a space.

CITATION LIST

Patent Literature

[0006] PTL 1: Japanese Patent Application Laid-Open No. 2004-195088

Non Patent Literature

[0007] NPL 1: Srirang Manohar, et. al: Region-of-interest breast studies using the Twente Photoacoustic Mammoscope (PAM), Proc. of SPIE, Vol. 6437, pp. 1-9, 2007.

SUMMARY OF INVENTION

Technical Problem

[0008] However, in a conventional photoacoustic diagnosis apparatus, a subject is compressed by plates and a matching agent is applied measurement by measurement. At this time, there is a case that a load at the time of moving the probe over the plate fluctuates due to individual difference of the subject, strain of the plates, scratch, an application state of a matching agent, fluctuations in atmosphere temperature, and the like. Consequently, due to the load fluctuations, there is a case that the position of the probe upon reception of the photoacoustic wave is deviated from the target position, and the precision of the reconstructed tissue image deteriorates. In the case where the load on the probe at the time of movement over the plate becomes large and the position of the probe is markedly deviated, measurement has to be started again, and it requires extra laser beam application to the subject. There is an issue that the stress on the patient increases. Further, to drive the probe accurately to the target position in spite of a large load, an actuator of larger capacity is necessary, and an issue occurs such that cost reduction of the apparatus is hindered.

[0009] The present invention has been devised in consideration of the situations of the conventional arts as described above. An object of the present invention is to provide an elastic wave receiving apparatus and an elastic wave receiving method realizing increased position precision of a probe without increasing cost even in a situation that the load on the probe at the time of movement over a plate fluctuates.

Solution to Problem

[0010] An elastic wave receiving apparatus according to this invention comprising:

[0011] a plate-like member that supports a subject in a supporting side as one of faces;

[0012] a probe that receives an elastic wave generated from the subject by scanning a scanning side as the other side of the supporting side of the plate-like member;

[0013] a driving unit that drives the probe so as to scan the scanning side of the plate-like member;

[0014] a drive controlling unit that supplies a drive signal to the driving unit so that the probe moves to a predetermined target position on the scanning side; and

[0015] an information acquiring unit that preliminarily acquires and stores a physical value corresponding to a load generated in the driving unit when the scanning side is scanned by the probe,

[0016] wherein the drive controlling unit corrects the drive signal so that the probe moves to the target position regardless of the load by using the physical value stored in the information acquiring unit.

[0017] An elastic wave receiving method according to this invention for making a probe scan a plate-like member that supports a subject by an instruction signal to move the probe to a predetermined target position, and receiving an elastic wave generated from the subject by the probe, comprising:

[0018] an information acquiring step of preliminarily acquiring a physical value corresponding to a load necessary to move the probe, over the plate-like member;

[0019] an instruction signal correcting step of correcting the instruction signal by using the physical value acquired in the information acquiring step; and

[0020] a driving step of moving the probe to the target position by the instruction signal corrected in the instruction signal correcting step.

Advantageous Effects of Invention

[0021] According to the present invention, by estimating a load at the time of making a probe scan the surface of a plate-like member and changing a driving method so that the probe can move to a target position, the position precision of the probe can be increased and the precision of a tissue image can be improved without increasing cost.

[0022] Further features of the present invention will become apparent from the following description of exemplary embodiments with reference to the attached drawings.

BRIEF DESCRIPTION OF DRAWINGS

[0023] FIG. 1 is a block diagram of an elastic wave receiving apparatus according to a first embodiment of the invention.

[0024] FIG. 2 is a flowchart showing a measurement flow according to the first embodiment of the invention.

[0025] FIG. 3 is a diagram showing a mode of a scan of a probe according to the first embodiment of the invention.

[0026] FIG. 4 is a diagram showing the relation between a target position of the probe and time.

[0027] FIG. 5 is a diagram showing the relation between a measurement position of the probe and time.

[0028] FIG. 6 is a block diagram of an elastic wave receiving apparatus according to a second embodiment of the invention.

[0029] FIG. 7 is a flowchart showing a measurement flow according to the second embodiment of the invention.

[0030] FIG. 8 is a block diagram of an elastic wave receiving apparatus according to a third embodiment of the invention.

[0031] FIG. 9 is a flowchart showing a measurement flow according to the third embodiment of the invention.

[0032] FIG. 10 is a diagram showing layout of strain gauges in the third embodiment of the invention.

[0033] FIGS. 11A and 11B are diagrams showing example of a state of compression plates in the third embodiment of the invention.

DESCRIPTION OF EMBODIMENTS

[0034] Embodiments for carrying out the present invention will be illustratively and specifically described below with reference to the drawings.

Example 1

[0035] FIG. 1 is a block diagram showing a schematic configuration of an elastic wave receiving apparatus according to the embodiment. In FIG. 1, a configuration other than

a light source 104 corresponds to an elastic wave receiving apparatus, and a configuration including the light source 104 corresponds to a photoacoustic apparatus. In FIG. 1, 101 denotes a breast as a subject. The subject 101 is supported by being sandwiched and compressed by compression plates 102 and 103 each having a plate-like shape as a plate-like member. The compression plate 102 compresses and supports the subject by its supporting side as one of sides. In this state, a laser beam L for making the subject 101 generates a photoacoustic wave is emitted from the pulse laser light source 104. The pulse laser light source 104 irradiates the subject 101 with the laser beam L while making the laser beam L fluctuate in pulses at predetermined frequency. A photoacoustic wave generated when energy of the emitted laser beam is absorbed by the subject 101 and diffused is received as an elastic wave W by a probe 105 and converted to an electric signal. By being driven by a motor 106 as a driving unit, the probe 105 can two-dimensionally scan the surface of the scanning side as the opposite side of the supporting side of the compression plate 102 in the entire subject 101.

[0036] The motor 106 is a pulse motor, which is driven by a pulse signal S3 generated by a controller 107 as a drive controller, and the driving of the motor 106 is controlled according to the number and frequency of the pulse signals S3 output from the controller 107. Concretely, the rotational angle of the motor 106 changes in proportion to the number of pulse signals S3. The rotation speed of the motor 106 changes in proportion to the frequency of the pulse signal S3. That is, by controlling the number and frequency of the pulses output from the controller 107, the position, speed, and acceleration of the probe 105 can be controlled. The position information on the compression plate 102 of the probe 105 is acquired by an encoder 108 as a position detecting unit.

[0037] Position information S1 of the probe 105 acquired by the encoder 108 is transmitted to a load estimating unit 109 as an information acquiring unit. In the load estimating unit 109, an estimation value corresponding to a load at the time of making the probe 105 move over the compression plate 102 is calculated based on the position information S1 of the probe 105 and stored. The load estimating unit 109 includes a microcontroller (or computer) and software (or a program) assembled in the microcontroller. An estimation value S2 corresponding to the load calculated by the load estimating unit 109 is transmitted to the controller 107. The controller 107 has the function of changing the number and timing of the drive pulse signals of the motor 106 based on the transmitted estimation value S2. A user interface 110 is an interface used by the operator to perform an operation start instruction of the elastic wave receiving apparatus, an end instruction, reception data viewing, and the like.

[0038] FIG. 2 shows a measurement flow since the subject 101 is supported by being compressed by the compression plates 102 and 103 until an elastic wave is received/recorded by the probe 105 in the case where the elastic wave receiving apparatus according to the embodiment is used. When the measurement flow starts, first, in step S201, the subject 101 is compressed/supported by the compression plates 102 and 103, and completion of setup of the subject 101 is detected. Concretely, the operator performs a series of preparations such as compression of the subject 101, fixing, and application of the matching agent and, after that, transmits an operation start instruction signal to the controller 107 via the

user interface 110. By detecting the operation start instruction signal by the controller 107, completion of setup of the subject 101 is detected.

[0039] In step S202, the controller 107 generates a motor drive signal based on a predetermined target position at each time of the probe 105 to start a scan of the probe 105. The details of the scan of the probe 105 will now be described with reference to FIGS. 3 and 4. FIG. 3 is a diagram when the subject 101 and the compression plate 102 are seen from the direction of the probe 105. In FIG. 3, 302 indicates a scan region as a region to be scanned in the subject 101 by the probe 105. In FIG. 3, the left upper corner in the diagram of the scan region 302, a right-pointing axis in the horizontal direction is defined as X axis, and a down-pointing axis in the perpendicular direction is defined as Y axis. In the embodiment, the controller 107 makes the probe 105 scan the scan region 302 in a pattern indicated by an arrow 301. For simplicity, the case where the probe 105 performs a scan once in the X axis direction will be assumed and described.

[0040] FIG. 4 is a diagram showing a target position $f(t)$ at each predetermined time. In the diagram, time at which the operator gives the measurement start instruction is set as "0", and the horizontal axis indicates time "t". The vertical axis indicates the horizontal position X of the probe 105. The target position $f(t)$ of the probe 105 in each time is expressed by a solid line 405. In $f(t)$, at time of a point 401, the probe 105 starts moving at time indicated by the point 401 and accelerates at constant acceleration until time indicated by a point 402. After that, the probe 105 moves at constant speed until time indicated by a point 403 and decelerates at constant acceleration until time indicated by a point 404. At the time indicated by the point 404, the probe 105 reaches the right end of the scan region.

[0041] Description of the measurement flow of FIG. 2 will be continued. The target position $f(t)$ of the probe 105 at each time is calculated in advance at predetermined time intervals "dt" and stored in an internal memory of the controller 107. The number $N(t)$ of pulses, which are input from the controller 107 to the motor 106 from time "t" to time "t+dt" in step S202, is calculated by the following expression (1).

[Math. 1]

$$N(t) = \frac{f(t+dt) - f(t)}{p} \quad (1)$$

[0042] where the amount of movement of the probe 105 performed in response to input of the pulse signal once to the motor 106 is expressed as "p".

[0043] In actual elastic wave measurement, the scan is repeated along the pattern 301, and the entire scan region 302 is scanned with the probe 105. When the scan of the probe 105 starts, in step S203, the position data of the probe 105 is acquired at predetermined time intervals by using the encoder 108. The position data and data indicative of the time is input to the load estimating unit 109.

[0044] During a scan of the probe 105, the process in step S203 is continued. After completion of the scan of the probe 105 in step S204, in subsequent step S205, a load (necessary for movement) at the time of moving the probe 105 over the compression plate 102 is estimated by the load estimating unit 109. The load estimating unit will be described in detail

by using FIG. 5. In FIG. 5, the solid line 405 indicates the target position $f(t)$ of the probe 105. A broken line 501 indicates the actual position of the probe 105 measured in step S203. In a place where the value of X of the broken line 501 is larger than the value of X at the same time indicated by the solid line 405, it is determined that the load at the time of moving the probe 105 over the compression plate 102 is smaller than an assumed value. On the other hand, in a place where the value of X of the broken line 501 is smaller than the value of X at the same time indicated by the solid line 405, it is determined that the load at the time of making the probe 105 scan the surface of the compression plate 102 is larger than an assumed value.

[0045] It is understood that, for example, around the point 502 shown in FIG. 5, the tilt of the actual position 501 of the probe 105 decreases and is deviated from the target position 405. It shows that the load at the time of moving the probe 105 over the compression plate 102 increases around the point 502 and the probe 105 cannot be accurately moved to a target position at each time by the position control of the probe 15 executed in step S202. To address the situation, in the embodiment, a load correction function $C(t)$ is calculated and, by using the load correction function $C(t)$, the position of the probe 105 is corrected. The actual measurement position of the probe 105 at time "t" shown by the broken line 501 is expressed as $g(t)$, "k" is set as a predetermined positive constant, and the load correction function $C(t)$ is defined as the following expression (2).

[Math. 2]

$$C(t) = k\{f(t) - g(t)\} \quad (2)$$

[0046] For example, around the point 502, the load correction function $C(t)$ is a positive value.

[0047] After completion of the process in step S205, subsequently in step S206, the load estimating unit 109 changes the driving method (control parameter) on the motor 106 based on the load correction function $C(t)$ and sets it in the controller 107. In the embodiment, it is assumed that a value obtained by adding the load correction function $C(t)$ to the input number $N(t)$ of pulses every time interval dt which is preliminarily set is set as a corrected pulse input number $N'(t)$. The controller 107 re-calculates the corrected pulse input number $N'(t)$ at time interval dt to update the data in the memory in the controller 107.

[0048] After completion of the process in step S206, subsequently in step S207, control of making a pulse laser beam emitted from the light source 104 repeatedly in predetermined cycles starts. In step S208 subsequent to the process in step S207, the controller 107 starts the driving of the motor 106 (and the probe 105) by using the corrected pulse input number $N'(t)$. Simultaneously, the light source 104 is driven so as to be opposed to the probe 105, and a photoacoustic wave generated in the subject 101 by the pulse laser beam is received by the probe 105.

[0049] For example, around the point 502, the controller 107 makes pulse signals generated more than the first pulse input number $N(t)$ based on the corrected pulse input number $N'(t)$ so that the probe 105 can follow the target position $f(t)$. Consequently, also in the case where the load at the time of movement of the probe 105 increases around the point 502, the actual position of the probe 105 at each time can be made closer to the first target position $f(t)$. When the scan of the probe 105 starts in step S208, in step S209, control of receiving a photoacoustic wave generated from the inside of

the subject **101** by the probe **105** and converting it to an electric signal is executed. The electric signal is subjected to signal processing and imaging by another routine (not shown), and an image may be displayed in the user interface **110**. Until the probe **105** reaches the right end X_{max} of the scan region, the movement of the probe and the reception of the photoacoustic wave are performed repeatedly. When the probe **105** reaches the right end X_{max} of the scan region, the scan of the probe is finished in step **S210** and reception and recording of the elastic wave is also finished.

[0050] In the measurement flow, the processes in step **S202** to **S204** correspond to an information acquiring step. The processes in steps **S205** and **S206** correspond to an instruction signal correcting step. Further, the processes in steps **S208** to **S210** correspond to a driving step. The pulse input number $N(t)$ corresponds to an instruction signal. For example, in the case where coefficient of friction in a part of the compression plate **102** is low and the load is small, the controller **107** generates pulse signals of the number smaller than the initial pulse input number $N(t)$ based on the corrected pulse input number $N'(t)$. In such a manner, the probe **105** can follow the target position $f(t)$. Therefore, also in the case where the load at the movement of the probe **105** is small, the actual position of the probe **105** at each time can be made closer to the initial target position $f(t)$.

[0051] In the above example, the case where a scan is performed once in the X direction in FIG. 3 by the probe **105** has been described. However, in reality, the value of the target position $f(t)$ also on each Y coordinate is stored and the corrected pulse input number $N'(t)$ is calculated at each Y coordinate by a similar method. In such a manner, variations in each place of the load at the time of moving the probe **105** over the compression plate **102** can be corrected in the entire scan region **302**. Although the expression in which the difference between the measurement position and the target position is multiplied by a positive constant is used as the load correction function $C(t)$ in the above example, the load correction function $C(t)$ is not always limited to the expression. Another function which changes according to the difference between the measurement position and the target position may be used. In the embodiment, the difference between the measurement position and the target position corresponds to a physical value corresponding to the load generated in the driving unit.

[0052] In the embodiment, as a corrected pulse input number, an expression of adding a pulse input number before correction and the load correction function $C(t)$ is used. However, the invention is not always limited to the expression. Another function which changes according to the value of the load correction function $C(t)$ may be used. In the embodiment, the method in which the acceleration start time is the same regardless of the load correction function $C(t)$ has been described. However, the acceleration start time may be also changed. For example, in the case where the load is estimated large, a driving method is changed so as to increase the pulse input number and hasten the timing of the pulse input (increase the drive speed and hasten the drive timing (or increase movement speed and hasten moving timing)). In such a manner, the probe can be moved to a target position before generation of a photoacoustic wave. On the other hand, for example, in the case where the load is estimated small, a driving method is changed so as to decrease the pulse input number and delay the timing of the pulse input (decrease the drive speed and

delay the drive timing (or decrease the movement speed and delay the moving timing)). In such a manner, the probe can be moved to a target position.

[0053] Although the embodiment has been described by using the example that the motor **106** is a pulse motor, the invention is not limited to the kind of the motor. A motor of another kind such as a servo motor may be used as long as the position and speed can be controlled from the controller **107**.

Example 2

[0054] FIG. 6 is a block configuration diagram showing a second embodiment of an elastic wave receiving apparatus according to the present invention. In the elastic wave receiving apparatus of the embodiment, to correct variations in the load in association with movement of the probe **105** due to temperature fluctuations, a temperature sensor **601** and a load estimating unit **602** are provided. In FIG. 6, the subject **101**, the compression plate **102**, the compression plate **103**, the light source **104**, the probe **105**, the motor **106**, the controller **107**, and the user interface **110** are similar to those in the first embodiment, so that their description will not be repeated. FIG. 7 shows a measurement flow using the elastic wave receiving apparatus since the subject **101** in the second embodiment of the invention is sandwiched, compressed, and supported by the compression plates **102** and **103** until an elastic wave is received by the probe **105**.

[0055] In step **S701**, the operator performs a series of preparations such as compression of the subject **101**, fixing, and application of the matching agent and, after that, transmits an operation start instruction signal to the controller **107**. When the operation start instruction signal is detected by the controller **107**, completion of setup of the subject **101** is detected. In step **S702**, the temperature of the compression plate **102** is measured by the temperature sensor **601** as a temperature detecting unit. A thermistor element is adhered onto the compression plate **102**, and the temperature of the compression plate **102** is measured from a resistance value of the thermistor element. Subsequently, in step **S703**, the load estimating unit **602** estimates the load related to movement of the probe **105** based on the target position $f(t)$ indicated by the solid line **405** in FIG. 4 and temperature T measured in step **S702**.

[0056] When viscosity at the temperature T of the matching agent is set as $u(T)$, a load $D(t)$ by viscous property of the matching agent when the probe **105** moves over the compression plate **102** is proportional to viscosity and speed. The speed is obtained by time-differentiating $f(t)$. That is, the load $D(t)$ is estimated by the following expression (3) using $u(T)$ and $f(t)$.

[Math. 3]

$$D(t) = u(T) \frac{f(t + dt) - f(t)}{dt} \quad (3)$$

[0057] The load correction function $C(t)$ is calculated by the following expression (4). "k" denotes a constant which is pre-stored internally.

[Math. 4]

$$C(t) = kD(t) \quad (4)$$

[0058] Generally, the lower the temperature T is, the larger the load $D(t)$ by the viscous property of the matching agent becomes. When the load $D(t)$ by the viscous property of the matching agent is large, the load correction function $C(t)$ also becomes a large value.

[0059] In step S704, the load estimating unit 109 changes the target position based on the load correction function $C(t)$ and sets it in the controller 107. In the embodiment, a value obtained by adding the load correction function $C(t)$ to the predetermined pulse input number $N(t)$ is set as a corrected pulse input number $N'(t)$. The controller 107 re-calculates the corrected pulse input number $N'(t)$ at time intervals dt and updates the internal memory. Subsequently, in step S705, control of repeatedly emitting a pulse laser from the light source 104 in predetermined cycles is started. In the following step S706, the controller 107 starts driving the motor 106 and the probe 105 by using the corrected pulse input number $N'(t)$. Concurrently, the light source 104 is also driven so as to face the probe 105 so that a photoacoustic wave generated on the inside of the subject 101 by the pulse laser beam can be received by the probe 105.

[0060] For example, in the case where it is expected that the temperature of the compression plate 102 is low and the load related to movement of the probe 105 is large, the controller 107 generates pulse signals more than the initial pulse input number $N(t)$ based on the corrected pulse input number $N'(t)$ so that the probe 105 can follow the target position $f(t)$. Consequently, also in the case where the load related to movement of the probe 105 increases due to low temperature, the position and time of the probe 105 can be made closer to the target position $f(t)$. For example, in the case where it is expected that the temperature of the compression plate 102 is high and the load related to movement of the probe 105 is small, the controller 107 generates pulse signals smaller than the first pulse input number $N(t)$ based on the corrected pulse input number $N'(t)$ so that the probe 105 can follow the target position $f(t)$. Consequently, also in the case where the load related to movement of the probe 105 decreases due to high temperature, the position and time of the probe 105 can be made closer to the target position $f(t)$.

[0061] Subsequently, in step S707, control of receiving a photoacoustic wave generated from the inside of the subject 101 by the probe 105 and converting it to an electric signal is executed. The electric signal may be subjected to signal processing and imaging on the outside and an image may be displayed in the user interface 110. In step S708, the scan with the probe 105 and reception of the elastic wave is finished. In the measurement flow, the process in step S702 corresponds to an information acquiring step. The processes in steps S703 and S704 correspond to an instruction signal correcting step. Further, the processes in steps S706 to S708 correspond to a driving step. The pulse input number $N(t)$ corresponds to an instruction signal.

[0062] As described above, according to the second embodiment of the invention, fluctuations in the load related to movement of the probe 105 accompanying temperature fluctuations can be estimated by a simple method without making the probe 105 scan before measurement. Consequently, without increasing the measurement time, the load fluctuations accompanying temperature fluctuations are corrected, and the position precision of the probe 105 can be improved. Although the expression in which a product of viscosity and speed is multiplied by a positive constant is

used as the load correction function $C(t)$ in the above example, the load correction function $C(t)$ is not always limited to the expression. Another function which changes according to temperature may be used. Although the expression in which the pulse input number $N(t)$ before correction and the load correction function $C(t)$ are added is used as the corrected pulse input number $N'(t)$ in the embodiment, the invention is not always limited to the expression. Another function which changes according to the value of the load correction function $C(t)$ may be used. In the embodiment, the temperature of the compression plate 102 corresponds to the physical value corresponding to the load generated in the driving unit.

[0063] In the embodiment, the method in which the acceleration start time of the probe 105 is the same regardless of the load correction function $C(t)$ has been described. However, the acceleration start time may be also changed together with a change in the number of input pulses. For example, in the case where the load related to movement of the probe 105 is estimated large, a driving method is changed so as to increase the pulse input number and hasten the timing of the pulse input (increase the drive speed and hasten the drive timing (or increase the movement speed and hasten the moving timing)). In such a manner, the probe 105 can be moved to a target position well in advance of generation of a photoacoustic wave. On the other hand, for example, in the case where the load related to movement of the probe 105 is estimated small, a driving method is changed so as to increase the pulse input number and delay the timing of the pulse input (decrease the drive speed and delay the drive timing (or decrease the movement speed and delay the moving timing)). In such a manner, the probe 105 can be moved to a target position.

Example 3

[0064] FIG. 8 is a block configuration diagram showing a third embodiment of an elastic wave receiving apparatus according to the present invention. In the elastic wave receiving apparatus of the embodiment, to correct variations in a friction load caused by a strain in the compression plate 102 which occurs when the subject 101 is fixed to the compression plate 102, a strain sensor 801 as a strain detecting unit and a load estimating unit 802 as an information acquiring unit are provided. In FIG. 8, the subject 101, the compression plate 102, the compression plate 103, the light source 104, the probe 105, the motor 106, the controller 107, and the user interface 110 are similar to those in the first embodiment, so that their description will not be repeated.

[0065] FIG. 9 shows a measurement flow using the elastic wave receiving apparatus since the subject 101 in the third embodiment of the invention is fixed by the compression plates 102 and 103 until an elastic wave is received by the probe 105. In step S901, in a manner similar to the first and second embodiments, completion of setup of the subject 101 is detected. Next, in step S902, a strain in the compression plate 102 is measured by the strain sensor 801. The details of layout of the strain sensors 801 are shown in FIG. 10. Strain gauges 1001 and 1002 are adhered at both ends of a face on the probe 105 side, of the compression plate 102. Strain gauges 1003 and 1004 are adhered to both ends of a face on the subject 101 side. In step S902, the resistance value of each of the strain gauges is detected. In FIG. 10, this

side of the drawing sheet is the face on the probe **105** side, and the depth side is the face on the subject **101** side.

[0066] Subsequently, in step S903, the load estimating unit **802** estimates friction load at each position based on the resistance value of each of the strain gauges measured in step S902. The basic concept is as follows. Specifically, when the resistance values of the strain gauges **1001** and **1002** increase and the resistance values of the strain gauges **1003** and **1004** decrease, it is considered that the compression plate **102** is distorted so as to project to the probe side as shown in FIG. 11A. In this case, the frictional force between the probe **105** and the compression plate **102** is large around the center part of the compression plate **102** and is small around ends. On the other hand, when the resistance values of the strain gauges **1001** and **1002** decrease and the resistance values of the strain gauges **1003** and **1004** increase, it is considered that the compression plate **102** is distorted so that the probe **105** side is recessed as shown in FIG. 11B. In this case, the frictional force between the probe **105** and the compression plate **102** is small in a center part and becomes large around ends.

[0067] Next, a concrete method for estimating the friction load will be described. In the embodiment, as the load correction function $C(t)$, the following quadratic function (5) is employed.

[Math. 5]

$$C(t) = A \left\{ \left(f(t) - \frac{h}{2} \right)^2 \right\} + B \quad (5)$$

[0068] When $A < 0$, B is defined as expression (6).

[Math. 6]

$$B = -A \frac{h^2}{4} \quad (6)$$

[0069] When $A \geq 0$, $B = 0$ is defined. “ h ” denotes length (height) from the lower end to the upper end of the compression plate **102** in FIGS. 11A and 11B.

[0070] A is defined by expression (7) and is a coefficient which becomes negative when the compression plate **102** is distorted so as to project to the probe side and becomes positive when the compression plate **102** is distorted so as to recess to the probe side. k denotes a positive constant which is determined at the time of shipping of the apparatus. The value of A is determined according to resistance values $R1001$, $R1002$, $R1003$, and $R1004$ of the strain gauges **1001**, **1002**, **1003**, and **1004**, respectively, detected in step S902 and is stored.

$$A = k \{ (R1003 \cdot R1004) / (R1002 \cdot R1001) - 1 \} \quad (7)$$

[0071] For example, in the case where the compression plate **102** is distorted so as to project to the probe side as shown in FIG. 11A, $(R1002 \cdot R1001) > (R1003 \cdot R1004)$ is satisfied and, as a result, “ A ” becomes a negative value. In this case, $C(t) = 0$ at ends ($f(t) = 0$ and $f(t) = h$) of the compression plate **102**, and the friction load is estimated small. $C(t) = -A(h^2/4)$ in the center ($f(t) = h/2$) of the compression plate **102**, and the friction load is estimated large. For example, in the case where the compression plate **102** is distorted so as to

recess as shown in FIG. 11B, $(R1002 \cdot R1001) < (R1003 \cdot R1004)$ is satisfied and A becomes a positive value. In this case, $C(t) = A(h^2/4)$ at ends ($f(t) = 0$ and $f(t) = h$) of the compression plate **102**, and the friction load is estimated large. $C(t) = 0$ in the center ($f(t) = h/2$) of the compression plate **102**, and the friction load is estimated small. In the case where the compression plate **102** is not distorted, $(R1002 \cdot R1001) = (R1003 \cdot R1004)$ and, as a result, $A = B = 0$. In this case, $C(t)$ is always equal to zero ($C(t) = 0$).

[0072] Next, in step S904, the load estimating unit **802** changes the target position based on the load correction function $C(t)$ and sets it in the controller **107**. In the embodiment, a value obtained by adding the load correction function $C(t)$ to the predetermined pulse input number $N(t)$ is set as a corrected pulse input number $N'(t)$. The controller **107** re-calculates the corrected pulse input number $N'(t)$ at predetermined time intervals and updates the internal memory. Subsequently, in step S905, control of repeatedly emitting a pulse laser from the light source **104** in predetermined cycles is started. In step S906, the controller **107** starts driving the motor **106** and the probe **105** by using the corrected pulse input number $N'(t)$. Concurrently, the light source **104** is also driven so as to face the probe **105** so that a photoacoustic wave generated on the inside of the subject **101** by the pulse laser beam can be received by the probe **105**.

[0073] The operation of the probe **105** in the case where the compression plate **102** is distorted so as to project to the probe **105** side and the friction load is expected to be large around the center will now be considered. In this case, the controller **107** generates pulse signals more than the initial pulse input number $N(t)$ around the center of the compression plate **102** based on the corrected pulse input number $N'(t)$ so that the probe **105** can follow the target position $f(t)$. On the other hand, in the case where it is expected that the compression plate **102** is distorted so as to recess and the friction load is large around the ends, the controller **107** generates pulse signals more than the initial pulse input number $N(t)$ around the ends of the compression plate **102** based on the corrected pulse input number $N'(t)$ so that the probe **105** can follow the target position $f(t)$. Consequently, also in the case where the friction load changes in some place due to distortion of the compression plate **102**, the position at each time, of the probe **105** can be made closer to the target position $f(t)$.

[0074] Subsequently, in step S907, control of receiving a photoacoustic wave generated from the inside of the subject **101** by using the probe **105** and converting it to an electric signal is executed. The electric signal may be subjected to signal processing and imaging by another routine and an image may be displayed via the user interface **110**. In step S908, the scan and measurement of an elastic wave of the probe **105** is finished. According to the third embodiment of the invention, fluctuations in the friction load accompanying distortion of the compression plate **102** can be corrected by a simple method without making the probe **105** scan before measurement. Consequently, without increasing the measurement time, the load fluctuations accompanying distortion of the compression plate **102** are corrected, and the position precision of the probe **105** can be improved. In the measurement flow, the process in step S902 corresponds to the information acquiring step. The processes in steps S903 and S904 correspond to the instruction signal correcting

step. Further, the processes in steps S906 to S908 correspond to the driving step. The pulse input number $N(t)$ corresponds to an instruction signal.

[0075] Although the quadratic function expressed by the expression (5) is used as the load correction function $C(t)$ in the above example, the load correction function $C(t)$ is not always limited to the expression. Another function which changes according to a measurement value of a strain gauge may be used. Although the expression in which the pulse input number $N(t)$ before correction and the load correction function $C(t)$ are added is used as the corrected pulse input number $N'(t)$ in the embodiment, the invention is not always limited to the expression. Another function which changes according to the value of the load correction function $C(t)$ may be used. In the embodiment, the method in which the acceleration start time is the same regardless of the load correction function $C(t)$ has been described. However, the acceleration start time may be also changed together with a change in the number of input pulses. For example, in the case where the load is estimated large, a driving method is changed so as to increase the pulse input number and hasten the timing (increase the drive speed and hasten the drive timing (or increase the movement speed and hasten the moving timing)). In such a manner, the probe 105 can be moved to a target position well in advance of generation of a photoacoustic wave. On the other hand, for example, in the case where the load is estimated small, a driving method is changed so as to decrease the pulse input number and delay the timing (decrease the drive speed and delay the drive timing (or decrease the movement speed and delay the moving timing)). In such a manner, the probe 105 can be moved to a target position. In the embodiment, the distortion of the compression plate 102 corresponds to a physical value corresponding to the load generated in the driving unit.

[0076] While the present invention has been described with reference to exemplary embodiments, it is to be understood that the invention is not limited to the disclosed exemplary embodiments. The scope of the following claims is to be accorded the broadest interpretation so as to encompass all such modifications and equivalent structures and functions.

1. A photoacoustic wave receiving apparatus comprising:
 - a supporting member configured to support a subject;
 - a scanning light source located opposing the subject via the supporting member and configured to irradiate the subject with pulsed light;
 - a scanning probe acoustically and slidably in contact with the supporting member and configured to receive a photoacoustic wave propagated from the subject via the supporting member and output an electric signal;
 - a driving unit configured to move said scanning probe and said scanning light source along the supporting member;
 - a drive controlling unit that supplies a drive signal to said driving unit configured to control a movement of said scanning probe; and
 - a load estimation unit configured to estimate a scanning load generated due to an acoustic contact between the scanning probe and the supporting member,
 wherein said drive controlling unit corrects the drive signal based on an estimated scanning load in a feed-forward manner so as to reduce scanning inaccuracy due to fluctuation of the scanning load.

2. The photoacoustic wave receiving apparatus according to claim 1, wherein said load estimation unit has a strain detecting unit that detects a strain in said supporting member, and the strain detected is stored as the estimated scanning load in said load estimation unit.

3. The photoacoustic wave receiving apparatus according to claim 1, wherein the scanning probe is slidably contacted with the supporting member via an acoustic impedance matching agent.

4. The photoacoustic wave receiving apparatus according to claim 1, wherein the estimated scanning load is acquired by at least any one of measurement and calculation.

5. The photoacoustic wave receiving apparatus according to claim 1, wherein said load estimation unit estimates the estimated scanning load before the photoacoustic wave is received by the scanning probe.

6. The photoacoustic wave receiving apparatus according to claim 1, wherein said drive controlling unit corrects the drive signal before the photoacoustic wave is received by the scanning probe.

7. The photoacoustic wave receiving apparatus according to claim 1, wherein, at the time of acquiring the estimated scanning load, said scanning of the scanning probe is performed in a state in which no photoacoustic wave is generated from the subject.

8. The photoacoustic wave receiving apparatus according to claim 1, wherein said load estimation unit has a position detecting unit that detects a position of said scanning probe, said scanning of the scanning probe is performed in advance, and the difference between a position of said scanning probe detected and the predetermined target position is stored in said load estimation unit as the estimated scanning load.

9. The photoacoustic wave receiving apparatus according to claim 8, wherein, when the estimated scanning load is larger than a reference scanning load which is assumed from the predetermined target position, said drive controlling unit increases driving speed or hastens drive timing of said scanning probe.

10. The photoacoustic wave receiving apparatus according to claim 8, wherein, when the estimated scanning load is smaller than a reference scanning load which is assumed from the predetermined target position, said drive controlling unit decreases driving speed or delays drive timing of said scanning probe.

11. The photoacoustic wave receiving apparatus according to claim 1, wherein said load estimation unit has a temperature detecting unit that detects a temperature of said supporting member, and the detected temperature is stored in said load estimation unit as to the estimated scanning load.

12. The photoacoustic wave receiving apparatus according to claim 11, wherein said load estimation unit stores information regarding viscosity of a matching agent applied to the supporting member as to the estimated scanning load.

13. A photoacoustic wave receiving method for photoacoustic wave receiving apparatus including a supporting member, a scanning light source and a scanning probe, comprising:
 - supporting a subject with the supporting member;
 - estimating a scanning load occurring between the scanning probe and the supporting member;
 - correcting a scanning instruction signal based on an estimated scanning load;

irradiating the subject with a pulsed light by using the scanning light source;
receiving a photoacoustic wave generated in the subject by using the scanning probe; and
moving the scanning probe and the scanning light source, wherein the irradiating the subject with the pulsed light and the receiving the photoacoustic wave are performed simultaneously during the moving the scanning probe based on the corrected instruction signal.

14. The photoacoustic wave receiving method according to claim **13**, wherein, in said load estimation step, the estimated scanning load is estimated based on a result acquired by making the scanning probe scan over the supporting member in a state where no photoacoustic wave is generated from the subject.

15. The photoacoustic wave receiving method according to claim **13**, wherein, in said load estimation step, position information of the scanning probe is acquired as the estimated scanning load by making the scanning probe scan over the supporting member, and the difference between acquired position information and the target position of the scanning probe is calculated, and

in said instruction signal correcting step, movement speed or movement timing of the scanning probe is changed so as to decrease the difference between the position of the scanning probe and the target position.

16. The photoacoustic wave receiving method according to claim **13**, wherein, in said load estimation step, a temperature of the supporting member is acquired as the estimated scanning load.

17. The photoacoustic wave receiving method according to claim **13**, wherein, in said load estimation step, a strain of the supporting member is acquired as the estimated scanning load.

18. The photoacoustic wave receiving method according to claim **13**, wherein, in said instruction signal correcting step, in a case in which the estimated scanning load acquired in the load estimation step is larger than a reference scanning load which is assumed from the target position, the instruction signal is corrected so that drive speed or drive timing of the scanning probe is increased or hastened.

19. The photoacoustic wave receiving method according to claim **13**, wherein, in said instruction signal correcting step, when the estimated scanning load acquired in the load estimation step is smaller than a reference scanning load which is assumed from the target position, the instruction signal is corrected so that drive speed or drive timing of the scanning probe is decreased or delayed.

20. A non-transitory computer-readable medium, storing, in executable form, a program for making a computer execute an load estimation step, an instruction signal correcting step, and a drive step in the photoacoustic wave receiving method according to claim **13**.

21. The photoacoustic wave receiving method according to claim **13**, wherein the estimating is performed before the scanning.

22. The photoacoustic wave receiving method according to claim **13**, wherein the estimating is performed before the irradiating the subject with the pulsed light and the receiving the photoacoustic wave.

23. The photoacoustic wave receiving method according to claim **13**, wherein the estimating is performed before the irradiating the subject with the pulsed light and the receiving the photoacoustic wave.

* * * * *

专利名称(译)	弹性波接收装置，弹性波接收方法，光声装置和程序		
公开(公告)号	US20180024047A1	公开(公告)日	2018-01-25
申请号	US15/720752	申请日	2017-09-29
[标]申请(专利权)人(译)	佳能株式会社		
申请(专利权)人(译)	佳能株式会社		
当前申请(专利权)人(译)	佳能株式会社		
[标]发明人	SUZUKI KOICHI		
发明人	SUZUKI, KOICHI		
IPC分类号	G01N21/17 A61B5/00		
CPC分类号	G01N2021/1706 G01N21/1702 A61B5/0091 A61B5/4312 A61B5/0095 A61B5/6843		
优先权	PCT/JP2010/072600 2010-12-09 WO 2009284541 2009-12-15 JP 13/503785 2012-04-24 US		
其他公开文献	US10324027		
外部链接	Espacenet USPTO		

摘要(译)

一种弹性波接收装置，包括：探测器，接收从对象产生的弹性波；板状压板，支撑物体，其表面由探头扫描；用于驱动探头的电动机；控制器，向电动机提供驱动信号，使探针移动到压缩板上的预定目标位置；负荷估计单元，其预先获取并存储与通过探头扫描压缩板时产生的负荷相对应的物理值。控制器通过使用存储在负荷估计单元中的物理值来校正驱动信号，使得探针移动到目标位置，而不管负载如何。

