



US 20170252027A1

(19) **United States**

(12) **Patent Application Publication**  
**Kasic, II**

(10) **Pub. No.: US 2017/0252027 A1**  
(43) **Pub. Date: Sep. 7, 2017**

(54) **SYSTEMS, DEVICES, COMPONENTS AND METHODS FOR DISPLACING AND REPOSITIONING THE ESOPHAGUS AWAY FROM THE HEART DURING ATRIAL ABLATION SURGICAL PROCEDURES**

(52) **U.S. Cl.**  
CPC .... *A61B 17/00234* (2013.01); *A61B 17/0218* (2013.01); *A61B 18/14* (2013.01); *A61B 5/0071* (2013.01); *A61B 18/1492* (2013.01); *A61B 2017/00323* (2013.01); *A61B 2018/00351* (2013.01)

(71) Applicant: **DNP Biomed, LLC**, Boulder, CO (US)

(72) Inventor: **James F. Kasic, II**, Boulder, CO (US)

(73) Assignee: **DNP Biomed, LLC**, Boulder, CO (US)

(21) Appl. No.: **15/603,176**

(22) Filed: **May 23, 2017**

**Related U.S. Application Data**

(63) Continuation-in-part of application No. 14/887,313, filed on Oct. 19, 2015, now Pat. No. 9,668,720.

**Publication Classification**

(51) **Int. Cl.**  
*A61B 17/00* (2006.01)  
*A61B 18/14* (2006.01)  
*A61B 5/00* (2006.01)  
*A61B 17/02* (2006.01)

(57) **ABSTRACT**

Disclosed are various embodiments of systems, devices, components and methods for re-positioning or displacing a patient's esophagus a safe distance away from the patient's heart during an atrial ablation surgical procedure. An esophageal displacement catheter is disclosed that is configured to reposition a patient's esophagus 20 mm or more away from the ablation location in the patient's heart. A distendable section of the catheter is configured such that portions of a first pulling member extend sufficiently far away from joints located in the distendable section when the first pulling member is in a retracted position to permit the distendable section to assume a deployed and distended configuration. At least one flexible deformable or distendable member, sheath or covering is configured to be disposed over and cover the portions of the first pulling member extending away from the joints when the distendable section is the deployed and distended configuration. One or more balloons can also be incorporated into the catheter to enlarge controllably the diameter of the distendable section.

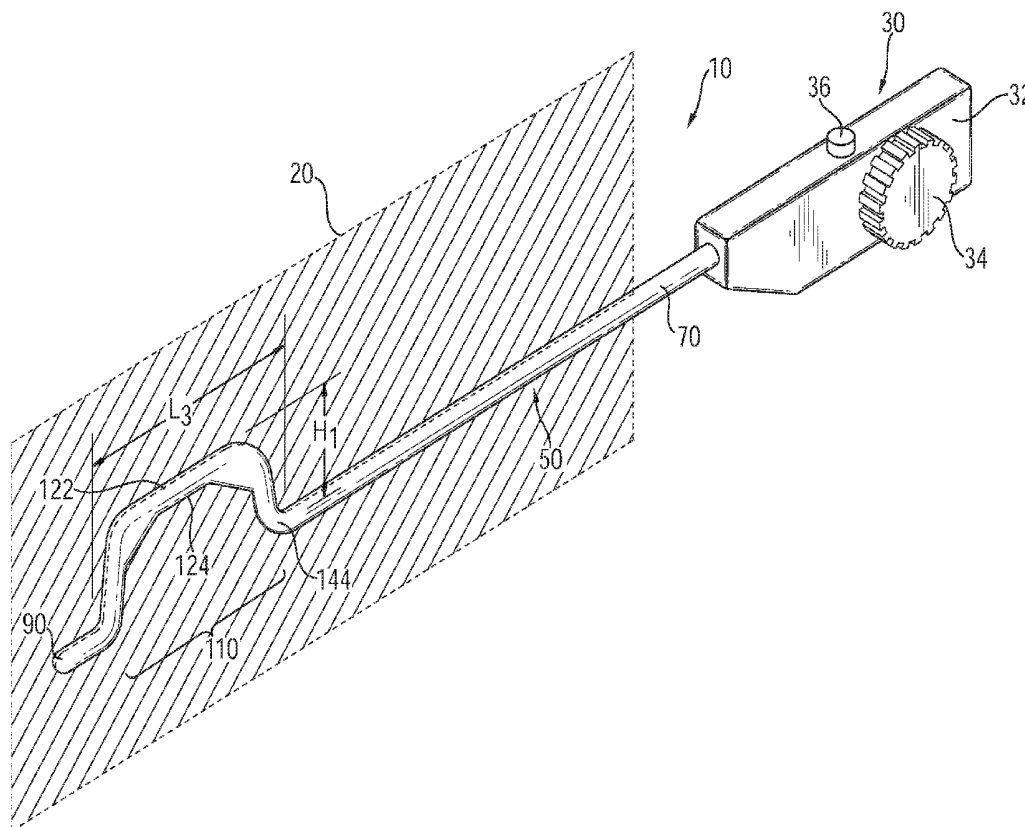

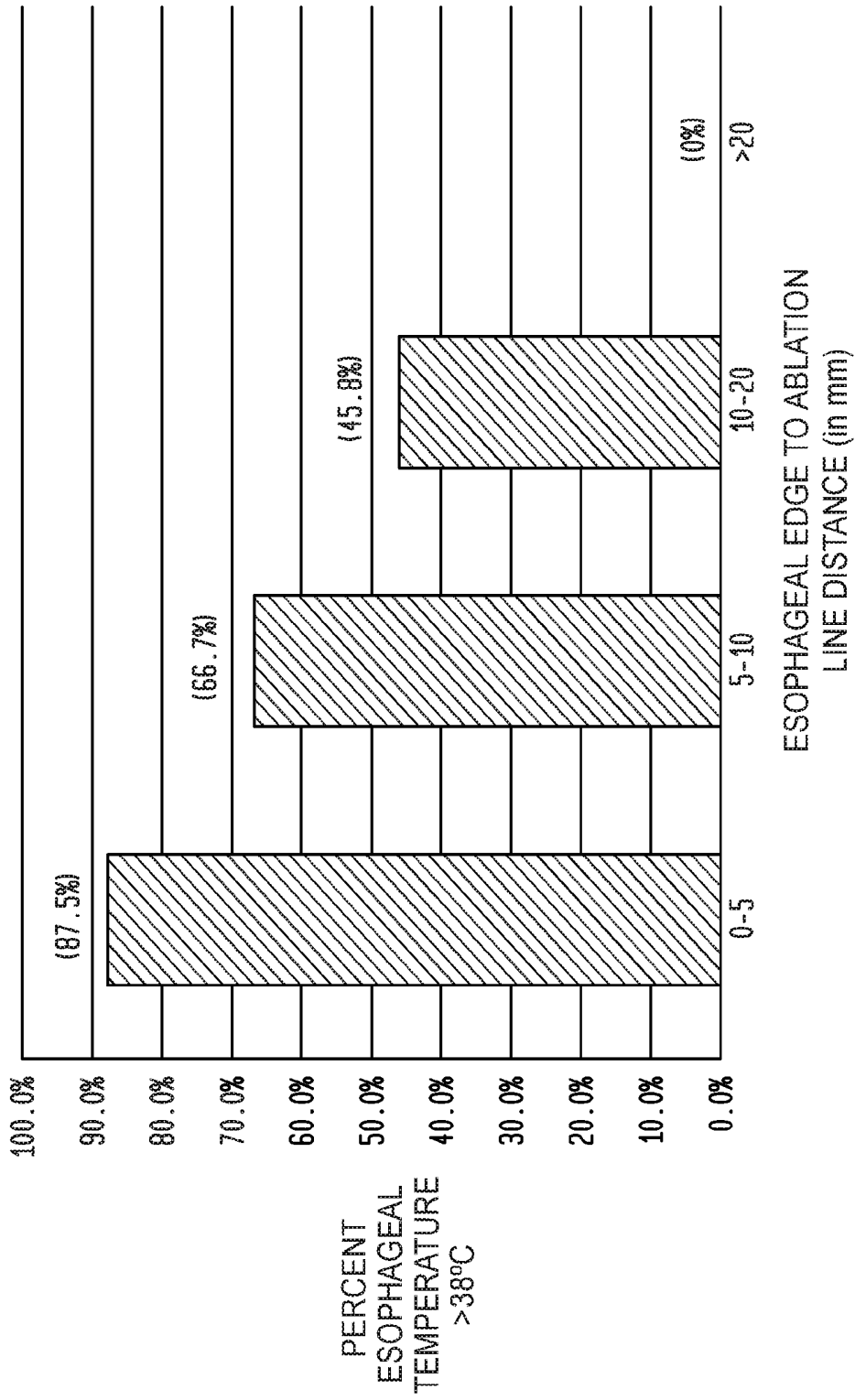

FIG. 1

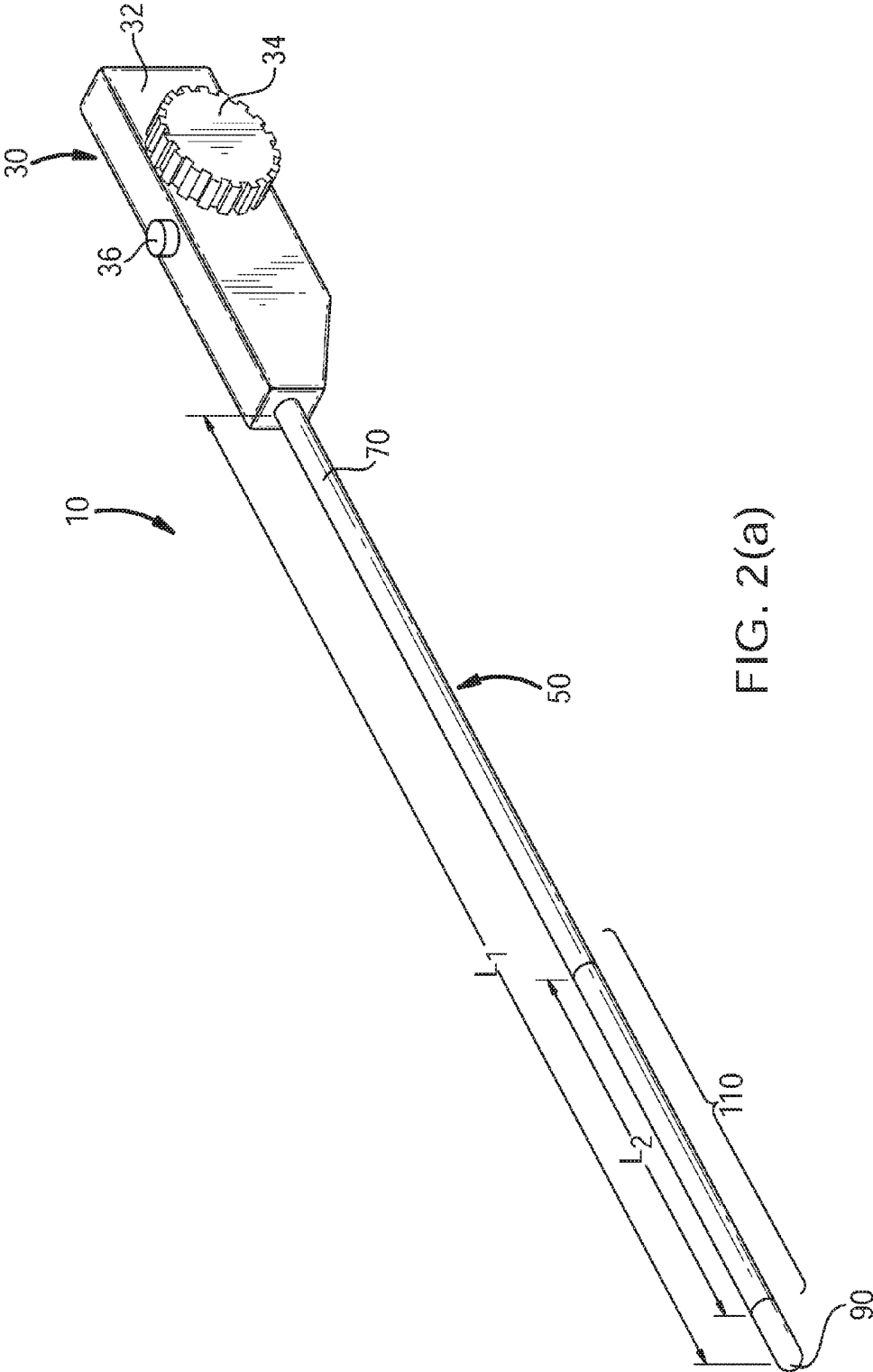

FIG. 2(a)

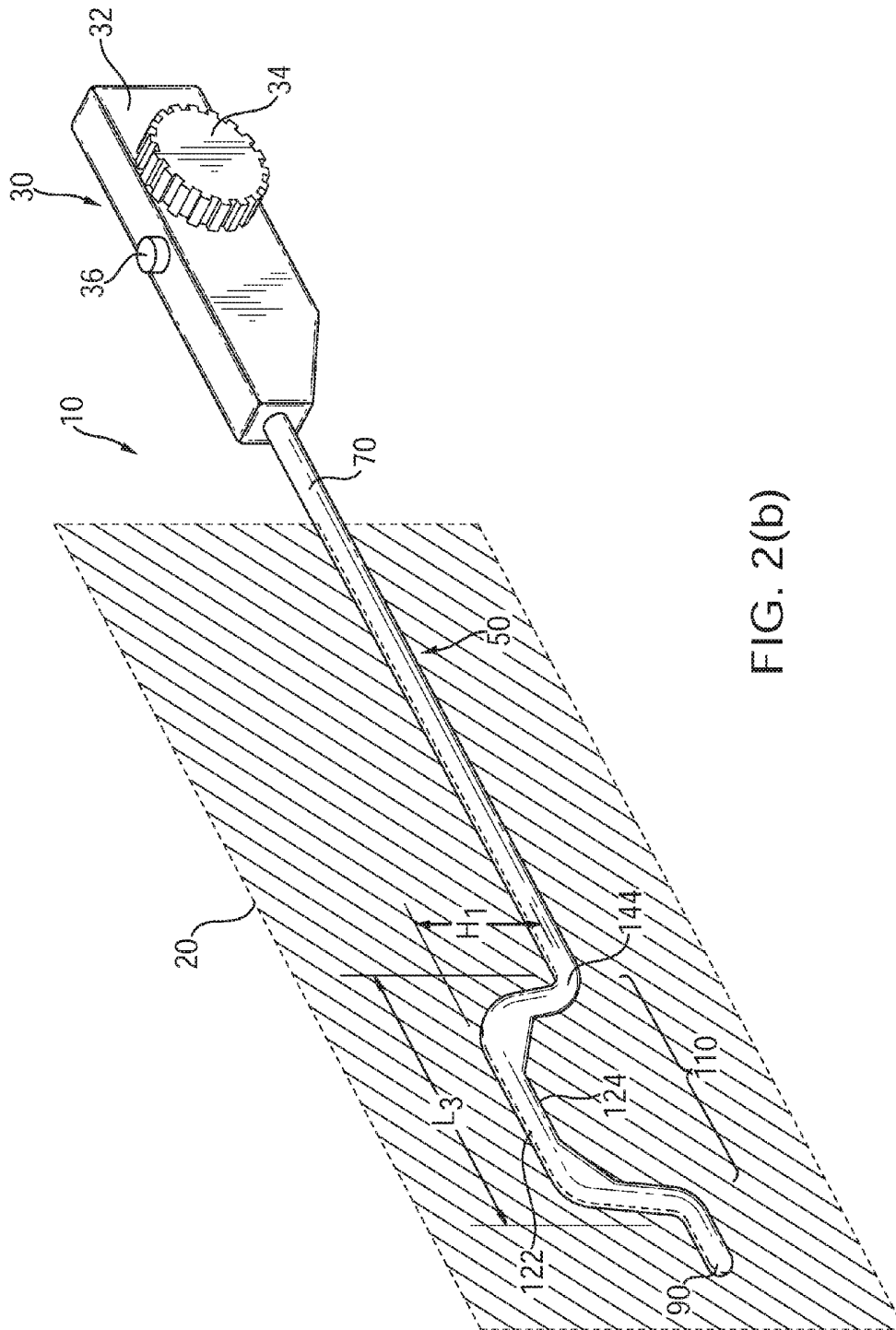

FIG. 2(b)

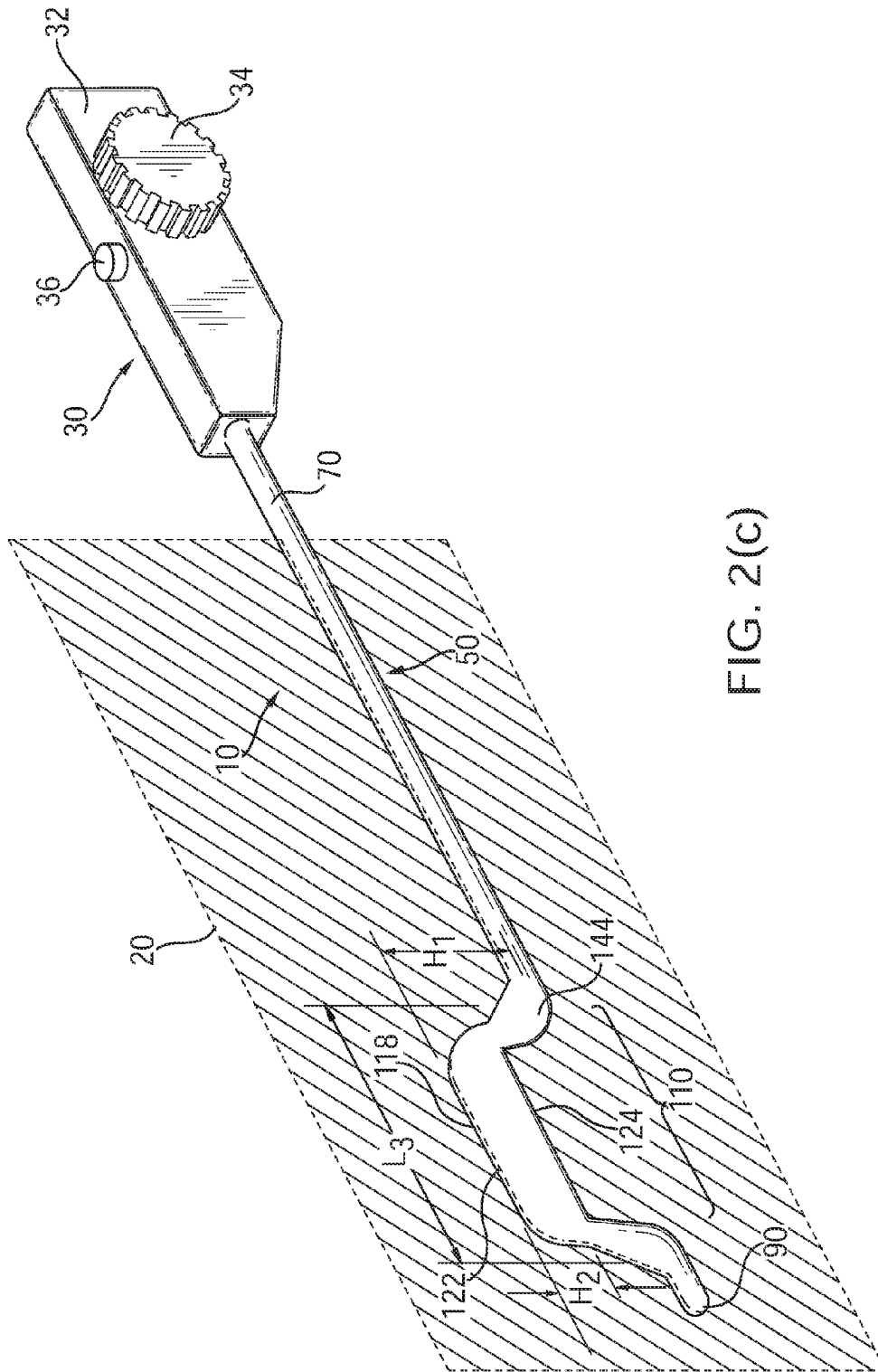

FIG. 2(c)

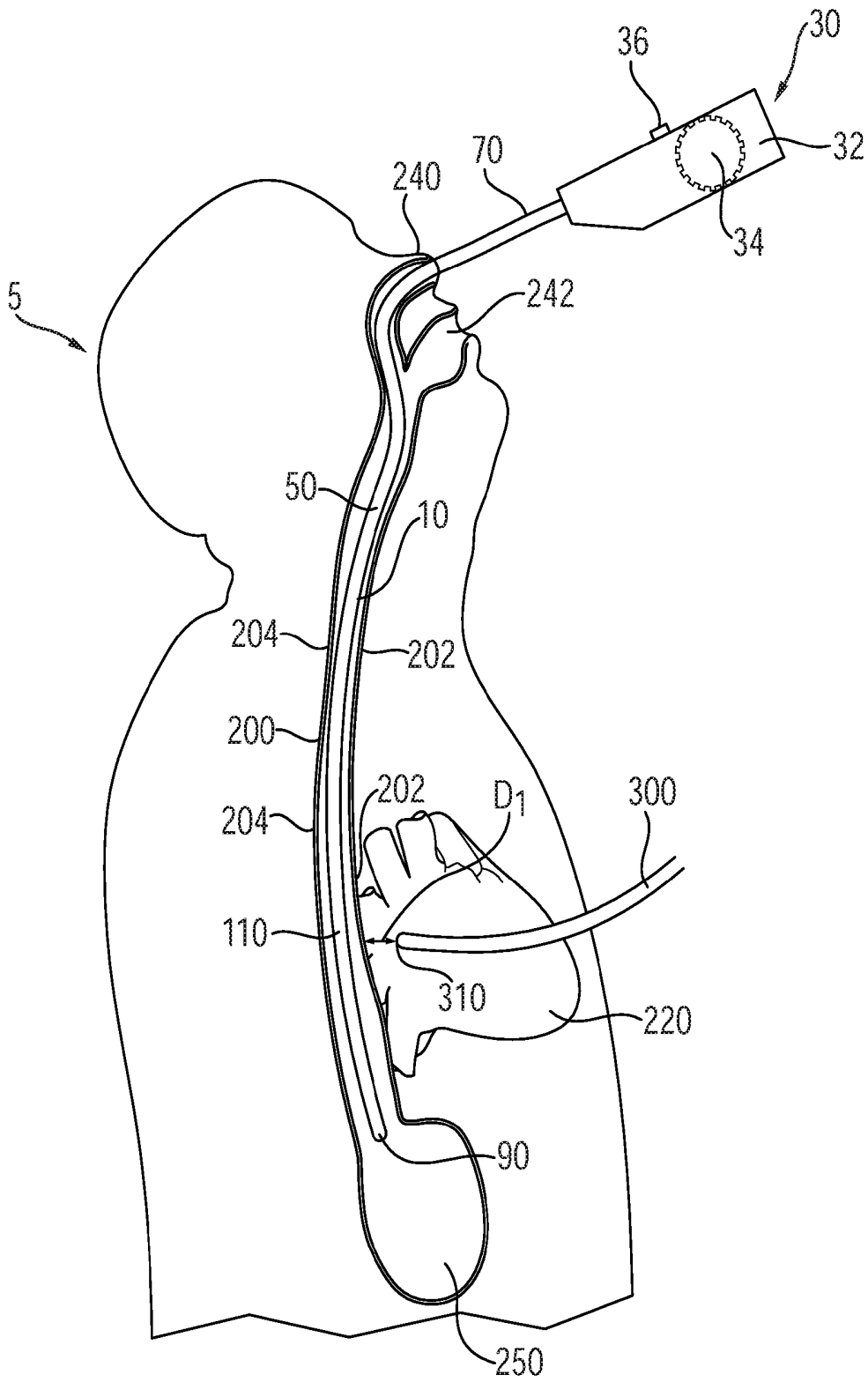

FIG. 3(a)



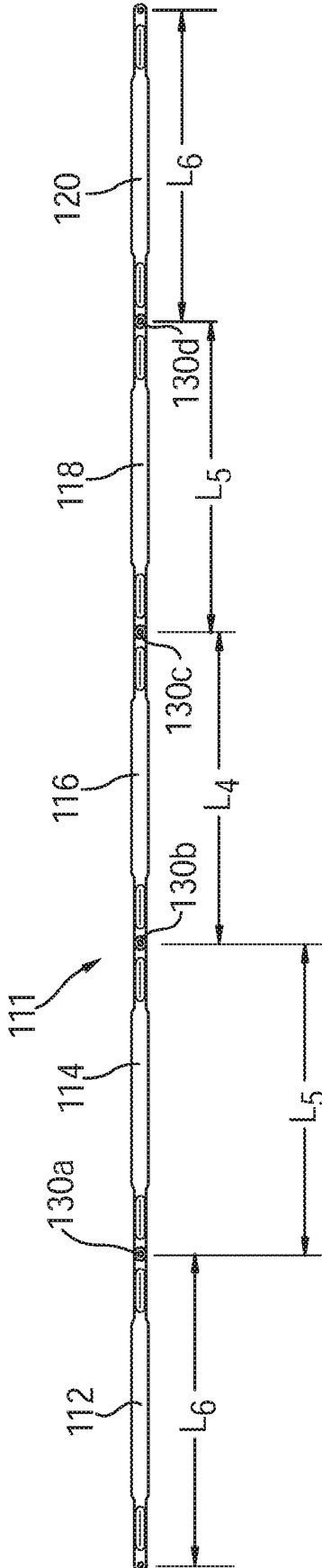

FIG. 4

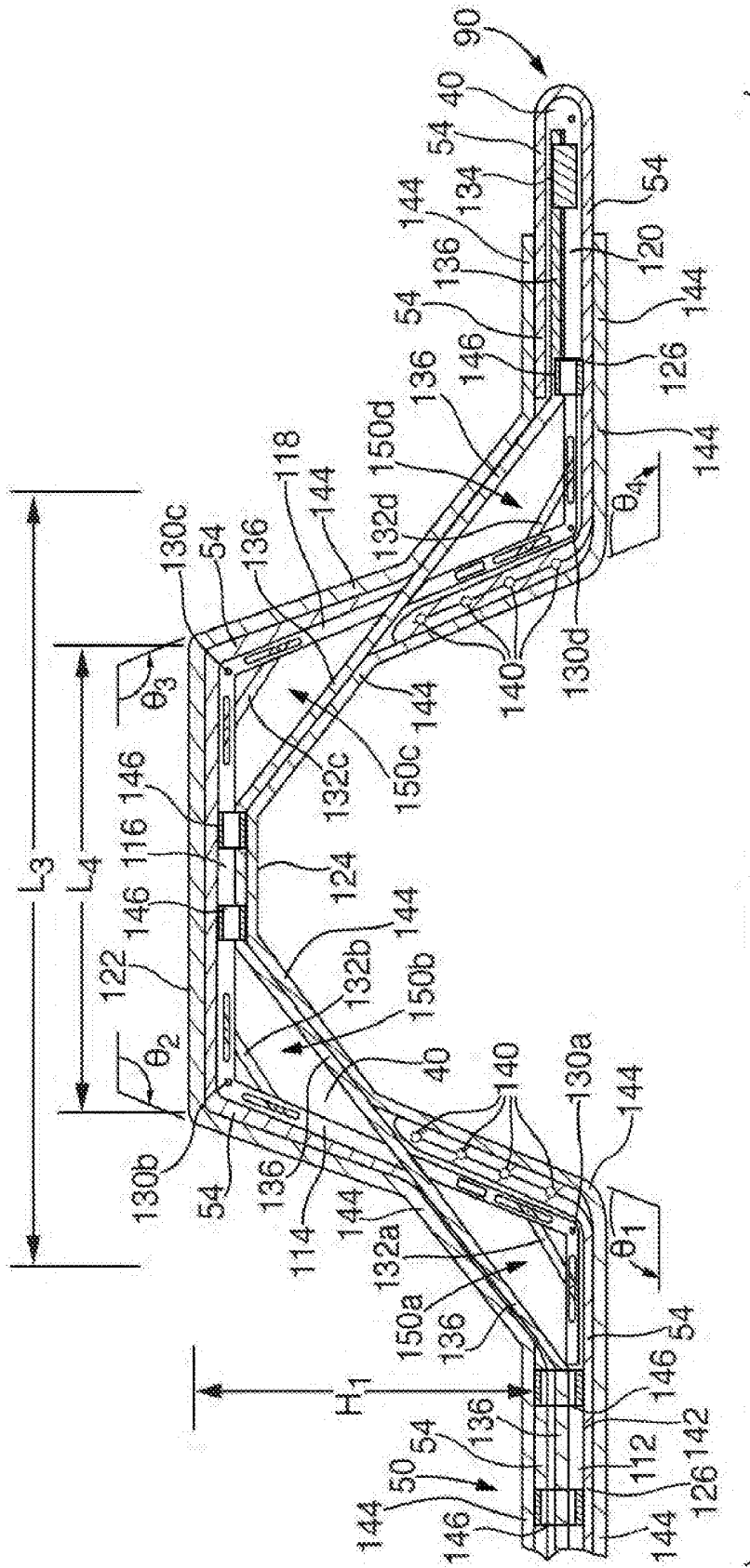

FIG. 5

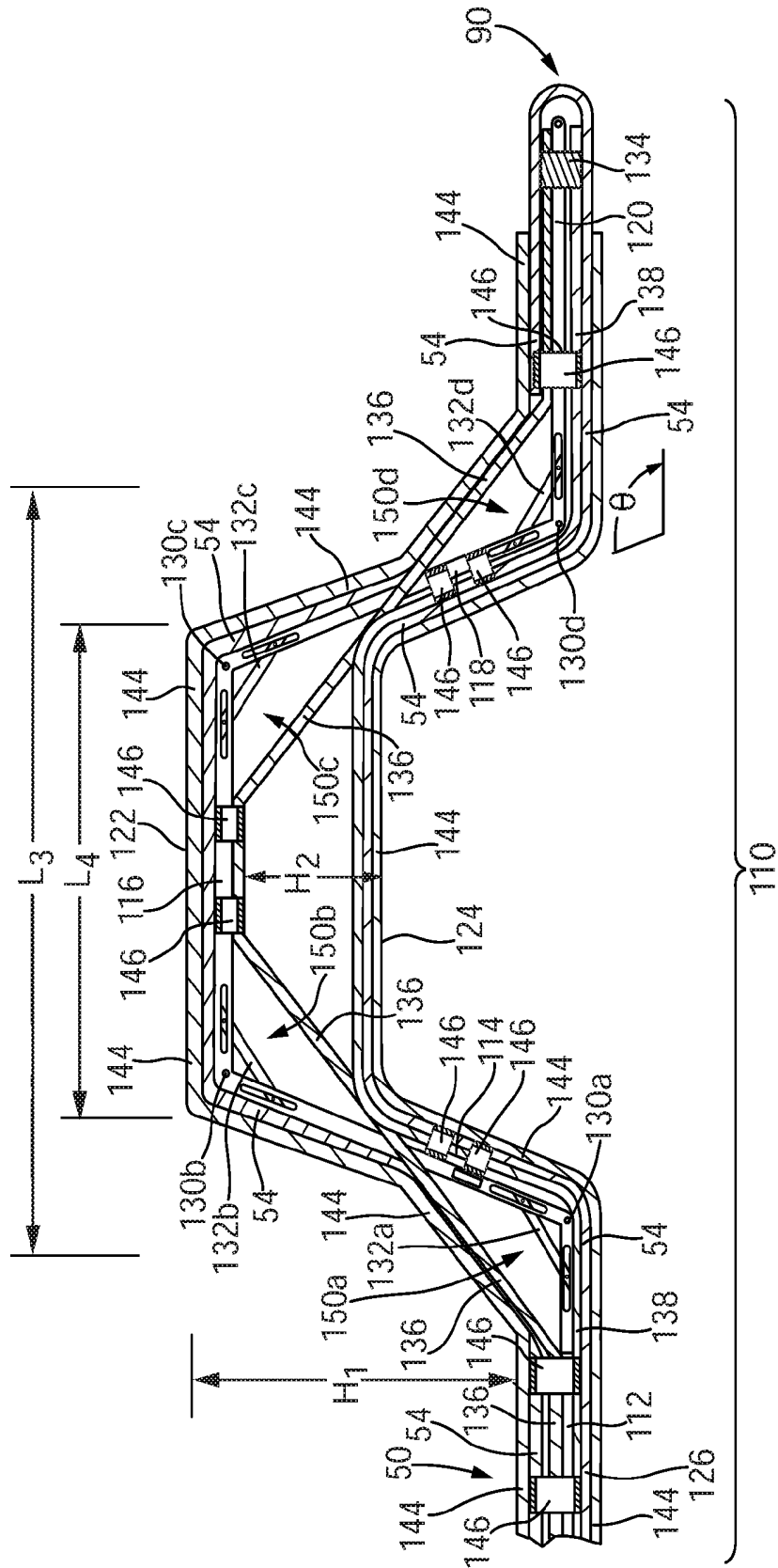
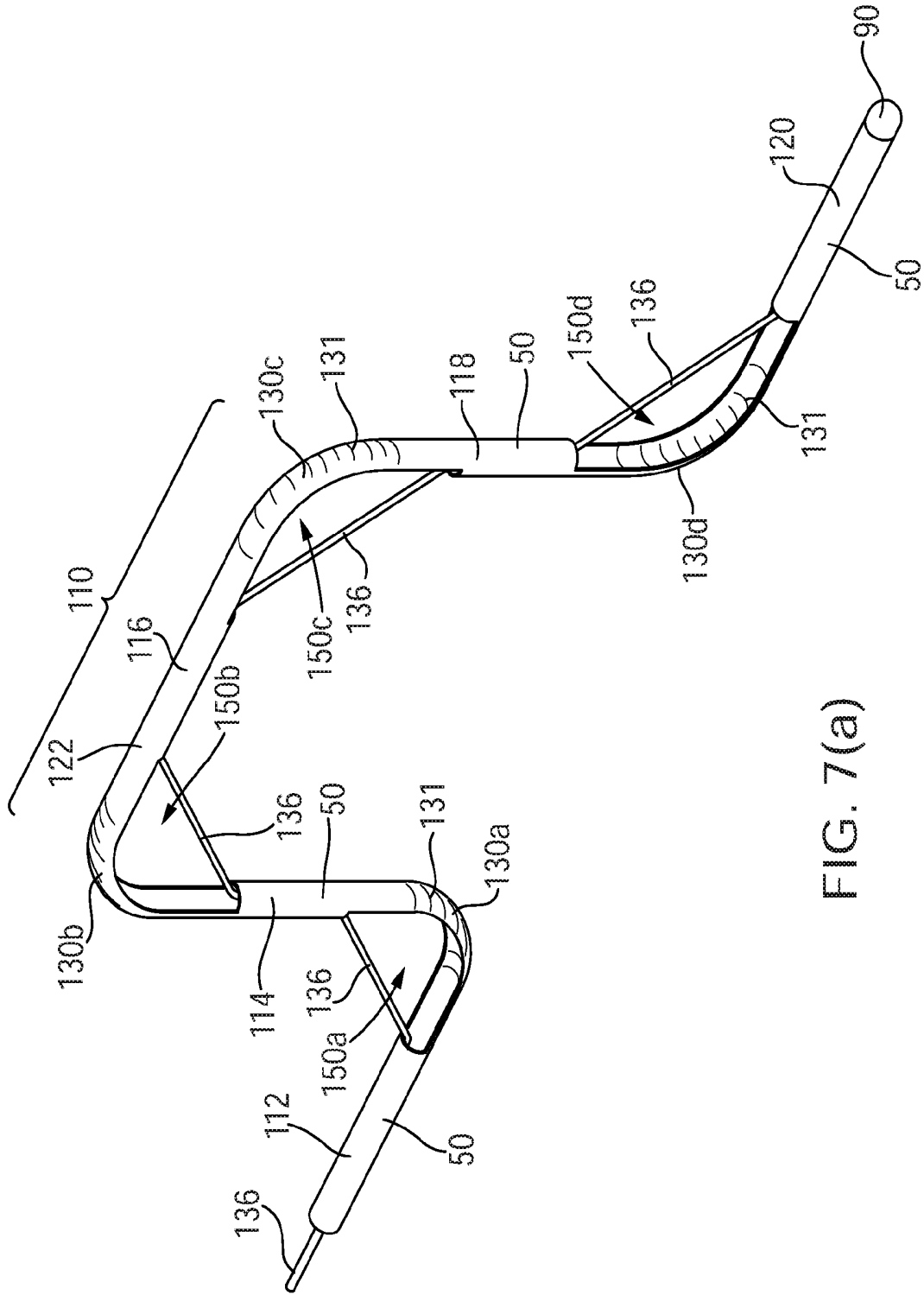

FIG. 6



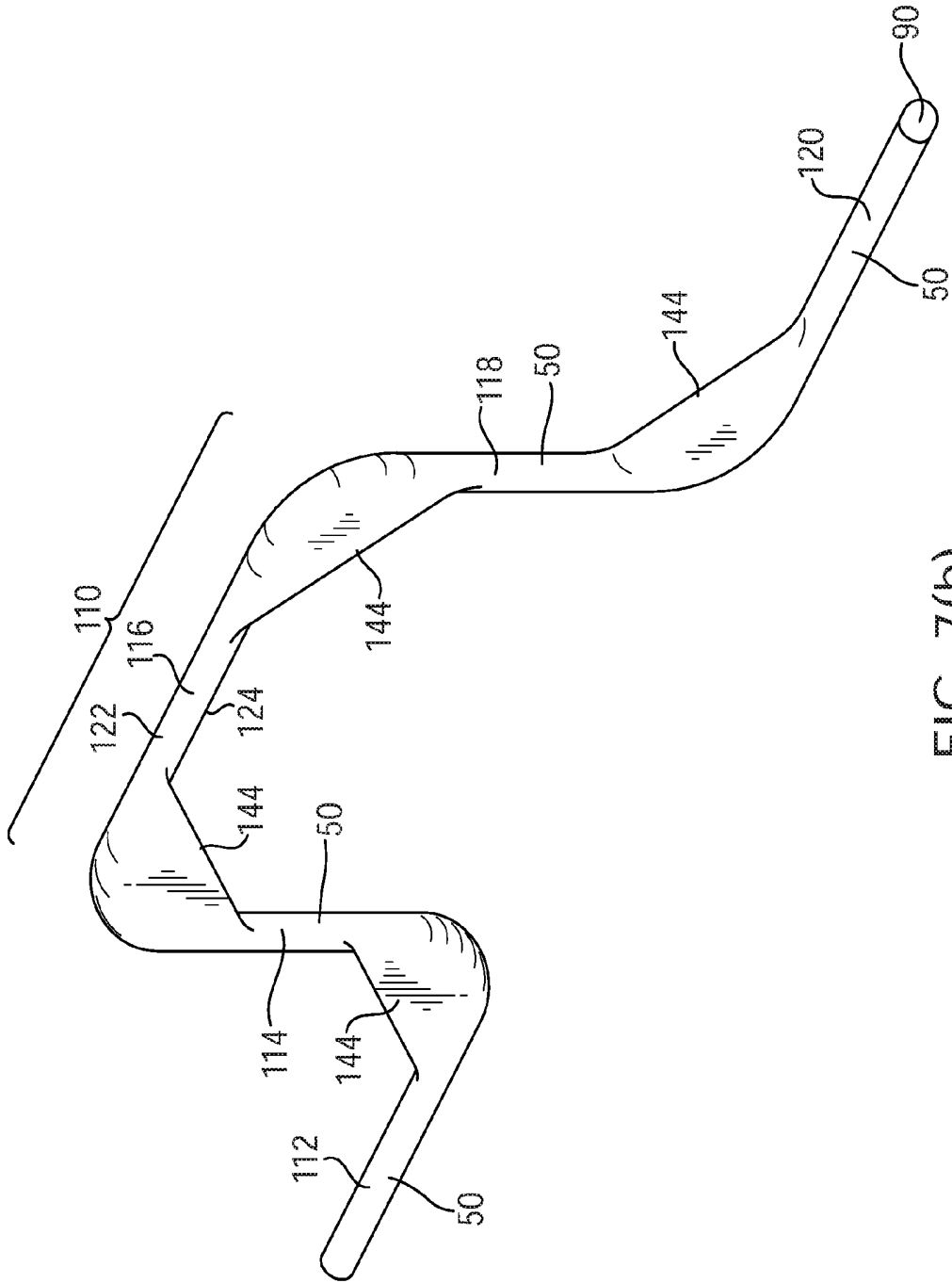

FIG. 7(b)



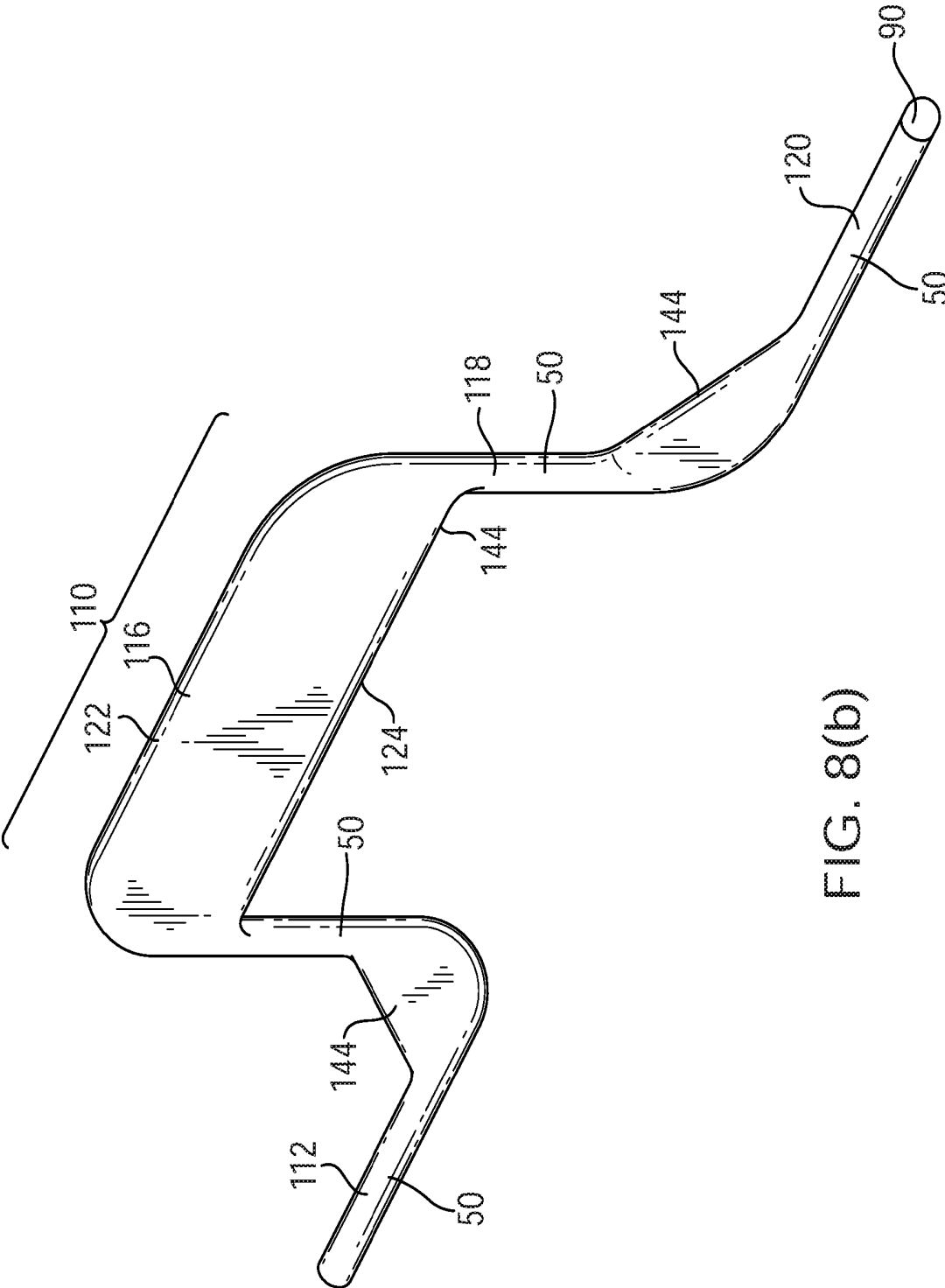

FIG. 8(b)

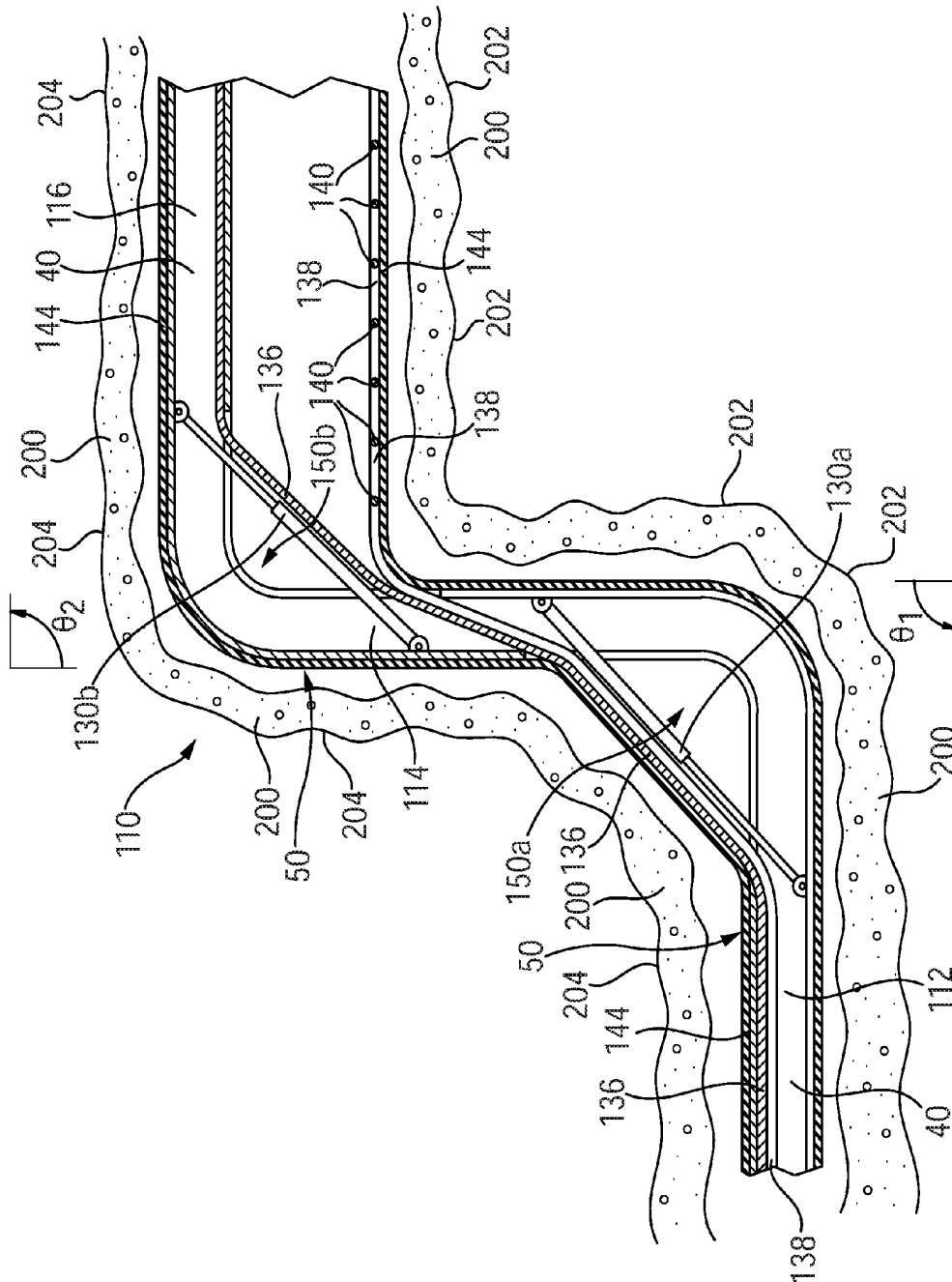

FIG. 8(c)

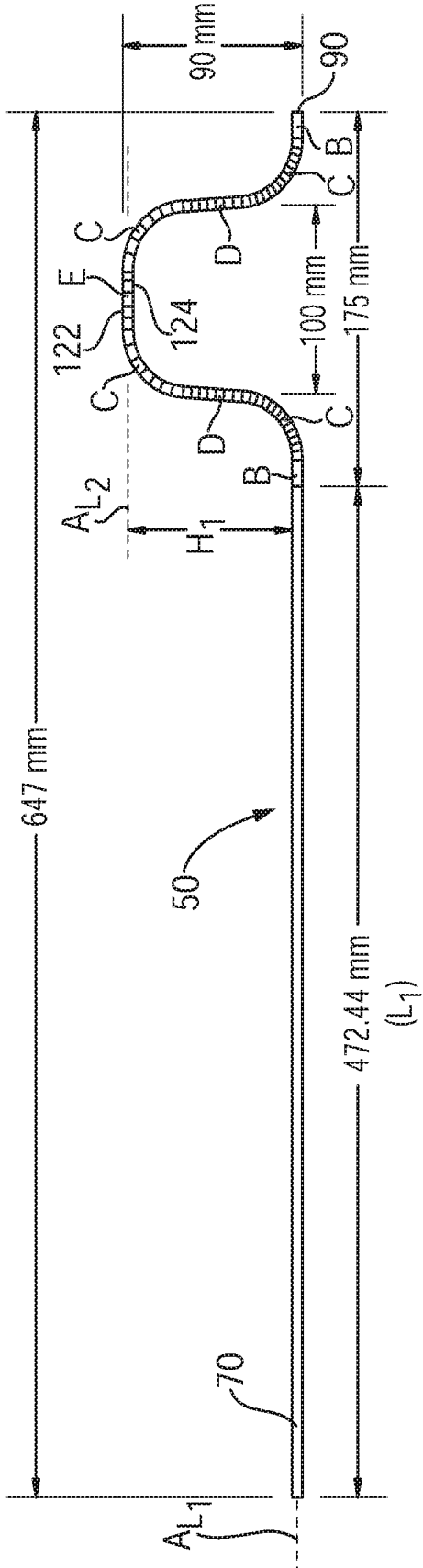

FIG. 9(a)

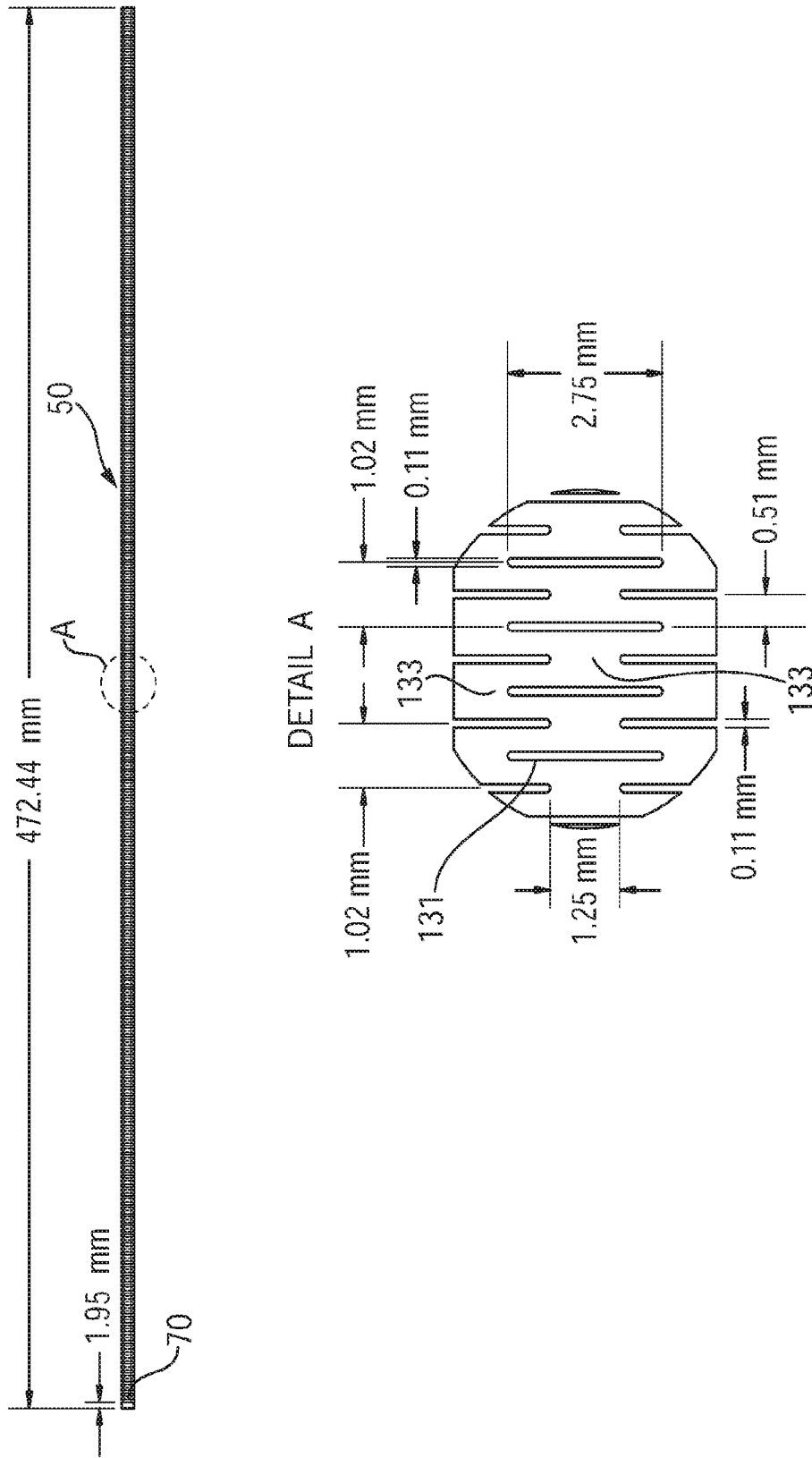

FIG. 9(b)

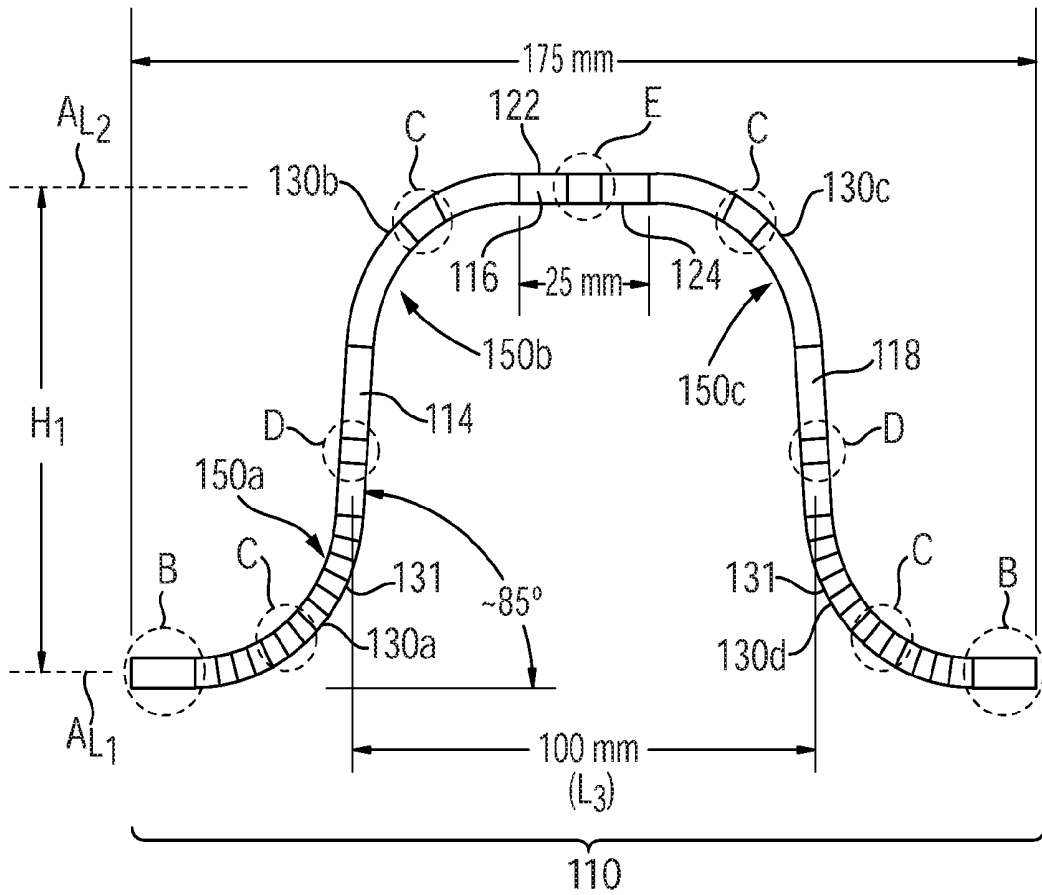

FIG. 9(c)

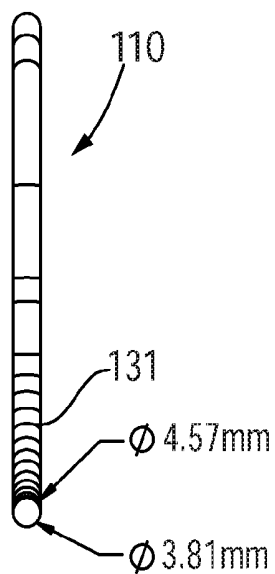
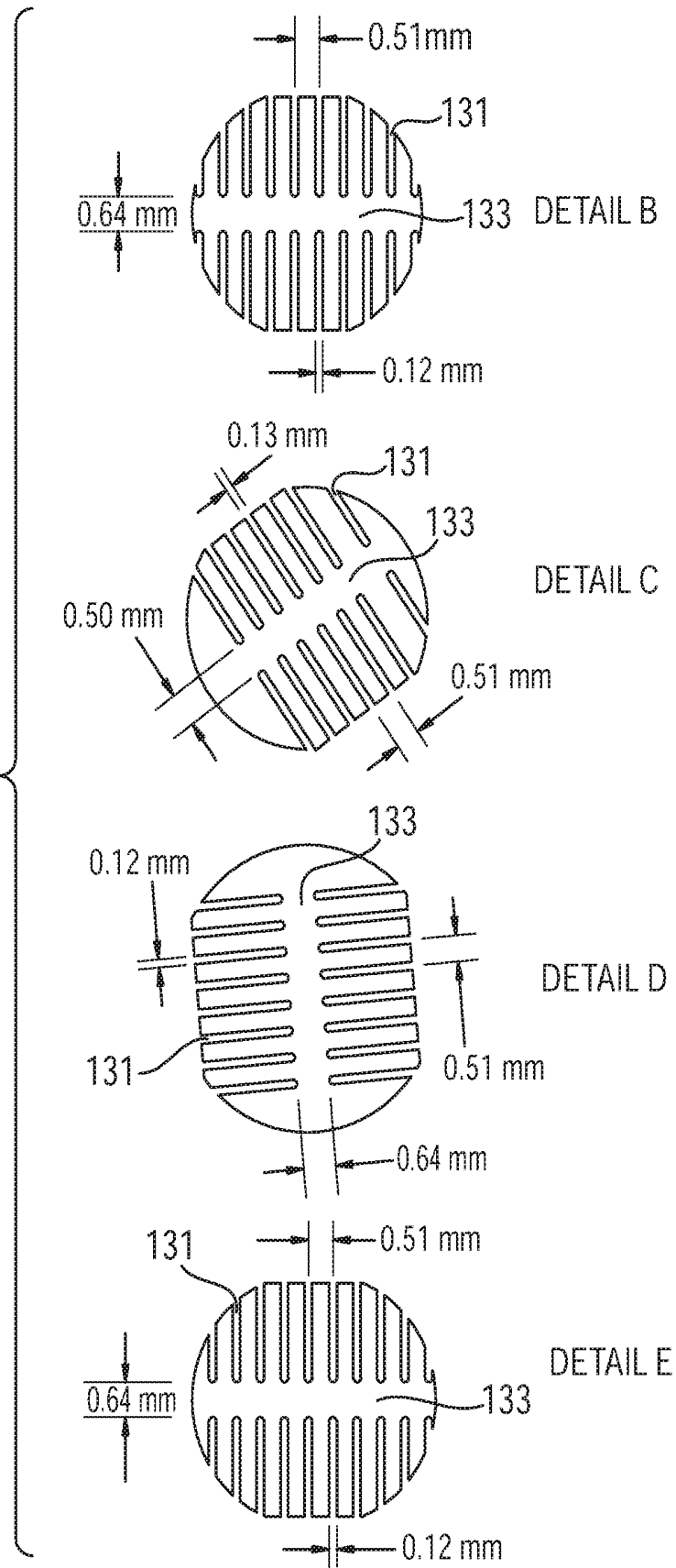
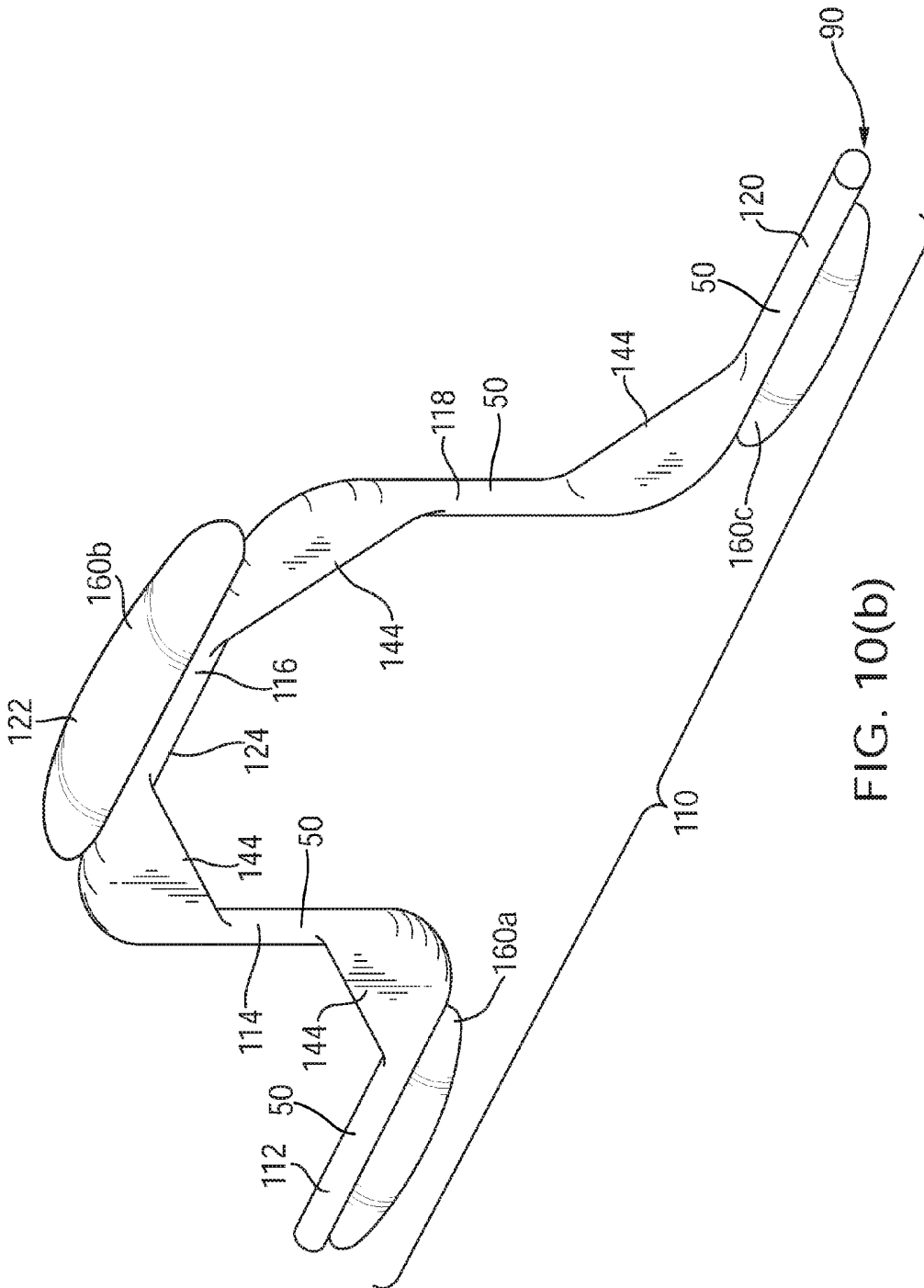

FIG. 9(d)

FIG. 9(e)







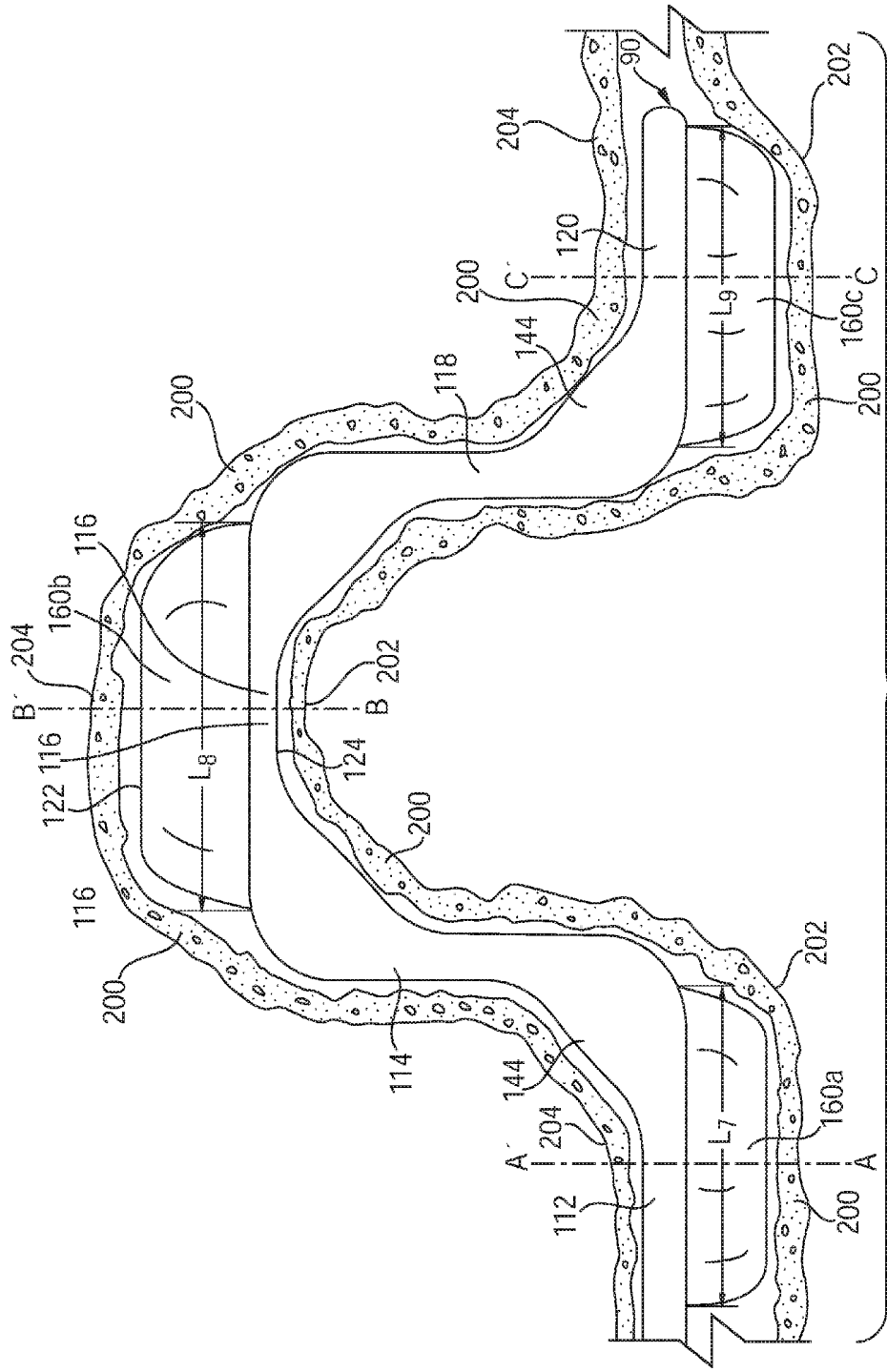

FIG. 10(c)

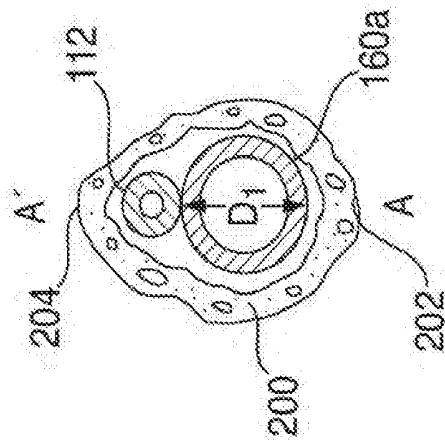

FIG. 10(d)

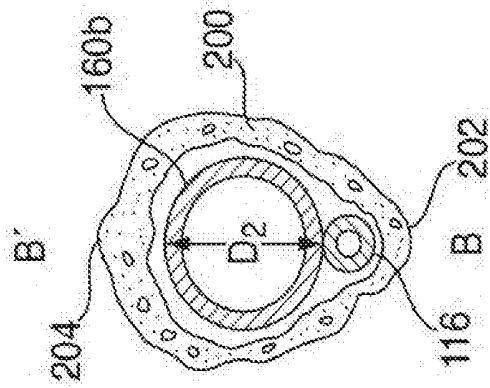

FIG. 10(e)

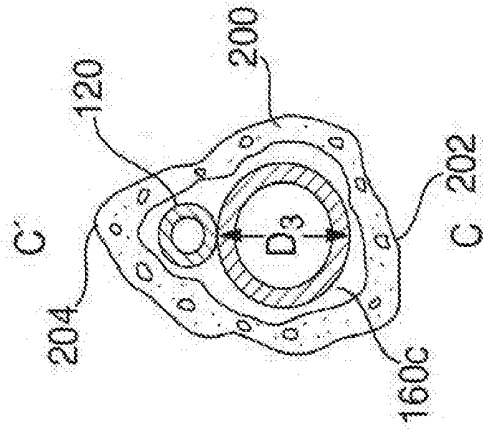
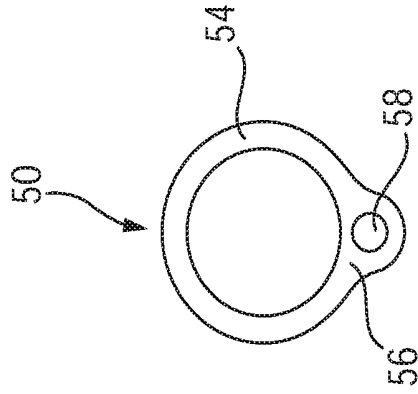
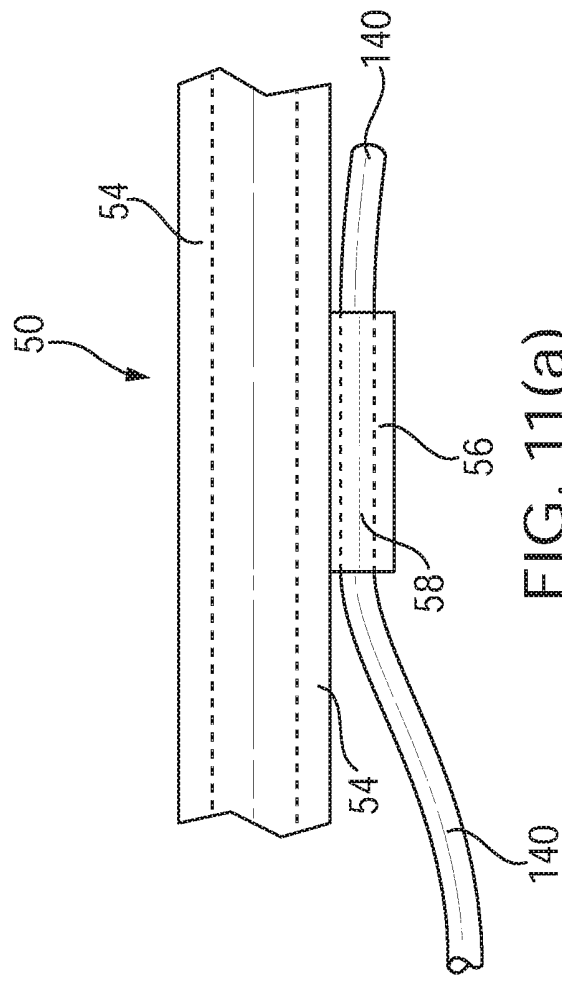

FIG. 10(f)



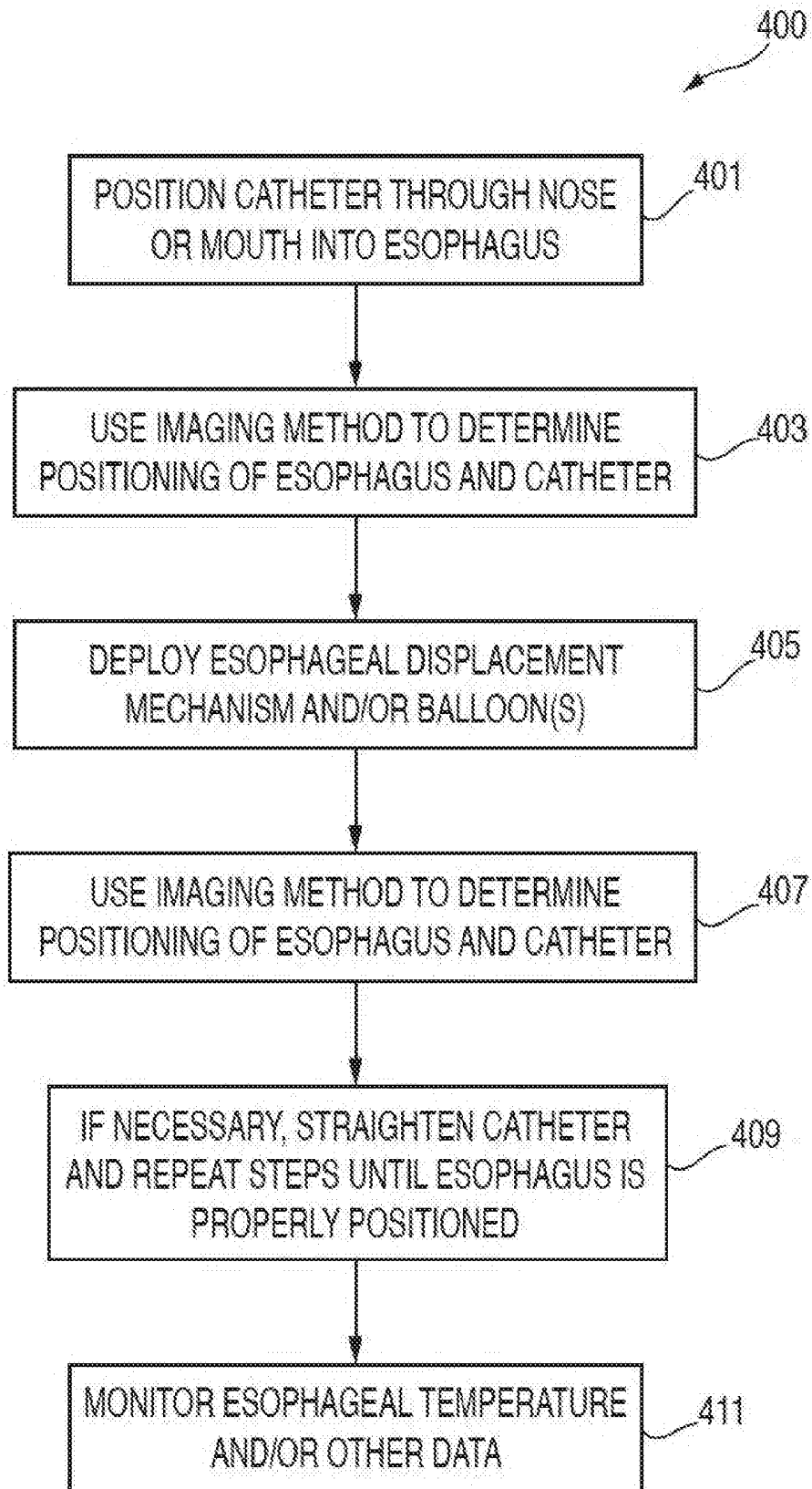

FIG. 12

**SYSTEMS, DEVICES, COMPONENTS AND  
METHODS FOR DISPLACING AND  
REPOSITIONING THE ESOPHAGUS AWAY  
FROM THE HEART DURING ATRIAL  
ABLATION SURGICAL PROCEDURES**

SUMMARY

RELATED APPLICATION

[0001] This application claims priority and other benefits from, and is a continuation-in-part of, U.S. patent application Ser. No. 14/887,313 to Kasic entitled “Systems, Devices, Components and Methods for Displacing and Repositioning the Esophagus Away from the Heart during Atrial Ablation Surgical Procedures” filed on Oct. 19, 2015, now U.S. Pat. No. 9,668,720 issued on Jun. 6, 2017 (“the 720 patent”). The entirety of the ’720 patent is hereby incorporated by reference herein.

FIELD OF THE INVENTION

[0002] Various embodiments of the invention described herein relate to the field of systems, devices, components, and methods for displacing or repositioning a patient’s esophagus away from the patient’s heart during an atrial ablation or other surgical procedure.

BACKGROUND

[0003] Catheter ablation is commonly employed to treat atrial fibrillation, where errant electrical conductivity pathways in a patient’s heart are burned or ablated with the tip of an ablation catheter that is positioned within the patient’s atrium during a cardiac ablation surgical procedure. A significant risk in such a procedure is burning or ablating through a wall of the patient’s atrium and then into the patient’s esophagus, or otherwise damaging or overheating esophageal tissue. Indeed, burning or ablating the patient’s esophagus can result in near-immediate death. See, for example, “Damage to the Esophagus After Atrial Fibrillation Ablation—Just the Tip of the Iceberg? High Prevalence of Mediastinal Changes Diagnosed by Endosonography” to Zellerhoff et al., *Circulation: Arrhythmia and Electrophysiology*, 2010; 3:155-159, Apr. 20, 2010. Zellerhoff et al. describe structural changes in the mediastinum resulting from PV isolation and ablation, which were only visible by endosonography, and which occurred in 27% of the patients studied.

[0004] Mechanical esophageal displacement of the esophagus away from the heart during a cardiac ablation surgical procedure is therefore highly desirable so that in the event a patient’s atrial wall is penetrated during the procedure the esophagus will not be burned or ablated. See “Mechanical Esophageal Displacement during Catheter Ablation for Atrial Fibrillation” by Koruth et al. *Journal of Cardiovascular Electrophysiology*, Vol. 23, No. 2, February, 2012.

[0005] Various devices and methods have been proposed to displace or re-position a patient’s esophagus during atrial ablation surgical procedures, many of which suffer from various shortcomings.

[0006] What is needed is an esophageal displacement or re-positioning device that is relatively quick and easy to use, and that is capable of reliably re-positioning a patient’s esophagus a safe distance away from the patient’s heart during a cardiac ablation surgical procedure.

[0007] In one embodiment, there is provided an esophageal displacement catheter comprising a catheter body having a longitudinal axis associated therewith, the catheter body comprising a distal end, a proximal end, at least one lumen, and a distendable section having sidewalls, the lumen extending between at least portions of the proximal and distal ends, the catheter body being configured to assume an at least partially flexible or limp configuration along at least portions of the longitudinal axis when the catheter body is in a relaxed or non-active configuration, a catheter manipulation mechanism disposed at or near the proximal end of the catheter body, at least a first pulling member disposed at least partially within the catheter and the lumen, the first pulling member comprising a distal portion operably connected to or near a distal end of the catheter body and a proximal portion operably connected to the catheter manipulation mechanism such that a user can tighten and relax the pulling member using the catheter manipulation mechanism, and at least one elastic flexible deformable or distendable member, sheath, layer or covering disposed over at least portions of the distendable section, wherein the distendable section comprises a plurality of substantially rigid sections interconnected by a plurality of joints disposed along the distendable section, the joints and substantially rigid segments being configured to permit the distendable section to deflect away from the longitudinal axis and assume a distended configuration when the first pulling member is pulled or retracted sufficiently far towards the proximal end of the catheter body using the catheter manipulation mechanism, the distendable section further being configured such that portions of the first pulling member extend sufficiently far away from the joints when the first pulling member is in a retracted position to permit the distendable section to assume a deployed and distended configuration, and the at least one flexible deformable or distendable member, sheath or covering is configured to be disposed over and cover the portions of the first pulling member extending away from the joints when the distendable section is the deployed and distended configuration, the catheter being configured to displace and reposition an esophagus of a patient at least 20 mm away from the patient’s heart when the distendable section is in the deployed and distended configuration.

[0008] In another embodiment, there is provided a method of displacing a portion of an esophagus of a patient away from the patient’s heart with an esophageal displacement catheter, the catheter comprising a catheter body having a longitudinal axis associated therewith, the catheter body comprising a distal end, a proximal end, at least one lumen, and a distendable section having sidewalls, the lumen extending between at least portions of the proximal and distal ends, the catheter body being configured to assume an at least partially flexible or limp configuration along at least portions of the longitudinal axis when the catheter body is in a relaxed or non-active configuration, a catheter manipulation mechanism disposed at or near the proximal end of the catheter body, at least a first pulling member disposed at least partially within the catheter and the lumen and comprising a distal portion operably connected to or near a distal end of the catheter body and a proximal portion operably connected to the catheter manipulation mechanism such that a user can tighten and relax the pulling member using the catheter manipulation mechanism, and at least one elastic

flexible deformable or distendable member, sheath, layer or covering disposed over at least portions of the distendable section, the distendable section comprising a plurality of substantially rigid sections interconnected by a plurality of joints disposed along the distendable section, the joints and substantially rigid segments being configured to permit the distendable section to deflect away from the longitudinal axis and assume a distended configuration when the first pulling member is retracted or pulled sufficiently far towards the proximal end of the catheter body using the catheter manipulation mechanism, the distendable section further being configured such that portions of the first pulling member extend sufficiently far away from the joints when the first pulling member is in a retracted position to permit the distendable section to assume a deployed and distended configuration, and the at least one flexible deformable or distendable member, sheath or covering is configured to be disposed over and cover the portions of the first pulling member extending away from the joints when the distendable section is the deployed and distended configuration, the catheter being configured to displace and reposition an esophagus of a patient at least 20 mm away from the patient's heart when the distendable section is in the deployed and distended configuration, the method comprising inserting the distal end of the catheter body in the patient's nose or mouth, inserting and positioning the distal end of the catheter into the patient's esophagus, and causing the first pulling member to retract in the direction of the proximal end of the catheter body such that the distendable section is deployed, the distendable section assumes the distended configuration, and the distendable section positions the patient's esophagus at least 20 mm away from the patient's heart.

[0009] Further embodiments are disclosed herein or will become apparent to those skilled in the art after having read and understood the specification and drawings hereof.

#### BRIEF DESCRIPTION OF THE DRAWINGS

[0010] Different aspects of the various embodiments will become apparent from the following specification, drawings and claims in which:

[0011] FIG. 1 shows the relationship between esophageal temperature and esophageal edge to ablation line distance in millimeters;

[0012] FIG. 2(a) shows a top perspective view of one embodiment of an esophageal displacement and repositioning catheter 10 in a resting or non-distended or non-deployed position;

[0013] FIG. 2(b) shows a top perspective view of the esophageal displacement and repositioning catheter 10 of FIG. 2(a) in an active, distended or deployed configuration;

[0014] FIG. 2(c) shows a top perspective view of another embodiment of an esophageal displacement and repositioning catheter 10 in an active, distended or deployed configuration;

[0015] FIG. 3(a) shows a cross-sectional view of one embodiment of an esophageal displacement and repositioning catheter 10 positioned in esophagus 200 of patient 5, where catheter 10 is in a resting, or on-distended or non-deployed configuration;

[0016] FIG. 3(b) shows a cross-sectional view of the esophageal displacement and repositioning catheter 10 of

FIG. 3 positioned in esophagus 200 of patient 5, where catheter 10 is in an active, distended or deployed configuration;

[0017] FIG. 4 shows a side view of one embodiment of a portion 111 of a distendable section 110 of an esophageal displacement and repositioning catheter 10;

[0018] FIG. 5 shows a side cross-sectional view of one embodiment of a distendable section 110 of an esophageal displacement and repositioning catheter 10;

[0019] FIG. 6 shows a side cross-sectional view of another embodiment of a distendable section 110 of an esophageal displacement and repositioning catheter 10;

[0020] FIG. 7(a) shows a top perspective view of yet another embodiment of a distendable section 110 of an esophageal displacement and repositioning catheter 10;

[0021] FIG. 7(b) shows distendable section 110 of esophageal displacement and repositioning catheter 10 of FIG. 8(a) having an elastic, flexible or distendable sheath 144 positioned thereover;

[0022] FIG. 8(a) shows a top perspective view of still another embodiment of a distendable section 110 of an esophageal displacement and repositioning catheter 10;

[0023] FIG. 8(b) shows distendable section 110 of esophageal displacement and repositioning catheter 10 of FIG. 8(a) having an elastic, flexible or distendable sheath 144 positioned thereover;

[0024] FIG. 8(c) shows a cross-sectional view of a portion of another embodiment of a distendable section of an esophageal displacement and repositioning catheter;

[0025] FIG. 9(a) shows a side view of still another embodiment of catheter body 50, proximal end 70, distal end 90 and distendable section 110 of an esophageal displacement and repositioning catheter 10;

[0026] FIG. 9(b) shows a side view of catheter body 50 of esophageal displacement and repositioning catheter 10 shown in FIG. 9(a), including detail A thereof;

[0027] FIG. 9(c) shows a side view of distendable section 110 of esophageal displacement and repositioning catheter 10 shown in FIG. 9(a);

[0028] FIG. 9(d) shows an end view of distendable section 110 of esophageal displacement and repositioning catheter 10 shown in FIG. 9(c);

[0029] FIG. 9(e) shows details C, D, E and F of distendable section 110 of esophageal displacement and repositioning catheter 10 shown in FIGS. 9(c) and 9(d);

[0030] FIG. 10(a) shows a top perspective view of still another embodiment of a distendable section 110 of an esophageal displacement and repositioning catheter 10 comprising balloons 160a, 160b and 160c in non-deployed or non-inflated states;

[0031] FIG. 10(b) shows distendable section 110 of esophageal displacement and repositioning catheter 10 of FIG. 10(a) with balloons 160a, 160b and 160c in deployed or inflated states;

[0032] FIG. 10(c) shows distendable section 110 of esophageal displacement and repositioning catheter 10 of FIG. 10(b) with balloons 160a, 160b and 160c in deployed or inflated states positioned in a patient 5's esophagus;

[0033] FIGS. 10(d), 10(e) and 10(f) show cross-sectional views of some components and elements of distendable section 110 through sections A-A', B-B' and C-C', respectively, of FIG. 10(c);

**[0034]** FIGS. 11(a) and 11(b) show side and end cross-sectional views of catheter body 50 and sensor coupling mechanism 56;

**[0035]** FIG. 12 shows one embodiment of method 400 for using an esophageal displacement and repositioning catheter.

**[0036]** The drawings are not necessarily to scale. Like numbers refer to like parts or steps throughout the drawings.

#### DETAILED DESCRIPTIONS OF SOME EMBODIMENTS

**[0037]** Described herein are various embodiments of systems, devices, components and methods for repositioning and displacing a patient's esophagus away from the patient's heart during an atrial ablation surgical procedure.

**[0038]** The esophagus is in close proximity to the posterior wall of the left atrium, which renders it susceptible to thermal injury during radiofrequency (RF) ablation procedures for atrial fibrillation (AF). Real-time assessment of esophageal position and temperature ( $T^{\circ}$ ) during pulmonary vein (PV) isolation has not been extensively explored. See "Computational Method to Predict Esophageal Temperature Elevations During Pulmonary Vein Isolation" to Musat, M. D. et al., Pacing and Clinical Electrophysiology, Volume 33, Issue 10, pages 1239-1248, October 2010. Atrial fibrillation ablation (AF ablation) can include isolation of the left or right pulmonary veins by applying ablation energy at their junction with the atrium.

**[0039]** The Centers for Disease Control (CDC) estimates that 12 million people in the US have atrial fibrillation (AF). Worldwide, about 260,000 people are treated by AF ablation each year. In up to 1% of these cases, atria-esophageal fistulas develop because of overheating and damage that have occurred to the esophagus during the AF ablation procedure. Overheating and damage to the esophagus can occur when heart tissue is burned or ablated through during the AF ablation procedure. Between 70 and 100% of patients who develop atrio-esophageal fistulas as a consequence of AF ablation die. Moreover, esophageal injury of some sort occurs in up to 36% of AF ablation procedures. See "Computed Tomographic Analysis of the Anatomy of the Left Atrium" to Lemola et al., Circulation, 2004; and "Esophageal Injury and Temperature Monitoring" to Singh et al., Circulation, October, 2008. See also Zellerhoff et al., infra.

**[0040]** Temperature sensors disposed in the esophagus have been used with varying success during AF ablation procedures, but can be unwieldy, slow to react, have small sensing areas, or be located away from the critically important trailing edge of the esophagus, which is located closest to the site where AF ablation occurs and is therefore most susceptible to damage and overheating.

**[0041]** Various studies have indicated there is little to no heating of the esophagus during an AF ablation procedure when the esophagus is repositioned or displaced at least 20 mm away from the ablation site. See, for example, "Effectiveness of Esophageal Mechanical Deviation during AF Ablation," C. Palaniswamy et al., PO01-83, Heart Rhythm Society, May 13, 2015.

**[0042]** As a result, solutions have focused on moving the esophagus away from the patient's heart during AF ablation procedures using devices such as wires, balloons and catheters. Such devices, however, often suffer from one or more problems, including excessive cost, an inability to achieve the amount of deflection, displacement or repositioning of

the esophagus away from the heart required to prevent burning damage or injury to the esophagus, trauma to the oropharynx, and/or an inability to rotate or reposition, or difficulty in rotating or repositioning, the device in the esophagus once it has been inserted in the esophagus and deployed. For example, many balloon- and catheter-based devices are incapable of transmitting torque efficiently or adequately between the proximal and distal ends thereof if fluoroscopic or other suitable imaging techniques reveal that the device must be rotated in the esophagus to achieve the desired amount of esophageal displacement away from the heart. Moreover, the location of the trailing edge of the esophagus (which is closest to the ablation site and therefore most susceptible to burning or injury) is typically not taken into account by the various esophageal displacement devices that have been developed. See "Mechanical Esophageal Displacement During Catheter Ablation for Atrial Fibrillation," J. Koruth et al., Journal of Cardiovascular Electrophysiology, Volume 23, Issue 2, pages 147-154, February 2012.

**[0043]** The various embodiments disclosed and described herein provide solutions to at least some of the problems outlined above.

**[0044]** Referring now to FIG. 1, there are shown measured relationships between esophageal temperature and an esophageal edge-to-ablation line distance in millimeters. FIG. 1 is adapted from C. Palaniswamy et al., Heart Rhythm Scientific Sessions, 2015, in Boston, Mass. (see above), and illustrates the importance of re-positioning or displacing the esophagus, generally in a lateral direction instead of a posterior direction, and typically 20 mm or more away from the ablation site during an AF ablation procedure. FIG. 1 illustrates the percentage of patients where the edge of the esophagus was heated to a temperature exceeding 38 degrees Celsius as a function of distance between the esophagus and the ablation site. As shown, no patients experienced heating of the edge of the esophagus above 38 degrees Celsius when the distance between the edge of the esophagus and the ablation site exceeded 20 mm.

**[0045]** FIG. 2(a) shows a top perspective view of one embodiment of an esophageal displacement and repositioning catheter 10 in a resting or non-distended position. As shown, catheter 10 comprises catheter body 50 having proximal end 70 and distal end 90, distendable section 110 of catheter body 50, and catheter manipulation handle 30. Catheter body 50 is further characterized in having overall length L1, and length L3 associated with distendable section 110. In one embodiment, catheter manipulation mechanism or handle 30 comprises housing 32, pulling member tightening and loosening dial 34, and ratchet locking and unlocking button 36. Other types of pulling member tightening and loosening mechanisms known to those skilled in the art are also contemplated, such as triggers, levers, and so on.

**[0046]** FIG. 2(b) shows a top perspective view of esophageal displacement and repositioning catheter 10 of FIG. 2(b), where distendable section 110 is in an active or distended position, and where a user or health care provider has employed handle 30 and dial 34 to retract a first pulling member 136 (not shown in FIGS. 2(a) through 2(c), but described in further detail below and in other Figures) disposed within catheter body 50 thereby to cause distendable section 110 to assume the distended configuration shown in FIG. 2(b). As shown, distendable section 110 comprises a leading edge 122, a trailing edge 124, a first

height H1, a length L3, and an elastic, flexible, stretchable, and/or distendable member, sheath, covering, or outer layer 144 disposed over at least portions of distendable section 110, more about which is said below.

[0047] Catheter body 50 of FIGS. 2(a) through 2(c) also comprises at least a first lumen 40 (also not shown in FIGS. 2(a) through 2(c), but described in further detail below and in other Figures), which is configured to accommodate first pulling member 136, and which extends between at least portions of proximal and distal ends 70 and 90. In one embodiment, the at least first pulling member 136 is disposed at least partially within catheter body 50 and lumen 40. A plurality of substantially rigid segments located in or on a distendable section of catheter 10, where the segments are serially connected to one another by flexible joints, are disposed in distendable section 110 (more about which is said below and shown in other Figures). In one embodiment, each of such segments is rotatable through a prescribed range of angles, and the segments are configured to rotate within substantially a same plane thereby to transmit rotational torque efficiently through distendable section 110. Other rigid sections can be connected proximally from distendable section 110 to handle 30 or proximal end 70 thereby to transmit rotational torque efficiently from proximal end 70 to distal end 90 through distendable catheter body 50.

[0048] Additionally, shown in FIGS. 2(b) and 2(c) is imaginary or single plane 20, which bisects catheter body 50 and distendable section 110 when distendable section 110 is distended, deployed or activated. distendable section 110 comprises a plurality joints and is configured to deflect away from a longitudinal axis associated with the remaining undeflected portion of catheter body 50. In one embodiment of the distended configuration, distendable section 110 bends and deflects substantially within single plane 20 along the plurality of joints when pulling member 136 is pulled towards proximal end 70 of catheter body 50. In one embodiment, distendable section 110 and catheter body 50 may further be configured to rotate substantially within single plane 20 when the proximal end 70 of catheter body 50 or catheter manipulation mechanism 30 is rotated by a user. In one embodiment, catheter body 50 is configured such that distendable section 110 is configured to assume a distended configuration (shown in FIGS. 2(b) and 2(c)) suitable for displacing and repositioning an esophagus of a patient a suitable distance away from the patient's heart (e.g., 20 mm or more away from the patient's heart) when the pulling member is in an active or distended position within lumen 40 and catheter body 50 as pulling member 136 is tightened, for example, by the user manipulating the catheter manipulation mechanism or handle 30. In addition, and in one embodiment, catheter 50 is configured such that a torsional and rotational force applied to proximal end 70 of catheter body 50 or catheter manipulation mechanism 30 by the user results in a rotation of proximal end 70 of catheter body 50 through a prescribed angle determined by the user, and may also be configured such that torsional force is transmitted efficiently through catheter body 50 and distendable section 110 such that distendable section 110 also rotates substantially through the prescribed angle when the torsional and rotational force is applied by the user. In some embodiments, distendable section 110 may be configured to assume a distended configuration suitable for displacing and repositioning an esophagus of a patient about 20

mm, about 25 mm, about 30 mm, about 35 mm, and/or about 40 mm away from the patient's heart). Other distances D2 away from the heart are also contemplated (see, e.g., FIG. 3(b)).

[0049] Thus, in the embodiments shown in FIGS. 2(a) through 2(c), catheter 10 is configured to be substantially straight and/or at least partially flexible or limp between proximal and distal ends 70 and 90 when first pulling member 136 is in a resting or non-distension position within lumen 40, and catheter 10 is further configured such that distendable section 110 thereof assumes a distended configuration suitable for displacing and repositioning an esophagus of a patient away from the patient's heart when first pulling member 136 is in an active or distended position within lumen 40 and catheter body 50 as first pulling member 136 is pulled by a user using, by way of non-limited example, catheter manipulation mechanism or handle 30. In addition, and in one embodiment, catheter 10 is configured such that a rotational or torsional force applied to proximal end 70 of catheter body 50 or handle 30 results in a rotation of proximal end 70 of catheter body 50 through a prescribed number of degrees, and may further be configured to result in such torsional force being transmitted efficiently through catheter body 50 and distendable section 110 such that distal end 90 of catheter body 50 also rotates substantially through the prescribed number of degrees when the such force is applied by a user or health care provider, distendable section and catheter body 50 rotating together substantially in single plane 20.

[0050] Note that depending on the particular configuration of distendable catheter 10 that is to be employed, catheter body 50 and catheter sidewalls 54 may be formed from any of a number of suitable biocompatible materials, including, but not limited to, silicone, silicone-based materials, medical-grade silicone, rubber silicone materials, latex-based materials, latex, rubber-based materials, rubber, rubber latex materials, urethane-based materials, polyurethane-containing materials, suitably flexible polyethylene-containing materials, polyethylene terephthalate (PET)-containing materials, polyisoprene-containing materials, polypropylene, fluoroplastic, polymers, elastomers, thermoplastic elastomers, and combinations and mixtures of the foregoing. Other materials that are biocompatible and suitably flexible, and that are otherwise safe for use inside the human body, are also contemplated.

[0051] First and second pulling members may be formed from any of a number suitable materials, including, but not limited to, wire, metal wire, alloy wire, stainless steel wire, stranded wires, braided wires, KEVLAR®, carbon fibers, wound, braided or stranded polymer fibers, and the like.

[0052] FIG. 2(c) shows a top perspective view of another embodiment of an esophageal displacement and repositioning catheter 10 in an active or distended position. As shown, catheter 10 comprises catheter body 50 having proximal end 70 and distal end 90, distendable section 110 of catheter body 50, and catheter manipulation handle 30. In one embodiment, catheter body 50 is further characterized in having length L3 associated with distendable section 110, and heights H1 and H2 associated with distendable section 110. Handle 30 comprises housing 32, pulling member tightening and loosening dial 34, and ratchet locking and unlocking button 36. In the embodiment shown in FIG. 2(c), distendable section 110 is in an active or distended position, where a user or health care provider has employed handle 30

and dial **34** to retract a first pulling member **136** (not shown in FIG. 2(c), but described in further detail below and in other Figures) disposed within catheter body **50** thereby to cause distendable section **110** to assume the distended configuration shown in FIG. 2(c). As shown, distendable section **110** comprises a leading edge **122** and a trailing edge **124**, a first height **H1**, and a second height **H2**. In comparison to the embodiment of FIGS. 2(a) and 2(b), it will be seen that distendable section **110** of the embodiment shown in FIG. 2(c) features a thickened or greater diameter distendable section **110**, where leading edge **122** is separated from trailing edge **124** by height **H2**.

[0053] It has been discovered that a thickened or greater diameter distendable section **110** can help pull at least portions of the trailing edge **202** of esophagus **200** (not shown in FIG. 2(c), but described below and shown in other Figures), towards distendable section **110** and therefore a further distance away from a patient's atrium or heart during an AF ablation procedure than can be achieved with the embodiment of catheter **10** shown in FIGS. 2(a) and 2(b).

[0054] Referring now to FIGS. 2(a) through 2(c), and in some embodiments, esophageal displacement catheter **10** is characterized by the following dimensions and/or specifications: (a) prescribed ranges of angles between sections of distendable section **110** range between about 40 degrees and about 90 degrees, between about 45 degrees and about 85 degrees, between about 50 degrees and about 80 degrees, between about 55 degrees and about 75 degrees, and/or between about 60 degrees and about 70 degrees; (b) first length **L1** between proximal and distal ends **70** and **90** of catheter body **50** ranges between about 200 mm and about 600 mm, between about 250 mm and about 550 mm; between about 300 mm and about 500 mm, and other lengths; (c) second length **L2** of distendable section **110** ranges between about 100 mm and about 300 mm, between about 125 mm and about 275 mm, between about 150 mm and about 250 mm, and other lengths; (d) third length **L3** of distendable section **110** ranges between about 80 mm and about 250 mm (where in some embodiments about 100 mm is a preferred third length **L3**); (e) first height **H1** of distendable section **110** ranges between about 40 mm and about 140 mm (where in some embodiments about 80 mm is a preferred first height **H1**), and second height **H2** of distendable section **110** ranges between about 20 mm and about 80 mm, between about 30 mm and about 70 mm, and/or between about 35 mm and about 65 mm. Other dimensions and specifications that will now become apparent to those skilled in the art after having read and understood the specification and drawings hereof are also contemplated.

[0055] FIG. 3(a) shows a cross-sectional view of one embodiment of esophageal displacement and repositioning catheter **10** positioned in esophagus **200** of a patient **5**, where catheter **10** is in a resting, non-distended or inactive position in patient **5**. Ablation tip **310** of AF ablation catheter **300** is positioned in one of the patient's atria. Trailing edge **202** of esophagus **200** is located in close proximity to, or distance **D1** away from, heart **220** and ablation tip **310**. Leading edge **204** of esophagus **200** is located further away from ablation tip **310** than distance **D1**. Catheter **10** can be configured such that catheter body **50** has length **L1** such that distal end **90** is configured to enter stomach **250**, or is configured not to enter stomach **250**. Indeed, catheter **10** can be configured to have lengths **L1**, **L2**, **L3**, **L4**, **H1** and **H2** selected such that

catheter **10** may be employed successfully in patients of different ages or who have differing esophageal, nose, mouth, and stomach dimensions and morphologies.

[0056] In one embodiment, catheter body **50** has a diameter of about 6 mm or less so that it can be inserted through a patient's nose, and further such that the patient need not undergo general anesthetic during the AF ablation procedure (as is typically done when an esophageal catheter is placed through the patient's mouth into esophagus **200**). Other diameters of catheter body **50** are also contemplated, such as by way of non-limiting example about 4 mm, about 5 mm, about 7 mm, about 8 mm, and so on.

[0057] In addition, esophageal displacement catheter **10** may comprise at least one radio-opaque, acoustically-opaque, or other type of marker disposed along catheter body **50** indicative of at least one of a first position of distal end **90** of catheter **10** in patient **5**'s esophagus **200** and a second position of distendable section **110** in the patient **5**'s esophagus **200**. In still other embodiments, esophageal displacement catheter **10** may comprise one or more temperature sensors, ultrasonic transducers, radio- or acoustically-opaque markers, and/or navigation sensors disposed in distendable section **110** or other portions of catheter **10**.

[0058] FIG. 3(b) shows a cross-sectional view of the esophageal displacement and repositioning catheter **10** of FIG. 3(a) positioned in esophagus **200** of a patient **5**, where catheter distendable section **110** of catheter **10** is in an active or distended position. As shown, trailing edge **202** of esophagus is now located a distance **D2** away from ablation tip **310**, esophagus **200** having been repositioned or displaced away from heart **220** by distendable section **110** of catheter **10**. In some embodiments, catheter **10** and distendable section **110** are configured such that trailing edge **202** of esophagus **200** is located at least about 20 mm away from heart or ablation tip **310**, at least about 25 mm away from heart or ablation tip **310**, at least about 30 mm away from heart or ablation tip **310**, at least about 35 mm away from heart or ablation tip **310**, at least about 40 mm away from heart or ablation tip **310**, at least about 45 mm away from heart or ablation tip **310**, and/or at least about 50 mm away from heart or ablation tip **310**. Catheter **10** may also be configured such that Distance **D2** achievable by catheter **10** is adjustable or selectable according to a number of pre-selected or predetermined heights **H1** and/or **H2** that catheter **10** is configured to provide.

[0059] Referring now to FIG. 4, there is shown a side view of one embodiment of a portion **111** of a distendable section **110** of an esophageal displacement and repositioning catheter, where a plurality of substantially rigid segments **112**, **114**, **116**, **118** and **120** are configured to be located in or on distendable section **110** of catheter **10**. As shown, and in one embodiment, segments **112**, **114**, **116**, **118** and **120** are serially connected to one another by flexible or rotatable joints **130a**, **130b**, **130c**, and **130d**, and each of segments **112**, **114**, **116**, **118** and **120** are rotatable through a prescribed range of angles (see, for example, FIGS. 6 and 7). Furthermore, in some embodiments segments **112**, **114**, **116**, **118** and **120** can be configured to rotate within substantially a same plane such that torque can be efficiently transmitted from a proximal end of distendable section **110** to a distal end of distendable section **110**. In some embodiments, segments **112**, **114**, **116**, **118** and **120** are formed, machined or milled from a metal or a metal alloy, but may also be formed using suitably stiff plastics, polymers or other mate-

rials. In some embodiments, swivelable and rotatable joints **130a**, **130b**, **130c**, and **130d** with pins are constrained to move substantially within the same plane. Note that distendable section **110** may comprise fewer or more than the five sections **112**, **114**, **116**, **118** and **120** shown in FIG. 4. For example, in some embodiments distendable section **110** comprises 3 such sections, 4 such sections, 6 such sections, 7 such sections, or any other suitable number of sections.

[0060] As shown in FIG. 4, and in one embodiment, distendable section comprises sections **112** and **120** having lengths **L6**, sections **114** and **118** having lengths **L5**, and central section **116** having length **L4**. As further explained and described below, lengths **L4**, **L5** and **L6** of sections **112-120**, in combination with bending angles  $\theta_1$ ,  $\theta_2$ ,  $\theta_3$ , and  $\theta_4$ , angle range limiters **132a-132d**, and constraining mechanisms **146** dimensions **146** (if employed) affect the particular dimensions **L1**, **L2**, **L3**, **H1**, and **H2** obtained in a given design of catheter **10**. By way of non-limiting example, in some embodiments, length **L4** ranges between about 80 mm and about 230 mm, or between about 50 mm and about 150 mm, length **L5** ranges between about 40 mm and about 140 mm, or between about 30 mm and about 100 mm, and length **L6** ranges between about 80 mm and about 230 mm, or between about 40 mm and about 150 mm. Other lengths of, and ranges of lengths for, **L4**, **L5** and **L6** are also contemplated.

[0061] Not shown in FIG. 4, but shown in FIGS. 5 and 6, are range limiters **132a**, **132b**, **132c**, and **132d** corresponding to each rotational joint **130a**, **130b**, **130c**, and **130d**, respectively, which are configured to prevent the various individual sections of distendable section **110** from over-rotating with respect to one another and potentially causing the collapse of distendable section **110** in an undesired manner. Range limiters **132a** through **132d** may be configured in a number of different ways, including with wires formed of single, braided or stranded individual wires, strands of synthetic fibers such as KEVLAR™, telescoping members, rigid materials, stretchable or elastic materials or bands, or any other suitable material or structure. Range limiters **132a**, **132b**, **132c** and **132d** are configured to prevent over-rotation of joints **130a**, **130b**, **130c** and **130d** when first pulling member **136** is retracted in catheter **10** (or when second pulling member **138** is retracted in catheter **10**, more about which is said below).

[0062] FIG. 5 shows a side cross-sectional view of one embodiment of distendable section **110** of esophageal displacement and repositioning catheter **10**. Note that FIG. 5 shows various details of distendable section **110** not shown in the preceding Figures. Shown in FIG. 5 are elastic, flexible and/or stretchable member, sheath, covering, or outer layer **144**, range limiters **132a**, **132b**, **132c**, and **132d**, ferrules, stand-offs or constraining mechanisms **146** through which first pulling member **136** slides or fits, first pulling member anchor **134**, and substantially rigid sections **112**, **114**, **116**, **118** and **120** disposed in a distended configuration having section bending angles  $\theta_1$ ,  $\theta_2$ ,  $\theta_3$ , and  $\theta_4$  disposed therebetween. Note that in some embodiments bending angles  $\theta_1$ ,  $\theta_2$ ,  $\theta_3$ , and  $\theta_4$  need not be the same, or that pairs of bending angles  $\theta_1/\theta_4$  and/or  $\theta_2/\theta_3$  need not be the same. Other configurations and combinations of bending angles  $\theta_1$ ,  $\theta_2$ ,  $\theta_3$ , and  $\theta_4$  are also contemplated. In the illustrated embodiments, the bending angles may be limited by range limiters **132a**, **132b**, **132c** and **132d**, respectively. According to some embodiments, any one of angles  $\theta_1$ ,  $\theta_2$ ,  $\theta_3$ , and  $\theta_4$

can range between about 90 degrees and about 160 degrees, between about 100 degrees and about 140 degrees, between about 105 degrees and about 135 degrees, and/or between about 110 degrees and about 130 degrees. Other angles and ranges of angles are also contemplated.

[0063] As shown In the embodiment of FIG. 5, distendable section **110** comprises a plurality of openings, slits, and/or recesses **150a**, **150b**, **150c**, and **150d** that are disposed or formed in the sidewalls **54** of catheter body **50** at or near the locations of joints **130a**, **130b**, **130c**, and **130d**, respectively, such that portions of first pulling member **136** can extend through such openings, slits or recesses and become located outside lumen **40** and catheter body **50** when first pulling member **136** is placed in the active or retracted position. Flexible member, sheath or covering **144** is configured to cover the openings, slits or recesses and the portions of first pulling member **136** extending outside lumen **40**, and is further configured to become deformed and distended by such pulling member portions that are located outside catheter body **50** and lumen **40** when first pulling member **136** is in an active or retracted position. Ferrules or other suitable constraining mechanisms **146** hold and constrain first pulling member **136** while permitting slidable movement therethrough at suitable locations within distendable section **110** such that the amount or degree by which first pulling member **136** can extend outside catheter body **50** and lumen **40** is appropriately limited to correspond to the sizes or extent of openings **150a**, **150b**, **150c** and **150d**.

[0064] In one embodiment, outer layer **144** is configured to protect esophagus **200** from catheter **50** and pulling member **136**, by “sucking” pulling member **136** back into lumen **40** of catheter **50** (or towards joints **130** or supports/range limiters **132**). Outer layer **144** can also be configured to insulate or protect a patient’s esophagus **200** or other portions of the patient’s body from any metal, metal alloy or other materials incorporated into or forming a portion of catheter **50**. In some embodiments, member, sheath, covering or outer layer **144** is formed of silicone or any other suitable flexible, elastic, and/or distendable, retractable and/or stretchable biocompatible material appropriate for use inside a patient’s body, more about which is said below.

[0065] Further shown in FIG. 5 are temperature sensors **140**, which according to one embodiment are incorporated into or attached to catheter **10**, and which may also be incorporated into or attached to at least portions of distendable section **110** and member, sheath, covering, or outer layer **144** such that temperatures in the vicinity of distendable section **110** and/or other sections of catheter body **50** may be monitored during an AF ablation procedure. Such temperature sensors **140** may molded into covering, sheath or outer layer **144**, or may be provided in any other suitable portion of catheter body **50**; corresponding electrical conductors can be provided in catheter **10** to transmit temperature signals to handle **30** from sensors **140**.

[0066] Alternatively, and as described in further detail below, temperature or others types of sensors (e.g., HIFU or high-intensity focused ultrasound sensors, navigation sensors, acoustic sensors, ultrasound sensors, radio-frequency coils or sensors, electrodes, off-the-shelf sensors or markers manufactured by third parties) may also be attached to the exterior or interior of catheter body **50** by clips, ferrules, bands or the like. Thus, temperature or other navigation or acoustic sensors, electrodes, transmitters or receivers may be provided external or internal to catheter body along and/or

on the outer surface thereof, internal thereto, or in a coating or sheath disposed over catheter 50.

[0067] In those embodiments where temperature sensors 140 are employed, and for purposes of providing the most accurate temperature readings unaffected or substantially unaffected by the thermal properties of the materials from which catheter 50 or coatings or sheaths disposed thereover are formed, temperature sensors 140 may be disposed along catheter 50 such that they are positioned near or in close proximity to trailing edge 202 of esophagus 200, and therefore on an outside surface of catheter 50, when catheter 50 is employed to displace esophagus 200 away from ablation site 310. Temperature sensor signals may be transmitted wirelessly from catheter 50 to handle 30 or any other desired reception site (such as an external temperature signal monitoring and amplification device). Similarly, navigation and radio-opaque markers may be disposed along or in catheter body 50 and/or distendable section 110 to permit enhanced imaging of catheter 10 after it has been disposed within a patient 5 by fluoroscopic, computerized tomography (CT) scanning, or any other suitable imaging method.

[0068] FIG. 6 shows a side cross-sectional view of another embodiment of distendable section 110 of esophageal displacement and repositioning catheter 10, where second pulling member 138 is further included in catheter 10 and distendable section 110. As shown, second pulling member 138 is configured to be retracted after distendable section 110 has been deployed into a distended configuration by retracting first pulling member 136. Second pulling member 138 then causes elastic or distendable outer sheath or covering 144 to be drawn downwardly from section 116 in the direction of the trailing edge 204 of esophagus 200 (not shown in FIG. 6) such that trailing edge 124 of distendable section 110 located below section 116 may be positioned in closer proximity to trailing edge 204 of esophagus 200. Such positioning of trailing edge 124 of catheter 10 permits more accurate measurements of temperatures in the vicinity of the trailing edge 204 of esophagus 200 (when temperature sensors are provided in or near trailing edge 124, which are not shown in FIG. 6), and also permits at least portions of the trailing edge 204 of esophagus 200 to be drawn more closely to distendable section 110 when deployed inside the patient's esophagus, thereby reducing the risk of burn or injury to the esophagus during an AF ablation procedure.

[0069] In FIG. 6, distendable section 110 comprises a plurality of openings, slits, and/or recesses 150a, 150b, 150c, and 150d that are disposed or formed in the sidewalls 54 of catheter body 50 at or near the locations of joints 130a, 130b, 130c, and 130d, respectively, such that portions of first pulling member 136 and second pulling member 138 can extend through such openings, slits or recesses and become located outside lumen 40 and catheter body 50 when first pulling member 136 is placed in the active or retracted position, and when second pulling member is deployed into an active or retracted position. Flexible member, sheath or covering 144 is configured to cover the openings, slits or recesses 150a, 150b, 150c, and 150d, and the portions of first pulling member 136 extending outside lumen 40, and is further configured to become deformed and distended by such portions of first pulling member 136 that have become located outside catheter body 50 and lumen 40 when first pulling member 136 is in the active or retracted position. Ferrules or other suitable constraining mechanisms 146 hold and constrain first pulling member 136 and second pulling

member 138 at suitable locations within distendable section 110 such that the amount or degree by which first pulling member 136 and second pulling member 138 can extend outside catheter body 50 and lumen 40 is appropriately limited to correspond to the sizes of openings 150a, 150b, 150c and 150d.

[0070] Continuing to refer to FIGS. 5 and 6, openings, recesses or slits 150a, 150b, 150c and 150d may possess different lengths and geometries along distendable section 110 and catheter body 50 according to the distention geometry of distendable section 110 that is desired to be achieved, as may the locations and types of constraining mechanisms 146 that are to be employed. In one embodiment, first pulling member 136 (and second pulling member 138, when employed), openings 150a through 150d, and constraining mechanisms 146 (if such mechanisms are utilized, which in some embodiments are not required as separate structural elements; see, e.g., FIGS. 7(a) and 8(a)) are together configured to permit a pulling member to be deployed outside opposing top and bottom surfaces of catheter body 50 and distendable section 110, such as the top and bottom surfaces of catheter body 50 shown in FIGS. 5 and 6.

[0071] The combination of substantially rigid sections 112 through 120, interconnecting joints 130a through 130d, openings 150a through 150d, range limiters 132a through 132d (if employed as separate structural elements), pulling members 136 and/or 138, and distendable cover or sheath 144 together result in a distendable section 110 that can be controllably and safely deployed to move a patient's esophagus 200 a safe distance D2 away from the patient's heart 220.

[0072] The respective specific lengths of sections 112-120 and openings 150a-150d, and the specific locations of constraining mechanisms 146 (if employed, as noted above) can all be varied and customized so that distendable section 110 and dimensions corresponding H1, H2, L3, L4 are capable of assuming an appropriate distended configuration that is suitable for a given type of esophageal displacement procedure, for a given patient's needs, and/or for a given patient's individual anatomical geometry. Thus, for an infant or child a small and compact distendable section 110 with certain appropriate dimensions H1, H2, L3, L4 may be employed, while for a large tall male patient a relatively large distendable section 110 and certain other appropriate dimensions may be employed. The length and amount of distension of the esophagus provided by distendable section 110 can also be adjusted by selecting dimensions H1, H2, L3, and/or L4 to provide the desired or optimal length and amount of distention of the esophagus for a given patient, class or type of patient, and/or type of medical or surgical procedure or treatment that is to be carried out on a patient and/or class or type of patient.

[0073] Referring now to FIGS. 5 and 6 as two reference points, in other embodiments distendable section 110 comprises a segmented catheter body 50, where individual segments of catheter body 50 are disposed individually over corresponding jointed portions of sections 112, 114, 116, 118 and 120, and where such individual segments of catheter body 50 are separated from one another by intervening portions between them having no or attenuated portions of a catheter body 50 disposed thereover, but where, for example, outer layer 144 is disposed between such individual segments of catheter body 50. In such embodiments, no openings, recesses, slots or slits are necessarily required

through which pulling members **136** and/or **138** can extend, as no intervening portions of catheter body **50** are disposed over the portions of pull wires **136** and/or **138** which are configured to extend outwardly away from sections **112**, **114**, **116**, **118** and/or **120** when distendable section **110** is in an active or deployed configuration.

[0074] In some embodiments, portions of substantially rigid sections **112**, **114**, **116**, **118** and **120**, and especially those portions of substantially rigid sections **112**, **114**, **116**, **118** and **120** located at or near joints **130a-130d**, are configured to be rounded and smooth so that the portions of at least one outer layer **144** disposed near joints **130a-130d** are not ripped, torn or damaged as outer layer **144** is stretched over joints **130a-130d** when distendable section **110** is placed in a deployed or active configuration.

[0075] After having read and understood the specification and drawings hereof, those skilled in the art will now understand that numerous permutations, adaptations, modifications, and combinations of the various structural elements disclosed and described herein are possible that can result in a distendable section **110** comprising one or more pull wires or pull members that are configured to extend outwardly away from any one or more of sections **112**, **114**, **116**, **118** and **120**, and thereby permit distendable section **110** to assume a distended or active deployed configuration, without departing from the scope and spirit of the inventions shown herein.

[0076] FIG. 7(a) shows a top perspective view of yet another embodiment of a distendable section **110** of an esophageal displacement and repositioning catheter **10**. In FIG. 7(a), and for purposes of easing illustration and description, outer elastic, distendable, stretchable and/or flexible member, layer, sheath or covering **144** is not shown (but is shown in FIGS. 7(b)). In addition, and again for purposes of easing illustration and description, range limiters **130a**, **130b**, **130c** and **130d** are not shown in FIG. 7(a) (but are shown in FIG. 8(c)). In FIG. 7(a), distendable section **110** comprises a series of sections **112**, **114**, **116**, **118** and **120** that are joined by flexible joints **130a**, **130b**, **130c** and **130d**. In one embodiment, sections **112**, **114**, **116**, **118** and **120**, and flexible joints **130a**, **130b**, **130c** and **130d**, are all formed of thin-walled stainless steel or any other suitable metal, metal alloy, plastic or polymer. Flexible joints **130a** through **130d** can be formed by suitably slitting or cutting distendable section **110** at appropriate locations **131** corresponding to the locations of flexible joints **130a**, **130b**, **130c** and **130d**, thereby to form such bendable joints. Joints **130a**, **130b**, **130c** and **130d** each also comprises a plurality of openings, slits or recesses **150a**, **150b**, **150c** and **150d** cut or formed into distendable section **110**, where such openings, slits or recesses are disposed at suitable locations along distendable section **110**.

[0077] Note that in addition to first and/or second pulling members **136** and/or **138** extending all the way through continuous openings **150a**, **150b**, **150c** and **150d** and outwardly away from catheter body **50** near the locations of joints **130a**, **130b**, **130c** and **130d** as shown in FIG. 7(a), in other embodiments openings **150a-150d** can also comprise discrete non-continuous first and second holes **150** corresponding to each joint **130**, where, for example, first and/or second pulling members **136** and/or **138** are routed from inside catheter **50** proximally through the first hole **150** located in a first position before a given joint, to outside the catheter body **50** over or near the joint **130**, and then back

inside catheter body **50** distally at the second hole **150** located in a second position after the given joint. Joint **130** can then be manipulated into a deployed position by retracting the pulling member **136** and/or **138**, where the pulling member extends away from and outside catheter body **50** between the first and second holes **150**. Similar configurations of holes **150** and pulling members **136/138** may be employed in other joints **130**. In such embodiments where pulling member **136** and/or **138** is routed outside catheter body **50** between holes **150**, outer layer or covering **144** is positioned over and covers those portions of pulling members **136** and/or **138** that are disposed outside catheter body **50** between holes **150**. Thus, it will now be seen that holes, recesses, openings, slits and recesses **150** can be configured in many different combinations, permutations and embodiments that permit a pulling member to extend outside catheter body **50**, and that permit the necessary amount of bending of joints **130** to be provided so as to permit a suitable amount of distention of a patient **5**'s esophagus **200**.

[0078] Slits or cuts **131** have suitable dimensions of width and length to permit a desired amount, degree and type of bending at joints **130a**, **130b**, **130c** and **130d**. Openings, recesses or slits **150a**, **150b**, **150c** and **150d** have dimensions appropriate to permit portions of first pulling member **136** to extend through such openings, slits or recesses and become located outside lumen **40** and catheter body **50** when first pulling member **136** is placed in the active or retracted position.

[0079] As shown in FIG. 7(b), flexible member, layer, sheath or covering **144** is configured to cover openings, slits or recesses **150a** through **150d** and the portions of first pulling member **136** that extend outside lumen **40**, and is further configured to become deformed and distended by such portions of first pulling member **136** that have become located outside catheter body **50** and lumen **40** when first pulling member **136** is in the active or retracted position. In the embodiment shown in FIG. 7(a), openings, recesses or slits **150a**, **150b**, **150c** and **150d** are configured to hold and constrain first pulling member **136** at suitable locations within distendable section **110** such that the amount or degree by which first pulling member **136** can extend outside catheter body **50** and lumen **40** is appropriately limited to correspond to the sizes of openings **150a**, **150b**, **150c** and **150d**.

[0080] In some embodiments of distendable section **110** shown in FIGS. 7(a) and 7(b), the thickness of sidewalls **54** of catheter **50** can range between about 0.2 mm and about 0.8 mm, and catheter **50** has an overall diameter ranging between about 4 mm and about 10 mm. Diameters of about 6 mm and less for catheter **50** are preferred, as they can more easily be inserted in esophagus **200** through patient's nose **240** (instead of through patient's mouth **242**).

[0081] Referring now to FIG. 8(a), first pulling member **136** is configured to cause distendable section **110** to assume a distended configuration when retracted through the action of a user or health care provider, and exits distendable section **110** through openings, recesses or slits at locations **150a**, **150b**, **150c**, and **150d** formed in the sidewalls of distendable section **110** opposite flexible joints **130a**, **130b**, **130c** and **130d**. Second pulling member **138** is configured to cause trailing edge **124** of outer sheath **144** to be pulled downwardly away from section **116** when retracted through the action of a user or health care provider in a fashion similar to that described above with respect to FIG. 6.

[0082] FIG. 8(b) shows distendable section 110 of FIG. 8(a) in a distended configuration, but with flexible, elastic or distendable member, sheath, covering or layer 144 disposed over the outer surfaces thereof. As shown in FIG. 8(b) and in other Figures, member, sheath, covering and/or layer 144 expands or stretches outwardly when distendable section 110 and pulling members 136 and 138 are together configured in an active or distended position, and retracts or pulls inwardly when distendable section 110 and pulling members 136 and 138 are together configured in an inactive or retracted position.

[0083] As noted above, in some embodiments member, sheath, covering or outer layer 144 is formed of silicone or any other suitable flexible, elastic, and/or distendable, retractable and/or stretchable biocompatible material appropriate for use inside a patient's body. Such materials for sheath or cover 144 include, but are not limited to, flexible, stretchable, distendable and retractable meshes, flexible, stretchable, distendable and retractable silicone-based materials, medical-grade silicone, rubber silicone materials, latex-based materials, latex, rubber-based materials, rubber, rubber latex materials, urethane-based materials, polyurethane-containing materials, suitably flexible polyethylene-containing materials, polyethylene terephthalate (PET)-containing materials, polyisoprene-containing materials, polypropylene, fluoroplastic, polymers, elastomers, and thermoplastic elastomers, and combinations and mixtures of the foregoing. Other materials that are biocompatible, flexible, stretchable, and retractable, and that are otherwise safe for use inside the human body, are also contemplated. In some embodiments, member, sheath, covering or outer layer 144 has a flexural modulus ranging between about 90 MPa and about 500 MPa.

[0084] FIG. 8(c) shows a cross-section of a portion of another embodiment of distendable section 110, where telescoping range limiters also act as joints 130a and 130b, and are attached to sidewalls 54 of catheter body 50. Other types of range limiters and joints are also contemplated, as will become apparent to one of skill in the art after having read and understood the present specification and drawings. As shown in FIG. 8(c), the edges of openings 150a and 150b guide and restrict the movement of wires 136 and 138 inside lumen 40. Temperature or other sensors or markers 140 may be disposed along trailing edge 124, for example to measure esophageal temperature during an AF ablation procedure or permit accurate imaging of the position of catheter 10 in patient 5.

[0085] FIGS. 9(a) through 9(e) illustrate certain features according to one embodiment of catheter 10. The various dimensions shown in FIGS. 9(a) through 9(e) are merely illustrative, and are not intended to be limiting. Those skilled in the art, upon having read and understood the present disclosure will understand and appreciate that other dimensions may be employed without departing from the scope and spirit of the inventions described and disclosed herein.

[0086] FIG. 9(a) shows a side view of another embodiment of catheter body 50, proximal end 70, distal end 90 and distendable section 110 of an esophageal displacement and repositioning catheter 10. For purposes of easing illustration, note that FIG. 9(a) does not show catheter handle 30 (which would be included in any complete catheter 10). Also note that for purposes of easing illustration slots 131 are not shown on all portions of catheter 50 in FIG. 9(a), and that none of slots 131 shown in FIGS. 10(a) through 10(e) extend

around the entire circumference of catheter body 50. Openings, recesses and/or slits or slots 150a through 150d are also not shown explicitly in FIGS. 9(a) through 9(e).

[0087] FIG. 9(b) shows a side view of catheter body 50 of esophageal displacement and repositioning catheter 10 shown in FIG. 9(a), including detail A thereof. As shown, slits or slots 131 are cut or formed along catheter body 50, thereby imparting bendability to catheter body 10, which permits catheter body 10 to be inserted through patient's nose 240 or mouth 242, and then into patient's esophagus 200. Detail A in FIG. 9(b) shows that slits or slots 131 are cut or otherwise formed in catheter body 50 such that each slit or slot does not circumscribe the entire circumference of catheter body 50, and instead is formed or cut only through a prescribed range of the circumference; a matrix 133 of uncut material thus extends around and between slots or slits 131. Such a slot or slit configuration imparts a substantial degree of torsional rigidity to catheter 10 such that a rotation of proximal end 70 of catheter body 50 through a given number of degrees results in the same or substantially the same number of degrees of rotation at distal end 90 of catheter body 50. In some embodiments, and depending on the number, spacing, depth, width and length of the various slits or slots disposed along catheter body 50, a 1:1 ratio or essentially a 1:1 turn ratio can be provided between the proximal and distal ends 70 and 90 of catheter 50 as proximal end 70 of catheter 10 is rotated by a user in the patient's esophagus such that a health care provider can place distendable section 110 in an optimal position with respect to ablation site 310 (e.g., such that distendable section 110 bows or deflects outwardly and away from ablation site 310). Such positioning may be effected with the aid of fluoroscopy or other well-known medical imaging methods. According to some embodiments, the torsional rigidity of catheter 10 is provided by matrix 133 of solid and uncut or unslotted metal, metal alloy or similarly rigid material that extends between proximal and distal ends 70 and 90 of catheter body 10, where the matrix extends between and around slots or slits 131.

[0088] Detail A in FIG. 9(b) shows such a configuration of slots or slits, where merely by way of non-limiting illustrative example slots or slits 131 are spaced 1.02 mm apart in the longitudinal direction, and 1.25 mm apart in the axial direction, where slots or slits 131 are 0.11 mm wide, and matrix 133 extends and is disposed between such slots or slits 131. Those skilled in the art, upon having read and understood the present disclosure, will appreciate that numerous other configurations, dimensions, spacings and other characteristics of slots or slits 131 and matrix 133 may be employed to impart both bendability and torsional rigidity to catheter body 50. For example, slits or slots 131 may be spaced apart in the longitudinal direction from one another between about 0.5 mm and about 1.5 mm, may be spaced apart in the axial direction between about 0.75 mm and about 1.75 mm, and may be between about 0.05 mm and about 0.2 mm wide. Other spacings and widths are also contemplated.

[0089] FIG. 9(c) shows a side view of distendable section 110 of esophageal displacement and repositioning catheter 10 shown in FIG. 9(a). FIG. 9(d) shows an end view of distendable section 110 of esophageal displacement and repositioning catheter 10 shown in FIG. 9(c). Details B, C, D and E are shown enlarged in FIG. 9(e). The various

dimensions shown in FIGS. 10(a) through 10(e) are merely illustrative, and are intended to show only a few of many different embodiments.

[0090] The various dimensions of catheter body 50 and distendable section 110 shown in FIGS. 9(a) through 9(e) illustrate that according to some embodiments catheter body 50 has thin stainless steel walls approximately 0.76 mm thick (with an outer diameter of 4.57 mm, and an inner diameter of 3.81 mm—see FIG. 10(d)). Spacing in the axial direction between slots or slits 131 (which can be 0.51 mm, by way of example) in joints 130a, 130b, 130c and 130d is reduced relative to spacing in the axial direction between slots or slits 131 in other portions of distendable section 110 or catheter body 50 (which can be 0.64 mm, by way of example). Such variations in slot or slit spacing in the axial direction between adjacent slots or slits permits joints 130a, 130b, 130c and 130d to have increased bendability or flexibility relative to other portions of distendable section 110 and/or catheter body 50. This is required so that distendable section 110 can be deployed and distended with adequate curvature to move a patient's esophagus a safe distance away from ablation site 310.

[0091] The various embodiments of catheter 10 shown in FIGS. 9(a) through 9(e) share some characteristics of the embodiments of catheters 10 shown in FIGS. 7(a) through 8(c). For example, the embodiment shown in FIGS. 9(a) through 9(e) features slits or slots cut into or otherwise formed in appropriate portions of thin-walled distendable section 110, which form bendable joints 130a, 130b, 130c and 130d, and that are also configured to impart lesser flexibility or bendability to other portions of catheter body 50. Each such joint comprises one or slits cut through or into the sidewalls of distendable section 110, where the slits or slots are disposed at suitable locations along distendable section 110, and the slits or slots have suitable dimensions of depth, width and length to permit a desired amount, degree and type of bending at joints 130a, 130b, 130c and 130d. Moreover, and in some embodiments, openings, recesses, or slots 150a through 150d are configured to act in conjunction with slots or slits 131 as range limiters at joints 130a, 130b, 130c and 130d so that such joints in distendable section 110 cannot be extended, or are difficult to extend, beyond prescribed ranges of bends (e.g., 85 degrees as shown in FIG. 9(c)). In another embodiment, slots or slits 131 have spacings and widths that permit limited maximum ranges of bending at joints 130a, 130b, 130c and 130d (e.g., about 85 degrees, although other degrees of bending are contemplated, such as about 90 degrees, about 80 degrees, about 70 degrees, about 60 degrees, about 50 degrees, about 45 degrees, about 40 degrees, about 30 degrees, and about 20 degrees).

[0092] In some embodiments joints 130a, 130b, 130c and 130d and other portions of distendable section 110 and/or catheter 50, are formed of thin-walled stainless steel or any other suitable metal, metal alloy, plastic or polymer. Thus, and while the disclosure with respect to FIGS. 7(a), 8(a) and FIGS. 9(a) through 9(e) focuses on embodiments of catheter 10 where proximal end 50, catheter body 50, distendable section 110, and distal end 90 of catheter body 50 are formed of thin-walled medical grade stainless steel, it is to be understood that other suitable materials such as polymers and plastics may also be employed to form catheter body 50.

[0093] Referring now to FIGS. 2(a) through 9(e), and according to some embodiments, esophageal displacement

catheter 10 comprises catheter body 50 comprising at least first lumen 40, distal end 90, proximal end 70, and distendable section 110. First lumen 40 extends between at least portions of proximal and distal ends 70 and 90 of catheter body 50. Catheter body 50 is configured to assume a substantially straight configuration along a first longitudinal axis  $A_{L1}$ , and/or to assume a flexible or limp configuration at least along portions thereof, when catheter body 50 is in a relaxed or non-active configuration. Catheter manipulation mechanism or handle 30 is disposed at or near proximal end 70 of catheter body 50. At least first pulling member 136 is disposed at least partially within catheter 10 and lumen 40, and has a distal portion thereof attached to a portion of catheter body 50 (e.g., first pulling member anchor 134) located at or near distal end 90 of catheter body 50. In one embodiment, pulling member 136 is operably connected to catheter manipulation mechanism 30 such that a user (e.g., a health care provider or physician) can tighten and relax pulling member 136 using, by way of non-limiting example, a pulling member tightening and loosening mechanism 34 forming a portion of or attached to catheter manipulation mechanism 30.

[0094] In some embodiments, distendable section 110 comprises a plurality joints, e.g., joints 130a, 130b, 130c and 130d, and is configured to permit distendable section 110 to deflect away from first longitudinal axis  $A_{L1}$  and bend substantially within single plane 20 along plurality of joints 130 when pulling member 136 is pulled towards proximal end 70 of catheter body 50. Distendable section 110 and catheter body 50 may further be configured to rotate substantially within single plane 20 when proximal end 70 of catheter body 50 is rotated by a user. Catheter body 50 may be configured such that distendable section 110 is configured to assume a distended configuration suitable for displacing and repositioning esophagus 200 of patient 5 a suitable distance (e.g., at least 20 mm) away from patient's heart 220 when pulling member 136 is in an active or distended position within lumen 40 and catheter body 50 as pulling member 136 is tightened by the user manipulating catheter manipulation mechanism 30. Catheter 10 is configured such that a torsional and rotational force applied to proximal end 70 of catheter body 50 or to catheter manipulation mechanism 30 by the user results in a rotation of proximal end 70 of catheter body 50 through a prescribed angle determined by the user, which in turn results in the torsional force being transmitted efficiently through catheter body 50 and distendable section 110 such that distendable section 110 also rotates substantially through the same prescribed angle when the torsional and rotational force is applied.

[0095] In addition, the various embodiments of catheter 10 can feature one or more of the characteristics described below. Distendable section 110 may comprise a plurality of substantially rigid segments (e.g., segments 112, 114, 116, 118 and 120) located in or on distendable section 110. Such segments can be serially connected to one another by flexible joints 130, where each joint 130 is rotatable through a prescribed range of angles. Such segments and joints may be configured to rotate together substantially within single plane 20 when proximal end 70 of catheter body 50 or catheter manipulation mechanism 30 is rotated by a user. One or more of joints 130 may have a range limiter 132 associated therewith. A range limiter 132 may be configured such that joint 130 associated therewith can bend no more than between about 40 degrees and about 90 degrees. Range

limiters **132** may be formed a wire, a braided wire, a stranded wire, a synthetic fiber of high tensile strength, or any other suitable material. In one embodiment, plurality of joints **130** may comprise at least first, second, third, fourth, and fifth substantially rigid segments **112**, **114**, **116**, **118** and **120** located in or on the distendable section **110**.

[0096] In still other embodiments, distendable section **110** may comprise a plurality of slots or slits **131** formed or machined therein, slots or slits **131** being configured to permit distendable section **110** to deflect away from first longitudinal axis  $A_{L1}$  and bend substantially within single plane **20** along plurality of joints **130** when pulling member **136** is pulled towards proximal end **70** of catheter body **50**, where joints **130** comprise slots or slits **131**.

[0097] Distendable section **110** and catheter body **50** may be configured to rotate substantially within single plane **20** when proximal end **70** of catheter body **50** or catheter manipulation mechanism **30** is rotated by the user. The plurality of joints **130** may further comprise at least first, second, third and fourth joints **130a**, **130b**, **130c**, **130d**, each of the first, second, third and fourth joints **130a**, **130b**, **130c**, **130d** together being rotatable through the prescribed angle. At least some of slots or slits **131** may be configured to act as range limiters **132** in distendable section **110**. At least one of range limiters **132** may be configured such that the joint **130** associated therewith can bend no more than between about 40 degrees and about 90 degrees.

[0098] First pulling member **136** may comprise one or more of a wire, braided wires, and stranded wires. Catheter **10** may further comprise a second pulling member **138** configured to cause elastic and/or deformable sheath **144** disposed at least around an outer diameter of distendable section **110** to engage a trailing edge **202** of patient **5**'s esophagus **200** when a proximal end of the second pulling member is pulled through the action of the user (e.g., by the user operating catheter manipulation mechanism **30**).

[0099] Distendable section **110** may comprise a polymeric or any other suitable material. At least portions of catheter body **50** may comprise thin-walled metal tubing. Such metal tubing may comprise stainless steel or alloys thereof. In some embodiments, the outside diameter of the metal tubing may range between about 2 mm and about 10 mm.

[0100] One or more temperature sensors, ultrasonic transducers, navigation sensors, and/or radio opaque markers may be disposed in distendable section **110** or other portions of catheter body **50**. At least one mark may be disposed along catheter body **50** that is indicative of at least one of a first position of distal end **90** of catheter body **50** in patient **5**'s esophagus **200** and a second position of distendable section **110** in patient **5**'s esophagus **200**.

[0101] FIGS. **10(a)** through **10(f)** show yet another embodiment of distendable section **110** of catheter **10**, where balloons **160a**, **160b** and **160c** are attached to or form a portion of distendable section **110**. Balloons **160a**, **160b** and **160c** are configured to further push patient **5**'s esophagus **200** a suitable and safe distance **D2** away from the patient's heart **220** and the source of heat **310** used to ablate the patient's heart of pulmonary vein during an atrial ablation procedure.

[0102] In FIG. **10(a)**, distendable section **110** is shown in a distended or active position, but with balloons **160a**, **160b** and **160c** not in expanded or deployed positions. In FIGS.

**10(b)** and **10(c)**, balloons **160a**, **160b** and **160c** are shown in their inflated or fully deployed states. As illustrated in FIG. **10(c)**, balloons **160a**, **160b** and **160c** push the patient's esophagus **200** further away from heart **220** than do the embodiments of distendable section **110** shown in preceding Figures. As shown in FIG. **10(c)**, and according to some embodiments, balloons **160a**, **160b** and **160(c)** may be characterized by lengths **L7**, **L8** and **L9**, respectively.

[0103] Balloons **160a** through **160c** may be inflated using air or a suitable fluid that is injected through catheter body **50** and suitable lumen(s) and/or tube(s) contained within or external to catheter body **50**, where the air or fluid is injected into (and/or withdrawn from) the balloons under the control of a health care provider using control mechanism **50**. Such air or fluid carrying lumens or tubes may be disposed outside and along catheter body **50**, or may be internal to catheter body **50**. By way of non-limiting example, balloons **160a** through **160c** may be formed of suitably expandable materials such as silicone, rubber, latex, MYLAR®, nylon, PTA, PTFE, polyurethane polyimide, polyurethane, polyethylene, polyimide, polyetheretherketone, polyethylene terephthalate, polypropylene, and/or fluoroplastic. In some embodiments, balloons **160a** through **160c** possess a flexural modulus of between about 90 MPa and about 500 MPa.

[0104] As shown in FIGS. **10(d)** through **10(f)**, balloons **160a** through **160c** may have diameters **D1**, **D2** and **D3**, which in some embodiments can range between about 8 mm and about 40 mm, between about 10 mm and about 25 mm, and between about 12 mm and about 16 mm. Other diameters of balloons **160a** through **160c** are also contemplated. For purposes of providing simplified views, note that FIGS. **10(d)** through **10(f)** do not illustrate all elements of a working distendable section **110**, such as pulling members **136** and/or **138**, outer layer or covering **144**, and so on.

[0105] The number of balloons attached to or forming a portion of distendable section **110** can also vary, such as one balloon, two balloons, four balloons, and other numbers of balloons. Balloons **160** may be disposed on upper, lower or side portions of distendable section **110** and/or catheter body **50**. Balloons **160a** through **160c** must possess sufficient burst strength not to rupture or break when deployed inside a patient and inflated or enlarged, and should be configured to withstand, by way of non-limiting example, pressures ranging between about 0.2 atmospheres (2.9 psi) and 1.0 atmosphere (14.7 psi). Balloons **160a**, **160b** and **160c** may also be configured to assume spherical, cylindrical, conically tapering and other suitable shapes. Balloons **160a** through **160d** may also be positioned on catheter body **50** such that outer layer or covering **144** is positioned over or on top of such balloons; such embodiments can permit eased routing of air and/or fluid supply to balloons **160a** through **160d**.

[0106] Balloons **160a**, **160b** and **160c** may be formed by heating a tubular material within a mold, heat-sealing thin sheets to one another, or using a blow-molding process. In a blow-molding process, a thermoplastic material such as nylon, polyurethane, or polycarbonate is extruded or formed into a hollow, tube-like shape (parison) and is subsequently heated and pressurized, usually with air, inside a hollow mold having a shape to form the final outer dimensions of the balloon.

[0107] FIGS. **11(a)** and **11(b)** show side cross-sectional and end cross-sectional views of portions of catheter body **50** having sensor coupling mechanism or holder **56** attached

thereto. As shown, sensor **140**, which by way of example may be any suitable sensor described above (such as a temperature sensor, a navigation sensor, an acoustic sensor, or a HIFU sensor) attaches to catheter body **50** by sliding through and frictionally engaging recess **58** of sensor coupling mechanism **56** (which extends outwardly from catheter body **54**). Other means of coupling and attaching sensors to the outside of catheter **50** are contemplated, such as moldings, bands, recesses, clips, screws, tape, adhesive, clamps, and so on. Sensor coupling mechanism **56** can be configured to permit off-the-shelf embodiments of sensors to be readily and quickly attached to catheter **10**.

**[0108]** FIG. **12** shows one embodiment of a method **400** for using an esophageal displacement and repositioning catheter **10**. In FIG. **12**, catheter **10** is first positioned through patient **5**'s nose or mouth at step **401**. At step **403**, a suitable imaging method is preferably, although not necessarily, employed to determine the position of catheter **10** and distendable section **110** in esophagus **200** relative to heart **220**. If catheter **10** is determined to be in an appropriate position in patient **5**'s esophagus relative to heart **220**, at step **405** distension mechanism **110** and/or balloons **160** of catheter **10** are deployed to reposition esophagus **200** away from heart **220** and/or ablation tip **310**. At step **407**, a suitable imaging method is preferably once again employed to determine the position of catheter **10** and distendable section **110** in esophagus **200** relative to heart **220**. If necessary, catheter **10** is straightened at step **409** and repositioned in esophagus **200**. Temperature or other data can be acquired from catheter **10** in step **411** or in any of the other steps of method **400** (as described above).

**[0109]** Many variants, permutations and combinations of method **400** described above are contemplated, including methods where certain of the above-described steps are eliminated, steps practiced in an order different from that described above, or other steps are added.

**[0110]** In addition to the systems, devices, and components described above, it will now become clear to those skilled in the art that various methods associated therewith are also disclosed and contemplated, such as methods of manufacturing and modifying esophageal repositioning and displacement catheters.

**[0111]** Various aspects or elements of the different embodiments described herein may also be combined to implement esophageal repositioning and displacement techniques.

**[0112]** The foregoing outlines features of several embodiments so that those skilled in the art may better understand the detailed description set forth herein. Those skilled in the art will now understand that many different permutations, combinations and variations of esophageal repositioning and displacement catheters **10** fall within the scope of the various embodiments. Those skilled in the art should appreciate that they may readily use the present disclosure as a basis for designing or modifying other processes and structures for carrying out the same purposes and/or achieving the same advantages of the embodiments introduced herein. Those skilled in the art should also realize that such equivalent constructions do not depart from the spirit and scope of the present disclosure, and that they may make various changes, substitutions and alterations herein without departing from the spirit and scope of the present disclosure.

**[0113]** After having read and understood the present specification, those skilled in the art will now understand and

appreciate that the various embodiments described herein provide solutions to long-standing problems in the use of esophageal repositioning and displacement catheters.

1. An esophageal displacement catheter, comprising:

a catheter body having a longitudinal axis associated therewith, the catheter body comprising a distal end, a proximal end, at least one lumen, and a distendable section having sidewalls, the lumen extending between at least portions of the proximal and distal ends, the catheter body being configured to assume an at least partially flexible or limp configuration along at least portions of the longitudinal axis when the catheter body is in a relaxed or non-active configuration;

a catheter manipulation mechanism disposed at or near the proximal end of the catheter body;

at least a first pulling member disposed at least partially within the catheter and the lumen, the first pulling member comprising a distal portion operably connected to or near a distal end of the catheter body and a proximal portion operably connected to the catheter manipulation mechanism such that a user can tighten and relax the pulling member using the catheter manipulation mechanism, and

at least one elastic flexible deformable or distendable member, sheath, layer or covering disposed over at least portions of the distendable section;

wherein the distendable section comprises a plurality of substantially rigid sections interconnected by a plurality of joints disposed along the distendable section, the joints and substantially rigid segments being configured to permit the distendable section to deflect away from the longitudinal axis and assume a distended configuration when the first pulling member is pulled or retracted sufficiently far towards the proximal end of the catheter body using the catheter manipulation mechanism, the distendable section further being configured such that portions of the first pulling member extend sufficiently far away from the joints when the first pulling member is in a retracted position to permit the distendable section to assume a deployed and distended configuration, and the at least one flexible deformable or distendable member, sheath or covering is configured to be disposed over and cover the portions of the first pulling member extending away from the joints when the distendable section is the deployed and distended configuration, the catheter being configured to displace and reposition an esophagus of a patient at least 20 mm away from the patient's heart when the distendable section is in the deployed and distended configuration.

2. The esophageal displacement catheter of claim **1**, wherein the distendable section further comprises a plurality of openings, recesses, slots or slits disposed in the sidewalls of the catheter body at or near at least some of the joints such that the portions of the first pulling member extending away from the joints are disposed through the openings, recesses, slots or slits when the distendable section is in the deployed and distended configuration.

3. The esophageal displacement catheter of claim **1**, wherein distendable section comprises at least three, four or five substantially rigid sections.

4. The esophageal displacement catheter of claim **1**, wherein the distendable section is configured to form a compound bend substantially within a single plane along the

plurality of joints when the pulling member is pulled towards the proximal end of the catheter body.

5. The esophageal displacement catheter of claim 4, wherein the distendable section and the catheter body are further configured to rotate substantially within the single plane when the proximal end of the catheter body is rotated by a user.

6. The esophageal displacement catheter of claim 5, wherein the catheter is configured such that a torsional and rotational force applied to the proximal end of the catheter body or the catheter manipulation mechanism by the user results in the torsional force being transmitted to the distal end of the catheter.

7. The esophageal displacement catheter of claim 1, wherein each substantially rigid segment is rotatable through a prescribed range of angles.

8. The esophageal displacement catheter of claim 1, wherein at least one of the joints has a range limiter associated therewith.

9. The esophageal displacement catheter of claim 1, wherein a first length L1 between the proximal and distal ends of the catheter body ranges between about 200 mm and about 600 mm.

10. The esophageal displacement catheter of claim 1, wherein a second length L2 of the distendable section ranges between about 100 mm and about 300 mm.

11. The esophageal displacement catheter of claim 1, wherein a third length L3 of the distendable section ranges between about 80 mm and about 250 mm.

12. The esophageal displacement catheter of claim 1, wherein a first height H1 of the distendable section ranges between about 40 mm and about 140 mm.

13. The esophageal displacement catheter of claim 1, wherein a second height H2 of the distendable section ranges between about 20 mm and about 80 mm.

14. The esophageal displacement catheter of claim 1, further comprising a second pulling member configured to cause portions of the at least one elastic flexible deformable or distendable member, sheath, layer or covering to engage a trailing edge of the patient's esophagus when a proximal end of the second pulling member is retracted.

15. The esophageal displacement catheter of claim 1, wherein the at least one elastic flexible deformable or distendable member, sheath, layer or covering comprises one or more of a flexible, stretchable, distendable and retractable mesh, or a flexible, stretchable, distendable and retractable silicone-based material, a medical-grade silicone, a rubber silicone material, a latex-based material, latex, a rubber-based material, rubber, a rubber latex material, a urethane-based material, a polyurethane-containing material, a flexible polyethylene-containing material, a polyethylene terephthalate (PET)-containing material, a polyisoprene-containing material, polypropylene, fluoroplastic, a polymer, an elastomer, a thermoplastic elastomer, or a combination or mixture of the foregoing.

16. The esophageal displacement catheter of claim 1, wherein at least portions of the catheter body comprise thin-walled metal tubing.

17. The esophageal displacement catheter of claim 16, wherein the metal tubing comprises stainless steel or alloys thereof.

18. The esophageal displacement catheter of claim 1, wherein a diameter of the catheter body ranges between about 2 mm and about 10 mm.

19. The esophageal displacement catheter of claim 1, further comprising one or more temperature sensors disposed in the distendable section.

20. The esophageal displacement catheter of claim 1, further comprising one or more ultrasonic transducers disposed in the distendable section.

21. The esophageal displacement catheter of claim 1, further comprising one or more navigation sensors disposed in the distendable section.

22. The esophageal displacement catheter of claim 1, further comprising one or more radio opaque markers disposed in the distendable section.

23. The esophageal displacement catheter of claim 1, further comprising one or more balloons disposed in the distendable section, the balloons being configured to enlarge controllably a diameter of the distendable section.

24. A method of displacing a portion of an esophagus of a patient away from the patient's heart with an esophageal displacement catheter, the catheter comprising a catheter body having a longitudinal axis associated therewith, the catheter body comprising a distal end, a proximal end, at least one lumen, and a distendable section having sidewalls, the lumen extending between at least portions of the proximal and distal ends, the catheter body being configured to assume an at least partially flexible or limp configuration along at least portions of the longitudinal axis when the catheter body is in a relaxed or non-active configuration, a catheter manipulation mechanism disposed at or near the proximal end of the catheter body, at least a first pulling member disposed at least partially within the catheter and the lumen and comprising a distal portion operably connected to or near a distal end of the catheter body and a proximal portion operably connected to the catheter manipulation mechanism such that a user can tighten and relax the pulling member using the catheter manipulation mechanism, and at least one elastic flexible deformable or distendable member, sheath, layer or covering disposed over at least portions of the distendable section, the distendable section comprising a plurality of substantially rigid sections interconnected by a plurality of joints disposed along the distendable section, the joints and substantially rigid segments being configured to permit the distendable section to deflect away from the longitudinal axis and assume a distended configuration when the first pulling member is retracted or pulled sufficiently far towards the proximal end of the catheter body using the catheter manipulation mechanism, the distendable section further being configured such that portions of the first pulling member extend sufficiently far away from the joints when the first pulling member is in a retracted position to permit the distendable section to assume a deployed and distended configuration, and the at least one flexible deformable or distendable member, sheath or covering is configured to be disposed over and cover the portions of the first pulling member extending away from the joints when the distendable section is the deployed and distended configuration, the catheter being configured to displace and reposition an esophagus of a patient at least 20 mm away from the patient's heart when the distendable section is in the deployed and distended configuration, the method comprising:

inserting the distal end of the catheter body in the patient's nose or mouth;

inserting and positioning the distal end of the catheter into the patient's esophagus, and

causing the first puffing member to retract in the direction of the proximal end of the catheter body such that the distendable section is deployed, the distendable section assumes the distended configuration, and the distendable section positions the patient's esophagus at least 20 mm away from the patient's heart.

**25.** The esophageal displacement method of claim **24**, further comprising medically imaging the position of the catheter in the patient's esophagus.

**26.** The esophageal displacement method of claim **25**, further comprising re-positioning the catheter in the patient's esophagus based on the imaging results.

**27.** The esophageal displacement method of claim **24**, further comprising monitoring a temperature of a trailing edge of the patient's esophagus using one or more temperature sensors located in the distendable section of the catheter.

\* \* \* \* \*

专利名称(译)	用于在心房消融期间远离心脏移位和重新定位食道的系统，装置，部件和方法外科手术		
公开(公告)号	<a href="#">US20170252027A1</a>	公开(公告)日	2017-09-07
申请号	US15/603176	申请日	2017-05-23
[标]申请(专利权)人(译)	DNP生物医学有限公司		
申请(专利权)人(译)	DNP生物医学，LLC		
当前申请(专利权)人(译)	DNP生物医学，LLC		
[标]发明人	KASIC II JAMES F		
发明人	KASIC, II, JAMES F.		
IPC分类号	A61B17/00 A61B18/14 A61B5/00 A61B17/02		
CPC分类号	A61B17/00234 A61B17/0218 A61B18/14 A61B5/0071 A61B18/1492 A61B2090/3966 A61B2018/00351 A61B2018/00577 A61B2018/00791 A61B2018/00982 A61B2017/00323 A61B2017/00084 A61B2017/00309		
其他公开文献	US10265058		
外部链接	<a href="#">Espacenet</a> <a href="#">USPTO</a>		

摘要(译)

公开了用于在心房消融外科手术过程中将患者食道重新定位或移位离开患者心脏安全距离的系统，装置，部件和方法的各种实施例。公开了一种食道移位导管，其配置成将患者的食道重新定位在距患者心脏中的消融位置20mm或更远处。导管的可扩张部分构造使得当第一牵拉构件处于缩回位置时第一牵拉构件的部分远离位于可扩张部分中的接头延伸，以允许可扩张部分呈现展开和扩张构型。至少一个柔性可变形或可扩张构件，护套或覆盖物构造当可扩张部分是展开和扩张构型时设置在第一牵拉构件的远离接头延伸的部分上并覆盖第一牵引构件的部分。还可以将一个或多个球囊结合到导管中以可控制地扩大可扩张部分的直径。

