



US 20160278857A1

(19) **United States**

(12) **Patent Application Publication**
Panescu et al.

(10) **Pub. No.: US 2016/0278857 A1**

(43) **Pub. Date: Sep. 29, 2016**

(54) **SYSTEMS AND METHODS FOR HIGH-RESOLUTION MAPPING OF TISSUE**

Publication Classification

(71) Applicant: **ADVANCED CARDIAC THERAPEUTICS, INC.**, Santa Clara, CA (US)

(51) **Int. Cl.**
A61B 18/14 (2006.01)
A61B 5/00 (2006.01)
A61B 5/053 (2006.01)

(72) Inventors: **Dorin Panescu**, San Jose, CA (US);
Josef Vincent Koblish, Sunnyvale, CA (US); **Jessi E. Johnson**, Sunnyvale, CA (US)

(52) **U.S. Cl.**
CPC *A61B 18/1492* (2013.01); *A61B 5/0538* (2013.01); *A61B 5/6858* (2013.01); *A61B 2017/00026* (2013.01)

(21) Appl. No.: **15/179,891**

(22) Filed: **Jun. 10, 2016**

Related U.S. Application Data

(63) Continuation of application No. PCT/US2015/061353, filed on Nov. 18, 2015.

(60) Provisional application No. 62/159,898, filed on May 11, 2015, provisional application No. 62/081,710, filed on Nov. 19, 2014.

(57) **ABSTRACT**

According to some embodiments, methods and systems of enhancing a map of a targeted anatomical region comprise receiving mapping data from a plurality of mapping electrodes, receiving high-resolution mapping data from a high-resolution roving electrode configured to be moved to locations between the plurality of mapping electrodes, wherein the mapping system is configured to supplement, enhance or refine a map of the targeted anatomical region or to directly create a high-resolution three-dimensional map using the processor receiving the data obtained from the plurality of mapping electrodes and from the high-resolution roving electrode.

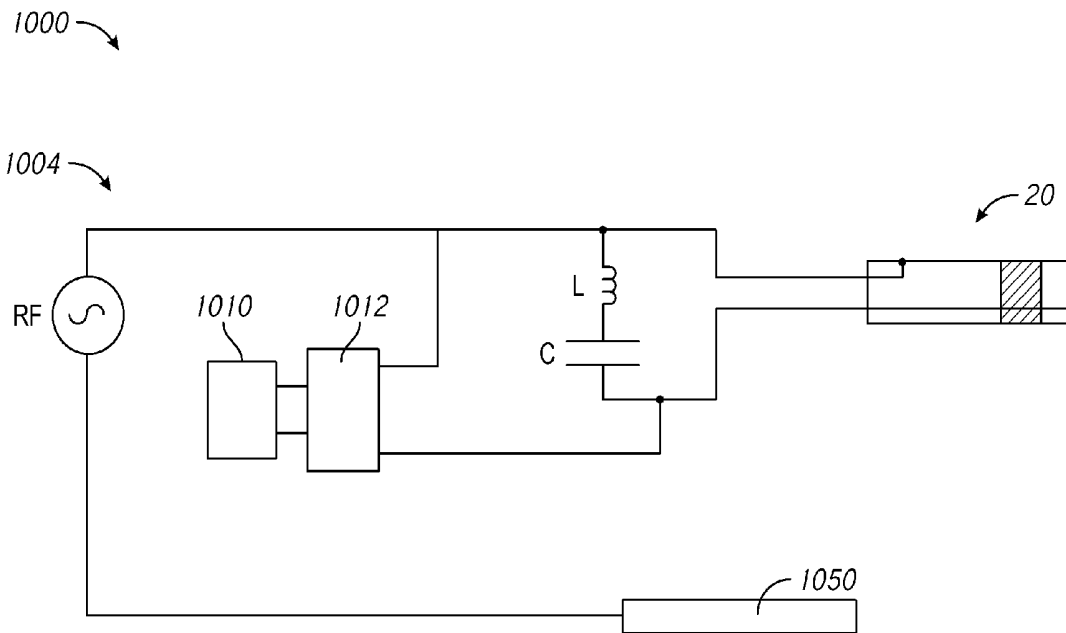

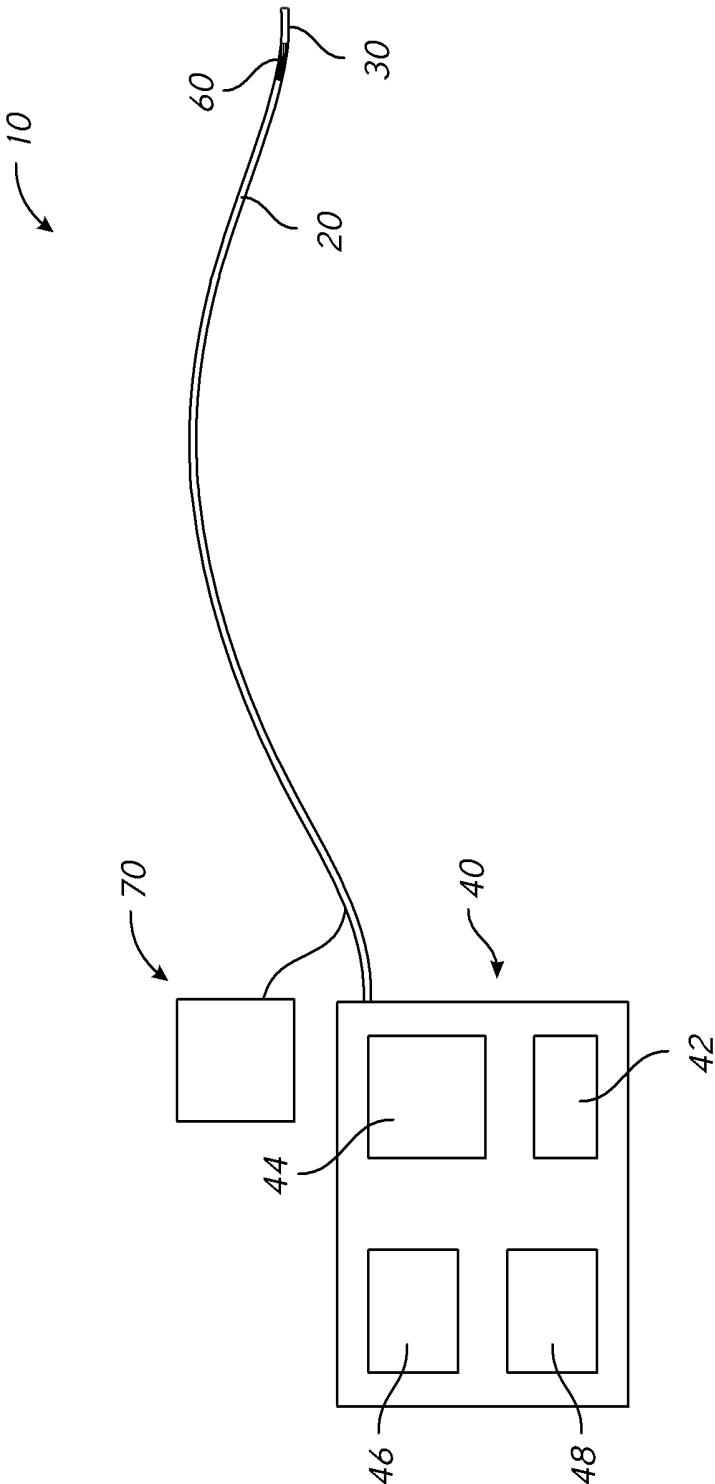

FIG. 1

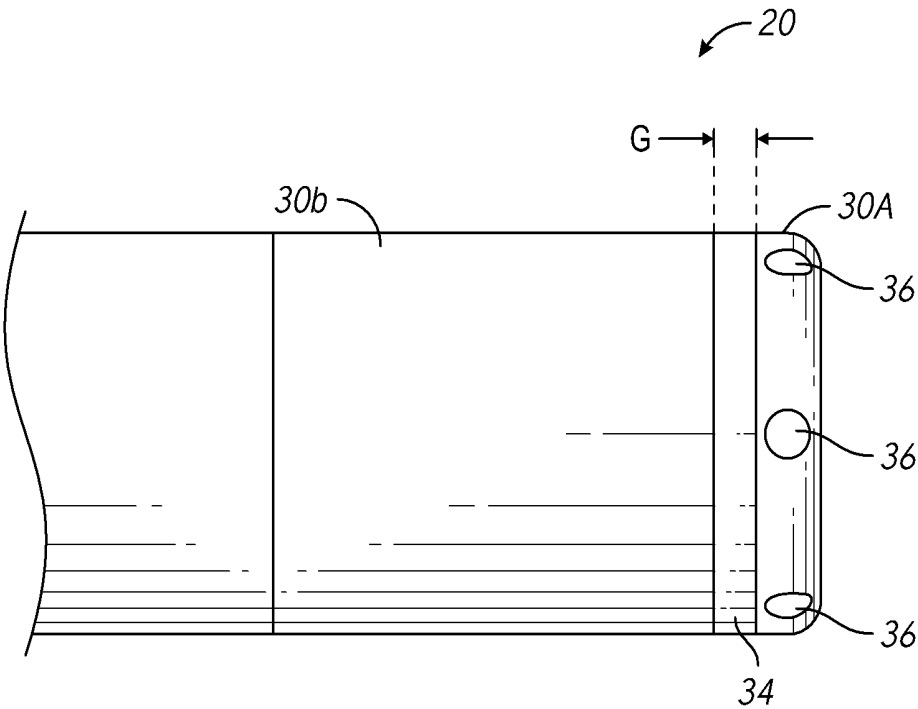

FIG. 2

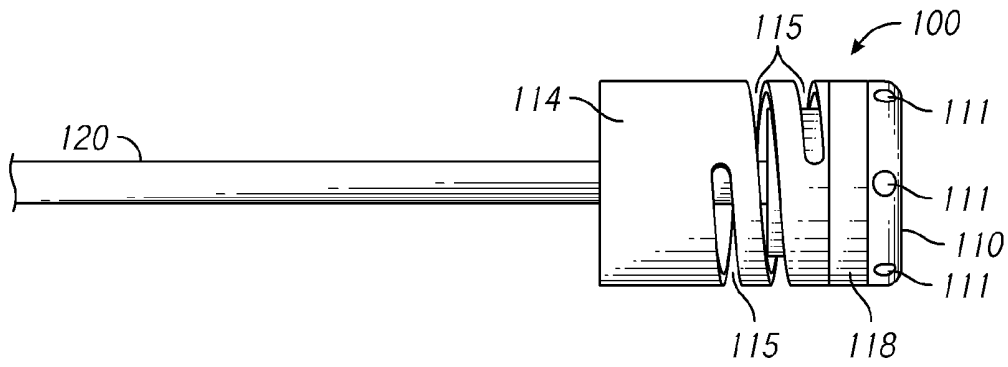

FIG. 3

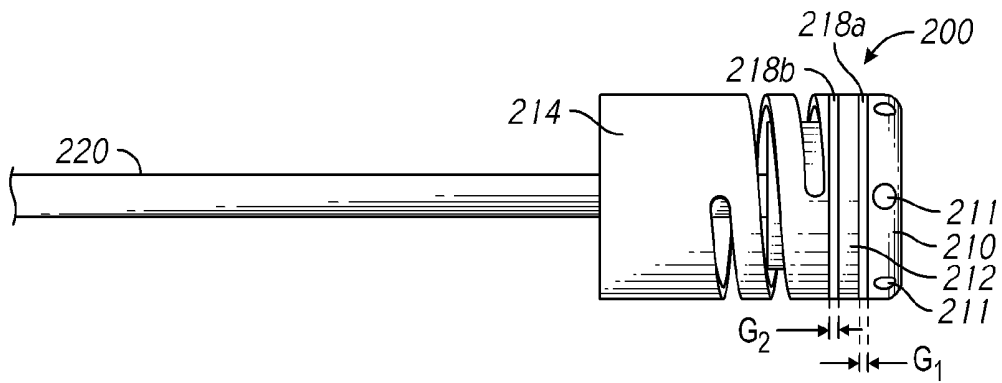

FIG. 4

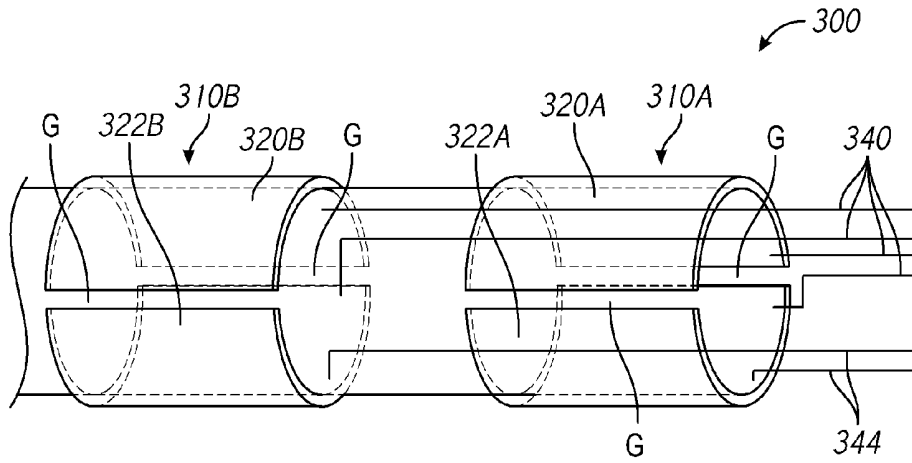

FIG. 5

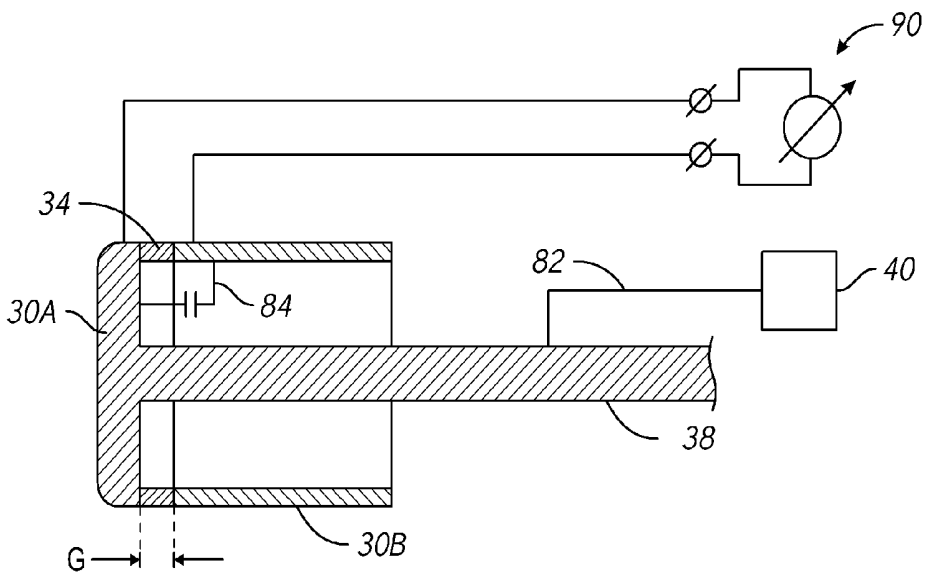

FIG. 6

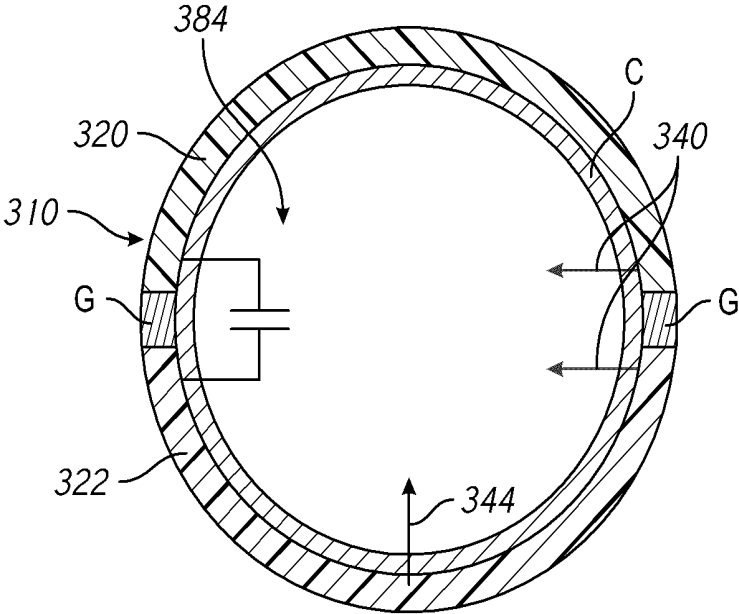

FIG. 7

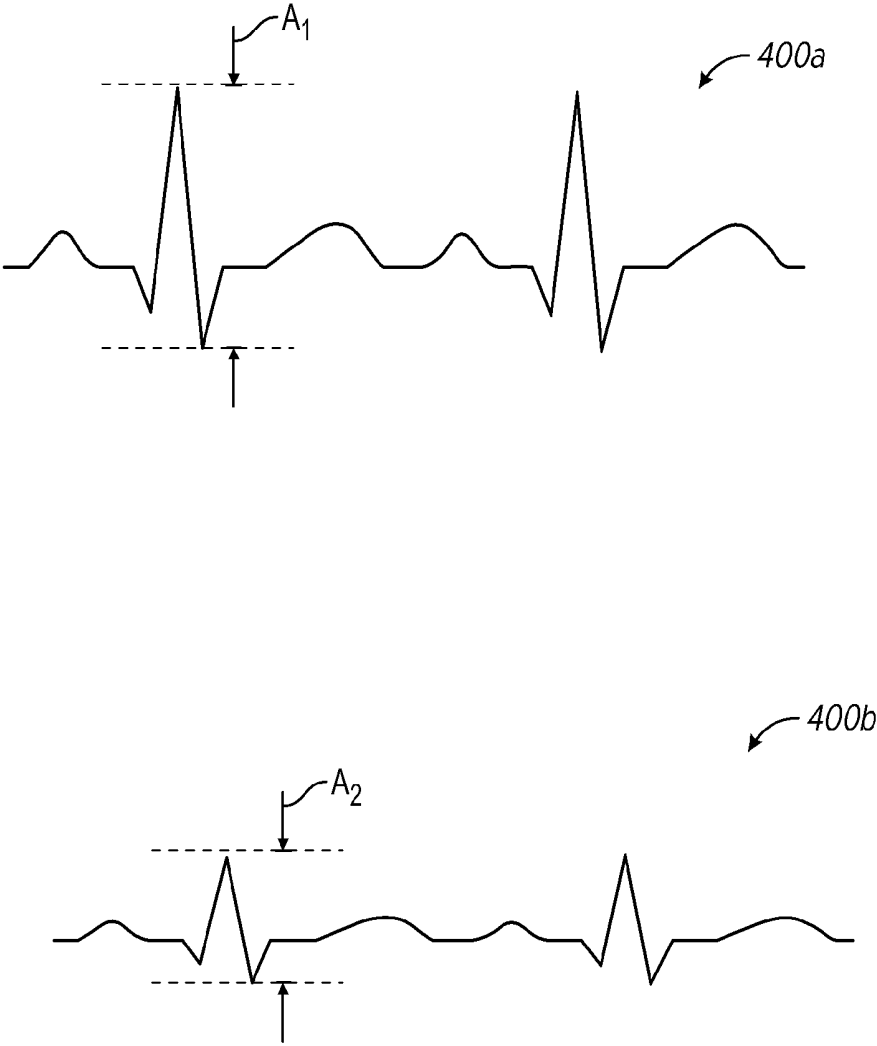

FIG. 8

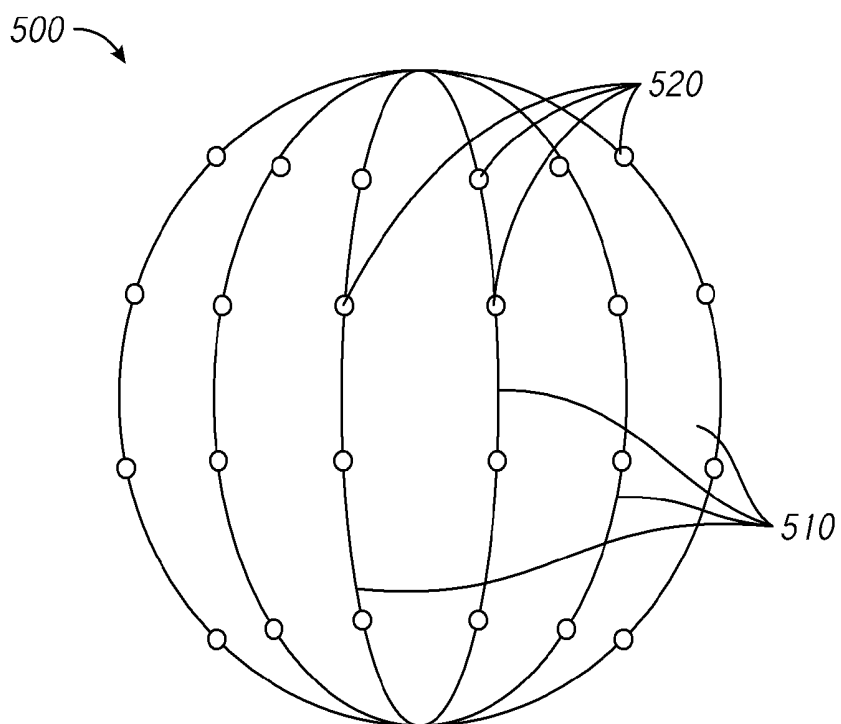

FIG. 9

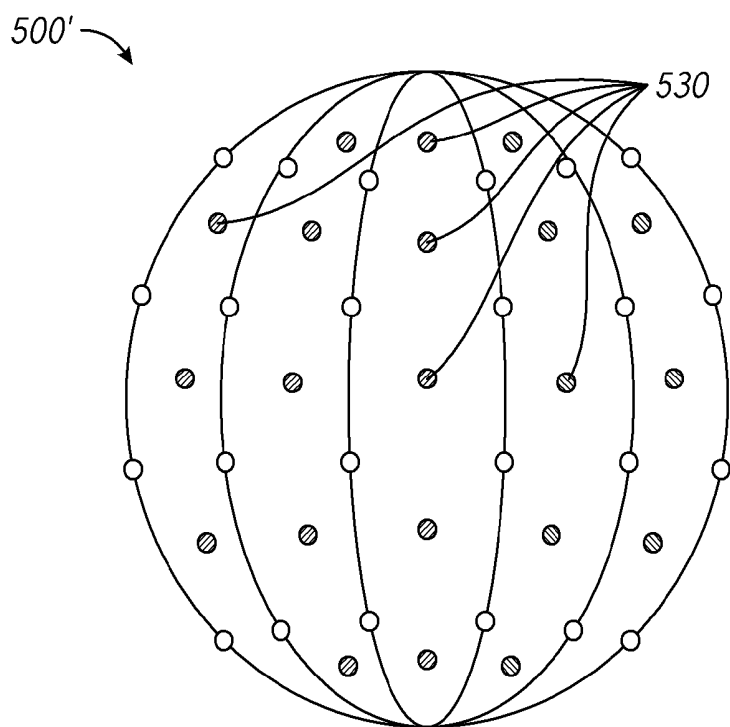

FIG. 10

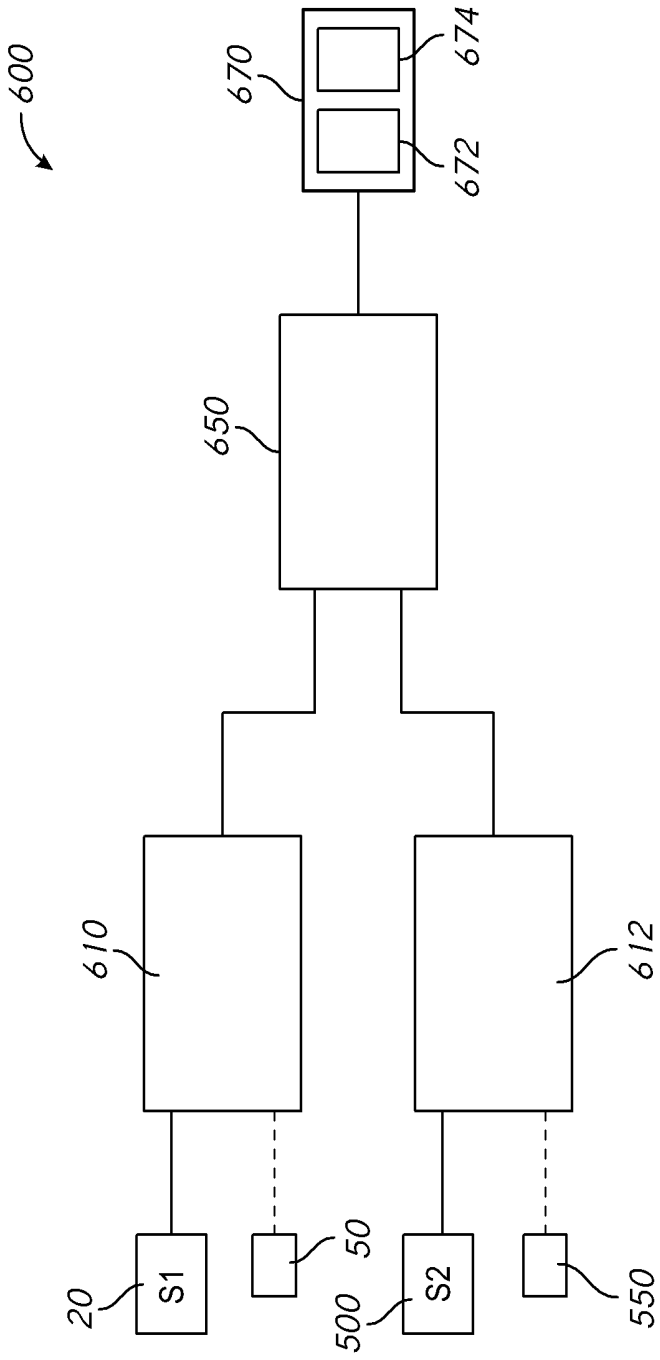

FIG. 11

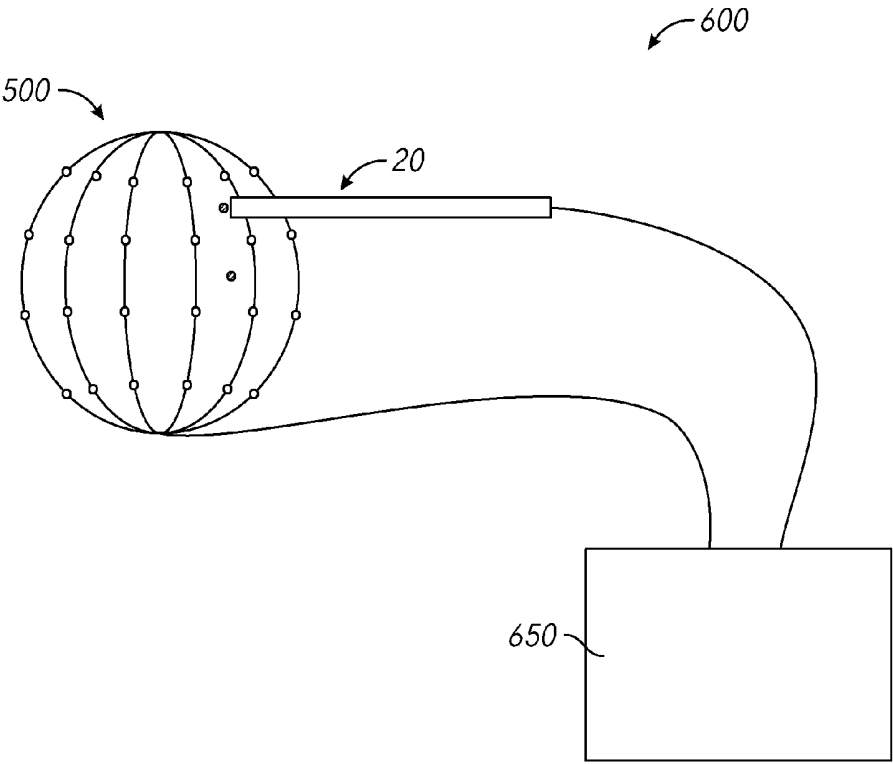

FIG. 12

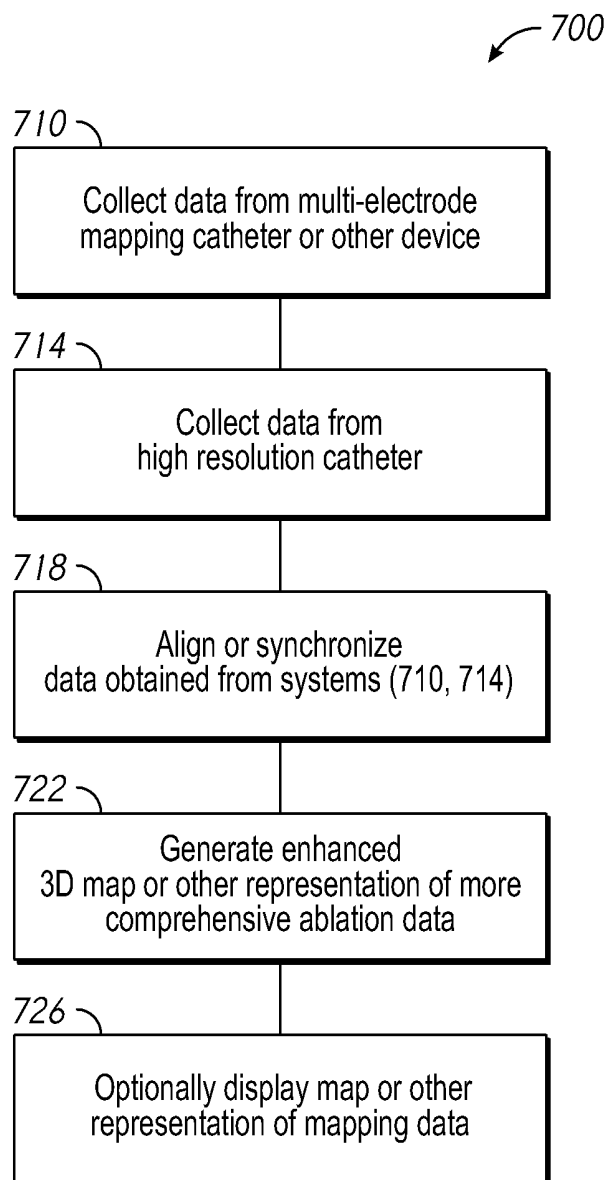

FIG. 13

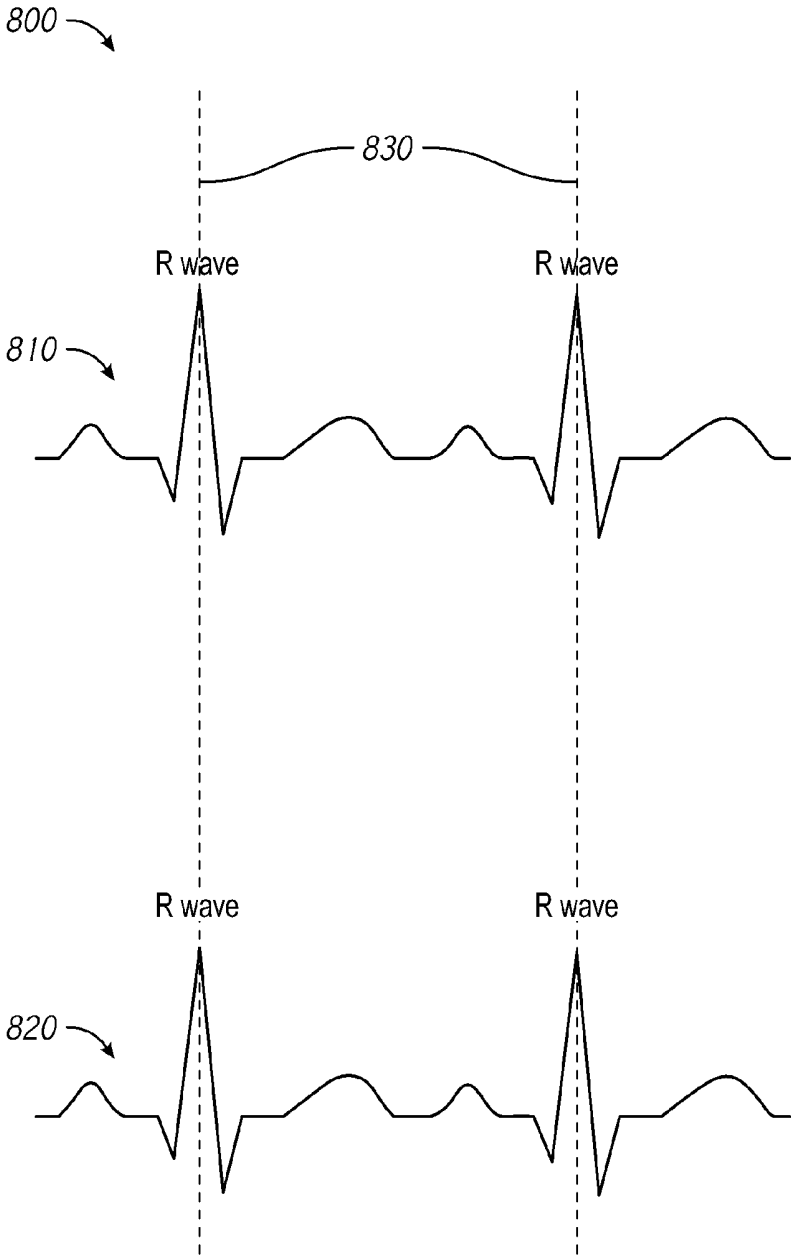

FIG. 14

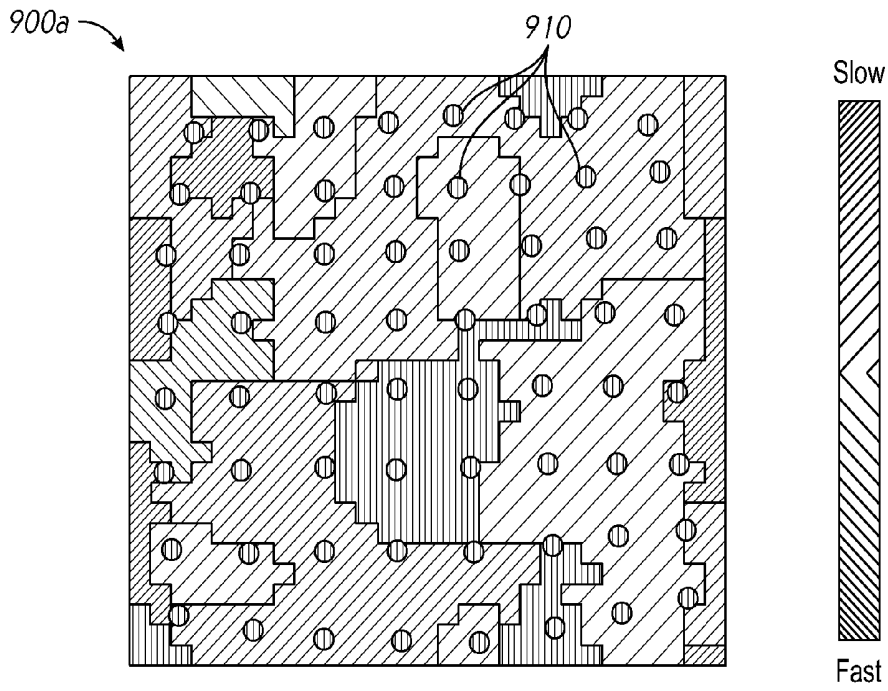

FIG. 15A

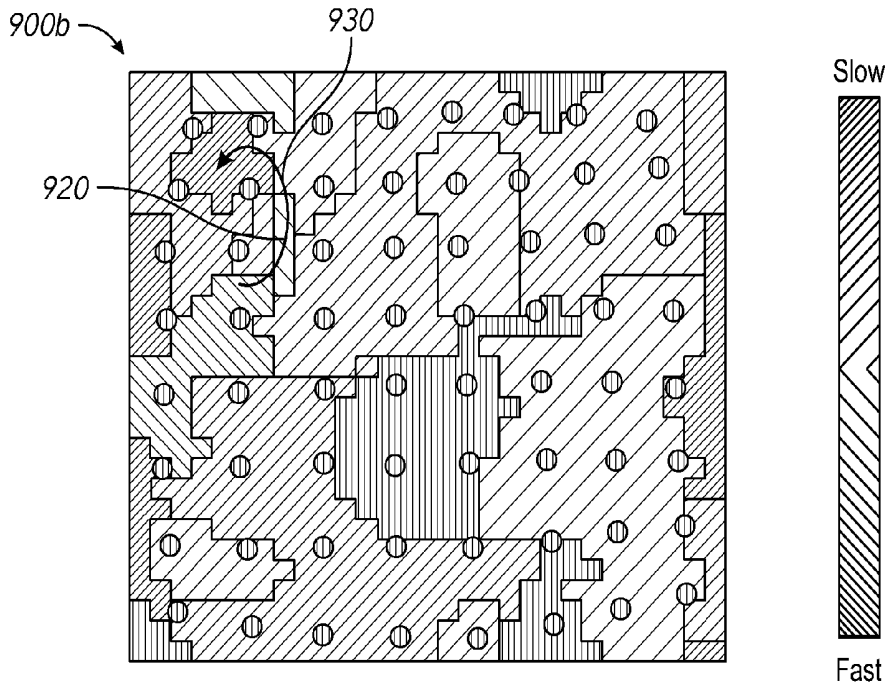

FIG. 15B

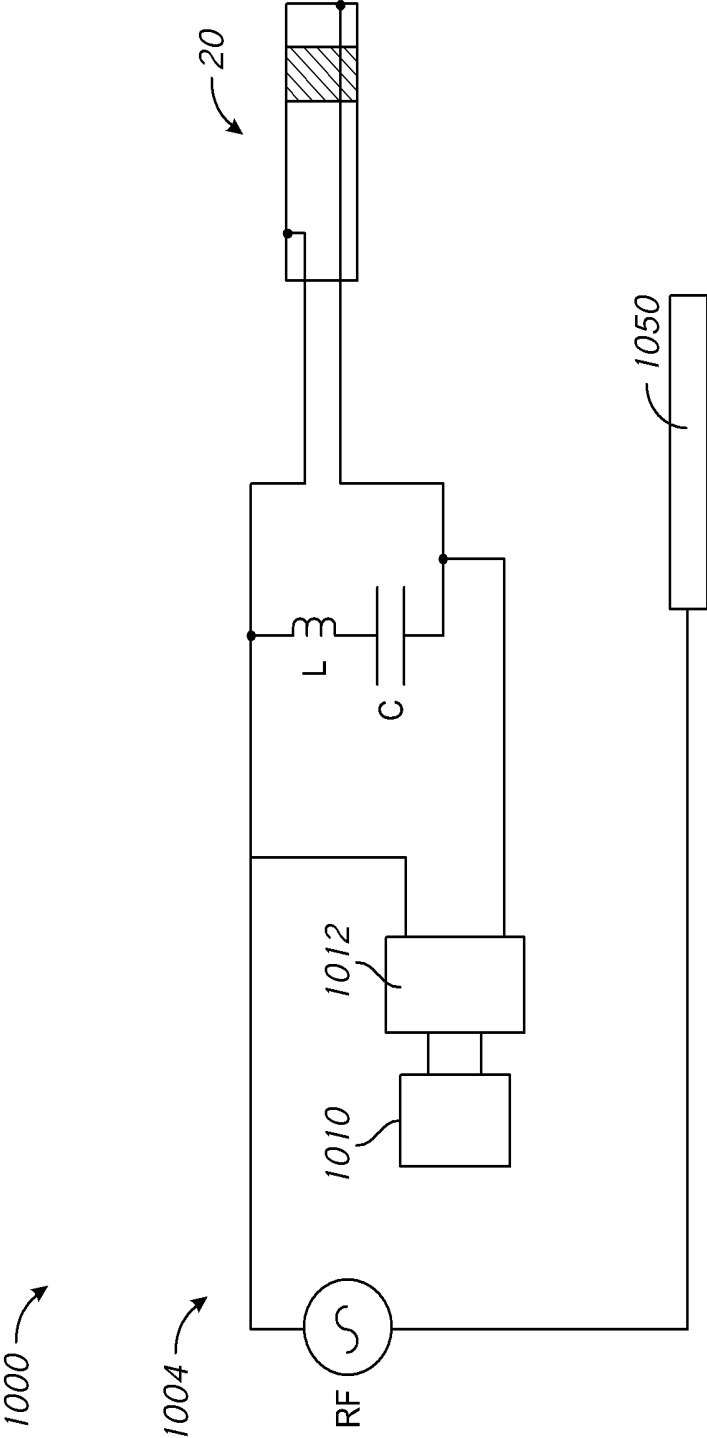

FIG. 16

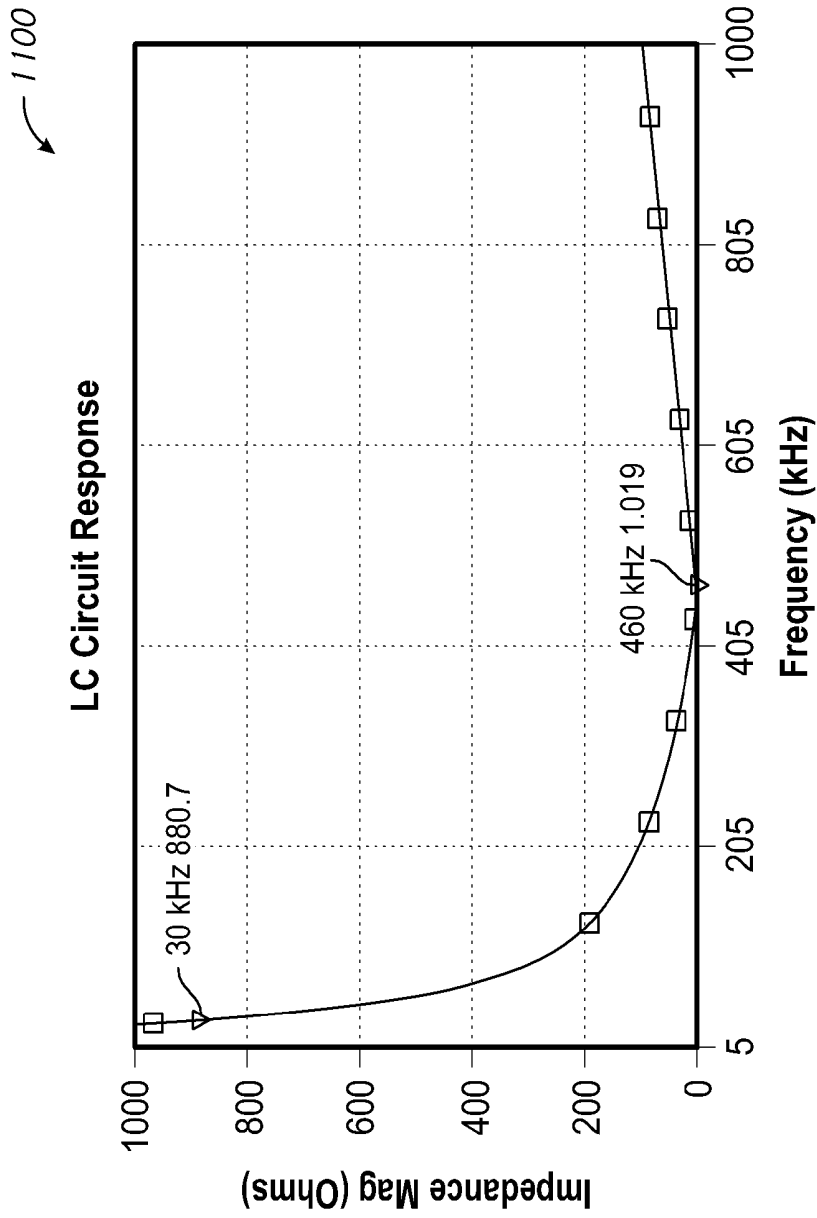

FIG. 17

SYSTEMS AND METHODS FOR HIGH-RESOLUTION MAPPING OF TISSUE

RELATED APPLICATIONS

[0001] This application is a continuation application of PCT/US2015/061353, filed Nov. 18, 2015, which claims priority to U.S. Provisional Application No. 62/081,710, filed Nov. 19, 2014, and U.S. Provisional Application No. 62/159,898, filed May 11, 2015, the entire contents of each of which are incorporated herein by reference in their entirety.

BACKGROUND

[0002] Tissue ablation may be used to treat a variety of clinical disorders. For example, tissue ablation may be used to treat cardiac arrhythmias by at least partially destroying (e.g., at least partially or completely ablating, interrupting, inhibiting, terminating conduction of, otherwise affecting, etc.) aberrant pathways that would otherwise conduct abnormal electrical signals to the heart muscle. Several ablation techniques have been developed, including cryoablation, microwave ablation, radio frequency (RF) ablation, and high frequency ultrasound ablation. For cardiac applications, such techniques are typically performed by a clinician who introduces a catheter having an ablative tip to the endocardium via the venous vasculature, positions the ablative tip adjacent to what the clinician believes to be an appropriate region of the endocardium based on tactile feedback, mapping electrocardiogram (ECG) signals, anatomy, and/or fluoroscopic imaging, actuates flow of an irrigant to cool the surface of the selected region, and then actuates the ablative tip for a period of time and at a power believed sufficient to destroy tissue in the selected region.

[0003] Successful electrophysiology procedures require precise knowledge about the anatomic substrate. Additionally, ablation procedures may be evaluated within a short period of time after their completion. Cardiac ablation catheters typically carry only regular mapping electrodes. Cardiac ablation catheters may incorporate high-resolution mapping electrodes. Such high-resolution mapping electrodes provide more accurate and more detailed information about the anatomic substrate and about the outcome of ablation procedures.

SUMMARY

[0004] According to some embodiments, a device for high-resolution mapping and ablating targeted tissue of subject comprises an elongate body (e.g., a catheter, another medical instrument, etc.) having a proximal end and a distal end, a first high-resolution electrode portion positioned on the elongate body, at least a second electrode portion positioned adjacent the first electrode portion, the first and second electrode portions being configured to contact tissue of a subject and deliver radiofrequency energy sufficient to at least partially ablate the tissue, and at least one electrically insulating gap positioned between the first electrode portion and the second electrode portion, the at least one electrically insulating gap comprising a gap width separating the first and second electrode portions, wherein the first electrode portion is configured to electrically couple to the second electrode portion using a filtering element, wherein the filtering element is configured to present a low impedance at a frequency used for delivering ablative energy via the first and second electrode portions, wherein the device is configured to be positioned

within targeted tissue of the subject to obtain high-resolution mapping data related to said tissue when ablative energy is not delivered to the first and second electrode portions, wherein, based in part of the obtained mapping data, the device is configured to ablate one or more regions of the subject's targeted tissue once ablative energy is delivered to the first and said electrode portions, and wherein the device is used as a roving device in conjunction with a separate mapping device or system to provide mapping data in tissue regions not adequately covered by said separate mapping system, wherein the separate mapping device or system comprises a plurality of mapping electrodes.

[0005] According to some embodiments, the device additionally includes at least one separator positioned within the at least one electrically insulating gap, wherein the elongate body comprises at least one irrigation passage, said at least one irrigation passage extending to the first electrode portion, wherein electrically separating the first and second electrode portions facilitates high-resolution mapping along a targeted anatomical area, wherein the filtering element comprises a capacitor, wherein the device comprises the filtering element, the filtering element, wherein the filtering element is included on or within the elongate body, wherein the mapping electrodes of the separate mapping device or system are unipolar or bipolar electrodes, and wherein the separate mapping device or system comprises a plurality of mapping electrodes.

[0006] According to some embodiments, electrically separating the first and second electrode portions facilitates high-resolution mapping along a targeted anatomical area, and the separate mapping device or system comprises a plurality of mapping electrodes (e.g., a multi-electrode mapping system).

[0007] According to some embodiments, the device is used as a roving device in conjunction with a separate mapping device or system to provide mapping data in tissue regions not adequately covered by said separate mapping system. In some embodiments, the separate mapping device or system comprises a plurality of mapping electrodes (e.g., unipolar or bipolar electrodes). In some embodiments, the device comprises the filtering element. In one embodiment, the filtering element is separate from the device. In some embodiments, the filtering element is included on or within the elongate body. In some embodiments, the filtering element is included on or within a proximal handle secured to the elongate body. In several arrangements, the filtering element is included on or within a generator configured to supply power to the first high-resolution electrode portion and the at least a second electrode portion.

[0008] According to some embodiments, the device additionally comprises a means for facilitating high-resolution mapping. In some embodiments, electrically separating the first and second electrode portions facilitates high-resolution mapping along a targeted anatomical area.

[0009] According to some embodiments, the device further includes at least one separator positioned within the at least one electrically insulating gap. In one embodiment, the at least one separator contacts a proximal end of the first electrode portion and the distal end of the second electrode portion. In some embodiments, the filtering element comprises a capacitor. In some embodiments, the capacitor comprises a capacitance of 50 to 300 nF (e.g., approximately 100 nF, 50-75, 75-100, 100-150, 150-200, 200-250, 250-300 nF, ranges between the foregoing, etc.). In one embodiment, the capacitor comprises a capacitance of 100 nF. In some arrangements, a series impedance of lower than about 3 ohms

(Ω) is introduced across the first and second electrodes in the operating RF frequency range. In some embodiments, the operating RF frequency range is 300 kHz to 10 MHz. In some embodiments, the filtering element comprises a LC circuit.

[0010] According to some embodiments, the device additionally includes at least one conductor configured to electrically couple an energy delivery module to at least one of the first and second electrode portions. In one embodiment, the at least one conductor is electrically coupled to an energy delivery module.

[0011] According to some embodiments, a frequency of energy provided to the first and second electrode portions is in the radiofrequency range. In some embodiments, a series impedance introduced across the first and second electrode portions is lower than: (i) an impedance of a conductor that electrically couples the electrodes to an energy delivery module, and (ii) an impedance of a tissue being treated. In some embodiments, the gap width is approximately 0.2 to 1.0 mm (e.g., 0.2-0.3, 0.3-0.4, 0.4-0.5, 0.5-0.6, 0.6-0.7, 0.7-0.8, 0.8-0.9, 0.9-1 mm, lengths between the foregoing ranges, etc.). In one embodiment, the gap width is 0.5 mm. In some embodiments, the gap width is approximately 0.2 to 1.0 mm (e.g., 0.2-0.3, 0.3-0.4, 0.4-0.5, 0.5-0.6, 0.6-0.7, 0.7-0.8, 0.8-0.9, 0.9-1.0 mm, widths between the foregoing, etc.).

[0012] According to some embodiments, the elongate body comprises at least one irrigation passage, the at least one irrigation passage extending to the first electrode portion. In some embodiments, the first electrode comprises at least one outlet port in fluid communication with the at least one irrigation passage. In one embodiment, the mapping electrodes of the separate mapping device or system are unipolar or bipolar electrodes.

[0013] According to some embodiments, the device is configured to determine whether tissue has been properly ablated. In some embodiments, a determination of whether tissue has been properly ablated is determined by comparing the amplitude of an electrogram obtained using the first and second electrode portions to a baseline electrogram amplitude.

[0014] According to some embodiments, a method of mapping targeted anatomical tissue of a subject and delivering energy to at least an area of said anatomical tissue comprises positioning a high-resolution tip or high-resolution section electrode located on a catheter, the high-resolution tip or high-resolution section electrode comprising a first electrode portion and a second electrode portion, wherein an electrically insulating gap is positioned between the first electrode portion and the second electrode portion, the electrically insulating gap comprising a gap width separating the first and second electrode portions, wherein a filtering element electrically couples the first electrode to the second electrode portion, and wherein electrically separating the first and second electrode portions facilitates high-resolution mapping along a targeted anatomical area

[0015] According to some embodiments, the catheter comprises the filtering element. In some embodiments, the filtering element is separate from the catheter. In some embodiments, the method further includes receiving high-resolution mapping data from the first and second electrode portions, the high-resolution mapping data relating to tissue of a subject adjacent the first and second electrode portions. In some embodiments, the high-resolution-tip or high-resolution-section electrode is positioned in regions of a subject's tissue not mapped by a separate mapping device or system. In some

embodiments, the high-resolution-tip or high-resolution-section electrode is positioned without the use or assistance of a separate mapping device or system.

[0016] According to some embodiments, the first and second electrode portions are configured to contact tissue of a subject and selectively deliver energy sufficient to at least partially ablate tissue. In some embodiments, selectively delivering energy sufficient to at least partially ablate tissue is based, at least in part, of the high-resolution mapping of the targeted anatomical area obtained by the high-resolution tip or high-resolution section electrode located on the catheter. In one embodiment, receiving high-resolution mapping data occurs prior to, during or after energizing a high-resolution tip electrode positioned on a catheter.

[0017] According to some embodiments, the method additionally includes comprising determining whether tissue being mapped has been properly ablated. In some embodiments, determining whether tissue has been properly ablated comprises comparing the amplitude of an electrogram obtained using the first and second electrode portions to a baseline electrogram amplitude.

[0018] According to some embodiments, a method of mapping tissue of a subject comprises receiving high-resolution mapping data using a high-resolution-tip or high-resolution-section electrode, said high-resolution-tip or high-resolution-section electrode comprising first and second electrode portions, wherein the high-resolution-tip or high-resolution-section electrode comprises a first electrode portion and a second electrode portion separated by an electrically insulating gap, wherein a filtering element electrically couples the first electrode portion to the second electrode portion in the operating RF range, and wherein electrically insulating the first and second electrode portions facilitates high-resolution mapping along a targeted anatomical area.

[0019] According to some embodiments, the filtering element is positioned adjacent the high-resolution-tip or the high-resolution-section electrode. In some embodiments, the filtering element is separate or away from the high-resolution-tip or the high-resolution-section electrode. In some embodiments, the method further comprises energizing the high-resolution-tip or high-resolution-section electrode to selectively deliver energy sufficient to at least partially ablate the tissue of the subject.

[0020] According to some embodiments, the high-resolution mapping data relates to tissue of a subject adjacent the first and second electrode portions. In some embodiments, receiving high-resolution mapping data occurs prior to, during or after energizing a high-resolution tip or a high-resolution section electrode positioned on a catheter. In one embodiment, the mapping data is provided to an electrophysiology recorder.

[0021] According to some embodiments, a frequency of energy provided to the first and second electrodes is in the radiofrequency range. In some embodiments, the filtering element comprises a capacitor. In some embodiments, the capacitor comprises a capacitance of 50 to 300 nF (e.g., approximately 100 nF, 50-75, 75-100, 100-150, 150-200, 200-250, 250-300 nF, etc.). In one embodiment, the capacitor comprises a capacitance of 100 nF. In some arrangements, a series impedance of lower than about 3 ohms (Ω) is introduced across the first and second electrodes in the operating RF frequency range. In some embodiments, the operating RF frequency range is 300 kHz to 10 MHz. In some embodiments, the filtering element comprises a LC circuit.

[0022] According to some embodiments, a device on which the high-resolution-tip or high-resolution-section electrode is positioned is used as a roving device in conjunction with a separate mapping device or system to provide mapping data in tissue regions not adequately covered by said separate mapping device or system. In some embodiments, the separate mapping device or system comprises a plurality of mapping electrodes. In some embodiments, the mapping electrodes of the separate mapping device or system are unipolar or bipolar electrodes.

[0023] According to some embodiments, a device on which the high-resolution-tip or high-resolution-section electrode is positioned is configured to determine whether tissue has been properly ablated. In some embodiments, a determination of whether tissue has been properly ablated is determined by comparing the amplitude of an electrogram obtained using the first and second electrode portions to a baseline electrogram amplitude.

[0024] According to some embodiments, a system for obtaining mapping data for a targeted anatomical tissue of a subject comprises a data acquisition device configured to receive mapping data from a first device, the first device comprising at least one high-resolution electrode configured to map tissue along the targeted anatomical tissue, wherein the data acquisition device is further configured to receive mapping data from a second device, the second device comprising a plurality of mapping electrodes, and a processor configured to generate a three-dimensional map using the mapping data received by the data acquisition device from the first and second devices.

[0025] According to some embodiments, the first device comprises a catheter. In one embodiment, the catheter comprises a high-resolution-tip electrode. In some embodiments, the second device comprises at least one expandable member, wherein at least some of the plurality of mapping electrodes are positioned along the at least one expandable member. In some embodiments, the mapping data received from the second device comprise unipolar signals. In some embodiments, the mapping data received from the second device comprise bipolar signals.

[0026] According to some embodiments, the processor is configured to align or synchronize data obtained from the first and second devices. In some embodiments, the processor is configured to couple to an output device for displaying the three-dimensional map. In one embodiment, the system comprises the output device (e.g., monitor).

[0027] According to some embodiments, the system further comprises the first device and/or the second devices. In some embodiments, the data acquisition device and the processor are combined in a single assembly. In other arrangements, the data acquisition device and the processor are separate.

[0028] According to some embodiments, a system for obtaining mapping data for a targeted anatomical tissue of a subject comprises a catheter including at least one high-resolution electrode configured to map tissue along the targeted anatomical tissue, and a data acquisition device configured to receive mapping data from the catheter, wherein the data acquisition device is configured to couple to a separate mapping device, the data acquisition device being configured to receive mapping data from the separate mapping device, wherein the separate mapping device comprises a plurality of mapping electrodes. The system additionally includes a processor configured to generate a three-dimensional map from

the mapping data received from the catheter and the separate mapping device by the data acquisition device.

[0029] According to some embodiments, the catheter comprises a high-resolution-tip electrode. In some embodiments, the separate mapping system comprises at least one expandable member, wherein at least some of the plurality of mapping electrodes are positioned along the at least one expandable member. In some embodiments, the mapping data received from the separate mapping device comprise unipolar signals. In some embodiments, the mapping data received from the separate mapping device comprise bipolar signals. In some embodiments, the processor is configured to align or synchronize mapping data obtained from the catheter and the separate mapping device. In some embodiments, the processor is configured to couple to an output device for displaying the three-dimensional map. In one embodiment, the system comprises the output device (e.g., one or more monitors). In some embodiments, the processor is integrated within the data acquisition device. In other embodiments, the processor is separate from the data acquisition device.

[0030] According to some embodiments, a system for obtaining mapping data for a targeted anatomical tissue of a subject comprises a data acquisition device configured to receive mapping data from a mapping catheter, and a processor configured to receive mapping data from the data acquisition device and from a separate mapping system, wherein the separate mapping system is configured to operatively couple to the processor, the separate mapping system comprising a plurality of mapping electrodes, and wherein the processor is configured to generate a three-dimensional map from such mapping data.

[0031] According to some embodiments, the system is configured to operatively couple to an output device for displaying said three-dimensional map. In some embodiments, the system further includes the output device (e.g., one or more monitors or other displays). In some embodiments, the at least one electrode of the catheter comprises a high-resolution-tip electrode. In some embodiments, the at least one electrode of the catheter comprises a bipolar electrode.

[0032] According to some embodiments, the separate mapping device comprises at least one expandable member (e.g., strut, wire, cage, etc.), the at least one expandable member comprising at least one of the plurality of mapping electrodes. In some embodiments, the separate mapping device comprises an expandable basket or other expandable structure. In some embodiments, at least one of the mapping electrodes of the separate mapping device comprises a bipolar electrode. In some embodiments, at least one of the mapping electrodes of the separate mapping device comprises a unipolar electrode. In some embodiments, the separate mapping device is configured to work with at least one reference electrode in order to generate the mapping data for the separate mapping device. In one embodiment, the at least one reference electrode is located external to the subject. In some embodiments, the at least one reference electrode is located internal to the subject. In some embodiments, the at least one reference electrode is located within a lumen of a subject. In some embodiments, the lumen of the subject comprises a superior vena cava of the subject.

[0033] According to some embodiments, the processor is configured to align or synchronize data obtained from the catheter and from the separate device. In some embodiments, the system further comprises a user input device (e.g., touchscreen, other keyboard or keypad, a computer, etc.) that

allows a user to input information or data. In some embodiments, the processor is configured to operatively couple to a user input device, the user input device allowing a user to input information or data. In one embodiment, the user input device is incorporated into the output device. In some embodiments, the user input device is separate from the output device.

[0034] According to some embodiments, the at least one high-resolution electrode comprises a first high-resolution electrode portion. In some embodiments, the processor is integrated within the data acquisition device. In some embodiments, the processor is separate from the data acquisition device.

[0035] According to some embodiments, the system further includes the catheter. In some embodiments, the catheter comprises at least one high-resolution electrode configured to map tissue along the targeted anatomical tissue. In some embodiments, the separate mapping system comprises a separate data acquisition device, the separate data acquisition device being configured to receive data from the plurality of mapping electrodes of said separate mapping system. In one embodiment, the separate data acquisition system is configured to operatively couple to the processor.

[0036] According to some embodiments, a method of enhancing a map of a targeted anatomical region includes receiving mapping data from a first mapping device or system, the first mapping device or system comprising a plurality of mapping electrodes, receiving high-resolution mapping data from a second mapping system, the second mapping system being configured to be moved to locations between the plurality of mapping electrodes of the first mapping system to obtain said high-resolution mapping data, wherein the second mapping device or system comprises a roving system that can be selectively positioned along a targeted anatomical region of a subject, processing the mapping data obtained by the first and second mapping devices or systems using a processor, wherein the second mapping device or system is configured to supplement and refine a map of the targeted anatomical region, and creating an enhanced three-dimensional map using the processor with the data obtained by the first and second mapping devices or systems.

[0037] According to some embodiments, the method further comprises displaying the three-dimensional map (e.g., on a monitor or other display). In some embodiments, the method further comprises aligning or synchronizing the data obtained from the plurality of mapping electrodes of the first mapping device or system and from the high-resolution roving device or system. In some embodiments, the high-resolution mapping data is obtained using a high-resolution electrode of the second mapping device or system. In some embodiments, the data from the plurality of mapping electrodes comprise unipolar signals. In some embodiments, the data from the plurality of mapping electrodes comprise bipolar signals.

[0038] According to some embodiments, the first mapping device or system comprises at least one expandable member, wherein at least some of the mapping electrodes are located on the at least one expandable member. In some embodiments, the targeted anatomical region is located along or near the heart of a subject. In some embodiments, the targeted anatomical region comprises cardiac tissue. In some embodiments, the three-dimensional map comprising at least one of an activation map, a propagation velocity map, a voltage map and a rotor map.

[0039] According to some embodiments, a method of creating an enhanced map of a targeted anatomical region includes collecting a first mapping data set from a plurality of mapping electrodes, collecting a second mapping data set from a high-resolution roving electrode being configured to be moved to locations between the plurality of mapping electrodes, aligning or synchronizing the first and second mapping data sets, and generating an enhanced three-dimensional map using the aligned or synchronized first and second mapping data sets.

[0040] According to some embodiments, the method further includes displaying the enhanced three-dimensional map. In one embodiment, data related to the enhanced three-dimensional map are provided to an output device (e.g., monitor or other display) for displaying the three-dimensional map. In some embodiments, the data from the plurality of mapping electrodes comprise unipolar signals. In some embodiments, the data from the plurality of mapping electrodes of the first mapping system comprise bipolar signals.

[0041] According to some embodiments, the plurality of mapping electrodes are part of a multi-electrode mapping device or system, the multi-electrode device or system comprising at least one expandable member, wherein at least some of the mapping electrodes are located on the at least one expandable member. In some embodiments, the roving system comprises a catheter, the catheter comprising at least one mapping electrode. In one embodiment, the targeted anatomical region is located along or near the heart of a subject. In some embodiments, the targeted anatomical region comprises cardiac tissue. In some embodiments, the three-dimensional map comprising at least one of an activation map, a propagation velocity map, a voltage map and a rotor map. In some embodiments,

[0042] According to some embodiments, a kit for obtaining mapping data of tissue comprises a device for high-resolution mapping in accordance with any one of the device configurations disclosed herein, and a separate mapping device or system, wherein the separate mapping device or system comprises a plurality of mapping electrodes configured to map tissue of a subject, and wherein the device for high-resolution mapping provides mapping data in tissue regions not adequately covered by the separate mapping device or system.

[0043] According to some embodiments, a kit for obtaining mapping data of tissue comprises a device for high-resolution mapping, the device including an elongate body comprising a proximal end and a distal end, a first high-resolution electrode portion positioned on the elongate body, at least a second electrode portion positioned adjacent the first electrode portion, the first and second electrode portions being configured to contact tissue of a subject, and at least one electrically insulating gap positioned between the first electrode portion and the second electrode portion, the at least one electrically insulating gap comprising a gap width separating the first and second electrode portions, wherein the first electrode portion is configured to electrically couple to the second electrode portion using a filtering element, wherein the filtering element is configured to present a low impedance at a frequency used for delivering ablative energy via the first and second electrode portions, wherein the device is configured to be positioned within targeted tissue of the subject to obtain high-resolution mapping data related to said tissue when ablative energy is not delivered to the first and second electrode portions. The kit further comprising a separate mapping device or

system, wherein the separate mapping device or system comprises a plurality of mapping electrodes configured to map tissue of a subject, and wherein the device for high-resolution mapping provides mapping data in tissue regions not adequately covered by the separate mapping device or system.

[0044] According to some embodiments, the kit further includes a data acquisition device configured to receive mapping data from the device, wherein the data acquisition device is further configured to receive mapping data from the separate mapping device or system. In some embodiments, the kit additionally comprises a processor configured to generate a three-dimensional map using the mapping data received by the data acquisition device from the device and from the separate mapping device or system. In some embodiments, the separate mapping device or system comprises at least one expandable member, wherein at least some of the plurality of mapping electrodes are positioned along the at least one expandable member.

[0045] According to some embodiments, the mapping data received from the separate mapping device or system comprise unipolar signals. In some embodiments, the mapping data received from the separate mapping device or system comprise bipolar signals. In some embodiments, the processor is configured to align or synchronize data obtained from the device and the separate mapping device or system. In some embodiments, the processor is configured to couple to an output device for displaying the three-dimensional map.

[0046] According to some embodiments, a processor for receiving and processing data received from separate mapping devices or systems comprises a first port configured to operatively connect to a first device for high-resolution mapping, the device comprising a catheter and an electrode assembly for receiving high-resolution mapping data, and a second port configured to operatively connect to a second mapping device or system, the second mapping device or system comprising a plurality of electrodes that are configured to contact various portions along a targeted region of tissue being mapped, wherein the processor is configured to combine mapping data obtained from the first device and from the second mapping device or system, and wherein the processor is configured to align the mapping data received from the first device and the second mapping device or system to enable for the generation of a more complete three-dimensional map of tissue being mapped. In some embodiments, the processor is configured to be operatively coupled to an output device (e.g., at least one monitor or other display) for displaying the three-dimensional map created from data of both the first device and the second device or system.

[0047] According to some embodiments, a generator for selectively delivering energy to an ablation device comprises a processor according to any one of the embodiments disclosed herein, and an energy delivery module configured to generate ablative energy for delivery to an ablation device, wherein ablative energy generated by the energy delivery module is delivered to and through the first device to the electrode assembly of the first device. In some embodiments, the energy delivery module is configured to generate radiofrequency (RF) energy. In some embodiments, the processor and the energy delivery module are located within a single housing or enclosure. In some embodiments, the processor and the energy delivery module are located within separate housings or enclosures.

BRIEF DESCRIPTION OF THE DRAWINGS

[0048] These and other features, aspects and advantages of the present application are described with reference to drawings of certain embodiments, which are intended to illustrate, but not to limit, the concepts disclosed herein. The attached drawings are provided for the purpose of illustrating concepts of at least some of the embodiments disclosed herein and may not be to scale.

[0049] FIG. 1 schematically illustrates one embodiment of an energy delivery system configured to selectively ablate or otherwise heat targeted tissue of a subject;

[0050] FIG. 2 illustrates a side view of a system's catheter comprising a high-resolution-tip design according to one embodiment;

[0051] FIG. 3 illustrates a side view of a system's catheter comprising a high-resolution-tip design according to another embodiment;

[0052] FIG. 4 illustrates a side view of a system's catheter comprising a high-resolution-tip design according to yet another embodiment;

[0053] FIG. 5 illustrates an embodiment of a system's catheter comprising two high-resolution-section electrodes each consisting of separate sections circumferentially distributed on the catheter shaft;

[0054] FIG. 6 schematically illustrates one embodiment of a high-pass filtering element consisting of a coupling capacitor. The filtering element can be incorporated into a system's catheter that comprises a high-resolution-tip design;

[0055] FIG. 7 schematically illustrates one embodiment of four high-pass filtering elements comprising coupling capacitors. The filtering elements can operatively couple, in the operating RF frequency range, the separate electrode sections of a system's catheter electrodes, e.g., those illustrated in FIG. 5;

[0056] FIG. 8 illustrates embodiments of EKGs obtained from a high-resolution-tip electrode systems disclosed herein configured to detect whether an ablation procedure has been adequately performed;

[0057] FIG. 9 illustrates one embodiment of a commercially-available mapping system comprising a plurality of mapping electrodes;

[0058] FIG. 10 illustrates one embodiment of intermediate locations that can be mapped by an embodiment of a high-resolution-tip system disclosed herein to obtain a more accurate and comprehensive map of treated tissue;

[0059] FIG. 11 illustrates a schematic of a mapping system configured to obtain tissue mapping data using at least two different devices according to one embodiment;

[0060] FIG. 12 schematically illustrates one embodiment of an enhanced mapping system that includes a mapping system having a plurality of mapping electrodes and a roving system;

[0061] FIG. 13 illustrates one embodiment of an algorithm used by an enhanced mapping system to create an enhanced 3D map of a targeted anatomical region being mapped;

[0062] FIG. 14 illustrates electrocardiograms received from two different mapping devices of a system, according to one embodiment;

[0063] FIG. 15A illustrates one embodiment of a 3D tissue map obtained using only a multi-electrode mapping system;

[0064] FIG. 15B illustrates the 3D tissue map of FIG. 15A that has been enhanced by high-resolution data obtained using a second mapping device, according to one embodiment;

[0065] FIG. 16 schematically illustrates an alternate embodiment of a filtering element comprising a circuit configured to be used with any of the devices and systems disclosed herein to facilitate high resolution mapping; and

[0066] FIG. 17 illustrates one embodiment of a chart depicting impedance magnitude at different frequencies for the filtering element of FIG. 16.

DETAILED DESCRIPTION

[0067] According to some embodiments, successful electrophysiology procedures require precise knowledge about the anatomic substrate being targeted. Additionally, it may be desirable to evaluate the outcome of an ablation procedure within a short period of time after the execution of the procedure (e.g., to confirm that the desired clinical outcome was achieved). Typically, ablation catheters include only regular mapping electrodes (e.g., ECG electrodes). However, in some embodiments, it may be desirable for such catheters to incorporate high-resolution mapping capabilities. In some arrangements, high-resolution mapping electrodes can provide more accurate and more detailed information about the anatomic substrate and about the outcome of ablation procedures. For example, such high-resolution mapping electrodes can allow the electrophysiology (EP) practitioner to evaluate the morphology of electrograms, their amplitude and width and/or to determine changes in pacing thresholds. According to some arrangements, morphology, amplitude and/or pacing threshold are accepted as reliable EP markers that provide useful information about the outcome of ablation.

[0068] Several embodiments disclosed herein are particularly advantageous because they include one, several or all of the following benefits or advantages: reducing proximal edge heating, reducing the likelihood of char formation, providing for feedback that may be used to adjust ablation procedures in real time, providing noninvasive temperature measurements, providing for the creation of a more complete and comprehensive map (e.g., three-dimensional map) of tissue being evaluated, providing for more targeted ablation of tissue to treat a condition (e.g., atrial fibrillation, other cardiac arrhythmias, etc.) based on the more complete map of tissue, providing for integration (e.g., seamless or near seamless integration) with a separate mapping system, providing safer and more reliable ablation procedures and/or the like.

[0069] According to some embodiments, various implementations of electrodes (e.g., radiofrequency or RF electrodes) that can be used for high-resolution mapping are disclosed herein. For example, as discussed in greater detail herein, an ablation or other energy delivery system can comprise a high-resolution-tip design, wherein the energy delivery member (e.g., radiofrequency electrode) comprises two or more separate electrodes or electrode portions. As also discussed herein, in some embodiments, such separate electrodes or electrode portions can be advantageously electrically coupled to each other (e.g., to collectively create the desired heating or ablation of targeted tissue).

[0070] FIG. 1 schematically illustrates one embodiment of an energy delivery system 10 that is configured to selectively ablate, stimulate, modulate and/or otherwise heat or treat targeted tissue (e.g., cardiac tissue, pulmonary vein, other vessels or organs, etc.). Although certain embodiments disclosed herein are described with reference to ablation systems and methods, any of the systems and methods can be used to stimulate, modulate, heat and/or otherwise affect tissue, with or without partial or complete ablation, as desired or required.

As shown, the system 10 can include a medical instrument 20 (e.g., catheter) comprising one or more energy delivery members 30 (e.g., radiofrequency electrodes) along a distal end of the medical instrument 20. The medical instrument can be sized, shaped and/or otherwise configured to be passed intraluminally (e.g., intravascularly) through a subject being treated. In various embodiments, the medical instrument 20 comprises a catheter, a shaft, a wire, and/or other elongate instrument. In other embodiments, the medical instrument is not positioned intravascularly but is positioned extravascularly via laparoscopic or open surgical procedures. In various embodiments, the medical instrument 20 comprises a catheter, a shaft, a wire, and/or other elongate instrument. In some embodiments, one or more temperature sensing devices or systems 60 (e.g., thermocouples, thermistors, etc.) may be included at the distal end of the medical instrument 20, or along its elongate shaft or in its handle. The term “distal end” does not necessarily mean the distal terminus or distal end. Distal end could mean the distal terminus or a location spaced from the distal terminus but generally at a distal end portion of the medical instrument 20.

[0071] In some embodiments, the medical instrument 20 is operatively coupled to one or more devices or components. For example, as depicted in FIG. 1, the medical instrument 20 can be coupled to a delivery module 40 (such as an energy delivery module). According to some arrangements, the energy delivery module 40 includes an energy generation device 42 that is configured to selectively energize and/or otherwise activate the energy delivery member(s) 30 (for example, radiofrequency electrodes) located along the medical instrument 20. In some embodiments, for instance, the energy generation device 42 comprises a radiofrequency generator, an ultrasound energy source, a microwave energy source, a laser/light source, another type of energy source or generator, and the like, and combinations thereof. In other embodiments, energy generation device 42 is substituted with or use in addition to a source of fluid, such as a cryogenic fluid or other fluid that modulates temperature. Likewise, the delivery module (e.g., delivery module 40), as used herein, can also be a cryogenic device or other device that is configured for thermal modulation.

[0072] With continued reference to the schematic of FIG. 1, the energy delivery module 40 can include one or more input/output devices or components 44, such as, for example, a touchscreen device, a screen or other display, a controller (e.g., button, knob, switch, dial, etc.), keypad, mouse, joystick, trackpad, or other input device and/or the like. Such devices can permit a physician or other user to enter information into and/or receive information from the system 10. In some embodiments, the output device 44 can include a touchscreen or other display that provides tissue temperature information, contact information, other measurement information and/or other data or indicators that can be useful for regulating a particular treatment procedure.

[0073] According to some embodiments, the energy delivery module 40 includes a processor 46 (e.g., a processing or control unit) that is configured to regulate one or more aspects of the treatment system 10. The module 40 can also comprise a memory unit or other storage device 48 (e.g., computer readable medium) that can be used to store operational parameters and/or other data related to the operation of the system 10. In some embodiments, the processor 46 is configured to automatically regulate the delivery of energy from the energy generation device 42 to the energy delivery member

30 of the medical instrument **20** based on one or more operational schemes. For example, energy provided to the energy delivery member **30** (and thus, the amount of heat transferred to or from the targeted tissue) can be regulated based on, among other things, the detected temperature of the tissue being treated.

[0074] According to some embodiments, the energy delivery system **10** can include one or more temperature detection devices, such as, for example, reference temperature devices (e.g., thermocouples, thermistors, etc.) and/or the like. For example, in some embodiments, the device further comprises a one or more temperature sensors or other temperature-measuring devices to help determine a peak (e.g., high or peak, low or trough, etc.) temperature of tissue being treated. In some embodiments, the temperature sensors (e.g., thermocouples) located at, along and/or near the ablation member (e.g., RF electrode) can help with the determination of whether contact is being made between the ablation member and targeted tissue (and/or to what degree such contact is being made). In some embodiments, such peak temperature is determined without the use of radiometry.

[0075] With reference to FIG. 1, the energy delivery system **10** comprises (or is in configured to be placed in fluid communication with) an irrigation fluid system **70**. In some embodiments, as schematically illustrated in FIG. 1, such a fluid system **70** is at least partially separate from the energy delivery module **40** and/or other components of the system **10**. However, in other embodiments, the irrigation fluid system **70** is incorporated, at least partially, into the energy delivery module **40**. The irrigation fluid system **70** can include one or more pumps or other fluid transfer devices that are configured to selectively move fluid through one or more lumens or other passages of the catheter **20**. Such fluid can be used to selectively cool (e.g., transfer heat away from) the energy delivery member **30** during use.

[0076] FIG. 2 illustrates one embodiment of a distal end of a medical instrument (e.g., catheter) **20**. As shown, the catheter **20** can include a high-resolution tip design, such that there are two adjacent electrodes or two adjacent electrode portions **30A**, **30B** separated by a gap **G**. According to some embodiments, as depicted in the configuration of FIG. 2, the relative length of the different electrodes or electrode portions **30A**, **30B** can vary. For example, the length of the proximal electrode **30B** can be between 1 to 20 times (e.g., 1-2, 2-3, 3-4, 4-5, 5-6, 6-7, 7-8, 8-9, 9-10, 10-11, 11-12, 12-13, 13-14, 14-15, 15-16, 16-17, 17-18, 18-19, 19-20, values between the foregoing ranges, etc.) the length of the distal electrode **30A**, as desired or required. In other embodiments, the length of the proximal electrode **30B** can be greater than 20 times (e.g., 20-25, 25-30, more than 30 times, etc.) the length of the distal electrode **30A**. In yet other embodiments, the lengths of the distal and proximal electrodes **30A**, **30B** are about equal. In some embodiments, the distal electrode **30A** is longer than the proximal electrode **30B** (e.g., by 1 to 20 times, such as, for example, 1-2, 2-3, 3-4, 4-5, 5-6, 6-7, 7-8, 8-9, 9-10, 10-11, 11-12, 12-13, 13-14, 14-15, 15-16, 16-17, 17-18, 18-19, 19-20, values between the foregoing ranges, etc.).

[0077] In some embodiments, the distal electrode or electrode portion **30A** is 0.5 mm long. In other embodiments, the distal electrode or electrode portion **30A** is between 0.1 mm and 1 mm long (e.g., 0.1-0.2, 0.2-0.3, 0.3-0.4, 0.4-0.5, 0.5-0.6, 0.6-0.7, 0.7-0.8, 0.8-0.9, 0.9-1 mm, values between the foregoing ranges, etc.). In other embodiments, the distal electrode or electrode portion **30A** is greater than 1 mm in length,

as desired or required. In some embodiments, the proximal electrode or electrode portion **30B** is 2 to 4 mm long (e.g., 2-2.5, 2.5-3, 3-3.5, 3.5-4 mm, lengths between the foregoing, etc.). However, in other embodiments, the proximal electrode portion **30B** is greater than 4 mm (e.g., 4-5, 5-6, 6-7, 7-8, 8-9, 9-10 mm, greater than 10 mm, etc.) or smaller than 1 mm (e.g., 0.1-0.5, 0.5-1, 1-1.5, 1.5-2 mm, lengths between the foregoing ranges, etc.), as desired or required. In embodiments where the high-resolution electrodes are located on catheter shafts, the length of the electrodes can be 1 to 5 mm (e.g., 1-2, 2-3, 3-4, 4-5 mm, lengths between the foregoing, etc.). However, in other embodiments, the electrodes can be longer than 5 mm (e.g., 5-6, 6-7, 7-8, 8-9, 9-10, 10-15, 15-20 mm, lengths between the foregoing, lengths greater than 20 mm, etc.), as desired or required.

[0078] As noted above, the use of a high-resolution tip design can permit a user to simultaneously ablate or otherwise thermally treat targeted tissue and map (e.g., using high-resolution mapping) in a single configuration. Thus, such systems can advantageously permit precise high-resolution mapping (e.g., to confirm that a desired level of treatment occurred) during a procedure. In some embodiments, the high-resolution tip design that includes two electrodes or electrode portions **30A**, **30B** can be used to record a high-resolution bipolar electrogram. For such purposes, the two electrodes or electrode portions can be connected to the inputs of an EP recorder. In some embodiments, a relatively small separation distance (e.g., gap **G**) between the electrodes or electrode portions **30A**, **30B** enables high-resolution mapping.

[0079] In some embodiments, a medical instrument (e.g., a catheter) **20** can include three or more electrodes or electrode portions (e.g., separated by gaps), as desired or required. Additional details regarding such arrangements are provided below. According to some embodiments, regardless of how many electrodes or electrode portions are positioned along a catheter tip, the electrodes or electrode portions **30A**, **30B** are radiofrequency electrodes and comprise one or more metals, such as, for example, stainless steel, platinum, platinum-iridium, gold, gold-plated alloys and/or the like.

[0080] According to some embodiments, as illustrated in FIG. 2, the electrodes or electrode portions **30A**, **30B** are spaced apart from each other (e.g., longitudinally or axially) using a gap (e.g., an electrically insulating gap). In some embodiments, the length of the gap **G** (or the separation distance between adjacent electrodes or electrode portions) is 0.5 mm. In other embodiments, the gap **G** or separation distance is greater or smaller than 0.5 mm, such as, for example, 0.1-1 mm (e.g., 0.1-0.2, 0.2-0.3, 0.3-0.4, 0.4-0.5, 0.5-0.6, 0.6-0.7, 0.7-0.8, 0.8-0.9, 0.9-1.0 mm, values between the foregoing ranges, less than 0.1 mm, greater than 1 mm, etc.), as desired or required.

[0081] According to some embodiments, a separator **34** is positioned within the gap **G**, between the adjacent electrodes or electrode portions **30A**, **30B**, as depicted in FIG. 2. The separator can comprise one or more electrically insulating materials, such as, for example, Teflon, polyetheretherketone (PEEK), polyetherimide resins (e.g., ULTEM™), ceramic materials, polyimide and the like.

[0082] As noted above with respect to the gap **G** separating the adjacent electrodes or electrode portions, the insulating separator **34** can be 0.5 mm long. In other embodiments, the length of the separator **34** can be greater or smaller than 0.5 mm (e.g., 0.1-0.2, 0.2-0.3, 0.3-0.4, 0.4-0.5, 0.5-0.6, 0.6-0.7,

0.7-0.8, 0.8-0.9, 0.9-1.0 mm, values between the foregoing ranges, less than 0.1 mm, greater than 1 mm, etc.), as desired or required.

[0083] According to some embodiments, as discussed in greater detail herein, to ablate or otherwise heat or treat targeted tissue of a subject successfully with the high-resolution tip electrode design, such as the one depicted in FIG. 2, the two electrodes or electrode portions 30A, 30B are electrically coupled to each other at the RF frequency. Thus, the two electrodes or electrode portions can advantageously function as a single longer electrode at the RF frequency.

[0084] FIGS. 3 and 4 illustrate different embodiments of catheter systems 100, 200 that incorporate a high-resolution tip design. For example, in FIG. 3, the electrode (e.g., radio-frequency electrode) along the distal end of the electrode comprises a first or distal electrode or electrode portion 110 and a second or proximal electrode or electrode portion 114. As shown and discussed in greater detail herein with reference to other configurations, the high-resolution tip design 100 includes a gap G between the first and second electrodes or electrode portions 110, 114. In some configurations, the second or proximal electrode or electrode portion 114 is generally longer than the first or distal electrode or electrode portion 110. For instance, the length of the proximal electrode 114 can be between 1 to 20 times (e.g., 1-2, 2-3, 3-4, 4-5, 5-6, 6-7, 7-8, 8-9, 9-10, 10-11, 11-12, 12-13, 13-14, 14-15, 15-16, 16-17, 17-18, 18-19, 19-20, values between the foregoing ranges, etc.) the length of the distal electrode 110, as desired or required. In other embodiments, the length of the proximal electrode can be greater than 20 times (e.g., 20-25, 25-30, more than 30 times, etc.) the length of the distal electrode. In yet other embodiments, the lengths of the distal and proximal electrodes are about the same. However, in some embodiments, the distal electrode 110 is longer than the proximal electrode 114 (e.g., by 1 to 20 times, such as, for example, 1-2, 2-3, 3-4, 4-5, 5-6, 6-7, 7-8, 8-9, 9-10, 10-11, 11-12, 12-13, 13-14, 14-15, 15-16, 16-17, 17-18, 18-19, 19-20, values between the foregoing ranges, etc.).

[0085] As shown in FIG. 3 and noted above, regardless of their exact design, relative length diameter, orientation and/or other characteristics, the electrodes or electrode portions 110, 114 can be separated by a gap G. The gap G can comprise a relatively small electrically insulating gap or space. In some embodiments, an electrically insulating separator 118 can be snugly positioned between the first and second electrodes or electrode portions 110, 114. In certain embodiments, the separator 118 can have a length of about 0.5 mm. In other embodiments, however, the length of the separator 118 can be greater or smaller than 0.5 mm (e.g., 0.1-0.2, 0.2-0.3, 0.3-0.4, 0.4-0.5, 0.5-0.6, 0.6-0.7, 0.7-0.8, 0.8-0.9, 0.9-1.0 mm, values between the foregoing ranges, less than 0.1 mm, greater than 1 mm, etc.), as desired or required. The separator can include one or more electrically insulating materials (e.g., materials that have an electrical conductivity less than about 1000 or less (e.g., 500-600, 600-700, 700-800, 800-900, 900-1000, 1000-1100, 1100-1200, 1200-1300, 1300-1400, 1400-1500, values between the foregoing, less than 500, greater than 1500, etc.) than the electrical conductivity of metals or alloys). The separator can comprise one or more electrically insulating materials, such as, for example, Teflon, polyetheretherketone (PEEK), polyoxymethylene, acetal resins or polymers and the like.

[0086] As shown in FIG. 3, the separator 118 can be cylindrical in shape and can have the identical or similar diameter

and configuration as the adjacent electrodes or electrode portions 110, 114. Thus, in some embodiments, the outer surface formed by the electrodes or electrode portions 110, 114 and the separator 118 can be generally uniform or smooth. However, in other embodiments, the shape, size (e.g., diameter) and/or other characteristics of the separator 118 can be different than one or more of the adjacent electrodes or electrode portions 110, 114, as desired or required for a particular application or use.

[0087] FIG. 4 illustrates an embodiment of a system 200 having three or more electrodes or electrode portions 210, 212, 214 separated by corresponding gaps G1, G2. The use of such additional gaps, and thus, additional electrodes or electrode portions 210, 212, 214 that are physically separated (e.g., by gaps) yet in close proximity to each other, can provide additional benefits to the high-resolution mapping capabilities of the system. For example, the use of two (or more) gaps can provide more accurate high-resolution mapping data related to the tissue being treated. Such multiple gaps can provide information about the directionality of cardiac signal propagation. In addition, high-resolution mapping with high-resolution electrode portions involving multiple gaps can provide a more extended view of lesion progression during the ablation process and higher confidence that viable tissue strands are not left behind within the targeted therapeutic volume. In some embodiments, high-resolution electrodes with multiple gaps can optimize the ratio of mapped tissue surface to ablated tissue surface. Preferably, such ratio is in the range of 0.2 to 0.8 (e.g., 0.2-0.3, 0.3-0.4, 0.4-0.5, 0.5-0.6, 0.6-0.7, 0.7-0.8, ratios between the foregoing, etc.). Although FIG. 4 illustrates an embodiment having a total of three electrodes or electrode portions 210, 212, 214 (and thus, two gaps G1, G2), a system can be designed or otherwise modified to comprise additional electrodes or electrode portions, and thus, additional gaps. For example, in some embodiments, an ablation or other treatment system can include 4 or more (e.g., 5, 6, 7, 8, more than 8, etc.) electrodes or electrode portions (and thus, 3 or more gaps, e.g., 3, 4, 5, 6, 7 gaps, more than 7 gaps, etc.), as desired or required. In such configurations, a gap (and/or an electrical separator) can be positioned between adjacent electrodes or electrode portions, in accordance with the embodiments illustrated in FIGS. 2 to 4.

[0088] As depicted in FIGS. 3 and 4, an irrigation tube 120, 220 can be routed within an interior of the catheter (not shown for clarity). In some embodiments, the irrigation tube 120, 220 can extend from a proximal portion of the catheter (e.g., where it can be placed in fluid communication with a fluid pump) to the distal end of the system. For example, in some arrangements, as illustrated in the side views of FIGS. 3 and 4, the irrigation tube 120, 220 extends and is in fluid communication with one or more fluid ports 211 that extend radially outwardly through the distal electrode 110, 210. Thus, in some embodiments, the treatment system comprises an open irrigation design, wherein saline and/or other fluid is selectively delivered through the catheter (e.g., within the fluid tube 120, 220) and radially outwardly through one or more outlet ports 111, 211 of an electrode 110, 210. The delivery of such saline or other fluid can help remove heat away from the electrodes and/or the tissue being treated. In some embodiments, such an open irrigation system can help prevent or reduce the likelihood of overheating of targeted tissue, especially along the tissue that is contacted by the electrodes. An open irrigation design is also incorporated in the system that is schematically illustrated in FIG. 2. For instance, as

depicted in FIG. 2, the distal electrode or electrode portion 34 can include a plurality of outlet ports 36 through which saline or other irrigation fluid can exit.

[0089] According to some embodiments, a catheter can include a high-resolution-tip electrode design that includes one or more gaps in the circumferential direction (e.g., radially), either in addition to or in lieu of gaps in the longitudinal direction. One embodiment of a system 300 comprising one or more electrodes 310A, 310B is illustrated in FIG. 5. As shown, in arrangements where two or more electrodes are included, the electrodes 310A, 310B can be longitudinally or axially offset from each other. For example, in some embodiments, the electrodes 310A, 310B are located along or near the distal end of a catheter. In some embodiments, the electrodes 310A, 310B are located along an exterior portion of a catheter or other medical instrument. However, in other configurations, one or more of the electrodes can be positioned along a different portion of the catheter or other medical instrument (e.g., along at least an interior portion of a catheter), as desired or required.

[0090] With continued reference to FIG. 5, each electrode 310A, 310B can comprises two or more sections 320A, 322A and/or 320B, 322B. As shown, in some embodiments, the each section 320A, 322A and/or 320B, 322B can extend half-way around (e.g., 180 degrees) the diameter of the catheter. However, in other embodiments, the circumferential extent of each section can be less than 180 degrees. For example, each section can extend between 0 and 180 degrees (e.g., 15, 30, 45, 60, 75, 90, 105, 120 degrees, degrees between the foregoing, etc.) around the circumference of the catheter along which it is mounted. Thus, in some embodiments, an electrode can include 2, 3, 4, 5, 6 or more circumferential sections, as desired or required.

[0091] Regardless of how the circumferential electrode sections are designed and oriented, electrically insulating gaps G can be provided between adjacent sections to facilitate the ability to use the electrode to conduct high-resolution mapping, in accordance with the various embodiments disclosed herein. Further, as illustrated in the embodiment of FIG. 5, two or more (e.g., 3, 4, 5, more than 5, etc.) electrodes 310A, 310B having two or more circumferential or radial sections can be included in a particular system 300, as desired or required.

[0092] In alternative embodiments, the various embodiments of a high-resolution tip design disclosed herein, or variations thereof, can be used with a non-irrigated system or a closed-irrigation system (e.g., one in which saline and/or other fluid is circulated through or within one or more electrodes to selectively remove heat therefrom). Thus, in some arrangements, a catheter can include two or more irrigation tubes or conduits. For example, one tube or other conduit can be used to deliver fluid toward or near the electrodes, while a second tube or other conduit can be used to return the fluid in the reverse direction through the catheter.

[0093] According to some embodiments, a high-resolution tip electrode is designed to balance the current load between the various electrodes or electrode portions. For example, if a treatment system is not carefully configured, the electrical load may be delivered predominantly to one or more of the electrodes or electrode portions of the high-resolution tip system (e.g., the shorter or smaller distal electrode or electrode portion). This can lead to undesirable uneven heating of the electrode, and thus, uneven heating (e.g., ablation) of the adjacent tissue of the subject. Thus, in some embodiments,

one or more load balancing configurations can be used to help ensure that the heating along the various electrodes or electrode portions of the system will be generally balanced. As a result, the high-resolution tip design can advantageously function more like a longer, single electrode, as opposed to two or more electrodes that receive an unequal electrical load (and thus, deliver an unequal amount of heat or level of treatment to the subject's targeted tissue).

[0094] One embodiment of a configuration that can be used to balance the electrical current load delivered to each of the electrodes or electrode portions in a high-resolution tip design is schematically illustrated in FIG. 6. As shown, one of the electrodes (e.g., the distal electrode) 30A can be electrically coupled to an energy delivery module 40 (e.g., a RF generator). As discussed herein, the module 40 can comprise one or more components or features, such as, for example, an energy generation device that is configured to selectively energize and/or otherwise activate the energy members (e.g., RF electrodes), one or more input/output devices or components, a processor (e.g., a processing or control unit) that is configured to regulate one or more aspects of the treatment system, a memory and/or the like. Further, such a module can be configured to be operated manually or automatically, as desired or required.

[0095] In the embodiment that is schematically depicted in FIG. 6, the distal electrode 30A is energized using one or more conductors 82 (e.g., wires, cables, etc.). For example, in some arrangements, the exterior of the irrigation tube 38 comprises and/or is otherwise coated with one or more electrically conductive materials (e.g., copper, other metal, etc.). Thus, as shown in FIG. 6, the conductor 82 can be placed in contact with such a conductive surface or portion of the tube 38 to electrically couple the electrode or electrode portion 30A to an energy delivery module. However, one or more other devices and/or methods of placing the electrode or electrode portion 30A in electrical communication with an energy delivery module can be used. For example, one or more wires, cables and/or other conductors can directly or indirectly couple to the electrodes, without the use of the irrigation tube.

[0096] With continued reference to FIG. 6, the first or distal electrode or electrode portion 30A can be electrically coupled to the second or proximal electrode or electrode portion 30B using one more band-pass filtering elements 84, such as a capacitor, a filter circuit (see, e.g., FIG. 16), etc. For instance, in some embodiments, the band-pass filtering element 84 comprises a capacitor that electrically couples the two electrodes or electrode portions 30A, 30B when radiofrequency current is applied to the system. In one embodiment, the capacitor 84 comprises a 100 nF capacitor that introduces a series impedance lower than about 3Ω at 500 kHz, which, according to some arrangements, is a target frequency for RF ablation. However, in other embodiments, the capacitance of the capacitor(s) or other band-pass filtering elements 84 that are incorporated into the system can be greater or less than 100 nF, for example, 5 nF to 300 nF, according to the operating RF frequency, as desired or required. In some embodiments, the capacitance of the filtering element 84 is selected based on a target impedance at a particular frequency or frequency range. For example, in some embodiments, the system can be operated at a frequency of 200 kHz to 10 MHz (e.g., 200-300, 300-400, 400-500, 500-600, 600-700, 700-800, 800-900, 900-1000 kHz, up to 10 MHz or higher frequencies between the foregoing ranges, etc.). Thus, the

capacitor that couples adjacent electrodes or electrode portions to each other can be selected based on the target impedance for a particular frequency. For example, a 100 nF capacitor provides about 3Ω of coupling impedance at an operating ablation frequency of 500 kHz.

[0097] In some embodiments, a series impedance of 3Ω across the electrodes or electrode portions **30A**, **30B** is sufficiently low when compared to the impedance of the conductor **82** (e.g., wire, cable, etc.), which can be about $5\text{-}10\Omega$, and the impedance of tissue, which can be about 100Ω , such that the resulting tissue heating profile is not negatively impacted when the system is in use. Thus, in some embodiments, a filtering element is selected so that the series impedance across the electrodes or electrode portions is lower than the impedance of the conductor that supplies RF energy to the electrodes. For example, in some embodiments, the insertion impedance of the filtering element is 50% of the conductor **82** impedance, or lower, or 10% of the equivalent tissue impedance, or lower.

[0098] In some embodiments, a filtering element (e.g., capacitor a filter circuit such as the one described herein with reference to FIG. 16, etc.) can be located at a variety of locations of the device or accompanying system. For example, in some embodiments, the filtering element is located on or within a catheter (e.g., near the distal end of the catheter, adjacent the electrode, etc.). In other embodiments, however, the filtering element is separate of the catheter. For instance, the filtering element can be positioned within or along a handle to which the catheter is secured, within the generator or other energy delivery module, within a separate processor or other computing device or component and/or the like).

[0099] Similarly, with reference to the schematic of FIG. 7, a filtering element **384** can be included in an electrode **310** comprising circumferentially-arranged portions **320**, **322**. In FIG. 7, the filtering element **384** permits the entire electrode **310** to be energized within RF frequency range (e.g., when the electrode is activated to ablate). One or more RF wires or other conductors **344** can be used to deliver power to the electrode from a generator or source. In addition, separate conductors **340** can be used to electrically couple the electrode **310** for mapping purposes.

[0100] In embodiments where the high-resolution-tip design (e.g., FIG. 4) comprises three or more electrodes or electrode portions, additional filtering elements (e.g., capacitors) can be used to electrically couple the electrodes or electrode portions to each other. Such capacitors or other filtering elements can be selected to create a generally uniform heating profile along the entire length of the high-resolution tip electrode. As noted in greater detail herein, for any of the embodiments disclosed herein or variations thereof, the filtering element can include something other than a capacitor. For example, in some arrangements, the filtering element comprises a LC circuit (e.g., a resonant circuit, a tank circuit, a tuned circuit, etc.). Such embodiments can be configured to permit simultaneous application of RF energy and measurement of EGM recordings.

[0101] As discussed above, the relatively small gap *G* between the adjacent electrodes or electrode portions **30A**, **30B** can be used to facilitate high-resolution mapping of the targeted tissue. For example, with continued reference to the schematic of FIG. 6, the separate electrodes or electrode portions **30A**, **30B** can be used to generate an electrogram that accurately reflects the localized electrical potential of the

tissue being treated. Thus, a physician or other practitioner using the treatment system can more accurately detect the impact of the energy delivery to the targeted tissue before, during and/or after a procedure. For example, the more accurate electrogram data that result from such configurations can enable the physician to detect any gaps or portions of the targeted anatomical region that was not properly ablated or otherwise treated. Specifically, the use of a high-resolution tip design can enable a cardiac electrophysiologist to more accurately evaluate the morphology of resulting electrograms, their amplitude and width and/or to determine pacing thresholds. In some embodiments, morphology, amplitude and pacing threshold are accepted and reliable EP markers that provide useful information about the outcome of an ablation or other heat treatment procedure.

[0102] According to some arrangements, the high-resolution-tip electrode embodiments disclosed herein are configured to provide localized high-resolution electrogram. For example, the electrogram that is obtained using a high-resolution-tip electrode, in accordance with embodiments disclosed herein, can provide electrogram data (e.g., graphical output) **400a**, **400b** as illustrated in FIG. 8. As depicted in FIG. 8, the localized electrograms **400a**, **400b** generated using the high-resolution-tip electrode embodiments disclosed herein include an amplitude **A1**, **A2**.

[0103] With continued reference to FIG. 8, the amplitude of the electrograms **400a**, **400b** obtained using high-resolution-tip electrode systems can be used to determine whether targeted tissue adjacent the high-resolution-tip electrode has been adequately ablated or otherwise treated. For example, according to some embodiments, the amplitude **A1** of an electrogram **400a** in untreated tissue (e.g., tissue that has not been ablated or otherwise heated) is greater than the amplitude **A2** of an electrogram **400b** that has already been ablated or otherwise treated. In some embodiments, therefore, the amplitude of the electrogram can be measured to determine whether tissue has been treated. For example, the electrogram amplitude **A1** of untreated tissue in a subject can be recorded and used as a baseline. Future electrogram amplitude measurements can be obtained and compared against such a baseline amplitude in an effort to determine whether tissue has been ablated or otherwise treated to an adequate or desired degree.

[0104] In some embodiments, a comparison is made between such a baseline amplitude (**A1**) relative to an electrogram amplitude (**A2**) at a tissue location being tested or evaluated. A ratio of **A1** to **A2** can be used to provide a quantitative measure for assessing the likelihood that ablation has been completed. In some arrangements, if the ratio (i.e., **A1/A2**) is above a certain minimum threshold, then the user can be informed that the tissue where the **A2** amplitude was obtained has been properly ablated. For example, in some embodiments, adequate ablation or treatment can be confirmed when the **A1/A2** ratio is greater than 1.5 (e.g., 1.5-1.6, 1.6-1.7, 1.7-1.8, 1.8-1.9, 1.9-2.0, 2.0-2.5, 2.5-3.0, values between the foregoing, greater than 3, etc.). However, in other embodiments, confirmation of ablation can be obtained when the ratio of **A1/A2** is less than 1.5 (e.g., 1-1.1, 1.1-1.2, 1.2-1.3, 1.3-1.4, 1.4-1.5, values between the foregoing, etc.).

[0105] FIG. 9 illustrates one embodiment of an expandable system **500** comprising a plurality of mapping electrodes **520**. Such systems **500** can include one or more expandable members (e.g., struts, balloons, etc.) **510** that support the electrodes **520** and help place such electrodes in contact or oth-

erwise in close proximity to a subject tissue. For example, the depicted embodiment of a mapping system 500 comprises a generally spherical configuration when expanded. In some embodiments, such a system 500 is sized, shaped and/or otherwise configured to be positioned and expanded within a heart chamber (e.g., atrium, ventricle) of a subject. In some arrangements, the struts comprise sufficient resiliency, stability, flexibility and/or other properties to enable the expanded system 500 to conform or generally conform to the bodily cavity or other space (e.g., atrium) in which it is positioned. Although one representation of a commercially-available system is depicted in FIG. 9, such systems with mapping electrodes can include any other shape, size and/or configuration, depending on one or more factors and/or other considerations, such as, for example, the targeted tissue of the subject, the number of electrodes that are desired or necessary and/or the like. For example, in other embodiments, such systems can include more or fewer electrodes, a non-spherical shape (e.g., conical, cylindrical, irregular, etc.) and/or the like, as desired or required for a particular application or use.

[0106] Regardless of the exact design, configuration and/or other properties of a commercially-available mapping system that may be utilized, the electrodes included within the mapping system can vary, as desired or required. For example, in some embodiments, the electrodes 520 comprise unipolar or bipolar electrodes. In addition, the shape, size, configuration and/or other details of the electrodes 520 used in such systems 500 may vary, based on the specific system design.

[0107] According to some embodiments, such mapping systems 500 are utilized to help map a subject's cardiac chamber (e.g., atrium) during a cardiac fibrillation (e.g., atrial fibrillation) treatment. For example, in some instances, subjects that indicate for atrial fibrillation exhibit an atrial fibrillation rotor pattern in their atrium that is characteristic of the disease. In some arrangements, electrically mapping the signals being transmitted through a subject's atrium, and thus, more accurately determining a map of the corresponding atrial fibrillation rotor that is cause of the disease, can assist with the subject treatment of the subject. For example, in some embodiments, once the atrial fibrillation rotor is accurately mapped, a practitioner can more precisely treat the portions of the atrium that help treat the disease. This can provide several benefits to a subject, including more precise and accurate ablation that increases the likelihood of effective treatment, less trauma to the subject as area or volume of tissue that is ablated can be reduced and/or the like.

[0108] In some embodiments, however, commercially-available mapping systems 500, such as the one schematically illustrated in FIG. 9, have certain shortcomings. For example, depending on how the system is positioned within the targeted anatomical area and/or how the system is deployed, one or more regions of the targeted anatomical volume, space or other region may not be close to a mapping electrode 520. For example, in some embodiments, the splines or other expandable members 510 of a system are not evenly deployed. In other instances, such expandable members 510, for one or more reasons, may not even expand properly or may not expand as intended or expected. As a result, in some cases, mapping electrodes 520 do not properly contact the targeted tissue and/or may leave relatively large areas of tissue between them. Accordingly, under such circumstances, the ability of such systems 500 to accurately map a targeted region of the subject's anatomy may be negatively impacted.

[0109] Therefore, according to some embodiments, a high-resolution-tip electrode catheter system, identical or similar to the systems and devices disclosed herein, can be used as a roving or gap-filling system to create a more accurate and complete electrical map of the targeted anatomical area. Thus, in some embodiments, the system and related methods disclosed herein do not rely solely on the various electrodes of a multi-electrode system or device in order to obtain a map (e.g., three-dimensional map) of tissue being mapped (e.g., cardiac tissue). By way of example, as illustrated schematically in FIG. 10, one or more gaps between the mapping electrodes 520 of a separate mapping system 500 can be "filled" or otherwise addressed from a mapping perspective using the high-resolution capabilities of the high-resolution-tip design. Accordingly, as schematically illustrated in FIG. 10, a high-resolution-tip electrode system can be directed to locations 530 where additional mapping data are required or desired.

[0110] In some arrangements, a catheter in accordance with any of the high-resolution-tip embodiments disclosed herein (e.g., those illustrated and discussed herein with reference to FIGS. 1 to 7) can be manually or positioned in some intermediate regions (e.g., regions where a mapping system's electrodes were unable to reach or cover). Thus, by using the high-resolution-tip electrode system as a roving mapping system, more accurate and comprehensive electrical mapping can be accomplished. As a result, in some embodiments, such a roving system (e.g., a catheter comprising a high-resolution electrode) is adapted to obtain mapping data for intermediate tissue locations (e.g., tissue locations located between electrodes of an expandable mapping system or other multi-electrode system or device). As noted above, this can result in a more complete and accurate understanding of the subject's disease and how to more efficiently, safely and effectively treat it. Relatedly, the number of individual ablations (and thus, the total area or volume of tissue that will be ablated) can be advantageously reduced, thereby reducing the overall trauma to the subject, reducing and otherwise mitigating the likelihood of any negative side effects from a treatment procedure, reducing recovery time and/or providing one or more additional advantages or benefits.

[0111] FIG. 11 illustrates a schematic of a mapping system 600 configured to obtain tissue mapping data using at least two different devices. For example, in the illustrated embodiment, the system 600 comprises a first device or system (S1) 20 and a second system (S2) 500. According to some embodiments, the first system 20 includes a roving catheter (e.g., comprising a high-resolution-tip design) in accordance with the various configurations disclosed herein or variations thereof. Further, in some embodiments, the second device or system (S2) 500 comprises a plurality of mapping electrodes (e.g., an expandable, catheter-based mapping system that includes electrodes along different splines and/or other expandable members).

[0112] With continued reference to the schematic of FIG. 11, depending on the type of electrode(s) that are included in each of the first and second devices or systems 20, 500, the mapping system 600 can include one or more reference electrodes 50, 550. For example, such reference electrodes may be necessary to obtain the necessary mapping data if the electrodes are unipolar. Therefore, in some embodiments, reference electrodes are unnecessary and thus optional and/or not included. By way of example, reference electrodes 50, 550 may be unnecessary if the first and/or the second devices

or systems 20, 500 comprise bipolar electrodes (e.g., having a high-resolution-tip design). As discussed herein, in some embodiments, second device or system 500 can include a multi-electrode design that is configured to obtain a plurality of mapping data points at once. For example, second system 500 can include one or more expandable members (e.g., splines, struts, balloons, other inflatable members, other mechanically expandable members or features, etc.). In some embodiments, each such expandable member can include one or more electrodes (e.g., unipolar, bipolar, etc.) that are configured to contact a certain region of the targeted anatomical region (e.g., atrium, ventricle, etc.) upon expansion of the second system 500. Thus, the various electrodes included in the second system 500 can be used to simultaneously obtain several different mapping data points within the targeted anatomical structure of a subject.

[0113] However, as noted herein, it may be desirable and beneficial to obtain additional mapping data at locations of the targeted anatomical structure that are between the specially-preset or predetermined locations associated with each of the electrodes of the second device or system 500. In some instances, the second device or system 500 may not be able to cover the entire desired extent or surface coverage or border of the targeted anatomical structure due to anatomical constraints or size or other physical, structural or operational constraints of the second system 500, thereby preventing a complete mapping of the targeted anatomical structure using the second system 500 alone. Accordingly, in some embodiments, a roving system, such as, for example, a catheter comprising a high-resolution-tip design (e.g., such as the various catheter systems disclosed herein) can be used to obtain such intermediate or additional mapping data. The roving system may also be used to determine anatomic region or tissue borders (e.g., superior vena cava border and pulmonary vein tissue borders).

[0114] With continued reference to the schematic of FIG. 11, the first device or system 20 (e.g., a catheter-based high-resolution-tip system, another type of roving mapping system, etc.) can be operatively coupled to a first data acquisition device or subsystem 610. Likewise, the second device or system 500 (e.g., multi-electrode mapping system) can be operatively coupled to another data acquisition device or subsystem 612. As illustrated schematically in FIG. 11, each of the data acquisition devices or subsystems 610, 612 can be placed in data communication and/or otherwise operatively coupled to a processor or other control module 650. In some embodiments, the mapping system 600 further comprises an output device 670 (e.g., monitor, other display, a computing device, etc.) that is operatively coupled to the processor 650 and is configured to provide mapping data and/or other information to the user. For example, such an output device 670 can include a graphical and/or numerical representation of the mapping data 672 obtained by the first and second devices or systems 20, 500. The output device 670 can additionally provide cardiac signal data (e.g., ECG) and/or the like, as desired or required. In some embodiments, the output device 670 can further include a user input component (e.g., a keypad, keyboard, touchscreen, etc.) to permit the user to enter instructions, information, data and/or the like. Such a user input component 674 can be integrated into the output device 670, as would be the case if the output device 670 included a touchscreen. However, in other embodiments, the system 600 comprises a separate user input device that is operatively

coupled to the processor 650, the output device 670 and/or any other component of the system 600, as desired or required.

[0115] In some embodiments, regardless of the exact configuration of an enhanced mapping system, such as the one illustrated in FIG. 11 and described herein, the processor 650 of such a system 600 is adapted to combine mapping data from a multi-electrode mapping system with data from a roving system (e.g., a catheter having a high-resolution-tip electrode and/or another electrode design capable of mapping). The combined mapping data obtained by the two mapping devices or systems 20, 500 can be advantageously combined within the processor 650 to provide an enhanced (e.g., more accurate, more complete) 3D map. As discussed in greater detail herein (e.g., with reference to FIG. 14), the processor 650 of the system 600 can be adapted to "align" the data from the two different mapping devices or systems 20, 500 as part of creating the enhanced three-dimensional (3D) map.

[0116] As discussed above, the multi-electrode mapping device or system 500 and/or the roving device or system 20 can include one or more bipolar mapping electrodes (e.g., high-resolution-tip electrodes). Thus, in such configurations, the electrodes can be used to obtain mapping data without the use of a reference electrode. However, in some embodiments, the multi-electrode mapping device or system 500 and/or the roving device or system 20 can include one or more unipolar mapping electrodes. In such arrangements, the need exists for one or more reference electrodes in order to obtain the desired mapping data for those unipolar electrodes. Thus, in some embodiments, the mapping system 600 can include one or more reference electrodes. Such reference electrodes can be located external to the subject (e.g., an electrode secured to the subject's skin, such as, for example, a right leg electrode) and/or internal to the subject (e.g., within the subject's superior or inferior vena cava or other vessel), as desired or required.

[0117] FIG. 12 schematically illustrates one embodiment of an enhanced mapping system 600 that includes a mapping device or system 500 having a plurality of mapping electrodes and a roving device or system 20 (e.g., a catheter with a high-resolution-tip electrode configuration, a catheter with another type of unipolar or bipolar electrode for mapping, etc.). As schematically depicted in FIG. 11, each of the mapping devices or systems 20, 500 can be operatively coupled to a processor or control unit 650 that is configured to retrieve the mapping data obtained by each of the systems or devices 20, 500 and generate an enhanced 3D map or other output of the targeted anatomical region being mapped. In FIG. 12, the additional data points obtained by the roving mapping device or system (e.g., the catheter with a high-resolution-tip design) are illustrated as dots or points between the set electrode locations of the multi-electrode system or device 500. Thus, as noted in greater detail herein, a user can obtain additional mapping data points to create a more accurate and complete 3D map of the targeted anatomical region being mapped (e.g., the atrium, the ventricle, another region within or near the heart, another anatomical region altogether, etc.).

[0118] FIG. 13 illustrates one embodiment of an algorithm used by an enhanced mapping system (e.g., such as the configurations disclosed herein, including, without limitation, the system 600 of FIGS. 11 and 12) to create an enhanced 3D map of a targeted anatomical region being mapped. As depicted in FIG. 13, in some embodiments, data is collected

(block 710) from a multi-electrode device or system (e.g., the multi-electrode mapping device or system 500 of FIGS. 11 and 12). Further, the mapping system can collect data (block 714) from a high resolution catheter or other device or system (e.g., such as a catheter having a high-resolution-tip electrode or other high-resolution electrode design). In some embodiments, the data obtained from each of the mapping systems or devices 20, 500 is aligned or synchronized (block 718) by the system. Such a step can help normalize the mapping data so that the mapping data accurately reflect the state of the various tissue locations being mapped.

[0119] With continued reference to FIG. 13, the system can generate (block 722) an enhanced 3D map of the anatomical region being mapped. At block 726, such mapping data can optionally be provided to a display in order to visually or graphically provide information to the user regarding the tissue being mapped. Alternatively, the mapping data can be saved on a storage device for future processing and review. In some embodiments, the display is integrated with the system. Alternatively, however, the system can be configured to operatively couple to a separate display that is not provided or included with the system.

[0120] According to some embodiments, a mapping system can include one or more of the following components: a high-resolution mapping catheter (e.g., a roving catheter), a device having a plurality of mapping electrodes (e.g., configured to produce unipolar and/or bipolar signals), a generator or other energy delivery module, a processor (e.g., which can be included within a generator or other energy delivery module, another component of the system, etc.), a display for displaying mapping data (e.g., in the form of an enhanced three-dimensional map), a user input device and/or any other component. For example, in some embodiments, the system comprises only a generator, other energy delivery module and/or other component comprising a processor that is configured to receive data from two or more mapping devices (e.g., a multi-electrode device, a roving catheter device, etc.). In such embodiments, the processor can receive mapping data from each device and create an enhanced three-dimensional map of the targeted tissue.

[0121] In other embodiments, the mapping system comprises only high resolution mapping catheter that is configured to be used with a separate multi-electrode device. As discussed in greater detail herein, mapping data obtained using such a high resolution catheter can be provided to a processor. Such a processor can also be configured to receiving mapping data from a separate mapping system (e.g., a multi-electrode mapping system), and combine the mapping data from the two systems to create an enhanced three-dimensional map of the targeted area. In some embodiments, although it may not be provided with the system, the processor can be included as part of the high-resolution catheter or the multi-electrode mapping device or other separate mapping device. In yet other embodiments, the processor can be included as a stand-alone device or component that is not provided with either the mapping catheter or the multi-electrode (or other) mapping device. Thus, in such arrangements, a separate processor (e.g., positioned within a device) can be used to connect two different mapping systems. Such a processor can be configured to operatively couple to two or more different mapping devices and/or systems (e.g., via wired, wireless and/or other connections). The processor can receive mapping data from each of the mapping devices and/or systems and to generate an enhanced three dimensional map.

[0122] According to some embodiments, a mapping system comprises one or more of the following devices and/or components: a high resolution catheter, an expandable device including a plurality of mapping electrodes, separate data acquisition devices configured to receive data from the high-resolution catheter and a multi-electrode mapping device (e.g., expandable device with mapping electrodes), a data acquisition device configured to receive data from both the multi-electrode mapping device and a multi-electrode mapping device, a processor configured to receive the mapping data from one or more data acquisition devices and to process said data to create an enhanced map (e.g., a three-dimensional map of the targeted tissue), an integrated data acquisition device and processor configured to receive mapping data from both the high-resolution catheter and mapping electrodes from a separate expandable device and to process said data to create an enhanced map (e.g., a three-dimensional map of the targeted tissue), a display or other output configured to visually display data and/or graphics related to a map (e.g., a three-dimensional map) of the mapping data obtained and processed by the mapping system and/or one or more other components, devices and/or systems, as desired or required.

[0123] By way of example, in one embodiment, the mapping system comprises a high resolution catheter, an expandable device comprising a plurality of mapping electrodes, a data acquisition device configured to receive mapping data from both the high-resolution catheter and the mapping electrodes of expandable mapping device. In such configurations, the system can further include a processor configured to receive the mapping data from the data acquisition device and to process such (e.g., align the data) to generate an enhanced map (e.g., a three-dimensional map) of the tissue. In some embodiments, the system comprises (or is otherwise configured to operatively couple, e.g., via a wired or wireless connection) to a display or other output device.

[0124] In accordance with the specific embodiment described above, mapping data are acquired from various mapping electrodes of an expandable system (e.g., a basket) and from a roving catheter having a high-resolution electrode. The catheter can be selectively moved within one or more gaps located between the electrodes of the expandable system to create a more complete and comprehensive map. The mapping data from the two different devices can be acquired by a single device, component and/or system (e.g., a device or component associated with or part of the high-resolution electrode catheter, a device or component associated with or part of the multi-electrode device, etc.). Further, as described in at least some of embodiments disclosed herein, a separate processor (e.g., processor 650) can be used to obtain the mapping data of the high-resolution catheter and the mapping electrodes of an expandable system. Such a processor can receive the mapping data and integrate them (e.g., align them) in order to be able to produce an enhanced three-dimensional map of the targeted tissue.

[0125] In other embodiments, the same device, component and/or system that acquires the mapping data from the two different devices is also configured to process such data and create an enhanced map (e.g., a three-dimensional map) of the targeted tissue. Such a single data acquisition device and processor can be part of the expandable system, the system that comprises the high-resolution catheter or a separate device, component and/or a separate system altogether, as desired or required.

[0126] In yet other embodiments, each of the high-resolution catheter device and a multi-electrode mapping device comprises a separate data acquisition device (e.g., the system does not include a single data acquisition device that is configured to receive mapping data from two separate devices). In such embodiments, the data acquired from each of the data acquisition devices can be provided to a separate processor to process the data (e.g. integrate the data) and to produce an enhanced map (e.g., a three-dimensional map) of the tissue being mapped.

[0127] As represented graphically in FIG. 14 and discussed in greater detail herein, the processor (e.g., processor 650) of an enhanced mapping system (e.g., one that uses two different mapping devices or systems) may need to align or otherwise manipulate the data obtained by each of the mapping systems operatively coupled to the system. For example, in some embodiments, the data are aligned or synchronized by applying an adjustment associated with the R-waves of the various electrocardiograms 810, 820 generated by each of the mapping devices or systems. Alternatively, other cardiac fiducial points may be used, including those coming from other sensor types, such as cardiac pressure sensors. As illustrated in FIG. 14, for example, the - waves can be aligned (e.g., graphically represented by dashed lines 830) in the corresponding electrocardiograms 810, 820 in order for the data obtained by the two devices or systems to be adjusted, and for a corresponding 3D map that integrates the data to be accurate.

[0128] According to some embodiments, as and/or after an enhanced 3D map of the targeted anatomical region is obtained, the first device or system (e.g., the catheter with the high-resolution-tip electrode or another type of electrode or energy delivery member) can be used to selectively ablate certain portions of the tissue. For example, as discussed in greater detail herein with reference to FIGS. 15A and 15B, a roving catheter-based system can be used to accurately detect any rotors (e.g., that may be the result of atrial fibrillation or of other cardiac condition) or other features or conditions within a targeted region (e.g., atrium) of a subject and ablate one or more portions of the said region (e.g., to interrupt the rotors). In some embodiments, the first device or system can be used to confirm lesion maturation.

[0129] FIG. 15A illustrates one embodiment of a 3D tissue map 900a obtained using only a multi-electrode system. In the illustrated arrangement, the multi-electrode device or system comprises a total of 64 electrodes that, when expanded within a targeted anatomical structure of a subject (e.g., an atrium), are configured to contact, and thus obtain mapping data, along specific locations of such a targeted anatomical structure. However, in other embodiments, a multi-electrode device or system can include fewer or greater than 64 electrodes, as desired or required. As shown, the 3D rotor map is created using activation timing data (e.g., as illustrated in FIG. 15A). Other types of cardiac maps can be created as well, such as: cardiac activation maps, propagation velocity maps, voltage maps, etc.

[0130] As illustrated in the example 3D activation map of FIG. 15A, there exist relatively large gaps or spaces between adjacent electrodes of the multi-electrode device or system. As a result, the corresponding 3D map that is generated using only the multi-electrode mapping device or system may be inaccurate and/or incomplete. For example, in some embodiments, there may exist a rotor or other indicia of a cardiac arrhythmia (e.g., atrial fibrillation) or other condition that

may not be identified by the fixed-space electrodes of a multi-electrode mapping device or system.

[0131] By way of example, FIG. 15B illustrates a region 920 of the subject's anatomical space that has been mapped using a roving (e.g., catheter-based) device or system, in accordance with the various embodiments disclosed herein. Thus, when contrasted to the 3D map of FIG. 15A, the map of FIG. 15B provides additional mapping data between the set, fixed locations of the electrodes in a multi-electrode device or system. For example, such additional information can be obtained in a region 920 located generally between the various set point locations of the fixed electrodes 910 of the multi-electrode device or system. In some embodiments, such intermediate mapping data can detect a different representation of the status of the corresponding tissue. For example, whereas in FIG. 15A, the tissue located at location 920 is not capable of being specifically mapped, a catheter having a high-resolution-tip electrode (or some other embodiment of a roving mapping electrode) may be able to obtain specific data regarding that intermediate location 920. As a result, an intermediate region (e.g., having a relatively early activation) can be contrasted to data that was obtained by only using the multi-electrode device or system (as shown in FIG. 15A). Consequently, the enhanced mapping system could be used to detect the presence of a rotor 930 (e.g., wherein a region of the targeted anatomical region exhibits a localized area in which activation of said tissue forms a circular or repetitive pattern). Thus, the presence of a condition can be accurately identified, and subsequently treated, using embodiments of the enhanced mapping devices or systems disclosed herein. As enumerated above, the embodiments disclosed herein can be used to generate many types of enhanced cardiac maps, such as, without limitation: cardiac activation maps, cardiac activity propagation velocity maps, cardiac voltage maps and rotor maps. In accordance with several embodiments, the enhanced mapping system facilitates more focused, localized or concentrated ablation targets and/or may reduce the number of ablations required to treat various conditions.

[0132] FIG. 16 schematically illustrates a different embodiment 1000 a filtering element 1004 configured for use with any of the mapping devices and systems disclosed herein (e.g., a roving catheter system comprising a high-resolution tip). The schematically depicted arrangement comprises a filter circuit 1004 that permits for the simultaneous application of RF energy (e.g., during the application of energy to targeted tissue to heat or otherwise ablate such tissue) and measurement of EGM recordings (e.g., for high-resolution mapping). Thus, in some embodiments, a capacitor that is placed across two electrodes or electrode portions can be replaced by a filter circuit such as the one schematically depicted in FIG. 16. Any other type of filtering element that permits an electrode to deliver energy (e.g., RF energy) and to obtain high-resolution mapping data can be included in any of the embodiments disclosed herein or variations thereof.

[0133] With continued reference to FIG. 16, the filtering element 1004 can include a LC circuit. In some embodiments, such a LC circuit can be tuned and otherwise configured to resonate near the RF energy frequency (e.g. 460 kHz, 400-500 kHz, 440-480 kHz, frequencies between the foregoing values, etc.), such that the electrodes or electrode portions of a high-resolution catheter or other medical instrument or device 20 have a relatively low impedance between them at the RF energy frequency. The impedance of the filter circuit

increases dramatically at lower frequencies, such as the frequencies utilized for EGM recordings, thus allowing for the two electrodes to be disconnected from each other to allow an EGM signal to formulate across them. As shown in the arrangement of FIG. 16, the filtering element 1004 can include an EGM recorder 1010 that is operatively coupled to a filter 1012. In addition, the RF generator or other energy delivery module, RF can be operatively coupled to a RF return pad or similar member 1050.

[0134] According to some embodiments, in order to achieve a circuit that resonates near a targeted frequency (e.g., 460 kHz) and that provides a high impedance at EGM frequencies, inductor values of 0.7 uH to 1000 uH may be used. In some embodiments, the value of the capacitance can be 0.12 to 170 nF. In some configurations, the LC circuit of such a filtering element 1004 is tuned to resonate at approximately 460 kHz (e.g. 460 kHz, 400-500 kHz, 440-480 kHz, frequencies between the foregoing values, etc.) by maintaining the relationship between L and C values in accordance with the following formula:

$$C = \frac{1}{L \cdot (2 \cdot \pi \cdot f)^2}$$

[0135] In the formula provided above, C is the capacitance, L is the inductance, and f is the frequency. According to some embodiments, a nominal value for the LC circuit may be L=20 uH and C=6 nF. However, in other configurations, such values can vary, as desired or required for a particular application or design. One embodiment 1100 of impedance magnitude versus frequency response of such LC circuits is graphically illustrated in FIG. 17. As noted herein, such a LC circuit or alternative filtering element can be used in any of the high-resolution embodiments disclosed herein (e.g., in lieu of a capacitor or altering filtering element that permits for both the delivery of energy and the ability to perform high-resolution mapping).

[0136] According to some embodiments, due to the nature of the high-resolution-tip electrode systems that are used to create a more complete and comprehensive map of targeted tissue, in accordance with the various high-resolution-tip systems and devices disclosed herein, additional information regarding the position of the roving catheter (and thus, the intermediate mapping locations) can be obtained and provided to the user during a procedure. For example, given the high-resolution mapping capabilities of such catheters, information can be obtained regarding the nature, type and other details regarding the tissue that is adjacent the electrode. In addition, as noted above, the high-resolution-tip embodiments disclosed herein can help determine whether a specific tissue region has been adequately ablated (e.g., see the disclosure above with reference to FIG. 8).

[0137] In some embodiments, any of the high-resolution-tip electrode devices or systems disclosed herein can be used as stand-alone mapping systems to accurately assess the condition of a subject's targeted anatomical region, even with the use of a separate mapping system (e.g., such as the one schematically illustrated in FIG. 9). For example, a user can move a high-resolution-tip electrode catheter or other medical instrument to various locations within a subject's anatomy to generate a detailed, accurate and complete electrical map, as desired or required.

[0138] As a result of the high-resolution mapping capabilities of the various high-resolution-tip electrode catheter devices and systems disclosed herein, an accurate map of the subject's targeted anatomical space or other region can be obtained. In addition, in view of the fact that such systems are also configured to advantageously ablate tissue, a more efficient and accurate treatment procedure can be attained. For example, in embodiments where one of the high-resolution-tip electrodes devices or systems disclosed herein is being used to map a subject's anatomy (e.g., atrium), either with or without the use of a separate (e.g., commercially-available mapping system), such a high-resolution-tip device or system can be used to also ablate tissue. This can facilitate and improve the execution of a treatment procedure. For example, the ability to use a single device to both map and ablate tissue permits a user to more expeditiously perform an overall assessment and treatment of a subject. In addition, the ability to create a more comprehensive map of the subject's tissue, allows a user to perform a subject treatment procedure with greater accuracy and precision. As discussed, this can help reduce the overall (and sometimes unnecessary) trauma to the subject, improve recovery and provide for better and effective treatment of the subject's disease. In addition, as noted above, the ability of the user to determine whether tissue has already been ablated or otherwise treated to a sufficient level can further improve the efficacy, efficiency and/or safety of a procedure.

[0139] In some embodiments, the system comprises various features that are present as single features (as opposed to multiple features). For example, in one embodiment, the system includes a single roving catheter that is configured to obtain high-resolution mapping of tissue and a single separate mapping device or system that includes mapping electrodes for mapping tissue of the subject. The separate mapping device or system can include an at least one expandable member, wherein at least some of the plurality of mapping electrodes of the separate mapping device or system are positioned along the expandable member. The roving catheter is configured to obtain mapping data in tissue regions not adequately covered by the separate mapping device or system. The system can include a single data acquisition device for receiving mapping data from the roving catheter and/or the separate mapping device or system. The system can further include a single processor that is configured to generate a three-dimensional map using the mapping data received by the data acquisition device. Thus, in some embodiments, the system does not require separate processors to receive and process mapping data that are received from separate mapping devices or systems (e.g., a multi-electrode mapping system or device, a roving catheter having a high-resolution electrode, etc.). The roving catheter can include a split-tip electrode design and/or any other high-resolution configuration. The processor can be configured to selectively ablate tissue based on the mapping data obtained from the roving catheter and the separate mapping device or system.

[0140] According to some embodiments, the system consists essentially of a roving catheter that is configured to obtain high-resolution mapping of tissue, a separate mapping device or system that includes mapping electrodes for mapping tissue of the subject and a data acquisition device for receiving mapping data from the roving catheter and/or the separate mapping device or system. In some embodiments, the system consists essentially of roving catheter that is configured to obtain high-resolution mapping of tissue, a separate

mapping device or system that includes mapping electrodes for mapping tissue of the subject, a data acquisition device for receiving mapping data from the roving catheter and/or the separate mapping device or system and a processor that is configured to generate a three-dimensional map using the mapping data received by the data acquisition device.

[0141] In some embodiments, the system comprises various features that are present as single features (as opposed to multiple features). For example, in one embodiment, the system includes a single ablation catheter with a single energy delivery radiofrequency electrode and one or more temperature sensors (e.g., thermocouples) to help determine the temperature of tissue at a depth. The system may comprise an impedance transformation network. Multiple features or components are provided in alternate embodiments.

[0142] In some embodiments, the system comprises one or more of the following: means for tissue modulation (e.g., an ablation or other type of modulation catheter or delivery device), means for generating energy (e.g., a generator or other energy delivery module), means for connecting the means for generating energy to the means for tissue modulation (e.g., an interface or input/output connector or other coupling member), means for obtaining mapping data using a multi-electrode mapping system (e.g., an expandable system that engages various portions of targeted tissue), means for obtaining mapping data (e.g., high-resolution data) in areas of the tissue located between the electrodes of a multi-electrode mapping system, means for acquiring data (e.g., using one or more data acquisition devices) from the multi-electrode mapping device or system and/or a device comprising a high-resolution electrode assembly (e.g., a roving catheter), means for processing mapping data obtained from the means for acquiring data (e.g., using a processor) to, e.g., generate a three-dimensional map, etc.

[0143] Any methods described herein may be embodied in, and partially or fully automated via, software code modules executed by one or more processors or other computing devices. The methods may be executed on the computing devices in response to execution of software instructions or other executable code read from a tangible computer readable medium. A tangible computer readable medium is a data storage device that can store data that is readable by a computer system. Examples of computer readable mediums include read-only memory, random-access memory, other volatile or non-volatile memory devices, CD-ROMs, magnetic tape, flash drives, and optical data storage devices.

[0144] In addition, embodiments may be implemented as computer-executable instructions stored in one or more tangible computer storage media. As will be appreciated by a person of ordinary skill in the art, such computer-executable instructions stored in tangible computer storage media define specific functions to be performed by computer hardware such as computer processors. In general, in such an implementation, the computer-executable instructions are loaded into memory accessible by at least one computer processor. The at least one computer processor then executes the instructions, causing computer hardware to perform the specific functions defined by the computer-executable instructions. As will be appreciated by a person of ordinary skill in the art, computer execution of computer-executable instructions is equivalent to the performance of the same functions by electronic hardware that includes hardware circuits that are hardwired to perform the specific functions. As such, while embodiments illustrated herein are typically implemented as

some combination of computer hardware and computer-executable instructions, the embodiments illustrated herein could also be implemented as one or more electronic circuits hardwired to perform the specific functions illustrated herein.

[0145] The various systems, devices and/or related methods disclosed herein can be used to at least partially ablate and/or otherwise ablate, heat or otherwise thermally treat one or more portions of a subject's anatomy, including without limitation, cardiac tissue (e.g., myocardium, atrial tissue, ventricular tissue, valves, etc.), a bodily lumen (e.g., vein, artery, airway, esophagus or other digestive tract lumen, urethra and/or other urinary tract vessels or lumens, other lumens, etc.), sphincters, other organs, tumors and/or other growths, nerve tissue and/or any other portion of the anatomy. The selective ablation and/or other heating of such anatomical locations can be used to treat one or more diseases or conditions, including, for example, atrial fibrillation, mitral valve regurgitation, other cardiac diseases, asthma, chronic obstructive pulmonary disease (COPD), other pulmonary or respiratory diseases, including benign or cancerous lung nodules, hypertension, heart failure, denervation, renal failure, obesity, diabetes, gastroesophageal reflux disease (GERD), other gastroenterological disorders, other nerve-related disease, tumors or other growths, pain and/or any other disease, condition or ailment.

[0146] In any of the embodiments disclosed herein, one or more components, including a processor, computer-readable medium or other memory, controllers (for example, dials, switches, knobs, etc.), displays (for example, temperature displays, timers, etc.) and/or the like are incorporated into and/or coupled with (for example, reversibly or irreversibly) one or more modules of the generator, the irrigation system (for example, irrigant pump, reservoir, etc.) and/or any other portion of an ablation or other modulation system.

[0147] Although several embodiments and examples are disclosed herein, the present application extends beyond the specifically disclosed embodiments to other alternative embodiments and/or uses of the inventions and modifications and equivalents thereof. It is also contemplated that various combinations or subcombinations of the specific features and aspects of the embodiments may be made and still fall within the scope of the inventions. Accordingly, it should be understood that various features and aspects of the disclosed embodiments can be combine with or substituted for one another in order to form varying modes of the disclosed inventions. Thus, it is intended that the scope of the present inventions herein disclosed should not be limited by the particular disclosed embodiments described above, but should be determined only by a fair reading of the claims that follow.

[0148] While the embodiments disclosed herein are susceptible to various modifications, and alternative forms, specific examples thereof have been shown in the drawings and are herein described in detail. It should be understood, however, that the inventions are not to be limited to the particular forms or methods disclosed, but, to the contrary, the inventions are to cover all modifications, equivalents, and alternatives falling within the spirit and scope of the various embodiments described and the appended claims. Any methods disclosed herein need not be performed in the order recited. The methods disclosed herein include certain actions taken by a practitioner; however, they can also include any third-party instruction of those actions, either expressly or by implication. For example, actions such as "advancing a catheter" or "delivering energy to an ablation member" include

“instructing advancing a catheter” or “instructing delivering energy to an ablation member,” respectively. The ranges disclosed herein also encompass any and all overlap, sub-ranges, and combinations thereof. Language such as “up to,” “at least,” “greater than,” “less than,” “between,” and the like includes the number recited. Numbers preceded by a term such as “about” or “approximately” include the recited numbers. For example, “about 10 mm” includes “10 mm.” Terms or phrases preceded by a term such as “substantially” include the recited term or phrase. For example, “substantially parallel” includes “parallel.”

What is claimed is:

1. A device for high-resolution mapping and ablating targeted tissue of subject, comprising:

an elongate body comprising a proximal end and a distal end;

a first high-resolution electrode portion positioned on the elongate body;

at least a second electrode portion positioned adjacent the first electrode portion, the first and second electrode portions being configured to contact tissue of a subject and deliver radiofrequency energy sufficient to at least partially ablate the tissue; and

at least one electrically insulating gap positioned between the first electrode portion and the second electrode portion, the at least one electrically insulating gap comprising a gap width separating the first and second electrode portions;

wherein the device is configured to be positioned within targeted tissue of the subject to obtain high-resolution mapping data related to said tissue when ablative energy is not being delivered via the first and second electrode portions; and

wherein the device is used as a roving device in conjunction with a separate mapping device or system to provide mapping data in tissue regions not adequately covered by said separate mapping device or system, wherein the separate mapping device or system comprises a plurality of mapping electrodes.

2. The device of claim 1:

wherein the first electrode portion is configured to electrically couple to the second electrode portion using a filtering element, wherein the filtering element is configured to present a low impedance at a frequency used for delivering ablative energy via the first and second electrode portions;

wherein electrically separating the first and second electrode portions facilitates high-resolution mapping along a targeted anatomical area; and

wherein, based in part on the obtained mapping data, the device is configured to ablate one or more regions of the subject's targeted tissue once ablative energy is delivered via the first and said electrode portions.

3. The device of claim 1, wherein electrically separating the first and second electrode portions facilitates high-resolution mapping along a targeted anatomical area.

4. The device of claim 1, wherein the first electrode portion is configured to electrically couple to the second electrode portion using a filtering element, wherein the filtering element is configured to present a low impedance at a frequency used for delivering ablative energy via the first and second electrode portions.

5. The device of claim 4, wherein the filtering element is separate from the device.

6. The device of claim 4, wherein the filtering element is included on or within the elongate body.

7. The device of claim 4, wherein the filtering element is included on or within a proximal handle secured to the elongate body.

8. The device of claim 1, wherein, based in part on the obtained mapping data, the device is configured to ablate one or more regions of the subject's targeted tissue once ablative energy is delivered to the first and said electrode portions.

9. The device of claim 1, wherein the device is configured to determine whether tissue has been properly ablated.

10. The device of claim 9, wherein a determination of whether tissue has been properly ablated is determined by comparing the amplitude of an electrogram obtained using the first and second electrode portions to a baseline electrogram amplitude.

11. The device of claim 1, wherein the device is configured to operatively couple to a data acquisition device and a processor,

wherein the data acquisition device is configured to receive mapping data from the first and second electrode portions, wherein the data acquisition device is configured to couple to the separate mapping device or system and to receive mapping data from the separate mapping device or system; and

wherein the processor is configured to generate a three-dimensional map from the mapping data received from the catheter and the separate mapping device or system by the data acquisition device.

12. A device for high-resolution mapping and ablating targeted tissue of subject, comprising:

an elongate body comprising a proximal end and a distal end;

a high-resolution electrode positioned on the elongate body, wherein the high-resolution electrode is configured to at least partially contact tissue of a subject;

wherein the device is configured to be positioned within targeted tissue of the subject to obtain high-resolution mapping data related to said tissue;

wherein the device is used as a roving device in conjunction with a separate mapping device to provide mapping data in tissue regions not adequately covered by said separate mapping device, wherein the separate mapping device comprises a plurality of mapping electrodes; and

wherein the device is configured to be operatively coupled to a data acquisition device configured to receive mapping data from the high-resolution electrode, wherein the data acquisition device is configured to couple to a separate mapping device and to receive mapping data from the separate mapping device.

13. The device of claim 12, wherein the high-resolution electrode is configured to deliver radiofrequency energy, and wherein, based in part on the obtained mapping data, the device is configured to ablate one or more regions of the subject's targeted tissue once ablative energy is delivered to the high-resolution electrode.

14. The device of claim 12, wherein the device is configured to determine whether tissue has been properly ablated, wherein a determination of whether tissue has been properly ablated is determined by comparing the amplitude of an electrogram obtained using the high-resolution electrode to a baseline electrogram amplitude.

15. A method of enhancing a map of a targeted anatomical region, the method comprising:

receiving mapping data from a first mapping device or system, the first mapping device or system comprising a plurality of mapping electrodes;

receiving high-resolution mapping data from a second mapping device or system, the second mapping device or system being configured to be moved to locations between the plurality of mapping electrodes of the first mapping system to obtain said high-resolution mapping data;

wherein the second mapping device or system comprises a roving system that can be selectively positioned along a targeted anatomical region of a subject;

processing the mapping data obtained by the first and second mapping devices or systems using a processor;

wherein the second mapping device or system is configured to supplement and refine a map of the targeted anatomical region; and

creating an enhanced three-dimensional map using the processor with the data obtained by the first and second mapping devices or systems.

16. The method of claim **15**, further comprising displaying the enhanced three-dimensional map.

17. The method of claim **15**, further comprising aligning or synchronizing the data obtained from the plurality of mapping electrodes of the first mapping device or system and from the second mapping device or system.

18. The method of claim **15**, wherein the first mapping device or system comprises at least one expandable member, and wherein at least some of the mapping electrodes are located on the at least one expandable member.

19. The method of claim **15**, wherein the targeted anatomical region comprises cardiac tissue.

20. The method of claim **15**, wherein the three-dimensional map comprising at least one of an activation map, a propagation velocity map, a voltage map and a rotor map.

* * * * *

专利名称(译)	用于组织的高分辨率映射的系统和方法		
公开(公告)号	US20160278857A1	公开(公告)日	2016-09-29
申请号	US15/179891	申请日	2016-06-10
[标]申请(专利权)人(译)	高级心脏治疗学		
申请(专利权)人(译)	高级心脏治疗学, INC.		
当前申请(专利权)人(译)	高级心脏治疗学, INC.		
[标]发明人	PANESCU DORIN KOBlish JOSEF VINCENT JOHNSON JESSI E		
发明人	PANESCU, DORIN KOBlish, JOSEF VINCENT JOHNSON, JESSI E.		
IPC分类号	A61B18/14 A61B5/00 A61B5/053		
CPC分类号	A61B18/1492 A61B5/0538 A61B2018/00642 A61B2017/00026 A61B2018/00577 A61B5/6858 A61B5/0422 A61B2017/320069 A61B2018/00083 A61B2018/0016 A61B2018/00267 A61B2018/00351 A61B2018/00357 A61B2018/0066 A61B2018/00732 A61B2018/00791 A61B2018/00839 A61B2018/00875 A61B2018/1467 A61B2218/002 A61B17/320068 A61B18/0218 A61B18/1815 A61B18/24 A61B2017/00044		
优先权	62/159898 2015-05-11 US 62/081710 2014-11-19 US		
其他公开文献	US9510905		
外部链接	Espacenet USPTO		

摘要(译)

根据一些实施方案, 方法和提高在地图上靶向解剖结构区域的系统包括从多个映射电极接收映射数据, 从一个高分辨率接收高分辨率测绘数据粗纱电极构造为移动到多个之间的位置测绘电极, 其中, 所述映射系统被配置来补充, 增强或缩小地图的靶向解剖结构区域的或直接创建使用处理器接收来自所述多个映射电极和从所获得的数据高分辨率三维地图的高分辨率粗纱电极。

