



US 20160081560A1

(19) **United States**

(12) **Patent Application Publication**
Hayter et al.

(10) **Pub. No.: US 2016/0081560 A1**
(43) **Pub. Date: Mar. 24, 2016**

(54) **METHOD AND APPARATUS FOR PROVIDING DATA PROCESSING AND CONTROL IN MEDICAL COMMUNICATION SYSTEM**

(60) Provisional application No. 60/911,869, filed on Apr. 14, 2007.

Publication Classification

(71) Applicant: **Abbott Diabetes Care Inc.**, Alameda, CA (US)

(51) **Int. Cl.**
A61B 5/01 (2006.01)
A61B 5/1473 (2006.01)
A61B 5/145 (2006.01)
A61B 5/00 (2006.01)

(72) Inventors: **Gary Alan Hayter**, Oakland, CA (US); **Mark Kent Sloan**, Redwood City, CA (US); **Martin J. Fennell**, Concord, CA (US)

(52) **U.S. Cl.**
CPC . *A61B 5/01* (2013.01); *A61B 5/002* (2013.01); *A61B 5/7278* (2013.01); *A61B 5/4839* (2013.01); *A61B 5/7435* (2013.01); *A61B 5/1473* (2013.01); *A61B 5/14532* (2013.01)

(73) Assignee: **Abbott Diabetes Care Inc.**, Alameda, CA (US)

(21) Appl. No.: **14/961,617**

(22) Filed: **Dec. 7, 2015**

(57) **ABSTRACT**

Related U.S. Application Data

(63) Continuation of application No. 12/102,839, filed on Apr. 14, 2008, now Pat. No. 9,204,827.

Methods and apparatus for providing data processing and control for use in a medical communication system are provided.

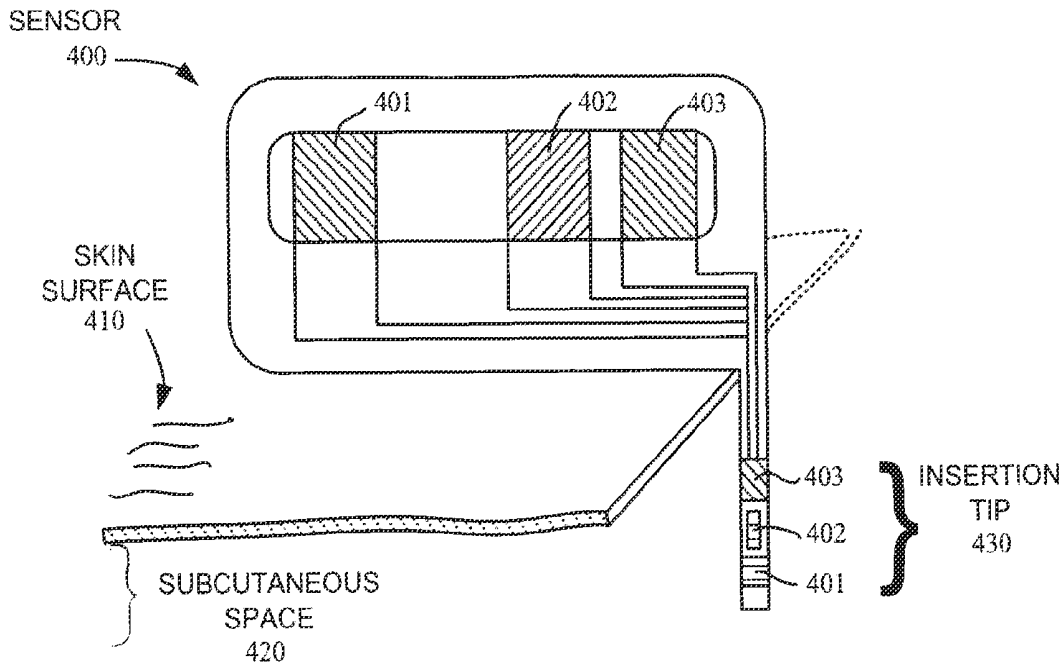

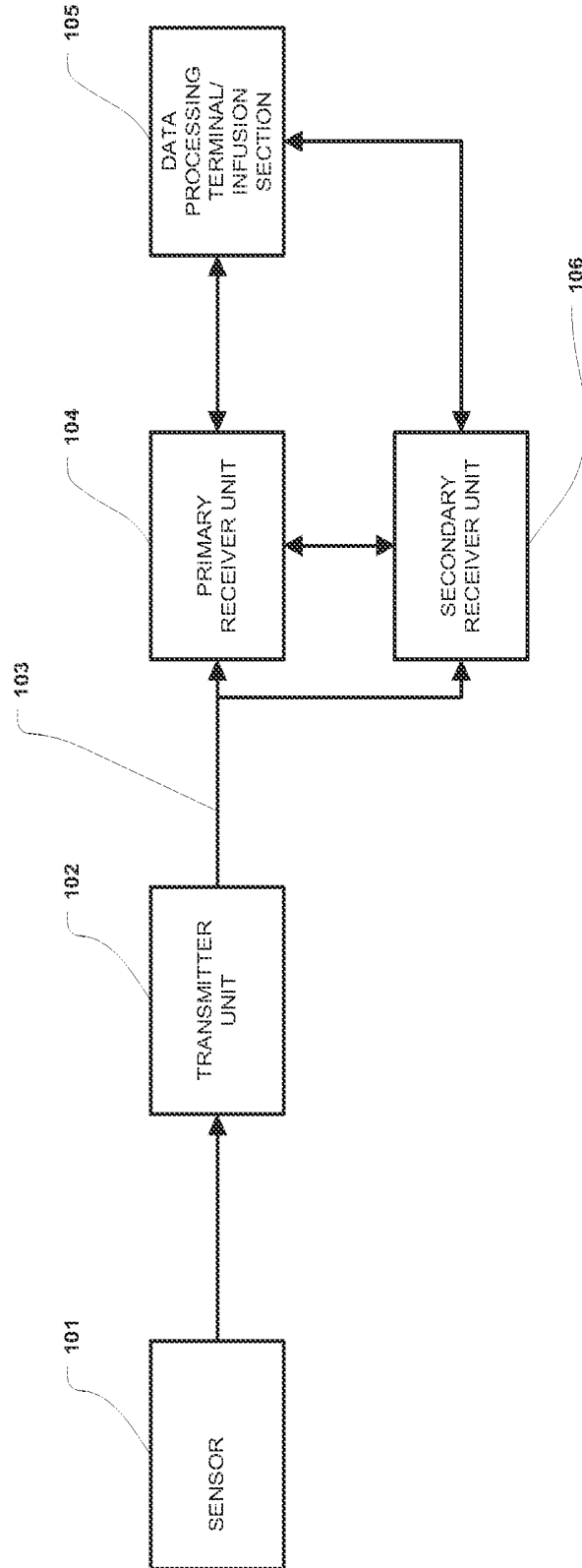

100

FIGURE 1

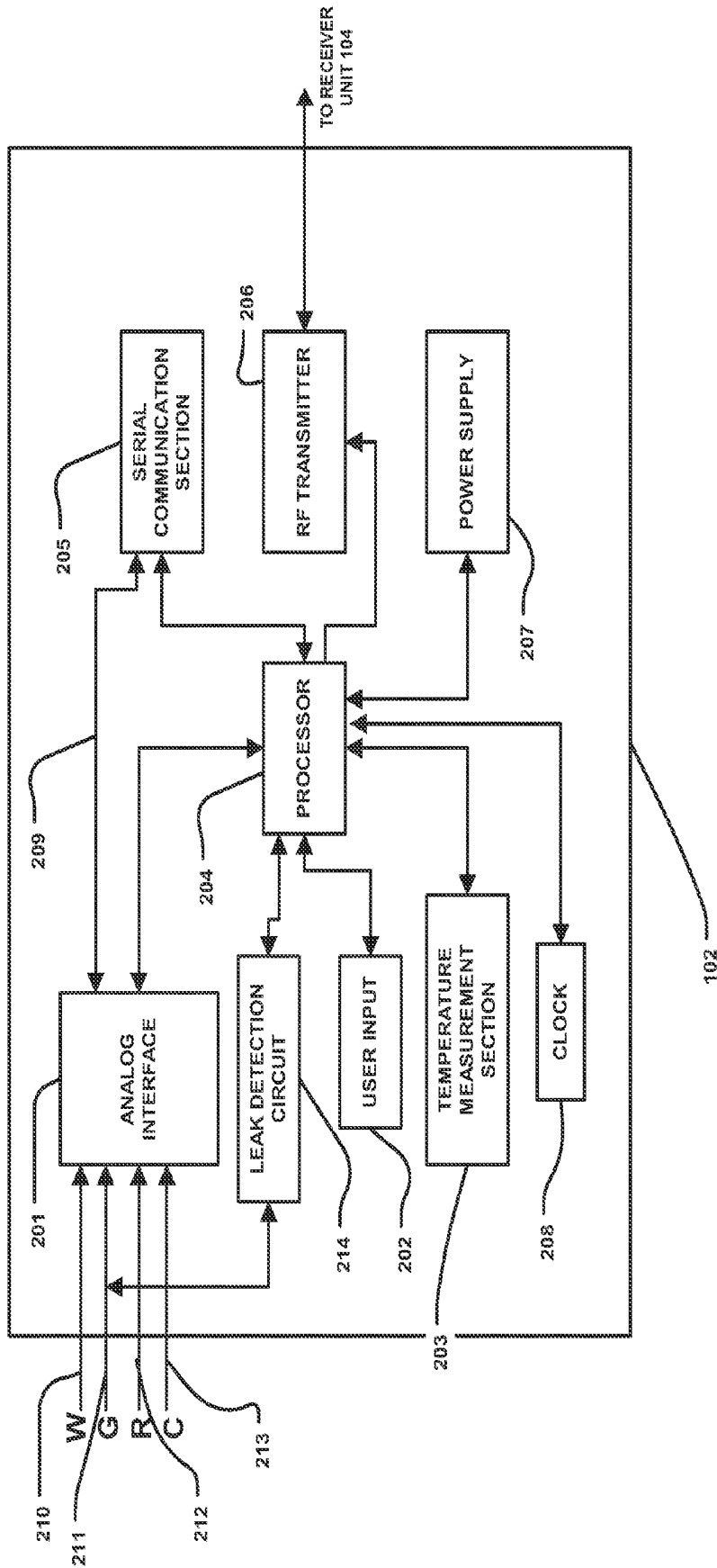

FIGURE 2

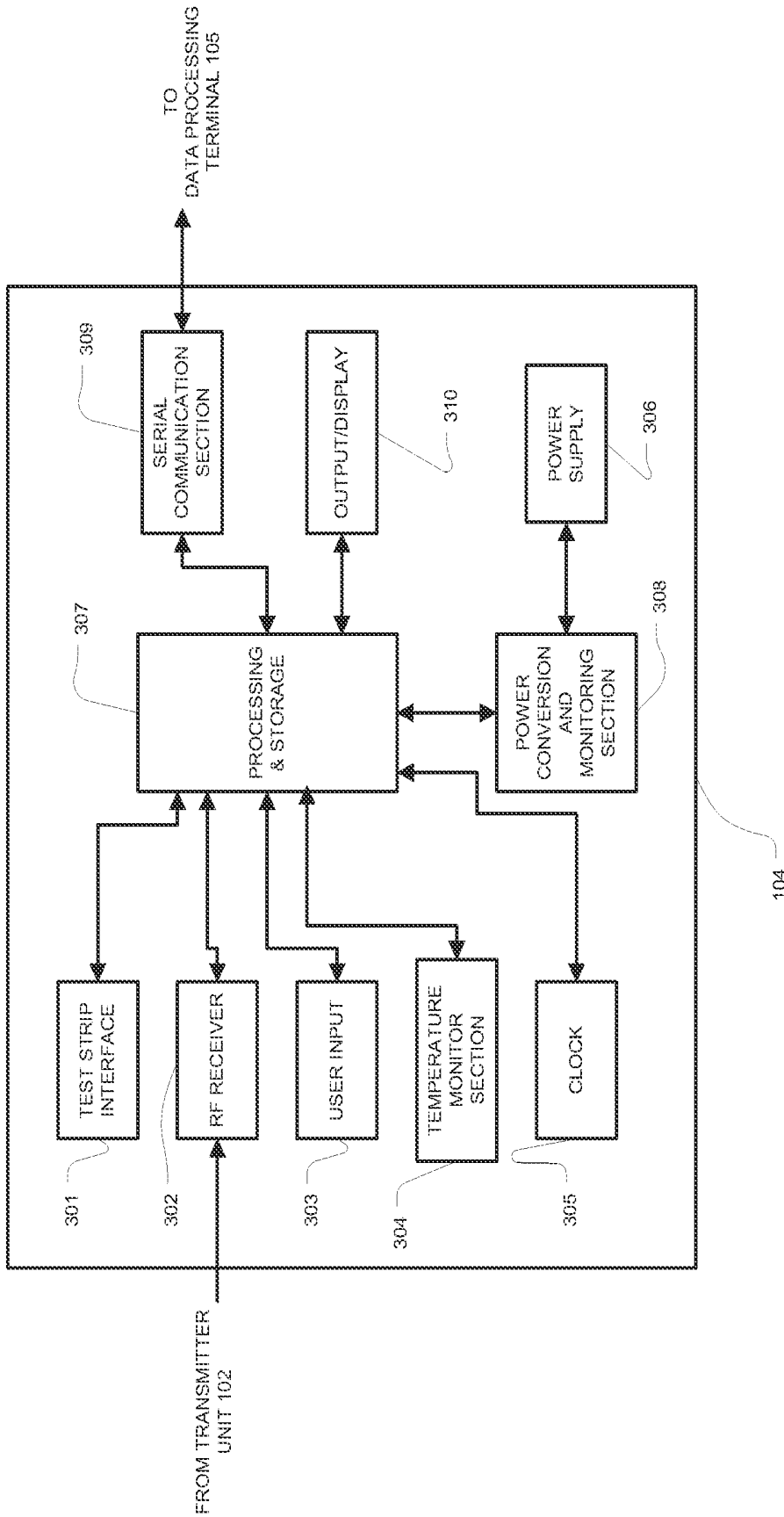

FIGURE 3

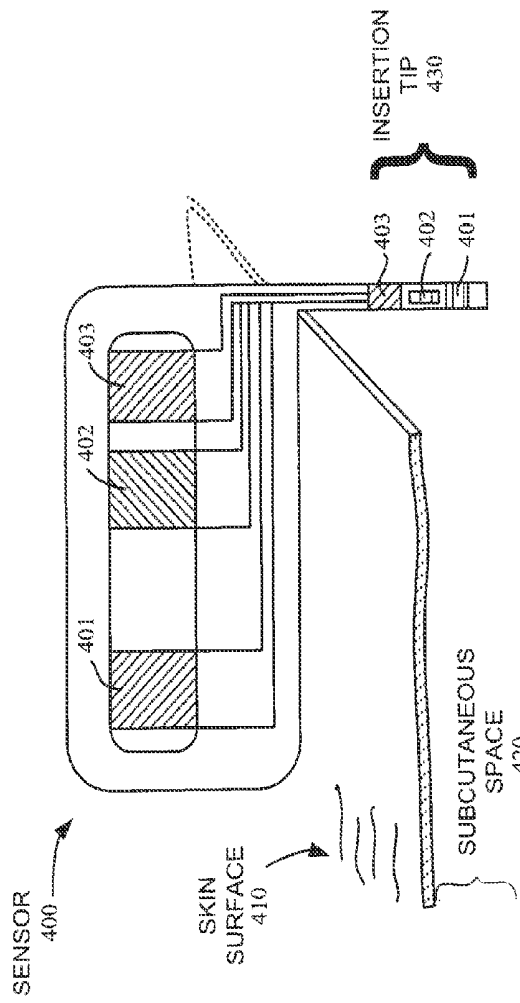

FIGURE 4A

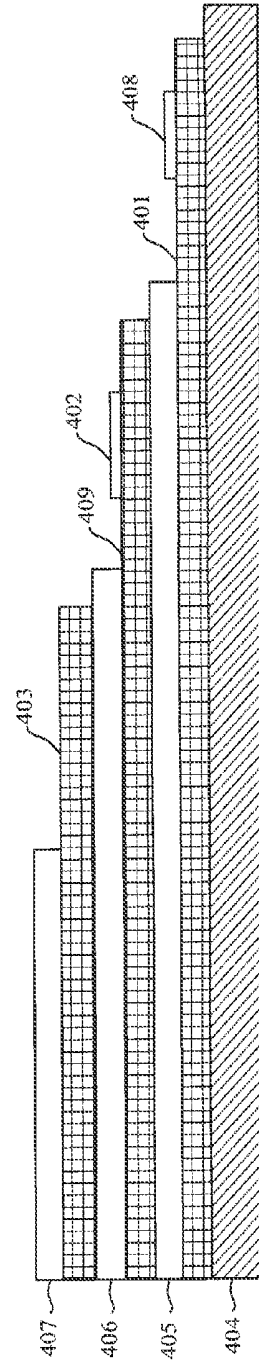

FIGURE 4B

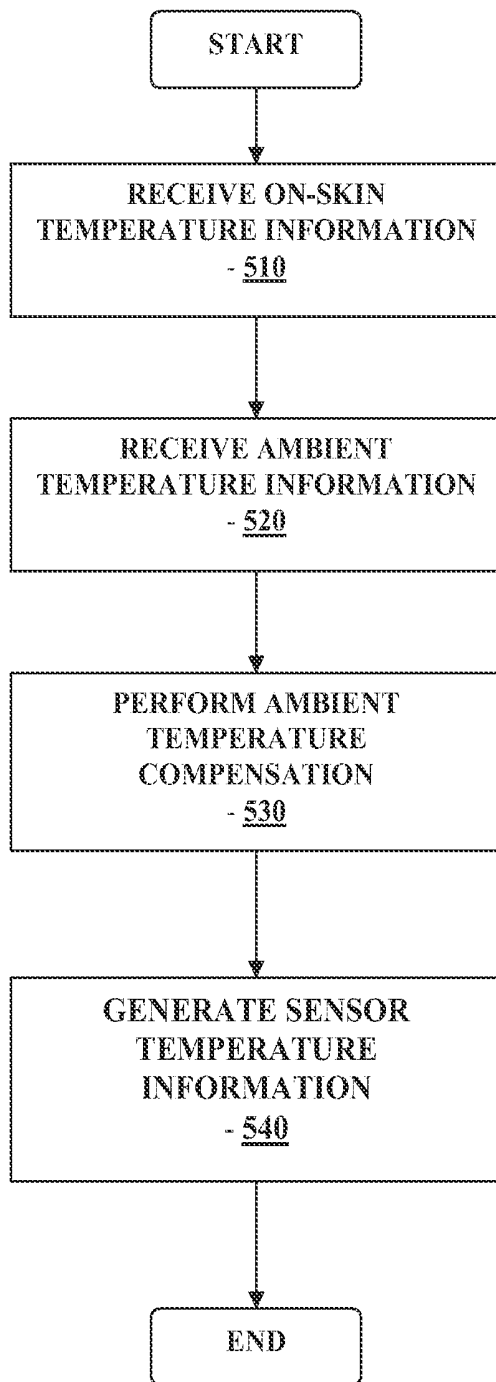

FIGURE 5

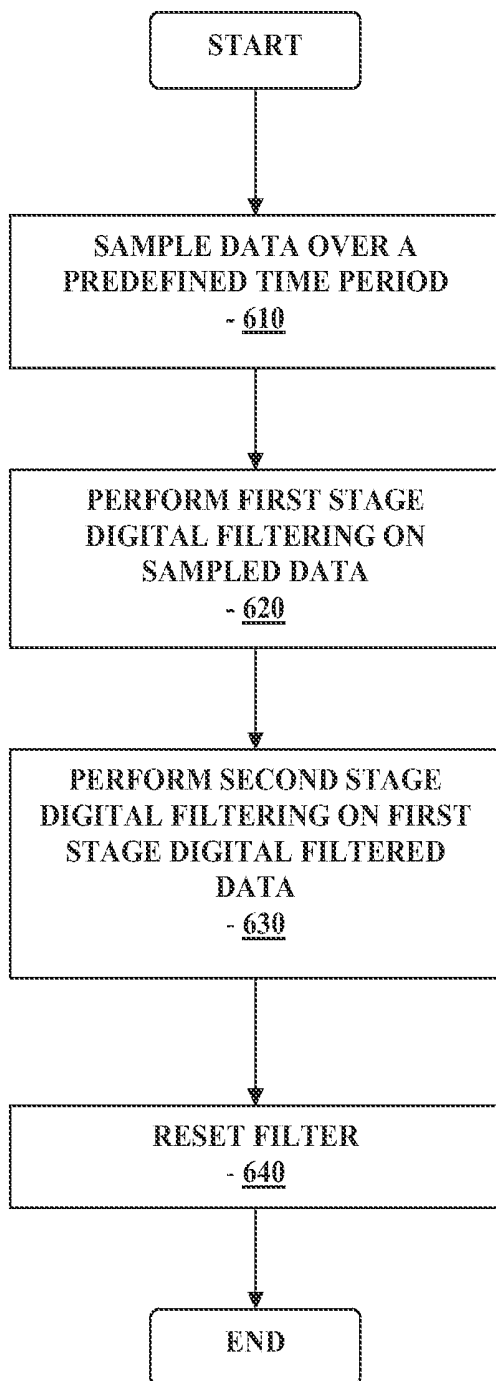

FIGURE 6

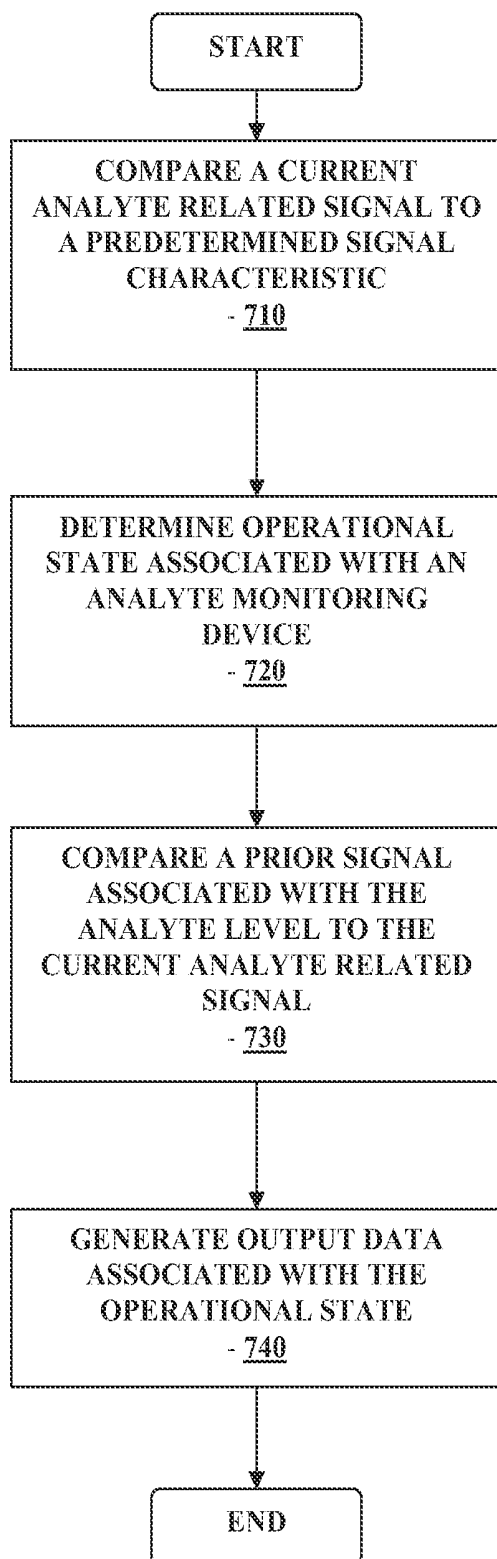

FIGURE 7

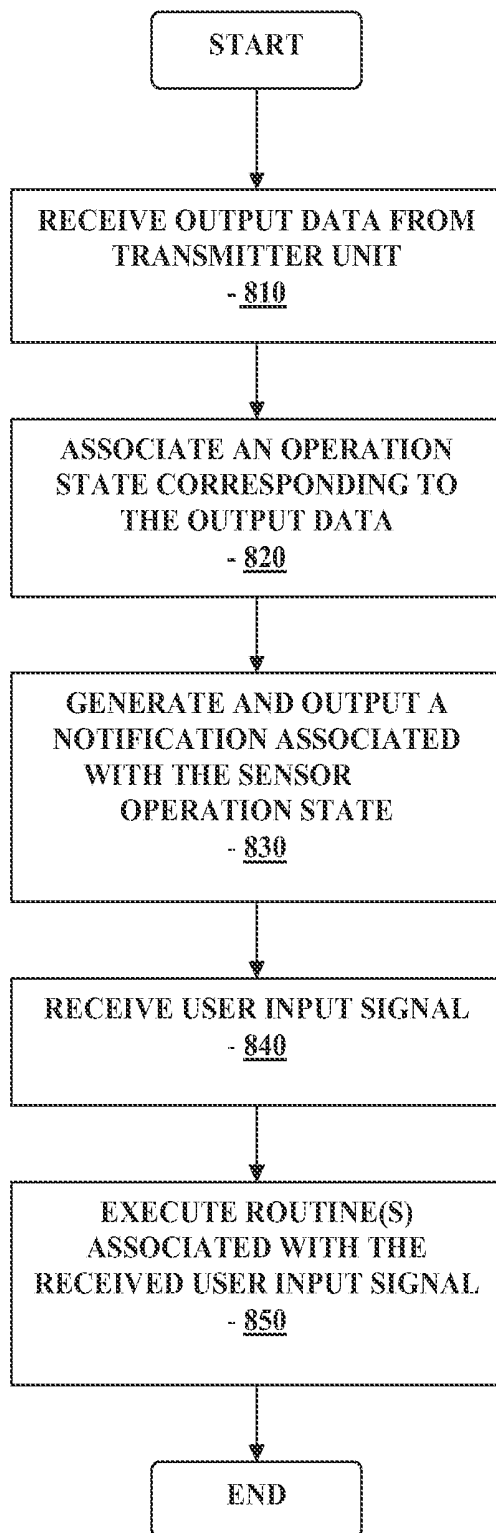

FIGURE 8

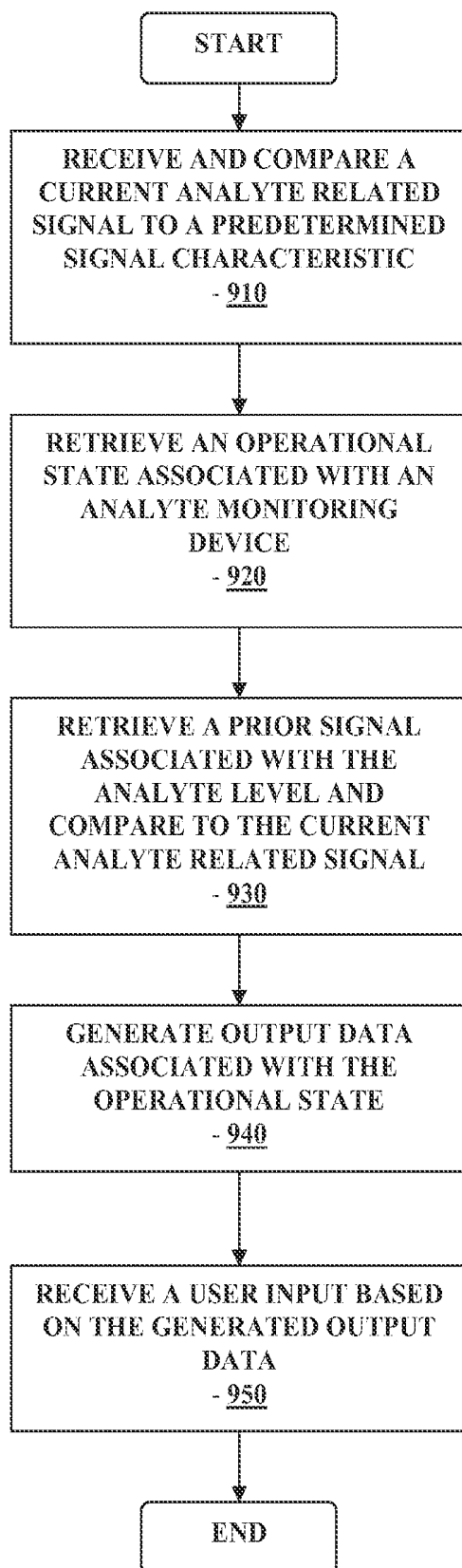

FIGURE 9

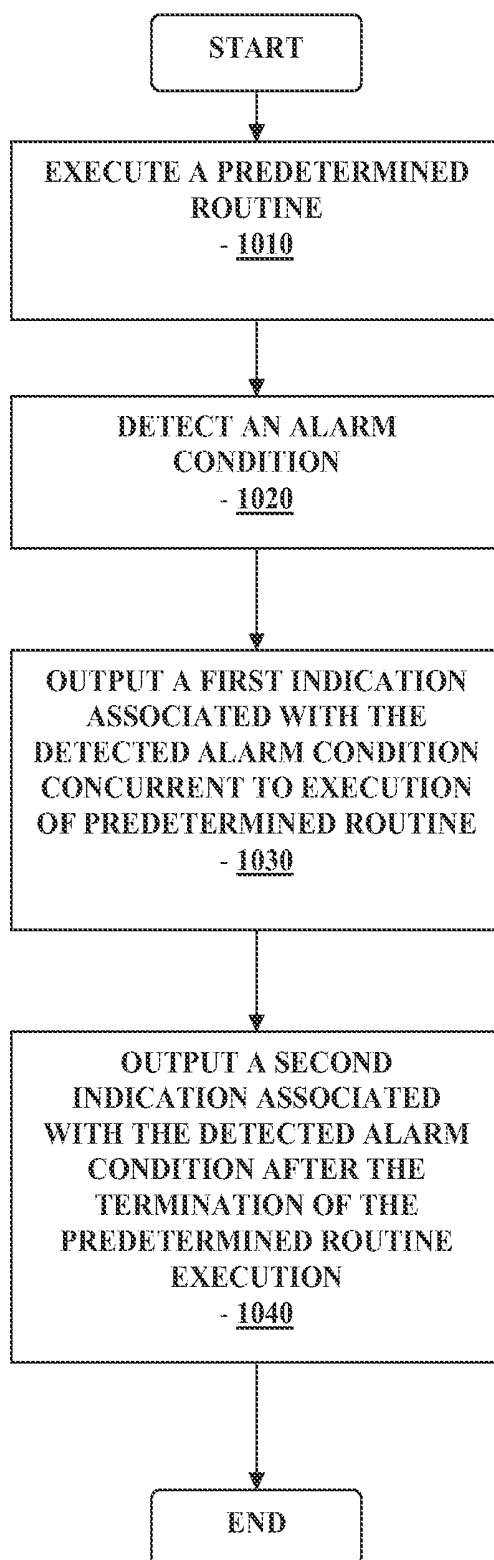

FIGURE 10

**METHOD AND APPARATUS FOR
PROVIDING DATA PROCESSING AND
CONTROL IN MEDICAL COMMUNICATION
SYSTEM**

RELATED APPLICATIONS

[0001] The present application is a continuation of U.S. patent application Ser. No. 12/102,839, filed Apr. 14, 2008, now U.S. Pat. No. 9,204,827, which claims priority under §35 U.S.C. 119(e) to U.S. Provisional Application No. 60/911,869 filed Apr. 14, 2007, entitled “Method and Apparatus for Providing Data Processing and Control in Medical Communication System”, and assigned to the Assignee of the present application, Abbott Diabetes Care Inc. of Alameda, Calif., the disclosure of which is incorporated herein by reference for all purposes.

BACKGROUND

[0002] Analyte, e.g., glucose monitoring systems including continuous and discrete monitoring systems generally include a small, lightweight battery powered and microprocessor controlled system which is configured to detect signals proportional to the corresponding measured glucose levels using an electrometer, and RF signals to transmit the collected data. One aspect of certain analyte monitoring systems include a transcutaneous or subcutaneous analyte sensor configuration which is, for example, partially mounted on the skin of a subject whose analyte level is to be monitored. The sensor cell may use a two or three-electrode (work, reference and counter electrodes) configuration driven by a controlled potential (potentiostat) analog circuit connected through a contact system.

[0003] The analyte sensor may be configured so that a portion thereof is placed under the skin of the patient so as to detect the analyte levels of the patient, and another portion of segment of the analyte sensor that is in communication with the transmitter unit. The transmitter unit is configured to transmit the analyte levels detected by the sensor over a wireless communication link such as an RF (radio frequency) communication link to a receiver/monitor unit. The receiver/monitor unit performs data analysis, among others on the received analyte levels to generate information pertaining to the monitored analyte levels. To provide flexibility in analyte sensor manufacturing and/or design, among others, tolerance of a larger range of the analyte sensor sensitivities for processing by the transmitter unit is desirable.

[0004] In view of the foregoing, it would be desirable to have a method and system for providing data processing and control for use in medical telemetry systems such as, for example, analyte monitoring systems.

SUMMARY OF THE INVENTION

[0005] In one embodiment, method and apparatus for detecting a first temperature related signal from a first source, detecting a second temperature related signal from a second source, the second source located at a predetermined distance from the first source, and estimating an analyte temperature related signal based on the first and second detected temperature signals, is disclosed.

[0006] These and other objects, features and advantages of the present invention will become more fully apparent from the following detailed description of the embodiments, the appended claims and the accompanying drawings.

BRIEF DESCRIPTION OF THE DRAWINGS

[0007] FIG. 1 illustrates a block diagram of a data monitoring and management system for practicing one or more embodiments of the present invention;

[0008] FIG. 2 is a block diagram of the transmitter unit of the data monitoring and management system shown in FIG. 1 in accordance with one embodiment of the present invention;

[0009] FIG. 3 is a block diagram of the receiver/monitor unit of the data monitoring and management system shown in FIG. 1 in accordance with one embodiment of the present invention;

[0010] FIGS. 4A-4B illustrate a perspective view and a cross sectional view, respectively of an analyte sensor in accordance with one embodiment of the present invention;

[0011] FIG. 5 is a flowchart illustrating ambient temperature compensation routine for determining on-skin temperature information in accordance with one embodiment of the present invention;

[0012] FIG. 6 is a flowchart illustrating digital anti-aliasing filtering routine in accordance with one embodiment of the present invention;

[0013] FIG. 7 is a flowchart illustrating actual or potential sensor insertion or removal detection routine in accordance with one embodiment of the present invention;

[0014] FIG. 8 is a flowchart illustrating receiver unit processing corresponding to the actual or potential sensor insertion or removal detection routine of FIG. 7 in accordance with one embodiment of the present invention;

[0015] FIG. 9 is a flowchart illustrating data processing corresponding to the actual or potential sensor insertion or removal detection routine in accordance with another embodiment of the present invention;

[0016] FIG. 10 is a flowchart illustrating a concurrent passive notification routine in the data receiver/monitor unit of the data monitoring and management system of FIG. 1 in accordance with one embodiment of the present invention.

DETAILED DESCRIPTION

[0017] As described in further detail below, in accordance with the various embodiments of the present invention, there is provided a method and apparatus for providing data processing and control for use in a medical telemetry system. In particular, within the scope of the present invention, there are provided method and system for providing data communication and control for use in a medical telemetry system such as, for example, a continuous glucose monitoring system.

[0018] FIG. 1 illustrates a data monitoring and management system such as, for example, analyte (e.g., glucose) monitoring system 100 in accordance with one embodiment of the present invention. The subject invention is further described primarily with respect to a glucose monitoring system for convenience and such description is in no way intended to limit the scope of the invention. It is to be understood that the analyte monitoring system may be configured to monitor a variety of analytes, e.g., lactate, and the like.

[0019] Analytes that may be monitored include, for example, acetyl choline, amylase, bilirubin, cholesterol, chorionic gonadotropin, creatine kinase (e.g., CK-MB), creatine, DNA, fructosamine, glucose, glutamine, growth hormones, hormones, ketones, lactate, peroxide, prostate-specific antigen, prothrombin, RNA, thyroid stimulating hormone, and troponin. The concentration of drugs, such as, for example, antibiotics (e.g., gentamicin, vancomycin, and

the like), digitoxin, digoxin, drugs of abuse, theophylline, and warfarin, may also be monitored.

[0020] The analyte monitoring system 100 includes a sensor 101, a transmitter unit 102 coupled to the sensor 101, and a primary receiver unit 104 which is configured to communicate with the transmitter unit 102 via a communication link 103. The primary receiver unit 104 may be further configured to transmit data to a data processing terminal 105 for evaluating the data received by the primary receiver unit 104. Moreover, the data processing terminal in one embodiment may be configured to receive data directly from the transmitter unit 102 via a communication link which may optionally be configured for bi-directional communication.

[0021] Also shown in FIG. 1 is a secondary receiver unit 106 which is operatively coupled to the communication link and configured to receive data transmitted from the transmitter unit 102. Moreover, as shown in the Figure, the secondary receiver unit 106 is configured to communicate with the primary receiver unit 104 as well as the data processing terminal 105. Indeed, the secondary receiver unit 106 may be configured for bi-directional wireless communication with each of the primary receiver unit 104 and the data processing terminal 105. As discussed in further detail below, in one embodiment of the present invention, the secondary receiver unit 106 may be configured to include a limited number of functions and features as compared with the primary receiver unit 104. As such, the secondary receiver unit 106 may be configured substantially in a smaller compact housing or embodied in a device such as a wrist watch, for example. Alternatively, the secondary receiver unit 106 may be configured with the same or substantially similar functionality as the primary receiver unit 104, and may be configured to be used in conjunction with a docking cradle unit for placement by bedside, for night time monitoring, and/or bi-directional communication device.

[0022] Only one sensor 101, transmitter unit 102, communication link 103, and data processing terminal 105 are shown in the embodiment of the analyte monitoring system 100 illustrated in FIG. 1. However, it will be appreciated by one of ordinary skill in the art that the analyte monitoring system 100 may include one or more sensor 101, transmitter unit 102, communication link 103, and data processing terminal 105. Moreover, within the scope of the present invention, the analyte monitoring system 100 may be a continuous monitoring system, or semi-continuous, or a discrete monitoring system. In a multi-component environment, each device is configured to be uniquely identified by each of the other devices in the system so that communication conflict is readily resolved between the various components within the analyte monitoring system 100.

[0023] In one embodiment of the present invention, the sensor 101 is physically positioned in or on the body of a user whose analyte level is being monitored. The sensor 101 may be configured to continuously sample the analyte level of the user and convert the sampled analyte level into a corresponding data signal for transmission by the transmitter unit 102. In one embodiment, the transmitter unit 102 is coupled to the sensor 101 so that both devices are positioned on the user's body, with at least a portion of the analyte sensor 101 positioned transcutaneously under the skin layer of the user. The transmitter unit 102 performs data processing such as filtering and encoding on data signals, each of which corresponds to a sampled analyte level of the user, for transmission to the primary receiver unit 104 via the communication link 103.

[0024] In one embodiment, the analyte monitoring system 100 is configured as a one-way RF communication path from the transmitter unit 102 to the primary receiver unit 104. In such embodiment, the transmitter unit 102 transmits the sampled data signals received from the sensor 101 without acknowledgement from the primary receiver unit 104 that the transmitted sampled data signals have been received. For example, the transmitter unit 102 may be configured to transmit the encoded sampled data signals at a fixed rate (e.g., at one minute intervals) after the completion of the initial power on procedure. Likewise, the primary receiver unit 104 may be configured to detect such transmitted encoded sampled data signals at predetermined time intervals. Alternatively, the analyte monitoring system 100 may be configured with a bi-directional RF (or otherwise) communication between the transmitter unit 102 and the primary receiver unit 104.

[0025] Additionally, in one aspect, the primary receiver unit 104 may include two sections. The first section is an analog interface section that is configured to communicate with the transmitter unit 102 via the communication link 103. In one embodiment, the analog interface section may include an RF receiver and an antenna for receiving and amplifying the data signals from the transmitter unit 102, which are thereafter, demodulated with a local oscillator and filtered through a band-pass filter. The second section of the primary receiver unit 104 is a data processing section which is configured to process the data signals received from the transmitter unit 102 such as by performing data decoding, error detection and correction, data clock generation, and data bit recovery.

[0026] In operation, upon completing the power-on procedure, the primary receiver unit 104 is configured to detect the presence of the transmitter unit 102 within its range based on, for example, the strength of the detected data signals received from the transmitter unit 102 or a predetermined transmitter identification information. Upon successful synchronization with the corresponding transmitter unit 102, the primary receiver unit 104 is configured to begin receiving from the transmitter unit 102 data signals corresponding to the user's detected analyte level. More specifically, the primary receiver unit 104 in one embodiment is configured to perform synchronized time hopping with the corresponding synchronized transmitter unit 102 via the communication link 103 to obtain the user's detected analyte level.

[0027] Referring again to FIG. 1, the data processing terminal 105 may include a personal computer, a portable computer such as a laptop or a handheld device (e.g., personal digital assistants (PDAs)), and the like, each of which may be configured for data communication with the receiver via a wired or a wireless connection. Additionally, the data processing terminal 105 may further be connected to a data network (not shown) for storing, retrieving and updating data corresponding to the detected analyte level of the user.

[0028] Within the scope of the present invention, the data processing terminal 105 may include an infusion device such as an insulin infusion pump or the like, which may be configured to administer insulin to patients, and which may be configured to communicate with the receiver unit 104 for receiving, among others, the measured analyte level. Alternatively, the receiver unit 104 may be configured to integrate an infusion device therein so that the receiver unit 104 is configured to administer insulin therapy to patients, for example, for administering and modifying basal profiles, as well as for

determining appropriate boluses for administration based on, among others, the detected analyte levels received from the transmitter unit 102.

[0029] Additionally, the transmitter unit 102, the primary receiver unit 104 and the data processing terminal 105 may each be configured for bi-directional wireless communication such that each of the transmitter unit 102, the primary receiver unit 104 and the data processing terminal 105 may be configured to communicate (that is, transmit data to and receive data from) with each other via a wireless communication link. More specifically, the data processing terminal 105 may in one embodiment be configured to receive data directly from the transmitter unit 102 via the communication link 103, where the communication link 103, as described above, may be configured for bi-directional communication.

[0030] In this embodiment, the data processing terminal 105 which may include an insulin pump, may be configured to receive the analyte signals from the transmitter unit 102, and thus, incorporate the functions of the receiver unit 104 including data processing for managing the patient's insulin therapy and analyte monitoring. In one embodiment, the communication link 103 may include one or more of an RF communication protocol, an infrared communication protocol, a Bluetooth® enabled communication protocol, an 802.11x wireless communication protocol, or an equivalent wireless communication protocol which would allow secure, wireless communication of several units (for example, per HIPAA requirements) while avoiding potential data collision and interference.

[0031] FIG. 2 is a block diagram of the transmitter unit 102 of the data monitoring and detection system shown in FIG. 1 in accordance with one embodiment of the present invention. Referring to the Figure, the transmitter unit 102 in one embodiment includes an analog interface 201 configured to communicate with the sensor 101 (FIG. 1), a user input 202, and a temperature detection section 203, each of which is operatively coupled to a transmitter processor 204 such as a central processing unit (CPU).

[0032] Further shown in FIG. 2 are a transmitter serial communication section 205 and an RF transmitter 206, each of which is also operatively coupled to the transmitter processor 204. Moreover, a power supply 207 such as a battery is also provided in the transmitter unit 102 to provide the necessary power for the transmitter unit 102. Additionally, as can be seen from the Figure, clock 208 is provided to, among others, supply real time information to the transmitter processor 204.

[0033] As can be seen from FIG. 2, the sensor 101 (FIG. 1) is provided four contacts, three of which are electrodes—work electrode (W) 210, guard contact (G) 211, reference electrode (R) 212, and counter electrode (C) 213, each operatively coupled to the analog interface 201 of the transmitter unit 102. In one embodiment, each of the work electrode (W) 210, guard contact (G) 211, reference electrode (R) 212, and counter electrode (C) 213 may be made using a conductive material that is either printed or etched, for example, such as carbon which may be printed, or metal foil (e.g., gold) which may be etched, or alternatively provided on a substrate material using laser or photolithography.

[0034] In one embodiment, a unidirectional input path is established from the sensor 101 (FIG. 1) and/or manufacturing and testing equipment to the analog interface 201 of the transmitter unit 102, while a unidirectional output is established from the output of the RF transmitter 206 of the trans-

mitter unit 102 for transmission to the primary receiver unit 104. In this manner, a data path is shown in FIG. 2 between the aforementioned unidirectional input and output via a dedicated link 209 from the analog interface 201 to serial communication section 205, thereafter to the processor 204, and then to the RF transmitter 206. As such, in one embodiment, via the data path described above, the transmitter unit 102 is configured to transmit to the primary receiver unit 104 (FIG. 1), via the communication link 103 (FIG. 1), processed and encoded data signals received from the sensor 101 (FIG. 1). Additionally, the unidirectional communication data path between the analog interface 201 and the RF transmitter 206 discussed above allows for the configuration of the transmitter unit 102 for operation upon completion of the manufacturing process as well as for direct communication for diagnostic and testing purposes.

[0035] As discussed above, the transmitter processor 204 is configured to transmit control signals to the various sections of the transmitter unit 102 during the operation of the transmitter unit 102. In one embodiment, the transmitter processor 204 also includes a memory (not shown) for storing data such as the identification information for the transmitter unit 102, as well as the data signals received from the sensor 101. The stored information may be retrieved and processed for transmission to the primary receiver unit 104 under the control of the transmitter processor 204. Furthermore, the power supply 207 may include a commercially available battery.

[0036] The transmitter unit 102 is also configured such that the power supply section 207 is capable of providing power to the transmitter for a minimum of about three months of continuous operation after having been stored for about eighteen months in a low-power (non-operating) mode. In one embodiment, this may be achieved by the transmitter processor 204 operating in low power modes in the non-operating state, for example, drawing no more than approximately 1 μ A of current. Indeed, in one embodiment, the final step during the manufacturing process of the transmitter unit 102 may place the transmitter unit 102 in the lower power, non-operating state (i.e., post-manufacture sleep mode). In this manner, the shelf life of the transmitter unit 102 may be significantly improved. Moreover, as shown in FIG. 2, while the power supply unit 207 is shown as coupled to the processor 204, and as such, the processor 204 is configured to provide control of the power supply unit 207, it should be noted that within the scope of the present invention, the power supply unit 207 is configured to provide the necessary power to each of the components of the transmitter unit 102 shown in FIG. 2.

[0037] Referring back to FIG. 2, the power supply section 207 of the transmitter unit 102 in one embodiment may include a rechargeable battery unit that may be recharged by a separate power supply recharging unit (for example, provided in the receiver unit 104) so that the transmitter unit 102 may be powered for a longer period of usage time. Moreover, in one embodiment, the transmitter unit 102 may be configured without a battery in the power supply section 207, in which case the transmitter unit 102 may be configured to receive power from an external power supply source (for example, a battery) as discussed in further detail below.

[0038] Referring yet again to FIG. 2, the temperature detection section 203 of the transmitter unit 102 is configured to monitor the temperature of the skin near the sensor insertion site. The temperature reading is used to adjust the analyte readings obtained from the analog interface 201. The RF

transmitter 206 of the transmitter unit 102 may be configured for operation in the frequency band of 315 MHz to 322 MHz, for example, in the United States. Further, in one embodiment, the RF transmitter 206 is configured to modulate the carrier frequency by performing Frequency Shift Keying and Manchester encoding. In one embodiment, the data transmission rate is 19,200 symbols per second, with a minimum transmission range for communication with the primary receiver unit 104.

[0039] Referring yet again to FIG. 2, also shown is a leak detection circuit 214 coupled to the guard contact (G) 211 and the processor 204 in the transmitter unit 102 of the data monitoring and management system 100. The leak detection circuit 214 in accordance with one embodiment of the present invention may be configured to detect leakage current in the sensor 101 to determine whether the measured sensor data are corrupt or whether the measured data from the sensor 101 is accurate.

[0040] FIG. 3 is a block diagram of the receiver/monitor unit of the data monitoring and management system shown in FIG. 1 in accordance with one embodiment of the present invention. Referring to FIG. 3, the primary receiver unit 104 includes a blood glucose test strip interface 301, an RF receiver 302, an input 303, a temperature detection section 304, and a clock 305, each of which is operatively coupled to a receiver processor 307. As can be further seen from the Figure, the primary receiver unit 104 also includes a power supply 306 operatively coupled to a power conversion and monitoring section 308. Further, the power conversion and monitoring section 308 is also coupled to the receiver processor 307. Moreover, also shown are a receiver serial communication section 309, and an output 310, each operatively coupled to the receiver processor 307.

[0041] In one embodiment, the test strip interface 301 includes a glucose level testing portion to receive a manual insertion of a glucose test strip, and thereby determine and display the glucose level of the test strip on the output 310 of the primary receiver unit 104. This manual testing of glucose can be used to calibrate sensor 101. The RF receiver 302 is configured to communicate, via the communication link 103 (FIG. 1) with the RF transmitter 206 of the transmitter unit 102, to receive encoded data signals from the transmitter unit 102 for, among others, signal mixing, demodulation, and other data processing. The input 303 of the primary receiver unit 104 is configured to allow the user to enter information into the primary receiver unit 104 as needed. In one aspect, the input 303 may include one or more keys of a keypad, a touch-sensitive screen, or a voice-activated input command unit. The temperature detection section 304 is configured to provide temperature information of the primary receiver unit 104 to the receiver processor 307, while the clock 305 provides, among others, real time information to the receiver processor 307.

[0042] Each of the various components of the primary receiver unit 104 shown in FIG. 3 is powered by the power supply 306 which, in one embodiment, includes a battery. Furthermore, the power conversion and monitoring section 308 is configured to monitor the power usage by the various components in the primary receiver unit 104 for effective power management and to alert the user, for example, in the event of power usage which renders the primary receiver unit 104 in sub-optimal operating conditions. An example of such sub-optimal operating condition may include, for example, operating the vibration output mode (as discussed below) for

a period of time thus substantially draining the power supply 306 while the processor 307 (thus, the primary receiver unit 104) is turned on. Moreover, the power conversion and monitoring section 308 may additionally be configured to include a reverse polarity protection circuit such as a field effect transistor (FET) configured as a battery activated switch.

[0043] The serial communication section 309 in the primary receiver unit 104 is configured to provide a bi-directional communication path from the testing and/or manufacturing equipment for, among others, initialization, testing, and configuration of the primary receiver unit 104. Serial communication section 104 can also be used to upload data to a computer, such as time-stamped blood glucose data. The communication link with an external device (not shown) can be made, for example, by cable, infrared (IR) or RF link. The output 310 of the primary receiver unit 104 is configured to provide, among others, a graphical user interface (GUI) such as a liquid crystal display (LCD) for displaying information. Additionally, the output 310 may also include an integrated speaker for outputting audible signals as well as to provide vibration output as commonly found in handheld electronic devices, such as mobile telephones presently available. In a further embodiment, the primary receiver unit 104 also includes an electro-luminescent lamp configured to provide backlighting to the output 310 for output visual display in dark ambient surroundings.

[0044] Referring back to FIG. 3, the primary receiver unit 104 in one embodiment may also include a storage section such as a programmable, non-volatile memory device as part of the processor 307, or provided separately in the primary receiver unit 104, operatively coupled to the processor 307. The processor 307 is further configured to perform Manchester decoding as well as error detection and correction upon the encoded data signals received from the transmitter unit 102 via the communication link 103.

[0045] In a further embodiment, the one or more of the transmitter unit 102, the primary receiver unit 104, secondary receiver unit 106, or the data processing terminal/infusion section 105 may be configured to receive the blood glucose value wirelessly over a communication link from, for example, a glucose meter. In still a further embodiment, the user or patient manipulating or using the analyte monitoring system 100 (FIG. 1) may manually input the blood glucose value using, for example, a user interface (for example, a keyboard, keypad, and the like) incorporated in the one or more of the transmitter unit 102, the primary receiver unit 104, secondary receiver unit 106, or the data processing terminal/infusion section 105.

[0046] Additional detailed description of the continuous analyte monitoring system, its various components including the functional descriptions of the transmitter are provided in U.S. Pat. No. 6,175,752 issued Jan. 16, 2001 entitled "Analyte Monitoring Device and Methods of Use", and in U.S. patent application Ser. No. 10/745,878 filed Dec. 26, 2003, now U.S. Pat. No. 7,811,231, entitled "Continuous Glucose Monitoring System and Methods of Use", each assigned to the Assignee of the present application, the disclosures of each of which are incorporated herein by reference for all purposes.

[0047] FIGS. 4A-4B illustrate a perspective view and a cross sectional view, respectively of an analyte sensor in accordance with one embodiment of the present invention. Referring to FIG. 4A, a perspective view of a sensor 400, the major portion of which is above the surface of the skin 410, with an insertion tip 430 penetrating through the skin and into

the subcutaneous space **420** in contact with the user's biofluid such as interstitial fluid. Contact portions of a working electrode **401**, a reference electrode **402**, and a counter electrode **403** can be seen on the portion of the sensor **400** situated above the skin surface **410**. Working electrode **401**, a reference electrode **402**, and a counter electrode **403** can be seen at the end of the insertion tip **430**.

[0048] Referring now to FIG. 4B, a cross sectional view of the sensor **400** in one embodiment is shown. In particular, it can be seen that the various electrodes of the sensor **400** as well as the substrate and the dielectric layers are provided in a stacked or layered configuration or construction. For example, as shown in FIG. 4B, in one aspect, the sensor **400** (such as the sensor **101** FIG. 1), includes a substrate layer **404**, and a first conducting layer **401** such as a carbon trace disposed on at least a portion of the substrate layer **404**, and which may comprise the working electrode. Also shown disposed on at least a portion of the first conducting layer **401** is a sensing layer **408**.

[0049] Referring back to FIG. 4B, a first insulation layer such as a first dielectric layer **405** is disposed or stacked on at least a portion of the first conducting layer **401**, and further, a second conducting layer **409** such as another carbon trace may be disposed or stacked on top of at least a portion of the first insulation layer (or dielectric layer) **405**. As shown in FIG. 4B, the second conducting layer **409** may comprise the reference electrode **402**, and in one aspect, may include a layer of silver/silver chloride (Ag/AgCl).

[0050] Referring still again to FIG. 4B, a second insulation layer **406** such as a dielectric layer in one embodiment may be disposed or stacked on at least a portion of the second conducting layer **409**. Further, a third conducting layer **403** which may include carbon trace and that may comprise the counter electrode **403**, may in one embodiment be disposed on at least a portion of the second insulation layer **406**. Finally, a third insulation layer **407** is disposed or stacked on at least a portion of the third conducting layer **403**. In this manner, the sensor **400** may be configured in a stacked or layered construction or configuration such that at least a portion of each of the conducting layers is separated by a respective insulation layer (for example, a dielectric layer).

[0051] Additionally, within the scope of the present invention, some or all of the electrodes **401**, **402**, **403** may be provided on the same side of the substrate layer **404** in a stacked construction as described above, or alternatively, may be provided in a co-planar manner such that each electrode is disposed on the same plane on the substrate layer **404**, however, with a dielectric material or insulation material disposed between the conducting layers/electrodes. Furthermore, in still another aspect of the present invention, the one or more conducting layers such as the electrodes **401**, **402**, **403**, may be disposed on opposing sides of the substrate layer **404**.

[0052] Referring back to the Figures, in one embodiment, the transmitter unit **102** (FIG. 1) is configured to detect the current signal from the sensor **101** (FIG. 1) and the skin temperature near the sensor **101**, which are preprocessed by, for example, by the transmitter processor **204** (FIG. 2) and transmitted to the receiver unit (for example, the primary receiver unit **104** (FIG. 1)) periodically at a predetermined time interval, such as for example, but not limited to, once per minute, once every two minutes, once every five minutes, or once every ten minutes. Additionally, the transmitter unit **102** may be configured to perform sensor insertion detection and data quality analysis, information pertaining to which are also

transmitted to the receiver unit **104** periodically at the predetermined time interval. In turn, the receiver unit **104** may be configured to perform, for example, skin temperature compensation as well as calibration of the sensor data received from the transmitter unit **102**.

[0053] For example, in one aspect, the transmitter unit **102** may be configured to oversample the sensor signal at a nominal rate of four samples per second, which allows the analyte anti-aliasing filter in the transmitter unit **102** to attenuate noise (for example, due to effects resulting from motion or movement of the sensor after placement) at frequencies above 2 Hz. More specifically, in one embodiment, the transmitter processor **204** may be configured to include a digital filter to reduce aliasing noise when decimating the four Hz sampled sensor data to once per minute samples for transmission to the receiver unit **104**. As discussed in further detail below, in one aspect, a two stage Kaiser FIR filter may be used to perform the digital filtering for anti-aliasing. While Kaiser FIR filter may be used for digital filtering of the sensor signals, within the scope of the present disclosure, other suitable filters may be used to filter the sensor signals.

[0054] In one aspect, the temperature measurement section **203** of the transmitter unit **102** may be configured to measure once per minute the on skin temperature near the analyte sensor at the end of the minute sampling cycle of the sensor signal. Within the scope of the present disclosure, different sample rates may be used which may include, for example, but not limited to, measuring the on skin temperature for each 30 second periods, each two minute periods, and the like. Additionally, as discussed above, the transmitter unit **102** may be configured to detect sensor insertion, sensor signal settling after sensor insertion, and sensor removal, in addition to detecting for sensor—transmitter system failure modes and sensor signal data integrity. Again, this information is transmitted periodically by the transmitter unit **102** to the receiver unit **104** along with the sampled sensor signals at the predetermined time intervals.

[0055] In a further aspect, the one or more temperature measurements may be obtained or performed at other times during the sampling cycle. For example, the one or more temperature measurements may be performed or obtained during the middle of the sampling cycle when the analyte related data are averaged or otherwise filtered over the cycle. Additionally, in particular embodiments, the one or more temperature measurements or information may be sampled at a faster rate than once per minute and averaged or otherwise filtered to generate a one minute temperature sample. Faster sampling rate may provide additional accuracy in the corresponding temperature measurement.

[0056] Referring again to the Figures, as the analyte sensor measurements are affected by the temperature of the tissue around the transcutaneously positioned sensor **101**, in one aspect, compensation of the temperature variations and affects on the sensor signals are provided for determining the corresponding glucose value. Moreover, the ambient temperature around the sensor **101** may affect the accuracy of the on skin temperature measurement and ultimately the glucose value determined from the sensor signals. Accordingly, in one aspect, a second temperature sensor is provided in the transmitter unit **102** away from the on skin temperature sensor (for example, physically away from the temperature measurement section **203** of the transmitter unit **102**), so as to provide compensation or correction of the on skin temperature measurements due to the ambient temperature effects. In this

manner, the accuracy of the estimated glucose value corresponding to the sensor signals may be attained.

[0057] In one aspect, the processor **204** of the transmitter unit **102** may be configured to include the second temperature sensor, which is located closer to the ambient thermal source within the transmitter unit **102**. In other embodiments, the second temperature sensor may be located at a different location within the transmitter unit **102** housing where the ambient temperature within the housing of the transmitter unit **102** may be accurately determined.

[0058] In a further aspect, each of the first and second temperature sensors may be configured to monitor and measure or detect on-skin temperature as well as ambient temperature. Additionally, within the scope of the present disclosure, two or more temperature sensors may be provided to monitor the on-skin temperature and the ambient temperature.

[0059] Referring now to FIG. 5, in one aspect, an ambient temperature compensation routine for determining the on-skin temperature level for use in the glucose estimation determination based on the signals received from the sensor **101** is shown. Referring to FIG. 5, for each sampled signal from the sensor **101**, a corresponding measured temperature information is received (**510**), for example, by the processor **204** from the temperature measurement section **203** (which may include, for example, a thermistor provided in the transmitter unit **102**). In addition, a second temperature measurement is obtained (**520**), for example, including a determination of the ambient temperature level using a second temperature sensor provided within the housing of the transmitter unit **102**.

[0060] In one aspect, based on a predetermined ratio of thermal resistances between the temperature measurement section **203** and the second temperature sensor (located, for example, within the processor **204** of the transmitter unit **102**), and between the temperature measurement section **203** and the skin layer on which the transmitter unit **102** is placed and coupled to the sensor **101**, ambient temperature compensation may be performed (**530**), to determine the corresponding ambient temperature compensated on skin temperature level (**540**). In one embodiment, the predetermined ratio of the thermal resistances may be approximately 0.2. However, within the scope of the present invention, this thermal resistance ratio may vary according to the design of the system, for example, based on the size of the transmitter unit **102** housing, the location of the second temperature sensor within the housing of the transmitter unit **102**, and the like.

[0061] With the ambient temperature compensated on-skin temperature information, the corresponding glucose value from the sampled analyte sensor signal may be determined.

[0062] Referring again to FIG. 2, the processor **204** of the transmitter unit **102** may include a digital anti-aliasing filter. Using analog anti-aliasing filters for a one minute measurement data sample rate would require a large capacitor in the transmitter unit **102** design, and which in turn impacts the size of the transmitter unit **102**. As such, in one aspect, the sensor signals may be oversampled (for example, at a rate of 4 times per second), and then the data is digitally decimated to derive a one-minute sample rate.

[0063] As discussed above, in one aspect, the digital anti-aliasing filter may be used to remove, for example, signal artifacts or otherwise undesirable aliasing effects on the sampled digital signals received from the analog interface **201** of the transmitter unit **102**. For example, in one aspect, the digital anti-aliasing filter may be used to accommodate

decimation of the sensor data from approximately four Hz samples to one-minute samples. In one aspect, a two stage FIR filter may be used for the digital anti-aliasing filter, and which includes improved response time, pass band and stop band properties.

[0064] Referring to FIG. 6, a routine for digital anti-aliasing filtering is shown in accordance with one embodiment. As shown, in one embodiment, at each predetermined time period such as every minute, the analog signal from the analog interface **201** corresponding to the monitored analyte level received from the sensor **101** (FIG. 1) is sampled (**610**). For example, at every minute, in one embodiment, the signal from the analog interface **201** is over-sampled at approximately 4 Hz. Thereafter, the first stage digital filtering on the over-sampled data is performed (**620**), where, for example, a $\frac{1}{2}$ down-sampling from 246 samples to 41 samples is performed, and the resulting 41 samples is further down-sampled at the second stage digital filtering (**630**) such that, for example, a $\frac{1}{41}$ down-sampling is performed from 41 samples (from the first stage digital filtering), to a single sample. Thereafter, the filter is reset (**640**), and the routine returns to the beginning for the next minute signal received from the analog interface **201**.

[0065] While the use of FIR filter, and in particular the use of Kaiser FIR filter, is within the scope of the present invention, other suitable filters, such as FIR filters with different weighting schemes or IIR filters, may be used.

[0066] Referring yet again to the Figures, the transmitter unit **102** may be configured in one embodiment to periodically perform data quality checks including error condition verifications and potential error condition detections, and also to transmit the relevant information related to one or more data quality, error condition or potential error condition detection to the receiver unit **104** with the transmission of the monitored sensor data. For example, in one aspect, a state machine may be used in conjunction with the transmitter unit **102** and which may be configured to be updated four times per second, the results of which are transmitted to the receiver unit **104** every minute.

[0067] In particular, using the state machine, the transmitter unit **102** may be configured to detect one or more states that may indicate when a sensor is inserted, when a sensor is removed from the user, and further, may additionally be configured to perform related data quality checks so as to determine when a new sensor has been inserted or transcutaneously positioned under the skin layer of the user and has settled in the inserted state such that the data transmitted from the transmitter unit **102** does not compromise the integrity of signal processing performed by the receiver unit **104** due to, for example, signal transients resulting from the sensor insertion.

[0068] That is, when the transmitter unit **102** detects low or no signal from the sensor **101**, which is followed by detected signals from the sensor **101** that is above a given signal, the processor **204** may be configured to identify such transition in the monitored signal levels and associate with a potential sensor insertion state. Alternatively, the transmitter unit **102** may be configured to detect the signal level above the another predetermined threshold level, which is followed by the detection of the signal level from the sensor **101** that falls below the predetermined threshold level. In such a case, the processor **204** may be configured to associate or identify such transition or condition in the monitored signal levels as a potential sensor removal state.

[0069] Accordingly, when either of potential sensor insertion state or potential sensor removal state is detected by the transmitter unit 102, this information is transmitted to the receiver unit 104, and in turn, the receiver unit 104 may be configured to prompt the user for confirmation of either of the detected potential sensor related state. In another aspect, the sensor insertion state or potential sensor removal state may be detected or determined by the receiver unit 104 based on one or more signals received from the transmitter unit 102. For example, similar to an alarm condition or a notification to the user, the receiver unit 104 may be configured to display a request or a prompt on the display or an output unit of the receiver unit 104 a text and/or other suitable notification message to inform the user to confirm the state of the sensor 101.

[0070] For example, the receiver unit 104 may be configured to display the following message: "New Sensor Inserted?" or a similar notification in the case where the receiver unit 104 receives one or more signals from the transmitter unit 102 associated with the detection of the signal level below the predetermined threshold level for the predefined period of time, followed by the detection of the signal level from the sensor 101 above another predetermined threshold level for another predefined period of time. Additionally, the receiver unit 104 may be configured to display the following message: "Sensor Removed?" or a similar notification in the case where the receiver unit 104 received one or more signals from the transmitter unit 102 associated with the detection of the signal level from the sensor 101 that is above the another predetermined threshold level for the another predefined period of time, which is followed by the detection of the signal level from the sensor 101 that falls below the predetermined threshold level for the predefined period of time.

[0071] Based on the user confirmation received, the receiver unit 104 may be further configured to execute or perform additional related processing and routines in response to the user confirmation or acknowledgement. For example, when the user confirms, using the user interface input/output mechanism of the receiver unit 104, for example, that a new sensor has been inserted, the receiver unit 104 may be configured to initiate new sensor insertion related routines including, such as, for example, sensor calibration routine including, for example, calibration timer, sensor expiration timer and the like. Alternatively, when the user confirms or it is determined that the sensor 101 is not properly positioned or otherwise removed from the insertion site, the receiver unit 104 may be accordingly configured to perform related functions such as, for example, stop displaying of the glucose values/levels, or deactivating the alarm monitoring conditions.

[0072] On the other hand, in response to the potential sensor insertion notification generated by the receiver unit 104, if the user confirms that no new sensor has been inserted, then the receiver unit 104 in one embodiment is configured to assume that the sensor 101 is in acceptable operational state, and continues to receive and process signals from the transmitter unit 102.

[0073] In this manner, in cases, for example, when there is momentary movement or temporary dislodging of the sensor 101 from the initially positioned transcutaneous state, or when one or more of the contact points between sensor 101 and the transmitter unit 102 are temporarily disconnected, but otherwise, the sensor 101 is operational and within its useful

life, the routine above provides an option to the user to maintain the usage of the sensor 101, and no replacing the sensor 101 prior to the expiration of its useful life. In this manner, in one aspect, false positive indications of sensor 101 failure may be identified and addressed.

[0074] For example, FIG. 7 is a flowchart illustrating actual or potential sensor insertion or removal detection routine in accordance with one embodiment of the present invention. Referring to the Figure, the current analyte related signal is first compared to a predetermined signal characteristic (710). In one aspect, the predetermined signal characteristic may include one of a signal level transition from below a first predetermined level (for example, but not limited to 18 ADC (analog to digital converter) counts) to above the first predetermined level, a signal level transition from above a second predetermined level (for example, but not limited to, 9 ADC counts) to below the second predetermined level, a transition from below a predetermined signal rate of change threshold to above the predetermined signal rate of change threshold, and a transition from above the predetermined signal rate of change threshold to below the predetermined signal rate of change threshold.

[0075] Referring back to the Figure, after comparing the current analyte related signal to the predetermined signal characteristic (710), a corresponding operational state associated with an analyte monitoring device is determined (720). Referring again to FIG. 7, after determining the corresponding operational state associated with the analyte monitoring device (720), the current analyte related signal may be compared to a prior signal associated with the analyte level (730) and an output data associated with the operational state is generated (740).

[0076] In this manner, in one aspect of the present invention, based on a transition state of the received analyte related signals, it may be possible to determine the state of the analyte sensor, and based on which, the user or the patient to confirm whether the analyte sensor is in the desired or proper position, has been temporarily dislocated, or otherwise, removed from the desired insertion site so as to require a new analyte sensor.

[0077] In this manner, in one aspect, when the monitored signal from the sensor 101 (FIG. 1) crosses a transition level (for example, from no or low signal level to a high signal level, or vice versa), the transmitter unit 102 may be configured to generate an appropriate output data associated with the sensor signal transition, for transmission to the receiver unit 104 (FIG. 1). Additionally, as discussed in further detail below, in another embodiment, the determination of whether the sensor 101 has crossed a transition level may be determined by the receiver/monitor unit 104/106 based, at least in part on the one or more signals received from the transmitter unit 102.

[0078] FIG. 8 is a flowchart illustrating receiver unit processing corresponding to the actual or potential sensor insertion or removal detection routine of FIG. 7 in accordance with one embodiment of the present invention. Referring now to FIG. 8, when the receiver unit 104 receives the generated output data from the transmitter unit 102 (810), a corresponding operation state is associated with the received output data (820), for example, related to the operational state of the sensor 101. Moreover, a notification associated with the sensor operation state is generated and output to the user on the display unit or any other suitable output segment of the receiver unit 104 (830). When a user input signal is received in response to the notification associated with the sensor state

operation state (840), the receiver unit 104 is configured to execute one or more routines associated with the received user input signal (850).

[0079] That is, as discussed above, in one aspect, if the user confirms that the sensor 101 has been removed, the receiver unit 104 may be configured to terminate or deactivate alarm monitoring and glucose displaying functions. On the other hand, if the user confirms that a new sensor 101 has been positioned or inserted into the user, then the receiver unit 104 may be configured to initiate or execute routines associated with the new sensor insertion, such as, for example, calibration procedures, establishing calibration timer, and establishing sensor expiration timer.

[0080] In a further embodiment, based on the detected or monitored signal transition, the receiver/monitor unit may be configured to determine the corresponding sensor state without relying upon the user input or confirmation signal associated with whether the sensor is dislocated or removed from the insertion site, or otherwise, operating properly.

[0081] FIG. 9 is a flowchart illustrating data processing corresponding to the actual or potential sensor insertion or removal detection routine in accordance with another embodiment of the present invention. Referring to FIG. 9, a current analyte related signal is received and compared to a predetermined signal characteristic (910). Thereafter, an operational state associated with an analyte monitoring device such as, for example, the sensor 101 (FIG. 1) is retrieved (920) from a storage unit or otherwise resident in, for example, a memory of the receiver/monitor unit. Additionally, a prior analyte related signal is also retrieved from the storage unit, and compared to the current analyte related signal received (930). An output data is generated which is associated with the operational state 940, and which at least in part is based on the one or more of the received current analyte related signal and the retrieved prior analyte related signal.

[0082] Referring again to FIG. 9, when the output data is generated, a corresponding user input command or signal is received in response to the generated output data (950), and which may include one or more of a confirmation, verification, or rejection of the operational state related to the analyte monitoring device.

[0083] FIG. 10 is a flowchart illustrating a concurrent passive notification routine in the data receiver/monitor unit of the data monitoring and management system of FIG. 1 in accordance with one embodiment of the present invention. Referring to FIG. 10, a predetermined routine is executed for a predetermined time period to completion (1010). During the execution of the predetermined routine, an alarm condition is detected (1020), and when the alarm or alert condition is detected, a first indication associated with the detected alarm or alert condition is output concurrent to the execution of the predetermined routine (1030).

[0084] That is, in one embodiment, when a predefined routine is being executed, and an alarm or alert condition is detected, a notification is provided to the user or patient associated with the detected alarm or alert condition, but which does not interrupt or otherwise disrupt the execution of the predefined routine. Referring back to FIG. 10, upon termination of the predetermined routine, another output or second indication associated with the detected alarm condition is output or displayed (1040).

[0085] More specifically, in one aspect, the user interface notification feature associated with the detected alarm condition is output to the user only upon the completion of an

ongoing routine which was in the process of being executed when the alarm condition is detected. As discussed above, when such alarm condition is detected during the execution of a predetermined routine, a temporary alarm notification such as, for example, a backlight indicator, a text output on the user interface display or any other suitable output indication may be provided to alert the user or the patient of the detected alarm condition substantially in real time, but which does not disrupt an ongoing routine.

[0086] Within the scope of the present invention, the ongoing routine or the predetermined routine being executed may include one or more of performing a finger stick blood glucose test (for example, for purposes of periodically calibrating the sensor 101), or any other processes that interface with the user interface, for example, on the receiver/monitor unit 104/106 (FIG. 1) including, but not limited to the configuration of device settings, review of historical data such as glucose data, alarms, events, entries in the data log, visual displays of data including graphs, lists, and plots, data communication management including RF communication administration, data transfer to the data processing terminal 105 (FIG. 1), or viewing one or more alarm conditions with a different priority in a preprogrammed or determined alarm or notification hierarchy structure.

[0087] In this manner, in one aspect of the present invention, the detection of one or more alarm conditions may be presented or notified to the user or the patient, without interrupting or disrupting an ongoing routine or process in, for example, the receiver/monitor unit 104/106 of the data monitoring and management system 100 (FIG. 1).

[0088] A method in accordance with one embodiment includes detecting a first temperature related signal from a first source, detecting a second temperature related signal from a second source, the second source located at a predetermined distance from the first source, and estimating an analyte temperature related signal based on the first and second detected temperature signals.

[0089] The first source in one aspect may be located substantially in close proximity to a transcutaneously positioned analyte sensor, and more specifically, in one embodiment, the first source may be located approximately 0.75 inches from the analyte sensor.

[0090] In a further embodiment, the analyte temperature related signal may be estimated based on a predetermined value associated with the detected first and second temperature related signals, where the predetermined value may include a ratio of thermal resistances associated with the first and second sources.

[0091] The method in a further aspect may include determining a glucose value based on the estimated analyte temperature related signal and a monitored analyte level.

[0092] The second temperature related signal in yet another aspect may be related to an ambient temperature source.

[0093] An apparatus in a further embodiment may include a housing, an analyte sensor coupled to the housing and transcutaneously positionable under a skin layer of a user, a first temperature detection unit coupled to the housing configured to detect a temperature associated with the analyte sensor, and a second temperature detection unit provided in the housing and configured to detect an ambient temperature.

[0094] The one or more of the first temperature detection unit or the second temperature detection unit may include one or more of a thermistor, a semiconductor temperature sensor, or a resistance temperature detector (RTD).

[0095] The apparatus in a further aspect may also include a processor, where at least a portion of the second temperature detection unit may be provided within the processor. In one aspect, the processor may be provided within same housing as the one or more first or second temperature detection units.

[0096] In another embodiment, the processor may be configured to receive the temperature associated with the analyte sensor, the ambient temperature, and an analyte related signal from the analyte sensor, and also, the processor may be configured to estimate an analyte temperature related signal based on the temperature associated with the analyte sensor, and the ambient temperature.

[0097] Also, the processor may be configured to determine a glucose value based on the estimated analyte temperature related signal and an analyte related signal from the analyte sensor.

[0098] In still another aspect, the analyte temperature related signal may be estimated based on a predetermined value associated with the detected temperature associated with the analyte sensor, and the ambient temperature, where the predetermined value may include a ratio of thermal resistances associated with the temperature associated with the analyte sensor, and the ambient temperature.

[0099] Alternatively, the predetermined value in still another aspect may be variable based on an error feedback signal associated with the monitored analyte level by the analyte sensor, where the error feedback signal may be associated with a difference between a blood glucose reference value and the analyte sensor signal.

[0100] The apparatus may also include a transmitter unit configured to transmit one or more signals associated with the detected temperature associated with the analyte sensor, detected ambient temperature, an analyte related signal from the analyte sensor, analyte temperature related signal based on the temperature associated with the analyte sensor, and the ambient temperature, or a glucose value based on the estimated analyte temperature related signal and the analyte related signal from the analyte sensor.

[0101] The transmitter unit may include an RF transmitter.

[0102] A system in accordance with still another embodiment may include a data receiver configured to receive a first temperature related signal from a first source, a second temperature related signal from a second source, the second source located at a predetermined distance from the first source, and a processor operatively coupled to the data receiver, and configured to estimate an analyte temperature related signal based on the first and second detected temperature signals.

[0103] An apparatus in accordance with a further embodiment includes a digital filter unit including a first filter stage and a second filter stage, the digital filter unit configured to receive a sampled signal, where the first filter stage is configured to filter the sampled signal based on a first predetermined filter characteristic to generate a first filter stage output signal, and further, where the second filter stage is configured to filter the first filter stage output signal based on a second predetermined filter characteristic to generate an output signal associated with a monitored analyte level.

[0104] The sampled signal may include an over-sampled signal at a frequency of approximately 4 Hz.

[0105] The digital filter unit may include one of a Finite Impulse Response (FIR) filter, or an Infinite Impulse Response (IIR) filter.

[0106] The first and the second filter stages may include a respective first and second down sampling filter characteristics.

[0107] Also, the one or more of the first and second filter stages may include down sampling the sampled signal or the first filter stage output signal, respectively, where the received sampled signal may be associated with the monitored analyte level of a user.

[0108] In another aspect, the digital filter unit may be configured to receive the sampled signal at a predetermined time interval.

[0109] The predetermined time interval in one aspect may include one of approximately 30 seconds, approximately one minute, approximately two minutes, approximately five minutes, or any other suitable time periods.

[0110] A method in accordance with yet another embodiment includes receiving a sampled signal associated with a monitored analyte level of a user, performing a first stage filtering based on the received sampled signal to generate a first stage filtered signal, performing a second stage filtering based on the generated first stage filtered signal, and generating a filtered sampled signal.

[0111] The sampled signal may include an over-sampled signal at a frequency of approximately 4 Hz, and also, where the first and the second stage filtering may include a respective first and second down sampling based on one or more filter characteristics.

[0112] The received sampled signal in one aspect may be periodically received at a predetermined time interval, where the predetermined time interval may include one of approximately 30 seconds, approximately one minute, approximately two minutes, or approximately five minutes.

[0113] A method in still another embodiment may include receiving a signal associated with an analyte level of a user, determining whether the received signal deviates from a predetermined signal characteristic, determining an operational state associated with an analyte monitoring device, comparing a prior signal associated with the analyte level of the user to the received signal, generating an output data associated with the operational state of the analyte monitoring device based on one or more of the received signal and the prior signal.

[0114] The predetermined signal characteristic in one embodiment may include a signal level transition from below a first predetermined level to above the first predetermined level, a signal level transition from above a second predetermined level to below the second predetermined threshold, a transition from below a predetermined signal rate of change threshold to above the predetermined signal rate of change threshold, or a transition from above the predetermined signal rate of change threshold to below the predetermined signal rate of change threshold.

[0115] In one aspect, the first predetermined level and the second predetermined level each may include one of approximately 9 ADC counts or approximately 18 ADC counts, or any other suitable signal levels or analog to digital converter (ADC) counts that respectively represent or correspond to a no sensor signal state, a sensor signal state, or the like.

[0116] The predetermine signal characteristic may include in one aspect, a transition from below a predetermined level to above and wherein the signal is maintained above the predetermined level for a predetermined period of time, where the predetermined period of time may include one of approxi-

mately 10 seconds, 30 seconds, or less than 30 seconds, or greater than 30 seconds, or any other suitable time periods.

[0117] In a further aspect, the operational state may include a no detected sensor state, or a sensor presence state.

[0118] The output data in one embodiment may include a user notification alert.

[0119] Further, the output data may include an indicator to start one or more processing timers associated with a respective one or more data processing routines, where the one or more processing timers may include a respective one of a calibration timer, or a sensor expiration timer.

[0120] The method may include receiving a user input data based on the output data, where the user input data may include a user confirmation of one of the change in operational state or no change in operational state.

[0121] The method may further include modifying the operational state, where the operational state may be modified based on one of the received user input data, or based on the generated output data.

[0122] The method may include presenting the output data, where presenting the output data may include one or more of visually presenting the output data, audibly presenting the output data, vibratorily presenting the output data, or one or more combinations thereof.

[0123] The analyte level may include glucose level of the user.

[0124] The operational state may include one of an analyte sensor removal state, an analyte sensor insertion state, an analyte sensor dislocation state, an analyte sensor insertion with an associated transient signal state, or an analyte sensor insertion with an associated stabilized signal state.

[0125] An apparatus in still yet another embodiment may include a data processing unit including a data processor configured to determine whether a received signal associated with an analyte level of a user deviates from a predetermined signal characteristic, determine an operational state associated with an analyte monitoring device, compare a prior signal associated with the analyte level of the user to the received signal, and generate an output data associated with the operational state of the analyte monitoring device based on one or more of the received signal or the prior signal.

[0126] The data processing unit may include a communication unit operatively coupled to the data processor and configured to communicate one or more of the received signal, the prior signal, and the output data associated the operational state of the analyte monitoring device.

[0127] The communication unit may include one of an RF transmitter, an RF receiver, an infrared data communication device, a Bluetooth® data communication device, or a Zig-bee® data communication device.

[0128] The data processing unit may include a storage unit operatively coupled to the data processor to store one or more of the received signal associated with the analyte level, the predetermined signal characteristic, the operational state associated with the analyte monitoring device, the prior signal associated with the analyte level of the user, or the output data associated with the operational state of the analyte monitoring device.

[0129] A method in accordance with still yet a further embodiment may include receiving a signal associated with an analyte level of a user, determining whether the received signal deviates from a predetermined signal characteristic, determining an operational state associated with an analyte monitoring device, comparing a prior signal associated with

the analyte level of the user to the received signal, presenting an output data associated with the operational state of the analyte monitoring device based at least in part on one or more of the received signal or the prior signal, and receiving a user input data based on the presented output data.

[0130] In still another aspect, the predetermined signal characteristic may include a signal level transition from below a first predetermined level to above the first predetermined level, a signal level transition from above a second predetermined level to below the second predetermined level, a transition from below a predetermined signal rate of change threshold to above the predetermined signal rate of change threshold, and a transition from above the predetermined signal rate of change threshold to below the predetermined signal rate of change threshold, and further, where the first predetermined level and the second predetermined level each may include one of approximately 9 ADC counts or approximately 18 ADC counts, or other predetermined ADC counts or signal levels.

[0131] The predetermine signal characteristic in another aspect may include a transition from below a predetermined level to above and wherein the signal is maintained above the predetermined level for a predetermined period of time which may include, for example, but not limited to, approximately 10 seconds, 30 seconds, or less than 30 seconds, or greater than 30 seconds.

[0132] Further, the operational state may include a no detected sensor state, or a sensor presence state.

[0133] Moreover, the output data may include a user notification alert.

[0134] The output data may include an indicator to start one or more processing timers associated with a respective one or more data processing routines, where the one or more processing timers may include a respective one of a calibration timer, or a sensor expiration timer.

[0135] In another aspect, the user input data may include a user confirmation of one of the change in operational state or no change in operational state.

[0136] The method may include modifying the operational state based on, for example, one of the received user input data, or based on the generated output data.

[0137] Additionally, presenting the output data may include one or more of visually presenting the output data, audibly presenting the output data, vibratorily presenting the output data, or one or more combinations thereof

[0138] Also, the operational state may include one of an analyte sensor removal state, an analyte sensor insertion state, an analyte sensor dislocation state, an analyte sensor insertion with an associated transient signal state, or an analyte sensor insertion with an associated stabilized signal state.

[0139] A data processing device in accordance with one embodiment may include a user interface unit, and a data processor operatively coupled to the user interface unit, the data processor configured to receive a signal associated with an analyte level of a user, determine whether the received signal deviates from a predetermined signal characteristic, determine an operational state associated with an analyte monitoring device, compare a prior signal associated with the analyte level of the user to the received signal, present in the user interface unit an output data associated with the operational state of the analyte monitoring device based at least in part on one or more of the received signal or the prior signal, and to receive a user input data from the user interface unit based on the presented output data.

[0140] The user interface unit in one aspect may include one or more of a user input unit, a visual display unit, an audible output unit, a vibratory output unit, or a touch sensitive user input unit.

[0141] In one embodiment, the device may include a communication unit operatively coupled to the data processor and configured to communicate one or more of the received signal, the prior signal, and the output data associated with the operational state of the analyte monitoring device, where the communication unit may include, for example, but not limited to, one of an RF transmitter, an RF receiver, an infrared data communication device, a Bluetooth® data communication device, a Zigbee® data communication device, or a wired connection.

[0142] The data processing device may include a storage unit operatively coupled to the data processor to store one or more of the received signal associated with the analyte level, the predetermined signal characteristic, the operational state associated with the analyte monitoring device, the prior signal associated with the analyte level of the user, or the output data associated with the operational state of the analyte monitoring device.

[0143] A method in accordance with still yet another embodiment may include executing a predetermined routine associated with an operation of an analyte monitoring device, detecting one or more predefined alarm conditions associated with the analyte monitoring device, outputting a first indication associated with the detected one or more predefined alarm conditions during the execution of the predetermined routine, outputting a second indication associated with the detected one or more predefined alarm conditions after the execution of the predetermined routine, where the predetermined routine is executed without interruption during the outputting of the first indication.

[0144] In one aspect, the predetermined routine may include one or more processes associated with performing a blood glucose assay, one or more configuration settings, analyte related data review or analysis, data communication routine, calibration routine, or reviewing a higher priority alarm condition notification compared to the predetermined routine, or any other process or routine that requires the user interface.

[0145] Moreover, in one aspect, the first indication may include one or more of a visual, audible, or vibratory indicators.

[0146] Further, the second indication may include one or more of a visual, audible, or vibratory indicators.

[0147] In one aspect, the first indication may include a temporary indicator, and further, and the second indication may include a predetermined alarm associated with detected predefined alarm condition.

[0148] In still another aspect, the first indication may be active during the execution of the predetermined routine, and may be inactive at the end of the predetermined routine.

[0149] Further, the second indication in a further aspect may be active at the end of the predetermined routine.

[0150] Moreover, each of the first indication and the second indication may include one or more of a visual text notification alert, a backlight indicator, a graphical notification, an audible notification, or a vibratory notification.

[0151] The predetermined routine may be executed to completion without interruption.

[0152] An apparatus in accordance with still another embodiment may include a user interface, and a data processing unit operatively coupled to the user interface, the data processing unit configured to execute a predetermined routine associated with an operation of an analyte monitoring device, detect one or more predefined alarm conditions associated with the analyte monitoring device, output on the user interface a first indication associated with the detected one or more predefined alarm conditions during the execution of the predetermined routine, and output on the user interface a second indication associated with the detected one or more predefined alarm conditions after the execution of the predetermined routine, wherein the predetermined routine is executed without interruption during the outputting of the first indication.

[0153] The predetermined routine may include one or more processes associated with performing a blood glucose assay, one or more configuration settings, analyte related data review or analysis, data communication routine, calibration routine, or reviewing a higher priority alarm condition notification compared to the predetermined routine.

[0154] The first indication or the second indication or both, in one aspect may include one or more of a visual, audible, or vibratory indicators output on the user interface.

[0155] In addition, the first indication may include a temporary indicator, and further, wherein the second indication includes a predetermined alarm associated with a detected predefined alarm condition.

[0156] Also, the first indication may be output on the user interface during the execution of the predetermined routine, and is not output on the user interface at or prior to the end of the predetermined routine.

[0157] Additionally, the second indication may be active at the end of the predetermined routine.

[0158] In another aspect, each of the first indication and the second indication may include a respective one or more of a visual text notification alert, a backlight indicator, a graphical notification, an audible notification, or a vibratory notification, configured to output on the user interface.

[0159] Various other modifications and alterations in the structure and method of operation of this invention will be apparent to those skilled in the art without departing from the scope and spirit of the invention. Although the invention has been described in connection with specific preferred embodiments, it should be understood that the invention as claimed should not be unduly limited to such specific embodiments. It is intended that the following claims define the scope of the present invention and that structures and methods within the scope of these claims and their equivalents be covered thereby.

What is claimed is:

1. A method, comprising;
 - detecting a first temperature related signal from a first source;
 - detecting a second temperature related signal from a second source, the second source located at a predetermined distance from the first source; and
 - estimating an analyte temperature related signal based on the first and second detected temperature signals.

* * * * *

专利名称(译)	在医疗通信系统中提供数据处理和控制的方法和装置		
公开(公告)号	US20160081560A1	公开(公告)日	2016-03-24
申请号	US14/961617	申请日	2015-12-07
[标]申请(专利权)人(译)	雅培糖尿病护理公司		
申请(专利权)人(译)	雅培糖尿病INC.		
当前申请(专利权)人(译)	雅培糖尿病INC.		
[标]发明人	HAYTER GARY ALAN SLOAN MARK KENT FENNELL MARTIN J		
发明人	HAYTER, GARY, ALAN SLOAN, MARK, KENT FENNELL, MARTIN, J.		
IPC分类号	A61B5/01 A61B5/00 A61B5/145 A61B5/1473		
CPC分类号	A61B5/01 A61B5/002 A61B5/7278 A61B5/14532 A61B5/7435 A61B5/1473 A61B5/4839 A61B5/14546 A61B5/1486 A61B5/6849		
优先权	60/911869 2007-04-14 US		
外部链接	Espacenet USPTO		

摘要(译)

提供了用于提供用于医疗通信系统的数据处理和控制的的方法和装置。

