



US 20150045629A1

(19) **United States**
(12) **Patent Application Publication**
AZIMI

(10) **Pub. No.: US 2015/0045629 A1**
(43) **Pub. Date: Feb. 12, 2015**

(54) **SYSTEM FOR MEASURING AND RECORDING A USER'S VITAL SIGNS**

(2013.01); *A61B 5/0402* (2013.01); *A61B 5/1118* (2013.01); *A61B 5/0022* (2013.01); *A61B 5/742* (2013.01); *A61B 5/14507* (2013.01); *A61B 5/6826* (2013.01)

(71) Applicant: **SAEED AZIMI, LOS GATOS, CA (US)**

USPC **600/301**

(72) Inventor: **SAEED AZIMI, LOS GATOS, CA (US)**

(21) Appl. No.: **13/961,441**

(57) **ABSTRACT**

(22) Filed: **Aug. 7, 2013**

A system for measuring and recording data pertaining to a user's vital signs in response to a single action by the user is provided. The system includes a base unit with a computer system, metallic layers affixed to a first side face and a bottom face of the base unit, an aperture, and a flexible shaft extending from the bottom face of the base, and an extension member pivotably mounted to a second side face of the base unit. The system receives the user's thumb on the metallic layer located on the first side face, index finger between the base unit and the extension member, lips on the bottom face metallic layer and tongue above the flexible shaft to capture the vital signs data and communicate the data to the remote location.

Publication Classification

(51) **Int. Cl.**

A61B 5/0205 (2006.01)
A61B 5/145 (2006.01)
A61B 5/11 (2006.01)
A61B 5/00 (2006.01)
A61B 5/1455 (2006.01)
A61B 5/0402 (2006.01)

(52) **U.S. Cl.**

CPC *A61B 5/02055* (2013.01); *A61B 5/14551*

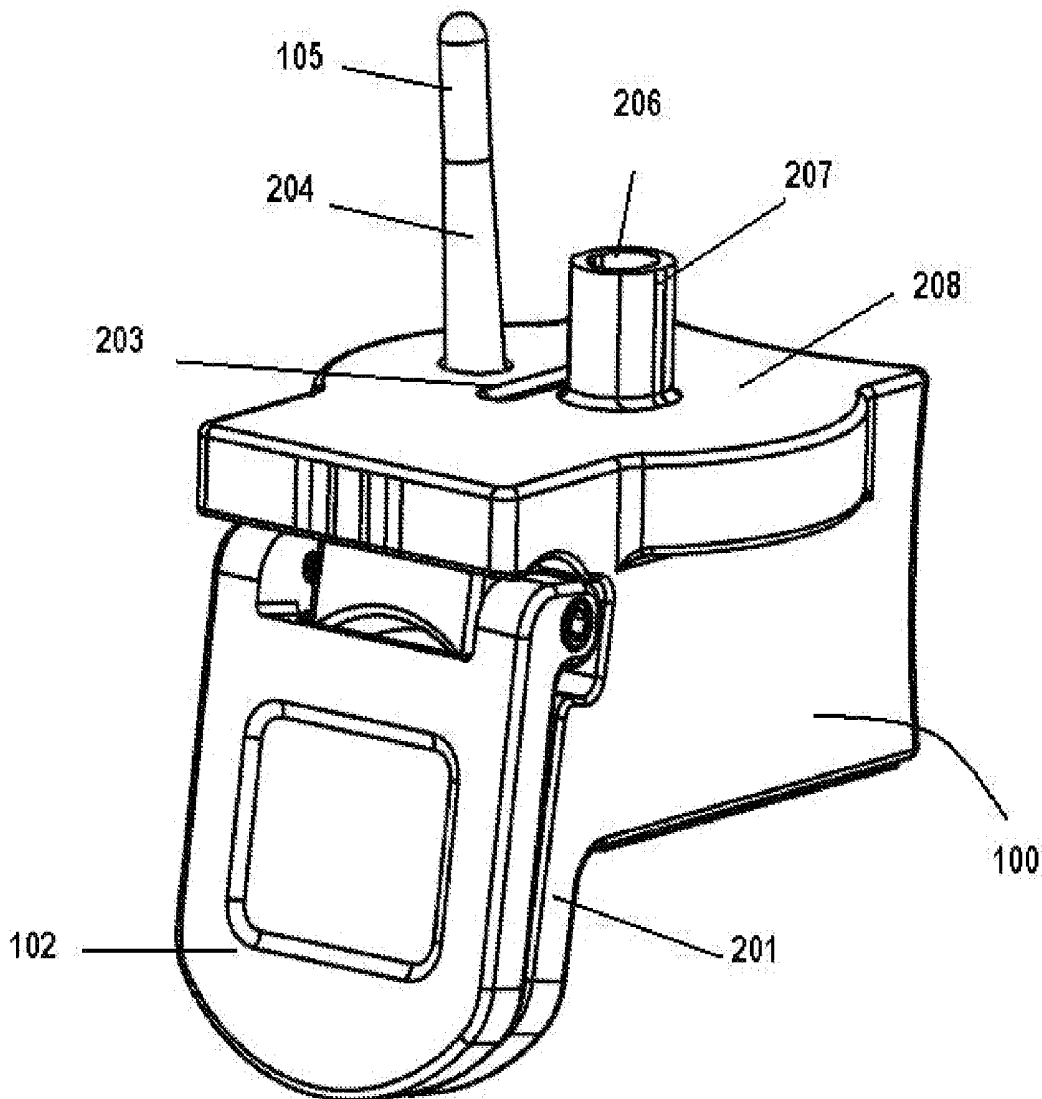

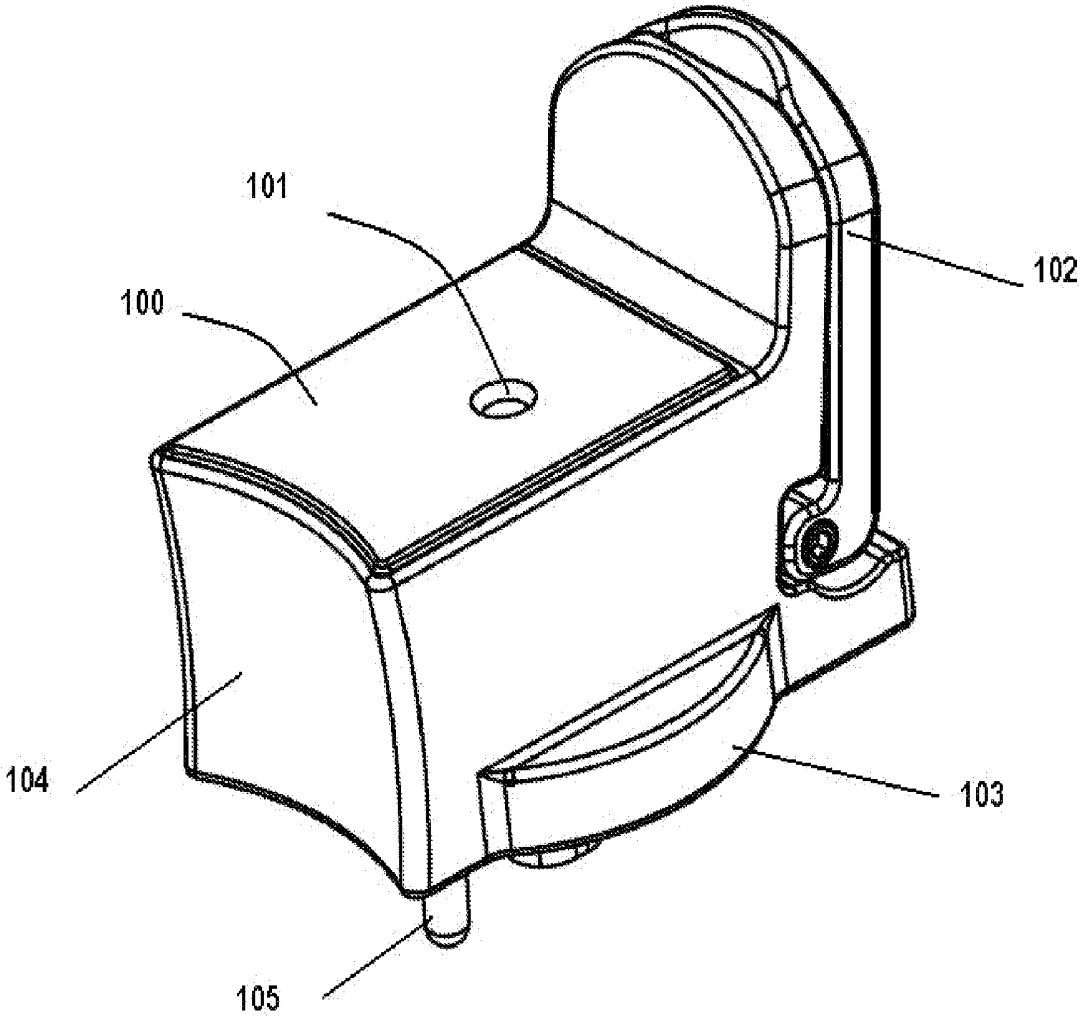

FIG. 1

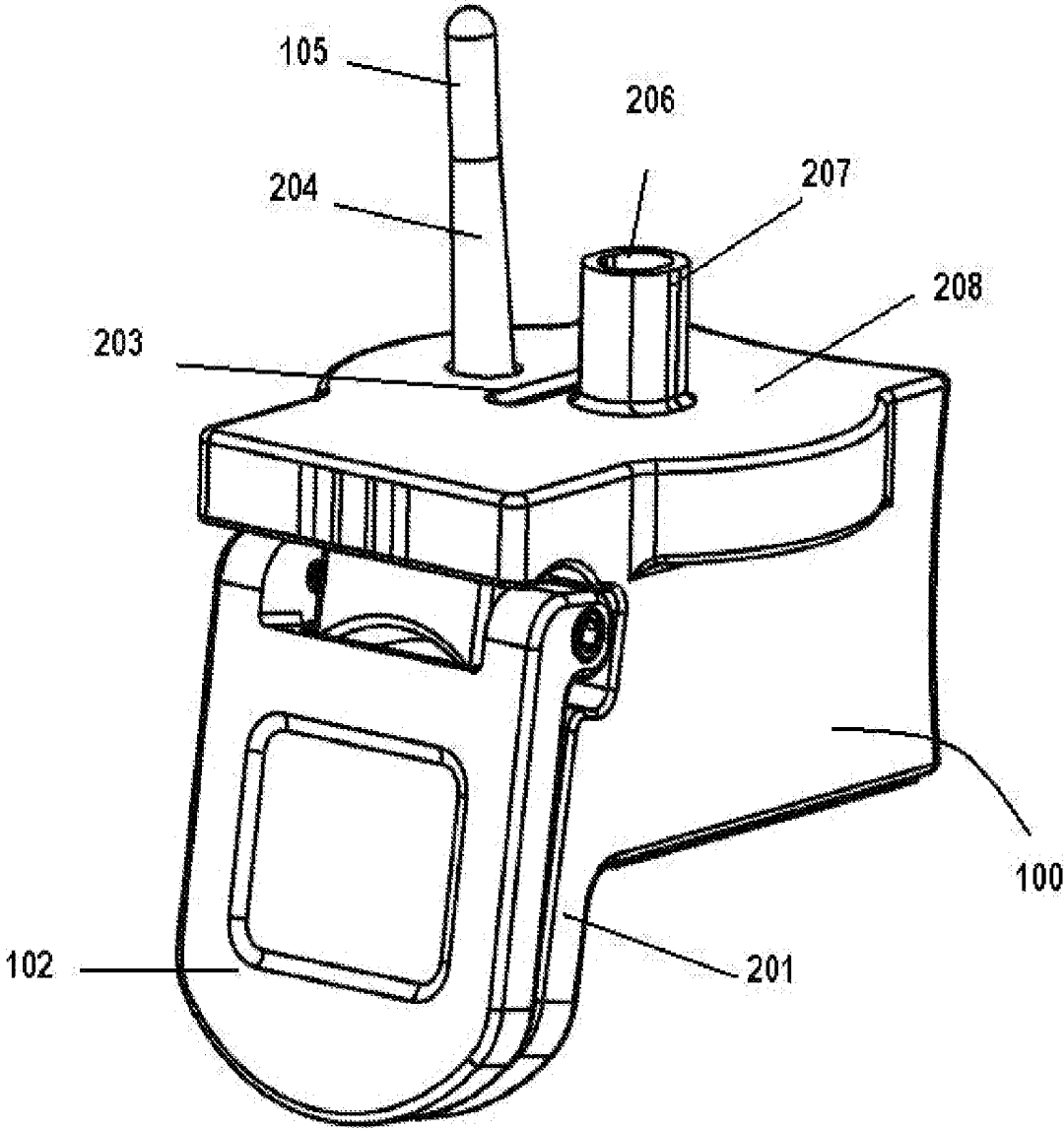

FIG. 2

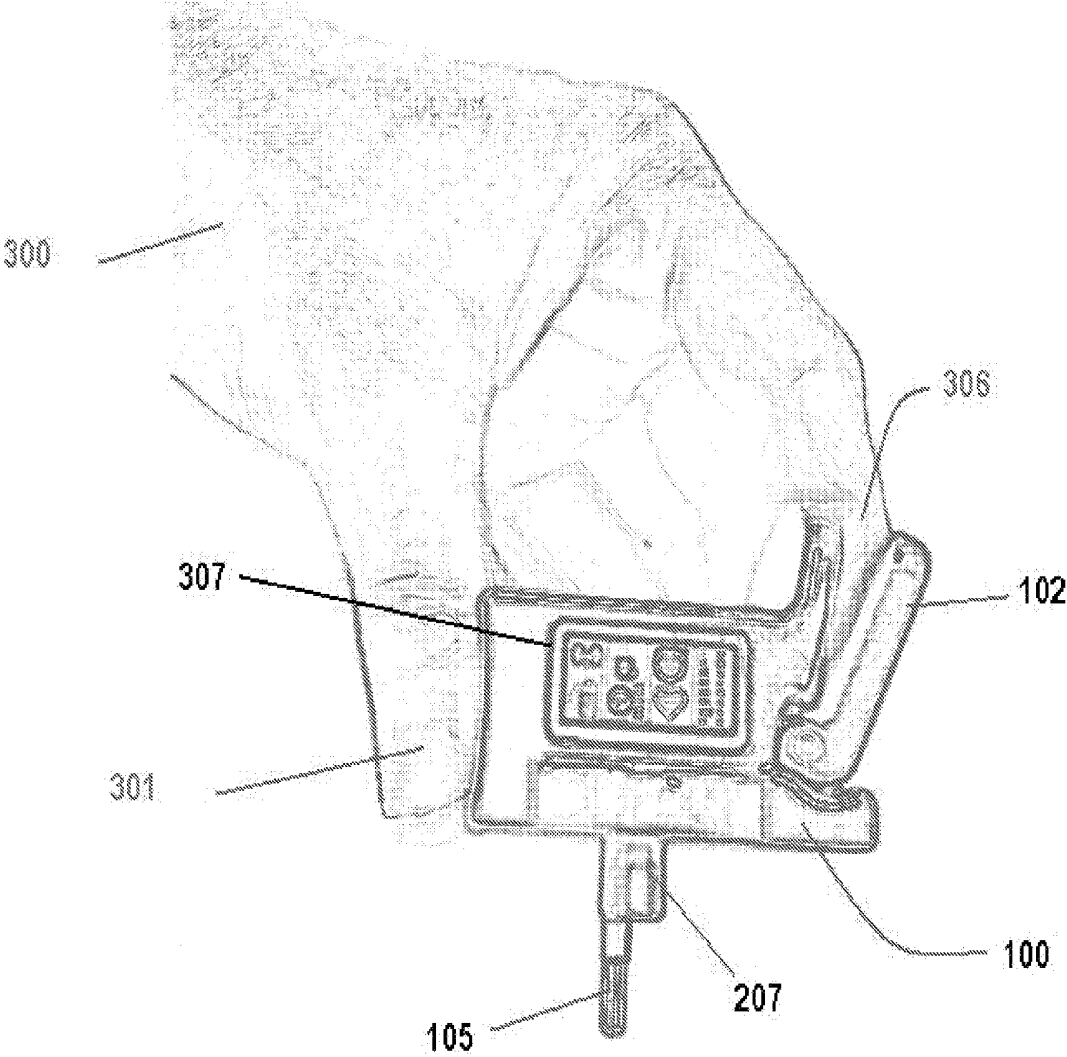

FIG. 3

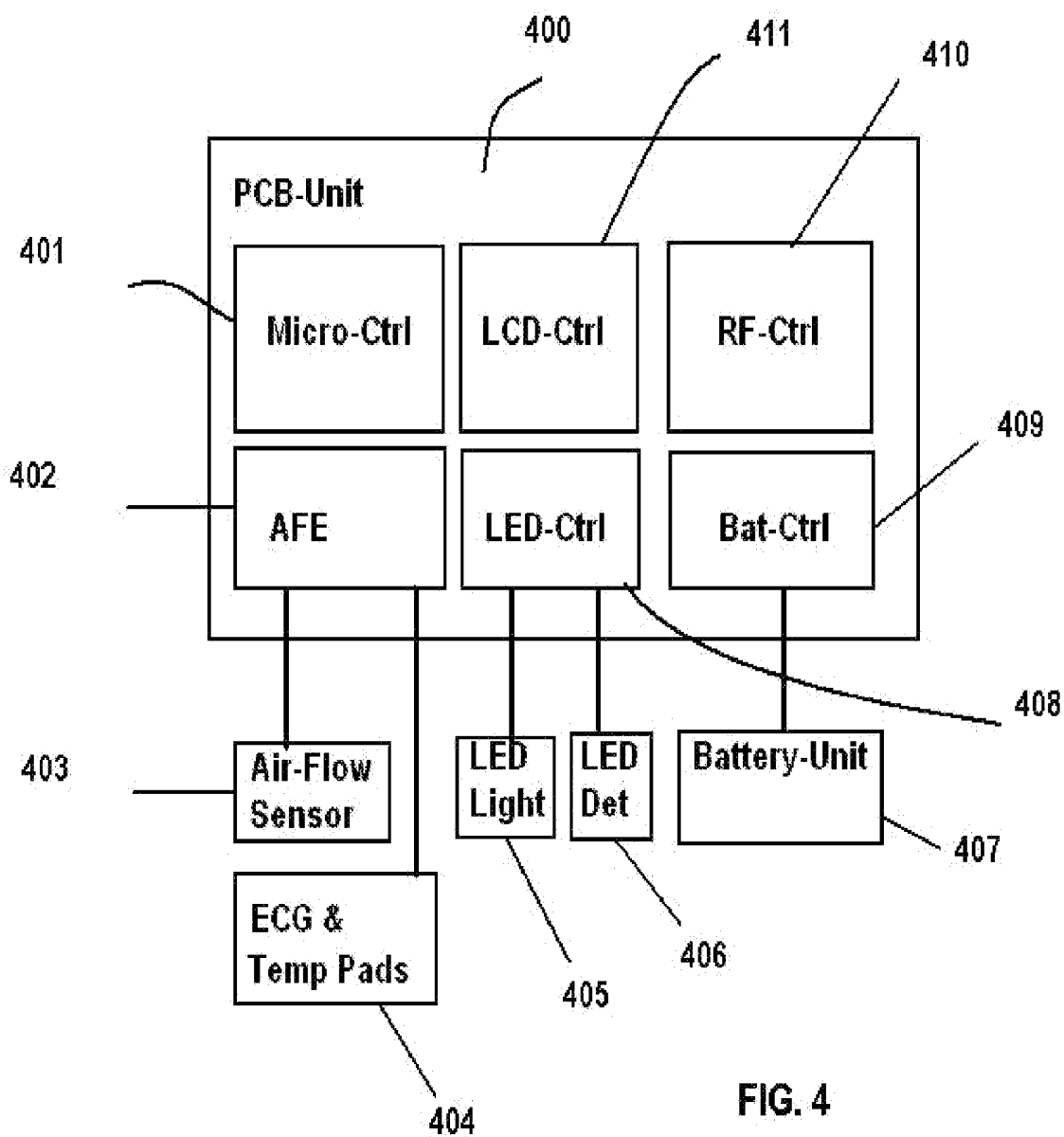

FIG. 4

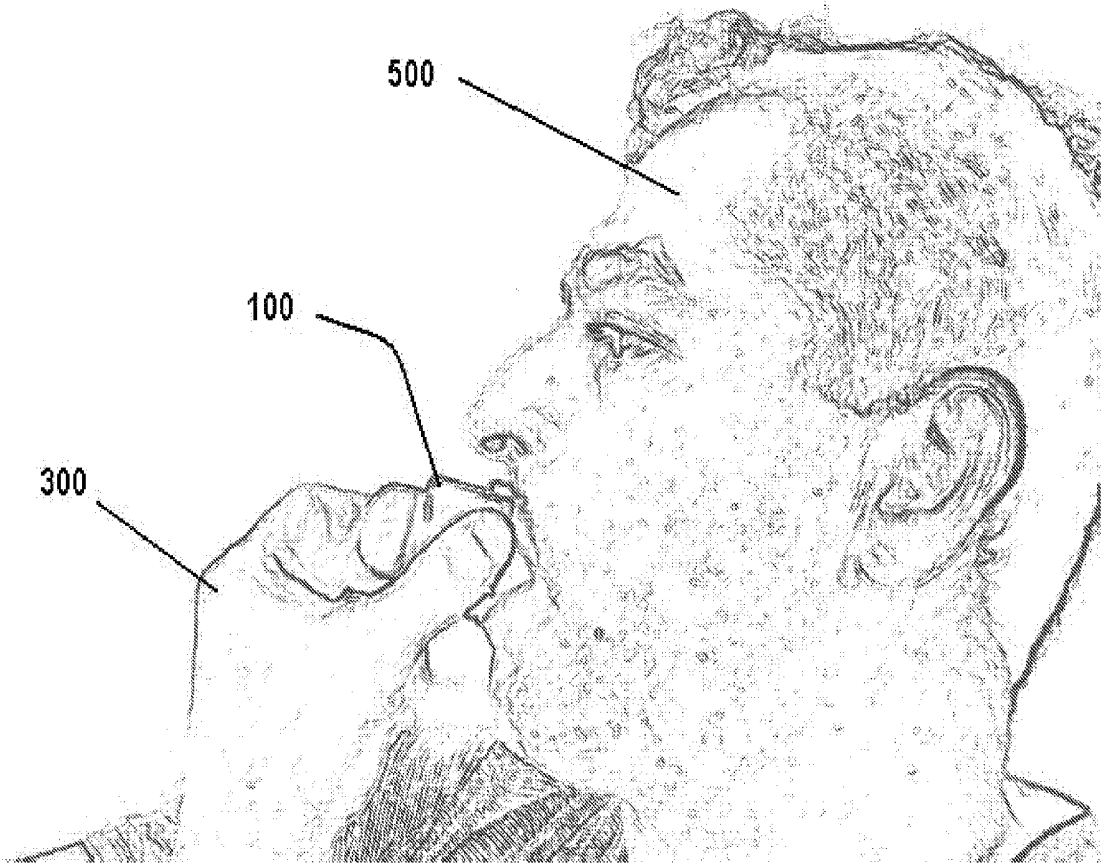

FIG. 5

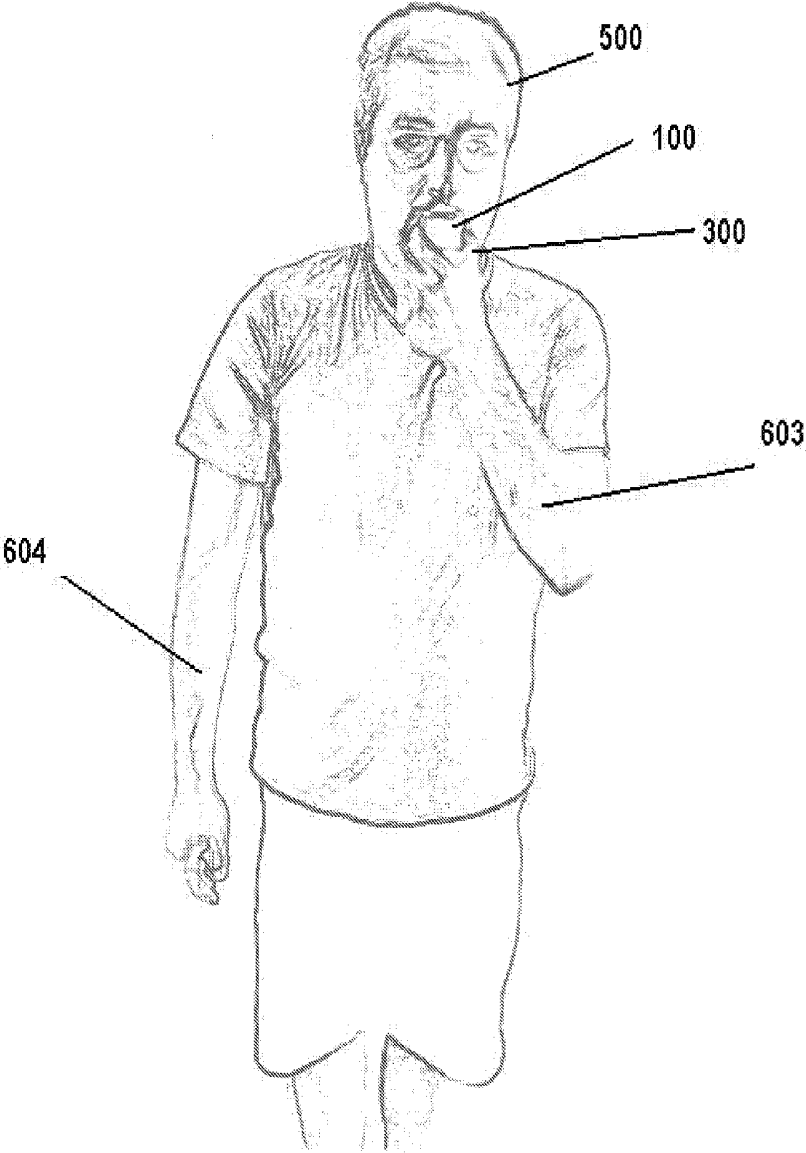

FIG. 6

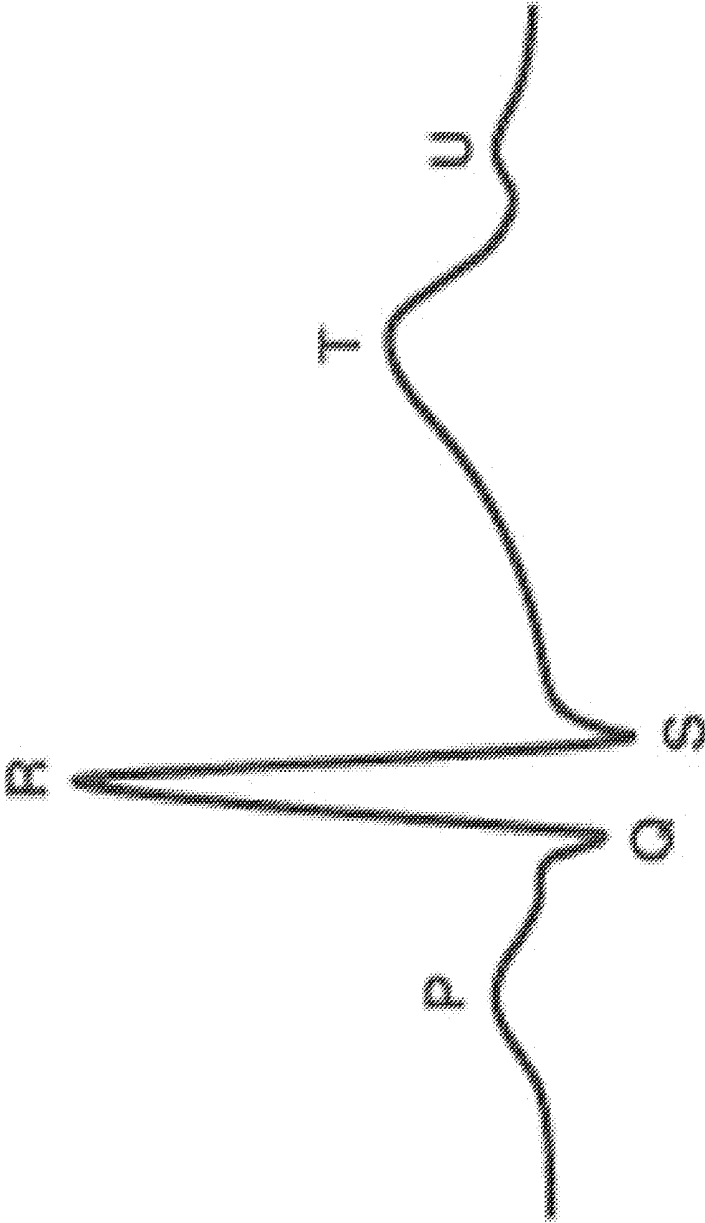

FIG. 7

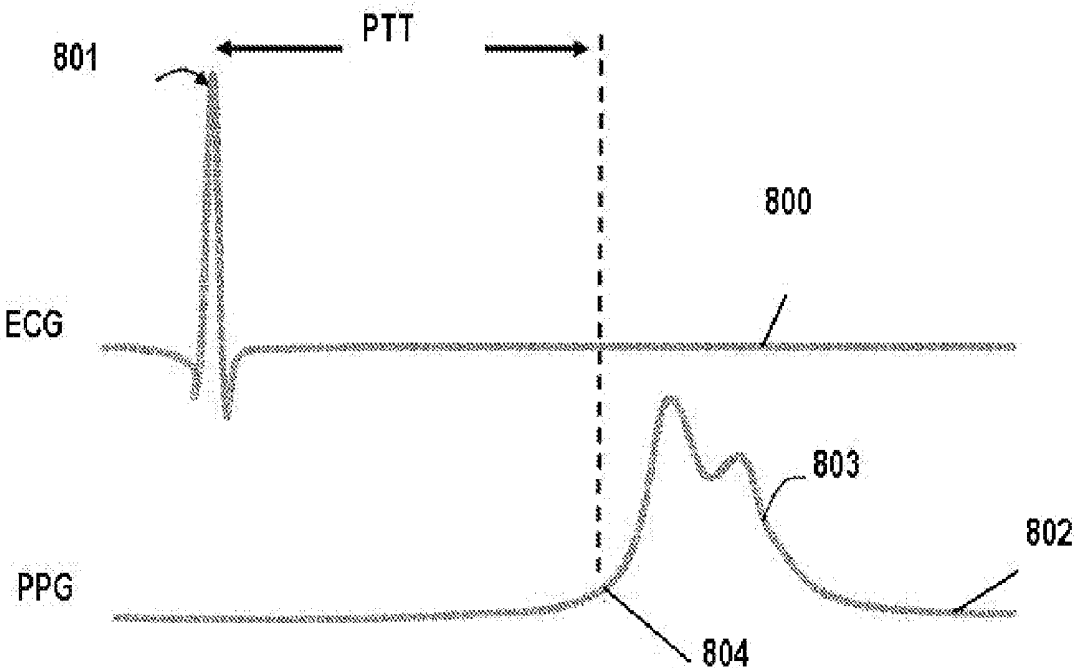

FIG. 8

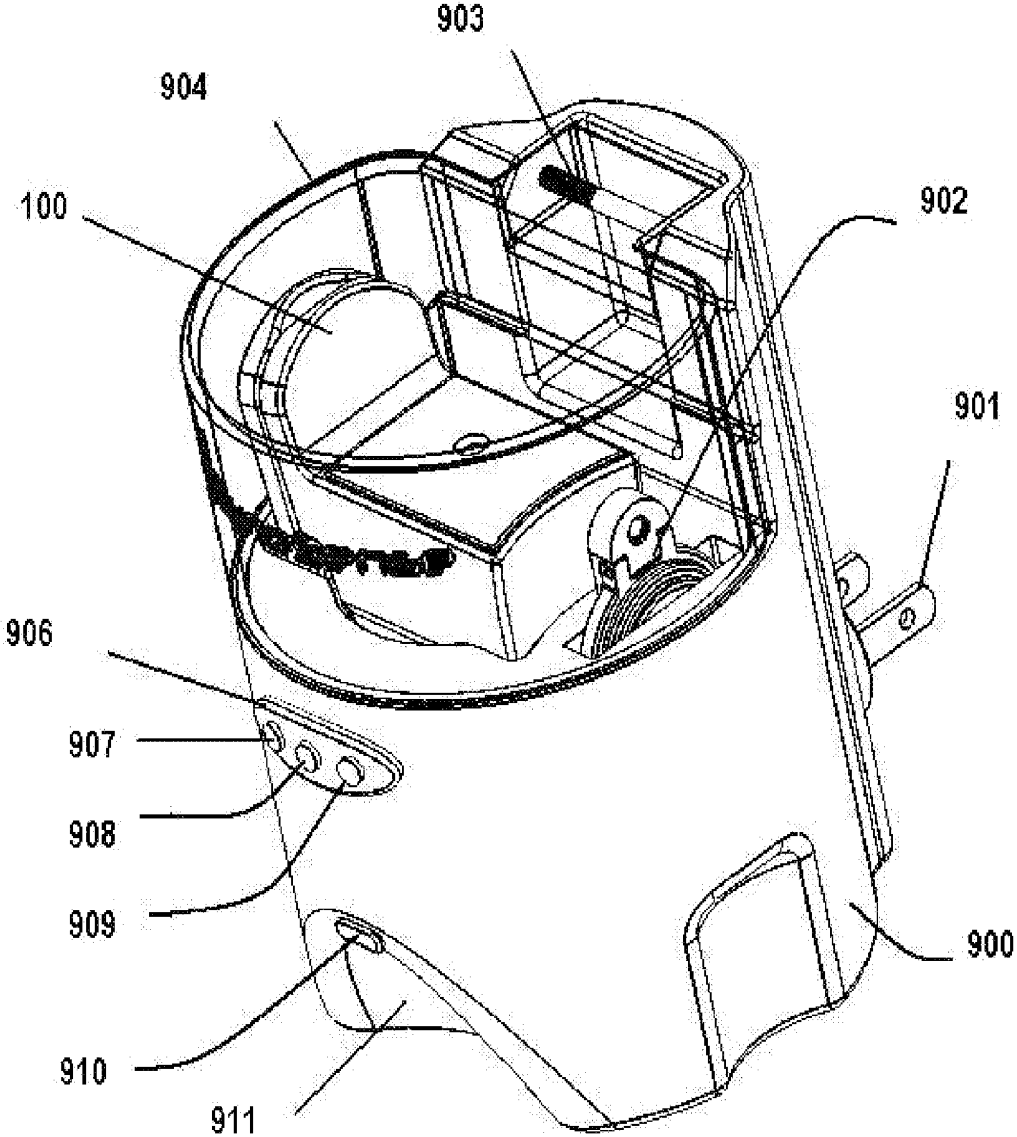

FIG. 9

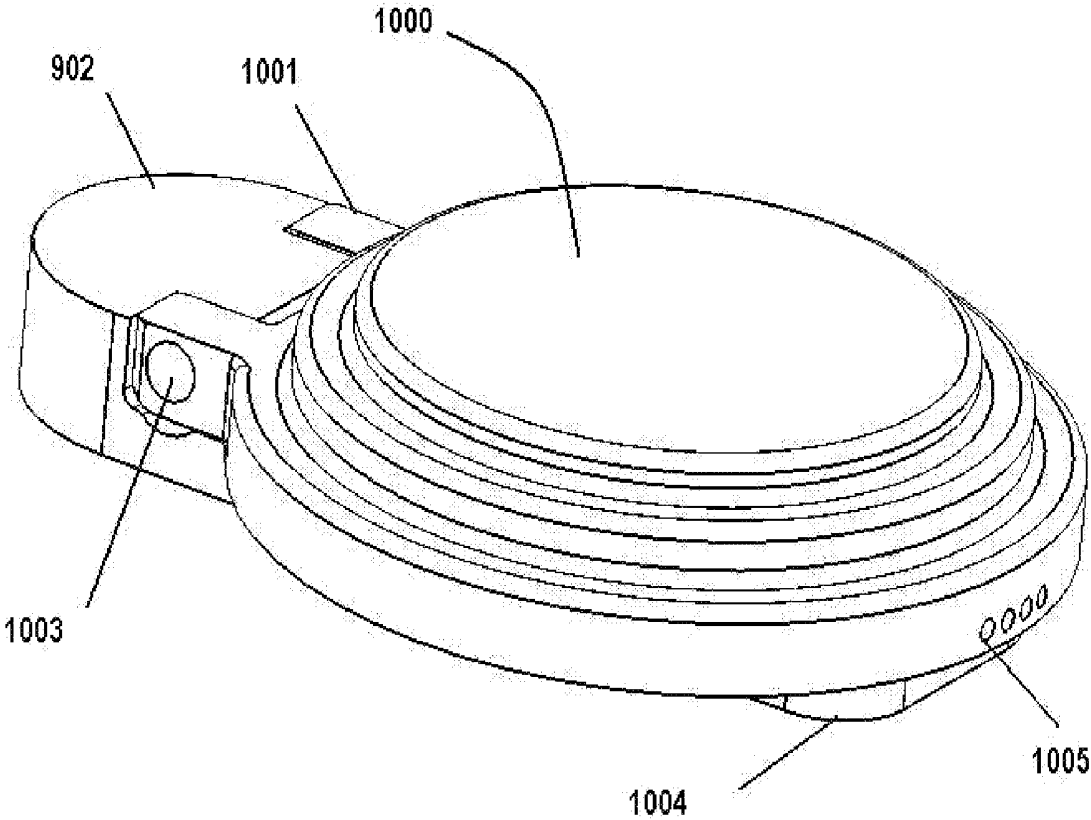

FIG. 10

SYSTEM FOR MEASURING AND RECORDING A USER'S VITAL SIGNS

BACKGROUND

[0001] The embodiments herein relate generally to systems for measuring and recording a body's vital signs such as blood oxygen levels, respiratory characteristics, heart electrical signatures (electrocardiography or ECG), heart rate, blood pressure and temperature for health monitoring applications.

[0002] Currently there exist several systems that use multiple sensors connected to a single base unit, which is able to collectively measure all vital signs. These integrated units still require a user to connect two or more sensors to a particular location on the body. For example, a conventional pulse oximetry system used for the measurement of blood oxygen comprises a sensor attached to a user's finger, an oral thermometer requires placement under the tongue or arm, an infrared thermometer is placed in the ear canal, an ECG sensor requires two probes placed across the heart, and most blood pressure monitors use either auscultatory or oscillometric methods, which require a cuff to be worn on the user's arm. These systems have limitations because they are bulky or heavily power dependent and/or they require multiple attachments and actions by the user in order to measure and record the vital signs data.

[0003] As such, there is a need in the industry for a system that can detect and record all critical vital signs with a single action by the user.

SUMMARY

[0004] A system for measuring and recording data pertaining to a user's vital signs in response to a single action by the user, the system being configured to analyze and communicate the data to a remote location is provided. The system comprises a base unit comprising a computer system, metallic layers affixed to a first side face and a bottom face of the base unit, an aperture, and a flexible shaft extending from the bottom face of the base, and an extension member pivotably mounted to a second side face of the base unit, wherein the system is configured to receive the user's thumb on the metallic layer located on the first side face, index finger between the base unit and the extension member, lips on the bottom face metallic layer and tongue above the flexible shaft to capture the vital signs data and communicate the data to the remote location.

BRIEF DESCRIPTION OF THE FIGURES

[0005] The detailed description of some embodiments of the invention will be made below with reference to the accompanying figures, wherein the figures disclose one or more embodiments of the present invention.

[0006] FIG. 1 depicts a perspective view of certain embodiments of the invention;

[0007] FIG. 2 depicts a perspective view of certain embodiments of the invention;

[0008] FIG. 3 depicts a side view of certain embodiments of the invention in use;

[0009] FIG. 4 depicts a block diagram of a computer system of certain embodiments of the invention;

[0010] FIG. 5 depicts a side view of certain embodiments of the invention in use;

[0011] FIG. 6 depicts a front view of certain embodiments of the invention in use;

[0012] FIG. 7 depicts an electrocardiography waveform analyzed in certain embodiments of the invention;

[0013] FIG. 8 depicts a series of electrocardiography waveforms analyzed in certain embodiments of the invention;

[0014] FIG. 9 depicts a perspective view of certain embodiments of the invention; and

[0015] FIG. 10 depicts a perspective view of certain embodiments of the invention.

DETAILED DESCRIPTION OF CERTAIN EMBODIMENTS

[0016] FIGS. 1-3 depict certain embodiments of the system for measuring a user's vital signs. The system 100 comprises a base unit comprising aperture 101, extension member 102, interior housing 103 comprising a computer system, contoured metallic pad 104, sensing tip 105, base unit extension 201, tongue resting area 203, flexible shaft 204, aperture (air opening) 206, air shaft 207, bottom metallic layer 208 and touch screen 307. Extension member 102 may be pivotably mounted to base unit extension 201 by any known components in the field such as a compression spring.

[0017] In certain embodiments of the invention, a first LED device is attached to extension member 102 and a second LED device is attached to base unit extension 201. These LED devices may comprise any known components in the field such as lights or detectors, which may comprise photoplethysmographs (PPG) or plethysmographs. One common use of photoplethysmography can be found in pulse oximeters, which determine the oxygen saturation of arterial blood and measures the change in the volume of arterial blood with each pulse beat. Pulse oximeter devices contain two light emitting diodes: one in the red band of light (660 nanometers) and one in the infrared band of light (940 nanometers). Oxyhemoglobin absorbs infrared light while deoxyhemoglobin absorbs visible red light. Pulse oximeter devices also contain sensors that detect the ratio of red/infrared absorption several hundred times per second. A preferred algorithm for calculating the absorption is derived from the Beer-Lambert Law, which determines the transmitted light from the incident light multiplied by the exponential of the negative of the product of the distance through the medium, the concentration of the solute and the extinction coefficient of the solute.

[0018] FIG. 4 depicts the computer system, which comprises PCB-Unit 400, processor 401, Analog Front End (AFE) unit 402, which provides analog filtering, biasing and digitization of Air-Flow Sensor 403, which detects the user's breathing and acoustic sounds from the body. AFE unit 402 also provides analog filtering, biasing and digitization of ECG and Temperature Pads 404 located at metallic pad 104 and bottom metallic layer 208. LED-Controller unit 408 provides filtering, biasing and digitization of LED-Light 405 and LED-Detector 406 placed on extension member 102 and base unit extension 201, or vice versa, for detecting data related to a photoplethysmograph (PPG). Battery-Controller unit 409 provides power for all electronics of the system from battery source 407. RF-Controller 410 provides a wireless connection for transmitting and receiving data to system 100. LCD-Controller 411 displays information and receives an input from a user on touch screen 307.

[0019] FIGS. 3 and 5-6 depict certain embodiments of the invention in use. A user 500 uses left hand 300 to hold system 100. The user's left thumb 301 is placed on contoured metal-

lic pad **104** and left index finger **306** is placed between extension member **102** and base unit extension **201**. System **100** is placed inside the user's mouth while held by left hand **300** such that sensing tip **105** on flexible shaft **204** is under the user's tongue below air shaft **207** with the tongue touching (or resting) on tongue resting area **203**. In this position, air opening **206** is above the user's tongue and the lips are placed on bottom metallic layer **208** such that breathing is accomplished through the user's nose via air rushing through apertures **101** and **206**.

[0020] In this setup, the computer system of system **100** senses electrical signals between thumb **301** placed on metallic pad **104** and bottom metallic layer **208** to construct an ECG signal as shown in FIG. 7. The computer system then calculates all heart related data from the ECG signal of FIG. 7, also referred to as a "QRS" complex wave. As the user breathes, the flow of air is sensed by the computer system by the amount of air rushing in and out of apertures **101** and **206**, therefore yielding respiratory data. Sensing tip **105** measures the user's body temperature under the tongue. The LED detector measures data related to a PPG based on the reflection of LED light when the user's left index finger **306** is placed between extension member **102** and base unit extension **201**. In this configuration, the index finger is placed between LED-Light **405** and LED-Detector **406**.

[0021] From constructed ECG signal **800** and PPG signal **802** it is then possible to construct the Pulse Transit Time ("PTT") shown in FIG. 8. PTT, defined as the transit time for a pressure pulse launched by a heartbeat in a patient's arterial system, has been shown in the prior art to correlate to both systolic and diastolic blood pressure. The QRS complex **800** indicates an initial depolarization of ventricles within the heart and, informally, marks the beginning of the heartbeat **801** and a pressure pulse that follows. Pulse oximetry is measured as described above on the user's left index finger. Time-dependent features of the optical waveform indicate both pulse rate and a volumetric absorbance change in an underlying artery in the finger caused by the propagating pressure pulse.

[0022] PTT measurements determine the time separating a maximum point on the QRS complex (indicating the peak of ventricular depolarization) **801** and a foot of the optical waveform **804** (indicating beginning of the pressure pulse) with **803** indicating the trailing end. PTT depends primarily on arterial compliance, the propagation distance of the pressure pulse (which is closely approximated by the patient's arm length **603** or **604**), and blood pressure. To account for patient-dependent properties, such as arterial compliance, PTT-based measurements of blood pressure are 'calibrated' using a conventional blood pressure cuff. During the calibration process the blood pressure cuff is applied to the patient, used to make one or more blood pressure measurements, and then removed. Going forward, the calibration blood pressure measurements are used, along with a change in PTT, to determine the patient's blood pressure and blood pressure variability. PTT typically relates inversely to blood pressure, i.e., a decrease in PTT indicates an increase in blood pressure.

[0023] In certain embodiments of the invention, the vital signs data is displayed to the user on touch screen **307**. In FIG. 9, cradle unit **900** charges system **100**, cleans and sterilizes the system after each use. Cradle unit **900** can interact with a user using various LED colors **907**, **908**, **909** or **910**, press button **906**, as well as via voice command with built-in speaker and microphones **911**. Furthermore, unit **900** has a

wireless (Wi-Fi) or wired connection (Ethernet) to the Internet, which allows system **100** to communicate using short wavelength frequencies such as Bluetooth Radio. This configuration allows for a two way communication of cloud-based computer applications with system **100**. Therefore, system **100** can transmit all vital signs data to the Internet and receive new programming from external cloud applications. Cradle unit **900** can also optionally communicate with other devices such as a weight scale, blood test kits, blood pressure cuff or other medical appliances.

[0024] Cradle unit **900** gets power from wall outlet **901**. A user places system **100** inside cradle unit **900** after each use by lifting lid **904** around pivot point **903**. Optionally, there is activity tracking unit **902** that is also part of cradle unit **900**. Referring to FIG. 10, activity tracker unit **902** comprises top face **1000**, a motion sensor that is attached to the user's body using clips **1004** with pivot point **1003** and **1001** preferably on an undershirt for men and a bra-strap for women. The activity tracker unit **902** is charged using cradle unit **900** by being placed inside a slot in the cradle unit **900** via access ports **1005**. The activity tracker also communicates with cradle unit **900** wirelessly. It shall be appreciated that activity tracker unit **902** may collect additional data about the user's body and/or activities.

[0025] In operation, as shown in FIG. 6, user **500** removes system **100** from cradle unit **900** (typically after brushing their teeth or at other times), and places it in the mouth with left hand **300** while relaxing right hand **604** typically in standing position while left arm **603** is in a bent position. The computer system calculates and captures all body vital signs accurately, typically in less than 30 seconds when an audible sound is heard instructing the user to remove system **100** from the mouth. System **100** is then washed and placed back into cradle unit **900**. The user can selectively review the data on touch screen **307** or visit a website by logging into an account and reviewing the data.

[0026] In one embodiment, the system generates alerts and alarms if it detects that any values of the vital signs are outside the normal limits. The system may generate messages (e.g., email or SMS messages) containing such information to be sent to the doctor, the user, and/or any such person chosen by the user.

[0027] In an alternative embodiment, system **100** has access to body saliva samples during operation of sensing vital signs. Body saliva is similar to blood in many ways and therefore detectors can be developed to obtain, analyze and detect other non-vital sign data about the body such as glucose level, influenza A or B, alcohol or drug levels and DNA analyses.

[0028] It shall be appreciated that the components of the system described in several embodiments herein may comprise any known materials in the field such as metals and molded plastics, and be of any color, size and/or dimensions.

[0029] Persons of ordinary skill in the art may appreciate that numerous design configurations may be possible to enjoy the functional benefits of the inventive systems. Thus, given the wide variety of configurations and arrangements of embodiments of the present invention the scope of the invention is reflected by the breadth of the claims below rather than narrowed by the embodiments described above.

What is claimed is:

1. A system for measuring and recording data pertaining to a user's vital signs in response to a single action by the user,

the system being configured to analyze and communicate the data to a remote location, the system comprising:

a base unit comprising a computer system, metallic layers affixed to a first side face and a bottom face of the base unit, an aperture, and a flexible shaft extending from the bottom face of the base unit; and

an extension member pivotably mounted to a second side face of the base unit;

wherein the system is configured to receive the user's thumb on the metallic layer located on the first side face, index finger between the base unit and the extension member, lips on the bottom face metallic layer and tongue above the flexible shaft to capture the vital signs data and communicate the data to the remote location.

2. The system of claim 1, further comprising a display configured to receive an input from the user and display to the user vital signs data.

3. The system of claim 1, wherein the extension member comprises a light-emitting diode device configured to be used as a plethysmograph.

4. The system of claim 1, wherein the computer system is configured to transmit an alert to an entity if any values of the user's vital signs data are outside normal limits.

5. The system of claim 1, wherein the computer system generates an electrocardiography signal based on electrical signals detected by the metallic layers.

6. The system of claim 1, wherein the computer system detects airflow through the aperture based on a breath of the user and generates respiratory data based on the detected airflow.

7. The system of claim 1, further comprising a detector configured to measure and record data pertaining to the user's non-vital signs.

8. The system of claim 1, further comprising a cradle unit configured to store, clean and sterilize the base unit and the extension member.

9. The system of claim 8, further comprising an activity tracker unit configured to collect data pertaining to the user's activities.

10. The system of claim 8, wherein the cradle unit comprises a communication device configured to wirelessly communicate the vital signs data to the remote location and other devices.

* * * * *

专利名称(译)	用于测量和记录用户生命体征的系统		
公开(公告)号	US20150045629A1	公开(公告)日	2015-02-12
申请号	US13/961441	申请日	2013-08-07
[标]申请(专利权)人(译)	阿芝米SAEED		
申请(专利权)人(译)	阿芝米, SAEED		
当前申请(专利权)人(译)	阿芝米, SAEED		
[标]发明人	AZIMI SAEED		
发明人	AZIMI, SAEED		
IPC分类号	A61B5/0205 A61B5/145 A61B5/11 A61B5/00 A61B5/1455 A61B5/0402		
CPC分类号	A61B5/02055 A61B5/14551 A61B5/0402 A61B5/6826 A61B5/0022 A61B5/742 A61B5/14507 A61B5/1118 A61B5/0205 A61B5/02125 A61B5/1455 A61B5/682 A61B2560/0406 A61B2562/06		
其他公开文献	US9161697		
外部链接	Espacenet USPTO		

摘要(译)

提供了一种用于响应于用户的单个动作来测量和记录与用户生命体征有关的数据的系统。该系统包括具有计算机系统的基座单元，固定到基座单元的第一侧面和底面的金属层，孔和从基座的底面延伸的柔性轴，以及可枢转地安装的延伸构件到基座单元的第二侧面。系统在位于第一侧面上的金属层上接收用户的拇指，在基座单元和延伸构件之间的食指，底面金属层上的唇缘和柔性轴上方的舌部接收用户的拇指以捕获生命体征数据并传达数据到远程位置。

