



US 20190167138A1

(19) **United States**

(12) **Patent Application Publication**
Ollivier

(10) **Pub. No.: US 2019/0167138 A1**
(43) **Pub. Date: Jun. 6, 2019**

(54) **LEAD FOR AN ACTIVE IMPLANTABLE MEDICAL DEVICE WITH A CHIP FOR ELECTRODE MULTIPLEXING**

A61B 5/00 (2006.01)
A61N 1/05 (2006.01)
H01R 43/20 (2006.01)

(71) Applicant: **SORIN CRM SAS**, Clamart (FR)

(52) **U.S. Cl.**
CPC *A61B 5/0408* (2013.01); *A61B 5/0215* (2013.01); *A61B 5/686* (2013.01); *A61N 1/0587* (2013.01); *A61B 2562/125* (2013.01); *A61N 1/05* (2013.01); *Y10T 29/49171* (2015.01); *Y10S 439/909* (2013.01); *H01R 43/20* (2013.01)

(72) Inventor: **Jean-François Ollivier**, Gif sur Yvette (FR)

(73) Assignee: **SORIN CRM SAS**, Clamart (FR)

(21) Appl. No.: **16/252,279**

(22) Filed: **Jan. 18, 2019**

(57) **ABSTRACT**

Related U.S. Application Data

(63) Continuation of application No. 14/696,064, filed on Apr. 24, 2015, now Pat. No. 10,182,730, which is a continuation of application No. 13/325,930, filed on Dec. 14, 2011, now Pat. No. 9,020,574.

Foreign Application Priority Data

Dec. 14, 2010 (FR) 1060452

Publication Classification

(51) **Int. Cl.**
A61B 5/0408 (2006.01)
A61B 5/0215 (2006.01)

A lead for active implantable medical devices comprising a chip, notably for electrode multiplexing. The lead includes an insulating supporting tube interposed in a flexible elongated tube, with a central bore coaxial with the lumen of the lead. The supporting tube comprises on its surface at least one crossing conductive strip extending in the axial direction. A chip on a flexible substrate is disposed with a bent or curved conformation in a receptacle of the supporting tube isolated from the conductive strip. An electrode, e.g., for cardiac sensing/pacing, carried by the supporting tube is electrically connected to an outer conductive pad of the chip. The conductive strip is connected (i) at each end, face to face to a conductive connection, housed in the sheath, and (ii) in a central region, to an inner conductive pad of the chip.

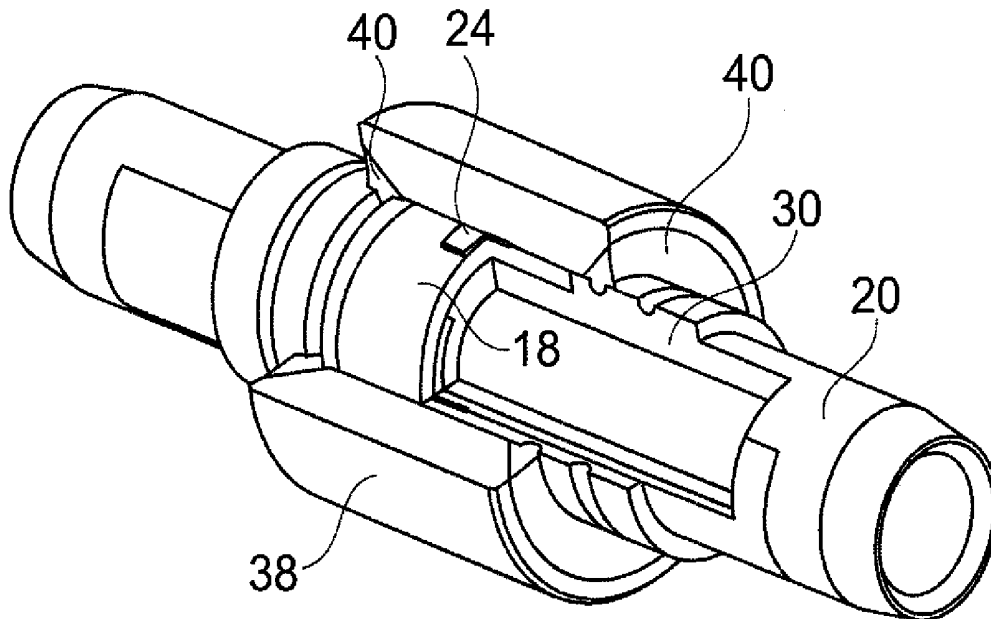

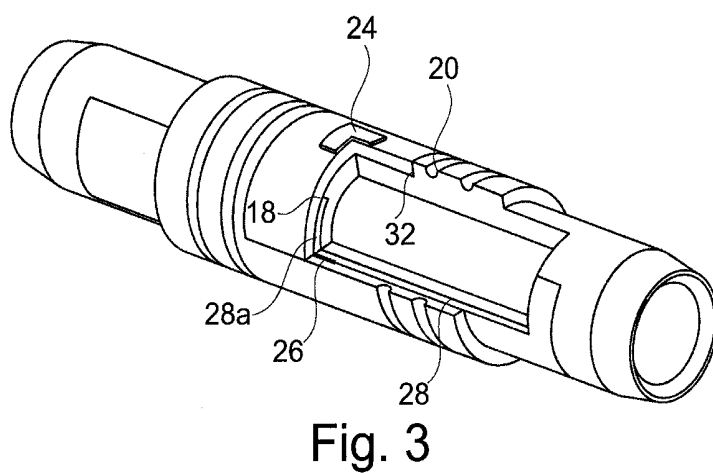
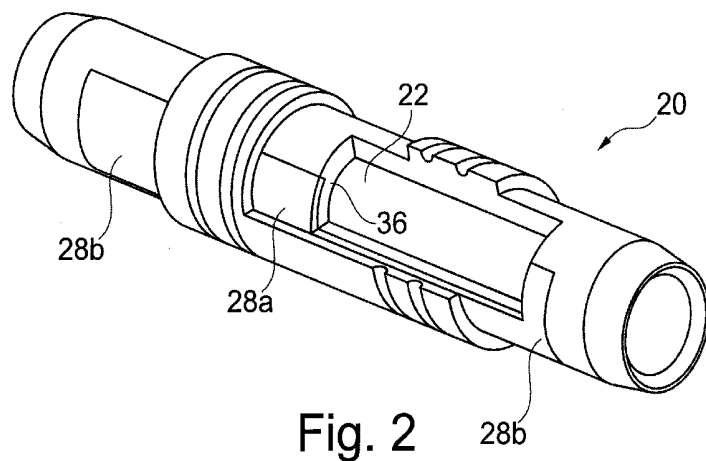
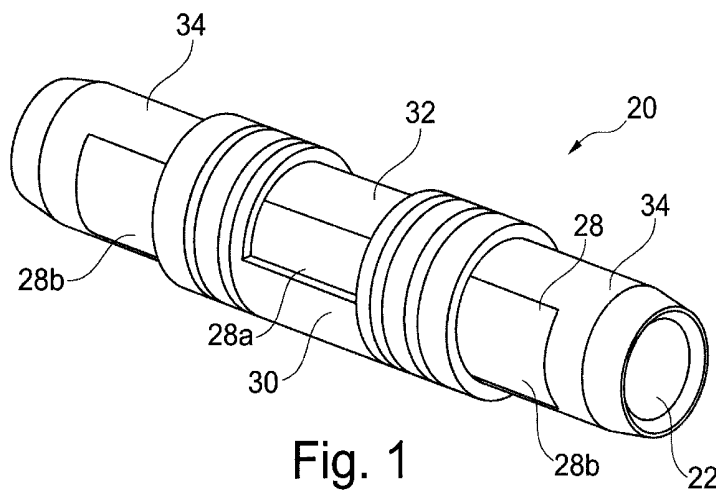

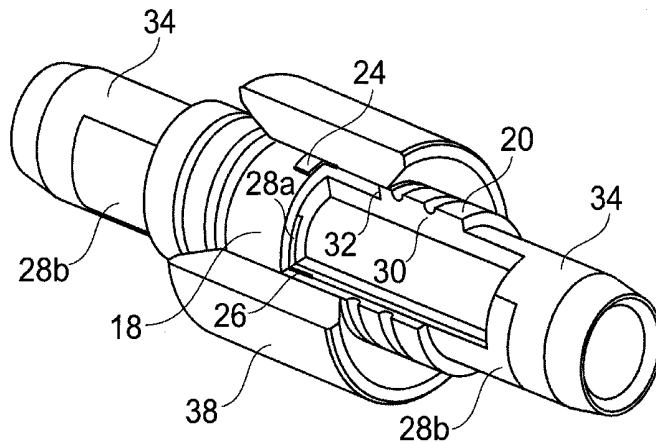

Fig. 4

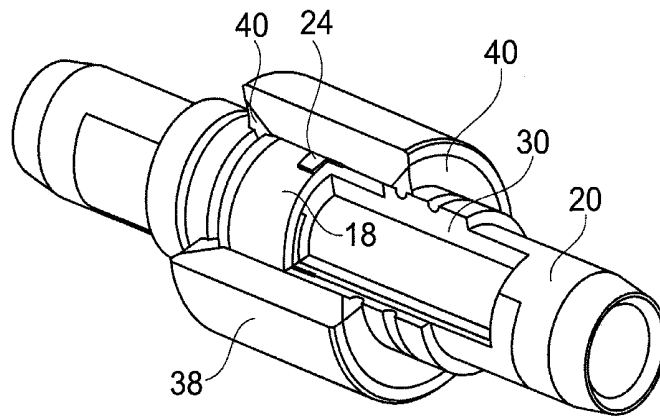

Fig. 5

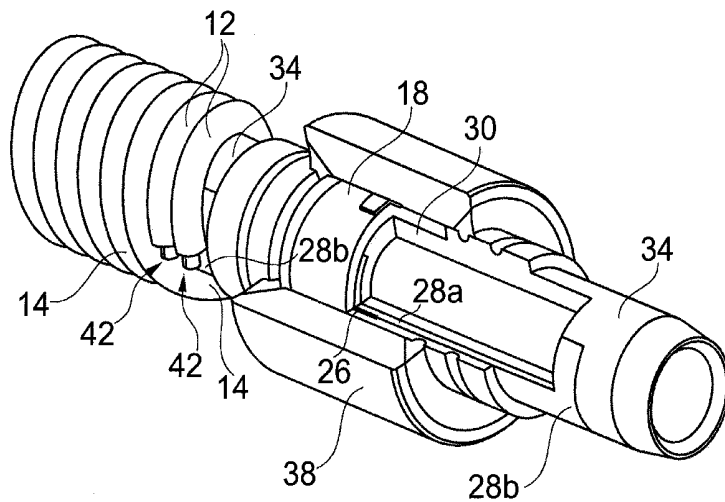

Fig. 6

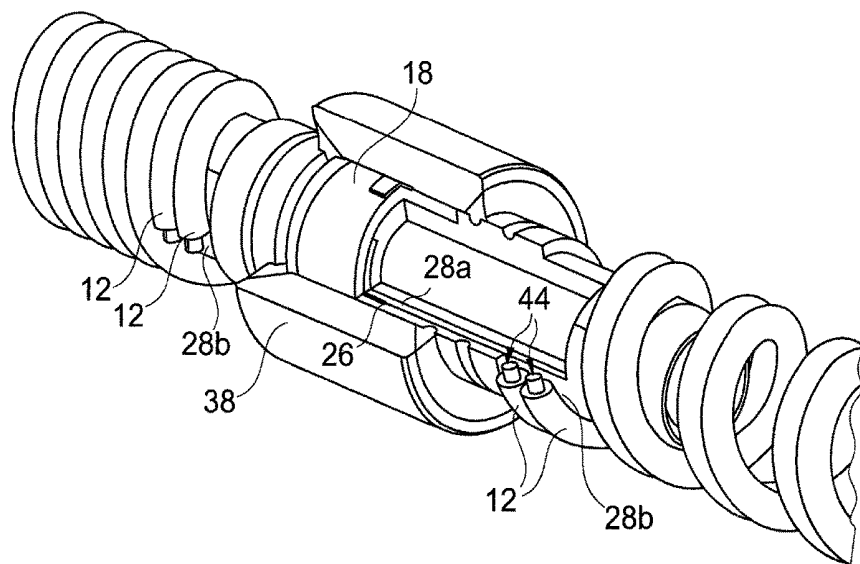

Fig. 7

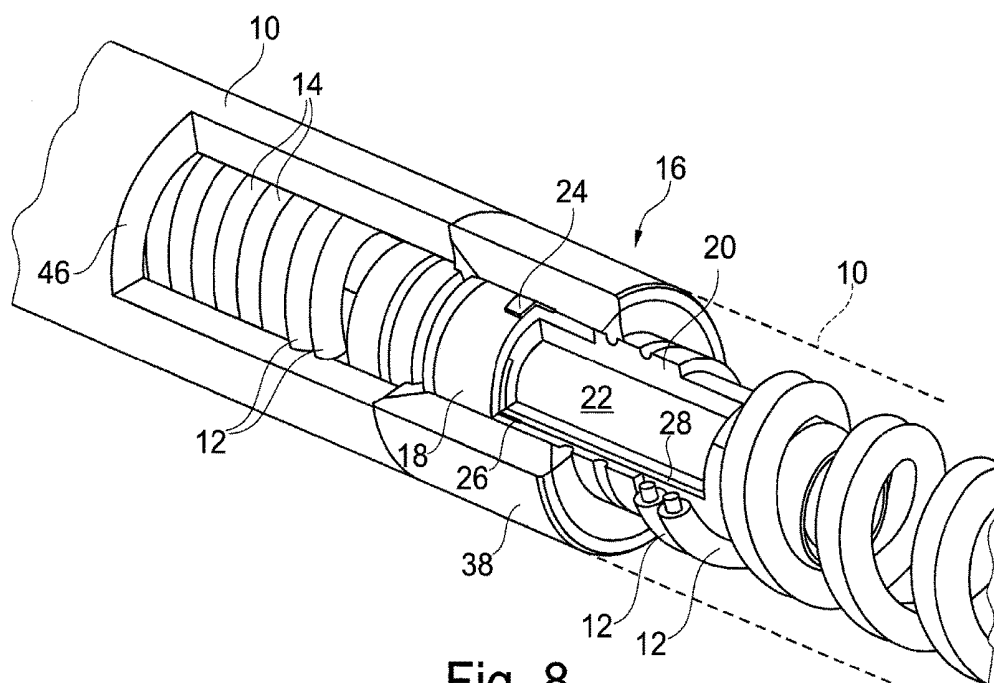

Fig. 8

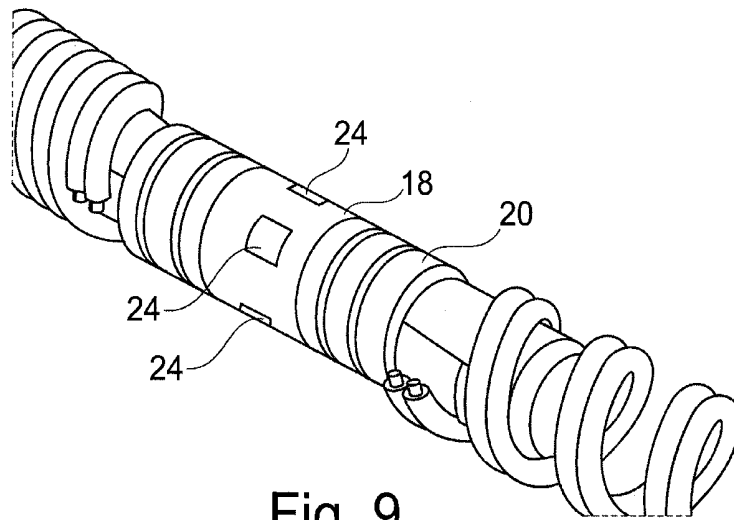

Fig. 9

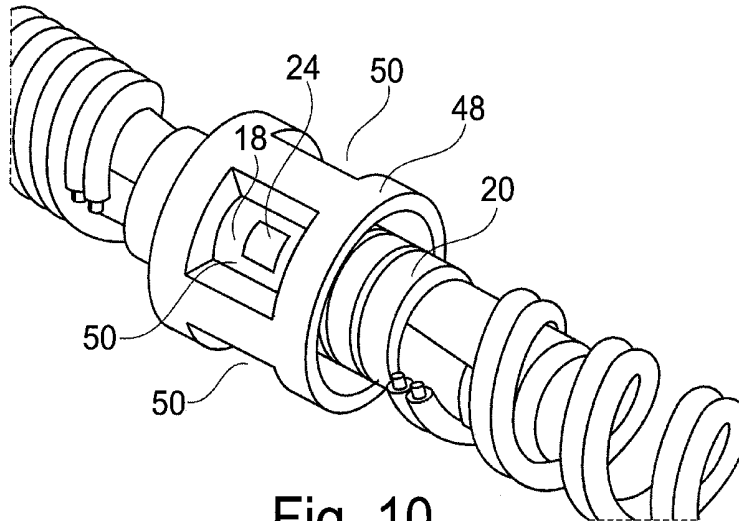

Fig. 10

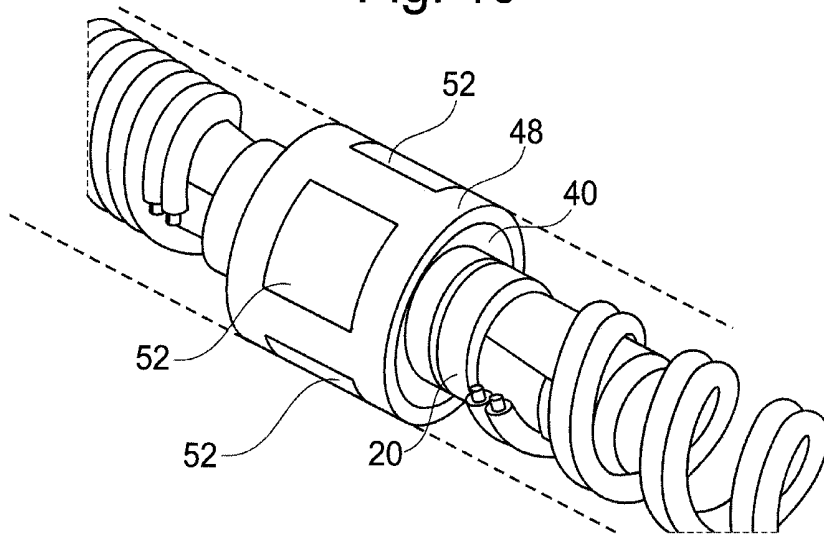

Fig. 11

**LEAD FOR AN ACTIVE IMPLANTABLE
MEDICAL DEVICE WITH A CHIP FOR
ELECTRODE MULTIPLEXING**

CROSS-REFERENCE TO RELATED PATENT
APPLICATIONS

[0001] This application is a continuation of U.S. application Ser. No. 14/696,064, filed Apr. 24, 2015, which is a continuation of U.S. application Ser. No. 13/325,930, filed Dec. 14, 2011, which claims the benefit of and priority to French Application No. 1060452, filed Dec. 14, 2010, which are hereby incorporated by reference herein in their entireties.

BACKGROUND

[0002] The present invention relates to “medical devices” as defined by the 14 Jun. 1993 Directive 93/42/CE of the Council of the European Communities, and more particularly to “active implantable medical devices” as defined by the 20 Jun. 1990 Directive 90/385/EEC of the Council of the European Communities, including those devices that continuously monitor a patient’s heart rhythm and deliver to the heart, if necessary, electrical pulses for stimulation, resynchronization, cardioversion and/or of defibrillation, as well as neurological devices, drug delivery systems, cochlear implants, implantable biological sensors, and similar devices, and as well as devices for measuring pH or intracorporeal impedance (such as the trans-pulmonary impedance or the intracardiac impedance).

[0003] For the collection or detection (the terms being used interchangeably herein) of signals, and for the delivery of pulses for stimulation, such as for cardiac pacing, active implantable medical devices use electrodes that are incorporated into a lead that is connected to the generator of the device. The generator contains the signal collection circuits and the pulse generator circuits. The electrodes are intended to come into contact with the tissues from which an electrical signal is to be collected, and the tissues to be stimulated, such as the myocardium, nerve, or muscle tissues, as the case may be. In the case of a device for cardiac diagnosis and therapy, these electrodes can be endocardial (placed in a cavity of the myocardium in contact with the wall of the myocardium), epicardial (placed on an outside wall of the myocardium, in particular to define a reference potential, or to apply a shock) or intravascular (implanted, for example, in the coronary sinus artery to a location opposing the wall of the left ventricle).

[0004] A first aspect of the development of these active implantable devices is the increasing number of electrodes, particularly for those devices called “multisite” devices, that allow for choosing between different stimulation/detection sites and optimizing the operation of the device. The increasing number of electrodes can also result from the presence at a same level of the lead of several sector electrodes (which are electrodes specifically directed in a radial direction with respect to the lead, at the stimulation site), with the option to select one or another of these sector electrodes to optimize the delivery of pulses to the selected site. This is particularly true for leads implanted in the coronary venous system, for indirect stimulation of a left cavity: with several sector electrodes, it is relatively easy to choose the one that faces

the wall of the epicardium in front of the cavity and in contact with the wall and thus to avoid phrenic nerve stimulation.

[0005] Another aspect of the development of implantable devices is the integration of different sensors into the lead, especially blood pressure or acceleration sensors, including endocardial acceleration (EA) sensors. The signals collected by these sensors provide information representative of the instantaneous hemodynamic status of the patient, allowing for more effective control of the various functions of the device.

[0006] These lead sensors also require a specific connection for the transmission of signals from the sensor, typically located at the distal end of the lead, to the generator connected at the opposite, proximal end. This connection is specific to the sensor and is superimposed on the specific connections existing between the generator and the various electrodes located in the distal region of the lead.

[0007] In any case, to accommodate as many conductors as there are electrodes would lead to both unacceptable dimensions for the lead and difficulties in manufacturing the lead, especially at the connecting link between the lead at its proximal end and the implantable generator to which it is coupled.

[0008] These developments, therefore, require the introduction of multiplexing electronic circuits to manage the exchange of multiple signals between the lead (electrodes and/or sensors) and the generator, and vice versa. Multiplexing is provided in situ, close to the electrodes by an electronic circuit (hereinafter simply called “chip”) embedded in the distal part of the lead, at or in the vicinity of its end (wherein the signals are collected and/or the pulses are to be delivered).

[0009] The EP 1938861 A1 (US counterpart: US2008/0177343) and EP 2082684 A1 (US counterpart: US2009/0192572) (all commonly owned by Sorin CRM S.A.S., previously known as ELA Medical, of Clamart France) describe such a lead having a plurality of electrodes, for example, ten electrodes, near its distal end associated with a chip, hermetically encapsulated in the vicinity of the electrodes in a rigid ring, providing the multiplexing/demultiplexing of the electrodes with a common bus formed by two insulated conductors extending along the entire length of the lead to the proximal connector, allowing the coupling with the generator, the latter being equipped with a counterpart demultiplexing/multiplexing circuit.

[0010] WO2010/091435 A2 and WO 2006/069322 A2 (Proteus Biomedical, Inc.) describe a system in which a common two-wire bus transmits signals from/to sector-addressable electrodes formed on “satellites” located on the lead at regular intervals. A multiplexing/demultiplexing chip is mounted inside the lead, and connected to the wires of the bus by means of welded micro-springs. The construction described, however, only leaves the lead with an internal lumen having a very small internal diameter relative to its outside diameter, due to the size of the chip and connections to the wires. This constraint limits the application of this technique to electrodes located at the distal end of lead, because the small lumen diameter would not allow the use of traditional techniques of implantation, unless by greatly increasing the outer diameter of the lead at the location of the those distal electrodes, which would in turn limit the

applications. In addition, the implementation technology is extremely difficult to implement and its reliability over time has not been proven.

SUMMARY

[0011] It is, therefore, an object of the present invention to provide a lead having an internal lumen with a diameter comparable to that of the currently existing leads (typically having an inner diameter of 0.55 mm or 1.65 French), and electrical insulation over conductors and the chip.

[0012] It is another object of the present invention to provide a such lead with an outer diameter comparable to currently existing leads (typically an external diameter of 1.6 mm or 4.8 French or even 4 French), with a relatively constant diameter along the length of the lead, namely a lead configuration known as “monodiameter.”

[0013] It is a further object of the present invention to provide such a lead with a chip natively encapsulated thanks to the geometry and configuration of the elements of the lead, with excellent electrical insulation and mechanical protection against both torsional stress and bending.

[0014] The present invention is directed to a lead of the above known type, for example as disclosed in the WO 2010/091435 A2 cited above, comprising: an elongated flexible sheath with a central lumen; at least one conductive connection housed in the lumen of the sheath; a rigid cylindrical supporting tube in an isolating material, with a crossing central bore, the supporting tube being interposed in the sheath, namely, being inserted in the sheath so that its crossing bore is coaxial (i.e., in axial alignment) with the lumen of the sheath, the supporting tube including in its surface a cavity forming a receptacle for a chip, opening into a central region of the supporting tube; at least one electrode provided on the sheath surface; and at least one electronic circuit on a substrate comprising a chip, and at least two conductive pads respectively connected to the conductive connection and to the electrode, the chip having an outer conductive pad on one side of the substrate and on the opposite side an inner conductive pad, the electrode being electrically connected to the outer conductive pad of the chip; and a feedthrough conductor connected in a central region to the inner conductive pad of the chip.

[0015] Preferably, the substrate of the chip is a flexible substrate, disposed with a curved conformation in the receptacle of the supporting tube. In one embodiment, the conductive connection housed by the sheath includes a disconnect at the supporting tube location, and the feedthrough conductor is a conductive strip formed at the surface of the supporting tube, extending in the axial direction throughout the supporting tube, and connected at both ends face-to-face with the conductive connection housed in the sheath. Preferably, the electrode is for signal collection and/or pulse delivery, and more particularly is for cardiac sensing/pacing.

[0016] In another embodiment, the chip has a flexible substrate with an outer conductive area on one side of the substrate and an inner conductive pad on the opposite side, and is disposed with a bent conformation in the receptacle of the supporting tube. Preferably, a sensing/pacing electrode is carried by the supporting tube and is electrically connected to the exterior conductive pad of the chip. As for the conductive strip, it is preferably connected (i) at each end face to face to the conductive connection(s) housed in the sheath, and (ii) in a central region, to the inner conductive area of the chip.

[0017] In one embodiment, the insulating material of the supporting tube is a ceramic. Preferably, the lead has a unique ring electrode the shape of which is a conductive sleeve circumferentially extending around the entire periphery of the supporting tube and slipped over the central region of the supporting tube.

[0018] In one embodiment, the lead has a plurality of sector electrodes isolated from each other, circumferentially distributed around the perimeter of the supporting tube and each connected to a corresponding plurality of conductive pads outside of the chip.

[0019] Preferably, the overall diameter of the lead is essentially constant in the region of the supporting tube and of the electrode, and equal to the diameter of the flexible sheath.

[0020] In a preferred embodiment, the lead has two separate conductive connections housed in the lumen of the sheath, the supporting tube including two corresponding crossing separate conductive strips that are isolated from each other and more preferably formed in diametrically opposed regions on the surface of the supporting tube.

[0021] Advantageously, the present invention results in a lead offering the practitioner a conventional lead configuration, allowing for its implantation using, and without changing, the normal implantation techniques. Also advantageously, the present invention provides a lead that can be manufactured by implementation of standard processes in the manufacture of leads, that is to say proven processes that can be implemented at lower cost.

BRIEF DESCRIPTION OF THE DRAWINGS

[0022] Further features, characteristics, and advantages of the present invention will become apparent to a person of ordinary skill in the art from the following detailed description of embodiments of the present invention, made with reference to the annexed drawings, in which like reference characters refer to like elements, and in which:

[0023] FIGS. 1-8 show the successive steps for manufacturing the section of a first embodiment of the lead including the chip and at least one electrode, with its various components, according to the present invention, with FIG. 1 illustrating a supporting tube before receiving a flexible chip, FIG. 2 illustrating a partial cutaway view of the supporting tube of FIG. 1, FIG. 3 illustrating a partial cutaway view of the supporting tube of FIG. 2 after installation of a flexible chip, FIG. 4 illustrating the supporting tube of FIG. 3 after installation of a conductive sleeve, FIG. 5 illustrating the supporting tube of FIG. 4 after sealing the assembly against the external environment, FIGS. 6 and 7 illustrating the supporting tube of FIG. 5 after being welded to the conductive connection, and FIG. 8 showing a cutaway view of the relevant portion of the lead in its finished state; and

[0024] FIGS. 9 to 11 show the successive steps for manufacturing the section of a second embodiment of the lead including the chip and several sector electrodes, in which FIG. 9 illustrates a supporting tube for supporting a sector electrode, FIG. 10 illustrates the supporting tube of FIG. 9 after installation of an insulating sleeve, and FIG. 11 illustrates the supporting tube of FIG. 10 after installation of the sector electrodes.

DETAILED DESCRIPTION

[0025] With reference to the drawings, preferred embodiments of the present invention will now be described.

[0026] With reference to FIG. 8, a portion of a lead in accordance with a first embodiment of the present invention is illustrated with its various components, as obtained after execution of the various manufacturing steps illustrated in FIGS. 1 to 7. Reference 10 generally designates the body of a known lead used for cardiac detection/stimulation, for which only a portion is shown (FIGS. 1-8), which portion is generally located near the distal end, including an electrode, e.g., a detection and/or stimulation electrode. The electrode is illustrated as an annular electrode in the first embodiment shown in FIGS. 1-8. The electrode is illustrated as a plurality of sector electrodes in the second embodiment shown FIGS. 9-11 (described further below).

[0027] Lead 10 also includes two conductive connections in the form of individually isolated coiled wires, each of the two connections preferably being, for example, a respective pair of conductors 12, 12 and 14, 14. These conductive connections run along the entire length of the lead and are connected at the proximal end of the lead to a coupling connector to a generator implant (not shown). Lead 10 also carries a ring electrode 16 connected to a chip 18 providing the multiplexing/demultiplexing functions (as well as to other electrodes located in other parts of the lead) with conductive connections 12, 14 acting as a connection bus between the various electrodes of lead 10 and a remote generator (not shown).

[0028] Chip 18 is electrically connected, on the one hand, to electrode 16 and, the other hand, to each of conductive connections 12 and 14.

[0029] For convenience and simplicity of the description of a preferred embodiment of the present invention, chip 18 is described here as a multiplexer/demultiplexer of electrode (s), but a person of ordinary skill in the art would understand that the present invention is not limited to this exemplary type of circuit and that chip 18 also or in the alternative may be coupled to a sensor (e.g., a signal transducer that produces an electrical signal representative of the changes of a physical parameter being monitored by the sensor). In this regard, in one embodiment chip 18 may incorporate such a sensor, or include an active electronic circuit such as an amplifier, or filter, with or without a sensor placed nearby, or a micro-electromechanical (MEMS) device, or generally, any active element that may be technologically integrated into a lead body. As contrasted with the structure and electrical interconnections, the multiplexing/demultiplexing, switching, and any signal processing functions of chip 18 form no part of the present inventions.

[0030] Chip 18 in this embodiment has two outputs corresponding to conductive connections 12 and 14 of the wire bus, and a third output for connection to electrode 16, and possibly additional outputs in the case, for example, of a multi-electrode configuration (as in the case of FIGS. 9 to 11 described below, comprising a plurality of sector electrodes multiplexed by a single chip).

[0031] Preferably, chip 18 is mounted on a rigid cylindrical supporting tube 20 made of an insulating material and having a central crossing bore 22 ensuring, with no reduction in diameter, the continuity of the inner lumen of the lead, necessary, for example, for the passage of a stylet or a grommet during an implantation procedure (see FIGS. 1 and 3).

[0032] To allow mounting on the cylindrical supporting tube, chip 18 preferably has a flexible substrate, meaning that the substrate is thin enough to be bent and to fit to the cylindrical surface of the substrate. This technique is, for example, described by Zimmermann et al., *A Seamless Ultra-Thin Chip Fabrication and Assembly Process*, Electron Devices Meeting IEDM '06, 11-13 Dec. 2006, pp. 1-3, to which one skilled in the art is referred and which disclosure is hereby incorporated herein by reference. To make chip 18 flexible, it is necessary to thin the substrate (usually a silicon substrate) to a thickness of less than 0.1 mm, so that it can match the shape of tube 20, whose outside diameter is, in the illustrated example, 0.85 mm, where chip 18 is located.

[0033] With particular reference to FIG. 3, chip 18 has on an outer (convex) surface on which is located an outer conductive pad 24. Pad 24 is intended to come into contact with electrode 16 (see FIG. 8), and it carries at its opposite (concave) outer surface two internal diametrically opposed conductive pads 26 (only one of pads 26 is visible in the FIGS. 3, 4, and 6-8), intended to be connected, as described below, respectively to conductive connections 12 and 14. These various conductive pads comprise, for example, an alloy of gold that can be soldered by reflow at 450° C. to establish the electrical connections required with the elements just mentioned.

[0034] FIGS. 1 and 2 show, separately, supporting tube 20 before it receives flexible chip 18 (FIG. 2 is a cutaway view of FIG. 1 showing in section the internal structure of the tube). Tube 20 is a tube made of an electrically insulating material, preferably constructed by overmolding plastic or ceramic components assembled together by high temperature reflow or by gluing. It has two elongated conductive strips 28, preferably diametrically opposed (one of these strips is visible in the figures) formed on the surface and extending in an axial direction along most of the length of tube 20 to form a crossing, with an apparent central region 28a and two end regions 28b.

[0035] Supporting tube 20 comprises a central region 30 of a greater diameter, e.g., 1 mm in the example shown, provided in its surface with a cavity 32 forming a receptacle for flexible chip 18. The depth of cavity 32 substantially corresponds to the thickness of chip 18 so that once chip 18 is established in cavity 32, it is essentially flush with the contour of cavity 32 (as shown in FIG. 3). The configuration of tube 20 is such that central part 28a of crossing strip 28 is visible, i.e., exposed, at the bottom of cavity 32.

[0036] Supporting tube 20 also has two end regions 34 of a smaller diameter, e.g., 0.85 mm in the example shown, with two respective ends 28b of crossing conductive strip 28. The length of tube 20 is, in this example, about 5 mm and the surface area of cavity 32 is about 1 to 2 mm².

[0037] It should be understood that central bore 22 is completely electrically isolated from crossing strips 28 and from cavity 32, with a wall thickness 36 (as shown in FIG. 2) of supporting tube 20 of about 0.55 mm. This structure helps maintain the electrical isolation while maintaining a relatively large bore diameter.

[0038] FIG. 3 illustrates the supporting tube after installation of chip 18 in cavity 32.

[0039] The next step in the manufacturing process, illustrated in FIG. 4, is to put on the assembly a previously obtained sleeve 38 made of a conductive material, fitted to central region 30 of supporting tube 20 and based on the full

extent in the axial direction of cavity 32, so that sleeve 38 covers the entire surface of chip 18. A thermal reflow step establishes an electrical connection between each of internal conductive pads 26 of chip 18 and central part 28a of crossing conductive strip 28, thus ensuring electrical continuity between each of these pads and both ends 28b at ends 34 of supporting tube 20. This heating also allows establishing electrical contact between external pad 24 of chip 18 and the conductive material of sleeve 38, for constituting ring electrode 16.

[0040] The next step, illustrated in FIG. 5, is to complete the sealing of the assembly with respect to the external environment, by injecting a mass of material 40, such as polyurethane glue, in the space between sleeve 38 and central region 30 of supporting tube 20. In addition to sealing, the mass of glue protects the assembly, including chip 18, in respect of all the constraints and external mechanical stresses, thus ensuring a sustainable and protective encapsulation of the assembly of electrical and electronic components, including during the assembly of lead 10 at the factory.

[0041] At this stage, the resulting assembly is ready for a visual inspection and an electrical test of chip 18 functionalities, prior to assembly of the lead body that will now be described.

[0042] The next step, shown in FIG. 6, is to establish electrical connections formed by spiral conductors 12, 12 and 14, 14 and to weld these conductors to corresponding pads 28b, for example by a weld 42, 42 between the stripped end of conductors 12, 12 and end pad 28b at the proximal side of the crossing conductive strip located there. Welding is preferably performed by laser welding, and forms no part of the present invention. The same welding step is performed in the diametrically opposite region (not shown in the figure) between conductors 14, 14 of the other electrical connection and the other crossing conductive strip diametrically opposed to that illustrated in FIG. 6.

[0043] The next step, illustrated in FIG. 7, is to do the same on the opposite side of annular sleeve 38, i.e., on the distal side, for example by a laser formed weld 44, 44 joining conductors 12, 12 on end 28b at the distal side of crossing conductive strip 28 (and similarly for conductors 14, 14 in the diametrically opposed region).

[0044] Once welds 42, 42, and 44, 44 are made, the electrical continuity of conductive connections 12, 12 and 14, 14 is provided on both sides of sleeve 38. Furthermore, a connection is established, as explained with reference to FIG. 4, with each of these connections and the corresponding interior pad of chip 18, for example, as illustrated, between connection 12, 12 and interior pad 26.

[0045] The final step, illustrated in FIG. 8, is to coat or cover spiral conductors 12, 12 and 14, 14 on either side of sleeve 38 with a cylindrical isolated sheath 46, for example, made of polyurethane or silicone, having an essentially constant diameter identical to that of sleeve 38. This provides a monodiameter lead, having a typical outer diameter of 1.6 mm (4.8 French), and provided with an internal lumen 22 of at least 0.55 mm (also the diameter of the central crossing bore of supporting tube 20), similar to conventional leads, such as a Xfine TX26D lead manufactured by Sorin CRM, Clamart, France.

[0046] By providing one or more supporting tubes 20 interposed between conductor sleeves 38 as successive annular electrodes, it is possible to manufacture a lead

comprising at different locations along its length a plurality of electrodes, all multiplexed through a respective corresponding chip disposed underneath the electrode.

[0047] With reference to FIGS. 9-11, a second embodiment of the present invention is illustrated in which conductive sleeve 38 forming annular electrode 16 of the first embodiment described above is replaced by an insulating sleeve 48 of the same diameter, but provided with a plurality of cavities 50, for example, four axially oriented cavities 50, each revealing a conductive pad 24 outside of chip 18. This is realized, instead of a single ring electrode, by a plurality of sector electrodes, for example, oriented in four quadrants, these electrodes being selectable at will by a multiplexing system integrated into chip 18. The latter is provided with a plurality of external conductive pads 24, preferably equal in number to the plurality of sector electrodes, these pads being still visible in the bottom of cavities 50 of sleeve 48 after insertion of sleeve 48 on supporting tube 20 (see FIG. 10).

[0048] Sector electrodes 52 are preferably formed by clipping a conductor micromechanical component coming into contact with outer conductive pad 24 of chip 18 and the outer surface of which (which is flush with cylindrical sleeve 48) is the sector electrode itself.

[0049] It will be understood by a person of ordinary skill in the art that it is relatively easy to adjust the surface and shape of each sector electrode 50, simply by defining as desired the size and shape of the cavities 50 of insulating sleeve 48.

[0050] One skilled in the art will understand the present invention is not limited by, and may be practiced by other than the foregoing embodiments described, which are presented for purposes of illustration and not of limitation.

What is claimed is:

1. A method of manufacturing a lead for an active implantable medical device, comprising:

providing a supporting tube;

disposing a conductive strip on an outer surface of the supporting tube such that the conductive strip extends in an axial direction along a length of the supporting tube;

mounting a chip including a first conductive contact pad and a second conductive contact pad to the supporting tube such that the first conductive contact pad is in contact with the conductive strip;

fitting an electrode to the supporting tube such that the electrode is in contact with the second conductive contact pad;

coupling a conductor to each end of the supporting tube such that each conductor is in contact with the conductive strip; and

covering at least one of the chip and the conductors with a sheath to provide the lead.

2. The method of claim 1, further comprising separating the sheath into two or more segments by interposing the supporting tube in the sheath, the two or more segments comprising a first segment and a second segment.

3. The method of claim 1, wherein the supporting tube comprises a central region and two end regions, wherein the central region has a diameter that is greater than a diameter of the two end regions.

4. The method of claim 3, further comprising forming a cavity within the central region of the supporting tube, the cavity forming a chip receptacle configured to hold the chip.

5. The method of claim 4, further comprising forming the cavity such that a depth of the cavity corresponds with a thickness of the chip such that the exterior surface of the chip is flush with the diameter of the central region of the supporting tube when the chip is held in the cavity.

6. The method of claim 4, further comprising forming the chip with a flexible substrate such that an interior surface of the chip is formed to an outer surface of the supporting tube when the chip is held in the chip receptacle.

7. The method of claim 1, further comprising extending a conductive sleeve circumferentially around a periphery of the central region of the supporting tube.

8. The method of claim 7, further comprising structuring the conductive sleeve such that the conductive sleeve contacts the first conductive contact pad of the chip when the chip is mounted on the supporting tube.

9. The method of claim 7, further comprising heating the conductive sleeve onto the supporting tube via thermal reflow to establish electrical continuity.

10. The method of claim 7, further comprising injecting a mass of material in a space between the conductive sleeve and the central region of the supporting tube.

11. The method of claim 10, wherein the mass of material comprises a polyurethane glue.

12. The method of claim 1, wherein the first conductive contact pad is positioned on an exterior surface of a substrate of the chip and the second conductive contact pad is positioned on an interior surface of the substrate of the chip.

13. The method of claim 1, wherein the conductive strip is a first conductive strip, the method further comprising disposing a second conductive strip on the outer surface of the supporting tube, wherein the first conductive strip and the second conductive strip are disposed on diametrically opposed regions of the supporting tube.

14. The method of claim 1, further comprising defining a plurality of cavities by circumferentially extending an insulating sleeve around a periphery of the central region of the supporting tube, wherein the electrode comprises a plurality of sector electrodes, one of each of the plurality of sector electrodes disposed with each of the plurality of cavities, wherein the first conductive contact pad comprises a plu-

rality of first conductive contact pads, and wherein each of the plurality of sector electrodes is connected to a corresponding one of the plurality of first conductive contact pads of the chip.

15. The method of claim 1, further comprising forming the supporting tube of at least one of a ceramic material and a plastic material to electrically isolate the supporting tube.

16. A method of manufacturing a supporting tube of a lead for an active implantable medical device, comprising:

providing a supporting tube;

disposing a conductive strip on an outer surface of the supporting tube such that the conductive strip extends in an axial direction along a length of the supporting tube;

mounting a chip including a first conductive contact pad and a second conductive contact pad to the supporting tube such that the first conductive contact pad is in contact with the conductive strip;

fitting an electrode to the supporting tube such that the electrode is in contact with the second conductive contact pad; and

coupling a conductor to each end of the supporting tube such that each conductor is in contact with the conductive strip.

17. The method of claim 16, further comprising extending a conductive sleeve configured as an electrode circumferentially around a periphery of a central region of the supporting tube.

18. The method of claim 17, further comprising forming a cavity within the central region of the supporting tube, the cavity forming a chip receptacle configured to hold the chip.

19. The method of claim 18, further comprising forming the cavity such that a depth of the cavity corresponds with a thickness of the chip such that the exterior surface of the chip is flush with the diameter of the central region of the supporting tube when the chip is held in the cavity.

20. The method of claim 19, further comprising forming the chip with a flexible substrate such that an interior surface of the chip is formed to an outer surface of the supporting tube when the chip is held in the chip receptacle.

* * * * *

专利名称(译)	带有电极多路复用芯片的有源植入式医疗设备的引线		
公开(公告)号	US20190167138A1	公开(公告)日	2019-06-06
申请号	US16/252279	申请日	2019-01-18
申请(专利权)人(译)	索林CRM SAS		
当前申请(专利权)人(译)	索林CRM SAS		
[标]发明人	OLLIVIER JEAN FRANCOIS		
发明人	OLLIVIER, JEAN-FRANCOIS		
IPC分类号	A61B5/0408 A61B5/0215 A61B5/00 A61N1/05 H01R43/20		
CPC分类号	A61B5/0408 A61B5/0215 A61B5/686 A61N1/0587 H01R43/20 A61N1/05 Y10T29/49171 Y10S439/909 A61B2562/125		
优先权	2010060452 2010-12-14 FR		
外部链接	Espacenet USPTO		

摘要(译)

一种用于有源可植入医疗装置的引线，包括芯片，特别是用于电极多路复用。引线包括插入柔性细长管中的绝缘支撑管，其中心孔与引线的内腔同轴。支撑管在其表面上包括至少一个沿轴向延伸的交叉导电条。柔性基板上的芯片设置成在与导电条隔离的支撑管的容器中具有弯曲或弯曲的构造。由支撑管承载的例如用于心脏感测/起搏的电极电连接到芯片的外导电垫。导电条在每个端部处 (i) 面对面地连接到容纳在护套中的导电连接，并且 (ii) 在中心区域中连接到芯片的内部导电垫。

