



US 20170361042A1

(19) **United States**

(12) **Patent Application Publication**
Klein et al.

(10) **Pub. No.: US 2017/0361042 A1**
(43) **Pub. Date: Dec. 21, 2017**

(54) **APPARATUS TO ATTAIN AND MAINTAIN TARGET END TIDAL PARTIAL PRESSURE OF A GAS**

(71) Applicants: **Michael Klein**, Toronto (CA); **Joseph Fisher**, Thornhill (CA); **James Duffin**, Toronto (CA); **Marat Slessarev**, Toronto (CA); **Cathie Kessler**, Toronto (CA); **Shoji Ito**, Nagoya (JP)

(72) Inventors: **Michael Klein**, Toronto (CA); **Joseph Fisher**, Thornhill (CA); **James Duffin**, Toronto (CA); **Marat Slessarev**, Toronto (CA); **Cathie Kessler**, Toronto (CA); **Shoji Ito**, Nagoya (JP)

(21) Appl. No.: **15/585,999**

(22) Filed: **May 3, 2017**

Related U.S. Application Data

- (63) Continuation of application No. 14/363,259, filed on Jun. 5, 2014, now abandoned, filed as application No. PCT/CA2012/001123 on Dec. 5, 2012.
- (60) Provisional application No. 61/566,997, filed on Dec. 5, 2011.

Publication Classification

- (51) **Int. Cl.**
- A61M 16/00* (2006.01)
 - A61B 5/00* (2006.01)
 - A61M 16/10* (2006.01)
 - A61B 5/083* (2006.01)
 - A61M 16/12* (2006.01)
 - A61M 16/08* (2006.01)

- (52) **U.S. Cl.**
- CPC *A61M 16/0051* (2013.01); *A61M 16/12* (2013.01); *A61M 16/0069* (2014.02); *A61M 16/0883* (2014.02); *A61M 16/1005* (2014.02); *A61M 16/122* (2014.02); *A61B 5/083* (2013.01); *A61B 5/0833* (2013.01); *A61B 5/0836* (2013.01); *A61B 5/4836* (2013.01); *A61M 16/0003* (2014.02); *A61M 16/085* (2014.02); *A61M 2016/0021* (2013.01); *A61M 2016/0027* (2013.01); *A61M 2016/102* (2013.01); *A61M 2230/435* (2013.01); *A61M 2016/103* (2013.01); *A61M 2205/502* (2013.01); *A61M 2230/43* (2013.01); *A61M 2230/432* (2013.01); *A61M 2016/1025* (2013.01)

(57) **ABSTRACT**

A processor obtains input of a logistically attainable end tidal partial pressure of gas X ($P_{etX}[i]^T$) for one or more respective breaths [i] and input of a prospective computation of an amount of gas X required to be inspired by the subject in an inspired gas to target the $P_{etX}[i]^T$ for a respective breath [i] using inputs required to utilize a mass balance relationship, wherein one or more values required to control the amount of gas X in a volume of gas delivered to the subject is output from an expression of the mass balance relationship. The mass balance relationship is expressed in a form which takes into account (prospectively), for a respective breath [i], the amount of gas X in the capillaries surrounding the alveoli and the amount of gas X in the alveoli, optionally based on a model of the lung which accounts for those sub-volumes of gas in the lung which substantially affect the alveolar gas X concentration affecting mass transfer.

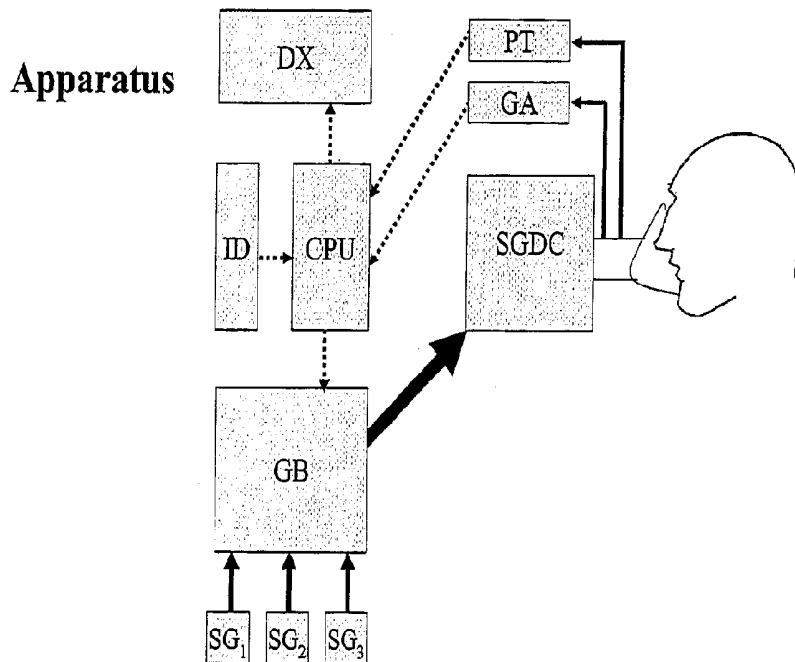

Figure 1
Overall system

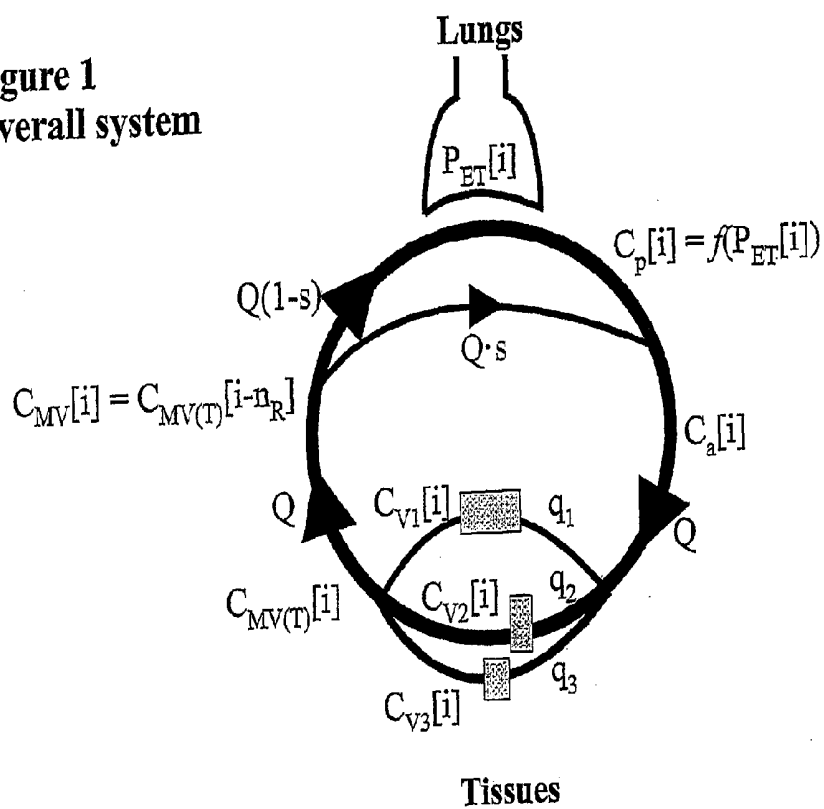
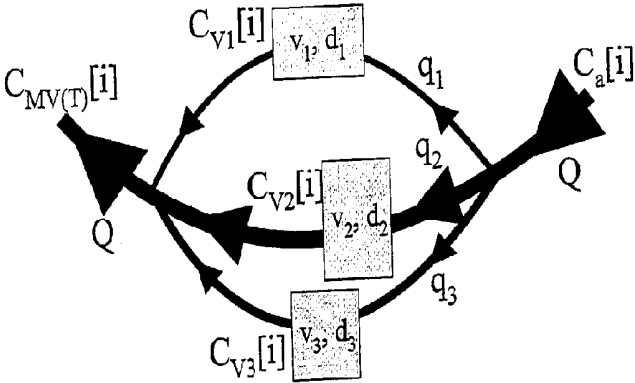

Figure 2
The Tissues



$$P_{ET}X[i]^T = \frac{\underbrace{P_{ET}X[i-1]^T \cdot FRC}_{\text{gas X in FRC}} + \underbrace{P_{ET}X[i-1]^T \cdot V_D}_{\text{gas X re-inspired from } V_D} + \underbrace{P_T X[i] \cdot (V_T - V_D)}_{\text{gas X in controlled gas mixture}} + \underbrace{PB \cdot Q \cdot (1-s) \cdot T_R \cdot (C_{MP} X[i] - C_P X[i])}_{\text{gas X transferred into lung from the circulation (VB}_x)}$$

$$P_{ET}X[i]^T = \frac{V_T + FRC}{V_T + FRC} \cdot \left[\dots \right]$$

Total volume of the alveolar space

Figure 3
Lung No SGD

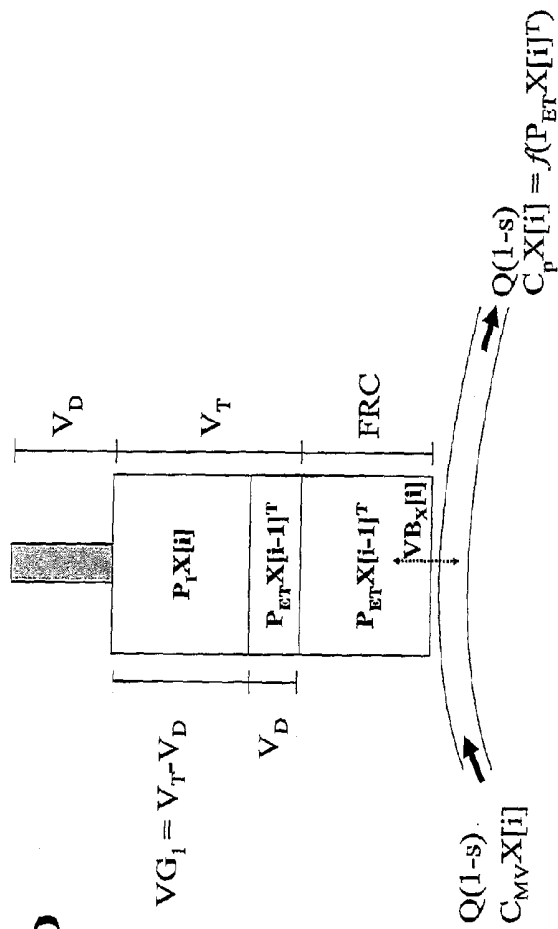

$$P_{ET} X[i]^T = \underbrace{P_{ET} X[i-1]^T \cdot FRC + P_{ET} X[i-1]^T \cdot V_D}_{\text{gas X in FRC}} + \underbrace{P_T X[i] \cdot (FG_1 \cdot T_B) + P_{ET} X[i-1]^T \cdot (V_T - V_D - FG_1 \cdot T_B)}_{\text{gas X in neutral gas}} + \underbrace{P_B \cdot Q \cdot (1-s) \cdot T_B \cdot (C_{MV} X[i] - C_p X[i])}_{\text{gas X transferred into lung from the circulation (VB_X)}}$$

$$V_T + FRC$$

Total volume of the alveolar space

Figure 4
Lung SGD

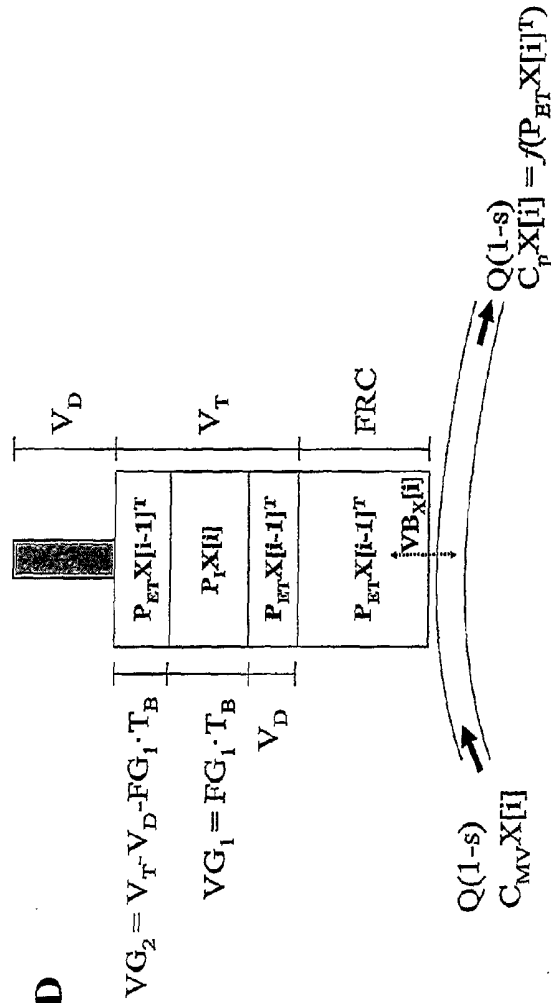

Figure 5
Apparatus

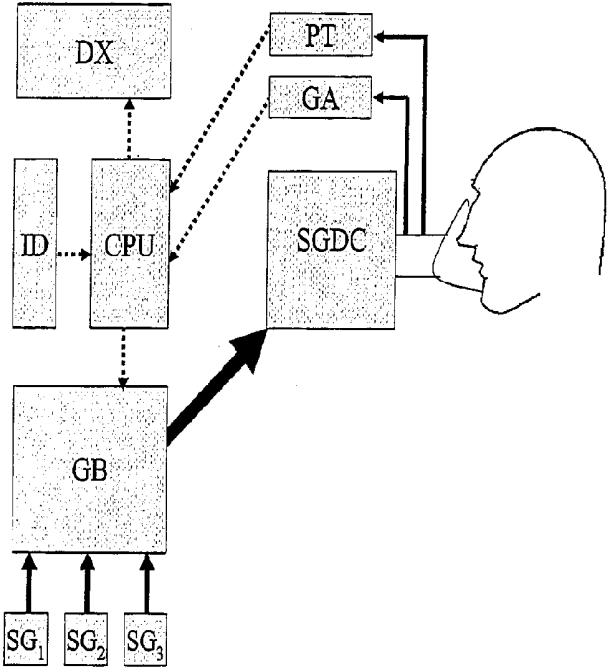

Figure 6
Tuning

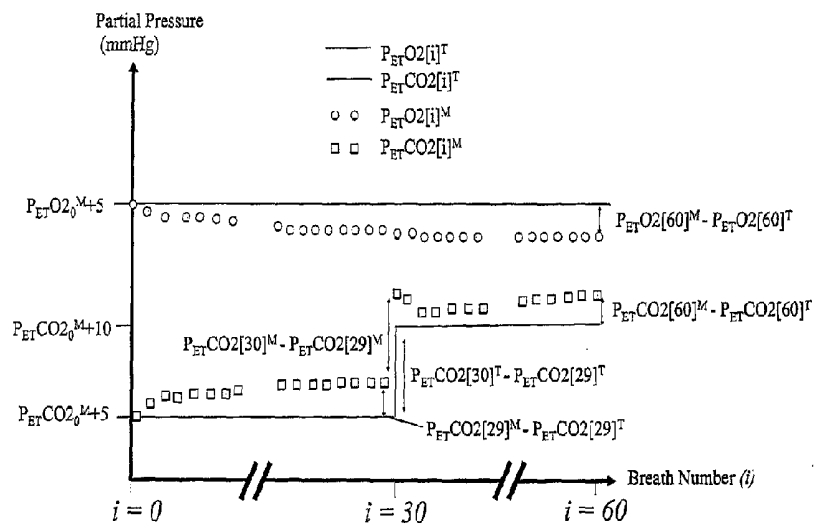

Figure 7

Definitions of abbreviated terms

Term	Units	Definition
n		Total number of breaths in the target sequence
i		Index of breath number in the target sequence
$P_{ET}O_2[i]^T$	mmHg	Target end-tidal partial pressure of O ₂ during breath i
$P_{ET}CO_2[i]^T$	mmHg	Target end-tidal partial pressure of CO ₂ during breath i
$P_{ET}O_2[i]^M$	mmHg	Measured end-tidal partial pressure of O ₂ during breath i
$P_{ET}CO_2[i]^M$	mmHg	Measured end-tidal partial pressure of CO ₂ during breath i
$pH[i]$		pH of pulmonary end-capillary blood during breath i
$[HCO_3]$	mmol/L	Bicarbonate concentration of the blood throughout the circulation
$P_pO_2[i]$	mmHg	Partial pressure of O ₂ in the pulmonary end-capillary blood during breath i
$P_pCO_2[i]$	mmHg	Partial pressure of CO ₂ in the pulmonary end-capillary blood during breath i
T	C	Body temperature
$S_pO_2[i]$	%	O ₂ saturation of the pulmonary end-capillary blood during breath i
Hb	g/dL	Concentration of haemoglobin in the blood throughout the circulation
$C_pO_2[i]$	ml/dL	O ₂ content of the pulmonary end-capillary blood during breath i
$C_pCO_2[i]$	ml/dL	CO ₂ content of the pulmonary end-capillary blood during breath i

Figure 7 – (continued)

$C_aO_2[i]$	ml/dL	O2 content of the arterial blood during breath i
$C_aCO_2[i]$	ml/dL	CO2 content of the arterial blood during breath i
$C_{MV(T)}O_2[i]$	ml/dL	O2 content of the mixed-venous blood leaving the tissues during breath i
$C_{MV(T)}CO_2[i]$	ml/dL	CO2 content of the mixed-venous blood leaving the tissues during breath i
$C_{MV}O_2[i]$	ml/dL	O2 content of the mixed-venous blood entering the pulmonary circulation during breath i
$C_{MV}CO_2[i]$	ml/dL	CO2 content of the mixed-venous blood entering the pulmonary circulation during during breath i
s	%/100	Intrapulmonary shunt fraction
Q	dL/min	Cardiac output
T_B	min	Breath period
VO_2	ml/min	Overall metabolic consumption of O2
VCO_2	ml/min	Overall metabolic production of CO2
n_{O_2}		Total number of compartments in the model of O2 in the tissues
j		Index of the compartments in the model of O2 in the tissues
vo_{2j}	%/100	Fraction of the overall metabolic consumption of O2 assigned to compartment j of the model of O2 in the tissues
q_j	%/100	Fraction of the overall cardiac output assigned to compartment j of the model of O2 in the tissues
dO_{2j}	ml	Storage capacity for O2 of compartment j of the model of O2 in the tissues

Figure 7 – (continued)

n_{CO_2}		Total number of compartments in the model of CO ₂ in the tissues
k		Index of the compartments in the model of CO ₂ in the tissues
$v_{CO_2,k}$	%/100	Fraction of the overall metabolic production of CO ₂ assigned to compartment k of the model of CO ₂ in the tissues
q_k	%/100	Fraction of the overall cardiac output assigned to compartment k of the model of CO ₂ in the tissues
$dCO_{2,k}$	ml	Storage capacity for CO ₂ of compartment k of the model of CO ₂ in the tissues
SGDC		Sequential gas delivery circuit
PT		Pressure transducer
GA		O ₂ /CO ₂ gas analyzer
DX		Display
CPU		Computer
ID		Input device
GB		Gas blender
FT		Flow transducer
G_1		The controlled gas mixture inspired by the subject
G_2		Neutral gas inspired by the subject

Figure 7 – (continued)

FG_1	ml/min	Rate at which the controlled gas mixture (G_1) is made available for inspiration
VG_1	ml	Average volume of the controlled gas mixture (G_1) inspired into the alveoli per breath
VG_2	ml	Average volume of neutral gas (G_2) inspired into the alveoli per breath
V_T	ml	Tidal volume
V_D	ml	Anatomical dead space
$P_{iO_2}[i]$	mmHg	Partial pressure of O ₂ in the controlled gas mixture (G_1) during breath i
$P_{iCO_2}[i]$	mmHg	Partial pressure of CO ₂ in the controlled gas mixture (G_1) during breath i
$F_{iO_2}[i]$	%/100	Fractional concentration of O ₂ in the controlled gas mixture (G_1) during breath i
$F_{iCO_2}[i]$	%/100	Fractional concentration of CO ₂ in the controlled gas mixture (G_1) during breath i
FRC	ml	Functional residual capacity
W	kg	Subject weight
H	m	Subject height
A	years	Subject age
G	male/ female	Subject sex
n_R	# breaths	Recirculation time

Figure 7 – (continued)

PB	mmHg	Barometric pressure
n_{SG}		Total number of source gases blended to create the controlled gas mixture
m		Index of source gases blended to create the controlled gas mixture
SG_m		Source gas m blended to create the controlled gas mixture
$FSG_m[i]$	ml/min	Flow rate of source gas m (SG_m) during breath i
$fo2_m$	%/100	Fractional concentration of O2 in source gas m (SG_m)
$fco2_m$	%/100	Fractional concentration of CO2 in source gas m (SG_m)
$P_{ET}O2_0^M$	mmHg	Baseline/resting measured end-tidal partial pressure of O2
$P_{ET}CO2_0^M$	mmHg	Baseline/resting measured end-tidal partial pressure CO2
$VB_{O2}[i]$	ml	The volume of O2 transferred between the alveolar space and the pulmonary circulation during breath i
$VB_{CO2}[i]$	ml	The volume of CO2 transferred between the alveolar space and the pulmonary circulation during breath i
α	ml/mmHg	Correction factor for tuning the estimate of the functional residual capacity (FRC)
β	ml/min/mmHg	Correction factor for tuning the overall metabolic production of O2 ($VO2$)
γ	ml/min/mmHg	Correction factor for tuning the overall metabolic consumption of CO2 ($VCO2$)

Table 2

Starting PCO2 (mm Hg)	1st Baseline (40mmHg)	1st Step (50mmHg)	2nd baseline (40mmHg)	2nd Step (50mmHg)	3rd baseline (40mmHg)	Delta PCO2 First step	Delta PCO2 Second Step
40	40	50	41	50	40	10	9
39	39	49	40	49	40	10	9
41	41	49	42	50	41	8	8
40	39	48.5	40	49	40	9	9
35	39	48	40	48	40	9	8
40	39	48	39	49	40	9	10

Figure 8

APPARATUS TO ATTAIN AND MAINTAIN TARGET END TIDAL PARTIAL PRESSURE OF A GAS

CROSS-REFERENCE TO RELATED APPLICATION

[0001] This application is a continuation of U.S. patent application Ser. No. 14/363,259, filed Jun. 5, 2014, which is a national phase filing, under 35 U.S.C. §371(c), of International Application No. PCT/CA2012/001123, filed Dec. 5, 2012, the disclosures of which are incorporated herein by reference in their entireties. International Application No. PCT/CA2012/001123, in turn, claims the benefit, under 35 U.S.C. §119(e), of U.S. provisional application Ser. No. 61/566,997, filed on Dec. 5, 2011, the disclosure of which is incorporated herein by reference in its entirety.

FIELD OF THE INVENTION

[0002] The present invention relates to an apparatus and method for controlling end tidal gas partial pressures in spontaneously breathing or ventilated subjects and to the use of such an apparatus and method for research, diagnostic and therapeutic purposes.

BACKGROUND OF THE INVENTION

[0003] Techniques for controlling end-tidal partial pressures of carbon dioxide, oxygen and other gases are gaining increasing importance for a variety of research, diagnostic and medicinal purposes. Methods for controlling end tidal pressures of gases have gained particular importance as a means for manipulating arterial levels of carbon dioxide (and also oxygen), for example to provide a controlled vasoactive stimulus to enable the measurement of cerebrovascular reactivity (CVR) e.g. by MRI.

[0004] Conventional methods of manipulating arterial carbon dioxide levels such as breath holding, hyperventilation and inhalation of fixed concentration of carbon dioxide balanced with medical air or oxygen are deficient in their ability to rapidly and accurately attain targeted arterial carbon dioxide partial pressures for the purposes of routinely measuring vascular reactivity in a rapid and reliable manner.

[0005] The end-tidal partial pressures of gases are determined by the gases inspired into the lungs, the mixed venous partial pressures of gases in the pulmonary circulation, and the exchange of gases between the alveolar space and the blood in transit through the pulmonary capillaries. Changes in the end-tidal partial pressures of gases are reflected in the pulmonary end-capillary partial pressures of gases, which in turn flow into the arterial circulation. The gases in the mixed-venous blood are determined by the arterial inflow of gases to the tissues and the exchange of gases between the tissue stores and the blood, while the blood is in transit through the tissue capillary beds.

[0006] Robust control of the end-tidal partial pressures of gases therefore requires precise determination of the gas storage, transport, and exchange dynamics at the lungs and throughout the body. Previous attempts at controlling the end-tidal partial pressures of gases have failed to account for these complex dynamics, and have therefore produced mediocre results.

[0007] In the simplest approaches, manipulation of the end-tidal partial pressures of gases has been attempted with fixed changes to the composition of the inspired gas. How-

ever, without any additional intervention, the end-tidal partial pressures of gases vary slowly and irregularly as exchange occurs at the lungs and tissues. Furthermore, the ventilatory response to perturbations in the end-tidal partial pressures of gases is generally unpredictable and potentially unstable. Often, the ventilatory response acts to restore the condition of the blood to homeostatic norms. Therefore, any changes in the end-tidal partial pressures of gases are immediately challenged by a disruptive response in the alveolar ventilation. Consequently, fixed changes in the inspired gas composition provoke only slow, irregular, and transient changes in blood gas partial pressures.

[0008] In more complex approaches, manipulation of the end-tidal partial pressures of gases has been attempted with negative feedback control. These approaches continuously vary the composition of the inspired gas so as to minimize error between measured and desired end-tidal partial pressures of gases. Technically, such a system suffers from the same limitations as all negative feedback control systems—an inherent trade-off between response time and stability.

[0009] Consequently, there is a need to overcome previous limitations in end-tidal gas control, allowing for more precise and rapid execution of end tidal gas targeting sequences in a wide range of subjects and environments.

SUMMARY OF INVENTION

[0010] The invention is directed to a device and method for controlling an amount of a gas X in a subject's lung to target a targeted end tidal partial pressure of gas X. The device optionally implements the method for more than one gas contemporaneously, for example to control an amount of each of gases X and Y (for example carbon dioxide and oxygen, or oxygen and a medicinal gas) or for example an amount of each of gases X, Y and Z (for example carbon dioxide, oxygen and a medicinal gas) etc. For each particular gas for which this control is sought to be implemented, a prospective determination is made of how much (if any) of the gas in question needs to be delivered by the device in a respective breath [i] to target a logistically attainable target end tidal concentration for the respective breath[i]. A target may be repeated for successive breaths or changed one or multiple times.

[0011] The invention is also directed to a computer program product or IC chip which may be at the heart of the device or method.

[0012] A processor obtains input of a logistically attainable end tidal partial pressure of gas X ($P_{etX}[i]^T$) for one or more respective breaths [i] and input of a prospective computation of an amount of gas X required to be inspired by the subject in an inspired gas to target the $P_{etX}[i]^T$ for a respective breath [i] using inputs required to utilize a mass balance relationship, wherein one or more values required to control the amount of gas X in a volume of gas delivered to the subject is output from an expression of the mass balance relationship. The mass balance relationship is expressed in a form which takes into account (prospectively), for a respective breath [i], the amount of gas X in the capillaries surrounding the alveoli and the amount of gas X in the alveoli, optionally based on a model of the lung which accounts for those sub-volumes of gas in the lung which substantially affect the alveolar gas X concentration affecting mass transfer.

[0013] Based on this prospective determination control of the amount of gas X in a volume of gas delivered to the

subject in a respective breath [i] is implemented to target the respective $P_{etX}[i]^T$ for a breath [i]. Implementing a calibration step as necessary in advance may improve targeting.

[0014] According to one aspect the invention is directed to a method of controlling an amount of at least one gas X in a subject's lung to attain at least one targeted end tidal partial pressure of the at least one gas X, comprising the steps of:

[0015] a. Obtaining input of a logistically attainable end tidal partial pressure of gas X ($P_{etX}[i]^T$) for one or more respective breaths [i];

[0016] b. Obtaining input of a prospective computation of an amount of gas X required to be inspired by the subject in an inspired gas to target the $P_{etX}[i]^T$ for a respective breath [i] using inputs required to compute a mass balance equation, wherein one or more values required to control the amount of gas X in a volume of gas delivered to the subject is output from the mass balance equation; and optionally

[0017] c. Controlling the amount gas X in a volume of gas delivered to the subject in a respective breath [i] to target the respective $P_{etX}[i]^T$ based on the prospective computation.

[0018] According to another aspect the invention is directed to a method of controlling a gas delivery device to control a subject's end tidal partial pressure of a gas X, wherein a signal processor, operatively associated with the gas delivery device, controls the amount of gas X in a volume of inspiratory gas prepared for delivery to the subject in a respective breath [i] using inputs and outputs processed by the signal processor for a respective breath [i], the method comprising:

[0019] a. Obtaining input of one or more values sufficient to compute the concentration of gas X in the mixed venous blood entering the subject's pulmonary circulation for gas exchange in one or more respective breaths [i] ($C_{MV}X[i]$);

[0020] b. Obtaining input of a logistically attainable end tidal partial pressure of gas X ($P_{etX}[i]^T$) for a respective breath [i];

[0021] c. Utilizing a prospective computation sufficient to determine the amount of gas X required to be inspired in a respective breath [i] to target the $P_{etX}[i]^T$ for a respective breath [i], the prospective computation using inputs sufficient to compute a mass balance equation for a respective breath [i], the inputs including values sufficient to determine, for a respective breath [i], $C_{MV}X[i]$ and the concentration of gas X in the subject's alveoli affecting mass transfer (for example $C_{MV}X[i]$ and the concentration or partial pressure of gas X in the alveoli as a result of inspiration in breath [i]);

[0022] d. Outputting control signals to the gas delivery device sufficient to control the amount of gas X in a volume of inspiratory gas set to be delivered to the subject in a respective breath [i] to target the respective $P_{etX}[i]^T$ based on the prospective computation.

[0023] The inventors have found that net mass transfer can be prospectively determined on a breath by breath basis in a manner sufficient to attain a targeted end tidal partial pressure of a gas X, using inputs sufficient to compute $C_{MV}X[i]$ and the concentration of gas X in the subject's lung affecting mass transfer as a result of inspiration in a respective breath [i].

[0024] For present purposes a mass balance equation is understood to be a mathematical relationship that applies the law of conservation of mass (i.e. amounts of gas X) to the analysis of movement of gas X, in and out of the lung, for the purpose of prospectively targeting an end tidal partial pressure of gas X. Optionally, where an end tidal partial pressure of gas X is sought to be changed from a baseline steady state value or controlled for a sequence of respective breaths [i] the mass balance equation will account for the transfer of a mass of gas X between a subject's lung (i.e. in the alveoli) and pulmonary circulation (i.e. the mixed venous blood entering the pulmonary capillaries ($C_{MV}X[i]$)); so that this key source of flux affecting the end tidal partial pressure of gas X in the breath(s) of interest, is accounted for.

[0025] Preferably the mass balance equation is computed based on a tidal model of the lung as described hereafter.

[0026] In one embodiment of the method, a concentration of gas X (F_{IX}), for example in a first inspired gas (the first inspired gas also referred to, in one embodiment of the invention, as a controlled gas mixture) is computed to target or attain $P_{etX}[i]^T$ in a respective breath [i].

[0027] Optionally, the mass balance equation is solved for F_{IX} .

[0028] It will be appreciated that F_{IX} may be output from the mass balance equation by testing iterations of its value without directly solving for F_{IX} .

[0029] Optionally, the volume of gas delivered to the subject is a fixed tidal volume controlled by a ventilator.

[0030] Optionally, the volume of gas delivered to the subject in a respective breath [i] comprises a first inspired gas of known volume and a second inspired neutral gas. Accordingly, according to one aspect, the invention contemplates that controlling the end tidal partial pressure of a gas X based on a prospective method of controlling the amount of gas X inspired by the subject, recognizes that the gas X content of two components of the inspiratory gas (together the "inspired gas") may have to be accounted for, the gas X content of both a first inspired gas and a second inspired gas. As set out in the above-described method, the amount of gas X in a volume of a first inspired gas is controlled by a gas delivery device. As described below, the gas inspired for the remainder of a breath [i] may be a re-breathed gas or a neutral gas of similar composition. For example, the subject may also receive an amount of gas X in the second inspired gas organized for delivery to the subject using a sequential gas delivery (SGD) circuit (described below) which provides the re-breathed gas or a "neutral gas" composed by a gas delivery device. Examples of prospective computations with and without SGD are described below.

[0031] According to one embodiment of a method according to the invention, a signal processor outputs control signals to control the gas X content of a first inspired gas. The total volume of the first inspired gas may be controlled by the signal processor or where the gas delivery device in question is organized to add a gas X source to a pre-existing flow of gas, the gas delivery device may simply control the volume of the added gas but may thereby nevertheless exert overall control of the gas X composition. In this scenario, the gas X content does not have to be varied if the volume of pre-existing flow of gas is varied. Optionally, the role of the gas delivery device contemplated above, is to at least control the gas X composition, and optionally also the total volume of at least a first inspired gas, where there is a second

inspired gas (the term first inspired gas does not necessarily imply an order of delivery and this partial volume of the inspired gas may nevertheless be described herein as “a volume of inspiratory gas”). The control signals may be delivered to one or more flow controllers for delivering variable amounts of gas X. A second inspired gas, if sought to be delivered, may be composed by another gas delivery device (alternatively, both the first inspired gas delivery device and second inspired gas delivery device may be combined in a single device) or the second inspired gas may simply be delivered by a re-breathing or sequential gas delivery circuit as a re-breathed gas of predicted approximate composition.

[0032] In one embodiment of the aforementioned method, a signal processor utilizes a prospective computation sufficient to determine the volume and composition of an inspired gas (i.e. the entirety of the inspired gas or the entirety of the first inspired gas) to target the $PetX[i]^T$ for a respective breath [i], the prospective computation using inputs sufficient to compute a mass balance equation for a respective breath [i], the inputs including values sufficient to determine, for a respective breath [i], $C_{MV}X[i]$ and the concentration or partial pressure of gas X in the alveoli affecting mass transfer as a result of inspiration in breath [i]). Accordingly while the entirety of the inspired gas in a respective breath [i] is accounted for in a mass balance analysis (both first inspired and second inspired (neutral) gas, the control signals output by the signal processor may only control a partial volume and preferably the composition of the first inspired gas.

[0033] In accordance with a tidal model of the lung, in one embodiment of the invention, the mass balance equation is computed in terms of discrete respective breaths [i] including one or more discrete volumes corresponding to a subject's FRC, anatomic dead space, a volume of gas transferred between the subject's lung and pulmonary circulation in the respective breath [i] and an individual tidal volume of the respective breath [i].

[0034] According to another aspect, the invention is directed to a method of controlling an amount of at least one gas X in a subject's lung to attain a targeted end tidal partial pressure of the at least one gas X, comprising:

[0035] a. Obtaining input of a concentration of gas X in the mixed venous blood entering the subject's pulmonary circulation for gas exchange in one or more respective breaths [i] ($C_{MV}X[i]$);

[0036] b. Obtaining input of a logistically attainable end tidal partial pressure of gas X ($PetX[i]^T$) for a respective breath [i];

[0037] c. Obtaining input of a prospective computation of an amount of gas X required to be inspired by the subject in an inspired gas to target the $PetX[i]^T$ for a respective breath [i] using inputs required to compute a mass balance equation including $C_{MV}X[i]$ and values sufficient to compute the contribution of one or more discrete volumetric components of breath [i] to the concentration of gas X in the alveoli, wherein one or more values required to control the amount of gas X in a volume of gas delivered to the subject is output from the mass balance equation; and optionally

[0038] d. Controlling the amount gas X in a volume of gas delivered to the subject in a respective breath [i] to target the respective $PetX[i]^T$ based on the prospective computation.

[0039] In one embodiment of the method, a concentration of gas X ($F_I X$) is computed to target or attain $PetX[i]^T$ in a respective breath [i].

[0040] Optionally, the mass balance equation is solved for $F_I X$.

[0041] In accordance with a tidal model of the lung, in one embodiment of the invention, the mass balance equation is computed in terms of discrete respective breaths [i] including one or more discrete volumes corresponding to a subject's FRC, anatomic dead space, a volume of gas transferred between the subject's lung and pulmonary circulation in the respective breath [i] and an individual tidal volume of the respective breath [i].

[0042] According to another embodiment of the method, the method comprises the step of tuning one or more inputs required for computation of $F_I X$, for example, with respect to any terms and/or by any methods described in this application.

[0043] According to another embodiment of the method, the volume of inspired gas entering the subject's alveoli is controlled by fixing a tidal volume of an inspired gas containing gas X using a ventilator and subtracting a volume of gas corresponding to an estimated or measured value for the subject's anatomic dead space volume.

[0044] According to another embodiment of the method, the gas inspired by the subject is inspired via a sequential gas delivery circuit (as defined below). Optionally, the rate of flow of gas into the sequential gas delivery circuit is used to compute the volume of inspired gas entering the subject's alveoli in a respective breath [i].

[0045] According to one aspect of the method, the gas inspired by the subject in each respective breath [i] comprises a first inspired gas and a second inspired optionally neutral gas, wherein the first inspired gas is delivered in the first part of a respective breath [i] followed by a second inspired neutral gas for the remainder of the respective breath [i], the volume of the first inspired gas selected so that intake of the second inspired neutral gas at least fills the entirety of the anatomic dead space. $F_I X$ is computed prospectively from a mass balance equation expressed in terms which correspond to all or an application-specific subset of the terms in equation 1 and the first inspired gas has a concentration of gas X which corresponds to $F_I X$ for the respective breath [i].

[0046] A “tidal model of the lung” means any model of the movement of gases into and out of the lung that acknowledges that inspiration of gas into, and the expiration of gas from the lung, occurs in distinct phases, each inspiration-expiration cycle comprising a discrete breath, and that gases are inspired in to, and expired from, the lungs via the same conduit.

[0047] In terms of computing a mass balance equation and capturing relevant aspects of movement of gases into and out of the lung, a tidal model of lung is preferably understood to yield a value of $F_I X$ on a breath by breath basis from a mass balance equation. The mass balance equation is computed in terms of discrete respective breaths [i] including one or more discrete volumes corresponding to a subject's FRC, anatomic dead space, a volume of gas transferred between the subject's lung and pulmonary circulation in the respective breath [i] and an individual tidal volume of the respective breath [i]. Optionally, the mass balance equation is solved for $F_I X$.

[0048] Preferably for optimal accuracy in a universal set of circumstances, all these discrete volumes are accounted for in the mass balance equation. However, it is possible for the invention to be exploited sub-optimally or for individual circumstances in which the relative sizes of certain of these respective volumes (e.g. anatomic dead space, volume of gas X transferred between the pulmonary circulation and lung and even tidal volume (shallow breaths) may be relatively small (compared to other volumes) depending on the circumstances and hence failing to account for all of these volumes may affect achievement of a target end tidal partial pressure to an acceptable extent particularly where less accuracy is demanded.

[0049] In one embodiment of the invention, the mass balance equation (optionally written in terms of one or more concentration of gas X in one or more discrete volumes of gas):

[0050] a. Preferably accounts for the total amount of gas X in the lung following inhalation of the inspired gas in a respective breath [i] ($M_LX[i]$) including transfer of gas X between the lung and the pulmonary circulation;

[0051] b. Assumes distribution of $M_LX[i]$ into compartments including the subject's FRC ($M_LX[i]_{FRC}$), a fixed or spontaneously inspired tidal volume ($M_LX[i]_{VT}$) and preferably the subject's anatomic dead space volume ($M_LX[i]_{VD}$);

[0052] c. Assumes uniform distribution of the $M_LX[i]_{FRC}$ and $M_LX[i]_{VT}$ in the cumulative volume $FRC + V_T$;

[0053] d. Preferably includes a term that accounts for re-inspiration in a respective breath [i] of an amount of gas X left in the dead space volume after exhalation in a previous breath [i-1].

[0054] As detailed below, according to one embodiment, in which the invention is implemented via sequential gas delivery, the individual respective tidal volume for a breath [i] may consist of a first inspired gas having a concentration of gas X corresponding to $F_I X$ and second inspired neutral gas. The volume of the first inspired gas may be fixed, for example by controlling the rate of flow of first inspired gas into a sequential gas delivery circuit.

[0055] In one embodiment of the invention the mass balance equation comprises terms corresponding to all or an application-specific subset of the terms in equations 1 or 2 forth below as described hereafter. An "application-specific subset" means a subset tailored to either a minimum, intermediate or logistically optimal standard of accuracy having regard to the medical or diagnostic application of the invention in question or the sequence of $P_{ET}X[i]^T$ values targeted. Optional terms and mandatory inclusions in the subset may be considered application-specific as a function of the sequence of $P_{ET}X[i]^T$ values targeted in terms of the absolute size of the target value and/or the relative size of the target value going from one breath to the next as discussed below. For example, in most cases, the O_2 or CO_2 re-inspired from the anatomical dead space (V_D) is small compared to the O_2 or CO_2 in the other volumes that contribute to the end-tidal partial pressures. For example, where the volume of O_2 or CO_2 in the first inspired gas is very large, in trying to induce a large increase in the target end-tidal partial pressures, the O_2 or CO_2 transferred into the lung from the circulation may be comparatively small and neglected. Neglecting any terms of the mass balance equations will decrease computational

complexity at the possible expense of the accuracy of the induced end-tidal partial pressures of gases.

[0056] The demands of a diagnostic application may be ascertained empirically or from the literature. For example, a measure of short response times of brain blood vessels to hypercapnic stimulus can be determined to require a square wave change in the stimulus such as a change of 10 mmHg $P_{ET}CO_2$ from one breath to the next. Another example is when measuring response of BOLD signal with MRI to changes in partial pressure of CO_2 in the blood, the changes needed may be determined to be abrupt as the BOLD signal has considerable random drift over time.

[0057] For measuring heart vascular reactivity, the inventors have demonstrated that attaining target end tidal concentrations to within 1 to 3 mm of Hg of the targets, preferably to within 1 to 2 mm of Hg of the targets, using an apparatus, computer program product, or IC chip and method according to the invention enables the invention to be used for cardiac stress testing (see WO2012/1151583). Therefore, according to one aspect, the invention is directed to the use of apparatus, computer program product, IC chip and/or method according to the invention for cardiac stress testing.

[0058] The invention is also adapted for use as a controlled stimulus, for example to calibrate a BOLD signal (Mark C I et al. Improved fMRI calibration: Precisely controlled hyperoxic versus hypercapnic stimuli (2011) NeuroImage 54 1102-1111); Driver I D. et al. Calibrated BOLD using direct measurement of changes in venous oxygenation (2012) NeuroImage 63(3) 2278-87) or as an adjunct or preliminary step in diagnosing abnormal cerebrovascular reactivity. For example, determining the presence of abnormally reduced vascular reactivity using an apparatus, computer program product, IC chip and/or method according to the invention is useful for predicting susceptibility to stroke (Silvestrini, M. et al. Impaired Cerebrovascular Reactivity and Risk of Stroke in Patients With Asymptomatic Carotid Artery Stenosis JAMA (2000) 283 (16) 2179; Han J. S. et al. Impact of Extracranial Intracranial Bypass on Cerebrovascular Reactivity and Clinical Outcome in Patients With Symptomatic Moyamoya Vasculopathy, Stroke (2011) 42:3047-3054) or dementia (Balucani, C. et al. Cerebral Hemodynamics and Cognitive Performance in Bilateral Asymptomatic Carotid Stenosis Neurology (2012) Oct. 23; 79(17) 1788-95) and diagnosing or assessing cerebrovascular disease (Mutch W A C et al. Approaches to Brain Stress Testing: BOLD Magnetic Resonance Imaging with Computer-Controlled Delivery of Carbon Dioxide (2012) PLoS ONE 7(11) e47443).

[0059] The invention is similarly adapted for diagnosing or assessing idiopathic intracranial hypertension (IIH) or idiopathic normal pressure hydrocephalus (Chang, Chia-Cheng et al. A prospective study of cerebral blood flow and cerebrovascular reactivity to acetazolamide in patients with idiopathic normal-pressure hydrocephalus (2009) J Neurosurg 111:610-617), traumatic brain injury (Dicheskul M L and Kulikov V P. Arterial and Venous Brain Reactivity in the Acute Period of Cerebral Concussion 2011 Neuroscience and Behavioural Physiology 41(1) 64), liver fibrosis or liver disease in which liver fibrosis is a feature (Jin, N. et al. Carbogen Gas-Challenge BOLD MR Imaging in a Rat Model of Diethylnitrosamine-induced Liver Fibrosis January 2010 Radiology 254(1)129-137) and conditions manifesting abnormal kidney vascular reactivity, for example

renal denervation in transplant subjects (Sharkey et. al., Acute effects of hypoxaemia, hyperoxaemia and hypercapnia on renal blood flow in normal and renal transplant subjects, Eur Respir J 1998; 12: 653-657.

[0060] Optionally, one or more inputs for computation of $PetX[i]^T$ are “tuned” as defined below to adjust, as necessary or desirable, estimated or measured values for FRC and/or total metabolic production/consumption of gas X so as to reduce the discrepancy between targeted and measured end tidal partial pressures of gas X i.e. an actual value, optionally measured at the mouth. Tuning can be done when a measured baseline steady state value of $PetX[i]$ is defined for a series of test breaths.

[0061] According to another aspect, the present invention is directed to an apparatus for controlling an amount of at least one gas X in a subject’s lung to attain a targeted end tidal partial pressure of the at least one gas X, comprising:

[0062] (1) a gas delivery device;

[0063] (2) a control system for controlling the gas delivery device including means for:

[0064] a. Obtaining input of a concentration of gas X in the mixed venous blood entering the subject’s pulmonary circulation for gas exchange in one or more respective breaths [i] ($C_{MV}X[i]$);

[0065] b. Obtaining input of a logistically attainable end tidal partial pressure of gas X ($PetX[i]^T$) for a respective breath [i];

[0066] c. Obtaining input of a prospective computation of an amount of gas X required to be inspired by the subject in an inspired gasset for delivery to the subject by the gas delivery device to target the $PetX[i]^T$ for a respective breath [i] using inputs required to compute a mass balance equation including $C_{MV}X[i]$, wherein one or more values required to control the amount of gas X in a volume of gas delivered to the subject is output from the mass balance equation; and

[0067] d. Controlling the amount of gas X in a volume of gas delivered to the subject in a respective breath [i] to target the respective $PetX[i]^T$ based on the prospective computation.

[0068] In one embodiment of the method, a concentration of gas X (F_X) is computed to target or attain $PetX[i]^T$ in a respective breath [i].

[0069] Optionally, the mass balance equation is solved for F_X .

[0070] It will be appreciated the control system may implement one or more embodiments of the method described herein.

[0071] In one embodiment of the apparatus the gas delivery device is a sequential gas delivery device, for example a gas blender operatively connected to a sequential gas delivery circuit.

[0072] In one embodiment of the apparatus, the control system is implemented by a computer.

[0073] In one embodiment of the apparatus, the computer provides output signals to one or more rapid (rapid-response) flow controllers.

[0074] In one embodiment of the apparatus, the apparatus is connected to a sequential gas delivery circuit.

[0075] In one embodiment of the apparatus, the computer receives input from a gas analyzer and an input device adapted for providing input of one or more logistically attainable target end tidal partial pressure of gas X ($PetX[i]^T$) for a series of respective breaths [i].

[0076] In one embodiment of the apparatus, the control system, in each respective breath [i], controls the delivery of at least a first inspired gas and wherein delivery of the first inspired gas is coordinated with delivery a second inspired neutral gas, wherein a selected volume of the first inspired gas is delivered in the first part of a respective breath [i] followed by the second inspired neutral gas for the remainder of the respective breath [i], wherein volume of the first inspired gas is fixed or selected for one or more sequential breaths by way of user input so that intake of the second inspired neutral gas at least fill the entirety of the anatomic dead space.

[0077] In one embodiment of the apparatus, the apparatus is connected to a sequential gas delivery circuit.

[0078] In one embodiment of the apparatus, the gas delivery device is a gas blender.

[0079] In one embodiment of the apparatus, the control system implements program code stored in a computer readable memory or comprises a signal processor embodied in an IC chip, for example, one or more programmable IC chips.

[0080] According to another aspect, the present invention is directed to a computer program product for use in conjunction with a gas delivery device to control an amount of at least one gas X in a subject’s lung to attain a target end tidal partial pressure of a gas X in the subject’s lung, comprising program code for:

[0081] a. Obtaining input of a concentration of gas X in the mixed venous blood entering the subject’s pulmonary circulation for gas exchange in one or more respective breaths [i] ($CM_{VX}[i]$);

[0082] b. Obtaining input of a logistically attainable end tidal partial pressure of gas X ($PetX[i]^T$) for a respective breath [i];

[0083] c. Obtaining input of a prospective computation of an amount of gas X required to be inspired by the subject in an inspired gas to target the $PetX[i]^T$ for a respective breath [i] using inputs required to compute a mass balance equation including $C_{MV}X[i]$, wherein one or more values required to control the amount of gas X in a volume of gas delivered to the subject is output from the mass balance equation; and

[0084] d. Controlling the amount in a volume of gas delivered to the subject in a respective breath [i] to target the respective $PetX[i]^T$ based on the prospective computation.

[0085] In one embodiment of the method, a concentration of gas X (F_X) is computed to target or attain $PetX[i]^T$ in a respective breath [i].

[0086] Optionally, the mass balance equation is solved for F_X .

[0087] It will be appreciated the computer program product may be used in conjunction with a gas delivery device, to at least partially implement a control system for carrying out one or more embodiments of the method described herein.

[0088] The program code may be stored in a computer readable memory or embodied in one or more programmable IC chips.

[0089] The present invention is also directed to the use of an aforementioned method, apparatus or computer program product to:

[0090] a) Provide a controlled vasoactive stimulus for measurement of vascular reactivity;

[0091] b) Provide a controlled vasoactive stimulus for measurement of cerebrovascular reactivity;

[0092] c) Provide a controlled vasoactive stimulus for measurement of liver, kidney, heart or eye vascular reactivity; or

[0093] d) Simultaneously change the subject's end tidal partial pressures of oxygen and carbon dioxide to selected values, for example to potentiate a diagnosis or treat cancer.

[0094] According to another aspect, the present invention is directed to a method of controlling an amount of at least one gas X in a subject's lung to attain a targeted end tidal partial pressure of the at least one gas X, comprising:

[0095] a. Obtaining input of a concentration of gas X in the mixed venous blood entering the subject's pulmonary circulation for gas exchange in one or more respective breaths [i] ($C_{MV}X[i]$);

[0096] b. Obtaining input of a prospective computation of an amount of gas X required to be inspired by the subject in an inspired gas to target the $PetX[i]^T$ for a respective breath [i] using inputs required to compute a mass balance equation including $C_{MV}X[i]$, wherein one or more values required to control the amount of gas X in a volume of gas delivered to the subject is output from the mass balance equation, the mass balance equation comprising terms corresponding to all or an application-specific subset of the terms set forth in:

$$F_i X[i] = \frac{(P_{ET}X[i]^T - P_{ET}X[i-1]^T) \cdot (FRC + V_T) + P_{ET}X[i-1]^T \cdot (FG_1 \cdot T_B) - PB \cdot Q \cdot (1-s) \cdot T_B \cdot (C_{MV}X[i] - C_pX[i])}{FG_1 \cdot T_B \cdot PB} \quad \text{eq. 1}$$

$$F_i X[i] = \frac{P_{ET}X[i]^T \cdot (FRC + V_T) - P_{ET}X[i-1]^T \cdot (FRC + V_D) - PB \cdot Q \cdot (1-s) \cdot T_B \cdot (C_{MV}X[i] - C_pX[i])}{(V_T - V_D) \cdot PB} \quad \text{eq. 2}$$

[0097] c. Controlling the amount of gas X in a volume of gas delivered to the subject in a respective breath [i] to target the respective $PetX[i]^T$ based on the prospective computation.

[0098] The terms referred to the equations are defined herein.

[0099] In one embodiment of the method, a concentration of gas X ($F_i X$) is computed to target or attain $PetX[i]^T$ in a respective breath [i].

[0100] Optionally, the mass balance equation is solved for $F_i X$.

[0101] According to one embodiment, the gas inspired by the subject in each respective breath [i] comprises a first inspired gas and a second inspired neutral gas (as defined hereafter), wherein a selected volume of the first inspired gas is delivered in the first part of a respective breath [i] followed by a second inspired neutral gas for the remainder of the respective breath [i], the volume of the first inspired gas selected so that intake of the second inspired neutral gas at least fills the entirety of the anatomic dead space.

[0102] The verb "target" used with reference to achieving a logistically attainable $PetX[i]^T$ value for a respective breath [i] means "attain" with the relative precision pragmatically demanded by the particular therapeutic or diagnostic application in question or the sequence of targets sought to be attained in both absolute and relative (between

contiguous breaths) terms. (as used herein the interchangeable phrase 'attain a target' or similar expressions similarly imply that the same relative desirable precision is achieved). For example, as discussed below, by "tuning" values for certain inputs into equation 1 or 2 (particularly functional residual capacity and total metabolic consumption or production of gas X) a logistically attainable end tidal partial pressure of gas X could be attained with relative precision in one breath. The logistically attainable $PetX[i]^T$ value could theoretically be attained with a clinically acceptable reduced precision by not tuning those values or foregoing other optimizations, as described herein, for example, by tuning total metabolic production or consumption of gas X without tuning FRC, which would be expected to delay getting to the target value more precisely by several breaths.

[0103] For purposes herein, it is understood that limitations of a physiological or other nature may impinge on attaining a $PetX[i]^T$. Given a logistically attainable target for which parameters known to impinge on accuracy, that can be optimized (described herein e.g. tuning FRC and total metabolic consumption/production of gas X) are optimized, we have found that a $PetX[i]^T$ can be considered to be "attained" as a function of the difference between the targeted value and a steady state value measured for an individual. For example, assuming a measurement error of +/-2 mm. of Hg, in the case of CO_2 , for a $PetX[i]^T$ between 30 and 50 mmHg, a measured $PetCO_2$ value that is within 1 to 3 mm of Hg of $PetX[i]^T$ can be considered to be "attained". Tuning to an extent that achieves a measured value within this range will serve as an indicator as to whether tuning has been successfully completed or should be continued. However in principle, tuning may be iterated until the difference between the measured and targeted $PetX$ is minimized. However, for a $PetCO_2[i]^T$ between 51 and 65 mmHg, a measured $PetX$ value that is within (i.e. +/-) 1 to 5 mm. of Hg of $PetCO_2[i]^T$ can be considered to be "attained" and the success of a given tuning sequence can be judged accordingly.

[0104] In the case of oxygen, a measured $PetO_2$ value that is within 5-10% of $PetO_2[i]^T$ can be considered to be one which has "attained" $PetO_2[i]^T$. For example, if the target $PetO_2$ value is between 75 mm of Hg and 150 mm of Hg a range of measured values that proportionately is within (i.e. +/-) 4 mm and 8 mm of Hg (5 and 10% of 75 respectively) to +/-8 mm to 15 mm of Hg (5-10% of 150) can be considered to be attained (similarly for a target of 100 mm of Hg, +/-5-10 mm of Hg; and for a $PetO_2[i]^T$ of 200 mm Hg, +/-10-20 mm of Hg).

[0105] However, as described above, depending on the demands of the application and the circumstances, a $PetX[i]^T$ can be considered to be "targeted" with a deliberately reduced precision (as opposed to "attained" as a goal) if parameters known to impinge on accuracy, that can be optimized (described herein e.g. tuning FRC and total metabolic consumption/production of gas X) are deliberately not optimized. The invention as defined herein (not to the exclusion of variations apparent to those skilled in the art) is nevertheless exploited inasmuch as various aspects of the invention described herein provide for a prospective targeting system, a system that can be judiciously optimized (or not) to accommodate a variety of circumstances and sub-optimal uses thereof. A $PetX[i]^T$ can be considered to have been "targeted" by exploiting the invention as defined, in one embodiment, after executing a sequence of tuning

breaths, wherein the tuning sequence optionally establishes that the optimizations defined herein make the target “attainable”.

[0106] According to another aspect, the present invention is also directed to a preparatory method for using a gas delivery device to control an amount of at least one gas X in a subject’s lung to attain a targeted end tidal partial pressure of the at least one gas X, comprising the step of executing a sequence of “tuning” breaths as described hereafter.

[0107] Optionally, one or more inputs for computation of $P_{etX}[i]^T$ are “tuned” as defined below to adjust, as necessary or desirable, estimated or measured values for FRC and/or total metabolic production/consumption of gas X so as to reduce the discrepancy between targeted and measured end tidal partial pressure of gas X i.e. an actual value, optionally measured at the mouth. Tuning is preferably done when a measured baseline steady state value of $P_{etX}[i]$ is ascertained for a series of ensuing test breaths.

[0108] According to one embodiment of the invention, an estimated or measured value for the subject’s functional residual capacity (FRC) is tuned.

[0109] Optionally, FRC is tuned in a series of tuning breaths by:

[0110] a. changing the targeted end tidal partial pressure of gas X between a tuning breath $[i+x]$ and a previous tuning breath $[i+x-1]$;

[0111] b. comparing the magnitude of the difference between the targeted end tidal partial pressure of gas X for said tuning breaths $[i+x]$ and $[i+x-1]$ with the magnitude of the difference between the measured end tidal partial pressure of gas X for the same tuning breaths to quantify any discrepancy in relative magnitude; and

[0112] c. adjusting the value of FRC in proportion to the discrepancy to reduce the discrepancy in any subsequent prospective computation of $F_T X$.

[0113] Optionally, FRC is tuned in a series of tuning breaths in which a sequence of end tidal partial pressures of gas X is targeted at least once by:

(a) obtaining input of a measured baseline steady state value for $P_{etX}[i]$ for computing $F_T X$ at start of a sequence;

(b) selecting a target end tidal partial pressure of gas X ($P_{etX}[i]^T$) for at least one tuning breath $[i+x]$ wherein $P_{etX}[i+x]^T$ differs from $P_{etX}[i+x-1]^T$; and

(c) comparing the magnitude of the difference between the targeted end tidal partial pressure of gas X for said tuning breaths $[i+x]$ and $[i+x-1]$ with the magnitude of the difference between the measured end tidal partial pressure of gas X for the same tuning breaths to quantify any discrepancy in relative magnitude;

(d) adjusting the value of FRC in proportion to any discrepancy in magnitude to reduce the discrepancy in a subsequent prospective computation of $F_T X$ including in any subsequent corresponding tuning breaths $[i+x-1]$ and $[i+x]$ forming part of an iteration of the sequence.

[0114] According to one embodiment of the invention, an estimated or measured value of the subject’s total metabolic production or consumption of gas X is tuned.

[0115] Optionally, the total metabolic production or consumption of gas X is tuned in a series of tuning breaths by comparing a targeted end tidal partial pressure of gas X ($P_{etX}[i+x]^T$) for the at least one tuning breath $[i+x]$ with a corresponding measured end tidal partial pressure of gas X for the corresponding breath $[i+x]$ to quantify any discrepancy

and adjusting the value of the total metabolic production or consumption of gas X in proportion to any discrepancy to reduce the discrepancy in any subsequent prospective computation of $F_T X$.

[0116] Optionally, the total metabolic consumption or production of gas X is tuned in a series of tuning breaths in which a sequence of end tidal partial pressures of gas X is targeted at least once by:

(a) obtaining input of a measured baseline steady state value for $P_{etX}[i]$ for computing $F_T X$ at start of a sequence;

(b) targeting a selected target end tidal partial pressure of gas X ($P_{etX}[i]^T$) for each of a series of tuning breaths $[i+1 \dots i+n]$, wherein $P_{etX}[i]^T$ differs from the baseline steady state value for $P_{etX}[i]$;

(c) comparing the targeted end tidal partial pressure of gas X ($P_{etX}[i+x]^T$) for at least one tuning breath $[i+x]$ in which the targeted end tidal gas concentration of gas X has been achieved without drift in a plurality of prior breaths $[1+x-1, 1+x-2 \dots]$ with a corresponding measured end tidal partial pressure of gas X for a corresponding breath $[i+x]$ to quantify any discrepancy and adjusting the value of the total metabolic consumption or production of gas X in proportion to the discrepancy to reduce the discrepancy in a subsequent prospective computation of $F_T X$ including in any subsequent corresponding tuning breath $[i+x]$ forming part of an iteration of the sequence.

[0117] All key inputs for computing $F_T X$ are itemized below.

[0118] We have found that a prospective model which predicts an $F_T X$ that is required to target a logistically attainable end tidal partial pressure of a gas X is simplified and enhanced by using a sequential gas delivery system (alternatively called a sequential gas delivery device, or sequential rebreathing).

[0119] According to another embodiment, the apparatus according to the invention is a “sequential gas delivery device” as defined hereafter. The sequential gas delivery device optionally comprises a partial rebreathing circuit or a sequential gas delivery circuit as defined hereafter.

[0120] The rate of gas exchange between the subject’s mixed venous blood and alveoli for a respective breath $[i]$ may be controlled by providing a partial re-breathing circuit through which the subject inspires a first gas in which the concentration of gas X is $F_T X$ and a second gas having a partial pressure of gas X which is substantially equivalent to the partial pressure of gas X in the subject’s end tidal expired gas prior to gas exchange in the current respective breath $[i]$ (the subject’s last expired gas which is made available for re-breathing) or a gas formulated in situ to match a concentration of gas X which would have been exhaled in a prior breath. Practically, this may be accomplished by setting the rate of gas flow into the partial rebreathing circuit for a respective breath $[i]$ to be less than the patient’s minute ventilation or minute ventilation minus anatomic dead space ventilation (i.e. such that the last inspired second gas at least fills the anatomical dead space if not also part of the alveolar space) and using this rate or the volume of inspired gas it represents in a current breath to compute $F_T X$ for a respective breath $[i]$.

[0121] With reference to parameters used to compute terms in equation 1 or 2, it is understood that phrases like “obtaining input” and similar expressions are intended to be understood broadly to encompass, without limitation, input obtained by or provided by an operator of a gas delivery

device through any form of suitable hardware input device or via programming or any form of communication or recordation that is translatable into an electronic signal capable of controlling the gas delivery device.

[0122] According to another aspect, the invention is also directed to a method of controlling an amount of at least one gas X in a subject's lung to attain, preliminary to or during the course of a diagnostic or therapeutic procedure, at least one target end tidal partial pressure of a gas X.

[0123] A $PetX[i]$ attained for any immediately previous breath $[i-1]$ is:

[0124] a. alterable, prospectively, to any other logistically attainable value, in one breath, using a method or apparatus according to the invention;

[0125] b. maintainable, prospectively, without drift, in a respective breath $[i]$ or in breath $[i]$ and in one or more subsequent breaths $[i+1]$. . . $[i+n]$ using a method or apparatus according to the invention.

[0126] According to one embodiment of the invention, a input of a concentration of gas X in the mixed venous blood entering the subject's lung for gas exchange in the respective breath $[i]$ ($C_{MV}X[i]$) can be obtained (e.g. predicted) by a compartmental modelling of gas dynamics. "Compartmental modeling of gas dynamics" means a method in which body tissues are modeled as system of one or more compartments characterized in terms of parameters from which the mixed-venous return of gas X can be predicted. These parameters include the total number of compartments, the fraction of the total cardiac output received by the respective compartment, the respective compartment's storage capacity for gas X and the fraction of the overall production/consumption of gas X that can be assigned to the compartment.

[0127] The total number of compartments (ncomp) in the model must be known or selected, and then each compartment (k) is assigned a fraction of the total cardiac output (qk), a storage capacity for gas X (dXk), and a fraction of the overall production/consumption rate of gas X (vXk). In general, the storage capacity for any gas X in a compartment is known for an average subject of a particular weight, and then scaled proportional to the actual weight of the subject under test.

[0128] Modeling/predicting the mixed-venous return can be done for any gas X using the following information:

1. A formula for conversion of end-tidal partial pressures to blood content of gas X (i.e. determining the content of the gas X in the pulmonary end-capillary blood based on data with respect to partial pressures).
2. the fraction of the overall production/consumption of the gas X which occurs in the compartment;
3. the storage capacity of the compartment for gas X;
4. blood flow to/from the compartment.

[0129] Some examples of gas X include isoflurane, carbon dioxide and oxygen.

[0130] Compartmental modeling of gas dynamics may be simplified using a single compartment model.

[0131] Means for controlling gas delivery typically include suitable gas flow controllers for controlling the rate of flow of one or more component gases. The gas delivery may be controlled by a computer for example an integrated computer chip or an external computer running specialized computer readable instructions via which inputs, computations and other determinations of parameter and controls are made/handled. The computer readable instructions may be

embodied in non-transitory computer readable medium which may be distributed as a computer program product.

[0132] It will be appreciated that logistically attainable target values for end tidal partial pressures of gas X may be set for respective breaths within a series breaths which are taken preliminary to or as part of a diagnostic or therapeutic procedure. Typically these values are defined in advance for the series or for at least part of the series of breaths. As described below, these individually logistically attainable values may be used to attain values in multiple breaths that are not logistically attainable in one breath.

[0133] The term "tuning" and related terms (e.g. tune, tuned etc.) means that a value for an estimated or measured parameter that is required to compute $F_T X$ is adjusted, as necessary or desirable, to enable more precise computation of the $F_T X$ required to achieve a $PetX[i]^T$, preferably based on observed differences between the target $PetX[i]^T$ set for one or more respective breaths and actual $PetX[i]$ value(s) obtained for the respective breath(s), if any, such that post-adjustment observed value(s) more closely match the respective target value(s). The tuned parameter(s) can be understood to fall into two categories: lung and non-lung related parameters. Preferably, the lung related parameter is FRC. A step change in the end tidal partial pressure of gas X is required to tune this parameter. Non-lung related parameters are preferably tissue related parameters, preferably those required for computing a compartmental model of gas dynamics, preferably parameters governing total metabolic production or consumption of gas X in the body or the overall cardiac output, optionally parameters affecting assessment of the contribution of a respective compartment to the mixed venous content of gas X, preferably as a function of the production or consumption of gas X in the respective compartment, the assigned storage capacity for gas X in the respective compartment and the contribution of blood flow from the respective compartment to the total cardiac output, for example, by observing that a repeatedly targeted value does not drift when attained. Drift can be defined in the negative or considered to have been corrected for, for example, if an adjusted value for a tissue related parameter results in a variation of no greater than 1 to 2 mm of Hg (ideally approximately 1 mm of Hg or less) between observed and targeted end tidal values of gas X for a series of 5 consecutive breaths (i.e. where the end tidal partial pressure of gas X is sought to be maintained for a series of breaths e.g. 30 breaths and observed drift is corrected).

[0134] Tuning FRC is important for transitioning accurately between end-tidal values. Tuning non-lung related parameters e.g. VCO_2 is important so that the steady state error between end-tidal values is small. The tuning requirements depend on the goals of the targeting sequence. For example, in the case of inducing a step increase in the end-tidal partial pressure of CO_2 from 40 mmHg to 50 mmHg, if attaining 50 mmHg in the first breath is important, FRC is preferably tuned. If achieving 50 mmHg in the first breath is not vital, but achieving this target in 20 breaths is all that may matter, a non-lung related parameter such as VCO_2 should be tuned. If the goal of the end tidal targeting sequence is to achieve 50 mmHg in one breath, and then maintain 50 mmHg for the ensuing 20 breaths, both FRC and a non-lung related parameter should be tuned. If you don't care if you get to 50 mmHg in the first breath, and then drift to 55 after 20 breaths, don't tune either.

[0135] The following are examples of end tidal values that would be achieved for each combination. Assume transition is made on the second breath (bold):

Tuned FRC (good transition), untuned VCO₂ (bad steady state error)—40, 50, 51, 52, 53, 54, 55, 55, 55, 55, 55, 55

Untuned FRC (bad transition), tuned VCO₂ (no steady state error)—40, 59, 56, 53, 52, 51, 50, 50, 50, 50, 50

Tuned FRC (good transition), tuned VCO₂ (no steady state error)—40, 50, 50, 50, 50, 50, 50, 50, 50,

Untuned FRC (bad transition), untuned VCO₂ (bad steady state error)—40, 62, 60, 58, 57, 56, 55, 55, 55, 55.

[0136] For example, to achieve a progressively increasing end tidal partial pressure of gas X where the actual or absolute values are not of concern, only that the values keep increasing in each breath, it would not be necessary to tune FRC or VCO₂. However, to transition from 40 to 50 mmHg (for example, where gas X is CO₂), though not necessarily in one breath, it would be preferable to tune a non-lung related parameter e.g. VCO₂ but not FRC. If it were important to transition from 40 mmHg to 50 mmHg in one breath, but not so important if the end tidal values drifted away from 50 mmHg after the first breath, it would be important to tune FRC but not VCO₂ etc. Nevertheless, a target would be set for each respective breath [i] and that target would be effectively attained with a degree of accuracy and immediacy necessary for the application in question. Accordingly, a tidal based model for targeting end tidal partial pressure of a gas X provides a tunable flexible system for attaining those targets in line with a wide variety of objectives of the user.

[0137] It is to be understood that this tuning can be applied independently to each of the gases that are being targeted, as each gas can be targeted independently of the other gases.

[0138] An attainable target may be maintained in one or more subsequent breaths by setting the target end tidal value for the respective breath to be the same as PetX[i-1]. A target that is not attainable in one breath may be obtained in a series of breaths [i] . . . [i+n].

[0139] As suggested above and discussed below, it is possible that a particular end tidal partial pressure is not logistically attainable in one breath. If logistically attainable at all, such a target may be logistically attained only after multiple breaths. In contrast to methods requiring negative feedback, in one aspect of the method of the present invention this number of breaths may be pre-defined prospectively. This number of breaths may also be minimized so that the ultimate end tidal target is attained as rapidly as logistically feasible, for example by simple computational trial and error with respect to an incremented series of target. As described below, logistic constraints could be seen as limitations to inhaling the amount of the gas X that needs to be inhaled to reach a target concentration on the next breath; this could be because of limitations of available concentration X, or volume of inspired gas or both. Mandatory constraints are at least those inherent in any method of controlling the end tidal partial pressure of a gas X by way of inhalation of concentrations of gas X in that F_TX cannot be less 0% and greater than 100% for any given breath. Constraints may also be selected as a matter of operational necessity or efficiency so called “operational constraints” which may be self-imposed but not mandatory in all cases. For example, practically speaking, it may be inadvisable for safety reasons to administer a gas X (especially where gas X is not oxygen) in the highest feasible concentrations due to

patient safety risks accompanying failure of the system. Accordingly, for safety reasons it may be advisable for a component gas comprising gas X to have at least 10% oxygen thereby defining an optional logistical limit of the method. Therefore what is logistically achievable is understood to be operationally limited by the composition of all the gas sources to which the apparatus is connected at any point in time. Furthermore, as described below, sequential gas delivery is typically effected by delivering a gas of a first composition followed by a neutral gas. The rate of flow and hence volume of the first gas generally controlled to within certain parameters so that the second gas at least fills the anatomic dead space. This is operationally mandatory in the sense that not all values for this parameter are workable, especially if a medically relevant target end tidal partial pressure of gas X is sought to be achieved in one breath as opposed to incrementally over several breaths. What is logistically attainable will be dictated by the extant rate of flow, if unvaried, or if varied, by the range of logistically practicable rates of flow. Hence, what is logistically attainable may be tied to independently controlled parameters which may or may not be varied. Hence, some of these operational parameters may be mandatory in a particular context or in a universal sense (running the system so that it always works without reset e.g. recalculation of prospectively calculated F_TX values for a dynamic set of breaths of interest if the tidal volume falls outside established controls.

[0140] According to one embodiment of the method, the model of gas dynamics that is used to predict C_{MV}X[i] in the mixed venous blood entering the subject's lung for gas exchange in the respective breath [i] estimates a value of C_{MV}X[i] by: (a) dividing tissues to which the subject's arterial blood circulates into one or more compartments (k); and (b) determining the contribution of a respective compartment to the mixed venous content of gas X as a function of the production or consumption of gas X in the respective compartment, the assigned storage capacity for gas X in the respective compartment and the contribution of blood flow from the respective compartment to the total cardiac output or pulmonary blood flow. For example, where gas X is carbon dioxide the content of carbon dioxide in the mixed venous blood leaving a compartment C_VCO_{2,k}[i] is determined by assigning to a compartment a fraction of the overall metabolic carbon dioxide production (vco_{2,k}), a fraction of the total cardiac output (q_k) and a storage capacity for carbon dioxide (dCO_{2,k}).

[0141] In contrast to a negative feedback system, the afore-described system is a prospective end-tidal targeting system. Prior to execution of an end-tidal targeting sequence, the tissue model is used to predict the time course of the mixed-venous blood gases that will result from ideal execution of the sequence.

[0142] The time course of predicted mixed-venous gases is used to compute the series of inspired gas mixtures required to realize the target end-tidal partial pressures of gases. In this way, assuming that the end-tidal partial pressures of gases adhere to the targets allows prediction of the mixed-venous gases, and prediction of the mixed-venous gases allows a priori calculation of the inspired gas mixtures required to accurately implement the end-tidal targets. There is no requirement to modify the series of the inspired gas mixtures calculated before execution of the sequence based on deviations of the measured end-tidal partial pressures of gases from the targets during execution of the sequence.

[0143] Instead, the system is tuned to obtain tuned values for certain parameters before execution of the sequence so that the end-tidal partial pressures of gases induced during sequence execution closely adhere to the target functions without the need for any feedback control.

[0144] Optionally, the program code includes code for directing a suitable gas delivery device such as a rapid flow controller to deliver a gas X containing gas having an F_{IX} output from a mass balance equation. The term “gas delivery means” by contrast to gas delivery device refers to a discrete component of a gas delivery device that is used to control the volume of gas delivered at a particular increment in time such as a rapid flow controller.

[0145] It will be appreciated that each of the key method steps for carrying out the invention can be functionally apportioned to different physical components or different computer programs and combinations of both. Furthermore a device according to the invention will optionally comprise one or more physical components in the form of a gas analyzer, a pressure transducer, a display, a computer, a gas delivery device such as a rapid flow controller, a gas channeling means (gas conduits/tubes), standard electronic components making up a PCB, input devices for setting parameters etc. The various means for carrying out these steps include without limitation one in the same physical means, or different physical means on different devices, the same device or the same device component. Depending on the number of added gases these components may multiplied or where possible shared.

[0146] In another aspect, the present invention is also directed to a device comprising an integrated circuit chip configured for carrying out the method, or a printed circuit board (comprising discrete or integrated electronic components). The device optionally includes at least one gas delivery means such as a rapid flow controller. The device optionally includes an input device for inputting various parameters described herein. The parameters can be input via a variety of means including, but not limited to, a keyboard, mouse, dial, knob, touch screen, button, or set of buttons.

[0147] It is understood that any input, computation, output, etc. described herein can be accomplished by a variety of signal processing devices (alternatively termed “signal processors”) including, but not limited to, a programmable processor, a programmable microcontroller, a dedicated integrated circuit, a programmable integrated circuit, discrete analog or digital circuitry, mechanical components, optical components, or electrical components. For example, the signal processing steps needed for executing the inputs, computations and outputs can physically embodied in a field programmable gate array or an application specific integrated circuit.

[0148] The term “blending” may be used to describe the act of organizing delivery of one gas in conjunction with at least one other and hence the term blending optionally encompasses physical blending and coordinated release of individual gas components.

[0149] The term “computer” is used broadly to refer to any device (constituted by one or any suitable combination of components) which may be employed in conjunction with discrete electronic components to perform the functions contemplated herein, including computing and obtaining input signals and providing output signals, and optionally storing data for computation, for example inputs/outputs to

and from electronic components and application specific device components as contemplated herein. As contemplated herein a signal processor or processing device in the form of a computer may use machine readable instructions or dedicated circuits to perform the functions contemplated herein including without limitation by way of digital and/or analog signal processing capabilities, for example a CPU, for example a dedicated microprocessor embodied in an IC chip which may be integrated with other components, for example in the form of a microcontroller. Key inputs may include input signals from—a pressure transducer, a gas analyzer, any type of input device for inputting a target end tidal partial pressure of gas X (for example, a knob, dial, keyboard, keypad, mouse, touch screen etc.), input from a computer readable memory etc. Key outputs include output of the flow and/or composition of gas required to a flow controller.

[0150] For example of a compartmental model for mixed venous blood carbon dioxide dynamics may assign body tissues to k compartments e.g. 5 compartments and assign the contribution of a respective compartment to the mixed venous content of carbon dioxide as a function of the production of carbon dioxide in the respective compartment, the assigned storage capacity for carbon dioxide in the respective compartment and the contribution of blood flow from the respective compartment to the total cardiac output.

[0151] In one aspect, the present invention is directed to a non-transitory computer readable memory device having recorded thereon computer executable instructions for carrying out one or more embodiments of the above-identified method. The invention is not limited by a particular physical memory format on which such instructions are recorded for access by a computer. Non-volatile memory exists in a number of physical forms including non-erasable and erasable types.

[0152] Hard drives, DVDs/CDs and various types of flash memory may be mentioned. The invention, in one broad aspect, is directed to a non-transitory computer readable medium comprising computer executable instructions for carrying out one or more embodiments of the above-identified method. The instructions may take the form of program code for controlling operation of an electronic device, the program code including code for carrying out the various steps of a method or control of an apparatus as defined above.

[0153] A “gas delivery device” means any device that can make a gas of variable/selectable composition available for inspiration. The gas delivery apparatus may be used in conjunction with a ventilator or any other device associated with a breathing circuit from which the subject is able to inspire a gas of variable/controllable composition without substantial resistance. Preferably, the composition of the gas and/or flow rate is under computer control. For example, such a device may be adapted to deliver at least one gas (pure or pre-blended) at a suitable pre-defined rate of flow. The rate of flow may be selectable using a form of input device such a dial, lever, mouse, key board, touch pad or touch screen. Preferably the device provides for one or more pure or blended gases to be combined i.e. “a gas blender”.

[0154] A “gas blender” means a device that combines one or more stored (optionally stored under pressure or delivered by a pump) gases in a pre-defined or selectable proportion for delivery a selectable rate of flow, preferably under computer control. For example or more stored gases may be

combined with pumped room air or a combination of pure or blended (each blended gas may have at least 10% oxygen for safety) gases respectively contain one of carbon dioxide, oxygen and nitrogen as the sole or predominant component. Optionally, the selectable proportion is controlled automatically using an input device, optionally by variably controlling the flow of each stored gas (pure or pre-blended) separately, preferably using rapid flow controllers, to enable various concentrations or partial pressures of a gas X to be selected at will within a pre-defined narrow or broad range. For example, a suitable blender may employ one or more gas reservoirs, or may be a high flow blender which blows gas past the mouth i.e. in which gas that is not inspired is vented to the room.

[0155] A “partial rebreathing circuit” is any breathing circuit in which a subject’s gas requirements for a breath are made up in part by a first gas of a selectable composition and a rebreathed gas to the extent that the first gas does not fully satisfy the subject’s volume gas requirements for the breath. The first gas must be selectable in at least one of composition or amount. Preferably the amount and composition of the first gas is selectable. The rebreathed gas composition optionally consists of previously exhaled gas that has been stored or a gas formulated to have the same concentration of gas X as previously exhaled gas or a second gas has a gas X concentration that is selected to correspond (i.e. has the same concentration) as that of the targeted end tidal gas composition for a respective breath [i].

[0156] Preferably the circuit is designed or employable so that the subject receives the entirety of or a known amount of the first gas in every breath or in a consecutive series of breaths forming part of gas delivery regimen. In a general sense a re-breathed gas serves a key role in that it does not contribute significantly to the partial pressure gradient for gas flow between the lung and the pulmonary circulation when intake of the gas at least fills the entirety of the anatomic dead space. Therefore, in the case of a spontaneously breathing subject (whose tidal volume is not controlled e.g. via a ventilator) the subject’s unpredictable tidal volume does not defeat prospective computation of the controlled gas composition required to attain or target $P_{et}X$ [i] for a respective breath [i].

[0157] Optionally, the “rebreathed gas” may be constituted by or substituted by a prepared gas (in terms of its gas X content). Thus, according to one embodiment of the invention, the second gas has a gas X concentration that is selected to correspond to that of the targeted end tidal gas composition for a respective breath [i]. The volume of the first inspired gas may also be adjusted (e.g. reduced) to target $P_{et}X[i]^T$ for a respective breath [i] such that the subject receives an optimal amount of a gas having a gas X concentration that corresponds to $P_{et}X[i]^T$.

[0158] As alluded to above, it will be appreciated that the gas X content of a prepared gas can be formulated to represent a gas of a “neutral” composition. Thus the total inspired gas for a respective breath [i] will comprise a first inspired gas having a controlled volume and gas X concentration ($F_I X$) and a second gas which has a gas X content whose contribution to establishing a partial pressure gradient between the lung and pulmonary circulation is optionally minimized (e.g. the neutral gas may have the gas X concentration of the end tidal target set for the current breath). In a broader sense, the second inspired gas content of gas X can be optimized to attain a targeted end tidal concentration

(for a universal set of circumstances) and in a sub-optimal sense this concentration at least does not defeat the ability to prospectively compute an $F_I X$ for the purposes of attaining or targeting a $P_{et}X[i]$ for a respective breath [i] (i.e. not knowing the subject’s tidal volume for a respective breath [i] will not preclude such computation).

[0159] “Prospectively” or a “prospective computation” means, with reference to a determination of an amount of gas X required to be inspired by the subject in an inspired gas to attain or target a $P_{et}X[i]^T$ for a respective breath [i] (optionally computed in terms of $F_I X$), using inputs required to compute a mass balance equation (preferably including $C_{M^*}X[i]$), without necessary recourse to feedback to attain rapidly and repeatably. In contrast, to a negative feedback system, which relies on ongoing measurements of $P_{et}X[i]$ to provide feedback for continually adjusting computed $F_I X$ values to minimize the discrepancy between target and measured $P_{et}X[i]$ values, the system of the present invention is adapted to attain logistically achievable end tidal values rapidly and accurately (as defined herein) without recourse to feedback. As discussed herein, a negative feedback system suffers from an inherent trade-off between response time and stability. According to the present invention, recourse to feedback is designed to be unnecessary for the purpose of attaining logistically achievable $P_{et}X$ targets rapidly and predictably. The term “computation” and similar terms used herein, for example, in the phrase “prospective computation” and related terms (e.g. compute) contemplates the possibility that a look-up table contains the computed values derived from permutations of inputs to a mass balance equation, provided that storing the requisite permutations of inputs is possible.

[0160] Of further consideration are the delays associated with measurement of the end-tidal partial pressures of gases which are required for feedback into the system. Gas composition analysis is performed by continuously drawing gas from proximal to the subject’s airway into a gas analyzer through a sampling catheter. The gas analyzer returns a time varying signal of gas composition which is, however, delayed from the actual ventilatory phase of the subject by the travel time through the sampling catheter and the response time of the gas analyzer. Therefore, at the start of any inspiration, the end-tidal partial pressures of gases from the immediately previous breath are not yet known. Where the sampling catheters are long, such as in an MRI environment where the patient is in the MRI scanner and the gas analyzers must be placed in the control room, this delay can reach three or more breaths. As in any negative feedback system, this delay in measuring the controlled parameter will further destabilize and limit the response time of the system.

[0161] A “sequential gas delivery device” means, with respect to delivering a gas in successive respective breaths [i], a device for delivery of a controlled gas mixture in the first part of a respective breath [i] followed by a “neutral” gas in the second part of the respective breath [i]. A controlled gas mixture is any gas that has a controllable composition with respect to one or more gases of interest used to compose it. Accordingly, where the gas of interest is a gas X, the controlled gas mixture has an amount of gas X, optionally defined in terms of a concentration of gas X denoted as $F_I X$. The controlled gas mixture may be referred to, for convenience, as a first inspired gas. Gas inspired in any breath is “neutral”, inter alia, if it has the same com-

position as gas expired by the subject in a previous breath. The term “neutral” gas is used because the gas in question is one which has the same partial pressure of one or more gases of interest as the blood, in the alveoli, or in the pulmonary capillaries, and hence, upon inspiration into the alveolar space, in the second part of a respective breath, this gas does not exchange any gas with the pulmonary circulation. Unless otherwise defined explicitly or implicitly a gas of interest is generally one for which the end tidal partial pressure is sought to be controlled according to the invention.

[0162] A volume of gas that enters the alveolar space and exchanges gas with the pulmonary circulation for a breath [i] may be defined independently of a fixed tidal volume, for example by:

[0163] a. setting the rate of flow of a controlled gas mixture (also termed fresh gas flow rate) in a rebreathing circuit to be less than the patient’s minute ventilation or minute ventilation minus anatomic dead space ventilation (i.e. such that the last inspired second gas at least fills the anatomical dead space if not also part of the alveolar space);

[0164] b. obtaining input of the rate of flow or volume of the controlled gas mixture into the circuit for the respective breath (this rate can be maintained from breath to breath or varied) and computing the effective volume of alveolar gas exchange for the respective breath based on the rate of fresh gas flow for the respective breath.

[0165] According to one embodiment, the rebreathing circuit is a sequential gas delivery circuit.

[0166] According to another embodiment, volume of gas that enters the alveolar space and exchanges gas with the pulmonary circulation is determined by utilizing a fixed tidal volume set for the respective breath (e.g. using a ventilator) and subtracting a volume corresponding to the subject’s anatomic dead space volume.

[0167] The F_{IX} may be set independently of the concentration of any other component of the inspiratory gas.

[0168] Optionally, a gas X and a gas Y are components of the inspired gas and a target arterial concentration of gas X and a target arterial concentration of a gas Y are selected for a respective breath, independently of each other, and, if present, independently of the concentration of any other component Z of the inspiratory gas.

[0169] A mass balance equation that comprises terms “corresponding to” all or an application-specific subset of the terms in equations 1 or 2 above means that the same underlying parameters are accounted for.

BRIEF DESCRIPTION OF THE FIGURES

[0170] The invention will now be described with reference to the figures, in which:

[0171] FIG. 1 is a schematic overview of the movement of blood and the exchange of gases throughout the entire system.

[0172] FIG. 2 is a detailed schematic representation of the movement of blood and the exchange of gases at the tissues.

[0173] FIG. 3 is a detailed schematic representation of the movement of blood and the exchange of gases at the lungs when sequential rebreathing is not employed.

[0174] FIG. 4 is a detailed schematic representation of the movement of blood and the exchange of gases at the lungs when sequential rebreathing is employed.

[0175] FIG. 5 is a schematic diagram of one embodiment of an apparatus according to the invention that can be used to implement an embodiment of a method according to the invention.

[0176] FIG. 6 is a graphic representation of a tuning sequence and observed errors that can be used to tune model parameters.

[0177] FIG. 7 is a Table of abbreviations (Table 1) used in the specification.

[0178] FIG. 8, is a representative raw data sample excerpted from the study of 35 subjects referred to in Example 1, showing a targeting sequence wherein normocapnia (40 mm Hg targeted three times) and hypercapnia (50 mm Hg targeted twice) were sequentially targeted in 6 study subjects.

DETAILED DESCRIPTION OF A PREFERRED EMBODIMENT

[0179] The invention is described hereafter in terms of one or more optional embodiments of a gas X, namely carbon dioxide and oxygen.

Prospective Modelling

[0180] Mass balance equations of gases in the lung are conventionally derived from a continuous flow model of the pulmonary ventilation. In this model, ventilation is represented as a continuous flow through the lungs, which enters and exits the lungs through separate conduits. As a consequence, for example, the anatomical dead space would not factor into the mass balance other than to reduce the overall ventilatory flow into the alveolar space. In reality, however, ventilation in humans is not continuous, but tidal. Gas does not flow through the lungs, but enters the lungs during a distinct inspiration phase of the breath and exits during a subsequent expiration phase of the breath. In each breath cycle, gas is inspired into the lungs via the airways and expired from the lungs via the same airways through which gas was inspired. One possible implication, for example, is that the first gas inspired into the alveolar space in any breath is residual gas which remains in the anatomical dead space following the previous expiration. Continuous flow models neglect the inspiration of residual gas from the anatomical dead space, and therefore, since accounting for such a factor is generally desirable, do not accurately represent the flux of gases in the lungs.

[0181] As continuous flow models of pulmonary ventilation do not correctly represent the flux of gases in the lungs, the end-tidal partial pressures of gases induced from the inspiration of gas mixtures computed from such a model will, necessarily, deviate from the targets.

[0182] By contrast, according to one aspect of the present invention, a mass balance equation of gases in the lungs is preferably formulated in terms discrete respective breaths [i] including respective discrete volumes corresponding to one or more of the FRC, anatomic dead space, the volume of gas X transferred between the pulmonary circulation and the lung in a respective breath [i] and an individual tidal volume of a respective breath [i] is adaptable to account, for example, for inspiration of residual gas from the anatomical dead space into the alveolar space in each breath. Inasmuch as a tidal model more faithfully represents the actual flux of gases in the lungs compared with the conventional model, the induced end-tidal partial pressures of gases, to an extent

that the model is fully exploited, it will more closely adhere to the targets compared with results achieved using a continuous flow model.

[0183] Moreover, we have found that using a tidal model of pulmonary ventilation, can be synergistically employed with a sequential gas delivery system to facilitate closer adherence to targets in both ventilated and spontaneously breathing subjects without reliance on a negative feedback system.

[0184] According to the present invention, a prospective determination of pulmonary ventilation and gas exchange with the blood can efficiently exploited even in spontaneously breathing subjects where the ventilatory parameters are highly variable and difficult to measure.

[0185] Where mechanical ventilation is employed, a prospective model of pulmonary ventilation and gas exchange with the blood envisages that the subject's ventilatory parameters can be estimated or measured to a level of accuracy sufficient to employ prospective control of the end-tidal partial pressures of one of more gases.

[0186] According to one embodiment of the invention, a technique of inspiratory gas delivery, sequential rebreathing, which, when using a tidal model of the pulmonary ventilation, significantly reduces or eliminates the dependence of the calculation of the inspired gas composition to be delivered in each breath, and therefore the actual end-tidal partial pressures of gases induced, on the subject's ventilatory parameters.

[0187] In parallel to what we have observed from studies with respect to the subject's ventilatory parameters, we have found that when we run a set of standardized tuning sequences, our model of the tissues more accurately reflects the actual dynamics of the gas stored in the subject's tissues. The model parameters may be refined until the end-tidal partial pressures of gases induced by execution of the tuning sequences sufficiently adhere to the targets without the use of any feedback control.

Sequential Gas Delivery

[0188] Sequential rebreathing is a technique whereby two different gases are inspired in each breath a controlled gas mixture followed by a "neutral" gas. A controlled gas mixture is any gas that has a controllable composition. Gas inspired in any breath is neutral if it has the same composition as gas expired by the subject in a previous breath. Neutral gas is termed as such since it has substantially the same partial pressures of gases as the blood in the pulmonary capillaries, and hence, upon inspiration into the alveolar space, does not substantially exchange any gas with the pulmonary circulation. Optionally, the rebreathed gas has a composition that is selected to correspond (i.e. have the same gas X concentration as that of) the targeted end tidal gas composition for a respective breath [i]. It will be appreciated that a modified sequential gas delivery circuit in which the subject exhales via a port leading to atmosphere and draws on a second gas formulated by a second gas delivery device (e.g. a gas blender) could be used for this purpose, for example where the second gas is deposited in an open ended reservoir downstream of a sequential gas delivery valve, for example within a conduit of suitable volume as exemplified in FIG. 7 of U.S. Pat. No. 6,799,570.

[0189] Sequential rebreathing is implemented with a sequential gas delivery breathing circuit which controls the sequence and volumes of gases inspired by the subject. A

sequential gas delivery circuit may be comprised of active or passive valves and/or a computer or other electronic means to control the volumes of, and/or switch the composition or source of, the gas inspired by the subject.

[0190] The controlled gas mixture is made available to the sequential gas delivery circuit for inspiration, optionally, at a fixed rate. On each inspiration, the sequential gas delivery circuit ensures the controlled gas mixture is inspired first, for example with active or passive valves that connect the subject's airway to a source of the controlled gas mixture. The supply of the controlled gas mixture is controlled so that it is reliably depleted in each breath.

[0191] Once the supply of the controlled gas mixture is exhausted, the sequential gas delivery circuit provides the balance of the tidal volume from a supply of neutral gas exclusively, for example with active or passive valves that connect the subject airway to the subject's exhaled gas from a previous breath.

[0192] Gas expired in previous breaths, collected in a reservoir, is re-inspired in a subsequent breath. Alternatively, the composition of gas expired by the subject can be measured with a gas analyzer and a gas with equal composition delivered to the subject as neutral gas.

[0193] During inspiration of the neutral gas and expiration, the supply of the controlled gas mixture for the next inspiration accumulates at the rate it is made available to the sequential gas delivery circuit. In this way, the subject inspires only a fixed minute volume of the controlled gas mixture, determined by the rate at which the controlled gas mixture is made available to the sequential gas delivery circuit, independent of the subject's total minute ventilation, and the balance of subject's the minute ventilation is made up of neutral gas.

[0194] Examples of suitable sequential gas delivery circuits are disclosed in US Patent Application No. 20070062534. An example of a gas delivery device suitable for delivering a first inspired gas or composing a neutral gas is a volumetric type delivery device described in published PCT Application No. WO2012/139204.

[0195] The fixed availability of the controlled gas mixture may be accomplished by delivering a fixed flow rate of the controlled mixture to a physical reservoir from which the subject inspires. Upon exhaustion of the reservoir, the source of inspiratory gas is switched, by active or passive means, to neutral gas from a second gas source, for example a second reservoir, from which the balance of the tidal volume is provided.

[0196] It is assumed that in each breath the volume of the neutral gas inspired at least fills the subject's anatomical dead space. Herein, all of the controlled gas mixture reaches the alveolar space and any of the neutral gas that reaches the alveolar space does not exchange gas with the circulation as it is already in equilibrium with the pulmonary capillary blood.

[0197] Sequential gas delivery circuits may be imperfect in the sense that a subject will inspire what is substantially entirely a controlled gas mixture first. However, upon exhaustion of the supply of the controlled gas mixture, when neutral gas is inspired, an amount of controlled gas mixture is continually inspired along with the neutral gas rather than being accumulated by the sequential gas delivery circuit for the next inspiration (2). The result is that the subject inspires exclusively controlled gas mixture, followed by a blend of neutral gas and controlled gas mixture. As a result of the

imperfect switching of gases, a small amount of the controlled gas mixture is inspired at the end of inspiration and enters the anatomical dead space rather than reaching the alveolar space. In practise, the amount of controlled gas mixture lost to the anatomical dead space is small, and therefore, the amount of controlled gas mixture that reaches the alveolar space can still be assumed equal to the rate at which the controlled gas mixture is made available to the sequential gas delivery circuit for inspiration. Therefore, the method described herein can be executed, as described, with imperfect sequential gas delivery circuits.

[0198] A simple implementation of sequential rebreathing using a gas blender and passive sequential gas delivery circuit is described in references cited below (2; 3). Other implementations of sequential gas delivery are described in patents (4-8).

[0199] The contents of all references set forth below are hereby incorporated by reference.

[0200] Various implementations of sequential gas delivery have described by Joseph Fisher et al. in the scientific and patent literature.

[0201] As seen FIG. 1, which shows a high level overview of the movement of blood and the exchange of gases throughout the entire system, the majority of the total blood flow (Q) passes through the pulmonary circulation. Upon transiting the pulmonary capillaries, the partial pressures of gases in the pulmonary blood equilibrate with the partial pressure of gases in the lungs ($P_{ET}[i]$) the result is partial pressures of gases in the pulmonary end-capillary blood equal to the end-tidal partial pressures of gases in the lungs. The blood gas contents of this blood ($C_p[i]$) can then be determined from these partial pressures. The remaining fraction (s) of the total blood flow is shunted past the lungs and flows directly from the mixed-venous circulation into the arterial circulation without undergoing any gas exchange. Therefore, the gas contents of the arterial blood ($C_a[i]$) are a flow weighted average of the pulmonary end-capillary blood with gas contents equilibrated to that of the lungs, and the shunted blood with gas contents which are equal to the mixed-venous blood entering the pulmonary circulation ($C_{MV}[i]$). The arterial blood flows through the tissue capillary beds, where gases are exchanged between the blood and the tissues. There are one or more tissue capillary beds, each of which receives a fraction of the total blood flow (q) and has unique production, consumption, storage, and exchange characteristics for each gas. The gas contents in the venous blood leaving each tissue ($C_v[i]$) can be determined from these characteristics. The gas contents of the mixed-venous blood leaving the tissues ($C_{MV(T)}[i]$) are given by the flow weighted average of the gas contents in the venous blood leaving each tissue. The mixed-venous blood leaving the tissues enters the pulmonary circulation after the recirculation delay (n_R).

FIG. 2—The Tissues

[0202] As shown in FIG. 2, the total blood flow (Q) enters the tissue capillary beds from the arterial circulation, where the gas contents of the arterial blood ($C_a[i]$) are modified by gas exchange between the blood and the tissues. To obtain input of the gas contents of the mixed-venous blood, the flow of blood through the tissues is modelled as a system of one or more compartments where each compartment represents a single tissue or group of tissues. Each compartment is assumed to receive a fraction of the total blood flow (q)

and has a unique production or consumption (v) of, and storage capacity (d) for, each gas. The content of gases in the venous blood leaving each compartment ($C_v[i]$) can be determined from the arterial inflow of gases, and the assumed production or consumption, and storage of the gas in the compartment. The blood flows leaving each compartment unite to form the mixed-venous circulation. Therefore, the gas contents of the mixed-venous blood leaving the tissues ($C_{MV(T)}[i]$) are given by the flow weighted average of the gas contents in the venous blood leaving each tissue.

FIG. 3—The Lungs (No Sequential Rebreathing)

[0203] As shown in FIG. 3, gas enters the lungs in two ways diffusion from the pulmonary circulation and inspiration though the airways. The pulmonary blood flow is equal to the total blood flow (Q) less the fraction (s) of the total blood flow that is shunted past the lungs. The flux rate of gas between the lungs and the pulmonary blood flow in a breath ($VB[i]$) is, by mass balance, the product of the pulmonary blood flow and the difference between the gas contents of the mixed-venous blood ($C_{MV}[i]$) entering the pulmonary circulation and the gas contents of the pulmonary end-capillary blood ($C_p[i]$) leaving the pulmonary circulation.

[0204] The starting volume of the lungs in any breath is given by the functional residual capacity (FRC). This is the gas left over in the lungs at the end of the previous expiration, and contains partial pressures of gases equal to the target end-tidal partial pressures from the previous breath ($P_{ET[i-1]}^T$). The first part of inspiration draws gas in the anatomical dead space (V_D) from the previous breath into the alveolar space. The partial pressures of gases in this volume are equal to the target end-tidal partial pressures from the previous breath. Subsequently, a volume of a controlled gas mixture (VG_1) with controllable partial pressures of gases ($P_j[i]$) is inspired.

FIG. 4—The Lungs (Sequential Rebreathing)

[0205] As shown in FIG. 4, gas enters the lungs in two ways diffusion from the pulmonary circulation and inspiration though the airways. The pulmonary blood flow is equal to the total blood flow (Q) less the fraction (s) of the total blood flow that is shunted past the lungs. The flux rate of gas between the lungs and the pulmonary blood flow in a breath ($VB[i]$) is, by mass balance, the product of the pulmonary blood flow and the difference between the gas contents of the mixed-venous blood ($C_{MV}[i]$) entering the pulmonary circulation and the gas contents of the pulmonary end-capillary blood ($C_p[i]$) leaving the pulmonary circulation.

[0206] The starting volume of the lungs in any breath is given by the functional residual capacity (FRC). This is the gas left over in the lungs at the end of the previous expiration, and contains partial pressures of gases equal to the target end-tidal partial pressures from the previous breath ($P_{ET[i]}^T$). The first part of inspiration draws gas in the anatomical dead space (V_D) from the previous breath into the alveolar space. The partial pressures of gases in this volume are equal to the target end-tidal partial pressures from the previous breath. Subsequently, a volume of a controlled gas mixture (VG_1) with controllable partial pressures of gases ($P_j[i]$) is inspired. The average volume of the controlled gas mixture inspired into the alveoli in each breath (VG_1) is given by the flow rate of the controlled gas mixture (FG_1) to the sequential gas delivery circuit (SGDC)

delivered over one breath period (T_B). The balance of the tidal volume (V_T) is composed of a volume of neutral gas (V_{G_2}). Where a sequential gas delivery circuit is used that provides previously expired gas as neutral gas, this volume contains partial pressures of gases equal to the target end-tidal partial pressures from the previous breath.

FIG. 5—Apparatus

[0207] As shown in FIG. 5, according to one embodiment of an apparatus according to the invention, the apparatus consists of a gas blender (GB), a Hi-OX_{SR} sequential gas delivery circuit (SGDC), gas analyzers (GA), a pressure transducer (PT), a computer (CPU), an input device (ID), and a display (DX). The gas blender contains three rapid flow controllers which are capable of delivering accurate mixes of three source gases (SG_1 , SG_2 , SG_3) to the circuit. The gases are delivered to the circuit via a gas delivery tube connecting the outlet of the gas blender to the inlet of the sequential gas delivery circuit. The gas analyzers measure the partial pressures of gases at the airway throughout the breath. The analyzers sample gas for analysis proximal to the subject's airway via a sampling catheter. A small pump is used to draw gases from the subject's airway through the gas analyzers. The pressure transducer is used for measurement of the breath period (T_B) and end-tidal detection, and also connected by a sampling catheter proximal to the subject's airway. The gas analyzers and pressure transducer communicate with the computer via analog or digital electrical signals. The computer runs a software implementation of the end-tidal targeting algorithm and demands the required mixtures from the blender via analog or digital electrical signals. The operator enters the target end-tidal values and subject parameters into the computer via the input device. The display shows the measured and targeted end-tidal gases.

FIG. 6—Tuning

[0208] As illustrated in FIG. 6, with reference to examples of gas X (oxygen and carbon dioxide) parameters representing inputs for computation of F_iX can be tuned so that the measured end-tidal partial pressures of O₂ ($P_{ET}O_2[i]^M$) and the measured end-tidal partial pressures of CO₂ ($P_{ET}CO_2[i]^M$) during any sequence more closely reflect the target end-tidal partial pressures of O₂ ($P_{ET}O_2[i]^T$) and the target end-tidal partial pressures of CO₂ ($P_{ET}CO_2[i]^T$). To tune the system parameters, standardized tuning sequences are run and the measured results compared to the targets. The difference between measured end-tidal partial pressures and the target end-tidal partial pressures in the standardized tuning sequences can be used to refine the estimates of some physiological parameters.

[0209] The tuning sequence optionally sets the target end-tidal partial pressure of O₂ ($P_{ET}O_2[i]^T$) at 5 mmHg above the baseline end-tidal partial pressure of O₂ ($P_{ET}O_2^M$) throughout the sequence, and executes a 5 mmHg step-change in the end-tidal partial pressure of CO₂ ($P_{ET}CO_2[i]^T$) from 5 mmHg above the baseline end-tidal partial pressure of CO₂ ($P_{ET}CO_2^M$) to 10 mmHg above the baseline end-tidal partial pressure of CO₂ in breath 30 ($i=30$) of the sequence.

[0210] Embodiments of mass balance equations:

$$\text{No SGD: } F_iX[i] = \frac{P_{ET}X[i]^T \cdot (FRC + V_T) - P_{ET}X[i-1]^T \cdot (FRC + V_D) - PB \cdot Q \cdot (1-s) \cdot T_B \cdot (C_{MV}X[i] - C_pX[i])}{(V_T - V_D) \cdot PB}$$

$$\text{SGD: } F_iX[i] =$$

$$\frac{(P_{ET}X[i]^T - P_{ET}X[i-1]^T) \cdot (FRC + V_T) - P_{ET}X[i-1]^T \cdot (FG_1 \cdot T_B) - PB \cdot Q \cdot (1-s) \cdot T_B \cdot (C_{MV}X[i] - C_pX[i])}{FG_1 \cdot T_B \cdot PB}$$

Abbreviations and terms are repeated in FIG. 7.

Physiological Inputs

[0211] This section describes how to obtain measurements or estimates of all the physiological inputs required to execute a prospective end-tidal targeting sequence.

Subject Weight, Height, Age, and Sex:

[0212] Subject weight (W), height (H), age (A), and sex (G) can be obtained from a subject interview, an interview with a family member, from an attending physician, or from medical records. Weight and height can also be measured.

Bicarbonate:

[0213] The bicarbonate concentration ($[HCO_3]$) can be obtained from a blood gas measurement. If a blood gas measurement is not available or possible, it can be estimated as the middle of the normal range—24 mmol/L (9; 10).

Temperature:

[0214] Body temperature (T) can be obtained from a recent invasive or non-invasive measurement. If a measurement is not available or possible, it can be estimated as the middle of the normal range—37 C (11; 12).

Haemoglobin Concentration:

[0215] The haemoglobin concentration (Hb) can be obtained from a blood gas measurement. If a blood gas measurement is not available or possible, it can be estimated as the middle of the normal range for the subject's sex (G):
15 g/dL for males
13 g/dL for females (10; 13)

Shunt Fraction:

[0216] The intrapulmonary shunt fraction (s) can be measured using a variety of invasive and non-invasive techniques (14-17). If measurement is not available or possible, it can be estimated as the middle of the normal range 0.05 (18; 19).

Cardiac Output:

[0217] The cardiac output (Q) can be measured using a variety of invasive and non-invasive techniques (20-23). If measurement is not available or possible, it can be estimated from the subject's weight (W) according to the relationship:

$$Q = 10 \cdot (0.066 \cdot W + 1.4) \quad (24)$$

Breath Period:

[0218] The breath period (T_B) can be measured using a pressure transducer (PT) or flow transducer (FT) proximal to the subject's airway. Alternatively, the subject can be coached to breathe at a predetermined rate using a metronome or other prompter. If the subject is mechanically ventilated, this parameter can be determined from the ventilator settings or ventilator operator.

Recirculation Time:

[0219] The number of breaths for recirculation to occur (n_R) can be measured using a variety of invasive and non-invasive techniques (25-27). If measurement is not available or possible, it can be estimated from the breath period (T_B) and an average recirculation time (0.3 min) (28) according to the relationship:

$$n_R = 0.3 / T_B$$

Metabolic O2 Consumption:

[0220] The overall metabolic O2 consumption (VO2) can be measured using a metabolic cart. If measurement is not available or possible, it can be estimated from the subject's weight (W), height (H), age (A), and sex (G) according to the relationship:

$$VO_2 = \frac{10 \cdot W + 625 \cdot H - 5 \cdot A + 5}{6.8832} \text{ for males} \quad (29)$$

$$VO_2 = \frac{10 \cdot W + 625 \cdot H - 5 \cdot A - 161}{6.8832} \text{ for females}$$

Metabolic CO2 Production:

[0221] The overall metabolic CO2 production (VCO2) can be measured using a metabolic cart. If measurement is not available or possible, it can be estimated from the overall metabolic O2 consumption (VO2) and average respiratory exchange ratio (0.8 ml CO2/ml O2) (30) according to the relationship:

$$VCO_2 = 0.8 \cdot VO_2$$

Functional Residual Capacity:

[0222] The functional residual capacity (FRC) can be measured using a variety of respiratory maneuvers (31). If measurement is not available or possible, it can be estimated from the subject's height (H), age (A), and sex (G) according to the relationship:

$$FRC = (2.34 \cdot H + 0.01 \cdot A - 1.09) \cdot 1000 \text{ for males}$$

$$FRC = (2.24 \cdot H + 0.001 \cdot A - 1.00) \cdot 1000 \text{ for females} \quad (32)$$

Anatomical Dead Space:

[0223] The anatomical dead space (V_D) can be measured using a variety of respiratory maneuvers (33-35). If measurement is not available or possible, it can be estimated from the subject's weight (W) and sex (G) according to the relationship:

$$V_D = 1.765 \cdot W + 32.16 \text{ for males}$$

$$V_D = 1.913 \cdot W + 21.267 \text{ for females} \quad (36)$$

Rate at which the Controlled Gas Mixture is Made Available for Inspiration when Using a Sequential Gas Delivery Circuit (SGDC)

[0224] When using a sequential gas delivery circuit (SGDC), the rate at which the controlled gas mixture is made available for inspiration (FG_1) should be set so that the volume of the neutral gas inspired in each breath (VG_2) is greater than or equal to the anatomical dead space (V_D). The subject can be coached to increase their ventilation and/or the availability of the controlled gas mixture decreased until a sufficient volume of the neutral gas is observed to be inspired in each breath.

Tidal Volume:

[0225] The tidal volume (V_T) can be measured using a flow transducer (FT) proximal to the subject's airway. If measurement is not available or possible, in spontaneous breathers when using a sequential gas delivery circuit (SGDC), it can be estimated from the rate at which the controlled gas mixture (G_1) is made available for inspiration (FG_1), the breath period (T_B), and the anatomical dead space (V_D) according to the empirical relationship:

$$\text{If } FG_1 < 15000: V_T = (0.75 \cdot FG_1 + 3750) \cdot T_B + V_D$$

$$\text{else: } V_T = FG_1 \cdot T_B + V_D$$

[0226] Alternatively, the subject can be coached or trained to breathe to a defined volume using a prompter which measures the cumulative inspired volume and prompts the subject to stop inspiration when the defined volume has been inspired. If the subject is mechanically ventilated, this parameter can be determined from the ventilator settings or ventilator operator.

Target Sequence Input

[0227] The operator enters a target sequence of n breaths consisting of a target end-tidal partial pressures of O2 ($P_{ET}O_2[i]^T$) and a target end-tidal partial pressure of CO2 ($P_{ET}CO_2[i]^T$) for every breath (i) of the sequence.

Calculation of the Inspired Gas Composition to Induce Target End-Tidal Values

[0228] The partial pressure of O2 in the controlled gas mixture ($P_fO_2[i]$) and the partial pressure of CO2 in the controlled gas mixture ($P_fCO_2[i]$) required to induce the sequence of target end-tidal partial pressures of O2 ($P_{ET}O_2[i]^T$) and target end-tidal partial pressures of CO2 ($P_{ET}CO_2[i]^T$) can be calculated by executing the steps outlined in sections 6-15 for every breath of the sequence (i, i=1 . . . n).

Calculate the O2 and CO2 Partial Pressures of Pulmonary End-Capillary Blood

[0229] When sequential rebreathing is employed (2; 37; 38), we assume that the partial pressure of O2 in pulmonary end-capillary blood ($P_pO_2[i]$) is equal to the target end-tidal partial pressure of O2 ($P_{ET}O_2[i]^T$), and the partial pressure of CO2 in pulmonary end-capillary blood ($P_pCO_2[i]$) is equal to the target end-tidal partial pressure of CO2 ($P_{ET}CO_2[i]^T$) (39).

$$P_pO_2[i] = P_{ET}O_2[i]^T$$

$$P_pCO_2[i] = P_{ET}CO_2[i]^T$$

[0230] Various other formulas have been proposed to derive blood gas partial pressures from end-tidal partial pressures. For example, see (40; 41). Any of these relationships can be used in place of the above equalities.

Calculate the pH Pulmonary End-Capillary Blood

[0231] The pH of the pulmonary end-capillary blood (pH [i]) can be calculated from the Henderson Hasselbalch equation using the blood bicarbonate concentration ($[HCO_3]$), the blood CO₂ partial pressure ($P_pCO_2[i]$), and the solubility of CO₂ in blood (0.03 mmol/L/mmHg) (9).

$$pH[i] = 6.1 + \log\left(\frac{[HCO_3]}{0.03 \cdot P_pCO_2[i]}\right)$$

Calculate the O₂ Saturation of Pulmonary End-Capillary Blood

[0232] The O₂ saturation of pulmonary end-capillary blood ($S_pO_2[i]$) can be calculated from experimental equations using the body temperature (T), the blood pH (pH[i]), the blood CO₂ partial pressure ($P_pCO_2[i]$), and the blood O₂ partial pressure ($P_pO_2[i]$) (42).

$$S_pO_2[i] =$$

$$100 \cdot \frac{-8532.2289 \cdot z + 2121.401 \cdot z^2 - 67.073989 \cdot z^3 + z^4}{935960.87 - 31346.258 \cdot z + 2396.1674 \cdot z^2 - 67.104406 \cdot z^3 + z^4}$$

$$\text{where } z = P_pO_2[i] \cdot 10^{0.024(37-T) + 0.4(pH[i]-7.4) + 0.06(\log_{10} - \log P_pCO_2[i])}$$

Calculate the O₂ Content of Pulmonary End-Capillary Blood

[0233] The O₂ content of pulmonary end-capillary blood ($C_pO_2[i]$) can be calculated from the O₂ saturation of the blood ($S_pO_2[i]$), the blood haemoglobin concentration (Hb), the O₂ carrying capacity of haemoglobin (1.36 ml/g), and the solubility of O₂ in blood (0.003 ml/dL/mmHg) (43).

$$C_pO_2[i] = 1.36 \cdot Hb \cdot \frac{S_pO_2[i]}{100} + 0.003 \cdot P_pO_2[i]$$

[0234] Alternative derivations of pH, O₂ saturation, and O₂ content are reviewed in detail in (44).

Calculate the CO₂ Content of Pulmonary End-Capillary Blood

[0235] The CO₂ content of pulmonary end-capillary blood ($C_pCO_2[i]$) can be calculated from the blood haemoglobin concentration (Hb), the O₂ saturation of the blood ($S_pO_2[i]$), the blood pH (pH[i]), and the blood CO₂ partial pressure ($P_pCO_2[i]$) (45).

$$C_pCO_2[i] =$$

$$\left(1.0 - \frac{0.02924 \cdot Hb}{\left(2.244 - 0.422 \cdot \left(\frac{S_pO_2[i]}{100}\right)\right) \cdot (8.740 - pH[i])}\right) \cdot C_{pt}$$

$$\text{where: } C_{pt} = 0.0301 \cdot P_pCO_2[i] \cdot (1 + 10^{pH[i]-6.10}) \cdot 2.226$$

[0236] See also (46-48) for alternative calculations of CO₂ content.

Calculate the O₂ and CO₂ Content of Arterial Blood

[0237] The arterial blood is a mixture of the pulmonary end-capillary blood and the blood shunted past the lungs. The percentage of the cardiac output (Q) that is shunted past the lungs is given by the intrapulmonary shunt fraction (s).

[0238] The content of O₂ in the arterial blood ($C_aO_2[i]$) is a weighted average of the O₂ content of the pulmonary end-capillary blood ($C_pO_2[i]$) and the O₂ content of the blood which is shunted directly from the mixed-venous circulation ($C_{MVO_2[i]}$).

$$C_aO_2[i] = (1-s) \cdot C_pO_2[i] + s \cdot C_{MVO_2[i]}$$

[0239] The content of CO₂ in the arterial blood ($C_aCO_2[i]$) is a weighted average of the CO₂ content of the pulmonary end-capillary blood ($C_pCO_2[i]$) and the CO₂ content of the blood which is shunted directly from the mixed-venous circulation ($C_{MVCO_2[i]}$).

$$C_aCO_2[i] = (1-s) \cdot C_pCO_2[i] + s \cdot C_{MVCO_2[i]}$$

Calculate the O₂ Content of the Mixed-Venous Blood

[0240] Before returning to the venous circulation, the arterial blood passes through the tissue capillary beds where O₂ is consumed and exchanged. This system can be modelled as a compartmental system where each compartment (j) represents a single tissue or group of tissues. Each compartment is assigned a storage capacity for O₂ (dO_{2j}). Each compartment is also modelled as being responsible for a fraction (vo_{2j}) of the overall metabolic O₂ consumption (VO_2), and receiving a fraction (q_j) of the total cardiac output (Q). The content of O₂ in the venous blood leaving a compartment ($C_vO_{2j}[i]$) is equal to the content of O₂ in the compartment. Assuming an O₂ model with n_{O_2} compartments, the O₂ content of the venous blood leaving each compartment can be calculated from the O₂ content in the compartment during the previous breath ($C_vO_{2j}[i-1]$), the compartment parameters, and the period of the breath (T_B).

$$\text{For } j = 1 \dots n_{O_2}$$

$$C_vO_2[i] =$$

$$C_vO_2[i-1] + \frac{100 \cdot T_B}{dO_{2j}} \cdot (q_j \cdot Q \cdot (C_aO_2[i] - C_vO_{2j}[i-1]) - vo_{2j} \cdot VO_2)$$

[0241] The values for a one compartment model ($n_{O_2}=1$) are given below. The model assumes a single compartment with a storage capacity for O₂ (dO_{2k}) proportional to the subjects weight (W) (49).

j	q _j	dO _{2j}	vo _{2j}
1	1	(1500/70) · W	1

[0242] The mixed-venous O₂ content leaving the tissues ($C_{MV(T)}O_2[i]$) is the sum of the O₂ content leaving each compartment ($C_vO_2[j][i]$) weighted by the fraction of the cardiac output (q_j) received by the compartment.

$$C_{MV(T)}O_2[i] = \sum_{j=1}^{n_{O_2}} q_j \cdot C_vO_2[j][i]$$

[0243] Alternatively, since the storage capacity of O₂ in the tissues of the body is small, the O₂ content of the mixed-venous blood leaving the tissues ($C_{MV(T)}O_2[i]$) can be assumed to be equal to the arterial inflow of O₂ to the tissues ($Q \cdot C_aO_2[i]$) less the overall metabolic O₂ consumption of the tissues (VO₂) distributed over the cardiac output (Q).

$$C_{MV(T)}O_2[i] = \frac{Q \cdot C_aO_2[i] - VO_2}{Q}$$

[0244] The O₂ content of the mixed-venous blood entering the pulmonary circulation ($C_{MV}O_2[i]$) is equal to the O₂ content of the mixed-venous blood leaving the tissues delayed by the recirculation time ($C_{MV(T)}O_2[i-n_R]$)

$$C_{MV}O_2[i] = C_{MV(T)}O_2[i-n_R]$$

Other O₂ model parameters are available from (49; 50).

Calculate the CO₂ Content of the Mixed-Venous Blood

[0245] Before returning to the venous circulation, the arterial blood passes through the tissue capillary beds where CO₂ is produced and exchanged. This system can be modelled as a compartmental system where each compartment (k) represents a single tissue or group of tissues. Each compartment is assigned a storage capacity for CO₂ (dCO_{2k}). Each compartment is also modelled as being responsible for a fraction (vco_{2k}) of the overall metabolic CO₂ production (VCO₂), and receiving a fraction (q_k) of the total cardiac output (Q). The content of CO₂ in the venous blood leaving a compartment ($C_vCO_2[k][i]$) is equal to the content of CO₂ in the compartment. Assuming a CO₂ model with n_{CO_2} compartments, the CO₂ content of the venous blood leaving each compartment can be calculated from the CO₂ content in the compartment during the previous breath ($C_vCO_2[j][i-1]$), the compartment parameters, and the period of the breath (T_B).

For $k = 1 \dots n_{CO_2}$

$$C_vCO_2[k][i] = C_vCO_2[k][i-1] + \frac{100 \cdot T_B}{dCO_2k} \cdot (vco_2k \cdot VCO_2 - q_k \cdot Q \cdot (C_vCO_2[k][i-1] - C_aCO_2[i]))$$

[0246] The values for a five compartment model ($n_{CO_2}=5$) are given below (51). The model assumes each compartment has a storage capacity for CO₂ (dCO_{2k}) proportional to the subjects weight (W).

k	q _k	dCO _{2k}	vco _{2k}
1	0.04	(225/70) · W	0.11
2	0.14	(902/70) · W	0.28
3	0.16	(9980/70) · W	0.17
4	0.15	(113900/70) · W	0.15
5	0.51	(3310/70) · W	0.29

[0247] The values for a one compartment model ($n_{CO_2}=1$) are given below. The model assumes a single compartment with a storage capacity for CO₂ (dCO_{2k}) proportional to the subjects weight (W). The storage capacity for the single compartment is calculated as the average of the storage capacity for each compartment of the multi-compartment model weighted by the fraction of the cardiac output assigned to the compartment.

k	q _k	dCO _{2k}	vco _{2k}
1	1	(20505/70) · W	1

[0248] The mixed-venous CO₂ content leaving the tissues ($C_{MV(T)}CO_2[i]$) is the sum of the CO₂ content leaving each compartment ($C_vCO_2[k][i]$) weighted by the fraction of the cardiac output (q_k) received by the compartment.

$$C_{MV(T)}CO_2[i] = \sum_{k=1}^{n_{CO_2}} q_k \cdot C_vCO_2[k][i]$$

[0249] The CO₂ content of the mixed-venous blood entering the pulmonary circulation ($C_{MV}CO_2[i]$) is equal to the CO₂ content of the mixed-venous blood leaving the tissues delayed by the recirculation time ($C_{MV(T)}CO_2[i-n_R]$)

$$C_{MV}CO_2[i] = C_{MV(T)}CO_2[i-n_R]$$

[0250] Other CO₂ model parameters are available from (49; 52).

Calculate PIO₂ and PICO₂ to Deliver with No Sequential Gas Delivery Circuit

[0251] On each inspiration, a tidal volume (V_T) of gas is inspired into the alveoli. When the subject is not connected to a sequential gas delivery circuit, gas is inspired in the following order: a) the gas in the anatomical dead space (V_D) is re-inspired with a partial pressure of O₂ equal to the target end-tidal partial pressure of O₂ from the previous breath ($P_{ET}O_2[i-1]^T$) and a partial pressure of CO₂ equal to the target end-tidal partial pressure of CO₂ from the previous breath ($P_{ET}CO_2[i-1]^T$); b) a volume of controlled gas mixture (VG₁) with controllable partial pressure of O₂ ($P_{O_2}[i]$) and controllable partial pressure of CO₂ ($P_{CO_2}[i]$). This inspired gas mixes with the volume of gas in the functional residual capacity (FRC) with a partial pressure of O₂ and CO₂ equal to the target end-tidal partial pressures from the previous breath.

[0252] A volume of O₂ is transferred between the alveolar space and the pulmonary circulation ($VB_{O_2}[i]$). The rate of

O₂ transfer between the alveolar space and the pulmonary circulation depends on the product of the cardiac output (Q) less the intrapulmonary shunt fraction (s), and the difference between the mixed-venous O₂ content entering the pulmonary circulation ($C_{MV}O_2[i]$) and the pulmonary end-capillary O₂ content ($C_pO_2[i]$) leaving the pulmonary circulation. This transfer occurs over the breath period (T_B).

$$VB_{O_2}[i] = Q \cdot (1-s) \cdot T_B \cdot (C_{MV}O_2[i] - C_pO_2[i])$$

[0253] A volume of CO₂ is transferred between the alveolar space and the pulmonary circulation ($VB_{CO_2}[i]$). The rate of CO₂ transfer between the alveolar space and the pulmonary circulation depends on the product of the cardiac output (Q) less the intrapulmonary shunt fraction (s), and the difference between the mixed-venous CO₂ content entering the pulmonary circulation ($C_{MV}CO_2[i]$) and the pulmonary end-capillary CO₂ content ($C_pCO_2[i]$) leaving the pulmonary circulation. This transfer occurs over the breath period (T_B).

$$VB_{CO_2}[i] = Q \cdot (1-s) \cdot T_B \cdot (C_{MV}CO_2[i] - C_pCO_2[i])$$

[0254] The average volume of the controlled gas mixture inspired into the alveoli in each breath (VG_1) is given by the tidal volume (V_T) less the anatomical dead space (V_D).

$$VG_1 = V_T - V_D$$

[0255] The end-tidal partial pressure O₂ ($P_{ET}O_2[i]^T$) is simply the total volume of O₂ in the alveolar space, divided by the total volume of the alveolar space. The end-tidal partial pressure CO₂ ($P_{ET}CO_2[i]^T$) is simply the total volume of CO₂ in the alveolar space, divided by the total volume of the alveolar space.

$$P_{ET}O_2[i]^T = \frac{\left(\frac{\text{O}_2 \text{ in FRC}}{P_{ET}O_2[i-1]^T \cdot FRC + P_{ET}O_2[i-1]^T \cdot V_D} + \frac{\text{O}_2 \text{ re-inspired from } V_D}{P_{ET}O_2[i-1]^T \cdot FRC + P_{ET}O_2[i-1]^T \cdot V_D} + \frac{\text{O}_2 \text{ in controlled gas mixture}}{P_iO_2[i] \cdot (V_T - V_D)} + \frac{\text{O}_2 \text{ transferred into lung from the circulation (} VB_{O_2})}{PB \cdot Q \cdot (1-s) \cdot T_B \cdot (C_{MV}O_2[i] - C_pO_2[i])} \right)}{\frac{V_T + FRC}{\text{Total volume of the alveolar space}}}$$

$$P_{ET}CO_2[i]^T = \frac{\left(\frac{\text{CO}_2 \text{ in FRC}}{P_{ET}CO_2[i-1]^T \cdot FRC + P_{ET}CO_2[i-1]^T \cdot V_D} + \frac{\text{CO}_2 \text{ re-inspired from } V_D}{P_{ET}CO_2[i-1]^T \cdot FRC + P_{ET}CO_2[i-1]^T \cdot V_D} + \frac{\text{CO}_2 \text{ in controlled gas mixture}}{P_iCO_2[i] \cdot (V_T - V_D)} + \frac{\text{CO}_2 \text{ transferred into lung from the circulation (} VB_{CO_2})}{PB \cdot Q \cdot (1-s) \cdot T_B \cdot (C_{MV}CO_2[i] - C_pCO_2[i])} \right)}{\frac{V_T + FRC}{\text{Total volume of the alveolar space}}}$$

[0256] Since all of these volumes and partial pressures are either known, or can be estimated, the partial pressure of O₂ in the controlled gas mixture ($P_iO_2[i]$) and the partial pressure of CO₂ in the controlled gas mixture ($P_iCO_2[i]$) can be set to induce target end-tidal partial pressures.

[0257] In some cases, some of the terms (braced terms in the numerator of the above equations) contributing to the target end-tidal partial pressure of O₂ ($P_{ET}O_2[i]^T$) or the target end-tidal partial pressure of CO₂ ($P_{ET}CO_2[i]^T$) may

be neglected. For example, in most cases, the O₂ or CO₂ re-inspired from the anatomical dead space (V_D) is small compared to the O₂ or CO₂ in the other volumes that contribute to the end-tidal partial pressures. In a case where the volume of O₂ or CO₂ in the controlled gas mixture is very large, for example when trying to induce a large increase in the target end-tidal partial pressures, the O₂ or CO₂ transferred into the lung from the circulation may be comparatively small and neglected. Neglecting any terms of the mass balance equations will decrease computational complexity at the expense of the accuracy of the induced end-tidal partial pressures of gases.

[0258] After re-arranging the above equations for the partial pressure of O₂ in the controlled gas mixture and the partial pressure of CO₂ in the controlled gas mixture, simplification, and grouping of terms:

$$P_iO_2[i] = \frac{P_{ET}O_2[i]^T \cdot (FRC + V_T) - P_{ET}O_2[i-1]^T \cdot (FRC + V_D) - PB \cdot Q \cdot (1-s) \cdot T_B \cdot (C_{MV}O_2[i] - C_pO_2[i])}{(V_T - V_D)}$$

$$P_iCO_2[i] = \frac{P_{ET}CO_2[i]^T \cdot (FRC + V_T) - P_{ET}CO_2[i-1]^T \cdot (FRC + V_D) - PB \cdot Q \cdot (1-s) \cdot T_B \cdot (C_{MV}CO_2[i] - C_pCO_2[i])}{(V_T - V_D)}$$

[0259] These equations can be used to calculate the partial pressure of O₂ in the controlled gas mixture ($P_iO_2[i]$) and the partial pressure of CO₂ in the controlled gas mixture ($P_iCO_2[i]$) required to induce a target end-tidal partial pressure of O₂ ($P_{ET}O_2[i]^T$) and target end-tidal partial pressure of CO₂ ($P_{ET}CO_2[i]^T$) where the target end-tidal partial pressure of O₂ from the previous breath ($P_{ET}O_2[i-1]^T$), the target end-tidal partial pressure of CO₂ from the previous breath ($P_{ET}CO_2[i-1]^T$), the functional residual capacity (FRC), the anatomical dead space (V_D), tidal volume (V_T), the breath period (T_B), cardiac output (Q), intrapulmonary shunt fraction (s), mixed-venous content of O₂ entering the pulmonary circulation ($C_{MV}O_2[i]$), mixed-venous content of CO₂ entering the pulmonary circulation ($C_{MV}CO_2[i]$), pulmonary end-capillary content of O₂ ($C_pO_2[i]$), and pulmonary end-capillary content of CO₂ ($C_pCO_2[i]$) are either known, calculated, estimated, measured, or predicted.

[0260] Notice that the partial pressure of O₂ in the controlled gas mixture ($P_iO_2[i]$) and the partial pressure of CO₂ in the controlled gas mixture ($P_iCO_2[i]$) required to induce a target end-tidal partial pressure of O₂ ($P_{ET}O_2[i]^T$) or a target end-tidal partial pressure of CO₂ ($P_{ET}CO_2[i]^T$) depends strongly on the tidal volume (V_T), anatomical dead space (V_D), and the functional residual capacity (FRC).

[0261] It is often useful in practise to maintain the end-tidal partial pressures of gases steady for a predefined number of breaths or period of time. This is a special case of inducing target end-tidal partial pressures of gases where the target end-tidal partial pressure of a gas in a breath is equal to the target end-tidal partial pressure of said gas from the previous breath.

$$P_{ET}O_2[i]^T = P_{ET}O_2[i-1]^T \text{ OR}$$

$$P_{ET}CO_2[i]^T = P_{ET}CO_2[i-1]^T$$

[0262] Herein, the above general equations for calculating the composition of the controlled gas mixture reduce to the following:

$$P_{iO_2}[i] = \frac{P_{ET}O_2[i]^T \cdot (V_T - V_D) - PB \cdot Q \cdot (1-s) \cdot T_B \cdot (C_{MV}O_2[i] - C_pO_2[i])}{V_T - V_D}$$

$$P_{iCO_2}[i] = \frac{P_{ET}CO_2[i]^T \cdot (V_T - V_D) - PB \cdot Q \cdot (1-s) \cdot T_B \cdot (C_{MV}CO_2[i] - C_pCO_2[i])}{V_T - V_D}$$

[0263] Notice, these equations still require the estimation, measurement, or determination of many of the subject's ventilatory or pulmonary parameters, namely, tidal volume (V_T), functional residual capacity (FRC), breath period (T_B), and anatomical dead space (V_D). Therefore, in the absence of sequential rebreathing, the calculation of the partial pressure of O_2 in the controlled gas mixture ($P_{iO_2}[i]$) and the partial pressure of CO_2 in the controlled gas mixture ($P_{iCO_2}[i]$) required to induce a target end-tidal partial pressure of O_2 ($P_{ET}O_2[i]^T$) and a target end-tidal partial pressure of CO_2 ($P_{ET}CO_2[i]^T$) is highly dependant on the subjects ventilatory and pulmonary parameters. However, some of these parameters, namely functional residual capacity (FRC) and the anatomical dead space (V_D), can be measured or estimated prior to execution of the targeting sequence, and can be reasonably assumed not to change over the course of the experiment. Other parameters, namely tidal volume (V_T) and breath period (T_B), while normally highly variable, are very well controlled and stable in mechanically ventilated subjects.

[0264] This method, therefore, is optional, especially where a simpler approach is preferred, and the subject's ventilation can be reasonably controlled or predicted.

[0265] It will be recognized that the volumes and partial pressures required to calculate the partial pressure of O_2 in the controlled gas mixture ($P_{iO_2}[i]$) and the partial pressure of CO_2 in the controlled gas mixture ($P_{iCO_2}[i]$) may need to be corrected for differences in temperature or presence of water vapour between the lung and the conditions under which they are measured, estimated, or delivered. The corrections applied will depend on the conditions under which these volumes and partial pressures are measured, estimated, or delivered. All volumes and partial pressures should be corrected to body temperature and pressure saturated conditions. A person skilled in the art will be comfortable with these corrections.

[0266] A person skilled in the art will also recognize the equivalence between partial pressures and fractional concentrations. Any terms expressed as partial pressures can be converted to fractional concentrations and vice-versa. For example, the partial pressure of O_2 in the controlled gas mixture ($P_{iO_2}[i]$) and the partial pressure of CO_2 in the controlled gas mixture ($P_{iCO_2}[i]$) may be converted a fractional concentration of O_2 in the controlled gas mixture ($F_{iO_2}[i]$) and a fractional concentration of CO_2 in the controlled gas mixture ($F_{iCO_2}[i]$).

$$F_{iO_2}[i] = \frac{P_{iO_2}[i]}{PB}$$

-continued

$$F_{iCO_2}[i] = \frac{P_{iCO_2}[i]}{PB}$$

Calculate PIO₂ and PICO₂ to Deliver to a Sequential Gas Delivery Circuit

[0267] On each inspiration, a tidal volume (V_T) of gas is inspired into the alveoli. When the subject is connected to a sequential gas delivery circuit (SGDC) that collects previously expired gas in a reservoir for later inspiration as neutral gas (ex. Hi-Ox_{SR}), gas is inspired in the following order: a) the gas in the anatomical dead space (V_D) is re-inspired with a partial pressure of O_2 equal to the target end-tidal partial pressure of O_2 from the previous breath ($P_{ET}O_2[i-1]^T$) and a partial pressure of CO_2 equal to the target end-tidal partial pressure of CO_2 from the previous breath ($P_{ET}CO_2[i-1]^T$); b) a volume of controlled gas mixture (VG_1) with controllable partial pressure of O_2 ($P_{iO_2}[i]$) and controllable partial pressure of CO_2 ($P_{iCO_2}[i]$); c) a volume of neutral gas (VG_2) with a partial pressure of O_2 and CO_2 equal to the target end-tidal partial pressures from the previous breath. This inspired gas mixes with the volume of gas in the functional residual capacity (FRC) with a partial pressure of O_2 and CO_2 equal to the target end-tidal partial pressures from the previous breath.

[0268] A volume of O_2 is transferred between the alveolar space and the pulmonary circulation ($VB_{O_2}[i]$). The rate of O_2 transfer between the alveolar space and the pulmonary circulation depends on the product of the cardiac output (Q) less the intrapulmonary shunt fraction (s), and the difference between the mixed-venous O_2 content entering the pulmonary circulation ($C_{MV}O_2[i]$) and the pulmonary end-capillary O_2 content ($C_pO_2[i]$) leaving the pulmonary circulation. This transfer occurs over the breath period (T_B).

$$VB_{O_2}[i] = Q \cdot (1-s) \cdot T_B \cdot (C_{MV}O_2[i] - C_pO_2[i])$$

[0269] A volume of CO_2 is transferred between the alveolar space and the pulmonary circulation ($VB_{CO_2}[i]$). The rate of CO_2 transfer between the alveolar space and the pulmonary circulation depends on the product of the cardiac output (Q) less the intrapulmonary shunt fraction (s), and the difference between the mixed-venous CO_2 content entering the pulmonary circulation ($C_{MV}CO_2[i]$) and the pulmonary end-capillary CO_2 content ($C_pCO_2[i]$) leaving the pulmonary circulation. This transfer occurs over the breath period (T_B).

$$VB_{CO_2}[i] = Q \cdot (1-s) \cdot T_B \cdot (C_{MV}CO_2[i] - C_pCO_2[i])$$

[0270] Assuming a neutral gas at least fills the subject's anatomical dead space (V_D), the average volume of the controlled gas mixture inspired into the alveoli in each breath (VG_1) is given by the rate at which the controlled gas mixture is made available for inspiration (FG_1) delivered over a single breath period (T_B):

$$VG_1 = FG_1 \cdot T_B$$

[0271] The average volume of neutral gas that is inspired into the alveoli in each breath is given by the tidal volume (V_T) less the volume of inspired controlled gas mixture (VG_1) and the volume of gas that remains in the anatomical dead space (V_D):

$$VG_2 = V_T - V_D - VG_1 \cdot T_B$$

[0272] The end-tidal partial pressure O₂ ($P_{ET}O_2[i]^T$) is simply the total volume of O₂ in the alveolar space, divided by the total volume of the alveolar space. The end-tidal partial pressure CO₂ ($P_{ET}CO_2[i]^T$) is simply the total volume of CO₂ in the alveolar space, divided by the total volume of the alveolar space.

$$P_{ET}O_2[i]^T = \frac{\left(\begin{array}{l} \text{O}_2 \text{ re-inspired} \\ \text{O}_2 \text{ in FRC} \quad \text{from } V_D \\ \frac{P_{ET}O_2[i-1]^T \cdot FRC + P_{ET}O_2[i-1]^T \cdot V_D +}{\text{O}_2 \text{ in controlled}} \\ \text{gas mixture} \quad \text{O}_2 \text{ in neutral gas} \\ \frac{P_iO_2[i] \cdot (FG_1 \cdot T_B) + P_{ET}O_2[i-1]^T \cdot (V_T - V_D - FG_1 \cdot T_B) +}{\text{O}_2 \text{ transferred into lung}} \\ \text{from the circulation (VB}_{O_2}) \\ \frac{PB \cdot Q \cdot (1-s) \cdot T_B \cdot (C_{MV}O_2[i] - C_pO_2[i])}{V_T + FRC} \end{array} \right)}{\text{Total volume of the alveolar space}}$$

$$P_{ET}CO_2[i]^T = \frac{\left(\begin{array}{l} \text{CO}_2 \text{ re-inspired} \\ \text{CO}_2 \text{ in FRC} \quad \text{from } V_D \\ \frac{P_{ET}CO_2[i-1]^T \cdot FRC + P_{ET}CO_2[i-1]^T \cdot V_D +}{\text{CO}_2 \text{ in controlled}} \\ \text{gas mixture} \quad \text{CO}_2 \text{ in neutral gas} \\ \frac{P_iCO_2[i] \cdot (FG_1 \cdot T_B) + P_{ET}CO_2[i-1]^T \cdot (V_T - V_D - FG_1 \cdot T_B) +}{\text{CO}_2 \text{ transferred into lung}} \\ \text{from the circulation (VB}_{CO_2}) \\ \frac{PB \cdot Q \cdot (1-s) \cdot T_B \cdot (C_{MV}CO_2[i] - C_pCO_2[i])}{V_T + FRC} \end{array} \right)}{\text{Total volume of the alveolar space}}$$

[0273] Since all of these volumes and partial pressures are either known, or can be estimated, the partial pressure of O₂ in the controlled gas mixture ($P_iO_2[i]$) and the partial pressure of CO₂ in the controlled gas mixture ($P_iCO_2[i]$) can be set to induce target end-tidal partial pressures.

[0274] In some cases, some of the terms (braced terms in the numerator of the above equations) contributing to the target end-tidal partial pressure of O₂ ($P_{ET}O_2[i]^T$) or the target end-tidal partial pressure of CO₂ ($P_{ET}CO_2[i]^T$) may be neglected. For example, in most cases, the O₂ or CO₂ re-inspired from the anatomical dead space (V_D) is small compared to the O₂ or CO₂ in the other volumes that contribute to the end-tidal partial pressures. In the case where the volume of O₂ or CO₂ in the controlled gas mixture is very large, for example when trying to induce a large increase in the target end-tidal partial pressures, the O₂ or CO₂ transferred into the lung from the circulation may be comparatively small and neglected. Neglecting any terms of the mass balance equations will decrease computational complexity at the expense of the accuracy of the induced end-tidal partial pressures of gases.

[0275] After re-arranging the above equations for the partial pressure of O₂ in the controlled gas mixture and the partial pressure of CO₂ in the controlled gas mixture, simplification, and grouping of terms:

$$P_iO_2[i] = \frac{(P_{ET}O_2[i]^T - P_{ET}O_2[i-1]^T) \cdot (FRC + V_T) + P_{ET}O_2[i-1]^T \cdot (FG_1 \cdot T_B) - PB \cdot Q \cdot (1-s) \cdot T_B \cdot (C_{MV}O_2[i] - C_pO_2[i])}{FG_1 \cdot T_B}$$

-continued

$$P_iCO_2[i] = \frac{(P_{ET}CO_2[i]^T - P_{ET}CO_2[i-1]^T) \cdot (FRC + V_T) + P_{ET}CO_2[i-1]^T \cdot (FG_1 \cdot T_B) - PB \cdot Q \cdot (1-s) \cdot T_B \cdot (C_{MV}CO_2[i] - C_pCO_2[i])}{FG_1 \cdot T_B}$$

[0276] The above equations can be used to calculate the partial pressure of O₂ in the controlled gas mixture ($P_iO_2[i]$) and the partial pressure of CO₂ in the controlled gas mixture ($P_iCO_2[i]$) required to induce a target end-tidal target partial pressure of O₂ ($P_{ET}O_2[i]^T$) and a target end-tidal partial pressure of CO₂ ($P_{ET}CO_2[i]^T$) where the target end-tidal partial pressure of O₂ from the previous breath ($P_{ET}O_2[i-1]^T$), the target end-tidal partial pressure of CO₂ from the previous breath ($P_{ET}CO_2[i-1]^T$), the functional residual capacity (FRC), tidal volume (V_T), rate at which the controlled gas mixture is made available for inspiration (FG_1), the breath period (T_B), cardiac output (Q), intrapulmonary shunt fraction (s), recirculation time (n_R), mixed-venous content of O₂ entering the pulmonary circulation ($C_{MV}O_2[i]$), mixed-venous content of CO₂ entering the pulmonary circulation ($C_{MV}CO_2[i]$), pulmonary end-capillary content of O₂ ($C_pO_2[i]$), and pulmonary end-capillary content of CO₂ ($C_pCO_2[i]$) are either known, calculated, estimated, measured, or predicted.

[0277] Notice that where this form sequential rebreathing is employed, the anatomical dead space (V_D) does not factor into the above equations and end-tidal targeting is independent of its measurement or estimation. Notice also that the tidal volume (V_T) appears only in summation with the functional residual capacity (FRC). Since the tidal volume is, in general, small compared to the functional residual capacity ($V_T \leq 0.1 \cdot \text{FRC}$), errors in measurement or estimation of the tidal volume have little effect on inducing target end-tidal partial pressures of gases. In fact, the above equations can be used with the tidal volume term omitted completely with little effect on results.

[0278] It is often useful in practise to maintain the end-tidal partial pressures of gases steady for a predefined number of breaths or period of time. This is a special case of inducing target end-tidal partial pressures of gases where the target end-tidal partial pressure of a gas in a breath is equal to the target end-tidal partial pressure of said gas from the previous breath.

$$P_{ET}O_2[i]^T = P_{ET}O_2[i-1]^T \text{ OR}$$

$$P_{ET}CO_2[i]^T = P_{ET}CO_2[i-1]^T$$

[0279] Herein, the above general equations for calculating the composition of the controlled gas mixture reduce to the following:

$$P_iO_2[i] = \frac{P_{ET}O_2[i]^T \cdot FG_1 - PB \cdot Q \cdot (1-s) \cdot (C_{MV}O_2[i] - C_pO_2[i])}{FG_1}$$

$$P_iCO_2[i] = \frac{P_{ET}CO_2[i]^T \cdot FG_1 - PB \cdot Q \cdot (1-s) \cdot (C_{MV}CO_2[i] - C_pCO_2[i])}{FG_1}$$

[0280] Notice, these equations do not require the estimation, measurement, or determination of any of the subject's ventilatory or pulmonary parameters, namely, tidal volume (V_T), functional residual capacity (FRC), breath period (T_B), or anatomical dead space (V_D).

[0281] The reduced or eliminated sensitivity of the equations to the subject's ventilatory parameters makes this method useful in practise with spontaneously breathing subjects. It is, however, not limited to spontaneously breathing subjects, and may also be used in mechanically ventilated subjects.

[0282] A person skilled in the art will recognize that the volumes and partial pressures required to calculate the partial pressure of O₂ in the controlled gas mixture ($P_iO_2[i]$) and the partial pressure of CO₂ in the controlled gas mixture ($P_iCO_2[i]$) may need to be corrected for differences in temperature or presence of water vapour between the lung and the conditions under which they are measured, estimated, or delivered. The corrections applied will depend on the conditions under which these volumes and partial pressures are measured, estimated, or delivered. All volumes and partial pressures should be corrected to body temperature and pressure saturated conditions. A person skilled in the art will be comfortable with these corrections.

[0283] A person skilled in the art will also recognize the equivalence between partial pressures and fractional concentrations. Any terms expressed as partial pressures can be converted to fractional concentrations and vice-versa. For example, the partial pressure of O₂ in the controlled gas mixture ($P_iO_2[i]$) and the partial pressure of CO₂ in the controlled gas mixture ($P_iCO_2[i]$) may be converted a

fractional concentration of O₂ in the controlled gas mixture ($F_iO_2[i]$) and a fractional concentration of CO₂ in the controlled gas mixture ($F_iCO_2[i]$).

$$F_iO_2[i] = \frac{P_iO_2[i]}{PB}$$

$$F_iCO_2[i] = \frac{P_iCO_2[i]}{PB}$$

Determine if Targets are Logistically Feasible

[0284] In practise, many different implementations of gas delivery devices and sequential gas delivery circuits may be used. In general, it is logistically feasible to induce the target end-tidal partial pressures for the current breath ($P_{ET}O_2[i]^T$, $P_{ET}CO_2[i]^T$) if:

1) The required partial pressures of gases in the controlled gas mixture are physically realizable:

$$0 \leq P_iO_2[i] \leq PB \quad \text{a)}$$

$$0 \leq P_iCO_2[i] \leq PB \quad \text{b)}$$

$$P_iO_2[i] + P_iCO_2[i] \leq PB \quad \text{c)}$$

2) The gas delivery device is capable of delivering a controlled mixture of the desired composition at the required flow rate

Where Sequential Rebreathing is Carried Out with a Hi-Ox_{SR} Sequential Gas Delivery Circuit and a Gas Blender:

[0285] Assuming n_{SG} source gases ($SG_1 \dots SG_{n_{SG}}$) are blended to deliver the required mixture to the Hi-Ox_{SR} sequential gas delivery circuit (SGDC). Each gas (m) contains a known fractional concentration of O₂ (fo_{2_m}) and a known fractional concentration of CO₂ (fco_{2_m}). The flow rate of each gas ($FSG_m[i]$) required to deliver the total desired flow rate of the controlled gas (FG_1) with the required partial pressure of O₂ ($P_iO_2[i]$) and the required partial pressure of CO₂ ($P_iCO_2[i]$) can be determined by solving the following set of equations:

$$\sum_{m=1}^{n_{SG}} FSG_m[i] = FG_1$$

$$\sum_{m=1}^{n_{SG}} fo_{2_m} \cdot FSG_m[i] = \frac{P_iO_2[i]}{PB} \cdot FG_1$$

$$\sum_{m=1}^{n_{SG}} fco_{2_m} \cdot FSG_m[i] = \frac{P_iCO_2[i]}{PB} \cdot FG_1$$

[0286] The target end-tidal partial pressures for the current breath ($P_{ET}O_2[i]^T$, $P_{ET}CO_2[i]^T$) are logistically feasible if:

$$1) 0 \leq P_iO_2[i] \leq PB$$

$$2) 0 \leq P_iCO_2[i] \leq PB$$

$$3) P_iO_2[i] + P_iCO_2[i] \leq PB$$

4) There exists a solution to the above system of equations, and

$$5) FSG_m[i] \geq 0 \forall m$$

6) The gas blender is capable of delivering a controlled mixture of the desired composition at the required flow rate [0287] It is therefore required that $n_{SG} \geq 3$. It is computationally optimal to have $n_{SG} = 3$.

[0288] One possible set of gases is:

SG₁: fco₂₁=0, fo₂₁=1

SG₂: fco₂₂=1, fo₂₂=0

SG₃: fco₂₃=0, fo₂₃=0

[0289] It may enhance the safety of the system to use gases with a minimal concentration of O₂ and maximum concentration of CO₂. In this case, a possible set of gases is:

SG₁: fco₂₁=0, fo₂₁=0.1

SG₂: fco₂₂=0.4, fo₂₂=0.1

SG₃: fco₂₃=0, fo₂₃=1

[0290] The balance of the source gases when not entirely composed of O₂ and CO₂ can be made up of any gas or combination of gases, which may vary depending on the context. The balance of the source gases is most often made up of N₂ because it is physiologically inert.

Adjusting Parameters to Make Logistically Infeasible Targets Logistically Feasible:

[0291] It may occur that inducing a target end-tidal partial pressure of O₂ ($P_{ET}O_2[i]^T$) or a target end-tidal partial pressure of CO₂ ($P_{ET}CO_2[i]^T$) in a given breath is not logistically feasible. This may occur because the partial pressure of O₂ in the controlled gas mixture ($P_fO_2[i]$) or the partial pressure of CO₂ in the controlled gas mixture ($P_fCO_2[i]$) required to induce the target end-tidal partial pressure of O₂ or the target end-tidal partial pressure of CO₂ is either not physically realizable, or there does not exist a blend of the current source gases (SG₁ . . . SG_{n_G}) resulting in the required the partial pressure of O₂ in the controlled gas mixture and the required partial pressure of CO₂ in the controlled gas mixture. If the composition of the controlled gas mixture is not physically realizable for a given set of targets, the targets may be modified and/or the rate at which the controlled gas mixture is made available to the circuit (FG₁) modified, or where applicable, the tidal volume (V_T) modified, until the composition is physically realizable. If the composition of the controlled gas mixture is physically realizable for a given set of targets, but no combination of the source gases results in the required composition, the targets may be modified and/or the rate at which the controlled gas mixture is made available to the circuit modified, or where applicable, the tidal volume (V_T) modified, and/or different source gases used.

[0292] If $P_fO_2[i] < 0$ —The target end-tidal partial pressure of O₂ ($P_{ET}O_2[i]^T$) is not logistically feasible because the partial pressure of O₂ in the controlled gas mixture ($P_fO_2[i]$) required to induce the target end-tidal partial pressure of O₂ is not physically realizable. To make induction of the target logistically feasible, increase the target end-tidal partial pressure of O₂. Alternatively, where sequential rebreathing is used, the rate at which the controlled gas mixture is made available to the circuit (FG₁) may be modified. Where sequential rebreathing is not used, the tidal volume (V_T) may be modified.

[0293] If $P_fO_2[i] > PB$ —The target end-tidal partial pressure of O₂ ($P_{ET}O_2[i]^T$) is not logistically feasible because the partial pressure of O₂ in the controlled gas mixture ($P_fO_2[i]$) required to induce the target end-tidal partial pressure of O₂ is not physically realizable. To make induction of the target logistically feasible, decrease the target

end-tidal partial pressure of O₂. Alternatively, where sequential rebreathing is used, the rate at which the controlled gas mixture is made available to the circuit (FG₁) may be modified. Where sequential rebreathing is not used, the tidal volume (V_T) may be modified.

[0294] If $P_fCO_2[i] < 0$ —The target end-tidal partial pressure of CO₂ ($P_{ET}CO_2[i]^T$) is not logistically feasible because the partial pressure of CO₂ in the controlled gas mixture ($P_fCO_2[i]$) required to induce the target end-tidal partial pressure of CO₂ is not physically realizable. To make induction of the target logistically feasible, decrease the target end-tidal partial pressure of CO₂. Alternatively, where sequential rebreathing is used, the rate at which the controlled gas mixture is made available to the circuit (FG₁) may be modified. Where sequential rebreathing is not used, the tidal volume (V_T) may be modified.

[0295] If $P_fCO_2[i] > PB$ —The target end-tidal partial pressure of CO₂ ($P_{ET}CO_2[i]^T$) is not logistically feasible because the partial pressure of CO₂ in the controlled gas mixture ($P_fCO_2[i]$) required to induce the target end-tidal partial pressure of CO₂ is not physically realizable. To make induction of the target logistically feasible, decrease the target end-tidal partial pressure of CO₂. Alternatively, where sequential rebreathing is used, the rate at which the controlled gas mixture is made available to the circuit (FG₁) may be modified. Where sequential rebreathing is not used, the tidal volume (V_T) may be modified.

[0296] If $P_fO_2[i] + P_fCO_2[i] > PB$ —The combination of the target end-tidal partial pressure of O₂ ($P_{ET}O_2[i]^T$) and the target end-tidal partial pressure of CO₂ ($P_{ET}CO_2[i]^T$) is not logistically feasible because the combination of the partial pressure of O₂ in the controlled gas mixture ($P_fO_2[i]$) and the partial pressure of CO₂ in the controlled gas mixture ($P_fCO_2[i]$) required to induce the targets is not physically realizable. To make induction of the targets logistically feasible, decrease the target end-tidal partial pressure of O₂ and/or the target end-tidal partial pressure of CO₂. Alternatively, where sequential rebreathing is used, the rate at which the controlled gas mixture is made available to the circuit (FG₁) may be modified. Where sequential rebreathing is not used, the tidal volume (V_T) may be modified.

[0297] If there does not exist a solution to the above system of equations, or there exists a solution for which $FSG_{n_m}[i] < 0$ for any m, then the current source gases (SG₁ . . . SG_{n_G}) cannot be blended to create the controlled gas mixture. Different source gases must be used to induce the end-tidal target of O₂ ($P_{ET}O_2[i]^T$) and the end-tidal target of CO₂ ($P_{ET}CO_2[i]^T$), or the desired targets must be changed. Alternatively, it may be possible to modify the rate at which the controlled gas mixture is made available to the circuit (FG₁) until the partial pressure of O₂ in the controlled gas mixture ($P_fO_2[i]$) and the partial pressure of CO₂ in the controlled gas mixture ($P_fCO_2[i]$) required to induce the targets are realizable with the current source gases.

[0298] Often, the rate at which the controlled gas mixture is made available to the circuit (FG₁) is modified to make a target end-tidal partial pressure of O₂ ($P_{ET}O_2[i]^T$) or a target end-tidal partial pressure of CO₂ ($P_{ET}CO_2[i]^T$) logistically feasible to induce. However, the rate at which the controlled gas mixture is made available to the circuit should not be increased to a rate beyond which the subject fails to consistently exhaust the supply of the controlled gas mixture in each breath. This maximal rate varies between subjects. However, it is not necessary that the rate at which the

controlled gas mixture is made available to the circuit be the same in every breath. Therefore, the rate at which the controlled gas mixture is made available to the circuit may be set to some basal value for most breaths, and only increased in particular breaths in which the inducing the target end-tidal partial pressures is not logistically feasible at the basal rate of flow. The basal rate at which the controlled gas mixture is made available to the circuit should be a rate at which the subject can comfortably, without undo ventilatory effort, exhaust the supply of the controlled gas mixture in each breath. The maximal rate at which the controlled gas mixture is made available to the circuit should be the maximum rate at which the subject can consistently exhaust the supply of the controlled gas mixture in each breath with a maximal ventilatory effort. The subject may be prompted to increase their ventilatory effort in breaths where the rate at which the controlled gas mixture is made available to the circuit is increased.

Initializing the System

[0299] Let the index [0] represent the value of a variable for all breaths before the start of the sequence (all values of $i \leq 0$). To initialize the system, the subject is allowed to breathe freely, without intervention, until the measured end-tidal partial pressure of O₂ ($P_{ET}CO_2^M$) and the measured end-tidal partial pressure of CO₂ ($P_{ET}CO_2^M$) are stable—these are taken as the baseline partial pressure of O₂ ($P_{ET}O_2^M$) and the baseline partial pressure of CO₂ ($P_{ET}CO_2^M$). The measured end-tidal partial pressures are considered stable when there is less than ± 5 mmHg change in the measured end-tidal partial pressure of O₂ and less than ± 2 mmHg change in the measured end-tidal partial pressure of CO₂ over 3 consecutive breaths. The rest of the variables are initialized by assuming the whole system has equilibrated to a steady state at the baseline end-tidal partial pressures.

Assume that End-Tidal Partial Pressures are Equal to the Baseline Measurements:

$$P_{ET}O_2[0]^T = P_{ET}O_2^M$$

$$P_{ET}CO_2[0]^T = P_{ET}CO_2^M$$

Assume Pulmonary End-Capillary Partial Pressures are Equal to End-Tidal Partial Pressures:

[0300]

$$P_pO_2[0] = P_{ET}O_2[0]^T$$

$$P_pCO_2[0] = P_{ET}CO_2[0]^T$$

Calculate O₂ Blood Contents Assuming Steady State:

Pulmonary End-Capillary O₂ Saturation:

[0301]

$$pH[0] = 6.1 + \log\left(\frac{[HCO_3^-]}{0.03 \cdot P_pCO_2[0]}\right)$$

$$S_pO_2[0] =$$

$$100 \cdot \frac{-8532.2289 \cdot z + 2121.401 \cdot z^2 - 67.073989 \cdot z^3 + z^4}{935960.87 - 31346.258 \cdot z + 2396.1674 \cdot z^2 - 67.104406 \cdot z^3 + z^4}$$

-continued

where

$$z = P_pO_2[0] \cdot 10^{0.024 \cdot (37-T) + 0.4 \cdot (pH[0] - 7.4) + 0.06 \cdot (\log 40 - \log P_pCO_2[0])}$$

Pulmonary End-Capillary O₂ Content:

[0302]

$$C_pO_2[0] = 1.36 \cdot Hb \cdot \frac{S_pO_2[0]}{100} + 0.003 \cdot P_pO_2[0]$$

Mixed-Venous O₂ Content:

[0303]

$$C_{MV(T)}O_2[0] = C_pO_2[0] - \frac{VO_2}{(1-s) \cdot Q}$$

$$C_{MV}O_2[0] = C_{MV(T)}O_2[0]$$

Arterial O₂ Content:

[0304]

$$C_aO_2[0] = (1-s) \cdot C_pO_2[0] + s \cdot C_{MV}O_2[0]$$

O₂ Content of Each Compartment in the Model:

[0305]

For $j = 1 \dots n_{O_2}$

$$C_vO_{2j}[0] = C_aO_2[0] - \frac{vo_{2j} \cdot VO_2}{q_j \cdot Q}$$

Calculate CO₂ Blood Contents Assuming Steady State:

Pulmonary End-Capillary CO₂ Content:

[0306]

$$C_pCO_2[0] = \left(1.0 - \frac{0.02924 \cdot Hb}{\left(2.244 - 0.422 \cdot \left(\frac{S_pO_2[0]}{100}\right)\right) \cdot (8.740 - pH[0])}\right) \cdot C_{pl}$$

$$C_{pl} = 0.0301 \cdot P_pCO_2[0] \cdot (1 + 10^{pH[0] - 6.10}) \cdot 2.226$$

Mixed-Venous CO₂ Content:

[0307]

$$C_{MV(T)}CO_2[0] = C_pCO_2[0] + \frac{VCO_2}{(1-s) \cdot Q}$$

$$C_{MV}CO_2[0] = C_{MV(T)}CO_2[0]$$

Arterial CO2 Content:

[0308]

$$C_a\text{CO}_2[0] = (1-s) \cdot C_p\text{CO}_2[0] + s \cdot C_M\text{CO}_2[0]$$

CO2 Content of Each Compartment in the Model:

[0309]

For $k = 1 \dots n_{\text{CO}_2}$

$$C_V\text{CO}_2[k][0] = C_a\text{CO}_2[0] + \frac{v_{\text{CO}_2k} \cdot V\text{CO}_2}{q_k \cdot Q}$$

Tuning the System

[0310] The parameters of the system can be tuned so that the measured end-tidal partial pressures of O2 ($P_{ET}\text{O}_2[i]^M$) and the measured end-tidal partial pressures of CO2 ($P_{ET}\text{CO}_2[i]^M$) during any sequence more closely reflect the target end-tidal partial pressures of O2 ($P_{ET}\text{O}_2[i]^T$) and target end-tidal partial pressures of CO2 ($P_{ET}\text{CO}_2[i]^T$). To tune the system parameters, standardized tuning sequences are run and the measured results compared to the targets. The difference between measured end-tidal partial pressures and the target end-tidal partial pressures in the standardized tuning sequences can be used to refine the estimates of some physiological parameters.

Example Tuning Sequence:

[0311] The tuning sequence sets the target end-tidal partial pressure of O2 ($P_{ET}\text{O}_2[i]^T$) at 5 mmHg above the baseline end-tidal partial pressure of O2 ($P_{ET}\text{O}_2[0]^M$) throughout the sequence, and executes a 5 mmHg step-change in the end-tidal partial pressure of CO2 ($P_{ET}\text{CO}_2[i]^T$) from 5 mmHg above the baseline end-tidal partial pressure of CO2 ($P_{ET}\text{CO}_2[0]^M$) to 10 mmHg above the baseline end-tidal partial pressure of CO2 in breath 30 ($i=30$) of the sequence.

$$P_{ET}\text{O}_2[i]^T = P_{ET}\text{O}_2[0]^M + 5 \quad i=1 \dots 60$$

$$P_{ET}\text{CO}_2[i]^T = P_{ET}\text{CO}_2[0]^M + 5 \quad i=1 \dots 29$$

$$P_{ET}\text{CO}_2[i]^T = P_{ET}\text{CO}_2[0]^M + 10 \quad i=30 \dots 60$$

[0312] The estimate of the functional residual capacity (FRC) can be refined as a function of the difference between the actual step change induced in the end-tidal CO2 ($P_{ET}\text{CO}_2[30]^M - P_{ET}\text{CO}_2[29]^M$) and the target step-change ($P_{ET}\text{CO}_2[30]^T - P_{ET}\text{CO}_2[29]^T = 5$) in breath 30 ($i=30$).

$$\text{FRC} = \text{FRC}_0 + \alpha \left(\frac{P_{ET}\text{CO}_2[30]^M - P_{ET}\text{CO}_2[29]^M}{P_{ET}\text{CO}_2[30]^T - P_{ET}\text{CO}_2[29]^T} \right) -$$

[0313] $\alpha = 200$ ml/mmHg

[0314] In general, the correction factor (α) can range from 50-500 ml/mmHg. Lower values of the correction factor will produce a more accurate estimate of the functional residual capacity (FRC) while requiring more tuning iterations. Higher values will reduce the number of tuning iterations but may cause the refined estimate of the parameter to oscillate around the optimal value.

[0315] The estimate of the overall metabolic O2 consumption (VO_2) can be refined as a function of the difference between the target end-tidal partial pressure of O2 ($P_{ET}\text{O}_2$

$[60]^T$) and the measured end-tidal partial pressure of O2 ($P_{ET}\text{O}_2[60]^M$) in breath 60 ($i=60$).

$$\text{VO}_2 = \text{VO}_2[0] - \beta \left(\frac{P_{ET}\text{O}_2[60]^M - P_{ET}\text{O}_2[60]^T}{P_{ET}\text{O}_2[60]^T} \right) \quad \beta=10$$

ml/min/mmHg

[0316] In general, the correction factor (β) can range from 5-200 ml/min/mmHg. Lower values of the correction factor will produce a more accurate estimate of the overall metabolic O2 consumption (VO_2) while requiring more tuning iterations. Higher values will reduce the number of tuning iterations but may cause the refined estimate of the parameter to oscillate around the optimal value.

[0317] The estimate of the overall metabolic CO2 production (VCO_2) can be refined as a function of the difference between the target end-tidal partial pressure of CO2 ($P_{ET}\text{CO}_2[29]^T$) and the measured end-tidal partial pressure of CO2 ($P_{ET}\text{CO}_2[29]^M$) in breath 29 ($i=29$).

$$\text{VCO}_2 = \text{VCO}_2[0] + \gamma \left(\frac{P_{ET}\text{CO}_2[29]^M - P_{ET}\text{CO}_2[29]^T}{P_{ET}\text{CO}_2[29]^T} \right) \quad \gamma=10$$

ml/min/mmHg

[0318] Alternatively, the estimate of the overall metabolic CO2 production (VCO_2) can be refined as a function of the difference between the target end-tidal partial pressure of CO2 ($P_{ET}\text{CO}_2[60]^T$) and the measured end-tidal partial pressure of CO2 ($P_{ET}\text{CO}_2[60]^M$) in breath 60 ($i=60$).

$$\text{VCO}_2 = \text{VCO}_2[0] + \gamma \left(\frac{P_{ET}\text{CO}_2[60]^M - P_{ET}\text{CO}_2[60]^T}{P_{ET}\text{CO}_2[60]^T} \right) \quad \gamma=10$$

ml/min/mmHg

[0319] In general, the correction factor (γ) can range from 5-200 ml/min/mmHg. Lower values of the correction factor will produce a more accurate estimate of the overall metabolic CO2 production (VCO_2) while requiring more tuning iterations. Higher values will reduce the number of tuning iterations but may cause the refined estimate of the parameter to oscillate around the optimal value.

General Requirements of a Tuning Sequence:

[0320] In breaths where the target end-tidal partial pressures of gases are transitioning between values, the estimate of the functional residual capacity (FRC) determines the magnitude of the change induced in the actual end-tidal partial pressures of gases. The estimate of the overall metabolic O2 consumption (VO_2) influences the induced/measured end-tidal partial pressure of O2 ($P_{ET}\text{O}_2[i]^M$) in steady state. Similarly, the estimate of the overall metabolic CO2 production (VCO_2) influences the induced/measured end-tidal partial pressure of CO2 ($P_{ET}\text{CO}_2[i]^M$) in steady state.

[0321] It therefore follows that a difference between the measured change in the end-tidal partial pressure of O2 ($P_{ET}\text{O}_2[i]^M - P_{ET}\text{O}_2[i-1]^M$) and the targeted change in the end-tidal partial pressure of O2 ($P_{ET}\text{O}_2[i]^T - P_{ET}\text{O}_2[i-1]^T$) in breaths where the target end-tidal partial pressure of O2 is not equal to the target end-tidal partial pressure of O2 from the previous breath ($P_{ET}\text{O}_2[i]^T \neq P_{ET}\text{O}_2[i-1]^T$), or a difference between the measured change in the end-tidal partial pressure of CO2 ($P_{ET}\text{CO}_2[i]^M - P_{ET}\text{CO}_2[i-1]^M$) and the targeted change in the end-tidal partial pressure of CO2 ($P_{ET}\text{CO}_2[i]^T - P_{ET}\text{CO}_2[i-1]^T$) in breaths where the target end-tidal partial pressure of CO2 is not equal to the target end-tidal partial pressure of CO2 from the previous breath ($P_{ET}\text{CO}_2[i]^T \neq P_{ET}\text{CO}_2[i-1]^T$), reflect errors in the estimate of the functional residual capacity (FRC).

[0322] Conversely, differences between the target end-tidal partial pressure of O2 ($P_{ET}\text{O}_2[i]^T$) and the measured

end-tidal partial pressure of O₂ ($P_{ET}O_2[i]^M$) in breaths at the end of a long (20 breath) period of constant target end-tidal partial pressures of O₂ ($P_{ET}O_2[i]^T=P_{ET}O_2[i-1]^T$) reflect errors in the overall metabolic O₂ consumption (VO₂). It is assumed that the measured end-tidal partial pressures of O₂ will have stabilized (less than ± 5 mmHg change in the measured end-tidal partial pressure of O₂ over 3 consecutive breaths), although not necessarily at the target end-tidal partial pressure of O₂, after 20 breaths of targeting the same end-tidal partial pressures of O₂. If, however, the measured end-tidal partial pressure of O₂ has not stabilized after 20 breaths of targeting the same end-tidal partial pressures of O₂, a longer duration of targeting the same end-tidal partial pressure of O₂ should be used for tuning the overall metabolic consumption of O₂.

[0323] Differences between the target end-tidal partial pressure of CO₂ ($P_{ET}CO_2[i]^T$) and the measured end-tidal partial pressure of CO₂ ($P_{ET}CO_2[i]^M$) in breaths at the end of a long (20 breath) period of constant target end-tidal partial pressures of CO₂ ($P_{ET}CO_2[i]^T=P_{ET}CO_2[i-1]^T$) reflect errors in the overall metabolic CO₂ production (VCO₂). It is assumed that the measured end-tidal partial pressures of CO₂ will have stabilized (less than ± 2 mmHg change in the measured end-tidal partial pressure of CO₂ over 3 consecutive breaths), although not necessarily at the target end-tidal partial pressure of CO₂, after 20 breaths of targeting the same end-tidal partial pressures of CO₂. If, however, the measured end-tidal partial pressure of CO₂ has not stabilized after 20 breaths of targeting the same end-tidal partial pressures of CO₂, a longer duration of targeting the same end-tidal partial pressure of CO₂ should be used for tuning the overall metabolic production of CO₂.

[0324] The tuning sequence described above is only an example of one sequence that can be used to tune the estimates of the physiological parameters.

[0325] The functional residual capacity (FRC) can be tuned by observing the difference between the measured change in the end-tidal partial pressure of O₂ ($P_{ET}O_2[i]^M - P_{ET}O_2[i-1]^M$) and the targeted change in the end-tidal partial pressure of O₂ ($P_{ET}O_2[i]^T - P_{ET}O_2[i-1]^T$) in breaths where the target end-tidal partial pressure of O₂ is not equal to the target end-tidal partial pressure of O₂ from the previous breath ($P_{ET}O_2[i]^T \neq P_{ET}O_2[i-1]^T$), or a difference between the measured change in the end-tidal partial pressure of CO₂ ($P_{ET}CO_2[i]^M - P_{ET}CO_2[i-1]^M$) and the targeted change in the end-tidal partial pressure of CO₂ ($P_{ET}CO_2[i]^M - P_{ET}CO_2[i-1]^M$) in breaths where the target end-tidal partial pressure of CO₂ is not equal to the target end-tidal partial pressure of CO₂ from the previous breath ($P_{ET}CO_2[i]^T \neq P_{ET}CO_2[i-1]^T$). Therefore, any sequence that targets the induction of a change in the end-tidal partial pressure of O₂, or a change in the end-tidal partial pressure of CO₂, can be used to tune the estimate of the functional residual capacity.

[0326] The overall metabolic consumption of O₂ (VO₂) can be tuned by observing the difference between the target end-tidal partial pressure of O₂ ($P_{ET}O_2[i]^T$) and the measured end-tidal partial pressure of O₂ ($P_{ET}O_2[i]^M$) in breaths at the end of a long (20 breath) period of constant target end-tidal partial pressures of O₂ ($P_{ET}O_2[i]^T=P_{ET}O_2[i-1]^T$). It is assumed that the measured end-tidal partial pressures of O₂ will have stabilized (less than ± 5 mmHg change in the measured end-tidal partial pressure of O₂ over 3 consecutive breaths), although not necessarily at the target

end-tidal partial pressures of O₂, after 20 breaths of targeting the same end-tidal partial pressures of O₂. If, however, the measured end-tidal partial pressure of O₂ has not stabilized after 20 breaths of targeting the same end-tidal partial pressures of O₂, a longer duration of targeting the same end-tidal partial pressure of O₂ should be used for tuning the overall metabolic consumption of O₂. Therefore, any sequence that targets to maintain the end-tidal partial pressure of O₂ constant for a sufficiently long duration may be used to tune the estimate of the overall metabolic consumption of O₂.

[0327] The overall metabolic production of CO₂ (VCO₂) can be tuned by observing the difference between the target end-tidal partial pressure of CO₂ ($P_{ET}CO_2[i]^T$) and the measured end-tidal partial pressure of CO₂ ($P_{ET}CO_2[i]^M$) in breaths at the end of a long (20 breath) period of constant target end-tidal partial pressures of CO₂ ($P_{ET}CO_2[i]^T=P_{ET}CO_2[i-1]^T$). It is assumed that the measured end-tidal partial pressures of CO₂ will have stabilized (less than ± 2 mmHg change in the measured end-tidal partial pressure of CO₂ over 3 consecutive breaths), although not necessarily at the target end-tidal partial pressure of CO₂, after 20 breaths of targeting the same end-tidal partial pressures of CO₂. If, however, the measured end-tidal partial pressure of CO₂ has not stabilized after 20 breaths of targeting the same end-tidal partial pressures of CO₂, a longer duration of targeting the same end-tidal partial pressure of CO₂ should be used for tuning the overall metabolic production of CO₂. Therefore, any sequence that targets to maintain the end-tidal partial pressure of CO₂ constant for a sufficiently long duration may be used to tune the estimate of the overall metabolic production of CO₂.

[0328] It is not required that all parameter estimates are tuned in the same sequence. Tuning of all parameters in the example sequence is done only for convenience. Different tuning sequences may be used to tune the estimates of different individual, or groups of, parameters.

[0329] Embodiments of mass balance equations:

No SGD:

$$F_I X[i] = \frac{P_{ET} X[i]^T \cdot (FRC + V_T) - P_{ET} X[i-1]^T \cdot (FRC + V_D) - PB \cdot Q \cdot (1-s) \cdot T_B \cdot (C_{MV} X[i] - C_p X[i])}{(V_T - V_D) \cdot PB}$$

SGD:

$$F_I X[i] = \frac{(P_{ET} X[i]^T - P_{ET} X[i-1]^T) \cdot (FRC + V_T) + P_{ET} X[i-1]^T \cdot (FG_1 \cdot T_B) - PB \cdot Q \cdot (1-s) \cdot T_B \cdot (C_{MV} X[i] - C_p X[i])}{FG_1 \cdot T_B \cdot PB}$$

Example 1

[0330] An apparatus according to the invention was used to target end tidal gas concentrations of CO₂ and O₂ in 35 subjects. We targeted the following sequence (values attained in brackets): normocapnia (60 seconds at PetCO₂=40 mm Hg, SD=1 mm; PetO₂=100 mm Hg, SD=2 mm), Hypercapnia (60 seconds at PetCO₂=50 mm Hg, SD=1 mm; PetO₂=100 mm Hg, SD=2 mm), normocapnia (100 seconds), hypercapnia (180 seconds), and normocapnia (110 seconds). FIG. 8, comprises a partial raw data set for 6 subjects.

[0331] The content of all of the patent and scientific references herein is hereby incorporated by reference.

REFERENCES

- [0332] 1. Robbins P A, Swanson G D, Howson M G. A prediction-correction scheme for forcing alveolar gases along certain time courses. *J Appl Physiol* 1982 May; 52(5):1353-1357. [cited 2011 Oct. 11]
- [0333] 2. Slessarev M, Han J, Mardimae A, Prisman E, Preiss D, Volgyesi G, Ansel C, Duffin J, Fisher J A. Prospective targeting and control of end-tidal CO₂ and O₂ concentrations. *J. Physiol. (Lond.)* 2007 June; 581(Pt 3):1207-1219. [cited 2011 Oct. 6]
- [0334] 3. Banzett R B, Garcia R T, Moosavi S H. Simple contrivance "clamps" end-tidal and despite rapid changes in ventilation. *Journal of Applied Physiology* 2000 May; 88(5): 1597-1600. [cited 2011 Oct. 7]
- [0335] 4. Fisher J. Breathing circuits to facilitate the measurement of cardiac output during . . . [Internet]. [date unknown]; [cited 2011 Oct. 11] Available from: <http://www.google.com/patents/about?id=RSqbAAAABAJ>
- [0336] 5. Fisher J. Method of measuring cardiac related parameters non-invasively via the lung . . . [Internet]. [date unknown]; [cited 2011 Oct. 11] Available from: <http://www.google.com/patents/about?id=QiqbAAAABAJ>
- [0337] 6. Fisher J A. Method And Apparatus For Inducing And Controlling Hypoxia [Internet]. [date unknown]; [cited 2011 Oct. 11] Available from: <http://www.google.com/patents/about?id=Cd7HAAAAEBAJ>
- [0338] 7. Slessarev M. Method and Apparatus to Attain and Maintain Target End Tidal Gas Concentrations [Internet]. [date unknown]; [cited 2011 Oct. 11] Available from: <http://www.google.com/patents/about?id=23XGAAAABAJ>
- [0339] 8. Stenzler A. High FIO₂ oxygen mask with a sequential dilution feature [Internet]. [date unknown]; [cited 2011 Oct. 11] Available from: <http://www.google.com/patents/about?id=v1WIAAAAABAJ>
- [0340] 9. Bray J, Cragg P A, Macknight A, Mills R, Taylor D. *Lecture Notes on Human Physiology*. 4th ed. Wiley-Blackwell; 1999.
- [0341] 10. Kratz A, Lewandrowski K B. Case records of the Massachusetts General Hospital. Weekly clinicopathological exercises. Normal reference laboratory values. *N. Engl. J. Med.* 1998 October; 339(15):1063-1072. [cited 2011 Oct. 6]
- [0342] 11. Sund-Levander M, Forsberg C, Wahren L K. Normal oral, rectal, tympanic and axillary body temperature in adult men and women: a systematic literature review. *Scand J Caring Sci* 2002 June; 16(2):122-128. [cited 2011 Oct. 6]
- [0343] 12. Mackowiak P A, Wasserman S S, Levine M M. A critical appraisal of 98.6 degrees F., the upper limit of the normal body temperature, and other legacies of Carl Reinhold August Wunderlich. *JAMA* 1992 September; 268(12):1578-1580. [cited 2011 Oct. 6]
- [0344] 13. Beutler E, Waalen J. The definition of anemia: what is the lower limit of normal of the blood hemoglobin concentration? *Blood* 2006 March; 107(5):1747-1750. [cited 2011 Oct. 6]
- [0345] 14. Peyton P J, Poustie S J, Robinson G J B, Penny D J, Thompson B. Non-invasive measurement of intrapulmonary shunt during inert gas rebreathing. *Physiol Meas* 2005 June; 26(3):309-316. [cited 2011 Oct. 6]
- [0346] 15. Peyton P J, Robinson G J B, McCall P R, Thompson B. Noninvasive measurement of intrapulmonary shunting. *J. Cardiothorac. Vasc. Anesth.* 2004 February; 18(1):47-52. [cited 2011 Oct. 6]
- [0347] 16. Hope D A, Jenkins B J, Willis N, Maddock H, Mapleson W W. Non-invasive estimation of venous admixture: validation of a new formula. *Br J Anaesth* 1995 May; 74(5):538-543. [cited 2011 Oct. 6]
- [0348] 17. Smith H L, Jones J G. Non-invasive assessment of shunt and ventilation/perfusion ratio in neonates with pulmonary failure. *Arch. Dis. Child. Fetal Neonatal Ed.* 2001 September; 85(2): F127-132. [cited 2011 Oct. 6]
- [0349] 18. Finley T N, Lenfant C, Haab P, Piiper J, Rahn H. Venous admixture in the pulmonary circulation of anesthetized dogs. *J Appl Physiol* 1960 May; 15:418-424. [cited 2011 Oct. 6]
- [0350] 19. Krowka M J, Cortese D A. Hepatopulmonary syndrome: an evolving perspective in the era of liver transplantation. *Hepatology* 1990 January; 11(1):138-142. [cited 2011 Oct. 6]
- [0351] 20. Reuter D A, Goetz A E. Measurement of cardiac output. *Anesthetist* 2005 November; 54(11):1135-1151; quiz 1152-1153. [cited 2011 Oct. 6]
- [0352] 21. Ehlers K C, Mylrea K C, Waterson C K, Calkins J M. Cardiac output measurements. A review of current techniques and research. *Ann Biomed Eng* 1986; 14(3):219-239. [cited 2011 Oct. 6]
- [0353] 22. Geerts B F, Aarts L P, Jansen J R. Methods in pharmacology: measurement of cardiac output. *Br J Clin Pharmacol* 2011 March; 71(3):316-330. [cited 2011 Oct. 6]
- [0354] 23. Pugsley J, Lerner A B. Cardiac output monitoring: is there a gold standard and how do the newer technologies compare? *Semin Cardiothorac Vasc Anesth* 2010 December; 14(4):274-282. [cited 2011 Oct. 6]
- [0355] 24. Jegier W, Sekelj P, Auld P A, Simpson R, McGregor M. The relation between cardiac output and body size. *Br Heart J* 1963 July; 25:425-430. [cited 2011 Oct. 6]
- [0356] 25. Ross D N. Theophylline-ethylenediamine in the measurement of blood circulation time. *Br Heart J* 1951 January; 13(1):56-60. [cited 2011 Oct. 6]
- [0357] 26. Zubieta-Calleja G R, Zubieta-Castillo G, Paulav P-E, Zubieta-Calleja L. Non-invasive measurement of circulation time using pulse oximetry during breath holding in chronic hypoxia. *J. Physiol. Pharmacol.* 2005 September; 56 Suppl 4:251-256. [cited 2011 Oct. 6]
- [0358] 27. Sowton E, Bloomfield D, Jones N L, Higgs B E, Campbell E J. Recirculation time during exercise. *Cardiovasc. Res.* 1968 October; 2(4):341-345. [cited 2011 Oct. 6]
- [0359] 28. Chapman C B, Fraser R S. Studies on the effect of exercise on cardiovascular function. I. Cardiac output and mean circulation time. *Circulation* 1954 January; 9(1):57-62. [cited 2011 Oct. 6]
- [0360] 29. Mifflin M D, St Jeor S T, Hill L A, Scott B J, Daugherty S A, Koh Y O. A new predictive equation for resting energy expenditure in healthy individuals. *Am. J. Clin. Nutr.* 1990 February; 51(2):241-247. [cited 2011 Oct. 6]

- [0361] 30. Lenfant C. Time-dependent variations of pulmonary gas exchange in normal man at rest. *J Appl Physiol* 1967 April; 22(4):675-684. [cited 2011 Oct. 6]
- [0362] 31. Wanger J, Clausen J L, Coates A, Pedersen O F, Brusasco V, Burgos F, Casaburi R, Crapo R, Enright P, van der Grinten C P M, Gustafsson P, Hankinson J, Jensen R, Johnson D, Macintyre N, McKay R, Miller M R, Navajas D, Pellegrino R, Viegi G. Standardisation of the measurement of lung volumes. *Eur. Respir. J.* 2005 September; 26(3):511-522. [cited 2011 Oct. 6]
- [0363] 32. Stocks J, Quanjer P H. Reference values for residual volume, functional residual capacity and total lung capacity. *ATS Workshop on Lung Volume Measurements. Official Statement of The European Respiratory Society.* *Eur. Respir. J.* 1995 March; 8(3):492-506. [cited 2011 Oct. 6]
- [0364] 33. Arnold J H, Thompson J E, Arnold L W. Single breath CO₂ analysis: description and validation of a method. *Crit. Care Med.* 1996 January; 24(1):96-102. [cited 2011 Oct. 6]
- [0365] 34. Heller H, Könen-Bergmann M, Schuster K D. An algebraic solution to dead space determination according to Fowler's graphical method. *Comput. Biomed. Res.* 1999 April; 32(2):161-167. [cited 2011 Oct. 6]
- [0366] 35. Williams E M, Hamilton R M, Sutton L, Viale J P, Hahn C E. Alveolar and dead space volume measured by oscillations of inspired oxygen in awake adults. *Am. J. Respir. Crit. Care Med.* 1997 December; 156(6):1834-1839. [cited 2011 Oct. 6]
- [0367] 36. Hart M C, Orzalesi M M, Cook C D. Relation between anatomic respiratory dead space and body size and lung volume. *Journal of Applied Physiology* 1963 May; 18(3):519-522. [cited 2011 Oct. 6]
- [0368] 37. Ito S, Mardimae A, Han J, Duffin J, Wells G, Fedorko L, Minkovich L, Katznelson R, Meineri M, Arenovich T, Kessler C, Fisher J A. Non-invasive prospective targeting of arterial PCO₂ in subjects at rest. *J. Physiol. (Lond.)* 2008 August; 586(Pt 15):3675-3682. [cited 2011 Oct. 6]
- [0369] 38. Somogyi R B, Vesely A E, Preiss D, Prisman E, Volgyesi G, Azami T, Iscoe S, Fisher J A, Sasano H. Precise control of end-tidal carbon dioxide levels using sequential rebreathing circuits. *Anaesth Intensive Care* 2005 December; 33(6):726-732. [cited 2011 Oct. 6]
- [0370] 39. Fierstra J, Machina M, Battisti-Charbonney A, Duffin J, Fisher J A, Minkovich L. End-inspiratory rebreathing reduces the end-tidal to arterial PCO₂ gradient in mechanically ventilated pigs. *Intensive Care Med* 2011 September; 37(9):1543-1550. [cited 2011 Oct. 6]
- [0371] 40. Jones N L, Robertson D G, Kane J W, Campbell E J. Effect of PCO₂ level on alveolar-arterial PCO₂ difference during rebreathing. *J Appl Physiol* 1972 June; 32(6):782-787. [cited 2011 Oct. 6]
- [0372] 41. Raine J M, Bishop J M. A-a difference in O₂ tension and physiological dead space in normal man. *J Appl Physiol* 1963 March; 18:284-288. [cited 2011 Oct. 6]
- [0373] 42. Kelman G R. Digital computer subroutine for the conversion of oxygen tension into saturation. *J Appl Physiol* 1966 July; 21(4):1375-1376. [cited 2011 Oct. 6]
- [0374] 43. Wheeler D S, Wong H R, Shanley T P. *Pediatric Critical Care Medicine: Basic Science and Clinical Evidence.* 1st ed. Springer; 2007.
- [0375] 44. Burnett R W, Noonan D C. Calculations and correction factors used in determination of blood pH and blood gases. *Clin. Chem.* 1974 December; 20(12):1499-1506. [cited 2011 Oct. 6]
- [0376] 45. Loeppky J A, Luft U C, Fletcher E R. Quantitative description of whole blood CO₂ dissociation curve and Haldane effect. *Respir Physiol* 1983 February; 51(2):167-181. [cited 2011 Oct. 6]
- [0377] 46. Douglas A R, Jones N L, Reed J W. Calculation of whole blood CO₂ content. *J. Appl. Physiol.* 1988 July; 65(1):473-477. [cited 2011 Oct. 6]
- [0378] 47. Kelman G R. Digital computer procedure for the conversion of PCO₂ into blood CO₂ content. *Respir Physiol* 1967 August; 3(1):111-115. [cited 2011 Oct. 6]
- [0379] 48. Olszowka A J, Farhi L E. A system of digital computer subroutines for blood gas calculations. *Respir Physiol* 1968 March; 4(2):270-280. [cited 2011 Oct. 6]
- [0380] 49. Cherniack N S, Longobardo G S. Oxygen and carbon dioxide gas stores of the body. *Physiol. Rev.* 1970 April; 50(2):196-243. [cited 2011 Oct. 6]
- [0381] 50. Cherniack N S, Longobardo G S, Palermo F P, Heymann M. Dynamics of oxygen stores changes following an alteration in ventilation. *J Appl Physiol* 1968 June; 24(6):809-816. [cited 2011 Oct. 6]
- [0382] 51. Farhi L E, Rahn H. Dynamics of changes in carbon dioxide stores. *Anesthesiology* 1960 December; 21:604-614. [cited 2011 Oct. 6]
- [0383] 52. Cherniack N S, Longobardo G S, Staw I, Heymann M. Dynamics of carbon dioxide stores changes following an alteration in ventilation. *J Appl Physiol* 1966 May; 21(3):785-793. [cited 2011 Oct. 6]
1. A method of controlling a gas delivery device to target or attain a target end tidal partial pressure of gas X in a subject, wherein a signal processor operatively associated with a gas delivery device controls the amount of gas X contained in a volume of inspiratory gas delivered to a subject in a respective breath [i], using inputs and outputs processed by the signal processor for a respective breath [i], the method comprising:
- Obtaining input of one or more values sufficient to compute the concentration of gas X in the mixed venous blood entering the subject's pulmonary circulation for gas exchange in one or more respective breaths [i] ($C_{MV-X}[i]$);
 - Obtaining input of a logarithmically attainable end tidal partial pressure of gas X ($P_{etX}[i]^T$) for a respective breath [i];
 - Utilizing a prospective computation to determine an amount of gas X required to be inspired by the subject to target the $P_{etX}[i]^T$ for a respective breath [i], the prospective computation using inputs sufficient to compute a mass balance equation for a respective breath [i], the inputs including values, for a respective breath [i], from which $C_{MV-X}[i]$ and the concentration of gas X in the subject's lung affecting mass transfer can be determined, wherein one or more values required to control the amount of gas X in a volume of gas delivered to the subject is output from the mass balance equation; and
 - Outputting control signals to the gas delivery device to control the amount gas X in a volume of gas delivered to the subject in a respective breath [i] to target the respective $P_{etX}[i]^T$ based on the prospective computation.

2. A method according to claim 1, wherein the mass balance equation is formulated in terms of discrete respective breaths [i] taking into account one or more discrete volumes corresponding to a subject's FRC, anatomic dead space, a volume of gas transferred between the subject's lung and pulmonary circulation in the respective breath [i] and an individual tidal volume of the respective breath [i].

3. A method according to claim 1, wherein the inspired gas comprises a first inspired gas and a second inspired gas, wherein the first inspired gas is delivered in the first part of a respective breath [i] followed by the second inspired gas for the remainder of the respective breath [i], the volume of the first inspired gas preferably selected so that intake of the second inspired gas at least fills the entirety of the anatomic dead space.

4. A method according to claim 1, wherein a concentration of gas X (F_{iX}) in the first inspired gas is computed from the mass balance equation to target or attain a $PetX[i]^T$ in a respective breath [i].

5. A method according to claim 1, wherein the mass balance equation is solved for F_{iX} .

6. A method according to claim 1, comprising the step of obtaining inputs required to compute F_{iX} prospectively to target $PetX[i]^T$ for a respective breath [i], wherein F_{iX} is computed using a mass balance equation which comprises terms corresponding to all or an application-specific subset of the terms in:

$$F_{iX}[i] = \frac{(P_{ETX}[i]^T - P_{ETX}[i-1]^T) \cdot (FRC + V_T) + P_{ETX}[i-1]^T \cdot (FG_1 \cdot T_B) - PB \cdot Q \cdot (1-s) \cdot T_B \cdot (C_{MVX}[i] - C_pX[i])}{FG_1 \cdot T_B \cdot PB} \quad \text{eq. 1}$$

or

$$F_{iX}[i] = \frac{P_{ETX}[i]^T \cdot (FRC + V_T) - P_{ETX}[i-1]^T \cdot (FRC + V_D) - PB \cdot Q \cdot (1-s) \cdot T_B \cdot (C_{MVX}[i] - C_pX[i])}{(V_T - V_D) \cdot PB} \quad \text{eq. 2}$$

7. A method according to claim 6, wherein F_{iX} is computed prospectively from a mass balance equation expressed in terms which correspond to all or an application-specific subset of the terms in equation 1 and the first inspired gas has a concentration of gas X which corresponds to F_{iX} for the respective breath [i].

8. A method according to claim 1, wherein the gas inspired by the subject in each respective breath [i] comprises a first inspired gas and a second inspired neutral gas, wherein the first inspired gas is delivered in the first part of a respective breath [i] followed by a second inspired neutral gas for the remainder of the respective breath [i], the volume of the first inspired gas selected so that intake of the second inspired neutral gas at least fills the entirety of the anatomic dead space; wherein F_{iX} is computed prospectively using a mass balance equation which comprises all or a functional subset of the terms in equation 1 and wherein the first inspired gas has a concentration of gas X which corresponds to F_{iX} for the respective breath [i].

9. A method according to claim 1, comprising ascertaining the volume of inspired gas entering the subject's alveoli by fixing a tidal volume of an inspired gas containing gas X using a ventilator and subtracting a volume of gas corresponding to an estimated or measured value for the subject's anatomic dead space volume.

10. A method according to claim 1, wherein the gas inspired by the subject is inspired via a sequential gas delivery circuit; and wherein the rate of flow of gas into the sequential gas delivery circuit is used to compute the volume of inspired gas entering the subject's alveoli in a respective breath [i].

11. A method according to claim 1, further comprising tuning one or more parameters required for computation of F_{iX} including at least one parameter selected from the group consisting of the subject's functional residual capacity (FRC) and the subject's total metabolic production or consumption of gas X.

12. A method according to claim 11, wherein FRC is tuned in a series of tuning breaths by:

- (a) changing the targeted end tidal concentration of gas X between a tuning breath [i+x] and a previous tuning breath [i+x-1];
- (b) comparing the magnitude of the difference between the targeted end tidal concentration of gas X for said tuning breaths [i+x] and [i+x-1] with the magnitude of the difference between the measured end tidal concentration of gas X for the same tuning breaths to quantify any discrepancy in relative magnitude; and
- (c) adjusting the value of FRC in proportion to the discrepancy to reduce the discrepancy in any subsequent prospective computation of F_{iX} .

13. A method according to claim 11, wherein the total metabolic production or consumption of gas X is tuned in a series of tuning breaths by comparing a targeted end tidal concentration of gas X ($PetX[i+x]^T$) for the at least one tuning breath [i+x] with a corresponding measured end tidal concentration of gas X for the corresponding breath [i+x] to quantify any discrepancy and adjusting the value of the total metabolic production or consumption of gas X in proportion to any discrepancy to reduce the discrepancy in any subsequent prospective computation of F_{iX} .

14. A method according to claim 13, wherein FRC is tuned in a series of tuning breaths in which a sequence of end tidal concentrations of gas X is targeted at least once by:

- (a) obtaining input of a measured baseline steady state value for $PetX[i]$ for computing F_{iX} at start of a sequence;
- (b) selecting a target end tidal concentration of gas X ($PetX[i]^T$) for at least one tuning breath [i+x] wherein $PetX[i+x]^T$ differs from $PetX[i+x-1]^T$; and
- (c) comparing the magnitude of the difference between the targeted end tidal concentration of gas X for said tuning breaths [i+x] and [i+x-1] with the magnitude of the difference between the measured end tidal concentration of gas X for the same tuning breaths to quantify any discrepancy in relative magnitude;
- (d) adjusting the value of FRC in proportion to any discrepancy in magnitude to reduce the discrepancy in a subsequent prospective computation of F_{iX} including in any subsequent corresponding tuning breaths [i+x-1] and [i+x] forming part of an iteration of the sequence.

15. A method according to claim 12, wherein the total metabolic consumption or production of gas X is tuned in a series of tuning breaths in which a sequence of end tidal concentrations of gas X is targeted at least once by:

- (a) obtaining input of a measured baseline steady state value for $PetX[i]$ for computing F_{iX} at start of a sequence;

- (b) targeting a selected target end tidal concentration of gas X ($P_{ETX}[i]^T$) for each of a series of tuning breaths $[i+1 \dots i+n]$, wherein $P_{ETX}[i]^T$ differs from the baseline steady state value for $P_{ETX}[i]$;
- (c) comparing the targeted end tidal concentration of gas X ($P_{ETX}[i+x]^T$) for at least one tuning breath $[i+x]$ in which the targeted end tidal gas concentration of gas X has been achieved without drift in a plurality of prior breaths $[1+x-1, 1+x-2 \dots]$ with a corresponding measured end tidal concentration of gas X for a corresponding breath $[i+x]$ to quantify any discrepancy and adjusting the value of the total metabolic consumption or production of gas X in proportion to the discrepancy to reduce the discrepancy in a subsequent prospective computation of $F_I X$ including in any subsequent corresponding tuning breath $[i+x]$ forming part of an iteration of the sequence.

16. A method according to claim 1, wherein input of a concentration of gas X in the mixed venous blood entering the subject's pulmonary circulation for gas exchange in a respective breath $[i]$ ($C_{MV}X[i]$) is determined by a compartmental model of gas dynamics.

17. A method according to claim 14, wherein the compartmental model of gas dynamics accounts for the total and compartmental metabolic production or consumption of gas X, the total and compartmental storage capacity for gas X and the total cardiac output and compartmental contribution to total cardiac output.

18. A method according to claim 1, wherein gas X is carbon dioxide.

19. An apparatus for controlling an amount of at least one gas X in a subject's lung to attain a targeted end tidal partial pressure of the at least one gas X, comprising:

- (1) a gas delivery device;
- (2) a control system for controlling the gas delivery device, the control system configured for:
 - (a) Obtaining input of a concentration of gas X in the mixed venous blood entering the subject's pulmonary circulation for gas exchange in one or more respective breaths $[i]$ ($C_{MV}X[i]$);
 - (b) Obtaining input of a logistically attainable end tidal partial pressure of gas X ($P_{ETX}[i]^T$) for a respective breath $[i]$;
 - (c) Obtaining input of a prospective computation of an amount of gas X required to be inspired by the subject in an inspired gas to target the $P_{ETX}[i]^T$ for a respective breath $[i]$ using inputs required to compute a mass balance equation including $C_{MV}X[i]$, wherein one or more values required to control the amount of gas X in the volume of gas delivered to the subject is output from the mass balance equation; and
 - (d) Controlling the amount of gas X in the volume of gas delivered to the subject in a respective breath $[i]$ to target the respective $P_{ETX}[i]^T$ based on the prospective computation.

20. An apparatus according to claim 19, wherein the mass balance equation is computed based on a tidal model of the lung.

21. An apparatus according to claim 19, wherein the mass balance equation is computed in terms of discrete respective breaths $[i]$ including one or more discrete volumes comprising or corresponding to a subject's FRC, anatomic dead space, a volume of gas transferred between the subject's lung and pulmonary circulation in the respective breath $[i]$ and an individual tidal volume of the respective breath $[i]$.

22. An apparatus according to claim 19, wherein the inspired gas comprises a first inspired gas and a second inspired gas, wherein the first inspired gas is delivered in a first part of a respective breath $[i]$ followed by the second inspired gas for a remainder of the respective breath $[i]$, a volume of the first inspired gas selected so that intake of the second inspired gas at least fills the entirety of the anatomic dead space; and wherein for a respective breath $[i]$, the volume of the first inspired gas and a concentration of gas X in the second inspired gas are selected to attain $P_{ETX}[i]^T$; and wherein for a respective breath $[i]$, the concentration of gas X in the second inspired gas corresponds to $P_{ETX}[i]^T$ for a respective breath $[i]$.

23. An apparatus according to claim 19, comprising the step of obtaining inputs required to compute an $F_I X$ to target $P_{ETX}[i]^T$ for a respective breath $[i]$, wherein $F_I X$ is computed using a mass balance equation which comprises terms corresponding to all or an application-specific subset of the terms in:

$$F_I X[i] = \frac{(P_{ETX}[i]^T - P_{ETX}[i-1]^T) \cdot (FRC + V_T) + P_{ETX}[i-1]^T \cdot (FG_1 \cdot T_B) - PB \cdot Q \cdot (1-s) \cdot T_B \cdot (C_{MV}X[i] - C_p X[i])}{FG_1 \cdot T_B \cdot PB} \quad \text{eq. 1}$$

or

$$F_I X[i] = \frac{P_{ETX}[i]^T \cdot (FRC + V_T) - P_{ETX}[i-1]^T \cdot (FRC + V_D) - PB \cdot Q \cdot (1-s) \cdot T_B \cdot (C_{MV}X[i] - C_p X[i])}{(V_T - V_D) \cdot PB} \quad \text{eq. 2}$$

24. An apparatus according to claim 19, wherein the control system is implemented by a computer.

25. An apparatus according to claim 24, wherein the computer provides output signals to one or more rapid flow controllers.

26. An apparatus according to claim 24, wherein the computer receives input from a gas analyzer and an input device adapted for providing input of one or more logistically attainable target end tidal concentration of gas X ($P_{ETX}[i]^T$) for a series of respective breaths $[i]$.

27. An apparatus according to claim 19, wherein the control system, in each respective breath $[i]$, controls the delivery of at least a first inspired gas and wherein delivery of the first inspired gas is coordinated with delivery a second inspired neutral gas, such that a selected volume of the first inspired gas is delivered in a first part of a respective breath $[i]$ followed by the second inspired neutral gas for a remainder of the respective breath $[i]$.

* * * * *

专利名称(译)	获得和保持气体目标端潮气分压的装置		
公开(公告)号	US20170361042A1	公开(公告)日	2017-12-21
申请号	US15/585999	申请日	2017-05-03
[标]申请(专利权)人(译)	FISHER JOSEPH DUFFIN JAMES SLESSAREV 萨芬 凯斯勒凯西 伊藤正二		
申请(专利权)人(译)	KLEIN , MICHAEL FISHER , JOSEPH DUFFIN , JAMES SLESSAREV , 萨芬 凯斯勒 , CATHIE ITO , SHOJI		
当前申请(专利权)人(译)	KLEIN , MICHAEL FISHER , JOSEPH DUFFIN , JAMES SLESSAREV , 萨芬 凯斯勒 , CATHIE ITO , SHOJI		
[标]发明人	KLEIN MICHAEL FISHER JOSEPH DUFFIN JAMES SLESSAREV MARAT KESSLER CATHIE ITO SHOJI		
发明人	KLEIN, MICHAEL FISHER, JOSEPH DUFFIN, JAMES SLESSAREV, MARAT KESSLER, CATHIE ITO, SHOJI		
IPC分类号	A61M16/00 A61B5/00 A61M16/10 A61B5/083 A61M16/12 A61M16/08		
CPC分类号	A61B5/4836 A61M16/0003 A61M16/0069 A61M16/0883 A61M16/1005 A61M16/122 A61B5/0833 A61B5/0836 A61M16/085 A61M2230/435 A61M2230/432 A61M2230/43 A61M2205/502 A61M2016 /103 A61M2016/1025 A61M2016/102 A61M2016/0027 A61M2016/0021 A61M16/0051 A61B5/083 A61M16/12 A61M16/026		
优先权	14/363259 2014-06-05 US PCT/CA2012/001123 2012-12-05 WO 61/566997 2011-12-05 US		
外部链接	Espacenet USPTO		

摘要(译)

处理器获得对于一个或多个相应呼吸[i]的气体X (PetX [i] T) 的逻辑上可获得的末端潮气分压的输入以及对气体量X的预期计算的输入需要受到吸入气体中的受试者的启发, 以使用需要输入以利用质量平衡关系的相应呼吸[i]来针对PetX [i] T , 其中需要一个或多个值控制输送到受试者的气体体积中的气体X的量从质量平衡关系的表达输出。质量平衡关系以一种形式表示, 该形式考虑 (预

期)各自的呼吸[1],肺泡周围的毛细血管中的气体X的量和肺泡中的气体X的量,任选地基于a肺的模型,其解释了肺中的那些亚体积的气体,其基本上影响影响质量转移的肺泡气体X浓度。

Apparatus

