



(19) **United States**

(12) **Patent Application Publication**
Dalvi et al.

(10) **Pub. No.: US 2016/0367173 A1**
(43) **Pub. Date: Dec. 22, 2016**

(54) **NON-INVASIVE OPTICAL PHYSIOLOGICAL DIFFERENTIAL PATHLENGTH SENSOR**

Publication Classification

(71) Applicant: **Cercacor Laboratories, Inc.**, Irvine, CA (US)

(51) **Int. Cl.**
A61B 5/145 (2006.01)
A61B 5/1455 (2006.01)
A61B 5/00 (2006.01)

(72) Inventors: **Cristiano Dalvi**, Lake Forest, CA (US); **Ferdyan Lesmana**, Irvine, CA (US); **Hung Vo**, Fountain Valley, CA (US); **Jeroen Poeze**, Rancho Santa Margarita, CA (US); **Jesse Chen**, Foothill Ranch, CA (US); **Kevin Pauley**, Lake Forest, CA (US); **Mathew Paul**, Irvine, CA (US); **Sean Merritt**, Lake Forest, CA (US); **Thomas B. Blank**, Laguna Beach, CA (US); **Massi Joe E. Kiani**, Laguna Niguel, CA (US)

(52) **U.S. Cl.**
CPC *A61B 5/145* (2013.01); *A61B 5/14532* (2013.01); *A61B 5/0008* (2013.01); *A61B 5/0002* (2013.01); *A61B 5/6801* (2013.01); *A61B 5/14552* (2013.01)

(21) Appl. No.: **15/160,907**

(57) **ABSTRACT**

(22) Filed: **May 20, 2016**

An optical physiological sensor configured to perform high speed spectral sweep analysis of sample tissue being measured to non-invasively predict an analyte level of a patient. An emitter of the optical physiological sensor can be regulated to operate at different temperatures to emit radiation at different wavelengths. Variation in emitter drive current, duty cycle, and forward voltage can also be used to cause the emitter to emit a range of wavelengths. Informative spectral data can be obtained during the sweeping of specific wavelength regions of sample tissue.

Related U.S. Application Data

(60) Provisional application No. 62/165,618, filed on May 22, 2015.

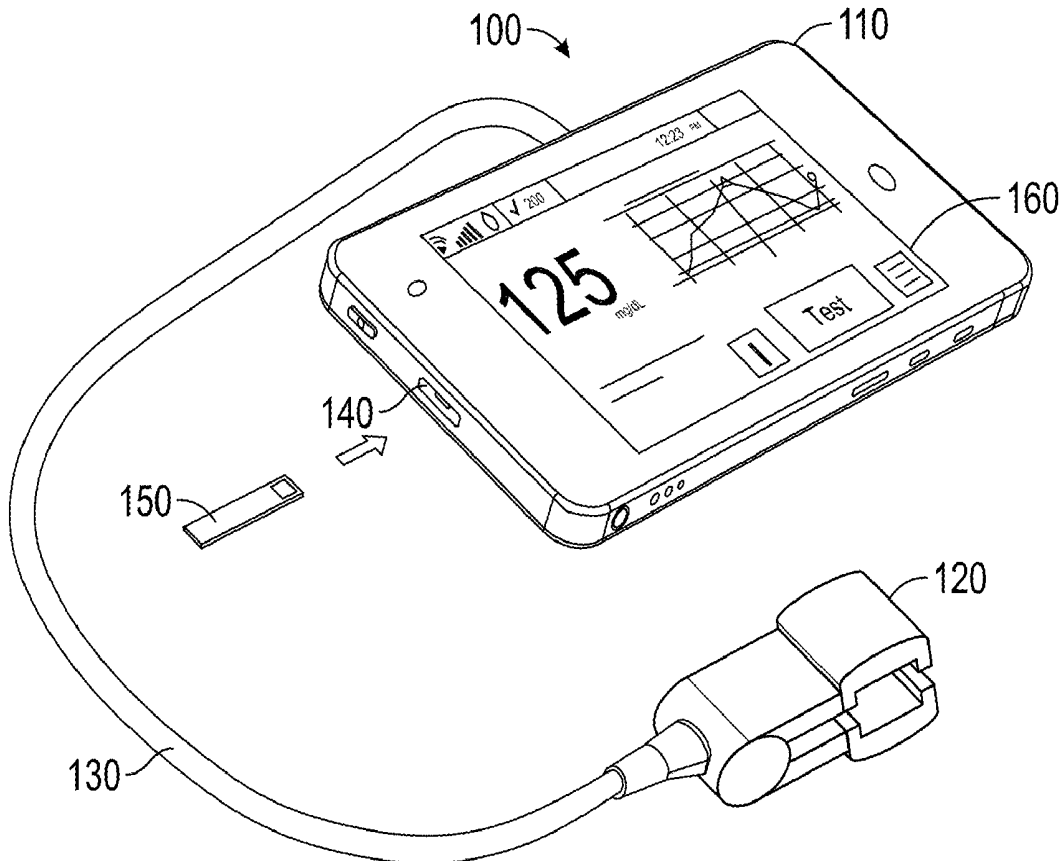

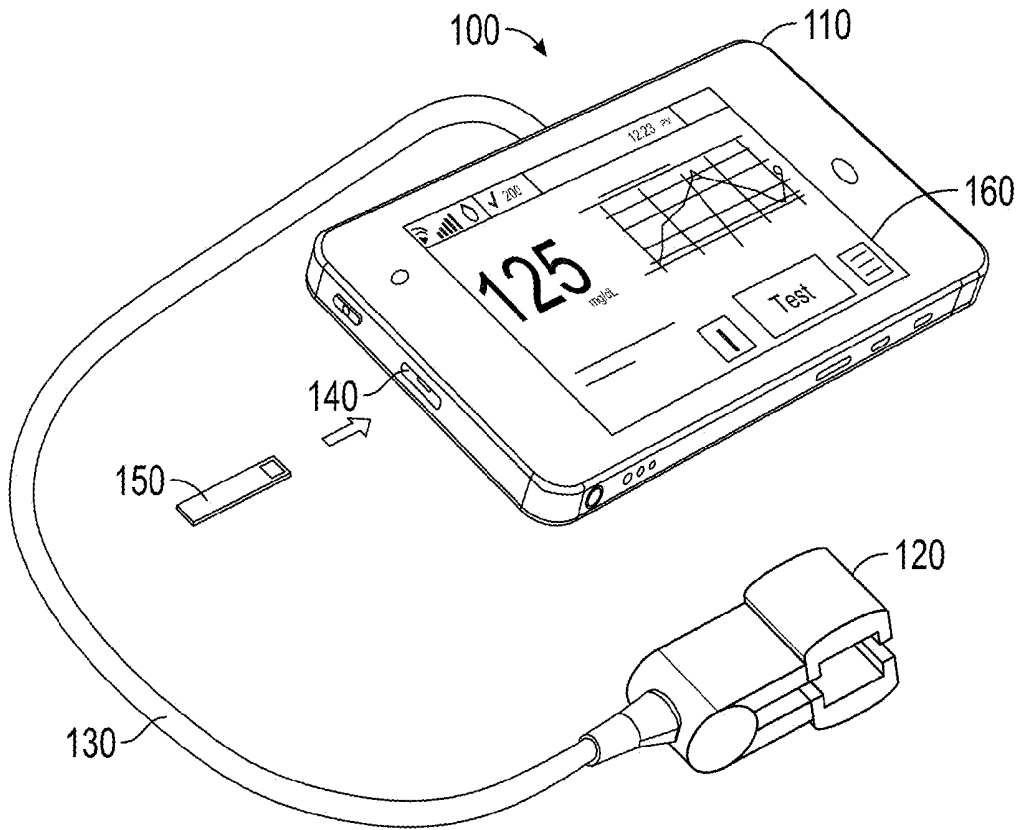

FIG. 1

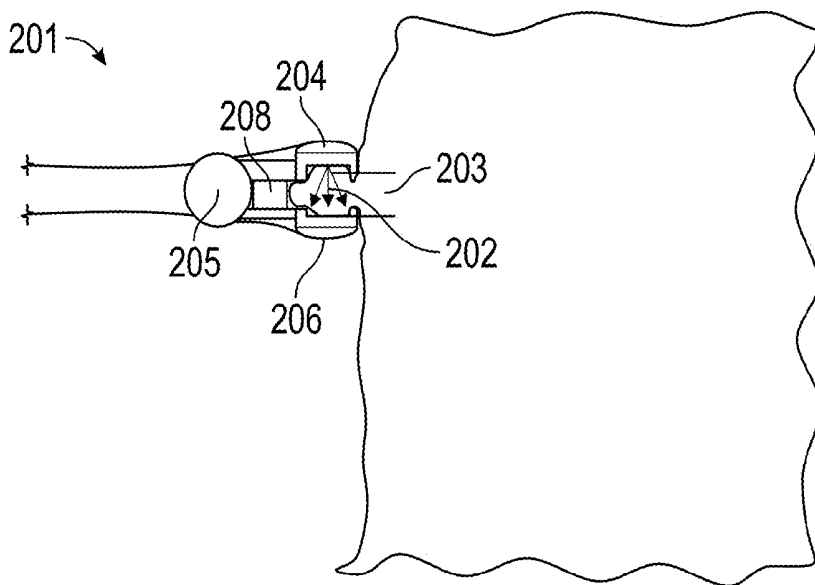

FIG. 2

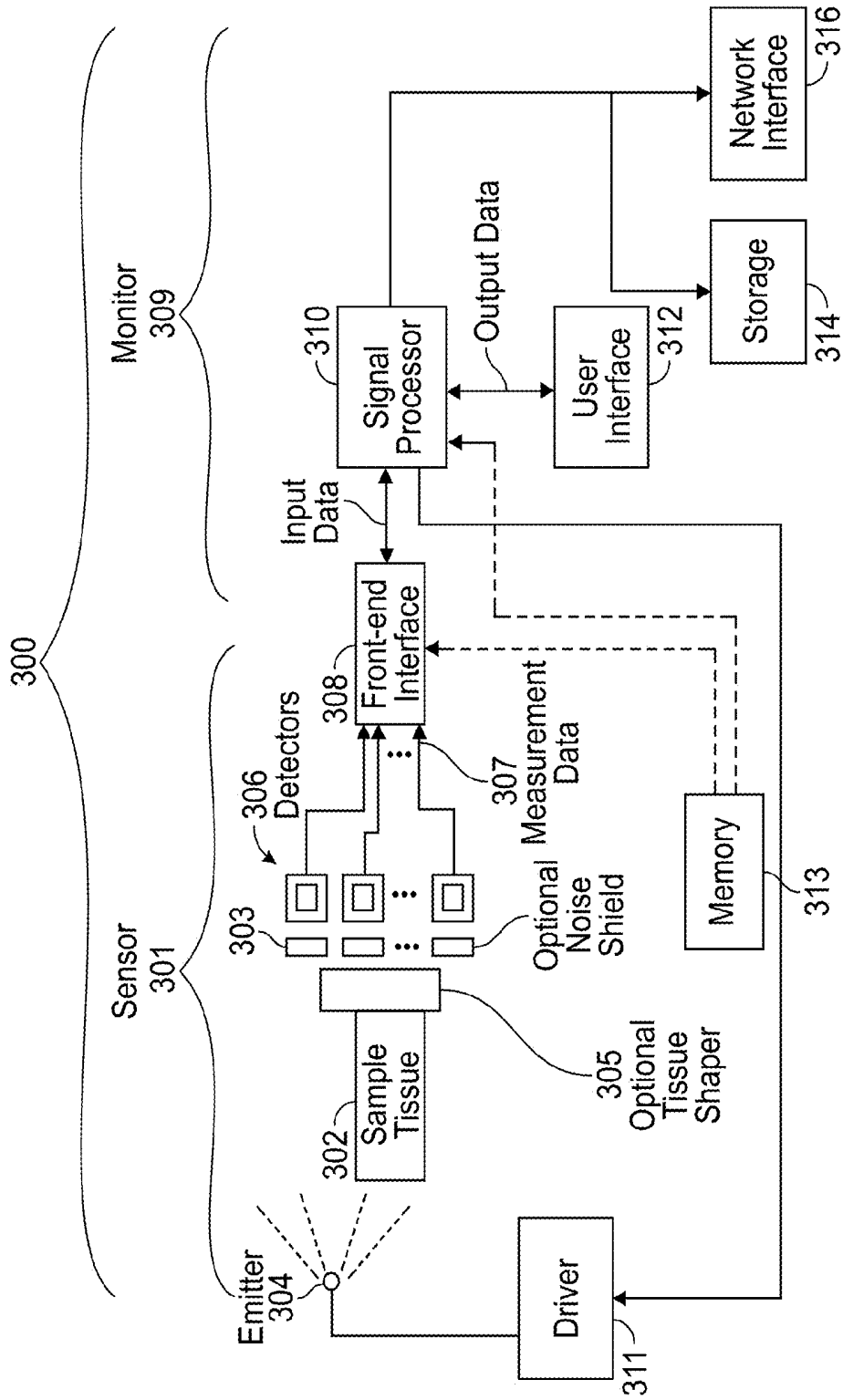

FIG. 3

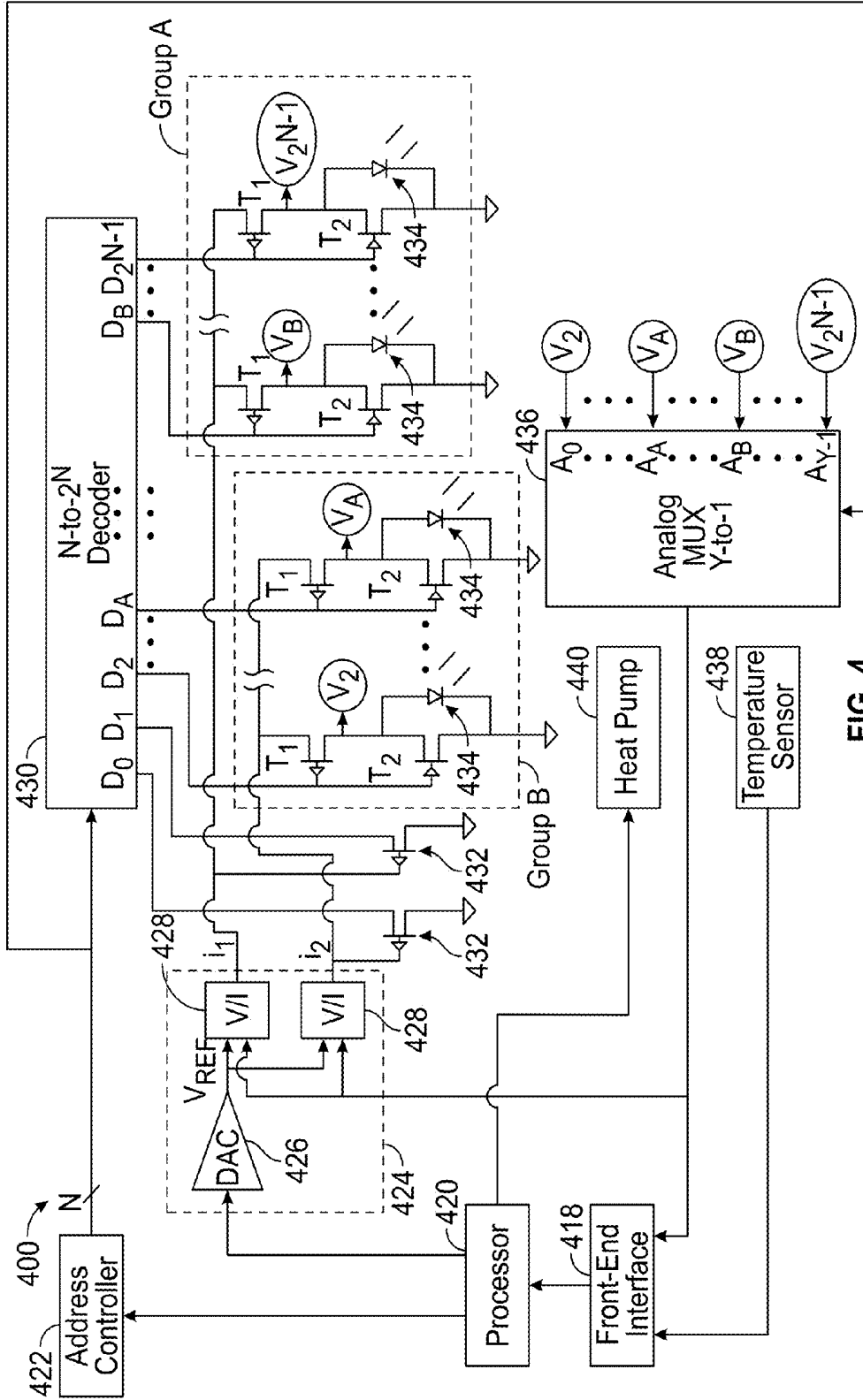

FIG. 4

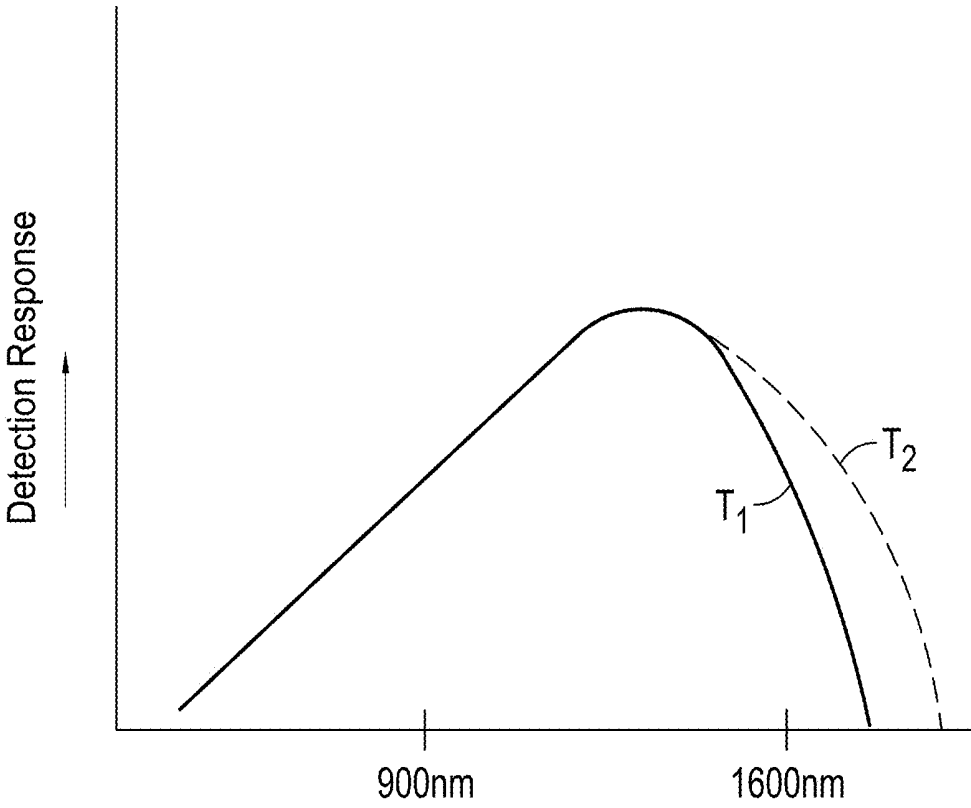

FIG. 5

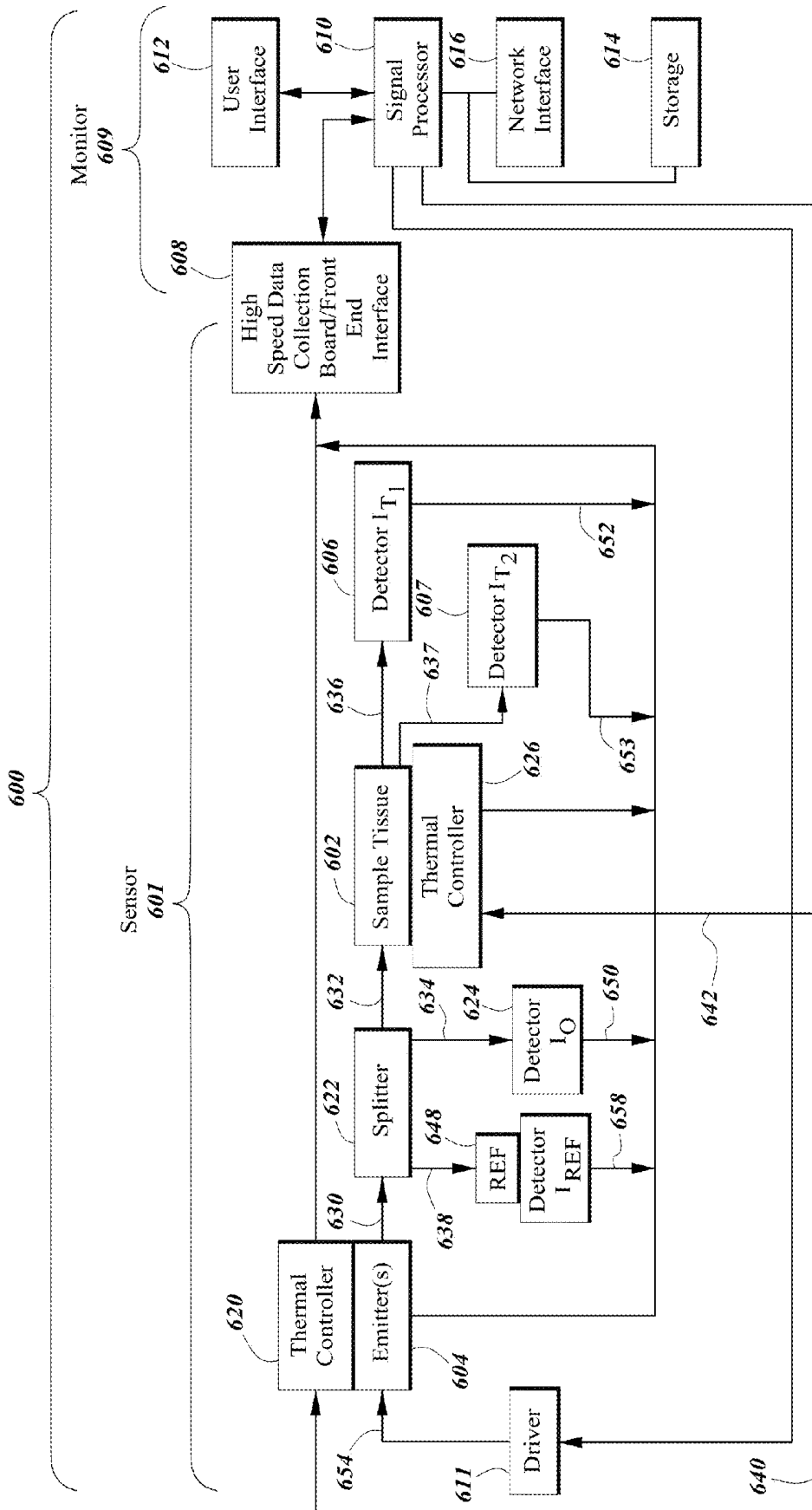
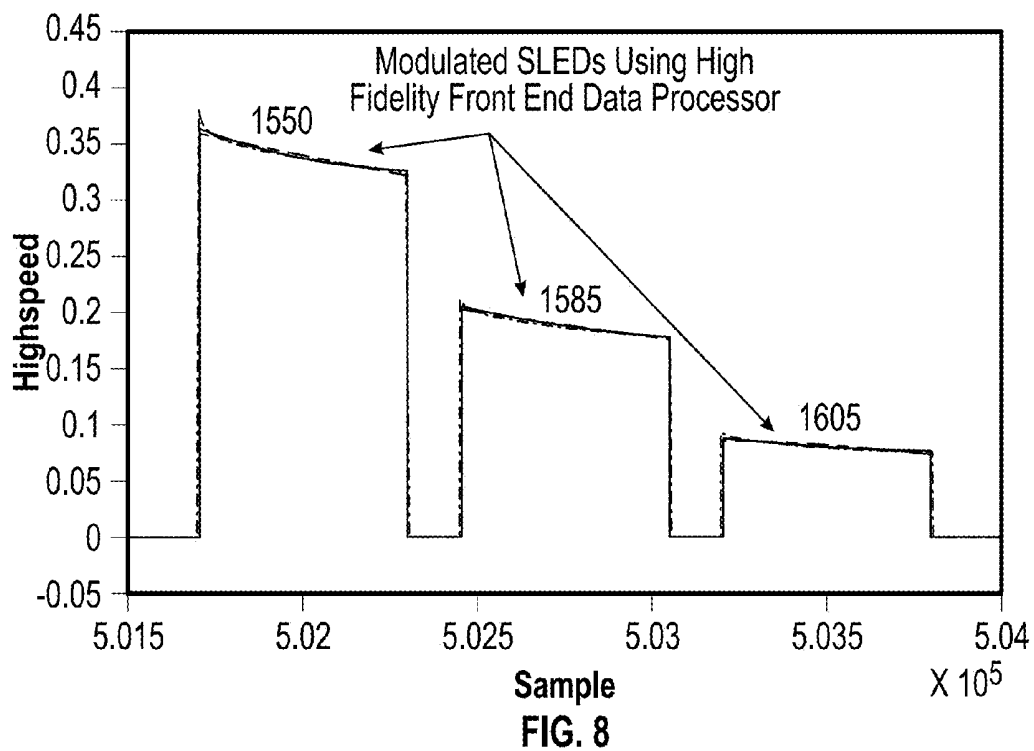
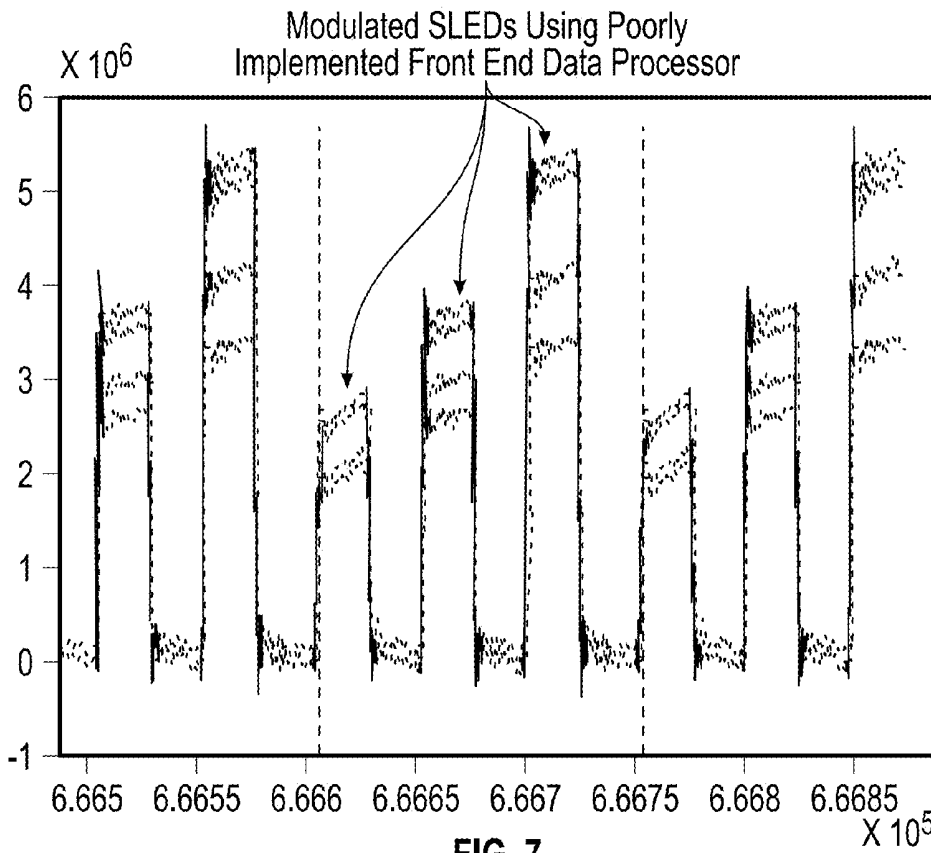

FIG. 6



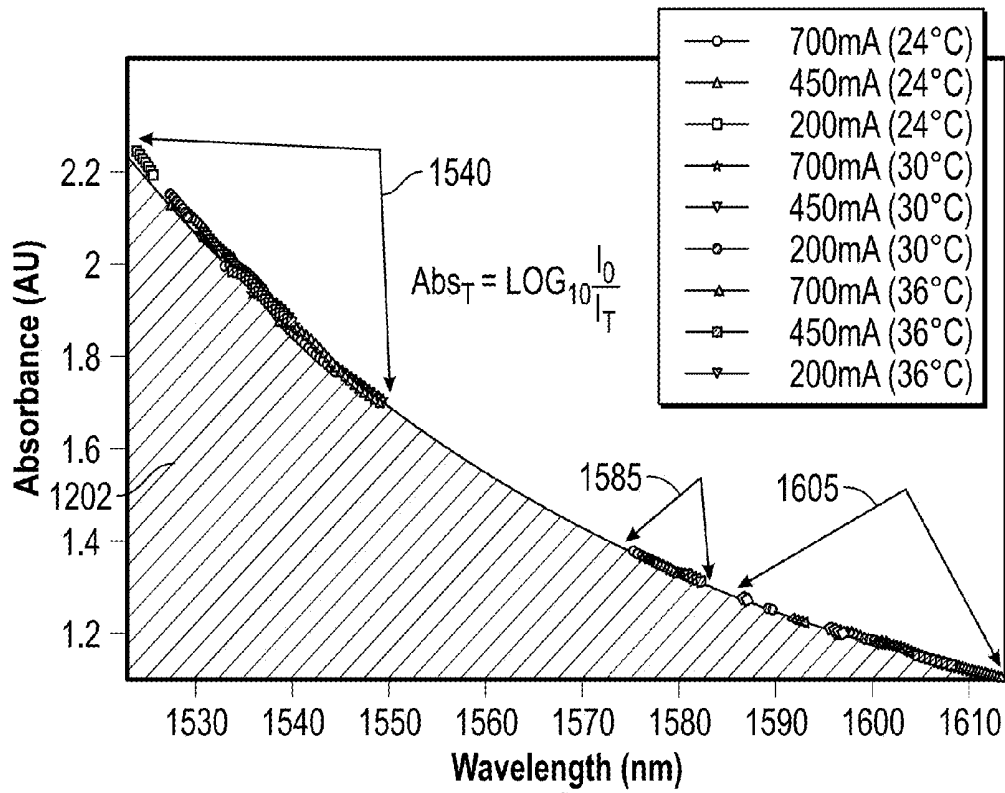

FIG. 9

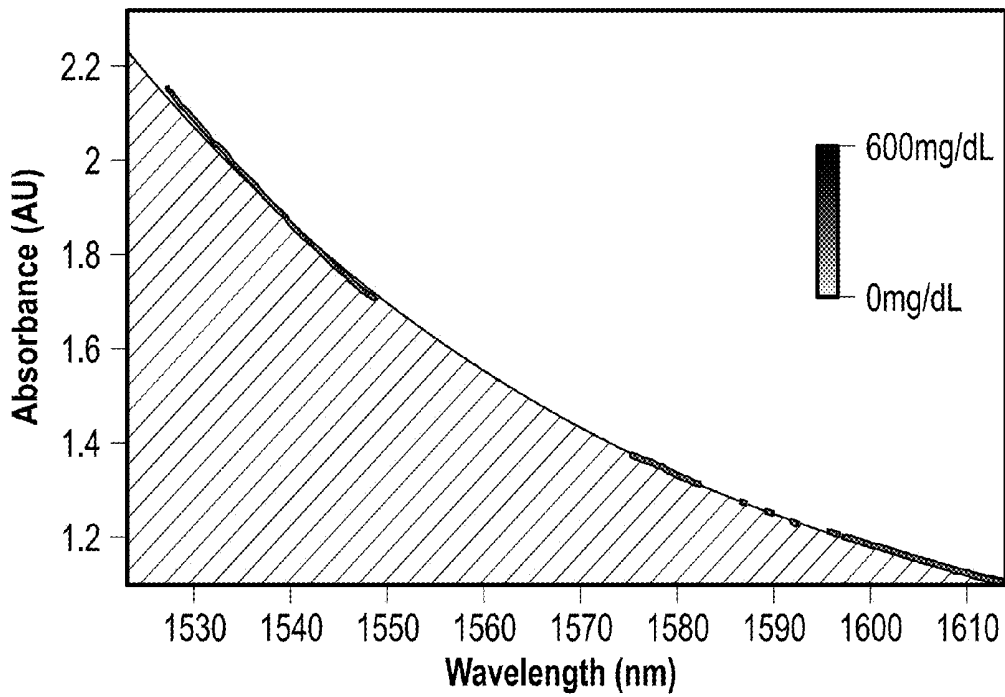

FIG. 10A

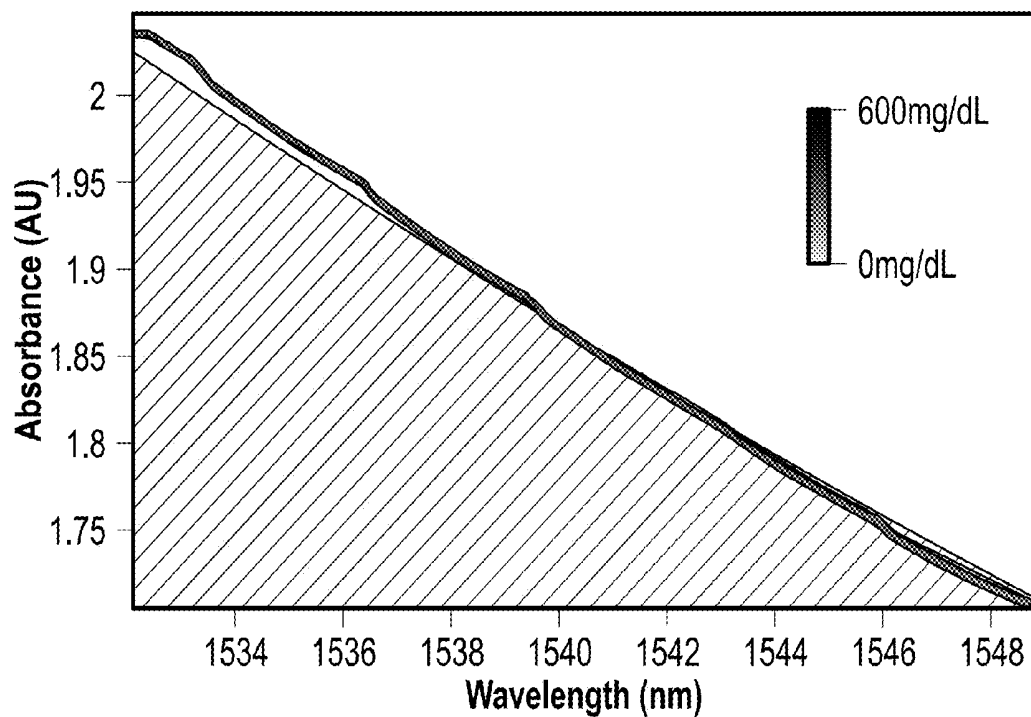

FIG. 10B

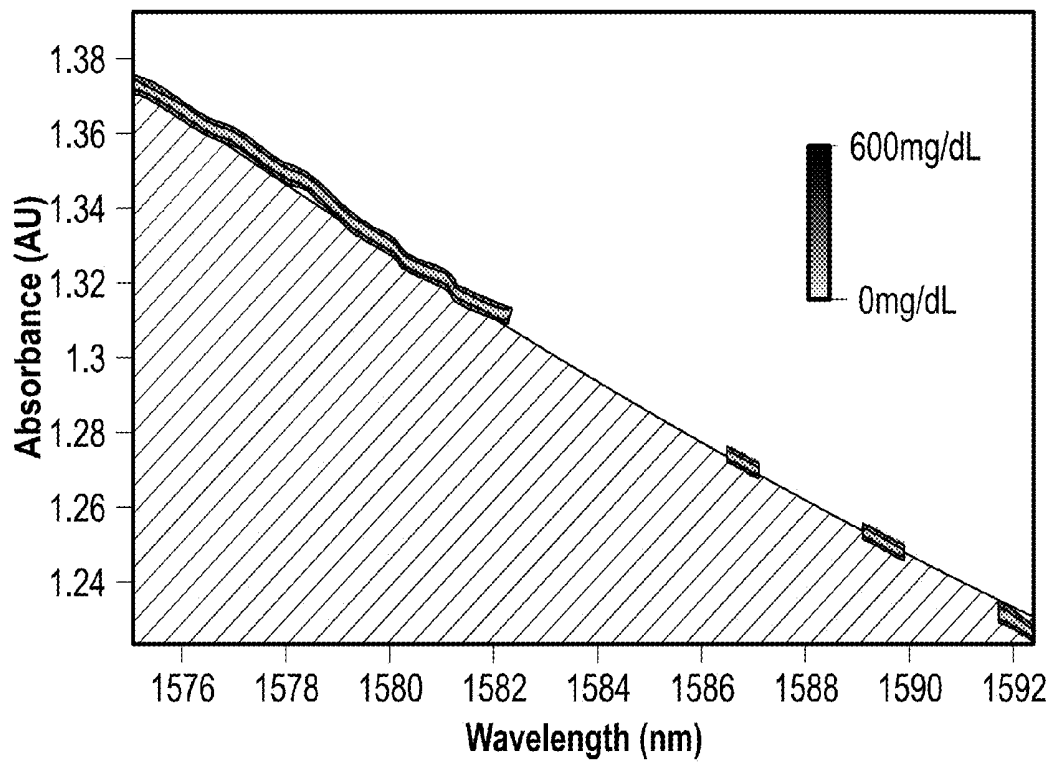

FIG. 10C

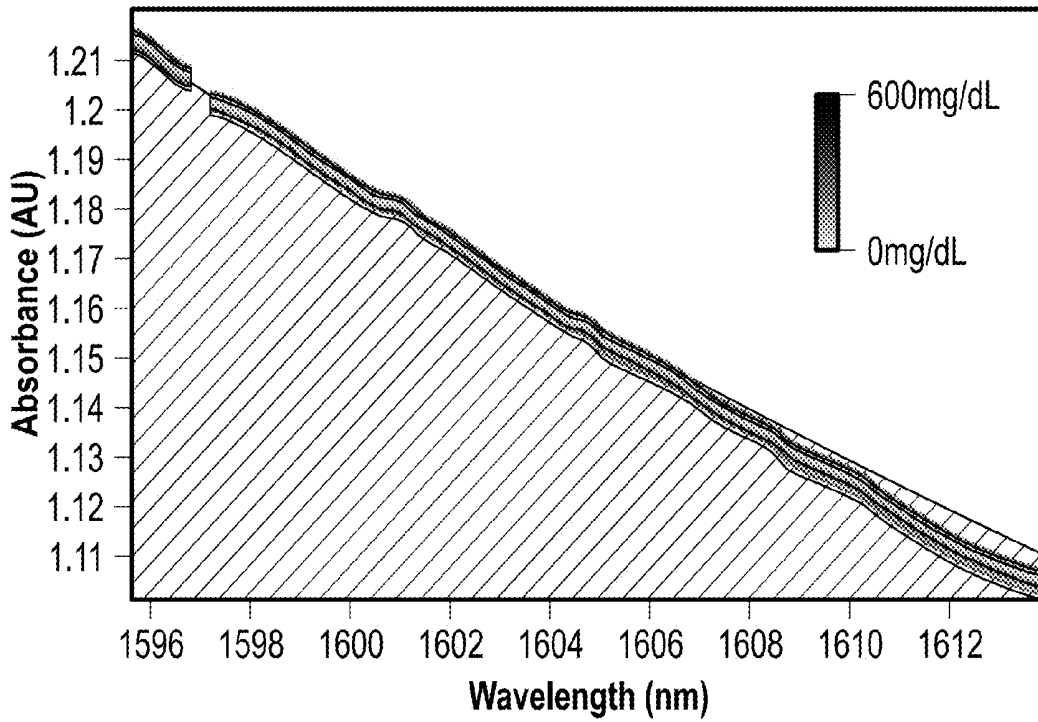

FIG. 10D

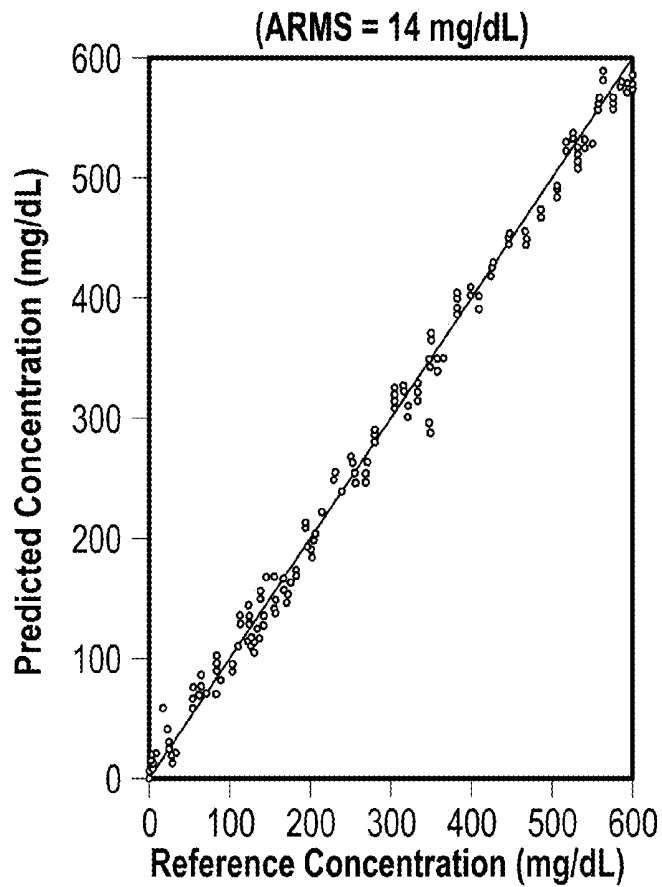

FIG. 11

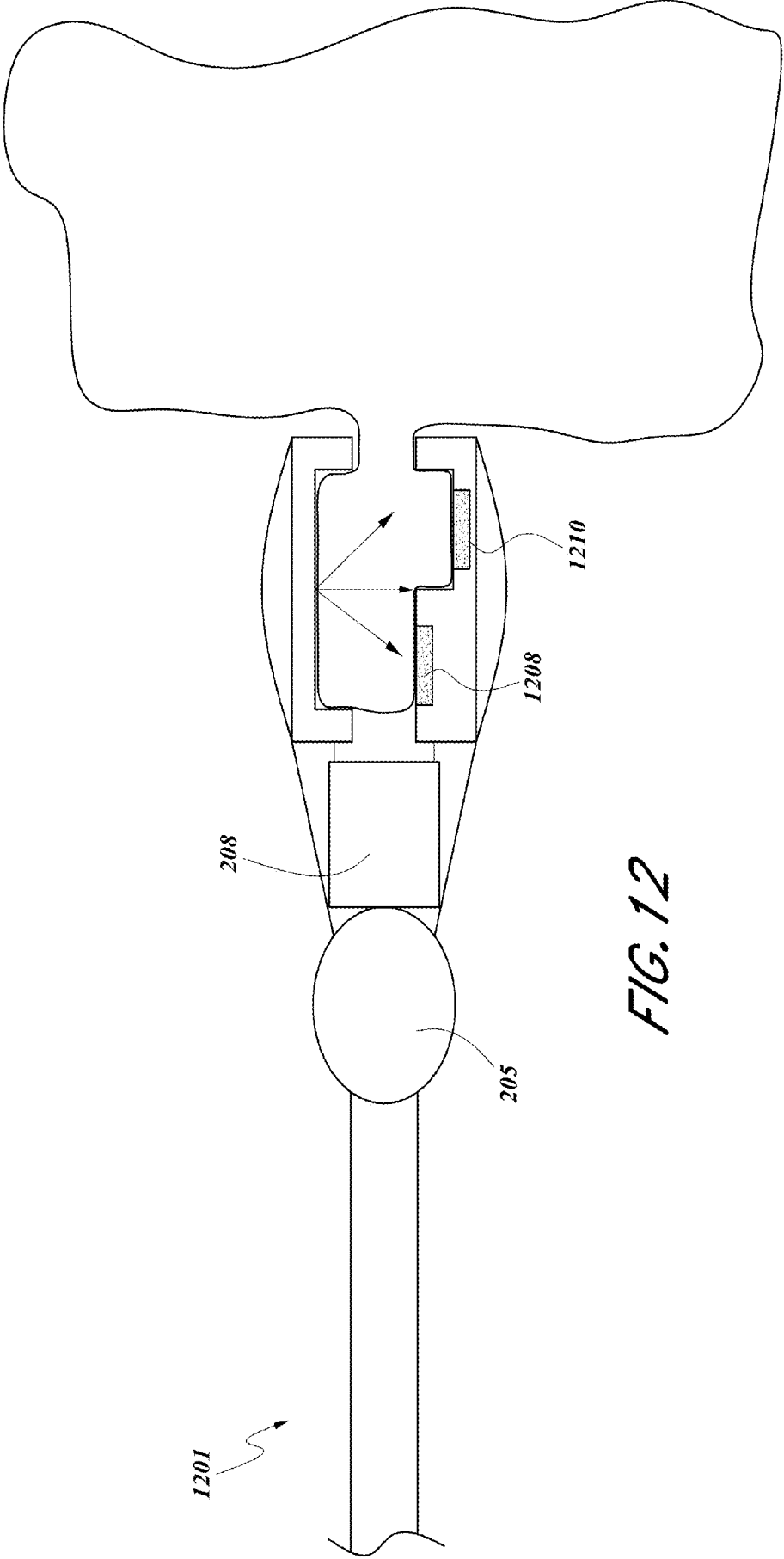

FIG. 12

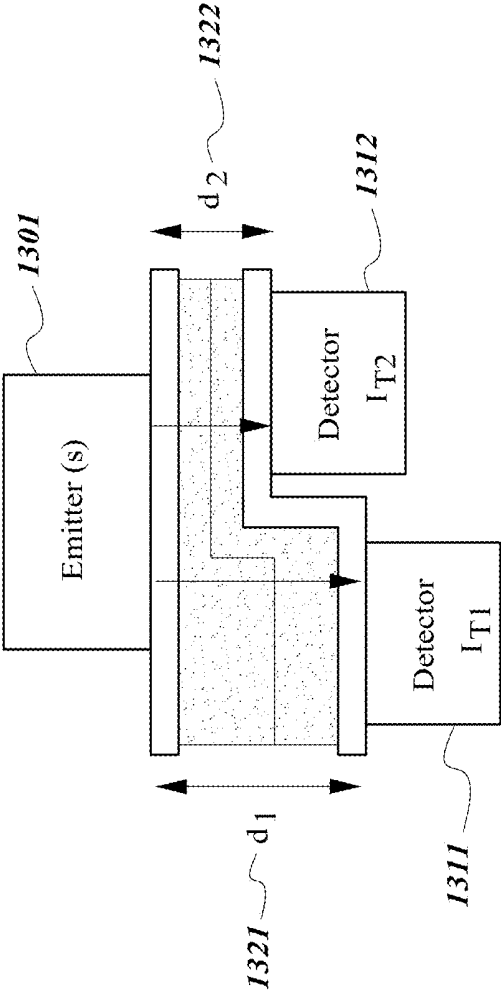

FIG. 13

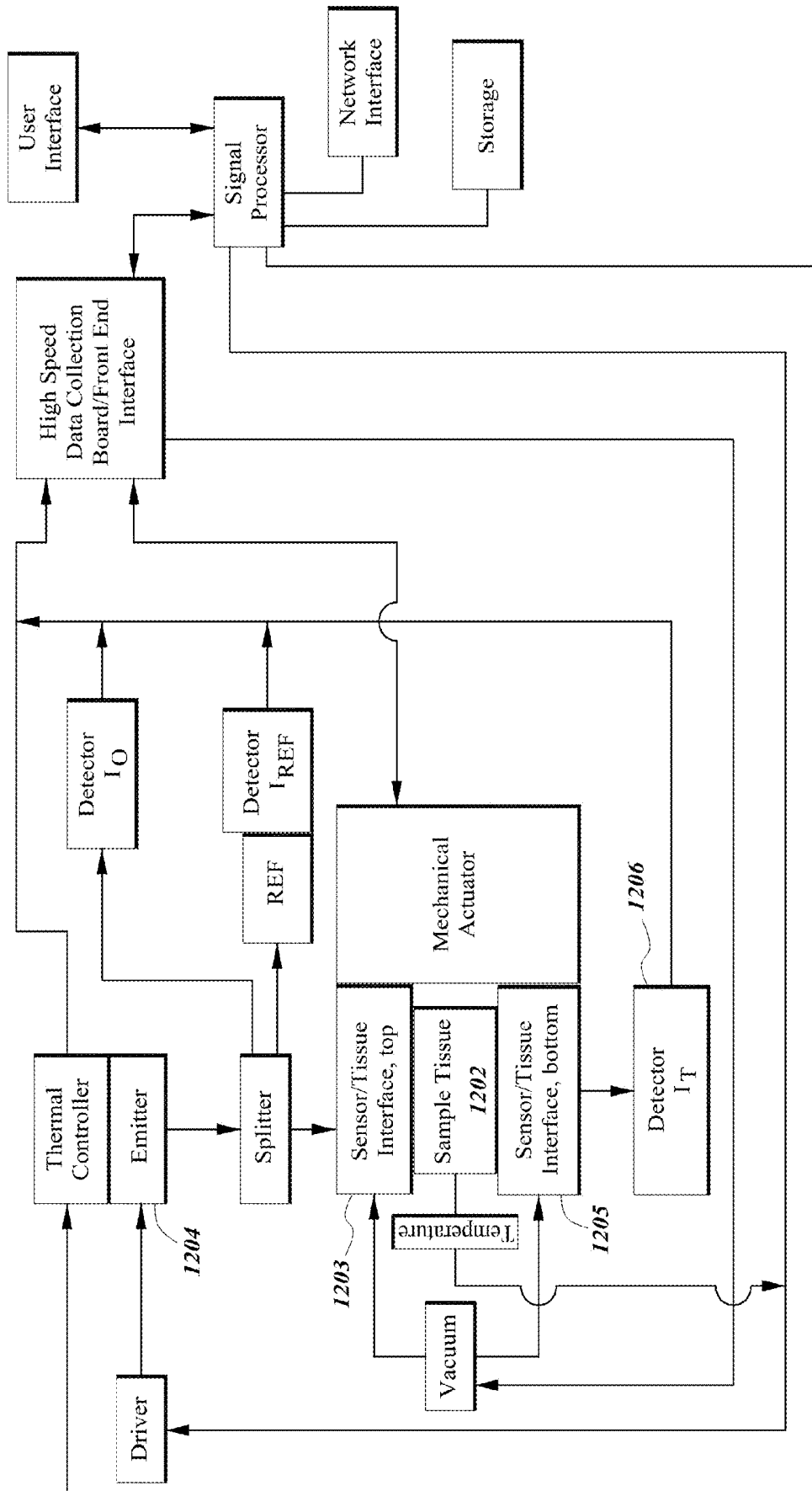

FIG. 14

NON-INVASIVE OPTICAL PHYSIOLOGICAL DIFFERENTIAL PATHLENGTH SENSOR

INCORPORATION BY REFERENCE TO ANY PRIORITY APPLICATIONS

[0001] This application claims priority benefit under 35 U.S.C. §119(e) of U.S. Provisional Application No. 62/165,618, filed May 22, 2015, titled “NON-INVASIVE OPTICAL PHYSIOLOGICAL SENSOR,” and U.S. Provisional Application No. 62/233,126, filed Sep. 25, 2015, titled “NON-INVASIVE OPTICAL PHYSIOLOGICAL DIFFERENTIAL PATHLENGTH SENSOR,” each of which is hereby incorporated by reference in its entirety. Any and all applications for which a foreign or domestic priority claim is identified in the Application Data Sheet as filed with the present application are hereby incorporated by reference under 37 CFR 1.57.

FIELD OF THE DISCLOSURE

[0002] The present disclosure relates to the field of non-invasive optical based physiological monitoring sensors that have a differential pathlength for the light to traverse through tissue.

BACKGROUND

[0003] Devices capable of spectroscopic analysis generally include a light source(s) characterized by a plurality of wavelengths of known spectra transmitting optical radiation into or reflecting off a measurement site, such as, body tissue carrying pulsing blood and/or interstitial fluid. After attenuation by tissue and fluids of the measurement site, a photo-detection device(s) detects the attenuated light and outputs a detector signal(s) responsive to the detected attenuated light. A signal processing device(s) process the detector(s) signal(s) and outputs a measurement indicative of a blood and/or interstitial fluid constituent of interest, such as glucose, oxygen, methemoglobin, total hemoglobin, other physiological parameters, or other data or combinations of data useful in determining a physiological state or trend of wellness of a patient.

SUMMARY

[0004] This disclosure describes embodiments of non-invasive methods, devices, and systems for measuring a blood and/or interstitial fluid constituent (which may also be referred to as an analyte), and/or substance such as oxygen, carboxyhemoglobin, methemoglobin, total hemoglobin, glucose, proteins, lipids, a percentage thereof (e.g., saturation), or for measuring many other physiologically relevant patient characteristics. These characteristics can relate, for example, to pulse rate, hydration, trending information and analysis, and the like.

[0005] In an embodiment, the system includes a non-invasive sensor and a patient monitor communicating with the non-invasive sensor. The non-invasive sensor may include different architectures to implement some or all of the disclosed features. In addition, an artisan will recognize that the non-invasive sensor may include or may be coupled to other components, such as a network interface, and the like. Moreover, the patient monitor may include a display device, a network interface communicating with anyone or combination of a computer network, a handheld computing device, a mobile phone, the Internet, or the like. In addition,

embodiments may include multiple optical sources that emit light at a plurality of wavelengths and that are arranged from the perspective of a light detector as a point source.

[0006] In an embodiment, a non-invasive device is capable of producing a signal responsive to light attenuated by tissue at a measurement site. The device may comprise an optical source (made up of a plurality of light sources such as LEDs/SLEDs/Lasers within a 3 mm area) and one or a plurality of photodetectors. The one or plurality of photodetectors can be configured to detect the optical radiation from the optical source after attenuation by the tissue of the measurement site. The one or plurality of photodetectors also output a respective signal stream responsive to the detected optical radiation.

[0007] Certain embodiments of the present disclosure are configured to perform high speed spectral sweep analysis of the tissue being measured to non-invasively predict a patient's analyte levels, such as by way of non-limiting example, glucose levels. Informative spectral data can be obtained during the sweeping of specific wavelength regions of a patient's sample tissue. In previous configurations the spectral measurements are sensitive to sources of error, such as for example, fluctuations in the emitter (e.g., LED, SLED, and laser) power and temperature which can produce changes in the wavelength of emitted light. Rather than attempting to eliminate, to control, or to compensate for these sources of potential error, the present disclosure provides a system that uses these sources of fluctuation in the wavelength of the emitted light to its advantage. This sensitivity can be used advantageously to generate spectral sweeps over multiple wavelengths, by intentionally allowing the emitter temperature and/or the power to change. Accordingly, systems, devices and methods disclosed herein are used to monitor, control and/or adjust for, among other things, variations in emitter light source(s), emitter temperature(s), tissue temperature(s), and photodetector temperature (s) in order to use these sources to enhance the measurement process and reduce or eliminate unexpected or unwanted distortion in the collected spectral information that is reflective of blood and/or interstitial fluid constituents, such as, for example, glucose.

[0008] In an embodiment, the emitter is configured to receive a drive signal controlled by the processor. The drive signal comprises a drive current and a duty cycle, and the processor is configured to control the drive current and duty cycle. The drive current per cycle does not necessarily have a constant value, but rather, it can change in a controlled manner during a cycle such as, for example, linearly or logarithmically. Variation of the drive current and/or duty cycle can cause the emitter to emit light at varying wavelengths and powers. In some embodiments, a thermal controller is thermally coupled to the emitter to monitor and/or control the temperature of the emitter. The emitter is in thermal communication with the thermal controller which may include a temperature sensor, a thermoelectric cooler (such as, for example, a Peltier device), and a heat sink. The thermal controller is configured to receive a control signal from the processor and in response to such signal, adjust the operational temperature of the emitter to cause the emitter to emit light at varying wavelengths.

[0009] In some embodiments, data is collected at a high sampling rate (high speed) to obtain a larger quantity of spectral information than what can be collected using lower speed, averaged data collection methods. In some embodi-

ments, tissue optical volume is controlled by fixing the distance between the emitter(s) and detector(s) and by ensuring that the sample tissue fills the fixed distance for each measurement. The sample tissue being measured contains, among other things, accumulated interstitial fluid which possesses metabolic levels of blood constituents, such as glucose, in concentrations similar to that found in blood. The sample tissue size and volume is controlled to reduce distortion and to increase the quantity of useful spectral information collected. Accurate measurement and/or control of emitter temperature, tissue sample temperature, and photodetector temperature are obtained to help secure the collection of valuable and useful spectral information reflective of blood and/or interstitial fluid constituents, such as glucose.

[0010] In some embodiments, control of the environment in which data is collected is maintained to reduce or eliminate sources of measurement variation. Illustratively, the temperature of the sample tissue may be measured to account for thermal fluctuations in the sample tissue which may affect the sensor measurements. Additionally, the temperature of the sample tissue may be controlled, by using, for example, a thermal controller or a thermoelectric cooler, to maintain the sample tissue at a constant temperature. In addition or alternatively, parts of the sensor may be controlled to match the sample tissue temperature measured.

[0011] In certain embodiments, the temperature of the detector(s) is measured by, for example, a temperature sensor, to account for thermal fluctuations in the detector(s) and to compensate for such fluctuations in the processing of the obtained measurements. In some embodiments, a thermoelectric cooler may be used to maintain the detector(s) at a constant temperature.

[0012] According to an embodiment, an optical physiological measurement system comprises an emitter configured to emit light at a plurality of wavelengths. The system includes a splitter configured to receive the emitted light and split it into a main (or primary, or first) beam and a set (or plurality) of auxiliary beams such as second beam, third beam etc. The system also includes a set (or plurality) of detectors. The first (or main) set of detectors is configured to detect the first (or main) beam of transmitted light after the first (or main) beam has been attenuated by a sample tissue being measured at a measuring site. The first set of detectors outputs a first signal responsive to the transmitted light of the first beam attenuated by the sample tissue at two different pathlengths. The system includes a second detector configured to detect the second beam of transmitted light and to output a second signal responsive to the detected light of the second beam. The second beam is attenuated by an absorber with flat spectral response; hence the second detector outputs a second signal proportional to the bulk emitted light, which characterizes its emitted power. The system includes a third detector configured to detect the third beam of emitted light after the third beam has been attenuated by a reference absorption material installed inside the system. The third detector outputs a third signal responsive to the detected light of the third beam attenuated by the reference absorption material at a desired spectral profile, which characterizes its emitted spectra. Alternatively the beam splitter may have additional auxiliary beams directed to additional absorption filters with diverse spectral responses in order to excite additional detectors responsive to the desired additional spectra. The system also includes a pro-

cessor configured to receive signals responsive to the first (or main) and all other auxiliary signals to determine a bulk absorbance of an analyte in the sample tissue.

[0013] According to an embodiment, the system includes a splitter configured to receive and split the emitted light from said light source(s) into a plurality of beams (a first beam, a second beam, a third beam and a fourth beam). The split beams are ideally equivalent to one another, with only a power scaling factor being the difference between any two beams. The spectral content of each beam shall be the same. The system also includes a first detector set configured to detect the first beam of emitted light after the first beam has been attenuated by a sample tissue being measured at a measuring site at two different paths through the tissue. The first detector outputs signals responsive to the detected light of the first beam through the two different paths of tissue. The system includes a second detector configured to detect the second beam of emitted light and to output a second signal responsive to the detected light of the second beam. The system includes a third detector configured to detect the third beam of emitted light after the third beam has been attenuated by a reference absorption material installed inside the system. The third detector outputs a third signal responsive to the detected light of the third beam. The system includes a fourth detector configured to detect the fourth beam of emitted light after the fourth beam has been attenuated by a second reference absorption material or other absorption material with known absorbance installed inside the system. The fourth detector outputs a fourth signal responsive to the detected light of the fourth beam. The system also includes a processor configured to receive signals responsive to the first, second, third and fourth signals to determine a bulk absorbance of an analyte in the sample tissue.

[0014] According to an embodiment, a high speed data collection device is used to receive and convert the first, the second, the third, the fourth and any other desired output signals from an analog form to a digital form. The high speed data collection device includes a successive approximation register (SAR) analog-to-digital converter (ADC) to convert the plurality of detected signals from an analog form to a digital form for further processing.

[0015] In an embodiment, a tissue restriction apparatus, including an enclosure to receive the sample tissue, is used to control a distance between the emitter and the first detector. The tissue restriction apparatus may include a vacuum device configured to accumulate the sample tissue within the tissue restriction device. The tissue restriction device may also be configured to apply a pressure force to be distributed along the sample tissue within the enclosure. Illustratively, by way of non-limiting example, the tissue restriction apparatus can include a spring that is configured to apply pressure to the sample tissue at the measurement site to cause the sample tissue to be distributed substantially evenly throughout the measurement site. In some embodiments, the spring is controllable to enable adjustment of the applied pressure to the sample tissue so as to avoid the potential for occlusion of blood and/or interstitial fluid within the sample tissue. A tissue water volume within the measurement site may also be measured or estimated and used to compensate for differences between different tissue types. Different tissues have different compositions, and therefore the amount of water in the tissue from one location or subject to another will change. An estimation of this

volume may be determined based on age, gender, or other demographic information, or it may also be estimated through a pressure measurement.

[0016] According to an embodiment, a method of varying light emitted in a physiological sensor includes determining a temperature, a drive current, a forward voltage and a duty cycle. It is to be understood that each of these variables (temperature, drive current, forward voltage and duty cycle) may not need to be controlled to a constant value. Instead, each of these variables can be varied during measurement to achieve the purpose of varying the shape of light emitted in order to get the most information from the site. The method includes measuring a first indication of a physiological parameter. The method also includes altering at least one of the determined temperature, drive current, forward voltage, duty cycle, and shape of the emitter at a second time to cause the emitter to emit light at a second wavelength. The method further includes measuring a second indication of a physiological parameter. This method can be repeated as needed using different combinations of the variables to measure different indication(s) of a physiological parameter. Altering the determined temperature of the emitter can include using a circuitry-based temperature alteration device, which may include a Peltier device. Alternatively, the necessary temperature change can be obtained through the natural heat generated at the emitter device by the driving current and duty cycle according to the Joule's laws. In yet another embodiment, temperature control can be achieved passively using coupling fluid heated remotely to the desired temperature. In this embodiment, the fluid is dispensed to the measurement site area just prior to measurement and the site is brought into thermal equilibrium prior to measurement.

[0017] For purposes of summarizing the disclosure, certain aspects, advantages and novel features of the inventions have been described herein. It is to be understood that not necessarily all such advantages can be achieved in accordance with any particular embodiment of the inventions disclosed herein. Thus, the inventions disclosed herein can be embodied or carried out in a manner that achieves or optimizes one advantage or group of advantages as taught herein without necessarily achieving other advantages as can be taught or suggested herein.

BRIEF DESCRIPTION OF THE DRAWINGS

[0018] Throughout the drawings, reference numbers can be re-used to indicate correspondence between referenced elements. The drawings are provided to illustrate embodiments of the inventions described herein and not to limit the scope thereof.

[0019] FIG. 1 illustrates an embodiment of a physiological measurement system for non-invasively and invasively measuring blood analytes.

[0020] FIG. 2 illustrates a side view of an embodiment of a non-invasive sensor housing configured to measure a skin-fold pinch having a fixed distance between emitter(s) and detector(s).

[0021] FIG. 3 illustrates a block diagram of an embodiment of a physiological measurements system.

[0022] FIG. 4 illustrates a schematic diagram of the current driver of an embodiment of a patient monitoring system.

[0023] FIG. 5 illustrates an example of a detector response based on wavelengths measured and temperature variations.

[0024] FIG. 6 illustrates a block diagram of an embodiment of a physiological measurement system configured to

perform high speed spectral sweep analysis with two different detectors sampling light from two different paths through the tissue.

[0025] FIG. 7 illustrates a signal processed by a low fidelity data collection board in which emitters are modulated to sweep through a range of wavelengths.

[0026] FIG. 8 illustrates a signal processed by a high fidelity, high speed data collection board in which emitters are modulated to sweep through a range of wavelengths.

[0027] FIG. 9 illustrates results from an implementation of the disclosed high speed spectral sweep analysis system.

[0028] FIGS. 10A-D illustrate zoomed-in results from an implementation of the disclosed high speed spectral sweep analysis system.

[0029] FIG. 11 illustrates correlation between a reference concentration of glucose in sample solutions and a predicted concentration of glucose as determined by the disclosed high speed spectral sweep analysis system.

[0030] FIG. 12 illustrates the sensor from FIG. 1 and FIG. 2 that has two different photodiodes sampling light from two different paths through the tissue.

[0031] FIG. 13 illustrates a cross-sectional view of the embodiment described in FIG. 12.

[0032] FIG. 14 illustrates a block diagram of an embodiment of a physiological measurement system configured to perform high speed spectral sweep analysis with a mechanical actuator that can adjust and control the sample tissue volume.

DETAILED DESCRIPTION

[0033] FIG. 1 illustrates an embodiment of a monitoring system 100 that advantageously provides relatively frequent non-invasive measurements of a blood and/or interstitial fluid parameter, such as, for example, glucose, interspersed with relatively infrequent invasive measurements of the parameter. The monitoring system 100 is capable of communicating with networks, such as by way of non-limiting examples, the Internet, a wide-area network, or a local-area network, via a cellular component, a Wi-Fi connection, a Bluetooth interface, or the like. The monitoring system 100 has a monitor 110, an optical sensor 120, a sensor cable 130 electrically and mechanically interconnecting the monitor 110 and sensor 120, and an optional monitor-integrated test strip reader that accepts test strips 150 via a test strip slot 140. In an embodiment, the test strip reader measures blood glucose levels. In an embodiment, the monitoring system 100 individually calibrates the non-invasive optical sensor 120 measurements with intermittent test strip measurements to advantageously provide the accuracy of individualized test strip measurements at a much-reduced frequency of blood draws. Reduced blood draws is a substantial aid to persons who require frequent monitoring, for example in the case of monitoring blood glucose levels, to manage diabetes and related diseases. In an embodiment, the monitor 110 has a handheld housing including an integrated touch screen, or display 160 defining one or more input keys and providing a display of blood glucose levels among other features.

[0034] An optical sensor is described in detail with respect to U.S. patent application Ser. No. 13/646,659 titled Non-invasive Patient Assessment System and filed Oct. 5, 2012. A blood glucose monitor is described in detail with respect to U.S. patent application Ser. No. 13/308,461 titled Handheld Processing Device Including Medical Applications for Minimally and Non-invasive Glucose Measurements and

filed Nov. 30, 2011. Blood glucose monitors and sensors are described in detail with respect to U.S. patent application Ser. No. 13/449,307, titled Blood Analysis System, filed Apr. 17, 2012 and U.S. patent application Ser. No. 13/473,477, titled Personal Health Device, filed May 16, 2012. A blood glucose calibration system is described in detail with respect to U.S. patent application Ser. No. 13/726,539 titled Blood Glucose Calibration System and filed Dec. 24, 2012. All of the above referenced patent applications are assigned to Cercacor and incorporated by reference herein in their entireties.

[0035] The monitor 110 can advantageously include electronic processing, signal processing, and data storage devices capable of receiving signal data from the sensor 120, processing the signal data to determine one or more output measurement values indicative of one or more physiological parameters of a monitored patient, and displaying the measurement values, trends of the measurement values, combinations of measurement values, and the like.

[0036] The cable 130 connecting the sensor 120 and the monitor 110 can be implemented using one or more wires, optical fiber, flex circuits, or the like. In some embodiments, the cable 130 can employ twisted pairs of conductors in order to minimize or reduce cross-talk of data transmitted from the sensor 120 to the monitor 110. Various lengths of the cable 130 can be employed to allow for separation between the sensor 120 and the monitor 110. The cable 130 can be fitted with a connector (male or female) on either end of the cable 130 so that the sensor 120 and the monitor 110 can be connected and disconnected from each other. Alternatively, the sensor 120 and the monitor 110 can be coupled together via a wireless communication link, such as an infrared link, radio frequency channel, or any other wireless communication protocol and channel.

[0037] The monitor 110 can be attached to the patient. For example, the monitor 110 can include a belt clip or straps that facilitate attachment to a patient's belt, arm, leg, or the like. The monitor 110 can also include a fitting, slot, magnet, snap-click connector, or other connecting mechanism to allow the cable 130 and sensor 120 to be attached to the monitor 110.

[0038] The monitor 110 can also include other components, such as a speaker, power button, removable storage or memory (e.g., a flash card slot), an AC power port, and one or more network interfaces, such as a universal serial bus interface or an Ethernet port. For example, the monitor 110 can include a display 160 that can indicate a measurement of glucose, for example, in mg/dL. Other analytes and forms of display can also appear on the monitor 110.

[0039] In addition, although a single sensor 120 with a single monitor 110 is shown, different combinations of sensors and device pairings can be implemented. For example, multiple sensors can be provided for a plurality of differing patient types or measurement sites.

[0040] In an alternative embodiment, the monitor 110 does not include a display or test strip reader. In such an embodiment, the monitor 110 is configured to wirelessly communicate with a user device, such as a smartphone. Alternatively the monitor can wirelessly communicate with a cloud-based computing network to upload data, download parameters, and post-process collected data if advantageously recommended or necessary. Measurements obtained by the monitor 110 are wirelessly communicated to the user

device which is configured to receive and display the measurements and provide feedback to the user.

[0041] FIG. 2 illustrates an embodiment of the non-invasive optical sensor 120 of FIG. 1. The sensor 201 in the depicted embodiment is a hinged-clip type sensor that includes an enclosure 203 for receiving a skin-fold pinch (i.e., sample tissue) 202 of a patient. The enclosure 203 is formed by an upper section or emitter shell 204, which is pivotably connected with a lower section or detector shell 206. The emitter shell 204 can be biased with the detector shell 206 to close together around a pivot point 205 and thereby enclose sample tissue between the emitter and detector shells 204, 206 at a measurement site.

[0042] In an embodiment, the pivot point 205 advantageously includes a pivot capable of adjusting the relationship between the emitter and detector shells 204, 206 to apply appropriate pressure to the skin-fold pinch 202 of the measurement site. In another embodiment, the sensor 201 includes a spring (not shown) that causes the pressure force to be distributed along the sample tissue 202. The sensor includes a depth stop 208 which serves to define a fixed distance between the emitter shell 204 and the detector shell 206, thereby defining a known path length between emitter (s) and detector(s).

[0043] The pressure exerted by the spring can be controllably variable. In an embodiment, the spring pressure exerted on the skin-fold pinch 202 is taken into account during calculation of the measurement. For example, measurements taken by the optical sensor 201 are sensitive to pressure. The greater the pressure that is exerted on the skin-fold pinch 202, the smaller the potential measured signal (which may also referred to as plethysmograph) becomes. With sufficient pressure, the sample tissue 202 can be occluded, and no plethysmograph will be detected. Spring pressure can also affect the shape of the plethysmograph and the physiological composition of the material affected by the pulse wave that generates the plethysmograph. For example, during glucose measurements, pressure applied by the spring can force glucose out and away from the sample tissue 202 in the measurement site. Thus, during measurement, a known spring pressure or effect on the sample tissue 202 in the measurement site can be taken into account to adjust the determined measurements. In some embodiments, spring pressure is predetermined at manufacture and encoded onto a memory device (not shown) in of the sensor 201. In some embodiments, a pressure sensor or other type of sensor is used on the sensor 201 to determine a current pressure exerted by the spring. In some embodiments, a general estimate or compensation for spring pressure is used without measuring or otherwise determining specific spring pressure effects by each individual sensor 201.

[0044] The emitter shell 204 can position and house various emitter components of the sensor 201. It can be constructed of reflective material (e.g., white silicone or plastic) and/or can be metallic or include metalized plastic (e.g., including carbon and aluminum) to possibly serve as a heat sink. The emitter shell 204 can also include absorbing opaque material, such as, for example, black or grey colored material, at various areas, such as on one or more flaps (not shown), to reduce access of ambient light entering the measurement site and the sensor 201.

[0045] The detector shell 206 can position and house one or more detector portions of the sensor 201. The detector

shell **206** can be constructed of reflective material, such as white silicone or plastic. Such materials can increase the usable signal at a detector by forcing light back into the tissue and measurement site. The detector shell **206** can also include absorbing opaque material at various areas (not shown) to reduce ambient light entering the measurement site and the sensor **201**. The opaque material of the detector shell **206** may also serve the purpose of reducing light piping from the emitter **204** to the detector **206** and force all the light from the emitter to pass through the tissue sample.

[0046] Care may be taken when physically coupling the surface of the skin **202** to the surface of the emitter shell **204** or detector shell **206**. In some embodiments a tissue shaper in the form of a cavity **203** is provided to permit the tissue sample to fill the space in an evenly distributed manner, without overlap of sample tissue **202**. In some embodiments a vacuum chamber (not shown) is used to help distribute the sample tissue **202** appropriately. The vacuum chamber can also provide a controlled amount of suction pressure to help achieve a proper distribution of blood and/or interstitial fluid within the sample tissue **202**.

[0047] In certain embodiments, the optical properties of the sample tissue **202** can be stabilized by application of a coupling agent, such as, by way of non-limiting example, a perfluorinated liquid. One such perfluorinated liquid is known by the brand name Fluorinert™, manufactured by 3M Company, of St. Paul, Minn. A coupling agent reduces variations in surface reflection of the sample tissue **202**, thereby improving accuracy of the non-invasive measurement of the sample tissue **202**. An additional feature of the coupling agent is that it may provide temperature stabilization of the sample tissue **202**.

[0048] FIG. 12 illustrates an embodiment of the non-invasive optical sensor **120** of FIG. 1. The sensor **120** is similar to that described in FIG. 2 with the difference that FIG. 12 illustrates an embodiment with multiple photodiode channels. The two photodiode channels, **1208**, **1210** are located at different heights from the emitters such that when the tissue fills the space between the emitter and detector it will create two distinct light paths that have different lengths. The height difference for the two photodiodes can be optimized at a height that doesn't stretch the skin too much, but allows for a maximum difference in heights. Stretching of the skin can cause scattering changes in the tissue which effects the optical signal detected. The ideal height difference would create minimal stretching in the skin, not have scattering transients during sensor placement and be repeatable for multiple sensor placements. The height difference between detectors would preferably be between 0.2 mm and 1 mm. The step between the two photodiode heights could be a right angle, but in a some embodiments it can be a 45 degree angle with rounded corners in order for the skin in the tissue sample to not get caught on a sharp edge. Other embodiments could include more of a curved surface than a straight surface. FIG. 12 depicts the two photodiodes **1208** and **1210** running from back to front of the sensor, but some embodiments can have the two photodiodes run transverse to the sensor head such that they both see similar parts of tissue. All other embodiments described for the sensor in FIG. 2 can still apply to the sensor in FIG. 11.

[0049] FIG. 3 illustrates an example of a data collection system **300**, which can be embodied in the devices of FIGS. 1-2 and 12. In certain embodiments, the data collection

system **300** non-invasively measures a blood and/or interstitial fluid analyte, such as oxygen, carboxyhemoglobin, met-hemoglobin, total hemoglobin, glucose, proteins, lipids, a percentage thereof (e.g., saturation) or for measuring many other physiologically relevant patient characteristics, including other characteristics described herein. The system **300** can also measure additional blood and/or interstitial fluid analytes and/or other physiological parameters useful in determining a physiological state or trend of wellness of a patient.

[0050] The data collection system **300** can be capable of measuring optical radiation from the measurement site. For example, in some embodiments, the data collection system **300** can employ photodiodes defined in terms of area. In an embodiment, the area is from about 0.25 mm²-5 mm² (or higher) that is capable of detecting about 100 nanoamps (nA) or less of current resulting from measured light at full scale. In addition to having its ordinary meaning, the phrase "at full scale" can mean light saturation of a photodiode amplifier (not shown) or the voltage swing across a region of the circuitry that is defined by its linear region within the limits of electrical analog and digital saturation. Of course, as would be understood by a person of skill in the art from the present disclosure, various other sizes and types of photodiodes can be used with the embodiments of the present disclosure with diverse capability of current detection.

[0051] The data collection system **300** can measure a range of approximately about 1 nA to about 1000 nA full scale. The data collection system **300** can also include sensor front-ends that are capable of processing and amplifying current from the detector(s) at signal-to-noise ratios (SNRs) of about 100 decibels (dB) or more, such as about 120 dB in order provide sufficient signal quality to measure various desired analytes. The data collection system **300** can operate with a lower SNR if less accuracy and/or precision is desired for an analyte like glucose.

[0052] The data collection system **300** can measure analyte concentrations, including glucose, at least in part by detecting light attenuated by sample tissue **302** at a measurement site. The sample tissue **302** can be at any location on a patient's body, such as a skin-fold pinch, the patient's purlicue (skin web between the thumb and index finger), ear lobe, nasal septum, finger, foot, or the like.

[0053] In the depicted embodiment, the system **300** includes an optional tissue thickness adjuster or tissue shaper **305**, which can include one or more protrusions, bumps, lenses, vacuums, or other suitable tissue-shaping mechanisms. In certain embodiments, the tissue shaper **305** is a flat or substantially flat surface that can be positioned proximate the sample tissue **302** at the measurement site and that can apply sufficient pressure to cause the sample tissue **302** to be flat or substantially flat. In other embodiments, the tissue shaper **305** is a convex or substantially convex surface with respect to the measurement site. Many other configurations of the tissue shaper **305** are possible. Advantageously, in certain embodiments, the tissue shaper **305** reduces thickness of the sample tissue **302** at the measurement site while preventing or reducing occlusion. Reducing thickness of the sample tissue **302** can advantageously reduce the amount of attenuation of the emitted light because there is less tissue through which the light must

travel. Shaping the tissue into a convex (or alternatively concave) surface can also provide more surface area from which light can be detected.

[0054] The embodiment of the data collection system 300 shown also includes an optional noise shield 303. In an embodiment, the noise shield 303 can be advantageously adapted to reduce electromagnetic noise while increasing the transmittance of light from the sample tissue 302 to one or more detector(s) 306 (described below).

[0055] The data collection system 300 can include a sensor 301 (or multiple sensors) that is coupled to a processing device or physiological monitor 309. In an embodiment, the sensor 301 and the monitor 309 are integrated together into a single unit. In another embodiment, the sensor 301 and the monitor 309 are separate from each other and communicate with one another in any suitable manner, such as via a wired or wireless connection. The sensor 301 and monitor 309 can be attachable and detachable from each other for the convenience of the user or caregiver, for ease of storage, for sterility issues, or the like. The sensor 301 and the monitor 309 will now be further described.

[0056] In the depicted embodiment shown in FIG. 3, the sensor 301 includes one or more emitters at a single or multiple locations 304, a tissue shaper 305, one or more detector(s) at a single or multiple locations 306, and a front-end interface 308. The emitters 304 can serve as the source of optical radiation transmitted towards a measurement site 302. As will be described in further detail below, the emitters 304 can include one or more sources of optical radiation, such as LEDs (including, by way of non-limiting example, top-emitting LEDs, side-emitting LEDs, superluminescent LEDs), laser diodes, incandescent bulbs with appropriate frequency-selective filters, combinations of the same, or the like. In an embodiment, the emitters 304 include sets of optical sources that are capable of emitting visible and near-infrared optical radiation.

[0057] In some embodiments, the emitters 304 are used as a point optical source, and thus, the one or more optical sources of the emitters 304 can be located within a close distance to each other, such as within about 2 mm to about 4 mm from each other. The emitters 304 can be arranged in an array, such as is described in U.S. Publication No. 2006/0211924, filed Sep. 21, 2006, titled "Multiple Wavelength Sensor Emitters," the disclosure of which is hereby incorporated by reference in its entirety. In particular, the emitters 304 can be arranged at least in part as described in paragraphs [0061] through [0068] of the aforementioned publication, which paragraphs are hereby incorporated specifically by reference. Other relative spatial relationships can be used to arrange the emitters 304.

[0058] The emitters 304 of the data collection system 300 can emit, in certain embodiments, combinations of optical radiation in various bands of interest. For example, in some embodiments, for analytes like glucose, the emitters 304 can emit optical radiation at three (3) or more wavelengths between about 1330 nm to about 1660 nm. Depending on the available technology of optical emitters and detectors, wavelength values up to 1700 nm or even 1800 nm can be used to improve the accuracy of an analyte. In particular, the emitters 304 can emit optical radiation at or about 1370 nm, about 1540 nm, about 1585 nm, and about 1610 nm. In some circumstances, the use of three wavelengths within about 1540 nm to about 1610 nm enables sufficient SNRs of about

100 dB, which can result in a measurement accuracy of about 10 mg/dL or better for analytes like glucose.

[0059] In other embodiments, the emitters 304 can use two (2) wavelengths within about 1540 nm to about 1610 nm, which can result in a measurement accuracy of about 20 mg/dL or better for analytes like glucose. Furthermore, in some embodiments, the emitters 304 can emit light at wavelengths above about 1670 nm. Measurements at these wavelengths can be advantageously used to compensate for or confirm the contribution of protein, water, and other non-hemoglobin species exhibited in measurements for analytes like glucose conducted between about 1540 nm and about 1610 nm. Of course, other wavelengths and combinations of wavelengths can be used to measure analytes and/or to distinguish other types of tissue, fluids, tissue properties, fluid properties, combinations of the same, or the like.

[0060] For example, the emitters 304 can emit optical radiation across other spectra for other analytes. In particular, the emitters 304 can employ light wavelengths to measure various blood analytes or percentages (e.g., saturation) thereof. For example, in one embodiment, the emitters 304 can emit optical radiation in the form of pulses at wavelengths about 905 nm, about 1050 nm, about 1200 nm, about 1300 nm, about 1330 nm, about 1610 nm, about 1640 nm, and about 1665 nm. In another embodiment, the emitters 304 can emit optical radiation ranging from about 860 nm to about 950 nm, about 950 nm to about 1100 nm, about 1100 nm to about 1270 nm, about 1250 nm to about 1350 nm, about 1300 nm to about 1360 nm, and about 1590 nm to about 1700 nm. Of course, the emitters 304 can transmit any of a variety or combination of wavelengths of ultra-violet, visible and near-infrared optical radiation.

[0061] Due to the different responses of analytes to the different wavelengths, certain embodiments of the data collection system 300 can advantageously use the measurements at these different wavelengths to improve the accuracy of measurements. For example, the measurements of water from visible and infrared light can be used to compensate for water absorbance that is exhibited in the near-infrared wavelengths.

[0062] As briefly described above, the emitters 304 can include sets of light-emitting diodes (LEDs) as their optical source. The emitters 304 can use one or more top-emitting LEDs. In particular, in some embodiments, the emitters 304 can include top-emitting LEDs emitting light at about 850 nm to 1350 nm. The emitters 304 can also use superluminescent LEDs (SLEDs) or side-emitting LEDs. In some embodiments, the emitters 304 can employ SLEDs or side-emitting LEDs to emit optical radiation at about 1300 nm to about 1800 nm. Emitters 304 can use SLEDs or side-emitting LEDs to transmit near infrared optical radiation because these types of sources can transmit at high power or relatively high power, e.g., about 40 mW to about 150 mW. This higher power capability can be useful to compensate for or to overcome the greater attenuation of these wavelengths of light in tissue and water.

[0063] The data collection system 300 also includes a driver 311 that drives the emitters 304. The driver 311 can be a circuit or the like that is controlled by the monitor 309. For example, the driver 311 can provide pulses of current to the emitter 304. In an embodiment, the driver 311 drives the emitters 304 in a progressive fashion, such as in an alternating manner. The driver 311 can drive the emitters 304

with a series of pulses of about 1 milliwatt (mW) for some wavelengths that can penetrate tissue relatively well, and from about 40 mW to about 150 mW for other wavelengths that tend to be significantly absorbed in tissue. In an embodiment, an array of drivers can be used to drive multiple emitters at the same time at different duty cycles, different frequencies, and various current drives. As mentioned above, the current does not have to be a pulse or a series of pulses. For example a linear ramping, logarithmic or exponential current can be selected as the drive current during the cycles. A skilled artisan will appreciate that a wide variety of other driving powers and driving methodologies can be used in various embodiments.

[0064] The detector(s) 306 capture and measure light attenuated (or reflected) by the sample tissue 302 at the measurement site. For example, the detector(s) 306 can capture and measure light transmitted from the emitters 304 that has been attenuated or reflected from the sample tissue 302 in the measurement site. The detector(s) 306 can output a detector signal (which may also be referred to as measurement data) 307 responsive to the light captured or measured. The detector(s) 306 can be implemented using one or more photodiodes, phototransistors, or the like. The detector(s) can be placed within a defined location or sparsely placed over many locations. In an embodiment, the detector can include capabilities to detect light which is both transmitted through the tissue and reflected from the tissue. In an embodiment, the system uses measurements from both the transmitted and/or reflected light in the determination of physiological parameters. The system can also make a determination of which signal (transmitted through or reflected) provides the best signal and use that signal. Alternatively or in addition, the system can make a quality of signal determination for each of the transmitted through or reflected signals and use the quality information to weight the signals in order to determine a combined signal. The quality determination and combining of the signals can be performed at startup or throughout the measurement process.

[0065] The front end interface 308 provides an interface that adapts or conditions the output of the detector(s) 306, which is responsive to desired physiological parameters. For example, the front end interface 308 can adapt or condition a detector signal 307 received from one or more of the detector(s) 306 into a form that can be processed by the monitor 309, for example, by a signal processor 310 in the monitor 309. The front end interface 308 can have its components assembled in the sensor 301, in the monitor 309, in the connecting cabling 130 (if used), in combinations of the same, or the like. The location of the front end interface 308 can be chosen based on various factors including space desired for components, desired noise reductions or limits, desired heat reductions or limits, and the like.

[0066] The front end interface 308 can be coupled to the detector(s) 306 and to the signal processor 310 using a bus, wire, electrical or optical cable, flex circuit, or some other form of signal connection. The front end interface 308 can also be at least partially integrated with various components, such as the detector(s) 306. For example, part of the front end interface can be built into the detector package while the remaining can be placed outside the detector package. The front end interface 308 can include one or more integrated circuits that are on the same circuit board as the detector(s) 306. Other configurations can also be used.

[0067] The front end interface 308 can be implemented using one or more amplifiers, such as transimpedance amplifiers (TIAs) that are coupled to one or more analog-to-digital converters (ADCs) (which can be in the monitor 309), such as a successive approximation register (SAR) ADC. A transimpedance-based front end interface 308 can employ single-ended circuitry, differential circuitry, and/or a hybrid configuration. A transimpedance-based front end interface 308 can be useful for its sampling rate capability and its freedom in modulation/demodulation algorithms. For example, this type of front end interface 308 can advantageously facilitate the sampling of the ADCs being synchronized with the pulses emitted from the emitters 304.

[0068] The ADC or ADCs can provide one or more outputs into multiple channels of digital information for processing by the signal processor 310 of the monitor 309. Each channel can correspond to a signal output from a detector 306.

[0069] In some embodiments, a programmable gain amplifier (PGA) can be used in combination with a transimpedance-based front end interface 308. For example, the output of a transimpedance-based front end interface 308 can be output to a PGA that is coupled with an ADC in the monitor 309. A PGA can be useful in order to provide another level of amplification and control of the stream of signals from the detector(s) 306. Alternatively, the PGA and ADC components can be integrated with the transimpedance-based front end interface 308 in the sensor 301.

[0070] In another embodiment, the front end interface 308 can be implemented using switched-capacitor circuits. A switched-capacitor-based front end interface 308 can be useful for, in certain embodiments, its resistor-free design and analog averaging properties. In addition, a switched-capacitor-based front end interface 308 can be useful because it can provide a digital signal to the signal processor 310 in the monitor 309.

[0071] As shown in FIG. 3, the monitor 309 can include the signal processor 310 and a user interface, such as a display 312. The monitor 309 can also include optional outputs alone or in combination with the display 312, such as a storage device 314 and a network interface 316. In an embodiment, the signal processor 310 includes processing logic that determines measurements for desired analytes, such as glucose, based on the signals received from the detector(s) 306. The signal processor 310 can be implemented using one or more microprocessors or subprocessors (e.g., cores), digital signal processors, application specific integrated circuits (ASICs), field programmable gate arrays (FPGAs), combinations of the same, and the like.

[0072] The signal processor 310 can provide various signals that control the operation of the sensor 301. For example, the signal processor 310 can provide emitter control signals to the driver 311. These control signals can be used to modulate the emitted wavelengths from the emitter(s) 304. As also shown, an optional memory 313 can be included in the front-end interface 308 and/or in the signal processor 310. This memory 313 can serve as a buffer or storage location for the front-end interface 308 and/or the signal processor 310, among other uses.

[0073] The user interface 312 can provide an output, e.g., on a display, for presentation to a user of the data collection system 300. The user interface 312 can be implemented as a touch-screen display, an LCD display, an organic LED display, or the like. In addition, the user interface 312 can be

manipulated to allow for measurement on the non-dominant side of patient. For example, the user interface 312 can include a flip screen, a screen that can be moved from one side to another on the monitor 309, or can include an ability to reorient its display indicia responsive to user input or device orientation. In alternative embodiments, the data collection system 300 can be provided without a user interface 312 and can simply provide an output signal to a separate display or system.

[0074] A storage device 314 and a network interface 316 represent other optional output connections that can be included in the monitor 309. The storage device 314 can include any computer-readable medium, such as a memory device, hard disk storage, EEPROM, flash drive, or the like. The various software and/or firmware applications can be stored in the storage device 314, which can be executed by the signal processor 310 or another processor of the monitor 309. The network interface 316 can be a serial bus port (RS-232/RS-485), a Universal Serial Bus (USB) port, an Ethernet port, a wireless interface (e.g., Wi-Fi such as any 802.Ix interface, including an internal wireless card), or other suitable communication device(s) that allows the monitor 309 to communicate and share data with other devices. The monitor 309 can also include various other components not shown, such as a microprocessor, graphics processor, or controller to output the user interface 312, to control data communications, to compute data trending, or to perform other operations.

[0075] Although not shown in the depicted embodiment, the data collection system 300 can include various other components or can be configured in different ways. For example, the sensor 301 can have both the emitter 304 and detector(s) 306 on the same side of the measurement site 302 and use reflectance to measure analytes. The data collection system 300 can also include a sensor that measures the power of light emitted from the emitter 304 by splitting the beam from the emitter 304 and directing to one of the photodiode channels 306 without passing the beam through the sample tissue 302. The data collection system 300 can also include a sensor that measures light that has passed through a reference material in order to track wavelength shifts in the emitter 304. Light that passes through the reference material will be attenuated in a known manner. Thus a change in wavelength will create a predictable change in real time. This will allow for real-time wavelength tracking that can be used to adjust for emitter variation and/or to determine whether the probe is accurate enough for use. One such reference material can be a cell filled with water. Another such reference material is didymium which has an absorption peak similar to water. Didymium's absorption peak is around 1490-1510 nm. If the reference material has an absorption that varies with temperature the temperature of the reference material can be monitored and used for compensation in an algorithm or the reference material can be controlled to a specified temperature.

[0076] FIG. 4 illustrates a block diagram of an embodiment of the system 400 illustrating further details of the devices of FIGS. 1-3. The system 400 includes an address controller 422, a current controller 424, and an address decoder 430, among other components. The system 400 can function at least in part like one or more of the patient monitoring systems described in U.S. Pat. No. 8,688,183 (the '183 patent), such as with respect to at least FIGS. 4, 5, 7A, 7B, 8, and 9 of the '183 patent. The disclosure of the

'183 patent is incorporated in its entirety by reference herein. In addition to the components of the patient monitoring systems described in the '183 patent, the system 400 includes an analog multiplexer (mux) 436.

[0077] The components of the system 400 can advantageously enable use of addressing and an analog multiplexing. The addressing information can be used, in part, to limit or reduce a number of conductors that may be required for transmitting signals from, for example, the sensor 120 or the cable 130 to the monitor 110. Accordingly, the potential of harmful crosstalk between conductors can be reduced as a result of fewer conductors. In addition, cables associated with the present disclosure may advantageously use fewer larger heavily shielded driver conductors, and therefore, may be less costly to produce and be less rigid or stiff and thus more ergonomic for a wearer of a sensor.

[0078] The address controller 422 and the current controller 424 can precisely control activation of the light source 434 in response to instructions (for instance, data, clock, and latch signals) from a processor 420. Such control circuitry can be used to perform, for example, high speed spectral sweep analysis as described in more detail below. The address controller 422 can output an address, such as, for example, a binary number, to the decoder 430 via N conductors. The decoder 430 can decode the address received via the N conductors and identify particular LED(s) of the light source 434 to be connected to the current controller 424. Once connected, current can flow through the particular LED, thereby activating it to irradiate tissue.

[0079] In an embodiment, one LED node may be energized at a time, and in further embodiments, time spacing or a gap can be provided between consecutive activations to guard against interference at the detector 306 by light of differing wavelengths. The gap, or no LED activation, can occur between activations of LEDs, and the gap can include one of the 2^N addressable locations such that an all-off condition is specifically addressable by the processor 420.

[0080] The current controller 424 includes a digital-to-analog converter (DAC) 426 configured to convert digital signals from the processor 420 into analog output. The DAC 426 can control light saturation by allowing for the fine tuning of the output drive current. The DAC 426 can receive clock and data signals from the processor 420 and a latching signal dictating when the DAC should lock the data on the data signal and stabilize the output drive current.

[0081] The output of the DAC 426 is provided to a plurality of amplifiers 428 which, in an embodiment, can include precision voltage-to-current amplifiers (or trans-conductance amplifiers—TCA) that adjust output currents based on one or more input voltages. In this embodiment, the current controller 424 can output two different currents i_1 and i_2 via the plurality of amplifiers 428 according to, in some instances, the voltage output by the DAC 426 as well as an output signal from the analog mux 436. The output of the plurality of amplifiers 428 can, in turn, be provided as the driving current to the LEDs of the light source 434. FIG. 4 shows output current i_1 communicating with the nodes of a first group of LEDs, Group A, and the output current i_2 communicating with the nodes of a second group of LEDs, Group B. In one example, the output current i_1 may be about 0 to about 80 mA, while the output current i_2 may comprise about 0 to about 800 mA. An artisan will recognize that other embodiments may advantageously employ other currents and/or have more or less groups.

[0082] The address controller 422 can output the same address to the analog mux 436 via N conductors as was output to the decoder 430. The address controller 422 can, for instance, output an address to the decoder 430 and the analog mux 436 in parallel with one another or at substantially the same time. The analog mux 436 can use the address received via the N conductors to identify an input of multiple inputs of the analog mux 436 that is associated with the address. For example, a received binary set of N bits can be identified as associated with a particular input of the analog mux 436 according to a mapping. In response to receiving the address from the address controller 422, the analog mux 436 can connect the identified input of the analog mux 436 associated with the address to the output of the analog mux 436 to output a signal received via the identified input to the front-end interface 418 and the current controller 424.

[0083] The decoder 430 and the analog mux 436 can furthermore have a common one-to-one mapping for a particular address to a particular LED of the light source 434. When the decoder 430 may receive a particular address corresponding to activation of a particular LED of the light source 434, the analog mux 436 can map the same particular address to an input of the analog mux 436 that may be connected to the drain of the of the same particular LED. Thus, when the decoder 430 activates the particular LED of the light source 434, the analog mux 436 may function to pass the voltage associated with the activated LED to the front-end interface 418 and the current controller 424. For example, if the address controller 422 outputs an address which the decoder 430 decodes to correspond to the output D_2 , the decoder 430 can activate the output D_2 so that the corresponding LED of the light source 434 irradiates. At substantially the same time, the analog mux 436 can receive the same address and accordingly connect the input A_0 to the output of the analog mux 436, so the analog mux 436 communicates the forward voltage V_2 of the irradiating LED to the front-end interface 418 and the plurality of amplifiers 428 of the current controller 424. Information of the forward voltage of an activated LED can advantageously help to enhance the algorithms used to calculate the irradiated power and irradiated wavelength spectra, which will further be used to improve the accuracy of the measured analyte.

[0084] Of course, those skilled in the art will appreciate that the aforementioned methodology can be expanded using multiple address decoders, DACs and analog muxes to allow the multiple driving of multiple emitters at the same time. Furthermore, the availability of FPGAs (Field Programmable Gate Arrays) is making it possible to integrate multiple address decoder functionality into a single part. Also, FPGAs may be programmed to provide multiple shape/waveform of currents for the emitters.

[0085] The system 400 additionally or alternatively includes a temperature sensor 438. The temperature sensor 438 can be used to measure the temperature near one or more of the LEDs of the light source 434 or for providing a measurement of the bulk temperature near the light source 434. The temperature sensor 438 can provide a temperature signal responsive to the measured temperature to the front-end interface 418. In an embodiment, the temperature sensor 438 can include multiple temperature sensors 436 positioned at different locations near the different LEDs of the light source 434. The particular temperature sensor 438 may be closer to an activated LED of the light source 434 than another temperature sensor 438 of the multiple temperature

sensors 436 so that a more accurate temperature reading of the activated LED can be determined. The system can also include multiple temperature sensors to allow the temperature reading of the tissue sites, and detectors. Information of the temperature of an activated LED can advantageously help to enhance the algorithms used to correct for the irradiated power and irradiated wavelength spectra, which will further be used to improve the accuracy of the measured analyte.

[0086] The system 400 further includes a heat pump 440. The heat pump 440 can be placed near one or more of the LEDs of the light source 434 and controlled by the processor 420 to remove, to add, or to control the heat near the light source 434. The heat pump can also be used to control and change the temperature of the light source(s). In an embodiment, the heat pump 440 can be a Peltier pump or device. In another embodiment the heat pump 440 can be a passive heat sink. In another embodiment there could be no heat pump 440 in a case where it is desired for the temperature to sweep a large range in order to naturally sweep a large wavelength range. In an embodiment, the heat pump 440 can include multiple heat pumps disposed at different locations near the different LEDs of the light source 434. The particular heat pump may be closer to an activated LED of the light source 434 so that more heat near the activated LED of the light source 434 can be controlled than if another heat pump of the multiple heat pumps were activated. In another embodiment, the decoder 430 itself can additionally or alternatively be used to control the heat pump 440. Moreover, in some embodiments, one or more heat pumps can be disposed near one or more photodetectors 306 used to detect light irradiated by the light source 434.

[0087] The front-end interface 418 can filter and pre-process received signals and output filtered and processed signals to the processor 420. The front-end interface 418 may, for example, include one or more high-pass filters, analog line-drivers, programmable gain amplifiers (PGAs), analog-to-digital converters (ADCs), or the like for processing a voltage signal from the analog mux 436 or the temperature signal(s) from the temperature sensor(s) 438.

[0088] While the processor 420 may receive the output filtered and processed signals from the front-end interface 418, the processor 420 can use information from the received signals to control components of the system 400 and determine measurement values for one or more monitored parameters of a patient. In one example, the processor 420 can determine the forward voltage of an activated LED of the light source 434 to, for instance, control an emitted wavelength and power output of the activated LED. The processor 420 can also determine a temperature measured by the temperature sensor 438 to further refine this predicted centroid wavelength or wavelength distribution and power output of the activated LED. In addition, an estimated temperature of the activated LED can be compared, in some instances, to the temperature measured by the temperature sensor 438 to determine a difference between a bulk temperature and the temperature of the activated LED. The processor 420 can accordingly use this information to obtain more accurate and precise measurement values for the one or more monitored parameters. The relationships between an LED forward voltage, centroid wavelength, power output, junction temperature, duty cycle, and current are known to a skilled artisan and thus not described in herein. Example algorithms for determining measurement values can be

found in U.S. Pat. No. 6,157,850 (the '850 patent). The disclosure relating to determination of measurements from sensor data in the disclosure of the '850 patent is incorporated in its entirety by reference herein.

[0089] The output signal from the analog mux 436 can, in some embodiments, be used to control the currents i_1 and i_2 to vary the centroid wavelength (for example, by ± 15 nm from a rated centroid wavelength) of an LED of the light source 424 so that the LED can irradiate tissue at different wavelengths of light.

[0090] In yet another example, the processor 420 can control a bulk temperature or a temperature near an LED of the light source 434 using the heat pump 440. The heat pump 440 can be used to maintain a constant temperature or achieve some desired temperature. Moreover, in some embodiments, the processor 420 can use the heat pump 442 to control a temperature near one or more photodiodes used to detect the light irradiated by an activated LED of the light source 434.

[0091] In some embodiments, for example in embodiments directed to implementing high speed spectral sweep analysis discussed in further detail below, the emitter 634 (e.g., LED) temperature, forward voltage and/or current are intentionally changed in order to change the wavelengths of light emitted by the emitters 434. In an embodiment, a temperature, forward voltage and/or current of one or more emitters 434 is intentionally cycled in order to predictably change the wavelength of light emitted by the emitters 434. For example, once the emitters 434 reach an initial known operational state, the temperature, forward voltage, and/or current of an emitter 434 can be intentionally changed to create a different operational state. This process can continue, cycling or sweeping the emitters 434 through different operational states. This process can be repeated during the course of measurement in order to make the emitters 434 irradiate light at different wavelengths and thus enabling collection of information about the sample tissue at different wavelengths. In some embodiments, temperatures are swept between about 15 degrees Celsius and about 45 degrees Celsius. In an embodiment, temperatures are swept between about 20 degrees Celsius and about 40 degrees Celsius. In some embodiments, the temperature of the emitters 434 is varied by altering the forward voltage, the drive current, the duty-cycle of the emitters 434, or a combination of the above. In some embodiments the emitter 434 temperature is swept in an uncontrolled way by allowing the temperature to heat up naturally through the process of driving current through the LED.

[0092] By varying emitter 434 temperatures and thereby causing the emitter 634 to sweep through a range of wavelengths, greater absorption information can be determined. For example, the information gained from sweeping the wavelengths can be used to characterize a slope of the absorption curve. This information can be used to obtain more accurate results. Emitter 434 temperature changes can also force emitted wavelengths to a predetermined, known centroid or interpolation point, reducing processing requirements and increasing accuracy. Additionally or alternatively, the act of sweeping emitter 434 temperatures effectively creates additional wavelengths without affecting path length or requiring a large number of emitters 434. These additional wavelengths can be used in the calculation of the physiological parameters. SLED wavelengths can also be deconvolved such that the full wavelength information from the

SLED spectrum can be used rather than just a single average point (i.e., the SLED centroid wavelength), which will provide higher spectral resolution data. The deconvolution can be performed by characterizing the full spectral changes of a SLED at the drive current, duty cycle, and temperature that the SLED will be operated at and using this a priori spectral information to extract the full wavelength information during runtime.

[0093] FIG. 5 illustrates generally a detection profile of an indium gallium arsenide (InGaAs) photodetector 306 based on wavelength and temperature. For certain wavelengths, for example around about 1500 nm, the detection profile is flat and detector 306 measurements are relatively unaffected by temperature shifts. However, for longer wavelengths beyond about 1520 nm, significant signal degradation can occur with temperature shifts. Thus, controlling the temperature of the detector 306, particularly for certain wavelengths, can stabilize DC measurements to improve accuracy.

[0094] Attention is now directed to embodiments of the present disclosure that are configured to perform high speed spectral sweep analysis to non-invasively predict, among other analytes, glucose in tissue. A spectrometer is disclosed that spans (or sweeps) specific wavelength regions and collects intensity data of light through tissue. The measured light intensity through the tissue (I_T) is divided by intensity fluctuations from the light source (I_0) to derive the sample tissue bulk absorbance (Abs_T). The relationship between these parameters can be expressed as:

$$\text{Transmittance} = \frac{I_T}{I_0} = 10^{-Abs_T} \quad (1)$$

$$\text{Bulk Absorbance} = Abs_T = \text{LOG}_{10} \frac{I_0}{I_T} \quad (2)$$

[0095] Using empirical clinical data, an inverse model of the collected data at different blood glucose values can be created and used to predict glucose (or other analyte) values based on the measured tissue bulk absorbance (Abs_T) and other parameters collected by the high speed data collection system. Some other examples of parameters that can be used in the development of an inverse model include but are not limited to various measured temperatures (LED, tissue, ambient, photodiode, beam splitter, etc.) and absorbance of various reference materials measured real time. Such a model may be referred to as a "predictive calibration model." For illustration purposes, the present disclosure describes embodiments of systems, devices, and methods employing high speed spectral sweep analysis applied to a direct current (DC) measurement of glucose in tissue. However, one skilled in the art will recognize that the systems, devices, and methods disclosed herein can also be applied to alternating current (AC) measurements of glucose in tissue, as well as to other blood constituents.

[0096] The disclosed systems, devices and methods for high speed spectral sweep analysis to non-invasively predict, among other things, glucose in tissue rely on careful control of the environment in which the data is collected. Informative spectral data can be obtained during the sweeping of specific wavelength regions of sample tissue. The spectral measurements are sensitive to sources of error, such as for example, fluctuations in power, temperature, and wavelength, among other things. Accordingly, systems,

devices and methods disclosed herein are used to monitor, control and/or adjust for, among other things, variations in emitter light source, emitter temperature, tissue temperature, and photodetector temperature to reduce or eliminate distortion in the collected spectral information that is reflective of blood constituents, such as, for example, glucose. Additionally, the disclosed high speed data collection systems, devices and methods are used to collect a larger quantity of spectral information than can be collected using lower speed, averaged data collection approaches. Tissue sample size is also controlled to reduce distortion and to increase the quantity of useful spectral information collected. Similarly, fixed distances between emitter and detector are implemented to secure useful spectral information. Accurate measurement and/or control of emitter temperature, tissue sample temperature, and photodetector temperature are also disclosed herein, again, to help secure the collection of valuable and useful spectral information reflective of blood constituents, such as glucose.

[0097] FIG. 6 is a block diagram illustrating an embodiment of a data collection system 600 that can be configured to perform high speed spectral sweep analysis disclosed herein. In certain embodiments, the data collection system 600 non-invasively measures a blood analyte, such as, by way of non-limiting example, glucose. The data collection system 600 includes a sensor 601 configured to irradiate visible and/or infra-red light to a sample tissue 602 of a patient at a measurement site and then detect the optical radiation that is attenuated by the sample tissue 602. In some embodiments, optical radiation that is reflected by the sample tissue 602 can be detected. The sensor 601 includes one or more emitters 604 that generate the optical radiation, or light source 630. A thermal controller 620, which may also be referred to as a temperature regulation component, can be in thermal contact with the emitter 604 to monitor and/or control the thermal properties of the emitter 604 during operation. The thermal controller 620 can include a temperature sensor, such as for example, a thermistor, to measure the temperature of the emitter 604 during operation. The thermal controller 620 can also include a thermoelectric cooler (TEC), such as for example, a Peltier device, to lower the temperature of the emitter 604. However, one skilled in the art will recognize that the TEC can be electrically reversed to increase the temperature of the emitter. Therefore, through the use of an adequate electrical current, the emitter temperature can be fully and well controlled in a certain or desired range. A heat sink can be thermally coupled to a "hot end" of the TEC to dissipate heat. Thus, the thermal controller 620 serves as a circuitry based temperature alteration device. The thermal controller 620 communicates with a high speed data collection board/front end interface 608 to transmit temperature information of the emitter 604 to the high speed data collection board/front end interface 608. The temperature information can be transmitted to the signal processor 610, and the signal processor 610 can use the emitter 604 temperature information to adjust signal processing parameters to compensate for temperature variations of the emitter 604. According to an embodiment, the signal processor 610 is connected to the thermal controller 620 and therefore can transmit a thermal control signal 640 to the thermal controller 620 to regulate the temperature of the emitter 604 during operation. In some embodiments, regulation and control of the thermal controller 620 is performed by the high speed data collection

board/front end interface 608. In other embodiments, the signal processor and/or the high speed data collection board/front end interface 608 can control the thermal controller 620. Regulation of emitter 604 temperature can be used to vary (or sweep) the wavelength of the light source 630 at a desired rate or shape.

[0098] Measurement of the emitter light source 630 within the emitter electronics package is performed to account for power changes to the optical radiation emitted by the emitter 604. Methods to obtain accurate measurement of the emitter light source 630 (I_0), including fluctuations thereto, are disclosed to help derive a sample tissue bulk absorbance (Abs_T) that is useful in predicting, for example, the glucose level of the sampled tissue. The light source 630 emitted from the emitter 604 is directed to a splitter 622. The splitter 622 splits the emitted light source 630 into a plurality of beams. For the purpose of this disclosure, it splits the light into a first beam 632, into a second beam 634 and into a third beam 638. The first beam 632 comprises a portion of the light source 630 that is emitted from the emitter 604 and used to irradiate the sample tissue 602 of the patient. The second beam 634 comprises a fractional portion of the light source 630 that is directed to a detector 624 configured to measure the fractional portion of the light source 630 for use in determining intensity fluctuations from the light source (I_0), which in turn, is used to derive the bulk absorbance (Abs_T) of the sample tissue 602. The third beam 638 comprises a fractional portion of the light source 630 that is directed to a reference absorption material 648 and to a detector 628 configured to measure the fractional portion of the light source 630 for use in determining spectral content of light source (fret), which in turn, is used to derive the bulk absorbance (Abs_T) of the sample tissue 602. The reference absorption material 648 shall have a known absorption profile. The ideal reference absorption material 648 shall be stable over time such that it does not shift with wavelength or with absorption. One example of a reference absorption material is water sealed in a cuvette. The advantage of water is that it has a similar absorption profile to the tissue sample site which gives it an advantage to be able to capture real-time wavelength changes. Another example of a reference absorption material 648 is didymium oxide glass. Other materials, including other rare earth oxide glass materials may be used as the reference absorption material 648. The reference absorption material 648 may also comprise a plastic such as polystyrene, polycarbonate, or an acrylic.

[0099] In some embodiments, the emitter light source detector 624 is optically coupled to the emitter 604 to help prevent dissipation of, or interference from other light sources with, the second beam 634. In an embodiment, optical grade polytetrafluoroethylene (PTFE), also known by the brand name Teflon™, is used to mix, attenuate, and optically couple the emitter light source detector 624 to the emitter 604. Optical grade PTFE possesses optical properties that remain constant over a wide range of wavelengths, spanning from the ultraviolet to the near infrared wavelengths. When transmitting optical radiation in this range of wavelengths, the relation of PTFE's regular transmittance to diffuse transmittance is negligible, thereby serving as an optical coupler that can transmit optical radiation with minimal loss, distortion, or interference. Thus, optical grade PTFE is a suitable material to couple the fractional portion of the light source 630 from the emitter 604 to the emitter

light source detector **624**, which may be optically shielded to prevent losses or distortion.

[0100] In an embodiment the emitter light source detector **624**, such as a photodiode, is optically coupled to the emitter **604** to measure the light generated by the emitter **604**. The emitter light source photodetector **624** is configured to sample a predetermined fraction of the light that will enter the sample tissue. The fractional portion of the emitted light that is measured by the emitter light source photodetector **624** is a complete, scaled representation of the light delivered to the sample tissue **602**, having a power and wavelength distribution, such that the ratio of

$$\frac{I_T}{I_0}$$

should not change with fluctuations in light source power due to temperature, drive current, duty cycle, or the like. The emitter light source photodetector **628** is configured to sample a predetermined fraction of the irradiated light that is directed to a reference spectral sample **648**. The fractional portion of the light that is measured by the photodetector **628** is an attenuated portion of the light delivered to the sample tissue **602**, having power and wavelength distribution attenuated by the reference sample **648** such that the ratio of

$$\frac{I_{REF}}{I_0}$$

should take into account the spectral information caused by the intentional changes in source temperature, drive current, duty cycle, or the like. In another embodiment there can be more than one reference sample **648** and photodetector reference channels **628**. A specific example would be one reference sample that is a pure water filled cuvette and another reference sample that is a cuvette filled with water and a predetermined concentration of glucose.

[0101] Accordingly, the measured emitter light source (I_0) **650** and the measured light intensity transmitted through the tissue (I_T) **652** and **653** should change in the same proportion as do the power or wavelength fluctuations of the emitted optical radiation **630**. Similarly, the emitted light source (I_{ref}) **658** should also change based on the spectral response of the filter **648**. In an embodiment, the first beam **632** comprises ninety-nine percent of the emitted light source **630**, and the second beam **634** and the third beam **638** comprise one percent of the emitted light source **630**. Of course, a skilled artisan will appreciate that other percentages may be used without departing from the teaching of the present disclosure.

[0102] The sample tissue **602** may also be in thermal communication with a thermal controller **626** to monitor and/or regulate the temperature of the sample tissue **602** during measurement. As described above, the thermal controller can comprise a temperature sensor, a TEC, and a heat sink. As illustrated in FIG. 6, the thermal controller **626** is connected to the high speed data collection board/front end interface **608** which is configured to receive signals from the various components of the sensor **601**, process (or pre-process) the signals, and transmit the processed (or pre-processed) signals to the signal processor **610**. The signal

processor **610** can use sample tissue **602** temperature information to adjust signal processing parameters to compensate for temperature variations in the sample tissue **602**. In some embodiments, the signal processor **610** is connected to the thermal controller **626** and therefore can transmit a thermal control signal **642** to the thermal controller **626** to regulate the temperature of the sample tissue **602** during operation. In other embodiments, control of the thermal controller is performed by the high speed data collection board/front end interface **608**. In other embodiments, the signal processor and/or the high speed data collection board/front end interface **608** can control the thermal controller **626**. In another embodiment the reference sample **648** can have an independent thermal controller (not shown) to control the reference sample to a fixed temperature or to match the temperature of the sample tissue **602**. The sensor can also be designed in a way to couple the reference material and the sample tissue such that they have the same or similar temperatures.

[0103] The first beam **632**, directed at the sample tissue **602**, is attenuated by the sample tissue **602**. The attenuated light **636** and **637** are detected by multiple tissue light detectors **606** and **607** which measure the light intensity through the tissue (I_{T1} and I_{T2}), corresponding to the attenuated light **636** and **637**. In some embodiments, the tissue light detectors **606** and **607** are placed at different locations in order to create different tissue paths that the light **636** and **637** pass through. In some embodiments, the tissue light detector **606** or **607** measures light that is reflected from the sample tissue **602**. The tissue light detectors **606** and **607** are connected to the high speed data collection board/front end interface **608** which is configured to receive signals from the various components of the sensor **601**, process (or pre-process) the signals, and transmit the processed (or pre-processed) signals to the signal processor **610**.

[0104] The high speed data collection board/front end interface **608** is configured to support high speed spectral sweep analysis for non-invasive measurement and prediction of blood constituents, such as, for example, glucose. According to an implementation, a fully differential path is implemented using, for example, a transimpedance amplifier to reduce near field crosstalk and to provide immunity from noise. The high speed data collection board/front-end interface **608** is simplified (as compared to other embodiments previously described) by removing certain stages included in other embodiments of the front end interface. For example, a programmable gain amplifier (PGA) stage can be eliminated, a high pass filter stage can be eliminated, and a single-ended to differential-ended stage can be eliminated. A field programmable gate array (or similar type of device) can be used to implement a multi-stream, high-throughput serial bus to support the high speed data collection to implement the methods of high speed spectral sweep analysis disclosed herein. Moreover, high accuracy, successive approximation register ADCs can be used (as opposed to other types of ADCs) to reduce or to substantially eliminate ringing effects during spectral sweeping. A person skilled in the art may recognize that the herein described ringing is frequently observed on data processed by digital filters such as, for example, a FIR filter.

[0105] The data collection system **600** also includes a monitor **609** comprising the signal processor **610**, a user interface connected to the signal processor, a storage device **614** and a network interface device **616**, which are connected to the signal processor **610**. As shown in FIG. 6, the

monitor 609 can include the signal processor 610 and a user interface, such as a display 612. The monitor 609 can also include optional outputs alone or in combination with the display 612, such as a storage device 614 and a network interface 616. In an embodiment, the signal processor 610 includes processing logic that determines measurements for desired analytes, such as glucose, based on the signals received from the detectors 606, 624. The signal processor 610 can be implemented using one or more microprocessors or subprocessors (e.g., cores), digital signal processors, application specific integrated circuits (ASICs), field programmable gate arrays (FPGAs), combinations of the same, and the like.

[0106] Wavelength sweeping can be performed, among other methods, by controlling and/or changing the temperature of the emitter 604, by controlling and/or changing the current delivered to the emitter 604, by controlling and/or changing the duty cycle of the signal that drives the emitter 604, and in some instances, by allowing the temperature of the emitter 604 to fluctuate freely. Some embodiments of the disclosed high speed spectral sweep analysis systems, devices, and methods include the use of at least one emitter 604 capable of emitting wavelengths that are useful in detecting blood constituents, such as, for example, glucose. The emitter 604 serves as the source of optical radiation transmitted toward the measurement site. The emitter 604 can include one or more sources of optical radiation, such as light-emitting diodes (“LEDs”) including, by way of non-limiting example, top-emitting LEDs, side-emitting LEDs, super-luminescent LEDs (“SLEDs”), laser diodes, incandescent bulbs with appropriate frequency-selective filters, combinations of the same, or the like. In an embodiment, the emitter 604 includes sets of optical sources 604 that are capable of emitting visible and near-infrared optical radiation. Each emitter 604 is manufactured to emit optical radiation at a specific centroid wavelength, within certain tolerances. However, in practical implementation the wavelength emitted by an emitter 604 can fluctuate based on, for example, variations in the temperature of the emitter 604, the amount of current supplied to the emitter 604, and the duty cycle (i.e., the percentage of time within a period that a signal is active) of the signal that drives the emitter 604. By controlling these parameters, among others, the systems, devices and methods disclosed herein can cause the emitter 604 to sweep through a range of wavelengths to support collection of valuable spectral information.

[0107] Wavelength sweeping can be implemented by controlling the temperature of the emitter(s) 604 to intentionally vary the wavelength of optical radiation 630 emitted from the emitter(s) 604. In an embodiment, the thermal controller 620 comprising a thermoelectric cooler can be used to help perform such temperature control. The principle of thermoelectric cooling, based on the Peltier effect (also known generally as the thermoelectric effect), creates heat flux at a junction between two different types of materials. A Peltier device, which may function as a cooler, a heater, or a thermoelectric heat pump, is a solid state device configured to transfer thermal energy from one side of the device to the other side of the device, with the consumption of electrical energy, depending on the direction of the applied current. A Peltier device may also be referred to as a Peltier heat pump, a solid state refrigerator, or a thermoelectric cooler (TEC). A Peltier device can be used for heating, cooling or as a temperature controller that both heats and cools. However,

the most commonly used application of Peltier devices is for cooling. Advantages of Peltier devices include the ability to control temperatures to within fractions of a degree, controllability by varying input voltage or current, lack of moving parts, lack of circulating liquid (e.g., a refrigerant), long life, high reliability, flexible shape and form factors, and small size. In operation as a thermoelectric cooler a voltage is applied across the device which leads to a difference in temperature between the two sides of the TEC. As DC current flows through the device, heat is transferred from one side of the device to the other. Thus one side becomes cooler while the other side becomes hotter. The hotter side of the device can be attached to a heat sink to dissipate some of the generated heat and maintain the “hot side” of the device at a desired temperature, such as, for example, ambient temperature. The cooler side of the device can be maintained below ambient temperature.

[0108] Variation of the drive current 654 delivered to an emitter 604 can also cause the emitter 604 to sweep through a range of wavelengths. The signal processor 610 can control the current controller, or driver 611, to vary the current delivered to the emitter 604 in a manner such that the emitter 604 sweeps through a desired range of wavelengths, by way of non-limiting example, by changing the current in a linear fashion or other types of waveforms. In some embodiments the signal processor 610 can vary the duty cycle of the signal 654 that drives the emitter 604 in a manner to cause the light source 604 to sweep through a desired range of wavelengths. In some embodiments the emitter 604 is a SLED. The emitter 604 may also be allowed to sweep through a range of wavelengths based on the naturally-occurring changes in temperature of the emitter 604. Additionally, control of the emitter’s 604 natural heating and cooling times can be modified by changing heat sinking properties of the electronics package in which the emitter 604 is implemented.

[0109] In an embodiment configured to predict glucose levels, a wavelength range from approximately 1300 nm to approximately 1650 nm is used. This wavelength range can be spanned, or swept, by selecting a number of distinct wavelengths to separate glucose from water. In an embodiment, three distinct wavelengths are selected, and in an embodiment four distinct wavelengths are selected. One skilled in the art will appreciate that different numbers of distinct wavelengths may be used without departing from the teaching of the present disclosure. In an embodiment, the distinct wavelengths can be used to measure and correct for fluctuations of temperature in the sample tissue 602 being measured. In an embodiment configured to predict glucose levels, a wavelength range of approximately 1330 nm to approximately 1400 nm may be used. This wavelength range can be spanned by a single emitter 604, such as, for example, a super-luminescent LED. Additionally, this wavelength range can be used to correct for scattering and temperature fluctuations in the tissue being measured. In an embodiment, a wavelength range of approximately 500 nm to approximately 1750 nm may be used to measure constituents of blood, such as, by way of non-limiting example, various hemoglobin constituents, cholesterol, lipids, and the like.

[0110] Systems, devices and methods directed at collecting data at high speeds (as compared to relatively lower speed, averaged data collection methods frequently used in pulse oximetry systems) are used to capture spectral information that is useful in predicting, for example, glucose

levels in tissue. Emitters **604** are typically modulated at a duty cycle of approximately ten percent, though it is understood that various other duty cycles can be used. During the time that the emitter **604** is active (i.e., emitting light), the junction temperature of the emitter **604** increases. The temperature increase causes a power drop and a red shift of wavelength, which may be referred to as a “high speed crown.” A spectral sweep occurs during the high speed crown which provides valuable spectral information that is useful in determining constituents in tissue, such as for example, glucose. A skilled artisan will appreciate that “red shift” means an increase in the wavelength, while a “blue shift” means a decrease in the wavelength of emitted light.

[0111] A challenge in the signal processing of high speed crowns is that noise in the form of ringing can be present. Such ringing-based noise can prevent successful extraction of the valuable spectral information contained in the high speed crown. The ringing is an inherent property of certain analog-to-digital converters (ADCs) commonly used in processing the collected high speed crown data, such as, for example, sigma-delta ADCs and oversampling type ADCs, to name a few. FIG. 7 illustrates examples of noise caused by ringing. As shown, the effect of ringing distorts the spectral information that is useful in determining constituents in blood.

[0112] It is possible to substantially reduce or effectively eliminate this ringing phenomenon by using high-accuracy, successive approximation register (SAR) ADCs to acquire raw high speed crown data. FIG. 8 illustrates examples of high speed crowns acquired by a high accuracy SAR ADC. As shown, the signals processed using a high-accuracy SAR ADC eliminate the distortion caused by ringing, thereby making it possible to obtain the valuable spectral information in the high speed crowns for use in determining constituents in blood, such as glucose. High speed crowns of a given LED can be used to calculate a tissue absorption segment over the spectral sweep that occurs in the crown by using equation 2 above. The tissue absorption segments can be combined from different crowns into tissue absorption bands. An example of tissue absorption bands for three SLEDs is provided in FIG. 9. Further deconvolution of multiple LED spectra can be performed in order to capture a full wavelength, high resolution tissue absorption profile by using a priori information of an LED's full spectrum characterized at different currents, duty cycles and temperatures.

[0113] In the present disclosure, the size of the sample tissue **602** is also controlled to reduce distortion and to increase the quantity of useful spectral information collected. Similarly, a fixed distance between emitter **604** and detector **606** is implemented to secure useful spectral information. According to certain embodiments for measuring glucose, the sample tissue **602** contains interstitial fluid which can have varying amounts of glucose to be measured.

[0114] Interstitial fluid comprises a thin layer of fluid that surrounds the cells of a body. In humans, interstitial fluid makes up approximately forty percent of the water in the body and thus accounts for approximately one-sixth of a human's body weight. Interstitial fluid serves as a source of fuel for cells, comprising glucose, salt, fatty acids, and minerals including calcium, magnesium, and potassium. Blood capillaries provide the nutrients to the interstitial fluid. Accordingly, levels of a blood constituent, such as glucose, in interstitial fluid can reflect (with an acceptable

degree of accuracy) levels of that constituent in blood. In certain embodiments of the present disclosure, skin is used as the sample tissue **602** on which measurements are taken.

[0115] To reduce variability of measurements, thickness of the sample tissue **602** is controlled in a manner such that the distance between the emitter **604** and the detectors **606** and **607** is fixed. In some embodiments, the thickness of the sample tissue **602** can be controlled to have different distances between the emitter **604** and the different detectors **606** and **607**. In some embodiments, in order to have the sample tissue **602** fit within the fixed distance between the emitter **604** and the detectors **606** and **607** without stretching or deforming the tissue in an undesirable way an application of a coupling agent, such as, by way of non-limiting example, a perfluorinated liquid. In some embodiments, the webbing between a subject's thumb and index finger is used as the sample tissue **602**. In some embodiments, a skin-fold pinch, which may be collected anywhere on the patient's body, comprises the sample tissue **602**. A skilled artisan will appreciate that many other portions of a subject's body may serve as sources of sample tissue **602** without departing from the teachings of the present disclosure. A skilled artisan will also appreciate that many more detectors placed at different locations can be used without departing from the teachings of the present disclosure.

[0116] Referring again to FIG. 6, in some embodiments, the temperature of the sample tissue **602** is controlled and/or compensated for during non-invasive measurement. Water absorption of optical radiation increases significantly at a wavelength of 1450 nm. However, as the temperature of water increases, the absorption wavelength decreases (i.e., blue shifts). As discussed above, to predict glucose levels, a wavelength range from approximately 1300 nm to approximately 1650 nm may be used. Thus, the absorbance of interstitial fluid (comprising mostly of water) in the sample tissue **602** drops as its temperature increases. To compensate for variability in tissue temperature a thermometer (or other temperature sensor known in the art) may be used to determine the sample tissue **602** temperature during measurement by the sensor **601**. In an embodiment the temperature sensor is included in the thermal controller **626**. Additionally, temperature modeling may be used to determine average sample tissue **602** temperatures or a distribution of sample tissue temperatures through the sample tissue volume. The temperature information can be used to adjust for changes in absorbance of the interstitial fluid to help determine a more accurate measurement of the sample tissue **602** bulk absorbance. In other embodiments, the thermal controller **626** which may comprise passive or active temperature control structures, may be used to control the sample tissue **602** temperature. For example, a TEC coupled to a heat sink can be used to regulate the temperature of the sample tissue **602**. In some instances, the sample tissue **602** temperature can be regulated to within 1 degree Celsius. In some embodiments, a temperature sensor is configured to measure the sample tissue **602** temperature during sensor **601** operation. The predictive calibration model can be based on variable tissue temperature (as measured by the sample tissue **602** temperature sensor) to compensate for water absorbance changes due to temperature fluctuations.

[0117] Changes in temperature of detectors **606**, **607**, **624**, **628** (e.g., photodiodes) can degrade the integrity of signals used to measure blood constituents. The present disclosure provides systems, devices and methods for controlling and/

or compensating for fluctuations of temperature of detectors **606**, **607**, **624**, **628** employed during non-invasive sample tissue measurements. In some embodiments, thermistors (or other temperature sensors) can be coupled to the photodetectors **606**, **607**, **624**, **628** to monitor and/or correct for photodiode temperature variation. In some embodiments, a thermal controller **620**, **626**, comprising a temperature sensor, a thermoelectric cooler, and a heat sink, may be used to regulate photodiode **606**, **607**, **624**, **628** temperature(s) to within one-tenth or less of a degree Celsius.

[0118] In an embodiment, a TEC (not shown) is provided to control the temperature of the photodetectors **606**, **607**, **624**, **628**. In an embodiment, an integrating sphere having port holes through which emitted light **630** can be transmitted can be used as the beam splitter. The integrating sphere can be coated with a diffuse material such as Spectralon, optical PTFE or diffuse gold to improve the mixing of the light. Other diffuse coatings that have a flat spectral response can be used as well. The emitted light **630** is directed through a first portal into the integrating sphere. The integrating sphere acting as the beam splitter splits the emitted light **630**, allowing a fraction of the emitted light **634** to transmit into an optical coupler that is coupled directly to the emitter light source photodetector **624**. The emitter light source photodetector **624** is optically shielded to avoid dissipation of, and interference with, the fractional portion of the emitted light **634** that is directed to the photodetector **624**. The emitter light source photodetector **624** is also thermally shielded to minimize susceptibility to thermal fluctuations which might affect the accuracy of the photodetector's **624** measurements. Similarly, a fraction of the emitted light is directed to the detector **628** which is coupled to a reference absorption material **648**. The remainder of the emitted light **632** is directed to the sample tissue **602** through a second portal of the integrating sphere **660**. In an embodiment, the beam splitter **622** passes 99% of the emitted light **630** to the sample tissue **602**, and it passes 1% of the emitted light **630** to the emitter light source photodetectors **624**, **628**. A skilled artisan will understand and appreciate that other proportions of the emitted light can be split between the emitted light source photodetectors **624**, **628** and the sample tissue **602**.

[0119] In an embodiment, rather than controlling the thickness of the sample tissue **602** the absorbance of the Sample Tissue **1402** can be controlled. FIG. 14 illustrates a possible way to control absorbance of the Sample Tissue **1402**. Using an actuator to control the distance between the Emitter **1404** and the tissue Detector **1206** the Sample Tissue **1402** thickness can be adjusted. As the actuator closes the absorbance of the Sample Tissue **1402** will decrease. In order to make the Sample Tissue thickness increase negative pressure can be applied to both sides of the Sample Tissue such that the interface at both sides is pulled into a tissue receptacle **1403** and **1405**. As the actuator opens the Sample Tissue thickness will increase and pull water into the tissue volume and therefore the absorbance will increase. By using the actuator with the vacuum the system can adjust to hold the water volume (or absorbance) in the Sample Tissue constant over time and from measurement to measurement. This can allow for improved placement repeatability and a more controlled data set when generating a calibration curve. The actuator control can also be used to change the thickness of the tissue in a controlled way in order to collect optical data at multiple Sample Tissue thicknesses.

[0120] FIG. 9 illustrates results from an implementation of the disclosed high speed spectral sweep analysis system which was implemented to measure sample solutions (representing sample tissue **602**) of having varying concentrations of glucose in water. A thermal controller **620**, controlled by the high speed data collection board **606**, was thermally coupled to SLED emitters **604** to vary the temperature of the SLED emitters **604** during operation. A second thermal controller **626**, controlled by the high speed data collection board **606**, was thermally coupled to the sample solution (representing sample tissue **602**) to maintain the sample solution's to a known temperature e.g., at 24° C. A temperature sensor was connected to the photodetector **606** measuring light attenuated by the sample solution to monitor temperature fluctuations of the detector **606**. Control of the temperature of the photodetectors **606**, **624** was performed by placing the entire sensor **601** including the photodetectors **606**, **624** in an environmental chamber (not shown) configured to maintain a controlled ambient temperature of e.g. 24° C. The measured light intensity through the tissue (I_T) was measured by the photodetector **606**, while the light intensity from the SLED emitters **604** (I_0) was measured by the photodetector **624**. The distance between the emitter **604** and the detector **606** was known and fixed. The sample solutions were randomized to have differing concentrations of glucose ranging from 0 to 600 mg/dL each day, and the system operated for four consecutive days (after three days used for training). Based on the provided measurements, the signal processor **606** determined the bulk absorbance (Abs_T) of the sample solution.

[0121] As illustrated in FIG. 9, the three SLED emitters **604** discontinuously spanned a wavelength range between 1520 nm and 1615 nm. By varying driver current to, and temperature of, the SLED emitters, the emitted wavelengths were varied, thereby providing a sweep of wavelengths to provide spectral information to be analyzed by the disclosed system. In particular, a first emitter **604** configured to emit light at a wavelength of 1540 nm swept an approximate range of wavelengths between 1520 nm and 1550 nm. A second emitter **604** configured to emit light at a wavelength of 1585 nm swept an approximate range of wavelengths between 1576 nm and 1582 nm. A third emitter **604** configured to emit light at a wavelength of 1605 nm swept an approximate range of wavelengths between 1588 nm and 1615 nm. The sweeps were implemented by adjusting the drive current for each emitter to three discrete levels (700 mA, 450 mA, and 200 mA), and by adjusting the temperature of each emitter **604** to three discrete temperatures (24° C., 30° C., and 36° C.), yielding nine separate emitted wavelengths for each of the three emitters, comprising a total of twenty-seven measurements. The values plotted in FIG. 9 reflect the derived bulk absorbance (Abs_T) for each of the twenty-seven measurements. Below the plotted values is a curve **1202** representing the absolute water spectrum obtained by use of a benchtop spectrophotometer system, generated for purposes of comparison. The plotted values, generated by the disclosed high speed spectral sweep analysis correlate with the curve **1202**, demonstrating validity of the disclosed high speed spectral sweep analysis systems, devices and methods for determining bulk absorbance of a sample tissue.

[0122] As previously described with respect to FIG. 8, signals processed using a high-accuracy SAR ADC eliminate the distortion caused by ringing, thereby making it

possible to obtain the valuable spectral information in the high speed crowns for use in determining constituents in blood, such as glucose. High speed crowns of a given LED can be used to calculate a tissue absorption segment over the spectral sweep that occurs in the crown by using equation 2 above. The tissue absorption segments can be combined from different crowns into tissue absorption bands. An example of tissue absorption bands for three SLEDs is provided in FIG. 9. Further deconvolution of multiple LED spectra can be performed in order to capture a full wavelength, high resolution tissue absorption profile by using a priori information of an LED's full spectrum characterized at different currents, duty cycles and temperatures.

[0123] FIG. 10A illustrates the averaged wavelengths of overlapped data (i.e., data collected on multiple days having differing concentrations of glucose ranging from 0 to 600 mg/dL) corresponding to the discontinuously swept wavelength ranges between 1520 nm and 1615 nm of FIG. 9. In particular, the overlapped data reflects measurements of the different sample solutions (representing sample tissue 602) having varying concentrations of glucose. The graphed data of FIG. 10A exhibit sensitivity to glucose as the detected concentrations of glucose correspond to the various concentrations of glucose of the sample solutions. FIGS. 10B-D present enlarged portions of the data presented in FIG. 10A. In particular, FIG. 10B illustrates an enlarged portion of the graph depicted in FIG. 10A, centered around the wavelength of 1540 nm; FIG. 10C illustrates an enlarged portion of the graph depicted in FIG. 10A, centered around the wavelength of 1585 nm; and FIG. 10D illustrates an enlarged portion of the graph depicted in FIG. 10A, centered around the wavelength of 1605 nm. As can be seen more clearly in the enlarged portions depicted in FIGS. 10B-D, the plotted lines illustrate sensitivity to glucose. FIG. 11 illustrates correlation between the reference concentration of glucose in solution (on the x-axis) and the predicted concentration as determined by the disclosed high speed spectral sweep analysis systems, devices and methods (on the y-axis). The average root mean square deviation is 14 mg/dL, corresponding to acceptable measurement accuracy levels for analytes like glucose.

[0124] FIG. 13 is a cross-sectional view of an embodiment described in FIG. 12 where the two photodiode channels are oriented transverse to the sensor head and are placed on sample tissue opposite the emitter(s) 1301 and at two distinct distances d_1 1321 and d_2 1322. The detectors 1311 and 1312 receive signals I_{T1} and I_{T2} respectively. The tissue sample can be separated into multiple compartments. A simple compartment model includes a layer of epidermis on top and bottom at the outermost surfaces which are in contact with the emitter(s) 1301 and detectors 1311 and 1312. For the shorter distance d_2 the tissue can be compressed such that the two layers of skin are in contact and the epidermis and dermis are compressed such that just a small amount of extra cellular fluid occupies the optical path. For the larger distance d_1 the tissue spacing allows interstitial fluid, the extra cellular fluid to fill the gap within the optical path. The two different signals measured on the tissue I_{T1} and I_{T2} allow for both data streams to be processed in fitting for glucose. Within the tissue the glucose resides predominantly in the interstitial fluid, so the signal I_{T1} will contain the predominant glucose signal in contrast I_{T2} will have a minimal glucose signal since the interstitial fluid has all been pushed out due to compression of the tissue. Such detector

geometry can be used for measurement of glucose as well as tissue hydration and other tissue constituents. Given the difference in pathlengths the following equations can be used to formalize the measured signal. As with pulse oximetry the difference in the two pathlengths can be used to describe an AC signal and a DC signal and ratios of the various signals can be taken to calibrate out any effect of the instrument response of the system.

[0125] Another embodiment of a differential pathlength sensor could be to use a system with a minimum of one photodiode such as the sensor depicted in FIG. 2. As described previously the sensor includes a depth stop 208 which serves to define a fixed distance between the emitter shell 204 and the detector shell 206, thereby defining a known path length between emitter(s) and detector(s). The sensor could be designed such that the depth stop is mechanically adjustable to multiple known distances such that using the same emitter(s) and detector(s) paired one can take measurements while actively changing the path length of the tissue between the emitter(s) and detector(s). One advantage to this embodiment would be that the same detector(s) would be used for all the data acquired, which could be advantages if there were photodiode properties that could change from one photodiode to another such as the spectral responsivity of the photodiode. A disadvantage is that the data must be collected at different points in time and therefore the tissue could be changing in time.

[0126] Although the preceding paragraphs describe specific embodiments where the components of the disclosed systems and devices can be included in one of the monitor 110, 309, or 609, the sensor 120, 301, 400, or 601, and the cable 130, the disclosure is not intended to be limited thereby. Rather, a skilled artisan will recognize from the disclosure herein that the components can individually be placed anywhere along the monitoring path in the monitor 110, 309, or 609, in the sensor 120, 301, 400, or 601, or in the cable 130, or in connectors associated with any of the foregoing, so long as the components may continue to perform their desired functionality. Further, one or more of the components may not be included in the system 400 in some implementations. For instance, the system 400 may not include one or both of the temperature sensor 438 and the heat pump 440.

[0127] Embodiments have been described in connection with the accompanying drawings. However, it should be understood that the figures are not drawn to scale. Distances, angles, etc. are merely illustrative and do not necessarily bear an exact relationship to actual dimensions and layout of the devices illustrated. In addition, the foregoing embodiments have been described at a level of detail to allow one of ordinary skill in the art to make and use the devices, systems, methods, etc. described herein. A wide variety of variation is possible. Components, elements, and/or steps can be altered, added, removed, or rearranged. While certain embodiments have been explicitly described, other embodiments will become apparent to those of ordinary skill in the art based on this disclosure.

[0128] Conditional language used herein, such as, among others, "can," "could," "might," "may," "e.g.," and the like, unless specifically stated otherwise, or otherwise understood within the context as used, is generally intended to convey that certain embodiments include, while other embodiments do not include, certain features, elements and/or states. Thus, such conditional language is not generally intended to

imply that features, elements and/or states are in any way required for one or more embodiments or that one or more embodiments necessarily include logic for deciding, with or without author input or prompting, whether these features, elements and/or states are included or are to be performed in any particular embodiment.

[0129] Depending on the embodiment, certain acts, events, or functions of any of the methods described herein can be performed in a different sequence, can be added, merged, or left out altogether (e.g., not all described acts or events are necessary for the practice of the method). Moreover, in certain embodiments, acts or events can be performed concurrently, e.g., through multi-threaded processing, interrupt processing, or multiple processors or processor cores, rather than sequentially.

[0130] The various illustrative logical blocks, modules, circuits, and algorithm steps described in connection with the embodiments disclosed herein can be implemented as electronic hardware, computer software, or combinations of both. To clearly illustrate this interchangeability of hardware and software, various illustrative components, blocks, modules, circuits, and steps have been described above generally in terms of their functionality. Whether such functionality is implemented as hardware or software depends upon the particular application and design constraints imposed on the overall system. The described functionality can be implemented in varying ways for each particular application, but such implementation decisions should not be interpreted as causing a departure from the scope of the disclosure.

[0131] The various illustrative logical blocks, modules, and circuits described in connection with the embodiments disclosed herein can be implemented or performed with a general purpose processor, a digital signal processor (DSP), an application specific integrated circuit (ASIC), a field programmable gate array (FPGA) or other programmable logic device, discrete gate or transistor logic, discrete hardware components, or any combination thereof designed to perform the functions described herein. A general purpose processor can be a microprocessor, but in the alternative, the processor can be any conventional processor, controller, microcontroller, or state machine. A processor can also be implemented as a combination of computing devices, e.g., a combination of a DSP and a microprocessor, a plurality of microprocessors, one or more microprocessors in conjunction with a DSP core, or any other such configuration.

[0132] The blocks of the methods and algorithms described in connection with the embodiments disclosed herein can be embodied directly in hardware, in a software module executed by a processor, or in a combination of the two. A software module can reside in RAM memory, flash memory, ROM memory, EPROM memory, EEPROM memory, registers, a hard disk, a removable disk, a CD-ROM, or any other form of computer-readable storage medium known in the art. An exemplary storage medium is coupled to a processor such that the processor can read information from, and write information to, the storage medium. In the alternative, the storage medium can be integral to the processor. The processor and the storage medium can reside in an ASIC. The ASIC can reside in a user terminal. In the alternative, the processor and the storage medium can reside as discrete components in a user terminal.

[0133] While the above detailed description has shown, described, and pointed out novel features as applied to

various embodiments, it will be understood that various omissions, substitutions, and changes in the form and details of the devices or algorithms illustrated can be made without departing from the spirit of the disclosure. As will be recognized, certain embodiments of the inventions described herein can be embodied within a form that does not provide all of the features and benefits set forth herein, as some features can be used or practiced separately from others. The scope of certain inventions disclosed herein is indicated by the appended claims rather than by the foregoing description. All changes which come within the meaning and range of equivalency of the claims are to be embraced within their scope.

1. A physiological measurement system based on optical transmission spectroscopy comprising:

- an emitter configured to emit light at a wavelength;
- a first detector set at a shorter transmission path configured to detect a first beam of transmitted light, the detected light being attenuated by a sample tissue, the first detector further configured to output a first signal responsive to the detected light of the first beam;
- a second detector fixed at a second, longer transmission path configured to detect a second beam of transmitted light and to output a second signal responsive to the detected light of the second beam; and a processor configured to receive signals responsive to the first and second signals to determine a bulk absorbance of an analyte in the sample tissue.

2. The optical physiological measurement system of claim 1, further comprising a first thermal controller, thermally coupled to the emitter, the first thermal controller configured to regulate a temperature of the emitter.

3. The optical physiological measurement system of claim 2, wherein the first thermal controller comprises a temperature sensor, a thermoelectric cooler, and a heat sink.

4. The optical physiological measurement system of claim 2, wherein the first thermal controller is further configured to modulate the temperature of the emitter to cause the emitter to emit light comprising a range of wavelengths.

5. The optical physiological measurement system of claim 4, wherein the thermal controller further comprises a thermoelectric cooler.

6. The optical physiological measurement system of claim 5, wherein the thermoelectric cooler comprises a Peltier device.

7. The optical physiological measurement system of claim 2, wherein the emitter further comprises an operational temperature and wherein the first thermal controller is further configured to cause a change to the emitter's operational temperature.

8. The optical physiological measurement system of claim 1, wherein the second detector is optically shielded.

9. The optical physiological measurement system of claim 1, comprising a second thermal controller, thermally coupled to the first detector, configured to control the temperature of the first detector.

10. The optical physiological measurement system of claim 9, comprising a third thermal controller, thermally coupled to the second detector, configured to control the temperature of the second detector.

11. The optical physiological measurement system of claim 1, wherein the analyte is at least one of glucose, water content, and hydration.

12. (canceled)

13. The optical physiological measurement system of claim **10**, further comprising a fourth thermal controller, thermally coupled to the sample tissue, the fourth thermal controller configured to measure a temperature of the sample tissue.

14. The optical physiological measurement system of claim **13**, wherein the fourth thermal controller is further configured to regulate the temperature of the sample tissue.

15. The optical physiological measurement system of claim **1**, wherein the emitter is further configured to receive a drive signal, and wherein the processor is further configured to control the drive signal delivered to the emitter.

16. The optical physiological measurement system of claim **15**, wherein the drive signal further comprises a drive current and a duty cycle, and wherein the processor is further configured to control and vary the drive current and/or the duty cycle.

17. The optical physiological measurement system of claim **1**, further comprising an emitter that has an emission area between 1 mm-10 mm diameter.

18. The optical physiological measurement system of claim **1**, wherein a difference in distance between the emitter and the first detector and the emitter and the second detector is 0.2 mm to 1 mm.

19.-66. (canceled)

67. A method of varying light emitted in a physiological optical sensor, the method comprising:

determining a temperature, a drive current, a forward voltage, and a duty cycle of a light emitter that emits light at a first wavelength at a first time;

measuring a first indication of a physiological parameter; altering at least one of the determined temperature, drive current, forward voltage, and duty cycle of the emitter at a second time to cause the emitter to emit light at a second wavelength; and

measuring a second indication of a physiological parameter.

68. The method of claim **67**, wherein altering the determined temperature of the emitter comprises using a circuitry-based temperature alteration device or a thermal controller.

69. (canceled)

70. The method of claim **68**, wherein the circuitry-based temperature alteration device or the thermal controller comprises a Peltier device.

71. (canceled)

72.-86. (canceled)

* * * * *

专利名称(译)	无创光学生理差分光程传感器		
公开(公告)号	US20160367173A1	公开(公告)日	2016-12-22
申请号	US15/160907	申请日	2016-05-20
[标]申请(专利权)人(译)	CERCACOR LAB		
申请(专利权)人(译)	CERCACOR LABORATORIES , INC.		
当前申请(专利权)人(译)	CERCACOR LABORATORIES , INC.		
[标]发明人	DALVI CRISTIANO LESMANA FERDYAN VO HUNG POEZE JEROEN CHEN JESSE PAULEY KEVIN PAUL MATHEW MERRITT SEAN BLANK THOMAS B KIANI MASSI JOE E		
发明人	DALVI, CRISTIANO LESMANA, FERDYAN VO, HUNG POEZE, JEROEN CHEN, JESSE PAULEY, KEVIN PAUL, MATHEW MERRITT, SEAN BLANK, THOMAS B. KIANI, MASSI JOE E.		
IPC分类号	A61B5/145 A61B5/1455 A61B5/00		
CPC分类号	A61B5/145 A61B5/14532 A61B5/14552 A61B5/0002 A61B5/6801 A61B5/0008 A61B5/0075 A61B5/6838 A61B2562/0238		
优先权	62/165618 2015-05-22 US		
外部链接	Espacenet USPTO		

摘要(译)

一种光学生理传感器，被配置为对被测量的样本组织执行高速光谱扫描分析，以非侵入地预测患者的分析物水平。可以调节光学生理传感器的发射器以在不同温度下操作以发射不同波长的辐射。发射器驱动电流，占空比和正向电压的变化也可用于使发射器发射一系列波长。可以在扫描样本组织的特定波长区域期间获得信息性光谱数据。

