



US009486273B2

(12) **United States Patent**  
**Lopes et al.**

(10) **Patent No.:** **US 9,486,273 B2**  
(45) **Date of Patent:** **Nov. 8, 2016**

(54) **HIGH-DENSITY ELECTRODE-BASED MEDICAL DEVICE SYSTEM**

(71) Applicant: **Kardium Inc.**, Richmond (CA)

(72) Inventors: **Fernando Luis de Souza Lopes**, Delta (CA); **Saar Moisa**, Vancouver (CA); **Peter Josiah Hawes**, Burnbay (CA)

(73) Assignee: **KARDIUM INC.**, Richmond (CA)

(\*) Notice: Subject to any disclaimer, the term of this patent is extended or adjusted under 35 U.S.C. 154(b) by 401 days.

(21) Appl. No.: **13/793,076**

(22) Filed: **Mar. 11, 2013**

(65) **Prior Publication Data**

US 2013/0197513 A1 Aug. 1, 2013

**Related U.S. Application Data**

(63) Continuation-in-part of application No. PCT/US2012/022061, filed on Jan. 20, 2012, and a continuation-in-part of application No. PCT/US2012/022062, filed on Jan. 20, 2012.

(Continued)

(51) **Int. Cl.**

**A61B 5/042** (2006.01)

**A61B 18/14** (2006.01)

(Continued)

(52) **U.S. Cl.**

CPC ..... **A61B 18/14** (2013.01); **A61B 5/04** (2013.01); **A61B 5/0422** (2013.01);

(Continued)

(58) **Field of Classification Search**

CPC ..... A61B 18/1492; A61B 5/0422; A61B 5/6859; A61B 5/6869; A61B 2018/00351; A61B 2018/00267; A61B 2018/00357; A61B 2018/00577; A61B 2017/00367–2017/00415

USPC ..... 600/372–375, 393, 509; 606/41

See application file for complete search history.

(56) **References Cited**

U.S. PATENT DOCUMENTS

4,114,202 A 9/1978 Roy et al.

4,164,046 A 8/1979 Cooley

(Continued)

FOREIGN PATENT DOCUMENTS

CN 101797181 A 8/2010

EP 0723467 B1 4/2002

(Continued)

OTHER PUBLICATIONS

Gelbart et al, "Apparatus and Method for Intra-Cardiac Mapping and Ablation", Notice of Allowance dated Oct. 23, 2014 for U.S. Appl. No. 11/475,950, 10 pgs.

(Continued)

*Primary Examiner* — Lee S Cohen

*Assistant Examiner* — Erin M Cardinal

(74) *Attorney, Agent, or Firm* — Rossi, Kimms & McDowell LLP

(57) **ABSTRACT**

A medical device system is disclosed including a high-density arrangement of transducers, which may be configured to ablate, stimulate, or sense characteristics of tissue inside a bodily cavity, such as an intra-cardiac cavity. High-density arrangements of transducers may be achieved, at least in part, by overlapping elongate members on which the transducers are located, and varying sizes, shapes, or both of the transducers, especially in view of the overlapping of the elongate members. Also, the high-density arrangements of transducers may be achieved, at least in part, by including one or more recessed portions in an elongate member in order to expose one or more transducers on an underlying elongate member in a region adjacent an elongate-member-overlap region.

**70 Claims, 14 Drawing Sheets**

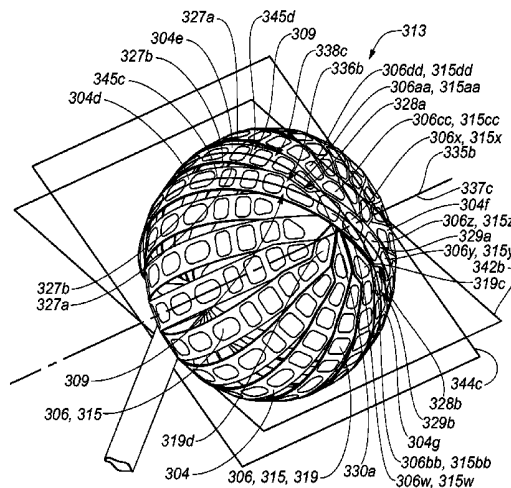

**Related U.S. Application Data**

(60) Provisional application No. 61/723,311, filed on Nov. 6, 2012, provisional application No. 61/670,881, filed on Jul. 12, 2012, provisional application No. 61/649,734, filed on May 21, 2012, provisional application No. 61/734,750, filed on Dec. 7, 2012, provisional application No. 61/435,213, filed on Jan. 21, 2011, provisional application No. 61/485,987, filed on May 13, 2011, provisional application No. 61/488,639, filed on May 20, 2011, provisional application No. 61/515,141, filed on Aug. 4, 2011.

(51) **Int. Cl.**

*A61B 5/04* (2006.01)  
*A61B 5/00* (2006.01)  
*A61B 5/053* (2006.01)  
*A61N 1/05* (2006.01)  
*A61B 18/00* (2006.01)

(52) **U.S. Cl.**

CPC ..... *A61B 5/6858* (2013.01); *A61B 18/1492* (2013.01); *A61B 5/0538* (2013.01); *A61B 5/6885* (2013.01); *A61B 2018/00267* (2013.01); *A61B 2018/00357* (2013.01); *A61B 2018/00577* (2013.01); *A61B 2018/1467* (2013.01); *A61B 2562/0209* (2013.01); *A61B 2562/0271* (2013.01); *A61B 2562/046* (2013.01); *A61N 1/056* (2013.01)

(56)

**References Cited**

U.S. PATENT DOCUMENTS

4,225,148 A 9/1980 Andersson  
 4,240,441 A 12/1980 Khalil  
 4,263,680 A 4/1981 Reul et al.  
 4,273,128 A 6/1981 Lary  
 4,411,266 A 10/1983 Cosman  
 4,490,859 A 1/1985 Black et al.  
 4,543,090 A 9/1985 McCoy  
 4,699,147 A 10/1987 Chilson et al.  
 4,770,187 A 9/1988 Lash et al.  
 4,787,369 A 11/1988 Allred, III et al.  
 4,794,912 A 1/1989 Lia  
 4,850,957 A 7/1989 Summers  
 4,887,613 A 12/1989 Farr et al.  
 4,890,602 A 1/1990 Hake  
 4,890,612 A 1/1990 Kensey  
 4,893,613 A 1/1990 Hake  
 4,895,166 A 1/1990 Farr et al.  
 4,905,667 A 3/1990 Foerster et al.  
 4,921,499 A 5/1990 Hoffman et al.  
 4,940,064 A 7/1990 Desai  
 4,942,788 A 7/1990 Farr et al.  
 4,979,514 A 12/1990 Sekii et al.  
 4,998,933 A 3/1991 Eggers et al.  
 5,026,384 A 6/1991 Farr et al.  
 5,047,047 A 9/1991 Yoon  
 5,122,137 A 6/1992 Lennox  
 5,127,902 A 7/1992 Fischell  
 5,156,151 A 10/1992 Imran  
 5,174,299 A 12/1992 Nelson  
 5,176,693 A 1/1993 Pannek, Jr.  
 5,178,620 A 1/1993 Eggers et al.  
 5,192,291 A 3/1993 Pannek, Jr.  
 5,195,505 A 3/1993 Josefsen  
 5,201,316 A 4/1993 Pomeranz et al.  
 5,228,442 A 7/1993 Imran  
 5,242,386 A 9/1993 Holzer  
 5,245,987 A 9/1993 Redmond et al.  
 5,255,679 A 10/1993 Imran  
 5,279,299 A 1/1994 Imran  
 5,293,869 A 3/1994 Edwards et al.

5,312,435 A 5/1994 Nash et al.  
 5,317,952 A 6/1994 Immega  
 5,324,284 A 6/1994 Imran  
 5,327,889 A 7/1994 Imran  
 5,341,807 A 8/1994 Nardella  
 5,345,936 A 9/1994 Pomeranz et al.  
 5,351,679 A 10/1994 Mayzels et al.  
 5,366,443 A 11/1994 Eggers et al.  
 5,370,679 A 12/1994 Atlee, III  
 5,379,773 A 1/1995 Hornsby  
 5,397,321 A 3/1995 Houser et al.  
 5,419,767 A 5/1995 Eggers et al.  
 5,450,860 A 9/1995 O'Connor  
 5,465,717 A 11/1995 Imran et al.  
 5,478,353 A 12/1995 Yoon  
 5,485,849 A 1/1996 Panescu et al.  
 5,496,267 A 3/1996 Drasler et al.  
 5,499,981 A 3/1996 Kordis ..... 606/41  
 5,531,760 A 7/1996 Alwafaie  
 5,545,193 A 8/1996 Fleischman et al.  
 5,555,883 A 9/1996 Avitall  
 5,557,967 A 9/1996 Renger  
 5,575,810 A 11/1996 Swanson et al.  
 5,593,424 A 1/1997 Northrup, III  
 5,598,848 A 2/1997 Swanson et al.  
 5,599,345 A 2/1997 Edwards et al.  
 5,616,684 A 4/1997 Wakimasu et al.  
 5,620,481 A 4/1997 Desai et al.  
 5,637,090 A 6/1997 McGee et al.  
 5,662,587 A 9/1997 Grundfest et al.  
 5,681,308 A 10/1997 Edwards et al.  
 5,681,336 A 10/1997 Clement et al.  
 5,687,723 A 11/1997 Avitall  
 5,687,737 A 11/1997 Branham et al.  
 5,697,285 A 12/1997 Nappi et al.  
 5,713,896 A 2/1998 Nardella  
 5,713,942 A 2/1998 Stern et al.  
 5,716,397 A 2/1998 Myers  
 5,720,726 A 2/1998 Marcadis et al.  
 5,728,114 A 3/1998 Evans et al.  
 5,730,127 A 3/1998 Avitall  
 5,762,066 A 6/1998 Law et al.  
 5,769,846 A 6/1998 Edwards et al.  
 5,782,239 A 7/1998 Webster, Jr.  
 5,782,879 A 7/1998 Rosborough et al.  
 5,800,495 A 9/1998 Macheck et al.  
 5,823,189 A 10/1998 Kordis  
 5,824,066 A 10/1998 Gross  
 5,836,947 A 11/1998 Fleischman et al.  
 5,836,990 A 11/1998 Li  
 5,853,422 A 12/1998 Huebsch et al.  
 5,868,755 A 2/1999 Kanner et al.  
 5,876,343 A 3/1999 Teo  
 5,881,727 A 3/1999 Edwards  
 5,885,278 A 3/1999 Fleischman  
 5,891,136 A 4/1999 McGee et al.  
 5,904,711 A 5/1999 Flom et al.  
 5,916,163 A 6/1999 Panescu et al.  
 5,919,207 A 7/1999 Taheri  
 5,921,924 A 7/1999 Avitall  
 5,935,075 A 8/1999 Casscells et al.  
 5,935,079 A 8/1999 Swanson et al.  
 5,941,251 A 8/1999 Panescu et al.  
 5,944,715 A 8/1999 Goble et al.  
 5,961,440 A 10/1999 Schweich, Jr. et al.  
 5,968,040 A 10/1999 Swanson et al.  
 5,984,950 A 11/1999 Cragg et al.  
 6,001,069 A 12/1999 Tachibana et al.  
 6,001,093 A 12/1999 Swanson et al.  
 6,014,581 A 1/2000 Wayne et al.  
 6,023,638 A 2/2000 Swanson  
 6,030,382 A 2/2000 Fleischman et al.  
 6,036,689 A 3/2000 Tu et al.  
 6,063,082 A 5/2000 DeVore et al.  
 6,071,282 A 6/2000 Fleischman  
 6,104,944 A 8/2000 Martinelli  
 6,106,522 A 8/2000 Fleischman et al.  
 6,123,702 A 9/2000 Swanson et al.  
 6,138,043 A 10/2000 Avitall

(56)

References Cited

U.S. PATENT DOCUMENTS

6,142,993	A	11/2000	Whayne et al.	6,997,951	B2	2/2006	Solem et al.
6,156,046	A	12/2000	Passafaro et al.	7,001,383	B2	2/2006	Keidar
6,210,432	B1	4/2001	Solem et al.	7,025,776	B1	4/2006	Houser et al.
6,216,043	B1	4/2001	Swanson et al.	7,048,734	B1	5/2006	Fleischman et al.
6,217,573	B1	4/2001	Webster	7,050,848	B2	5/2006	Hoey et al.
6,241,747	B1	6/2001	Ruff	7,052,487	B2	5/2006	Cohn et al.
6,248,124	B1	6/2001	Pedros et al.	7,068,867	B2	6/2006	Adoram et al.
6,258,258	B1	7/2001	Sartori	7,141,019	B2	11/2006	Pearlman
6,266,550	B1	7/2001	Selmon et al.	7,144,363	B2	12/2006	Pai et al.
6,304,769	B1	10/2001	Arenson et al.	7,166,127	B2	1/2007	Spence et al.
6,306,135	B1	10/2001	Ellman et al.	7,174,201	B2	2/2007	Govari et al.
6,308,091	B1	10/2001	Avitall	7,177,677	B2	2/2007	Kaula et al.
6,319,249	B1	11/2001	Töllner	7,186,210	B2	3/2007	Feld et al.
6,322,559	B1	11/2001	Daulton et al.	7,187,964	B2	3/2007	Khoury
6,330,478	B1	12/2001	Lee et al.	7,189,202	B2	3/2007	Lau et al.
6,346,105	B1	2/2002	Tu et al.	7,255,695	B2*	8/2007	Falwell et al. .... 606/41
6,350,263	B1	2/2002	Wetzig et al.	7,276,044	B2	10/2007	Ferry et al.
6,358,258	B1	3/2002	Arcia et al.	7,279,007	B2	10/2007	Nikolic et al.
6,383,151	B1	5/2002	Diederich et al.	7,300,435	B2	11/2007	Wham et al.
6,389,311	B1	5/2002	Whayne et al.	7,303,526	B2	12/2007	Sharkey et al.
6,391,024	B1	5/2002	Sun et al.	7,335,196	B2	2/2008	Swanson et al.
6,391,048	B1	5/2002	Ginn et al.	7,481,808	B2*	1/2009	Koyfman ..... A61B 18/1492 600/372
6,391,054	B2	5/2002	Carpentier et al.	7,507,252	B2	3/2009	Lashinski et al.
6,402,781	B1	6/2002	Langberg et al.	7,530,980	B2	5/2009	Hooven
6,436,052	B1	8/2002	Nikolic et al.	7,736,388	B2	6/2010	Goldfarb et al.
6,475,223	B1	11/2002	Werp et al.	7,738,967	B2	6/2010	Salo
6,485,409	B1	11/2002	Voloshin et al.	8,103,338	B2	1/2012	Harlev et al.
6,485,482	B1	11/2002	Belef	D654,588	S	2/2012	Taube et al.
6,485,489	B2	11/2002	Teirstein et al.	8,118,853	B2	2/2012	Grewé
6,506,210	B1	1/2003	Kanner	8,150,499	B2	4/2012	Gelbart et al.
6,514,249	B1	2/2003	Maguire et al.	D660,967	S	5/2012	Braido et al.
6,529,756	B1	3/2003	Phan et al.	8,224,432	B2	7/2012	MacAdam et al.
6,537,198	B1	3/2003	Vidlund et al.	D717,954	S	11/2014	Hjelle et al.
6,537,314	B2	3/2003	Langberg et al.	9,198,713	B2	12/2015	Wallace et al.
6,540,670	B1	4/2003	Hirata et al.	2001/0003158	A1	6/2001	Kensey et al.
6,551,310	B1	4/2003	Ganz et al.	2001/0005787	A1	6/2001	Oz et al.
6,551,312	B2	4/2003	Zhang et al.	2001/0018611	A1	8/2001	Solem et al.
6,569,160	B1	5/2003	Goldin et al.	2001/0020126	A1	9/2001	Swanson et al.
6,569,198	B1	5/2003	Wilson et al.	2001/0021867	A1	9/2001	Kordis et al.
6,575,971	B2	6/2003	Hauck et al.	2002/0002329	A1	1/2002	Avitall
6,589,208	B2	7/2003	Ewers et al.	2002/0016628	A1	2/2002	Langberg et al.
6,626,930	B1	9/2003	Allen et al.	2002/0087156	A1	7/2002	Maguire et al.
6,632,238	B2	10/2003	Ginn et al.	2002/0087173	A1	7/2002	Alferness et al.
6,635,056	B2	10/2003	Kadhiresan et al.	2002/0099415	A1	7/2002	Panescu et al.
6,640,119	B1	10/2003	Budd et al.	2002/0107478	A1	8/2002	Wendlandt
6,662,034	B2	12/2003	Segner et al.	2002/0107511	A1	8/2002	Collins et al.
D484,979	S	1/2004	Fontaine	2002/0107530	A1	8/2002	Saucer et al.
6,704,590	B2	3/2004	Haldeman	2002/0115941	A1	8/2002	Whayne et al.
6,723,038	B1	4/2004	Schroeder et al.	2002/0115944	A1	8/2002	Mendes et al.
6,726,716	B2	4/2004	Marquez	2002/0169504	A1	11/2002	Alferness et al.
6,760,616	B2	7/2004	Hoey et al.	2002/0177782	A1	11/2002	Penner
6,780,197	B2	8/2004	Roe et al.	2002/0183836	A1	12/2002	Liddicoat et al.
6,788,969	B2	9/2004	Dupree et al.	2002/0183841	A1	12/2002	Cohn et al.
6,797,001	B2	9/2004	Mathis et al.	2002/0188170	A1	12/2002	Santamore et al.
6,800,090	B2	10/2004	Alferness et al.	2003/0028118	A1	2/2003	Dupree et al.
6,824,562	B2	11/2004	Mathis et al.	2003/0028183	A1	2/2003	Sanchez et al.
6,837,886	B2	1/2005	Collins et al.	2003/0050685	A1	3/2003	Nikolic et al.
6,852,076	B2	2/2005	Nikolic et al.	2003/0055420	A1	3/2003	Kadhiresan et al.
6,855,143	B2	2/2005	Davison et al.	2003/0069570	A1	4/2003	Witzel et al.
6,890,353	B2	5/2005	Cohn et al.	2003/0069636	A1	4/2003	Solem et al.
6,892,091	B1	5/2005	Ben-Haim et al.	2003/0078465	A1	4/2003	Pai et al.
6,899,674	B2	5/2005	Viebach et al.	2003/0078671	A1	4/2003	Lesniak et al.
6,907,297	B2	6/2005	Wellman et al.	2003/0105384	A1	6/2003	Sharkey et al.
6,908,478	B2	6/2005	Alferness et al.	2003/0105520	A1	6/2003	Alferness et al.
6,913,576	B2	7/2005	Bowman	2003/0109770	A1	6/2003	Sharkey et al.
6,918,903	B2	7/2005	Bass	2003/0176810	A1	9/2003	Maahs et al.
6,926,669	B1	8/2005	Stewart et al.	2003/0181819	A1	9/2003	Desai
6,942,657	B2	9/2005	Sinofsky et al.	2003/0229395	A1	12/2003	Cox
6,949,122	B2	9/2005	Adams et al.	2004/0002626	A1	1/2004	Feld et al.
6,960,206	B2	11/2005	Keane	2004/0054279	A1	3/2004	Hanley
6,960,229	B2	11/2005	Mathis et al.	2004/0133220	A1	7/2004	Lashinski et al.
6,986,775	B2	1/2006	Morales et al.	2004/0133273	A1	7/2004	Cox
6,989,010	B2	1/2006	Francischelli et al.	2004/0138744	A1	7/2004	Lashinski et al.
6,989,028	B2	1/2006	Lashinski et al.	2004/0153146	A1	8/2004	Lashinski et al.
6,994,093	B2	2/2006	Murphy et al.	2004/0158321	A1	8/2004	Reuter et al.
				2004/0176797	A1	9/2004	Opolski
				2004/0181139	A1	9/2004	Falwell et al.
				2004/0186566	A1	9/2004	Hindrichs et al.

(56)

References Cited

U.S. PATENT DOCUMENTS

2004/0215232 A1 10/2004 Belhe et al.  
 2004/0243170 A1 12/2004 Suresh et al.  
 2004/0249408 A1 12/2004 Murphy et al.  
 2004/0249453 A1 12/2004 Cartledge et al.  
 2004/0267358 A1 12/2004 Reitan  
 2005/0004668 A1 1/2005 Aklog et al.  
 2005/0015109 A1 1/2005 Lichtenstein  
 2005/0054938 A1 3/2005 Wehman et al.  
 2005/0055089 A1 3/2005 Macoviak et al.  
 2005/0060030 A1 3/2005 Lashinski et al.  
 2005/0064665 A1 3/2005 Han  
 2005/0065420 A1 3/2005 Collins et al.  
 2005/0065504 A1 3/2005 Melsky et al.  
 2005/0080402 A1 4/2005 Santamore et al.  
 2005/0096047 A1 5/2005 Haberman et al.  
 2005/0096647 A1 5/2005 Steinke et al.  
 2005/0107723 A1 5/2005 Wehman et al.  
 2005/0107871 A1 5/2005 Realyvasquez et al.  
 2005/0125030 A1 6/2005 Forsberg et al.  
 2005/0148892 A1 7/2005 Desai  
 2005/0149014 A1 7/2005 Hauck et al.  
 2005/0149159 A1 7/2005 Andreas et al.  
 2005/0154252 A1 7/2005 Sharkey et al.  
 2005/0182365 A1 8/2005 Hennemann  
 2005/0187620 A1 8/2005 Pai et al.  
 2005/0197593 A1 9/2005 Burbank et al.  
 2005/0197692 A1 9/2005 Pai et al.  
 2005/0197693 A1 9/2005 Pai et al.  
 2005/0197694 A1 9/2005 Pai et al.  
 2005/0203558 A1 9/2005 Maschke  
 2005/0209636 A1 9/2005 Widomski et al.  
 2005/0216054 A1 9/2005 Widomski et al.  
 2005/0240249 A1 10/2005 Tu et al.  
 2005/0251116 A1 11/2005 Steinke et al.  
 2005/0251132 A1 11/2005 Oral et al.  
 2005/0256521 A1 11/2005 Kozel  
 2005/0261580 A1 11/2005 Willis et al.  
 2005/0267458 A1 12/2005 Paul et al.  
 2005/0267574 A1 12/2005 Cohn et al.  
 2006/0009755 A1 1/2006 Sra  
 2006/0009756 A1 1/2006 Francischelli et al.  
 2006/0014998 A1 1/2006 Sharkey et al.  
 2006/0015002 A1 1/2006 Moaddeb et al.  
 2006/0015003 A1 1/2006 Moaddeb et al.  
 2006/0015038 A1 1/2006 Weymarn-Scharli  
 2006/0015096 A1 1/2006 Hauck et al.  
 2006/0025800 A1 2/2006 Suresh  
 2006/0030881 A1 2/2006 Sharkey et al.  
 2006/0085049 A1 4/2006 Cory et al.  
 2006/0089637 A1 4/2006 Werneth et al.  
 2006/0100618 A1 5/2006 Chan et al.  
 2006/0106298 A1 5/2006 Ahmed et al.  
 2006/0135968 A1 6/2006 Schaller  
 2006/0135970 A1 6/2006 Schaller  
 2006/0184242 A1 8/2006 Lichtenstein  
 2006/0199995 A1 9/2006 Vijay  
 2006/0229491 A1 10/2006 Sharkey et al.  
 2006/0235286 A1 10/2006 Stone et al.  
 2006/0235314 A1 10/2006 Migliuolo et al.  
 2006/0264980 A1 11/2006 Khairkhahan et al.  
 2006/0281965 A1 12/2006 Khairkhahan et al.  
 2006/0293698 A1 12/2006 Douk  
 2006/0293725 A1 12/2006 Rubinsky et al.  
 2007/0016068 A1 1/2007 Grunwald et al.  
 2007/0027533 A1 2/2007 Douk  
 2007/0038208 A1 2/2007 Kefer  
 2007/0083193 A1 4/2007 Werneth et al.  
 2007/0083195 A1 4/2007 Werneth et al.  
 2007/0088362 A1 4/2007 Bonutti et al.  
 2007/0115390 A1 5/2007 Makara et al.  
 2007/0118215 A1 5/2007 Moaddeb  
 2007/0129717 A1 6/2007 Brown, III et al.  
 2007/0161846 A1 7/2007 Nikolic et al.  
 2007/0198058 A1 8/2007 Gelbart et al.  
 2007/0213578 A1 9/2007 Khairkhahan et al.

2007/0213815 A1 9/2007 Khairkhahan et al.  
 2007/0232858 A1 10/2007 Macnamara et al.  
 2007/0249999 A1 10/2007 Sklar et al.  
 2007/0270688 A1 11/2007 Gelbart et al.  
 2007/0299343 A1 12/2007 Waters  
 2008/0004534 A1 1/2008 Gelbart et al.  
 2008/0004643 A1 1/2008 To et al.  
 2008/0004697 A1 1/2008 Lichtenstein et al.  
 2008/0045778 A1 2/2008 Lichtenstein et al.  
 2008/0071298 A1 3/2008 Khairkhahan et al.  
 2008/0262337 A1 \* 10/2008 Falwell et al. .... 600/374  
 2008/0281322 A1 11/2008 Sherman et al.  
 2008/0312713 A1 12/2008 Wilfley et al.  
 2009/0018617 A1 1/2009 Skelton et al.  
 2009/0024138 A1 1/2009 Saleh  
 2009/0069704 A1 3/2009 MacAdam et al.  
 2009/0131930 A1 5/2009 Gelbart et al.  
 2009/0157058 A1 6/2009 Ferren et al.  
 2009/0171274 A1 7/2009 Harlev et al.  
 2009/0192441 A1 7/2009 Gelbart et al.  
 2009/0270737 A1 10/2009 Thornton  
 2009/0287271 A1 11/2009 Blum et al.  
 2009/0287304 A1 11/2009 Dahlgren et al.  
 2010/0121147 A1 5/2010 Oskin et al.  
 2010/0211052 A1 8/2010 Brown et al.  
 2010/0249771 A1 9/2010 Pearson et al.  
 2010/0268059 A1 10/2010 Ryu et al.  
 2011/0125172 A1 5/2011 Gelbart et al.  
 2011/0172658 A1 7/2011 Gelbart et al.  
 2011/0282491 A1 11/2011 Prisco et al.  
 2012/0158016 A1 6/2012 Gelbart et al.  
 2012/0165829 A1 6/2012 Chen et al.  
 2012/0271135 A1 10/2012 Burke et al.  
 2013/0165916 A1 \* 6/2013 Mathur ..... A61B 18/18  
 2013/0172883 A1 7/2013 Lopes et al.  
 2013/0178850 A1 7/2013 Lopes et al.  
 2013/0178851 A1 7/2013 Lopes et al.  
 2013/0184705 A1 7/2013 Gelbart et al.  
 2013/0184706 A1 7/2013 Gelbart et al.  
 2013/0190587 A1 7/2013 Lopes et al.  
 2013/0241929 A1 9/2013 Massarwa et al.  
 2013/0304065 A1 11/2013 Lopes et al.  
 2013/0310828 A1 11/2013 Reinders et al.  
 2014/0114307 A1 4/2014 Moisa et al.  
 2014/0350552 A1 11/2014 Highsmith  
 2015/0126993 A1 5/2015 Gelbart et al.

FOREIGN PATENT DOCUMENTS

WO 95/10320 A1 4/1995  
 WO 95/20349 A1 8/1995  
 WO 97/17892 A1 5/1997  
 WO 0108575 A2 2/2001  
 WO WO 02087437 A1 \* 11/2002  
 WO 03/015611 A2 2/2003  
 WO 03/077800 A1 9/2003  
 WO 2004/012629 A1 2/2004  
 WO 2004/047679 A1 6/2004  
 WO 2004/084746 A2 10/2004  
 WO 2004/100803 A1 11/2004  
 WO 2005/070330 A1 8/2005  
 WO 2005/102181 A1 11/2005  
 WO 2006/017809 A2 2/2006  
 WO 2006/105121 A2 10/2006  
 WO 2006/135747 A2 12/2006  
 WO 2006/135749 A2 12/2006  
 WO 2007/021647 A2 2/2007  
 WO 2007/115390 A1 10/2007  
 WO 2008/002606 A2 1/2008  
 WO 2009011721 A1 1/2009  
 WO 2009/065042 A2 5/2009  
 WO 2012/100184 A2 7/2012

(56) **References Cited**

## FOREIGN PATENT DOCUMENTS

WO 2012/100185 A2 7/2012  
 WO 2013/173917 A1 11/2013

## OTHER PUBLICATIONS

- Gelbart et al., "Medical Device for Use in Bodily Lumens, for Example an Atrium", Supplemental Notice of Allowance dated Oct. 6, 2014 for U.S. Appl. No. 11/941,819, 4 pgs.
- Gelbart et al., Medical Device for Use in Bodily Lumens, for Example an Atrium, Amendment filed Sep. 22, 2014, for co-pending U.S. Appl. No. 13/070,215, 18 pgs.
- Gelbart et al., "Medical Device for Use in Bodily Lumens, for Example an Atrium", Notice of Allowance mailed Nov. 13, 2014 for U.S. Appl. No. 13/070,215, 54 pages.
- Official Action issued in CN201280004400.9, mailed Dec. 3, 2014.
- International Search Report and Written Opinion mailed Aug. 2, 2013 issued in PCT/CA2013/050350.
- International Search Report and Written Opinion mailed Sep. 17, 2013 issued in PCT/US2013/039982.
- International Search Report and Written Opinion mailed Sep. 27, 2013 issued in PCT/US2013/039977.
- Non-final Office Action issued in co-pending U.S. Appl. No. 13/782,867, dated Apr. 15, 2015.
- Non-final Office Action issued in co-pending U.S. Appl. No. 13/782,903, dated Apr. 28, 2015.
- Extended European Search Report for corresponding EP 12736677.1, mail date Mar. 28, 2014.
- Extended European Search Report for corresponding EP 12736962.7, mail date Mar. 28, 2014.
- Lopes et al., "Enhanced Medical Device for Use in Bodily Cavities, for Example an Atrium", Office Action mailed May 22, 2015 for U.S. Appl. No. 13/782,889, 86 pages.
- Becker, et al., "Ablation of Atrial Fibrillation: Energy Sources and Navigation Tools: A Review", *Journal of Electrocardiology*, vol. 37, Supplement 2004, pp. 55-62.
- Buchbinder, Maurice, "Dynamic Mitral Valve Annuloplasty: A Reshapable Ring for Residual and Recurring MR", *Foundation for Cardiovascular Medicine*, May 24, 2007.
- Calkins, Hugh, "Electrophysiology: Radiofrequency Catheter Ablation of Supraventricular Arrhythmias", *Heart*, 2001; 85; pp. 594-600.
- De Ponti, et al., "Non-Fluoroscopic Mapping Systems for Electrophysiology: the Tool or Toy Dilemma After 10 Years", *European Heart Journal*, 2006; 27, pp. 1134-1136.
- Gabriel, et al., "The Dielectric Properties of Biological Tissues: I. Literature Survey", *Phys. Med. Biol.*; 41, 1996, pp. 2231-2249.
- Konings, et al., "Development of an Intravascular Impedance Catheter for Detection of Fatty Lesions in Arteries", *IEEE Transactions on Medical Imaging*, vol. 16, No. 4, Aug. 1997, pp. 439-446.
- Mack, Michael J., "New Techniques for Percutaneous Repair of the Mitral Valve", *Heart Fail Rev*, 2006; 11, pp. 259-268.
- Otasevic, et al., "First-in-Man Implantation of Left Ventricular Partitioning Device in a Patient With Chronic Heart Failure: Twelve-Month Follow-Up", *Journal of Cardiac Failure*, vol. 13, No. 7, 2007, pp. 517-520.
- Sharkey, et al., "Left Ventricular Apex Occluder. Description of a Ventricular Partitioning Device", *EuroIntervention*, 2006, pp. 125-127.
- Stiles, et al., "Simulated Characterization of Atherosclerotic Lesions in the Coronary Arteries by Measurement of Bioimpedance", *IEEE Transactions on Biomedical Engineering*, vol. 50, No. 7, Jul. 2003, pp. 916-921.
- Tanaka, et al., "Artificial SMA Valve for Treatment of Urinary Incontinence: Upgrading of Valve and Introduction of Transcutaneous Transformer", *Bio-Medical Materials and Engineering*; vol. 9, 1999, pp. 97-112.
- Timek, et al., "Septal-Lateral Annular Cinching Abolishes Acute Ischemic Mitral Regurgitation", *Journal of Thoracic and Cardiovascular Surgery*, vol. 123, No. 5, May 2002, pp. 881-888.
- Timek, et al., "Septal-Lateral Annular Cinching (SLAC) Reduces Mitral Annular Size Without Perturbing Normal Annular Dynamics", *Journal of Heart Valve Disease*, vol. 11, No. 1, Jan. 2002.
- Valvano, et al., "Thermal Conductivity and Diffusivity of Biomaterials Measured with Self-Heated Thermistors", *International Journal of Thermophysics*, vol. 6, No. 3, 1985, pp. 301-311.
- International Search Report, mailed Dec. 5, 2007 for PCT/US2007/014902, 5 pages.
- International Search Report, mailed Dec. 2, 2009 for PCT/US2008/083644, 5 pages.
- International Preliminary Report on Patentability, issued Jan. 6, 2009 for PCT/US2007/014902, 8 pages.
- Written Opinion, mailed Dec. 5, 2007, for PCT/US2007/014902, 7 pages.
- Written Opinion, mailed Dec. 2, 2009, for PCT/US2008/083644, 9 pages.
- "Phased RF Catheter Ablation System", 2014 Medtronic Inc., 2 pgs, <http://www.medtronic.eu/your-health/atrial-fibrillation/about-the-therapy/our-phased-rf-ablation-system/>[Jun. 24, 2014 2:38:05 PM].
- "ThermoCool® Irrigated Tip Catheter", Brochure, Biosense Webster, 4 pgs, Biosense Webster, Inc. 3333 Diamond Canyon Road Diamond Bar, CA 91765, USA, © Biosense Webster, Inc. 2009 All rights reserved. 1109003.0.
- Biotronik'S "AlCath Flutter Gold Cath for Atrial Flutter Available in EU", medGadget, 3 pgs, <http://www.medgadget.com/2013/09/biotroniks-alcath-flutter-gold-cath-for-atrial-flutter-unveiled-in-europe.html>[Jun. 24, 2014 2:37:09 PM].
- Extended European Search Report mailed Aug. 20, 2013 issued in EP Patent Application No. 13172848.7.
- Gelbart et al., "Intra-Cardiac Mapping and Ablation Method", Pre Amend filed Aug. 29, 2007 for U.S. Appl. No. 11/475,950, 42 pgs.
- Gelbart et al., "Automatic Atherectomy System", Amendment filed Oct. 25, 2010 for U.S. Appl. No. 11/436,584, 9 pgs.
- Gelbart et al., "Automatic Atherectomy System", Amendment filed Mar. 30, 2010 for U.S. Appl. No. 11/436,584, 20 pgs.
- Gelbart et al., "Automatic Atherectomy System", Amendment filed Aug. 4, 2009 for U.S. Appl. No. 11/436,584, 35 pgs.
- Gelbart et al., "Automatic Atherectomy System", Amendment filed Sep. 15, 2011 for U.S. Appl. No. 12/950,871, 21 pgs.
- Gelbart et al., "Automatic Atherectomy System", Office Action mailed Jun. 15, 2011 for U.S. Appl. No. 12/950,871, 16 pgs.
- Gelbart et al., "Automatic Atherectomy System", Office Action mailed Dec. 1, 2009 for U.S. Appl. No. 11/436,584, 8 pgs.
- Gelbart et al., "Automatic Atherectomy System", Office Action mailed Dec. 14, 2010 for U.S. Appl. No. 11/436,584, 12 pgs.
- Gelbart et al., "Automatic Atherectomy System", Office Action mailed Mar. 4, 2009 for U.S. Appl. No. 11/436,584, 6 pgs.
- Bard, "HD Mesh Ablator Catheter", Brochure, 2008, 4 pgs, Bard Electrophysiology Division, C.R. Bard Inc., 55 Technology Drive Lowell, MA 01851 USA.
- "Constellation Mapping Catheters", Brochure, Boston Scientific Corp., 2 pgs, © 2007 Boston Scientific Corporation.
- Written opinion dated Jul. 30, 2012 for PCT/US2012/022062, 5 pgs.
- Written opinion dated Aug. 22, 2012 for PCT/US2012/022061, 6 pgs.
- International Search Report dated Aug. 22, 2012 for PCT/US2012/022061, 5 pgs.
- International Search Report dated Jul. 30, 2012 for PCT/US2012/022062, 5 pgs.
- Gelbart et al., "Medical Device for Use in Bodily Lumens, for Example an Atrium", Office Action mailed Jul. 25, 2011 for U.S. Appl. No. 11/941,819, now published as US 2009-0131930 A1.
- Gelbart et al., "Liposuction System", Amendment filed Jun. 10, 2011 for U.S. Appl. No. 12/010,458, 10 pgs.
- Gelbart et al., "Liposuction System", Amendment filed Dec. 7, 2011 for U.S. Appl. No. 12/010,458, 15 pgs.
- Gelbart et al., "Liposuction System", Office Action mailed Mar. 16, 2011 for U.S. Appl. No. 12/010,458, 12 pgs.
- Gelbart et al., "Liposuction System", Office Action mailed Sep. 14, 2011 for U.S. Appl. No. 12/010,458, 9 pgs.

(56)

**References Cited**

## OTHER PUBLICATIONS

“Waveforms and Segments”, Ensite System Instructions for use, 54-06154-001 Rev02, Chapter 7, pp. 85-90 © 2007 St. Jude Medical.

Gelbart et al., “Intra-Cardiac Mapping and Ablation Method”, Amendment filed Feb. 23, 2011 for U.S. Appl. No. 11/475,950, 28 pgs.

Gelbart et al., “Intra-Cardiac Mapping and Ablation Method”, Amendment filed Mar. 5, 2008 for U.S. Appl. No. 11/475,950, 11 pgs.

Gelbart et al., “Intra-Cardiac Mapping and Ablation Method”, Amendment filed Aug. 16, 2010 for U.S. Appl. No. 11/475,950, 22 pgs.

Gelbart et al., “Intra-Cardiac Mapping and Ablation Method”, Office Action mailed Nov. 23, 2010 for U.S. Appl. No. 11/475,950, 25 pgs.

Gelbart et al., “Intra-Cardiac Mapping and Ablation Method”, Office Action mailed Jun. 23, 2010 for U.S. Appl. No. 11/475,950, 18 pgs.

Gelbart et al., “Apparatus and Method for Intra-Cardiac Mapping and Ablation”, Office Action dated Dec. 13, 2013; Notice of Allowance dated Jul. 25, 2014 for co-pending U.S. Appl. No. 11/475,950, 19 pgs.

Gelbart et al., “Medical Device for Use in Bodily Lumens, for Example an Atrium”, Office Action dated Jan. 3, 2012; Office Action dated Apr. 3, 2014; Notice of Allowance dated Aug. 26, 2014 for co-pending U.S. Appl. No. 11/941,819, 35 pgs.

Gelbart et al., “Medical Device for Use in Bodily Lumens, for Example an Atrium”, Office Action dated Jun. 20, 2014, for co-pending U.S. Appl. No. 13/070,215, 8 pgs.

Gelbart et al., “Apparatus and Method for Intra-Cardiac Mapping and Ablation”, Amendment filed Apr. 10, 2014; Supplemental Amendment filed Feb. 12, 2013 for co-pending U.S. Appl. No. 11/475,950, 21 pgs.

Gelbart et al., “Apparatus and Method for Intra-Cardiac Mapping and Ablation”, Preliminary Amendment filed Aug. 22, 2014; Preliminary Amendment filed Mar. 5, 2013 for co-pending U.S. Appl. No. 13/785,910, 10 pgs.

Gelbart et al., “Apparatus and Method for Intra-Cardiac Mapping and Ablation”, Preliminary Amendment filed Aug. 22, 2014; Preliminary Amendment filed Mar. 5, 2013 for co-pending U.S. Appl. No. 13/785,931, 10 pgs.

Lopes et al., “Enhanced Medical Device for Use in Bodily Cavities, for Example an Atrium”, Preliminary Amendment filed Oct. 22, 2013 for co-pending U.S. Appl. No. 13/942,354, 13 pgs.

Lopes et al., “Enhanced Medical Device for Use in Bodily Cavities, for Example an Atrium”, Preliminary Amendment filed Aug. 20, 2014 for co-pending U.S. Appl. No. 13/782,889, 11 pgs.

Lopes et al., “Enhanced Medical Device for Use in Bodily Cavities, for Example an Atrium”, Preliminary Amendment filed Mar. 14, 2013 for co-pending U.S. Appl. No. 13/782,867, 8 pgs.

Gelbart et al., “Medical Device for Use in Bodily Lumens, for Example an Atrium”, Amendment filed Jul. 3, 2014; Amendment filed Apr. 2, 2012; Amendment filed Mar. 1, 2012; Amendment filed Nov. 23, 2011; Replacement drawings filed Feb. 13, 2008 for U.S. Appl. No. 11/941,819, 155 pgs.

Gelbart et al., “Medical Device for Use in Bodily Lumens, for Example an Atrium”, Preliminary Amendment filed May 12, 2014; Preliminary Amendment filed May 2, 2014 for U.S. Appl. No. 14/229,305, 12 pgs.

Gelbart et al., “Medical Device for Use in Bodily Lumens, for Example an Atrium”, Preliminary Amendment filed May 12, 2014; Preliminary Amendment filed May 2, 2014 for U.S. Appl. No. 14/229,250, 10 pgs.

International Search Report mailed Mar. 10, 2015, for International Application PCT/CA2014/051144; 10 pages.

Written Opinion mailed Mar. 10, 2015, for International Application PCT/CA2014/051144; 4 pages.

Biotronik’s “AICath Flutter Gold Cath for Atrial Flutter Available in EU”, Sep. 19, 2013, medGadget, 3 pgs, <http://www.medgadget.com/2013/09/biotroniks-alcath-flutter-gold-cath-for-atrial-flutter-unveiled-in-europe.html> [Jun. 24, 2014 2:37:09 PM].

Office Action issued in U.S. Appl. No. 13/782,889, mailed Dec. 18, 2015.

Office Action issued in U.S. Appl. No. 13/782,903, mailed Dec. 18, 2015.

Gelbart et al., “Apparatus and Method for Intra-Cardiac Mapping and Ablation”, Office Action mailed Aug. 5, 2015 for U.S. Appl. No. 13/785,910, 79 pages.

Lopes et al., “High-Density Electrode-Based Medical Device System”, Office Action mailed Jul. 9, 2015 for U.S. Appl. No. 13/793,213, 99 pages.

Lopes et al., “Enhanced Medical Device for Use in Bodily Cavities, for Example an Atrium”, Amendment filed Aug. 24, 2015 for U.S. Appl. No. 13/782,889, 21 pages.

Lopes et al., “Enhanced Medical Device for Use in Bodily Cavities, for Example an Atrium”, Amendment filed Aug. 28, 2015 for U.S. Appl. No. 13/782,903, 19 pages.

Lopes et al., “Enhanced Medical Device for Use in Bodily Cavities, for Example an Atrium”, Amendment filed Sep. 14, 2015 for U.S. Appl. No. 13/782,867, 25 pages.

Lopes et al., “High-Density Electrode-Based Medical Device System”, Amendment filed Oct. 9, 2015 for U.S. Appl. No. 13/793,213, 26 pages.

Moisa et al., “Catheter System”, Office Action mailed Nov. 16, 2015 for U.S. Appl. No. 14/136,946, 92 pages.

Extended European Search Report issued in EP13793216.6, mailed Oct. 30, 2015.

Extended European Search Report issued in EP15188407.9, mailed Jan. 21, 2016.

Lopes et al. “Enhanced Medical Device for Use in Bodily Cavities, for Example an Atrium”, Office Action mailed Jan. 25, 2016 for U.S. Appl. No. 13/782,867, 49 pages.

Examination Report issued in EP13172848.7, mailed Sep. 21, 2015. Non-Final Office Action issued in U.S. Appl. No. 29/509,719, dated Feb. 25, 2016.

Final Office Action issued in U.S. Appl. No. 13/793,213, dated Feb. 26, 2016.

Duayle issued in U.S. Appl. No. 29/509,621, dated Feb. 26, 2016.

Duayle issued in U.S. Appl. No. 29/509,636, dated Feb. 26, 2016. Non-Final Office Action issued in U.S. Appl. No. 13/785,910 mailed Apr. 8, 2016.

Non-Final Office Action issued in U.S. Appl. No. 14/229,250 mailed Apr. 28, 2016.

Non-Final Office Action issued in U.S. Appl. No. 14/229,305 mailed Apr. 29, 2016.

\* cited by examiner

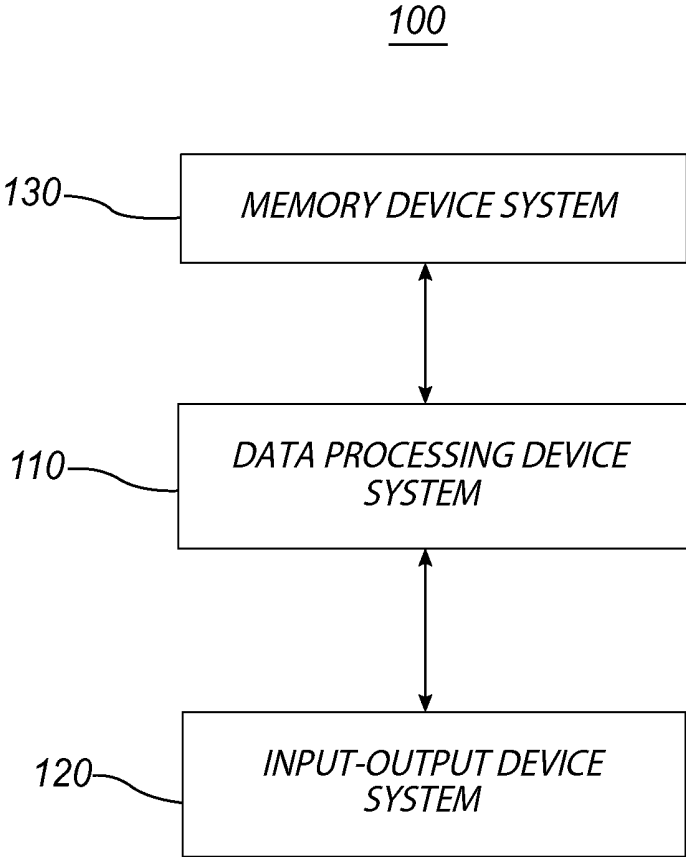

FIG. 1

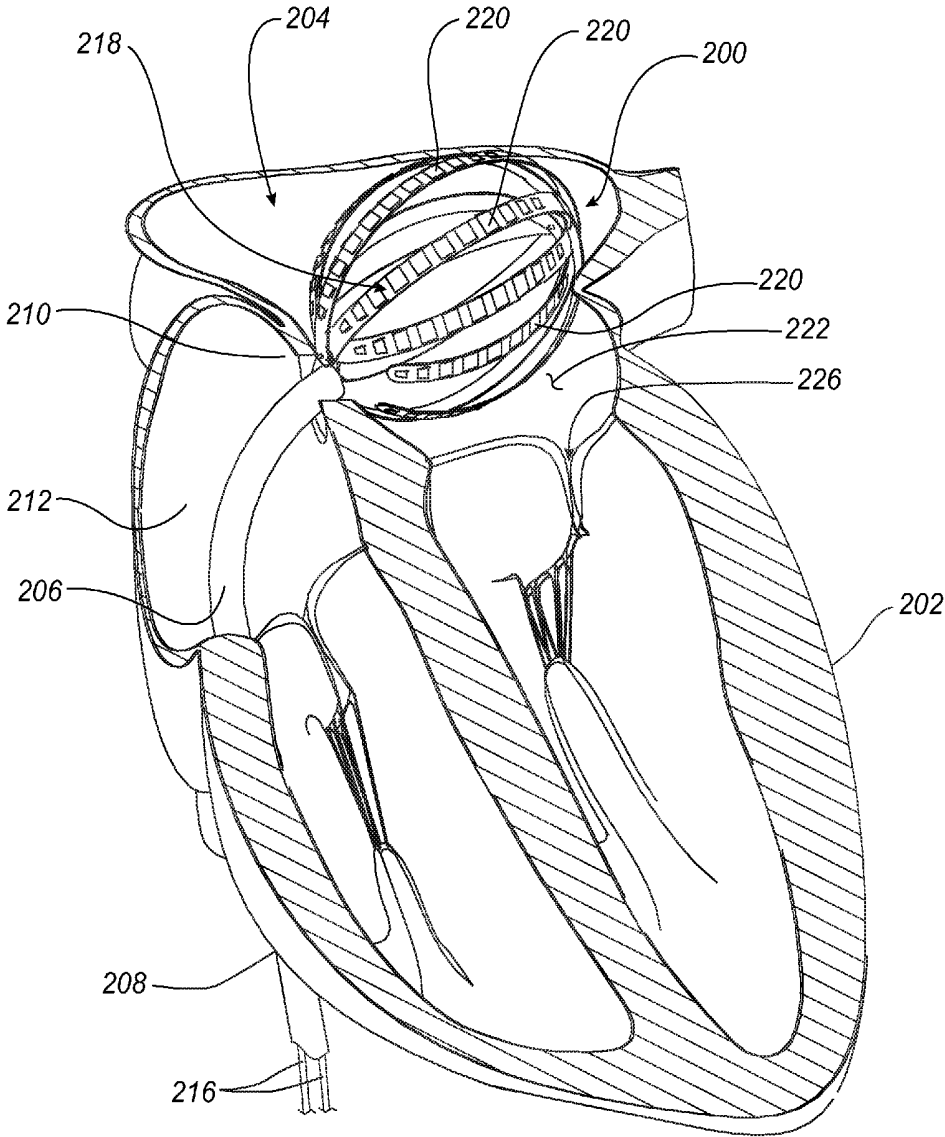

FIG. 2

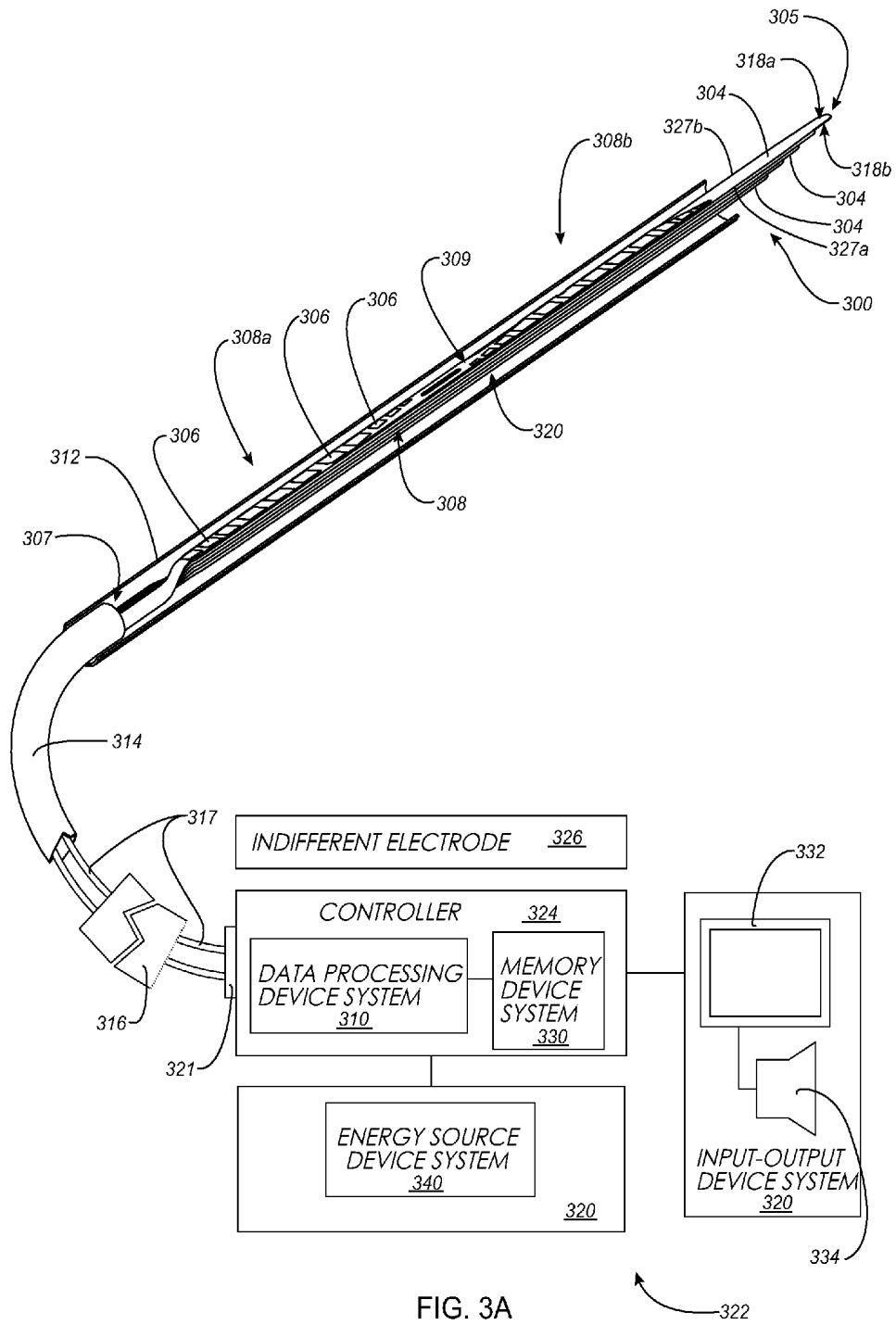

FIG. 3A

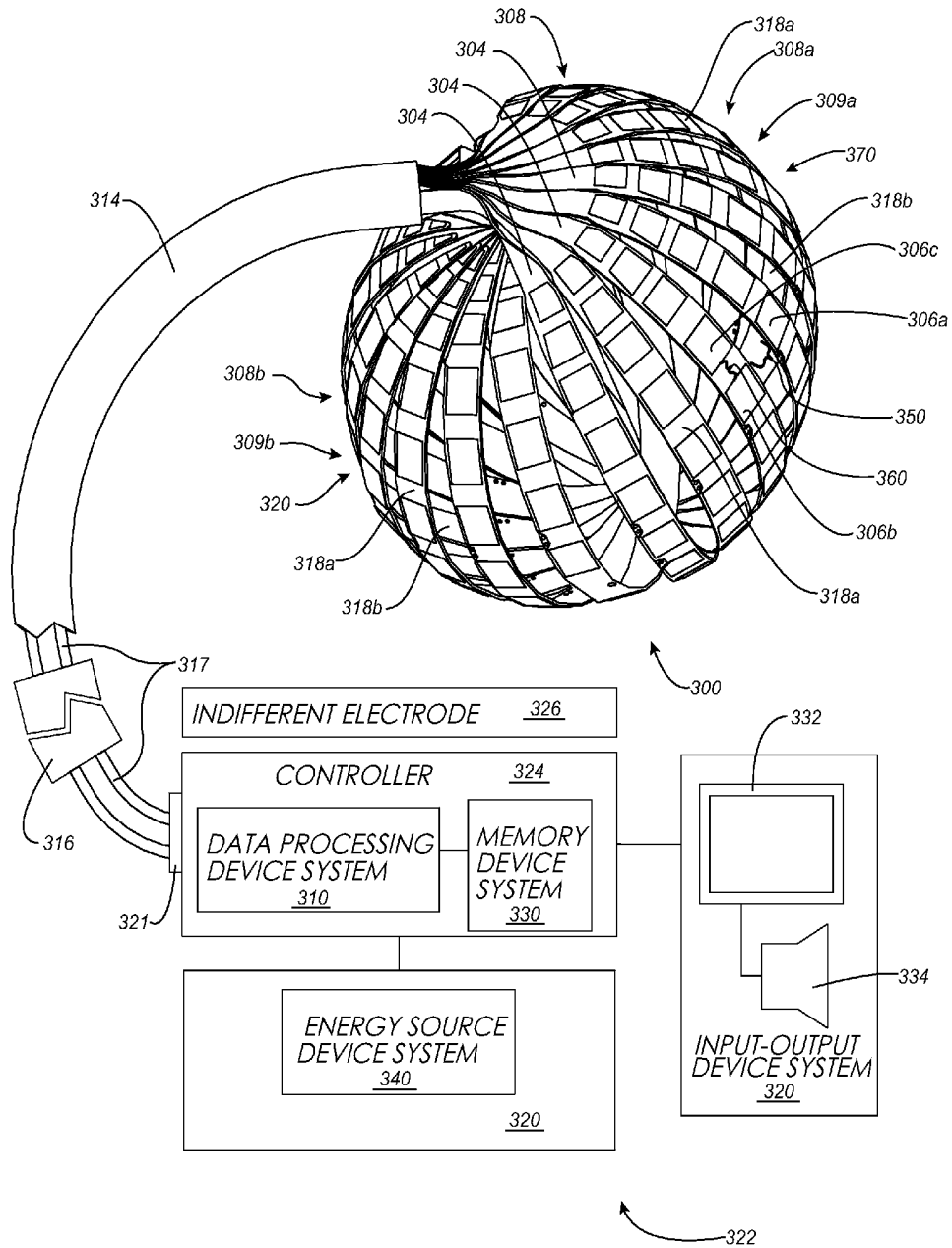

FIG. 3B

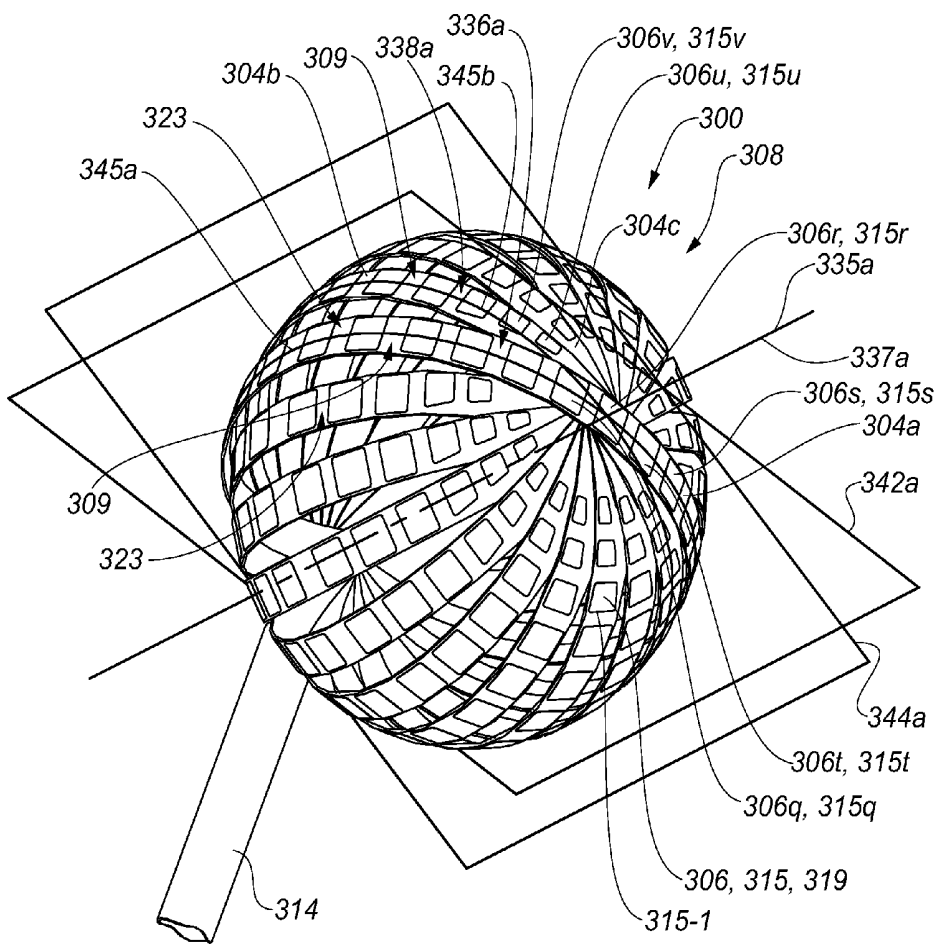

FIG. 3C

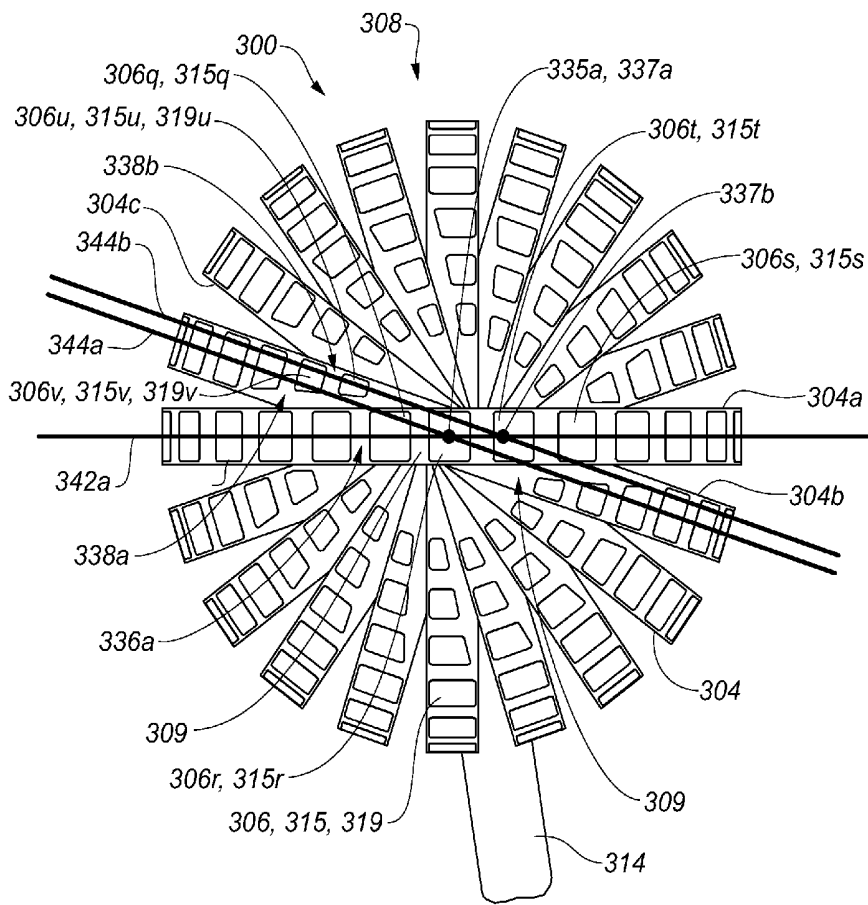

FIG. 3D

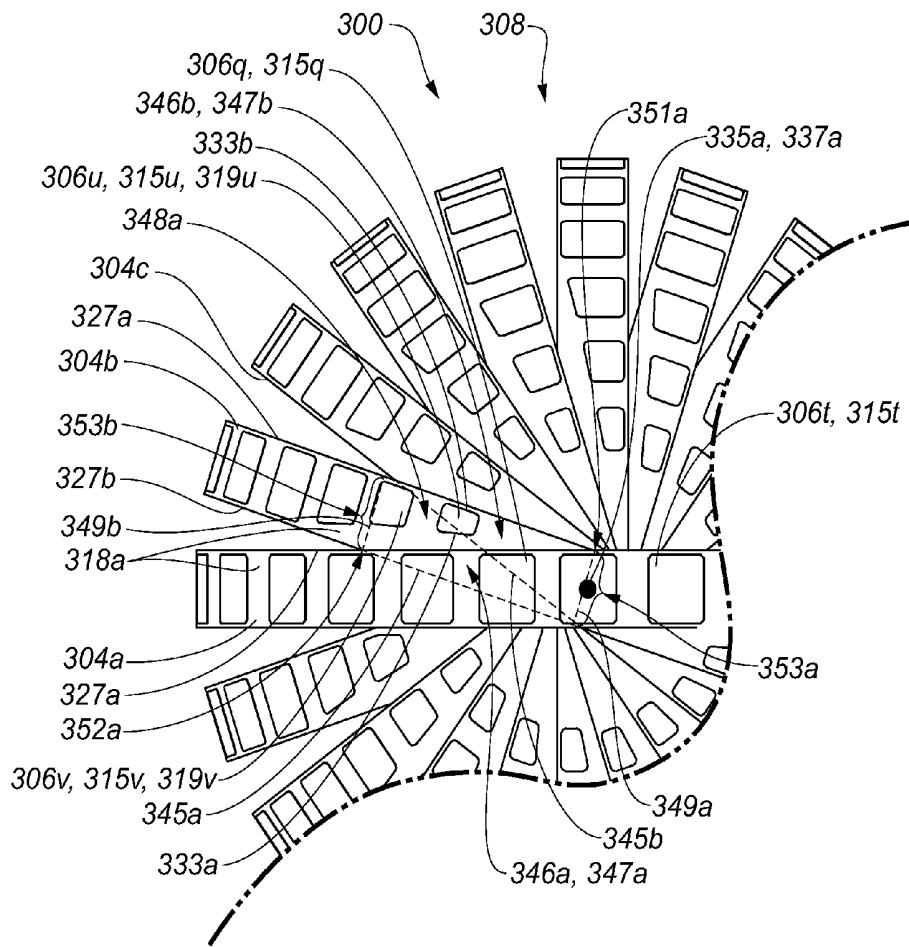

FIG. 3E

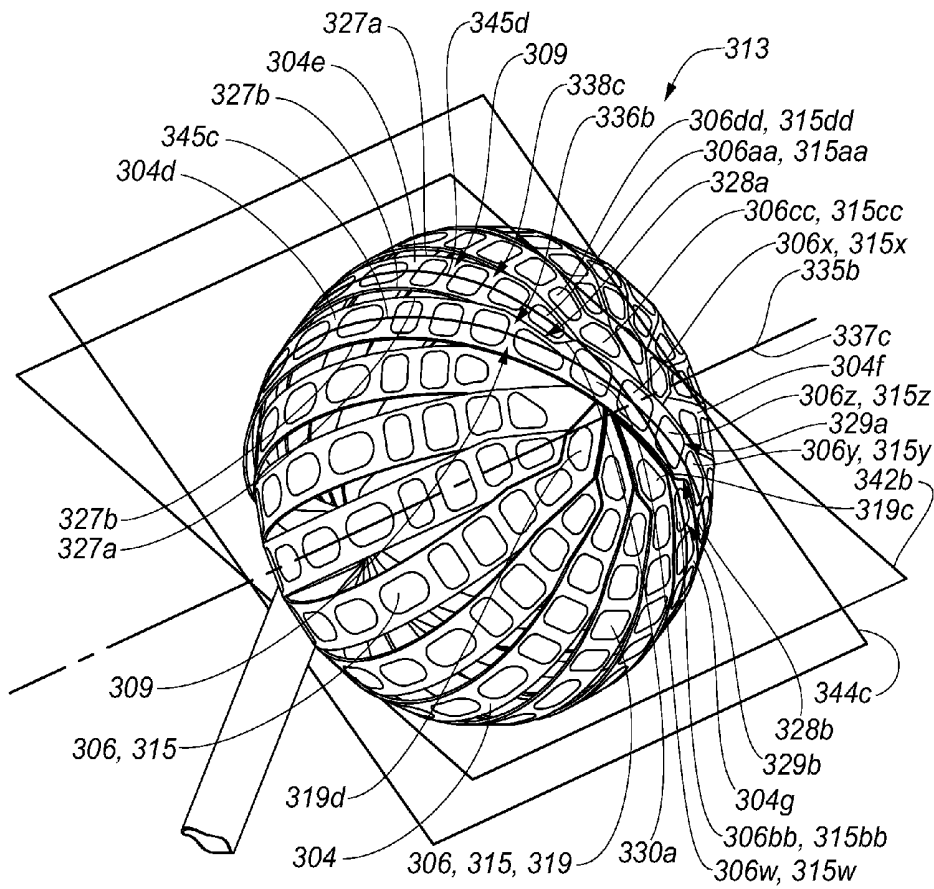

FIG. 3F

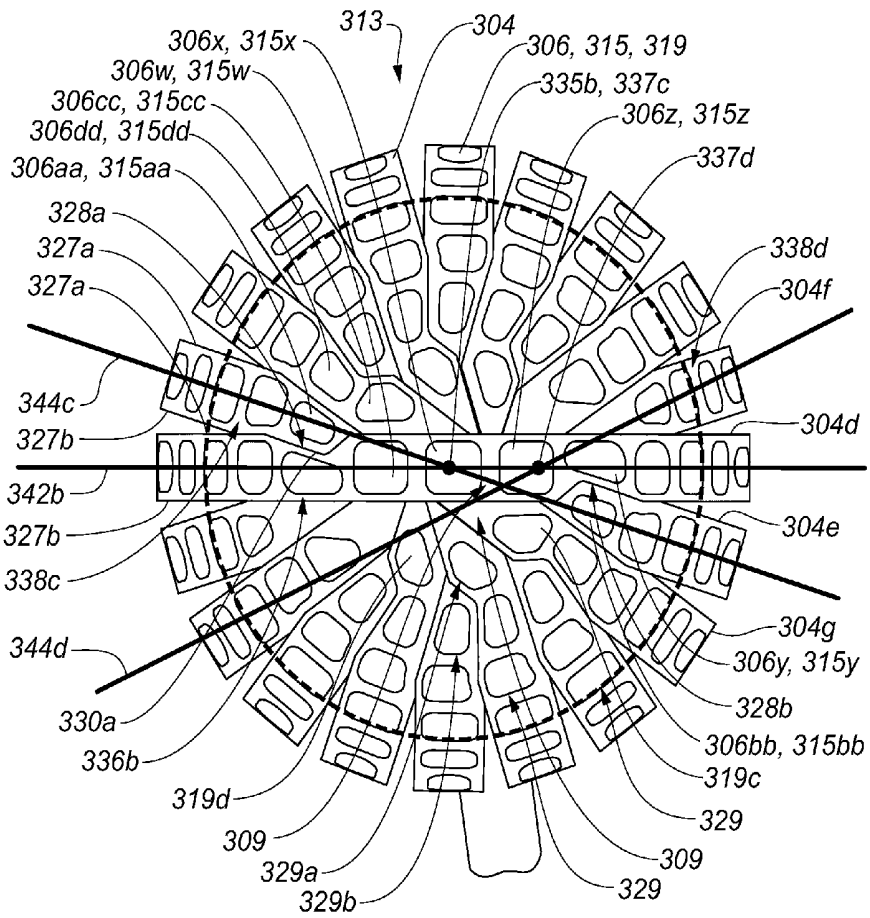

FIG. 3G

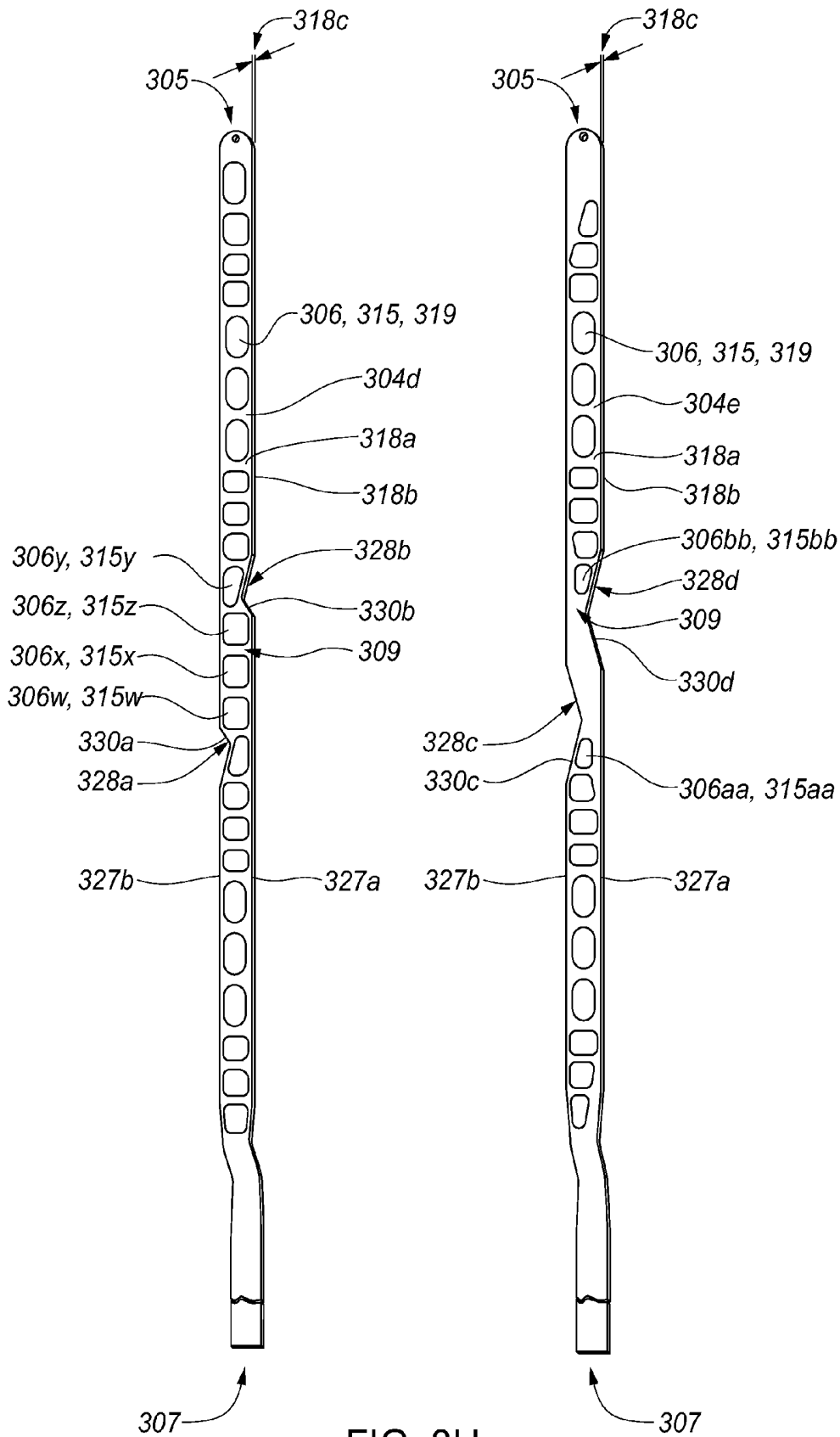

FIG. 3H

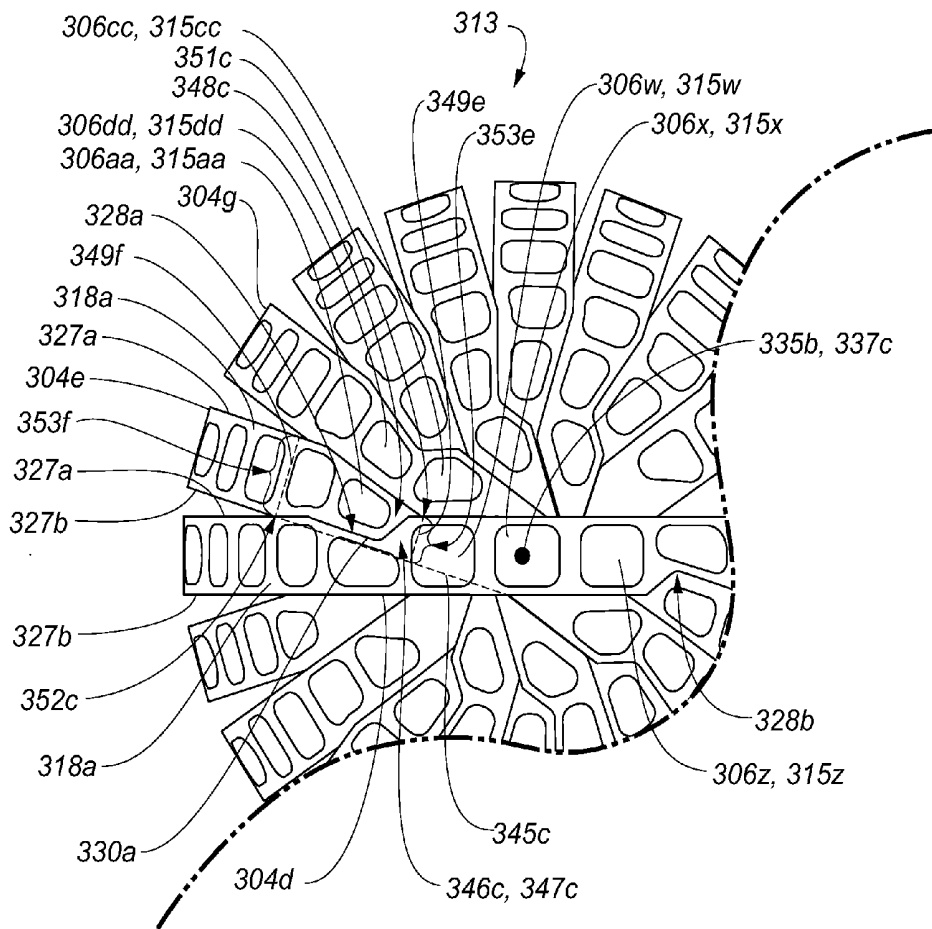

FIG. 3I

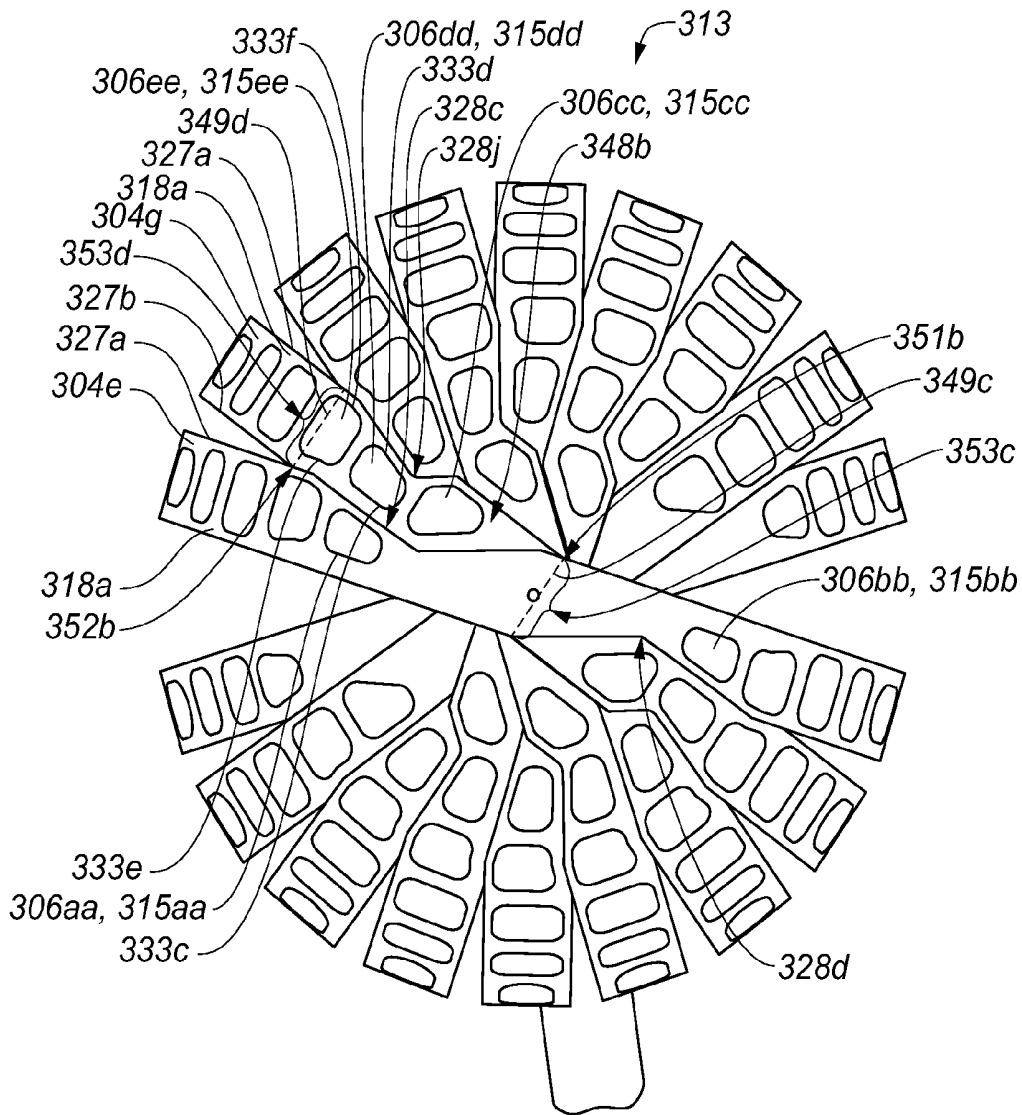

FIG. 3J

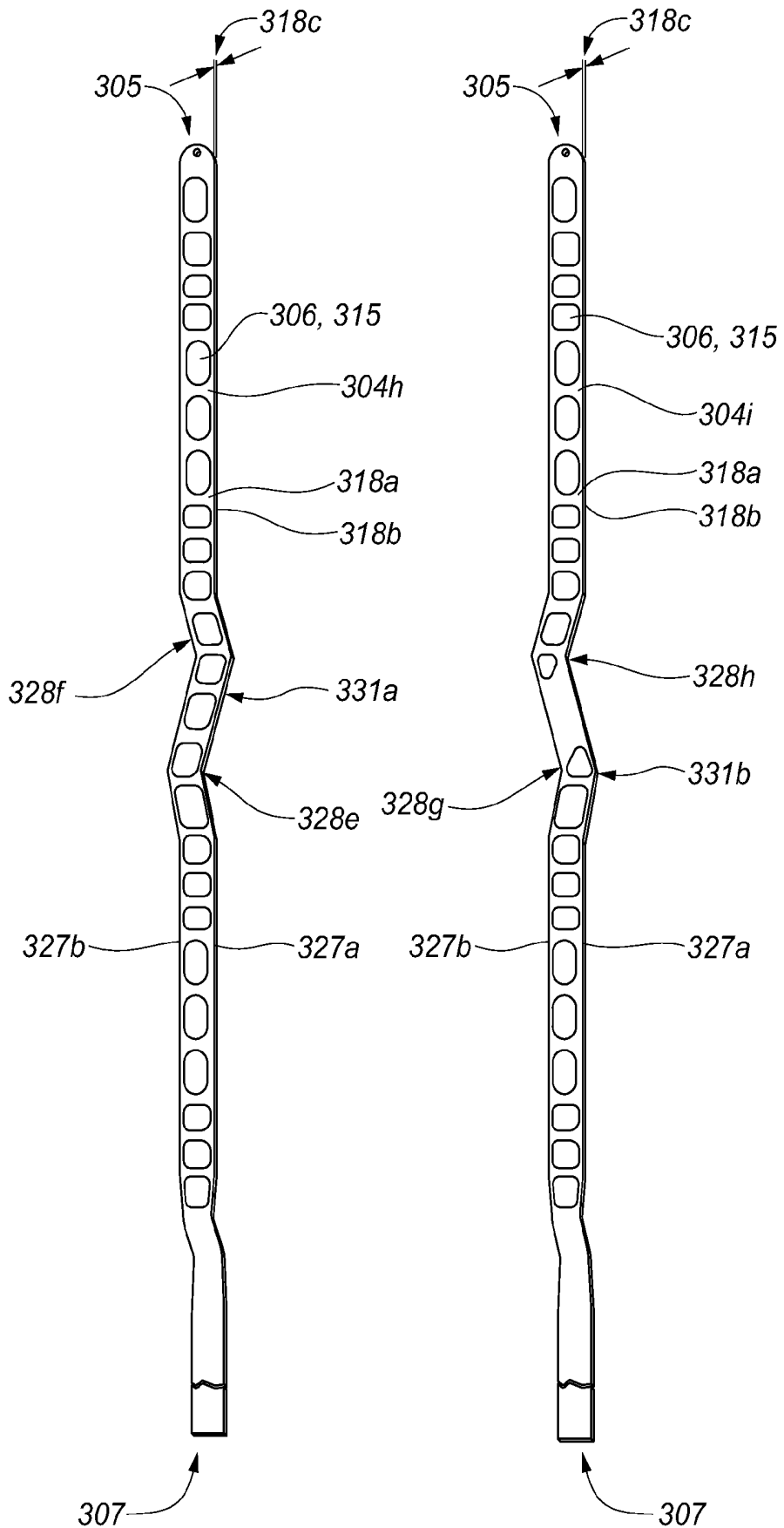

FIG. 3K

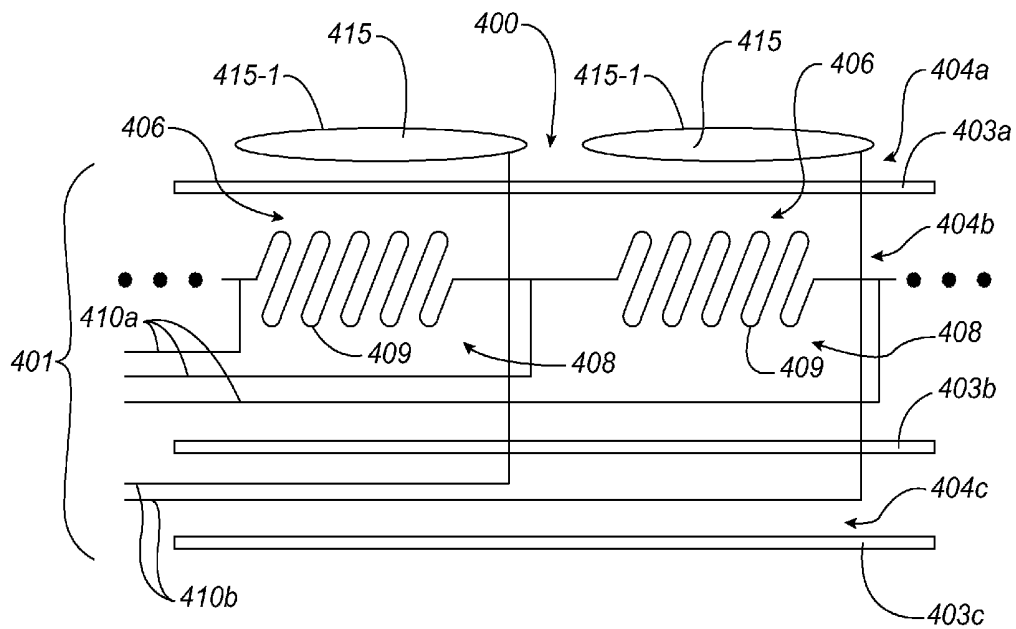

FIG. 4

## HIGH-DENSITY ELECTRODE-BASED MEDICAL DEVICE SYSTEM

### CROSS-REFERENCE TO RELATED APPLICATIONS

This application:

(a) is a continuation-in-part of prior International Application No. PCT/US2012/022061, which has an international filing date of Jan. 20, 2012, and which claims the benefit of each of U.S. Provisional Application No. 61/435,213, filed Jan. 21, 2011; U.S. Provisional Application No. 61/485,987, filed May 13, 2011; U.S. Provisional Application No. 61/488,639, filed May 20, 2011; and U.S. Provisional Application No. 61/515,141, filed Aug. 4, 2011;

(b) is a continuation-in-part of prior International Application No. PCT/US2012/022062, which has an international filing date of Jan. 20, 2012, and which claims the benefit of each of U.S. Provisional Application No. 61/435,213, filed Jan. 21, 2011; U.S. Provisional Application No. 61/485,987, filed May 13, 2011; U.S. Provisional Application No. 61/488,639, filed May 20, 2011; and U.S. Provisional Application No. 61/515,141, filed Aug. 4, 2011; and

(c) claims the benefit of each of U.S. Provisional Application No. 61/649,734, filed May 21, 2012; U.S. Provisional Application No. 61/670,881, filed Jul. 12, 2012; U.S. Provisional Application No. 61/723,311, filed Nov. 6, 2012; and U.S. Provisional Application No. 61/734,750, filed Dec. 7, 2012. The entire disclosure of each of the applications cited in this Cross-Reference to Related Applications Section is hereby incorporated herein by reference.

### TECHNICAL FIELD

Aspects of this disclosure generally are related to a medical device system including a high-density arrangement of transducers. In some embodiments, the transducers are configured to ablate or sense characteristics of tissue inside a bodily cavity.

### BACKGROUND

Cardiac surgery was initially undertaken using highly invasive open procedures. A sternotomy, which is a type of incision in the center of the chest that separates the sternum was typically employed to allow access to the heart. In the past several decades, more and more cardiac operations are performed using intravascular or percutaneous techniques, where access to inner organs or other tissue is gained via a catheter.

Intravascular or percutaneous surgeries benefit patients by reducing surgery risk, complications and recovery time. However, the use of intravascular or percutaneous technologies also raises some particular challenges. Medical devices used in intravascular or percutaneous surgery need to be deployed via catheter systems which significantly increase the complexity of the device structure. As well, doctors do not have direct visual contact with the medical devices once the devices are positioned within the body.

One example of where intravascular or percutaneous medical techniques have been employed is in the treatment of a heart disorder called atrial fibrillation. Atrial fibrillation is a disorder in which spurious electrical signals cause an irregular heartbeat. Atrial fibrillation has been treated with open heart methods using a technique known as the "Cox-Maze procedure". During this procedure, physicians create specific patterns of lesions in the left and right atria to block

various paths taken by the spurious electrical signals. Such lesions were originally created using incisions, but are now typically created by ablating the tissue with various techniques including radio-frequency (RF) energy, microwave energy, laser energy and cryogenic techniques. The procedure is performed with a high success rate under the direct vision that is provided in open procedures, but is relatively complex to perform intravascularly or percutaneously because of the difficulty in creating the lesions in the correct locations. Various problems, potentially leading to severe adverse results, may occur if the lesions are placed incorrectly. It is particularly important to know the position of the various transducers which will be creating the lesions relative to cardiac features such as the pulmonary veins and mitral valve. The continuity, transmural, and placement of the lesion patterns that are formed can impact the ability to block paths taken within the heart by spurious electrical signals. Other requirements for various ones of the transducers to perform additional functions such as, but not limited to, mapping various anatomical features, mapping electrophysiological activity, sensing tissue characteristics such as impedance and temperature and tissue stimulation can also complicate the operation of the employed medical device.

However, conventional transducer-based intra-bodily-cavity devices have relatively few transducers due to conventional technological limitations and, consequently, have difficulty gathering adequate information and performing proper lesion formation. Accordingly, a need in the art exists for improved intra-bodily-cavity transducer-based devices.

### SUMMARY

At least the above-discussed need is addressed and technical solutions are achieved by various embodiments of the present invention. In some embodiments, device systems exhibit enhanced capabilities for the deployment and the activation of various transducers, which may be located within a bodily cavity, such as an intra-cardiac cavity. In some embodiments, systems or a portion thereof may be percutaneously or intravascularly delivered to position the various transducers within the bodily cavity. Various ones of the transducers may be activated to distinguish tissue from blood and may be used to deliver positional information of the device relative to various anatomical features in the bodily cavity, such as the pulmonary veins and mitral valve in an atrium. Various ones of the transducers may employ characteristics such as blood flow detection, impedance change detection or deflection force detection to discriminate between blood and tissue. Various ones of the transducers may be used to treat tissue within a bodily cavity. Treatment may include tissue ablation by way of non-limiting example. Various ones of the transducers may be used to stimulate tissue within the bodily cavity. Stimulation can include pacing by way of non-limiting example. Other advantages will become apparent from the teaching herein to those of skill in the art.

In some embodiments, a medical device system may be summarized as including a structure that includes a plurality of elongate members, each of the elongate members including a proximal end, a distal end, and an intermediate portion between the proximal and distal ends. The medical device system further includes a plurality of electrodes located on the structure, the plurality of electrodes positionable in a bodily cavity. A first group of the electrodes is located on a first elongate member of the plurality of elongate members and a second group of the electrodes is located on a second

elongate member of the plurality of elongate members. The structure is selectively moveable between a delivery configuration in which the structure is sized to be percutaneously delivered to the bodily cavity and a deployed configuration in which the structure is expanded to have a size too large to be percutaneously delivered to the bodily cavity. The intermediate portions of the elongate members are angularly arranged with respect to one another about a first axis when the structure is in the deployed configuration. Each electrode of the first group of the electrodes is intersected by a first plane having no thickness and each electrode of the second group of the electrodes is intersected by a second plane having no thickness when the structure is in the deployed configuration. The first and the second planes are non-parallel planes that intersect each other along a second axis, and at least a first electrode of the plurality of electrodes is intersected by each of the first plane and the second plane when the structure is in the deployed configuration. The first electrode is not intersected by each of the first axis and the second axis when the structure is in the deployed configuration.

In some embodiments, the second axis is parallel to the first axis. In some embodiments, the first axis and the second axis are collinear. In some embodiments, the first axis intersects at least one other electrode of the plurality of electrodes that does not include the first electrode when the structure is in the deployed configuration. In some embodiments, the second axis intersects at least one other electrode of the plurality of electrodes that does not include the first electrode when the structure is in the deployed configuration.

Each of the plurality of elongate members may include a curved portion having a curvature configured to cause the curved portion to extend along at least a portion of a respective curved path, the curvature configured to cause the curved path to intersect the first axis at each of a respective at least two spaced apart locations along the first axis when the structure is in the deployed configuration. At least some of the plurality of electrodes may be radially spaced about the first axis when the structure is in the deployed configuration. At least some of the plurality of electrodes may be circumferentially arranged about the first axis when the structure is in the deployed configuration. The intermediate portion of the first elongate member may overlap the intermediate portion of the second elongate member at a location on the structure passed through by the first axis when the structure is in the deployed configuration. The intermediate portion of the first elongate member may overlap the intermediate portion of the second elongate member at each of a first location on the structure passed through by the first axis and a second location on the structure passed through by the second axis when the structure is in the deployed configuration. Each of the plurality of elongate members may be arranged to be advanced distal end-first into the bodily cavity when the structure is in the delivery configuration. The intermediate portion of the first elongate member may be adjacent the intermediate portion of the second elongate member when the structure is in the deployed configuration.

In some embodiments, the first group of the electrodes may include a pair of adjacent ones of the electrodes located on the first elongate member. A region of space associated with a physical portion of the structure may be located between the respective electrodes of the pair of adjacent ones of the electrodes located on the first elongate member, the region of space intersected by the first plane when the structure is in the deployed configuration. The respective electrodes of the first group of the electrodes may be spaced

along a length of a portion of the first elongate member, the length of the portion of the first elongate member extending along the first elongate member between the proximal and the distal ends of the first elongate member. The entirety of the length of the portion of the elongate member may be intersected by the first plane when the structure is in the deployed configuration. The first group of the electrodes, the second group of the electrodes, or each of both the first and the second groups of the electrodes may include three or more of the plurality of electrodes.

In some embodiments, the first plane may intersect every electrode that is located on the first elongate member when the structure is in the deployed configuration. In some embodiments, the second plane may intersect every electrode that is located on the second elongate member when the structure is in the deployed configuration. In some embodiments, the first group of the electrodes includes the first electrode and the second group of the electrodes does not include the first electrode. At least some of the plurality of electrodes may be arranged in a plurality of concentric ringed arrangements when the structure is in the deployed configuration, a first one of the plurality of concentric ringed arrangements having a fewer number of the electrodes than a second one of the plurality of concentric ringed arrangements. The first one of the plurality of concentric ringed arrangements may include the first electrode.

The first elongate member may include an edge interrupted by a notch, the notch located to expose at least a portion of at least a second electrode located on the second elongate member as viewed towards the second electrode along a direction parallel to a direction that the first axis extends along when the structure is in the deployed configuration. The second group of the electrodes may include the second electrode. The second electrode may be adjacent the first electrode when the structure is in the deployed configuration.

In some embodiments, the first elongate member may include a surface interrupted by a channel, the channel located to expose at least a portion of at least a second electrode located on the second elongate member as viewed towards the second electrode along a direction parallel to a direction that the first axis extends along when the structure is in the deployed configuration. In some embodiments, the first elongate member may include a jogged portion, the jogged portion undergoing at least one change in direction as the jogged portion extends between the proximal and the distal ends of the first elongate member. The jogged portion may be located to expose at least a portion of at least a second electrode located on the second elongate member as viewed towards the second electrode along a direction parallel to a direction that the first axis extends along when the structure is in the deployed configuration. In some embodiments, the intermediate portion of each elongate member of the plurality of elongate members includes a front surface and a back surface opposite across a thickness of the elongate member from the front surface. Each intermediate portion further includes a respective pair of side edges of the front surface, the back surface, or both the front surface and the back surface of the intermediate portion. The side edges of each pair of side edges are opposite to one another, each of the side edges of each pair of side edges extending between the proximal end and the distal end of the respective elongate member. The first elongate member may be positioned such that a first edge of the pair of side edges of the first elongate member crosses a second side edge of the pair of side edges of the second elongate member of the plurality of elongate members when the structure is in the

deployed configuration. A portion of the first edge may form a recessed portion of the first elongate member that exposes at least a portion of a second electrode located on a portion of the front surface of the second elongate member as viewed normally to the portion of the front surface of the second elongate member when the structure is in the deployed configuration. The second group of the electrodes may include the second electrode.

In some embodiments, each of the respective intermediate portions of the elongate members each may include a thickness, a front surface, and a back surface opposite across the thickness from the front surface. The respective intermediate portions of the plurality of elongate members may be arranged front surface-toward-back surface in a stacked array when the structure is in the delivery configuration. The structure may further include a proximal portion and a distal portion, each of the proximal and the distal portions including a respective part of each of the plurality of elongate members, the proximal portion of the structure forming a first domed shape and the distal portion of the structure forming a second domed shape when the structure is in the deployed configuration.

The structure may include a proximal portion and a distal portion with the structure arranged to be advanced distal portion first into the bodily cavity when the structure is in the delivery configuration. In some embodiments, the proximal portion of the structure forms a first domed shape and the distal portion of the structure forms a second domed shape when the structure is in the deployed configuration, the proximal and the distal portions of the structure arranged in a clam shell configuration when the structure is in the deployed configuration.

In some embodiments, the intermediate portions of at least some of the plurality of elongate members are, when the structure is in the deployed configuration, sufficiently spaced from the first axis to position each of at least some of the plurality of the electrodes at respective locations suitable for contact with a tissue wall of the bodily cavity.

Various systems may include combinations and subsets of the systems summarized above.

In some embodiments, a medical device system may be summarized as including a plurality of transducers positionable in a bodily cavity and a structure on which the transducers are located. The structure includes a plurality of elongate members, each of the elongate members including a proximal end, a distal end, an intermediate portion positioned between the proximal end and the distal end, and a thickness. Each intermediate portion includes a front surface and a back surface opposite across the thickness of the elongate member from the front surface, and each intermediate portion further includes a respective pair of side edges of the front surface, the back surface, or both the front surface and the back surface. The side edges of each pair of side edges are opposite to one another, and the side edges of each pair of side edges extend between the proximal end and the distal end of the respective elongate member. The structure is selectively moveable between a delivery configuration in which the structure is sized for percutaneous delivery to a bodily cavity, and a deployed configuration in which the structure is sized too large for percutaneous delivery to the bodily cavity. At least a first elongate member of the plurality of elongate members is positioned such that a first edge of the pair of side edges of the first elongate member crosses a second side edge of the pair of side edges of a second elongate member of the plurality of elongate members when the structure is in the deployed configuration. A portion of the first edge forms a recessed portion of

the first elongate member that exposes at least a portion of a transducer located on a portion of the front surface of the second elongate member as viewed normally to the portion of the front surface of the second elongate member when the structure is in the deployed configuration.

The recessed portion of the first elongate member may form at least a portion of a notch in the intermediate portion of the first elongate member, the notch extending towards a second edge of the pair of side edges of the first elongate member. The first elongate member may include a jogged portion, the jogged portion undergoing at least one change in direction as the jogged portion extends between the proximal and the distal ends of the first elongate member, the recessed portion of the first elongate member forming at least part of the jogged portion.

The intermediate portions of the elongate members may be angularly arranged with respect to one another about an axis when the structure is in the deployed configuration. At least some of the plurality of transducers may be radially spaced about an axis when the structure is in the deployed configuration. At least some of the plurality of transducers may be circumferentially arranged about an axis when the structure is in the deployed configuration. At least some of the plurality of transducers may be arranged in a plurality of concentric ringed arrangements when the structure is in the deployed configuration, a first one of the plurality of concentric ringed arrangements having a fewer number of the transducers than a second one of the plurality of concentric ringed arrangements. The first one of the plurality of concentric ringed arrangements may not include any of the plurality of transducers located on the second elongate member. The second one of the plurality of concentric ringed arrangements may include the transducer located on the portion of the front surface of the second elongate member. The first one of the plurality of concentric ringed arrangements may be adjacent the second one of the plurality of concentric ringed arrangements.

Each of the plurality of elongate members may be arranged to be advanced distal end-first into the bodily cavity when the structure is in the delivery configuration. The respective intermediate portions of the plurality of elongate members may be arranged front surface-toward-back surface in a stacked array when the structure is in the delivery configuration. The structure may further include a proximal portion and a distal portion, each of the proximal and the distal portions including a respective part of each of the plurality of elongate members, the proximal portion of the structure forming a first domed shape and the distal portion of the structure forming a second domed shape when the structure is in the deployed configuration.

The structure may include a proximal portion and a distal portion, with the structure arranged to be advanced distal portion first into the bodily cavity when the structure is in the delivery configuration. In some embodiments, the proximal portion of the structure forms a first domed shape and the distal portion of the structure forms a second domed shape when the structure is in the deployed configuration, the proximal and the distal portions of the structure arranged in a clam shell configuration when the structure is in the deployed configuration.

Various systems may include combinations and subsets of the systems summarized above.

In some embodiments, a medical device system may be summarized as including a plurality of electrodes positionable in a bodily cavity and a structure on which the electrodes are located. The structure includes a plurality of elongate members. The plurality of electrodes include a

plurality of sets of the electrodes, each respective set of the electrodes located on a respective one of the elongate members. Each of the elongate members includes a proximal end, a distal end, an intermediate portion positioned between the proximal end and the distal end, and a thickness. Each intermediate portion includes a front surface and a back surface opposite across the thickness of the elongate member from the front surface. The structure is selectively moveable between a delivery configuration in which the structure is sized for percutaneous delivery to the bodily cavity and a deployed configuration in which the structure is sized too large for percutaneous delivery to the bodily cavity. A first elongate member of the plurality of elongate members is positioned such that a portion of the front surface of the first elongate member overlaps a portion of the respective front surface of each of at least a second elongate member of the plurality of elongate members as viewed normally to the portion of the front surface of the first elongate member when the structure is in the deployed configuration. At least a first electrode of the plurality of electrodes is located at least on the portion of the front surface of the first elongate member, and the portion of the front surface of the second elongate member faces the back surface of the first elongate member at least when the structure is in the deployed configuration.

Each of the front surfaces of the plurality of elongate members may face an outward direction of the structure when the structure is in the deployed configuration. The portion of the front surface of the second elongate member may face the back surface of the first elongate member when the structure is in the delivery configuration. The portion of the front surface of the second elongate member may contact the back surface of the first elongate member when the structure is in the deployed configuration. Each electrode in each set of the plurality of electrodes may be located solely on the front surface of a respective one of the elongate members.

The intermediate portions of the elongate members may be angularly arranged with respect to one another about an axis when the structure is in the deployed configuration. At least some of the plurality of electrodes may be radially spaced about the axis when the structure is in the deployed configuration. At least some of the plurality of electrodes may be circumferentially arranged about the axis when the structure is in the deployed configuration. The intermediate portion of the first elongate member may cross the intermediate portion of the second elongate member at a location on the structure intersected by the axis when the structure is in the deployed configuration. Each of the portion of the front surface of the first elongate member and the portion of the front surface of the second elongate member may be intersected by the axis when the structure is in the deployed configuration. The intermediate portion of the first elongate member may be adjacent the intermediate portion of the second elongate member when the structure is in the deployed configuration. At least one electrode of the plurality of electrodes may be intersected by the axis when the structure is in the deployed configuration. A particular electrode of the at least one electrode may be located adjacently to the first electrode on the portion of the front surface of the first elongate member. At least some of the plurality of electrodes may be arranged in a plurality of concentric ringed arrangements when the structure is in the deployed configuration, a first one of the plurality of concentric ringed arrangements having a fewer number of the electrodes than a second one of the plurality of concentric

ringed arrangements. The first one of the plurality of concentric ringed arrangements may include the first electrode.

Each intermediate portion may further include a respective pair of side edges of the front surface, the back surface, or both the front surface and the back surface of the intermediate portion. The side edges of each pair of side edges are opposite to one another, and each of the side edges of each pair of side edges extend between the proximal end and the distal end of the respective elongate member. The first elongate member may be positioned such that a first edge of the pair of side edges of the first elongate member crosses a second side edge of the pair of side edges of the second elongate member when the structure is in the deployed configuration. A portion of the first edge may form a recessed portion of the first elongate member that exposes at least a portion of a second electrode located on the portion of the front surface of the second elongate member as viewed normally to the portion of the front surface of the second elongate member when the structure is in the deployed configuration.

Each of the plurality of elongate members may be arranged to be advanced distal end-first into the bodily cavity when the structure is in the delivery configuration. The respective intermediate portions of the plurality of elongate members may be arranged front surface-toward-back surface in a stacked array when the structure is in the delivery configuration. The structure may further include a proximal portion and a distal portion, each of the proximal and the distal portions including a respective part of each of the plurality of elongate members. In some embodiments, the proximal portion of the structure forms a first domed shape and the distal portion of the structure forms a second domed shape when the structure is in the deployed configuration.

The structure may include a proximal portion and a distal portion, with the structure arranged to be advanced distal portion first into the bodily cavity when the structure is in the delivery configuration. In some embodiments, the proximal portion of the structure forms a first domed shape and the distal portion of the structure forms a second domed shape when the structure is in the deployed configuration, the proximal and the distal portions of the structure arranged in a clam shell configuration when the structure is in the deployed configuration.

Various systems may include combinations and subsets of the systems summarized above.

In some embodiments, a medical device system may be summarized as including a plurality of electrodes positionable in a bodily cavity and a structure on which the electrodes are located. The structure includes a plurality of elongate members, each of the elongate members including a proximal end, a distal end, an intermediate portion positioned between the proximal end and the distal end, and a thickness. Each intermediate portion includes a front surface and a back surface opposite across the thickness of the elongate member from the front surface. Each intermediate portion further includes a respective pair of side edges of the front surface, the back surface, or both the front surface and the back surface. The side edges of each pair of side edges are opposite to one another. The side edges of each pair of side edges extend between the proximal end and the distal end of the respective elongate member. The structure is selectively moveable between a delivery configuration in which the structure is sized for percutaneous delivery to a bodily cavity and a deployed configuration in which the structure is sized too large for percutaneous delivery to the bodily cavity. At least a first elongate member of the plurality of elongate

members is positioned such that a first side edge of the pair of side edges of the first elongate member crosses a first side edge of the pair of side edges of a second elongate member of the plurality of elongate members at a first location and crosses a second side edge of the pair of side edges of the second elongate member at a second location when the structure is in the deployed configuration. Each of one or more of the plurality of electrodes is wholly located on a portion of the second elongate member, the portion of the second elongate member located between a first transverse line and a second transverse line when the structure is in the deployed configuration, the first transverse line extending across a first width of the second elongate member at the first location, and the second transverse line extending across a second width of the second elongate member at the second location.

The first width may be different than the second width. The first width and the second width may be widths of the front surface of the second elongate member. The one or more electrodes may include two or more of the plurality of electrodes. At least a portion of an electrode of the plurality of electrodes may be located on the portion of the second elongate member.

A first electrode of the one or more of the plurality of electrodes may include a first electrode edge that forms part of a periphery of an electrically conductive surface of the first electrode, the first electrode edge arranged to follow a portion of the first side edge of the first elongate member between the first location and the second location when the structure is in the deployed configuration. The first electrode may include a second electrode edge opposite across the electrically conductive surface from the first electrode edge, the second electrode edge forming part of the periphery of the electrically conductive surface of the first electrode. The second electrode edge may be arranged to follow a portion of one of the pair of side edges of the second elongate member.

The intermediate portions of the elongate members may be angularly arranged with respect to one another about an axis when the structure is in the deployed configuration. At least some of the plurality of electrodes may be radially spaced about the axis when the structure is in the deployed configuration. At least some of the plurality of electrodes may be circumferentially arranged about the axis when the structure is in the deployed configuration. The intermediate portion of the first elongate member may cross the intermediate portion of the second elongate member at a location on the structure intersected by the axis when the structure is in the deployed configuration. The intermediate portion of the first elongate member may be adjacent the intermediate portion of the second elongate member when the structure is in the deployed configuration. A particular one of the plurality of electrodes may be intersected by the axis when the structure is in the deployed configuration. The one or more electrodes may include a first electrode, the first electrode located on the structure adjacent the particular one of the plurality of electrodes when the structure is in the deployed configuration. The one or more electrodes may include a first electrode, and at least some of the plurality of electrodes may be arranged in a plurality of concentric ringed arrangements when the structure is in the deployed configuration. In some embodiments, a first one of the plurality of concentric ringed arrangements has a fewer number of the electrodes than a second one of the plurality of concentric ringed arrangements. The first one of the plurality of concentric ringed arrangements may include the first electrode.

A portion of the first side edge of the first elongate member extending between the first location and the second location may form a recessed portion of the first elongate member that exposes at least a portion of a particular electrode of the one or more electrodes as viewed normally to a surface of the exposed portion of the particular electrode of the one or more electrodes when the structure is in the deployed configuration.

Each of the plurality of elongate members may be arranged to be advanced distal end-first into the bodily cavity when the structure is in the delivery configuration. The respective intermediate portions of the plurality of elongate members may be arranged front surface-toward-back surface in a stacked array when the structure is in the delivery configuration. The structure may further include a proximal portion and a distal portion, each of the proximal and the distal portions including a respective part of each of the plurality of elongate members. In some embodiments, the proximal portion of the structure forms a first domed shape and the distal portion of the structure forms a second domed shape when the structure is in the deployed configuration.

The structure may include a proximal portion and a distal portion, with the structure arranged to be advanced distal portion first into the bodily cavity when the structure is in the delivery configuration. In some embodiments, the proximal portion of the structure forms a first domed shape and the distal portion of the structure forms a second domed shape when the structure is in the deployed configuration, the proximal and the distal portions of the structure arranged in a clam shell configuration when the structure is in the deployed configuration.

Various systems may include combinations and subsets of all the systems summarized above.

#### BRIEF DESCRIPTION OF THE DRAWINGS

It is to be understood that the attached drawings are for purposes of illustrating aspects of various embodiments and may include elements that are not to scale.

FIG. 1 is a schematic representation of a transducer-activation system according to example embodiments, the transducer-activation system including a data processing device system, an input-output device system, and a memory device system.

FIG. 2 is a cutaway diagram of a heart showing a transducer-based device percutaneously placed in a left atrium of the heart according to example embodiments.

FIG. 3A is a partially schematic representation of a medical device system according to example embodiments, the medical device system including a data processing device system, an input-output device system, a memory device system, and a transducer-based device having a plurality of transducers and an expandable structure shown in a delivery or unexpanded configuration.

FIG. 3B is the medical device system of FIG. 3A with the expandable structure shown in a deployed or expanded configuration.

FIG. 3C is a representation of the expandable structure of the medical device system of FIG. 3A in the deployed configuration, as viewed from a different viewing angle than that employed in FIG. 3B.

FIG. 3D is a plan view of the expandable structure of FIG. 3C.

FIG. 3E is an enlarged view of a portion of the expandable structure of FIG. 3D.

FIG. 3F is a representation of an expandable structure of a transducer-based device system according to various example embodiments, the expandable structure in a deployed configuration.

FIG. 3G is a plan view of the expandable structure of FIG. 3F.

FIG. 3H is a perspective view of two of the elongate members of the expandable structure of FIGS. 3F and 3G, each of the elongate members shown in a flattened configuration.

FIG. 3I is an enlarged view of a portion of the expandable structure of FIG. 3G.

FIG. 3J is a plan view of the expandable structure of FIG. 3F with an elongate member of the structure omitted for clarity.

FIG. 3K is a perspective view of two elongate members of an expandable structure of a transducer-based device system according to various embodiments, each of the elongate members shown in a flattened configuration.

FIG. 4 is a schematic representation of a transducer-based device that includes a flexible circuit structure according to at least one example embodiment.

#### DETAILED DESCRIPTION

In the following description, certain specific details are set forth in order to provide a thorough understanding of various embodiments of the invention. However, one skilled in the art will understand that the invention may be practiced without one or more of these details. In other instances, well-known structures (e.g., structures associated with radio-frequency (RF) ablation and electronic controls such as multiplexers) have not been shown or described in detail to avoid unnecessarily obscuring descriptions of various embodiments of the invention.

Reference throughout this specification to “one embodiment” or “an embodiment” or “an example embodiment” or “an illustrated embodiment” or “a particular embodiment” and the like means that a particular feature, structure or characteristic described in connection with the embodiment is included in at least one embodiment. Thus, the appearances of the phrases “in one embodiment” or “in an embodiment” or “in an example embodiment” or “in this illustrated embodiment” or “in this particular embodiment” and the like in various places throughout this specification are not necessarily all referring to the same embodiment. Furthermore, the particular features, structures or characteristics of different embodiments may be combined in any suitable manner to form one or more other embodiments.

It is noted that, unless otherwise explicitly noted or required by context, the word “or” is used in this disclosure in a non-exclusive sense. In addition, unless otherwise explicitly noted or required by context, the word “set” is intended to mean one or more.

Further, the phrase “at least” is used herein at times to emphasize the possibility that other elements can exist besides those explicitly listed. However, unless otherwise explicitly noted (such as by the use of the term “only”) or required by context, non-usage herein of the phrase “at least” does not exclude the possibility that other elements can exist besides those explicitly listed. For example, the phrase, “activation of at least transducer A” includes activation of transducer A by itself, as well as activation of transducer A and activation of one or more other additional elements besides transducer A. In the same manner, the phrase, “activation of transducer A” includes activation of transducer A by itself, as well as activation of transducer A

and activation of one or more other additional elements besides transducer A. However, the phrase, “activation of only transducer A” includes only activation of transducer A, and excludes activation of any other elements besides transducer A.

The word “ablation” as used in this disclosure should be understood to include any disruption to certain properties of tissue. Most commonly, the disruption is to the electrical conductivity and is achieved by heating, which can be generated with resistive or radio-frequency (RF) techniques for example. Other properties, such as mechanical or chemical, and other means of disruption, such as optical, are included when the term “ablation” is used.

The word “fluid” as used in this disclosure should be understood to include any fluid that can be contained within a bodily cavity or can flow into or out of, or both into and out of a bodily cavity via one or more bodily openings positioned in fluid communication with the bodily cavity. In the case of cardiac applications, fluid such as blood will flow into and out of various intra-cardiac cavities (e.g., a left atrium or right atrium).

The words “bodily opening” as used in this disclosure should be understood to include a naturally occurring bodily opening or channel or lumen; a bodily opening or channel or lumen formed by an instrument or tool using techniques that can include, but are not limited to, mechanical, thermal, electrical, chemical, and exposure or illumination techniques; a bodily opening or channel or lumen formed by trauma to a body; or various combinations of one or more of the above. Various elements having respective openings, lumens or channels and positioned within the bodily opening (e.g., a catheter sheath or catheter introducer) may be present in various embodiments. These elements may provide a passageway through a bodily opening for various devices employed in various embodiments.

The words “bodily cavity” as used in this disclosure should be understood to mean a cavity in a body. The bodily cavity may be a cavity provided in a bodily organ (e.g., an intra-cardiac cavity of a heart).

The word “tissue” as used in some embodiments in this disclosure should be understood to include any surface-forming tissue that is used to form a surface of a body or a surface within a bodily cavity, a surface of an anatomical feature or a surface of a feature associated with a bodily opening positioned in fluid communication with the bodily cavity. The tissue can include part or all of a tissue wall or membrane that defines a surface of the bodily cavity. In this regard, the tissue can form an interior surface of the cavity that surrounds a fluid within the cavity. In the case of cardiac applications, tissue can include tissue used to form an interior surface of an intra-cardiac cavity such as a left atrium or right atrium. In some embodiments, the word tissue can refer to a tissue having fluidic properties (e.g., blood).

The term “transducer” as used in this disclosure should be interpreted broadly as any device capable of distinguishing between fluid and tissue, sensing temperature, creating heat, ablating tissue, measuring electrical activity of a tissue surface, stimulating tissue, or any combination thereof. A transducer can convert input energy of one form into output energy of another form. Without limitation, a transducer can include an electrode that functions as, or as part of, a sensing device included in the transducer, an energy delivery device included in the transducer, or both a sensing device and an energy delivery device included in the transducer. A transducer may be constructed from several parts, which may be discrete components or may be integrally formed.

The term “activation” as used in this disclosure should be interpreted broadly as making active a particular function as related to various transducers disclosed in this disclosure. Particular functions can include, but are not limited to, tissue ablation, sensing electrophysiological activity, sensing temperature and sensing electrical characteristics (e.g., tissue impedance). For example, in some embodiments, activation of a tissue ablation function of a particular transducer is initiated by causing energy sufficient for tissue ablation from an energy source device system to be delivered to the particular transducer. Alternatively, in this example, the activation can be deemed to be initiated when the particular transducer causes a temperature sufficient for the tissue ablation due to the energy provided by the energy source device system. Also in this example, the activation can last for a duration of time concluding when the ablation function is no longer active, such as when energy sufficient for the tissue ablation is no longer provided to the particular transducer. Alternatively, in this example, the activation period can be deemed to be concluded when the temperature caused by the particular transducer is below the temperature sufficient for the tissue ablation. In some contexts, however, the word “activation” can merely refer to the initiation of the activating of a particular function, as opposed to referring to both the initiation of the activating of the particular function and the subsequent duration in which the particular function is active. In these contexts, the phrase or a phrase similar to “activation initiation” may be used.

The term “program” in this disclosure should be interpreted as a set of instructions or modules that can be executed by one or more components in a system, such as a controller system or data processing device system, in order to cause the system to perform one or more operations. The set of instructions or modules can be stored by any kind of memory device, such as those described subsequently with respect to the memory device system **130** shown in FIG. 1. In addition, instructions or modules of a program may be described as being configured to cause the performance of a function. The phrase “configured to” in this context is intended to include at least (a) instructions or modules that are presently in a form executable by one or more data processing devices to cause performance of the function (e.g., in the case where the instructions or modules are in a compiled and unencrypted form ready for execution), and (b) instructions or modules that are presently in a form not executable by the one or more data processing devices, but could be translated into the form executable by the one or more data processing devices to cause performance of the function (e.g., in the case where the instructions or modules are encrypted in a non-executable manner, but through performance of a decryption process, would be translated into a form ready for execution). The word “module” can be defined as a set of instructions.

The word “device” and the phrase “device system” both are intended to include one or more physical devices or subdevices (e.g., pieces of equipment) that interact to perform one or more functions, regardless of whether such devices or subdevices are located within a same housing or different housings. In this regard, for example, the phrase “catheter device” could equivalently be referred to as a “catheter device system”.

In some contexts, the term “adjacent” is used in this disclosure to refer to objects that do not have another substantially similar object between them. For example, object A and object B could be considered adjacent if they contact each other (and, thus, it could be considered that no other object is between them), or if they do not contact each

other, but no other object that is substantially similar to object A, object B, or both objects A and B, depending on context, is between them.

Further, the phrase “in response to” might be used in the following context, where an event A occurs in response to the occurrence of an event B. In this regard, such phrase can include, for example, that at least the occurrence of the event B causes or triggers the event A.

FIG. 1 schematically illustrates a system **100** for activating transducers, according to some embodiments. The system **100** includes a data processing device system **110**, an input-output device system **120**, and a processor-accessible memory device system **130**. The processor-accessible memory device system **130** and the input-output device system **120** are communicatively connected to the data processing device system **110**.

The data processing device system **110** includes one or more data processing devices that implement methods by controlling or interacting with various structural components described herein, including, but not limited to, various structural components illustrated in the other FIGS. **2-4**. Each of the phrases “data processing device”, “data processor”, “processor”, and “computer” is intended to include any data processing device, such as a central processing unit (“CPU”), a desktop computer, a laptop computer, a main-frame computer, a tablet computer, a personal digital assistant, a cellular phone, and any other device for processing data, managing data, or handling data, whether implemented with electrical, magnetic, optical, biological components, or otherwise.

The memory device system **130** includes one or more processor-accessible memory devices configured to store information, including the information needed to execute the methods implemented by the data processing device system **110**. The memory device system **130** may be a distributed processor-accessible memory device system including multiple processor-accessible memory devices communicatively connected to the data processing device system **110** via a plurality of computers and/or devices. On the other hand, the memory device system **130** need not be a distributed processor-accessible memory system and, consequently, may include one or more processor-accessible memory devices located within a single housing or data processing device.

Each of the phrases “processor-accessible memory” and “processor-accessible memory device” is intended to include any processor-accessible data storage device, whether volatile or nonvolatile, electronic, magnetic, optical, or otherwise, including but not limited to, registers, floppy disks, hard disks, Compact Discs, DVDs, flash memories, ROMs, and RAMs. In some embodiments, each of the phrases “processor-accessible memory” and “processor-accessible memory device” is intended to include a non-transitory computer-readable storage medium. And in some embodiments, the memory device system **130** can be considered a non-transitory computer-readable storage medium system.

The phrase “communicatively connected” is intended to include any type of connection, whether wired or wireless, between devices, data processors, or programs in which data may be communicated. Further, the phrase “communicatively connected” is intended to include a connection between devices or programs within a single data processor, a connection between devices or programs located in different data processors, and a connection between devices not located in data processors at all. In this regard, although the memory device system **130** is shown separately from the

data processing device system **110** and the input-output device system **120**, one skilled in the art will appreciate that the memory device system **130** may be located completely or partially within the data processing device system **110** or the input-output device system **120**. Further in this regard, although the input-output device system **120** is shown separately from the data processing device system **110** and the memory device system **130**, one skilled in the art will appreciate that such system may be located completely or partially within the data processing system **110** or the memory device system **130**, depending upon the contents of the input-output device system **120**. Further still, the data processing device system **110**, the input-output device system **120**, and the memory device system **130** may be located entirely within the same device or housing or may be separately located, but communicatively connected, among different devices or housings. In the case where the data processing device system **110**, the input-output device system **120**, and the memory device system **130** are located within the same device, the system **100** of FIG. **1** can be implemented by a single application-specific integrated circuit (ASIC) in some embodiments.

The input-output device system **120** may include a mouse, a keyboard, a touch screen, another computer, or any device or combination of devices from which a desired selection, desired information, instructions, or any other data is input to the data processing device system **110**. The input-output device system may include a user-activatable control system that is responsive to a user action. The input-output device system **120** may include any suitable interface for receiving information, instructions or any data from other devices and systems described in various ones of the embodiments. In this regard, the input-output device system **120** may include various ones of other systems described in various embodiments. For example, the input-output device system **120** may include at least a portion of a transducer-based device system. The phrase "transducer-based device system" is intended to include one or more physical systems that include one or more physical devices that include transducers.

The input-output device system **120** also may include an image generating device system, a display device system, a processor-accessible memory device, or any device or combination of devices to which information, instructions, or any other data is output by the data processing device system **110**. In this regard, if the input-output device system **120** includes a processor-accessible memory device, such memory device may or may not form part or all of the memory device system **130**. The input-output device system **120** may include any suitable interface for outputting information, instructions or data to other devices and systems described in various ones of the embodiments. In this regard, the input-output device system may include various other devices or systems described in various embodiments. For example, the input-output device system may include a portion of a transducer-based device system.

Various embodiments of transducer-based devices are described herein. Some of the described devices are medical devices that are percutaneously or intravascularly deployed. Some of the described devices are moveable between a delivery or unexpanded configuration in which a portion of the device is sized for passage through a bodily opening leading to a bodily cavity, and an expanded or deployed configuration in which the portion of the device has a size too large for passage through the bodily opening leading to the bodily cavity. An example of an expanded or deployed configuration is when the portion of the transducer-based

device is in its intended-deployed-operational state inside the bodily cavity. Another example of the expanded or deployed configuration is when the portion of the transducer-based device is being changed from the delivery configuration to the intended-deployed-operational state to a point where the portion of the device now has a size too large for passage through the bodily opening leading to the bodily cavity.

In some example embodiments, the device includes transducers that sense characteristics (e.g., convective cooling, permittivity, force) that distinguish between fluid, such as a fluidic tissue (e.g., blood), and tissue forming an interior surface of the bodily cavity. Such sensed characteristics can allow a medical device system to map the cavity, for example using positions of openings or ports into and out of the cavity to determine a position or orientation (i.e., pose), or both of the portion of the device in the bodily cavity. In some example embodiments, the described devices are capable of ablating tissue in a desired pattern within the bodily cavity. In some example embodiments, the devices are capable of sensing characteristics (e.g., electrophysiological activity) indicative of whether an ablation has been successful. In some example embodiments, the devices are capable of providing stimulation (e.g., electrical stimulation) to tissue within the bodily cavity. Electrical stimulation may include pacing.

FIG. **2** shows a transducer-based device **200**, which may be all or part of a medical device system, useful in investigating or treating a bodily organ, for example a heart **202**, according to some example embodiments.

Transducer-based device **200** can be percutaneously or intravascularly inserted into a portion of the heart **202**, such as an intra-cardiac cavity like left atrium **204**. In this example, the transducer-based device **200** is part of a catheter **206** inserted via the inferior vena cava **208** and penetrating through a bodily opening in transatrial septum **210** from right atrium **212**. In other embodiments, other paths may be taken.

Catheter **206** includes an elongated flexible rod or shaft member appropriately sized to be delivered percutaneously or intravascularly. Various portions of catheter **206** may be steerable. Catheter **206** may include one or more lumens (not shown). The lumen(s) may carry one or more communications or power paths, or both. For example, the lumens(s) may carry one or more electrical conductors **216** (two shown in this embodiment). Electrical conductors **216** provide electrical connections to device **200** that are accessible externally from a patient in which the transducer-based device **200** is inserted.

Transducer-based device **200** includes a frame or structure **218** which assumes an unexpanded configuration for delivery to left atrium **204**. Structure **218** is expanded (i.e., shown in a deployed or expanded configuration in FIG. **2**) upon delivery to left atrium **204** to position a plurality of transducers **220** (three called out in FIG. **2**) proximate the interior surface formed by tissue **222** of left atrium **204**. In some embodiments, at least some of the transducers **220** are used to sense a physical characteristic of a fluid (i.e., blood) or tissue **222**, or both, that may be used to determine a position or orientation (i.e., pose), or both, of a portion of a device **200** within, or with respect to left atrium **204**. For example, transducers **220** may be used to determine a location of pulmonary vein ostia (not shown) or a mitral valve **226**, or both. In some embodiments, at least some of the transducers **220** may be used to selectively ablate portions of the tissue **222**. For example, some of the transducers **220** may be used to ablate a pattern or path around various ones of the bodily

openings, ports or pulmonary vein ostia, for instance to reduce or eliminate the occurrence of atrial fibrillation.

FIGS. 3A, 3B, 3C, 3D and 3E show a transducer-based device system (i.e., a portion thereof shown schematically) that includes a transducer-based device 300 according to one 5 illustrated embodiment. Transducer-based device 300 includes a plurality of elongate members 304 (three called out in each of FIGS. 3A and 3B, and three are called out in each of FIGS. 3C, 3D and 3E as 304a, 304b and 304c) and a plurality of transducers 306 (three called out in FIG. 3A, 10 three called out in FIG. 3B as 306a, 306b and 306c, and seven called out in each of FIGS. 3C and 3D, six of the seven identified as 306q, 306r, 306s, 306t, 306u and 306v). As will become apparent, the plurality of transducers 306 are positionable within a bodily cavity. For example, in some 15 embodiments, the transducers 306 are able to be positioned in a bodily cavity by movement into, within, or into and within the bodily cavity, with or without a change in a configuration of the plurality of transducers 306. In some embodiments, the plurality of transducers 306 are arrange- 20 able to form a two- or three-dimensional distribution, grid or array of the transducers capable of mapping, ablating or stimulating an inside surface of a bodily cavity or lumen without requiring mechanical scanning. As shown for example, in FIG. 3A, the plurality of transducers 306 are arranged in a distribution receivable in a bodily cavity (not shown in FIG. 3A). As shown for example, in FIG. 3A, the plurality of transducers 306 are arranged in a distribution suitable for delivery to a bodily cavity (not shown in FIG. 3A). (It should also be noted, for example, that the expanded or deployed configuration (e.g., FIGS. 2, 3B-3G, 3I, and 3J) also provide transducers 306 arranged in a distribution receivable in a bodily cavity.)

The elongate members 304 are arranged in a frame or structure 308 that is selectively movable between an unex- 35 panded or delivery configuration (i.e., as shown in FIG. 3A) and an expanded or deployed configuration (i.e., as shown in FIG. 3B) that may be used to position elongate members 304 against a tissue surface within the bodily cavity or position the elongate members 304 in the vicinity of or in contact 40 with the tissue surface. In some embodiments, structure 308 has a size in the unexpanded or delivery configuration suitable for percutaneous delivery through a bodily opening (i.e., via catheter sheath 312, not shown in FIG. 3B) to the bodily cavity. In some embodiments, structure 308 has a size 45 in the expanded or deployed configuration too large for percutaneous delivery through a bodily opening (i.e., via catheter sheath 312) to the bodily cavity. The elongate members 304 may form part of a flexible circuit structure (i.e., also known as a flexible printed circuit board (PCB) 50 circuit). The elongate members 304 can include a plurality of different material layers, and each of the elongate members 304 can include a plurality of different material layers. The structure 308 can include a shape memory material, for instance Nitinol. The structure 308 can include a metallic 55 material, for instance stainless steel, or non-metallic material, for instance polyimide, or both a metallic and non metallic material by way of non-limiting example. The incorporation of a specific material into structure 308 may be motivated by various factors including the specific requirements of each of the unexpanded or delivery con- 60 figuration and expanded or deployed configuration, the required position or orientation (i.e., pose) or both of structure 308 in the bodily cavity, or the requirements for successful ablation of a desired pattern.

FIG. 4 is a schematic side elevation view of at least a portion of a transducer-based device 400 that includes a

flexible circuit structure 401 that is employed to provide a plurality of transducers 406 (two called out) according to an example embodiment. In some embodiments, the flexible circuit structure 401 may form part of a structure (e.g., structure 308) that is selectively movable between a delivery configuration sized for percutaneous delivery and expanded or deployed configurations sized too large for percutaneous delivery. In some embodiments, the flexible circuit structure 401 may be located on, or form at least part of, of a structural component (e.g., elongate member 304) of a transducer-based device system.

The flexible circuit structure 401 can be formed by various techniques including flexible printed circuit techniques. In some embodiments, the flexible circuit structure 401 includes various layers including flexible layers 403a, 403b and 403c (i.e., collectively flexible layers 403). In some embodiments, each of flexible layers 403 includes an electrical insulator material (e.g., polyimide). One or more of the flexible layers 403 can include a different material than another of the flexible layers 403. In some embodi- 20 ments, the flexible circuit structure 401 includes various electrically conductive layers 404a, 404b and 404c (collectively electrically conductive layers 404) that are interleaved with the flexible layers 403. In some embodiments, each of the electrically conductive layers 404 is patterned to form various electrically conductive elements. For example, electrically conductive layer 404a is patterned to form a respec- 35 tive electrode 415 of each of the transducers 406. Electrodes 415 have respective electrode edges 415-1 that form a periphery of an electrically conductive surface associated with the respective electrode 415. FIG. 3C shows another example of electrode edges 315-1 and illustrates that the electrode edges can define electrically-conductive-surface- 40 peripheries of various shapes.

Returning to FIG. 4, electrically conductive layer 404b is 45 patterned, in some embodiments, to form respective temperature sensors 408 for each of the transducers 406 as well as various leads 410a arranged to provide electrical energy to the temperature sensors 408. In some embodiments, each temperature sensor 408 includes a patterned resistive member 409 (two called out) having a predetermined electrical resistance. In some embodiments, each resistive member 409 includes a metal having relatively high electrical conductivity characteristics (e.g., copper). In some embodi- 50 ments, electrically conductive layer 404c is patterned to provide portions of various leads 410b arranged to provide an electrical communication path to electrodes 415. In some embodiments, leads 410b are arranged to pass through vias (not shown) in flexible layers 403a and 403b to connect with electrodes 415. Although FIG. 4 shows flexible layer 403c as being a bottom-most layer, some embodiments may include one or more additional layers underneath flexible layer 403c, such as one or more structural layers, such as a steel or composite layer. These one or more structural layers, in some embodiments, are part of the flexible circuit structure 401 and can be part of, e.g., elongate member 304. In addition, although FIG. 4 shows only three flexible layers 403a-403c and only three electrically conductive layers 404a-404c, it should be noted that other numbers of flexible 60 layers, other numbers of electrically conductive layers, or both, can be included.

In some embodiments, electrodes 415 are employed to selectively deliver RF energy to various tissue structures within a bodily cavity (not shown) (e.g., an intra-cardiac cavity). The energy delivered to the tissue structures may be sufficient for ablating portions of the tissue structures. The energy delivered to the tissue may be delivered to cause

monopolar tissue ablation, bipolar tissue ablation or blended monopolar-bipolar tissue ablation by way of non-limiting example. In some embodiments, each electrode 415 is employed to sense an electrical potential in the tissue proximate the electrode 415. In some embodiments, each electrode 415 is employed in the generation of an intra-cardiac electrogram. In some embodiments, each resistive member 409 is positioned adjacent a respective one of the electrodes 415. In some embodiments, each of the resistive members 409 is positioned in a stacked or layered array with a respective one of the electrodes 415 to form a respective one of the transducers 406. In some embodiments, the resistive members 409 are connected in series to allow electrical current to pass through all of the resistive members 409. In some embodiments, leads 410a are arranged to allow for a sampling of electrical voltage in between each resistive members 409. This arrangement allows for the electrical resistance of each resistive member 409 to be accurately measured. The ability to accurately measure the electrical resistance of each resistive member 409 may be motivated by various reasons including determining temperature values at locations at least proximate the resistive member 409 based at least on changes in the resistance caused by convective cooling effects (e.g., as provided by blood flow). In some embodiments in which the transducer-based device is deployed in a bodily cavity (e.g., when the transducer-based device takes the form of a catheter device arranged to be percutaneously or intravascularly delivered to a bodily cavity), it may be desirable to perform various mapping procedures in the bodily cavity. For example, when the bodily cavity is an intra-cardiac cavity, a desired mapping procedure can include mapping electrophysiological activity in the intra-cardiac cavity. Other desired mapping procedures can include mapping of various anatomical features within a bodily cavity. An example of the mapping performed by devices according to various embodiments may include locating the position of the ports of various bodily openings positioned in fluid communication with a bodily cavity. For example, in some embodiments, it may be desired to determine the locations of various ones of the pulmonary veins or the mitral valve that each interrupts an interior surface of an intra-cardiac cavity such as a left atrium.

In some example embodiments, the mapping is based at least on locating bodily openings by differentiating between fluid and tissue (e.g., tissue defining a surface of a bodily cavity). There are many ways to differentiate tissue from a fluid such as blood or to differentiate tissue from a bodily opening in case a fluid is not present. Four approaches may include by way of non-limiting example:

1. The use of convective cooling of heated transducer elements by fluid. An arrangement of slightly heated transducers that is positioned adjacent to the tissue that forms the interior surface(s) of a bodily cavity and across the ports of the bodily cavity will be cooler at the areas which are spanning the ports carrying the flow of fluid.

2. The use of tissue impedance measurements. A set of transducers positioned adjacently to tissue that forms the interior surface(s) of a bodily cavity and across the ports of the bodily cavity can be responsive to electrical tissue impedance. Typically, heart tissue will have higher associated tissue impedance values than the impedance values associated with blood.

3. The use of the differing change in dielectric constant as a function of frequency between blood and tissue. A set of transducers positioned around the tissue that forms the interior surface(s) of the atrium and across the ports of the

atrium monitors the ratio of the dielectric constant from 1 KHz to 100 KHz. Such can be used to determine which of those transducers are not proximate to tissue, which is indicative of the locations of the ports.

4. The use of transducers that sense force (i.e., force sensors). A set of force detection transducers positioned around the tissue that forms the interior surface(s) of a bodily cavity and across the bodily openings or ports of the bodily cavity can be used to determine which of the transducers are not engaged with the tissue, which may be indicative of the locations of the ports.

Referring to FIGS. 3A, 3B, transducer-based device 300 can communicate with, receive power from or be controlled by a transducer-activation system 322. In some embodiments, elongate members 304 can form a portion of an elongated cable 316 of control leads 317, for example by stacking multiple layers, and terminating at a connector 321 or other interface with transducer-activation system 322. The control leads 317 may correspond to the electrical connectors 216 in FIG. 2 in some embodiments. The transducer-activation device system 322 may include a controller 324 that includes a data processing device system 310 (e.g., from FIG. 1) and a memory device system 330 (e.g., from FIG. 1) that stores data and instructions that are executable by the data processing device system 310 to process information received from transducer-based device 300 or to control operation of transducer-based device 300, for example activating various selected transducers 306 to ablate tissue. Controller 324 may include one or more controllers.

Transducer-activation device system 322 includes an input-output device system 320 (e.g., an example of 120 from FIG. 1) communicatively connected to the data processing device system 310 (i.e., via controller 324 in some embodiments). Input-output device system 320 may include a user-activatable control that is responsive to a user action. Input-output device system 320 may include one or more user interfaces or input/output (I/O) devices, for example one or more display device systems 332, speaker device systems 334, keyboards, mice, joysticks, track pads, touch screens or other transducers to transfer information to, from, or both to and from a user, for example a care provider such as a physician or technician. For example, output from a mapping process may be displayed on a display device system 332.

Transducer-activation device system 322 may also include an energy source device system 340 including one or more energy source devices connected to transducers 306. In this regard, although FIG. 3A shows a communicative connection between the energy source device system 340 and the controller 324 (and its data processing device system 310), the energy source device system 340 may also be connected to the transducers 306 via a communicative connection that is independent of the communicative connection with the controller 324 (and its data processing device system 310). For example, the energy source device system 340 may receive control signals via the communicative connection with the controller 324 (and its data processing device system 310), and, in response to such control signals, deliver energy to, receive energy from, or both deliver energy to and receive energy from one or more of the transducers 306 via a communicative connection with such transducers 306 (e.g., via one or more communication lines through catheter body 314, elongated cable 316 or catheter sheath 312) that does not pass through the controller 324. In this regard, the energy source device system 340 may provide results of its delivering energy to, receiving energy

from, or both delivering energy to and receiving energy from one or more of the transducers 306 to the controller 324 (and its data processing device system 310) via the communicative connection between the energy source device system 340 and the controller 324.

In any event, the number of energy source devices in the energy source device system 340 is fewer than the number of transducers in some embodiments. The energy source device system 340 may, for example, be connected to various selected transducers 306 to selectively provide energy in the form of electrical current or power (e.g., RF energy), light or low temperature fluid to the various selected transducers 306 to cause ablation of tissue. The energy source device system 340 may, for example, selectively provide energy in the form of electrical current to various selected transducers 306 and measure a temperature characteristic, an electrical characteristic, or both at a respective location at least proximate each of the various transducers 306. The energy source device system 340 may include as its energy source devices various electrical current sources or electrical power sources. In some embodiments, an indifferent electrode 326 is provided to receive at least a portion of the energy transmitted by at least some of the transducers 306. Consequently, although not shown in FIG. 3A, the indifferent electrode 326 may be communicatively connected to the energy source device system 340 via one or more communication lines in some embodiments. In addition, although shown separately in FIG. 3A, indifferent electrode 326 may be considered part of the energy source device system 340 in some embodiments.

It is understood that input-output device system 320 may include other systems. In some embodiments, input-output device system 320 may optionally include energy source device system 340, transducer-based device 300 or both energy source device system 340 and transducer-based device 300 by way of non-limiting example.

Structure 308 can be delivered and retrieved via a catheter member, for example a catheter sheath 312. In some embodiments, a structure provides expansion and contraction capabilities for a portion of a medical device (e.g., an arrangement, distribution or array of transducers 306). The transducers 306 can form part of, be positioned or located on, mounted or otherwise carried on the structure and the structure may be configurable to be appropriately sized to slide within catheter sheath 312 in order to be deployed percutaneously or intravascularly. FIG. 3A shows one embodiment of such a structure. In some embodiments, each of the elongate members 304 includes a respective distal end 305 (only one called out), a respective proximal end 307 (only one called out) and an intermediate portion 309 (only one called out) positioned between the proximal end 307 and the distal end 305. The respective intermediate portion 309 of each elongate member 304 includes a first or front surface 318a that is positionable to face an interior tissue surface within a bodily cavity (not shown) and a second or back surface 318b opposite across a thickness of the intermediate portion 309 from the front surface 318a. In various embodiments, the intermediate portion 309 of each of the elongate members 304 includes a respective pair of side edges of the front surface 318a, the back surface 318b, or both the front surface 318a and the back surface 318b, the side edges of each pair of side edges opposite to one another, the side edges of each pair of side edges extending between the proximal end 307 and the distal end 305 of the respective elongate member 304. In some embodiments, each pair of side edges includes a first side edge 327a (only one called out in FIG. 3A) and a second side edge 327b (only one called

out in FIG. 3A). In some embodiments, each of the elongate members 304, including each respective intermediate portion 309, is arranged front surface 318a-toward-back surface 318b in a stacked array during an unexpanded or delivery configuration similar to that described in co-assigned International Application No.: PCT/US2012/022061 and co-assigned International Application No.: PCT/US2012/022062. In many cases a stacked array allows the structure 308 to have a suitable size for percutaneous or intravascular delivery. In some embodiments, the elongate members 304 are arranged to be introduced into a bodily cavity (again not shown in FIG. 3A) distal end 305 first. For clarity, not all of the elongate members 304 of structure 308 are shown in FIG. 3A. A flexible catheter body 314 is used to deliver structure 308 through catheter sheath 312. In some embodiments, each elongate member includes a twisted portion proximate at proximal end 307. Similar twisted portions are described in co-assigned International Application No.: PCT/US2012/022061 and co-assigned International Application No.: PCT/US2012/022062.

In a manner similar to that described in co-assigned International Application No.: PCT/US2012/022061 and co-assigned International Application No.: PCT/US2012/022062, each of the elongate members 304 is arranged in a fanned arrangement 370 in FIG. 3B. In some embodiments, the fanned arrangement 370 is formed during the expanded or deployed configuration in which structure 308 is manipulated to have a size too large for percutaneous or intravascular delivery. In some embodiments, structure 308 includes a proximal portion 308a having a first domed shape 309a and a distal portion 308b having a second domed shape 309b. In some embodiments, the proximal and the distal portions 308a, 308b include respective portions of elongate members 304. In some embodiments, the structure 308 is arranged to be delivered distal portion 308b first into a bodily cavity (again not shown) when the structure is in the unexpanded or delivery configuration as shown in FIG. 3A. In some embodiments, the proximal and the distal portions 308a, 308b are arranged in a clam shell configuration in the expanded or deployed configuration shown in FIG. 3B. In various example embodiments, each of the front surfaces 318a (three called out in FIG. 3B) of the intermediate portions 309 of the plurality of elongate members 304 face outwardly from the structure 308 when the structure 308 is in the deployed configuration. In various example embodiments, each of the front surfaces 318a of the intermediate portions 309 of the plurality of elongate members 304 are positioned adjacent an interior tissue surface of a bodily cavity (not shown) in which the structure 308 (i.e., in the deployed configuration) is located. In various example embodiments, each of the back surfaces 318b (two called out in FIG. 3B) of the intermediate portions 309 of the plurality of elongate members 304 face an inward direction when the structure 308 is in the deployed configuration.

The transducers 306 can be arranged in various distributions or arrangements in various embodiments. In some embodiments, various ones of the transducers 306 are spaced apart from one another in a spaced apart distribution in the delivery configuration shown in FIG. 3A. In some embodiments, various ones of the transducers 306 are arranged in a spaced apart distribution in the deployed configuration shown in FIG. 3B. In some embodiments, various pairs of transducers 306 are spaced apart with respect to one another. In some embodiments, various regions of space are located between various pairs of the transducers 306. For example, in FIG. 3B the transducer-based device 300 includes at least a first transducer 306a, a

second transducer **306b** and a third transducer **306c** (all collectively referred to as transducers **306**). In some embodiments each of the first, the second, and the third transducers **306a**, **306b** and **306c** are adjacent transducers in the spaced apart distribution. In some embodiments, the first and the second transducers **306a**, **306b** are located on different elongate members **304** while the second and the third transducers **306b**, **306c** are located on a same elongate member **304**. In some embodiments, a first region of space **350** is between the first and the second transducers **306a**, **306b**. In some embodiments, the first region of space **350** is not associated with any physical portion of structure **308**. In some embodiments, a second region of space **360** associated with a physical portion of device **300** (i.e., a portion of an elongate member **304**) is between the second and the third transducers **306b**, **306c**. In some embodiments, each of the first and the second regions of space **350**, **360** does not include a transducer of transducer-based device **300**. In some embodiments, each of the first and the second regions of space **350**, **360** does not include any transducer. It is noted that other embodiments need not employ a group of elongate members **304** as employed in the illustrated embodiment. For example, other embodiments may employ a structure having one or more surfaces, at least a portion of the one or more surfaces defining one or more openings in the structure. In these embodiments, a region of space not associated with any physical portion of the structure may extend over at least part of an opening of the one or more openings. In other example embodiments, other structures may be employed to support or carry transducers of a transducer-based device such as a transducer-based catheter. For example, an elongated catheter member may be used to distribute the transducers in a linear or curvilinear array. Basket catheters or balloon catheters may be used to distribute the transducers in a two-dimensional or three-dimensional array.

In various example embodiments, at least some of the plurality of transducers **306** include respective electrodes **315** (seven called out in each of FIGS. **3C**, **3D**, six of the seven called out as **315q**, **315r**, **315s**, **315t**, **315u** and **315v**), each electrode **315** including a respective energy transmission surface **319** (one called out in FIG. **3C**, three called out in FIG. **3D**, two of the three called out as **319u**, **319v**) configured for transferring energy to tissue, from tissue or both to and from tissue. In various embodiments, each of the energy transmission surfaces **319** is provided by an electrically conductive surface. In some embodiments, each of the electrodes **315** is solely located on a surface of an elongate member **304** (e.g., front surfaces **318a** or back surfaces **318b**). In some embodiments, various electrodes **315** are located on one, but not both of the respective front surface **318a** and respective back surface **318b** of each of various ones of the elongate members **304**.

Various conventional percutaneous or intravascular transducer-based device systems employ, or have employed, relatively low numbers of transducers typically on the order of 64 or fewer transducers or a number of transducers arranged with a relatively low spatial distribution density (e.g., a relatively low number of transducers arranged per a given area). Various embodiments disclosed in this detailed description may employ distributions of transducers having relatively high spatial densities (e.g., a relatively high number of transducers arranged per a given region of space) than conventionally employed. Increased number of transducers or increased spatial densities of transducers within a particular distribution of the transducers may be motivated for various reasons. For example, increased numbers of trans-

ducers may allow for higher spatial densities in the distributions of the transducers to allow the transducers to interact with a tissue region of a bodily cavity with greater resolution and accuracy. The interactions may include ablation, temperature detection, impedance detection, electrophysiological activity detection and tissue stimulation by way of non-limiting example. In some case, distributions of transducers having relatively high spatial densities may provide enhanced diagnostic or treatment procedures performed on a given tissue region by allowing for the interaction of a greater number of transducers with the given tissue region. Various embodiments disclosed in this detailed description may employ 100 or more transducers, 200 or more transducers or even 300 or more transducers. Various transducer-based devices disclosed in this detailed description (e.g., as depicted at least in part in FIGS. **3A**, **3B**, **3C**, **3D**, **3E**, **3F**, **3G**, **3H**, **3I**, **3J** and **3K**) are representative of various embodiments that employ several hundreds of transducers. Various transducer-based devices disclosed in this detailed description (e.g., as depicted at least in part in FIGS. **3A**, **3B**, **3C**, **3D**, **3E**, **3F**, **3G**, **3H**, **3I**, **3J** and **3K**) are representative of various embodiments that employ distributions of transducers having relatively higher spatial densities. Although transducers **306**, electrodes **315** or both transducers **306** and electrodes **315** are referenced with respect to various embodiments, it is understood that other transducers or transducer elements may be employed in other embodiments. It is understood that a reference to a particular transducer **306** in various embodiments may also imply a reference to an electrode **315**, as an electrode **315** may be part of the transducer **306** as shown, e.g., with FIG. **4**.

FIG. **3C** is a perspective view of at least one embodiment of the transducer-based device **300** as viewed from a viewing angle that is different from that shown in FIG. **3B**. For clarity of illustration, only structure **308** including various ones of the elongate members **304**, and a portion of catheter body **314** are shown in FIG. **3C**. In a manner similar to that shown in FIG. **3B**, transducer-based device **300** is shown in the expanded or deployed configuration. In some embodiments, the respective intermediate portions **309** (only two called out) of various ones of the elongate members **304** are angularly arranged with respect to one another about a first axis **335a** when structure **308** is in the deployed configuration. In various embodiments, the respective intermediate portions **309** of a respective pair of the elongate members **304** are angularly spaced with respect to one another by a respective angle radiating from a point on the first axis **335a** when structure **308** is in the deployed configuration. The same may apply for each pair of adjacent elongate members **304** in some embodiments. In various embodiments, the intermediate portions **309** of various ones of the elongate members **304** are radially arranged about first axis **335a** when structure **308** is in the deployed configuration. In various embodiments, the intermediate portions **309** of various ones of the elongate members **304** are circumferentially arranged about first axis **335a** when structure **308** is in the deployed configuration, similar to lines of longitude about an axis of rotation of a body of revolution, which body of revolution may, or may not be spherical. Use of the word circumference in this detailed description, and derivatives thereof, such as circumferential, circumscribe, circumlocutory and other derivatives, refers to a boundary line of a shape, volume or object which may, or may not, be circular or spherical. In some embodiments, each of the elongate members **304** includes a curved portion **323** (only two called out) having a curvature configured to cause the curved portion **323** to extend along at least a portion of a curved

path, the curvature configured to cause the curved path to intersect the first axis **335a** at each of a respective at least two spaced apart locations along the first axis **335a** when structure **308** is in the deployed configuration. In some embodiments, the curved path is defined to include an imagined extension of the curved portion along the curved portion's extension direction while maintaining the curved portion's curvature. In some embodiments, each curved portion **323** may extend entirely along, or at least part way along the respective curved path to physically intersect at least one of the respective at least two spaced apart locations along the first axis **335a**. In some particular embodiments, no physical portion of a given elongate member of an employed structure intersects any of the at least two spaced apart locations along the first axis **335a** intersected by the respective curved path associated with the curved portion **323** of the given elongate member. For example, the end portion of the given elongate member may be physically separated from the first axis **335a** by hub system (not shown) employed to physically couple or align the elongate member to other elongate members. Additionally or alternatively, a given elongate member may include a recurve portion arranged to physically separate the given elongate member from the first axis **335a**. In some embodiments, various ones of the elongate members **304** cross one another at a location on the structure **308** passed through by the first axis **335a** when the structure **308** is in the deployed configuration. In various embodiments, the curved path is an arcuate path. In various embodiments, at least the portion of the curved path extended along by corresponding curved portion **323** is arcuate. As used herein, the word "curvature" should be understood to mean a measure or amount of curving. In some embodiments, the word "curvature" is associated with a rate of change of the angle through which the tangent to a curve turns in moving along the curve.

In some embodiments, the intermediate portion **309** of first elongate member **304a** overlaps the intermediate portion **309** of a second elongate member **304b** at a location on structure **308** passed through by first axis **335a** when structure **308** is in the deployed configuration. In some embodiments, the intermediate portions **309** of the first elongate member **304a** and the second elongate member **304b** cross at a location on structure **308** passed through, or intersected, by first axis **335a** when structure **308** is in the deployed configuration. In some embodiments, the intermediate portion **309** of first elongate member **304a** is adjacent the intermediate portion **309** of the second elongate member **304b** when structure **308** is in the deployed configuration. In various embodiments, the intermediate portions **309** of at least some of the plurality of elongate members **304** are, when the structure **309** is in the deployed configuration, sufficiently spaced from the first axis **335a** to position each of at least some of the plurality of the electrodes **315** at respective locations suitable for contact with a tissue wall of the bodily cavity (not shown in FIG. 3C). In various embodiments, at least some of the transducers **306** are radially spaced about first axis **335a** when structure **308** is in the deployed configuration. For example, various ones of the electrodes **315** are radially spaced about first axis **335a** in the deployed configuration in at least some of the embodiments associated with various ones of FIGS. 3B, 3C, 3D and 3E. In various embodiments, at least some of the transducers **306** are circumferentially arranged about first axis **335a** when structure **308** is in the deployed configuration. For example, various ones of the electrodes **315** are circumferentially arranged about first axis **335a** in the deployed configuration in at least some of the embodiments associated with various

ones of FIGS. 3B, 3C, 3D and 3E. Various methods may be employed to describe the various spatial relationships of the transducers **306** or electrodes **315** or various sets of transducers **306** or sets of electrodes **315** employed according to various embodiments. For example, in FIGS. 3C and 3D the plurality of the electrodes **315** includes a first group **336a** (not called out in FIG. 3E) of the electrodes **315** located on first elongate member **304a** and a second group **338a** (not called out in FIG. 3E) of the electrodes **315** located on second elongate member **304b**. It is understood that although electrodes are referred to in these described embodiments, the same analysis applies to the corresponding transducers in some embodiments. It is understood that although groups of electrodes are referred to in these described embodiments, the plurality of electrodes **315** may form part of a plurality of sets of one or more of the electrodes **315**, each respective set of the electrodes **315** located on a respective one of the elongate members **304** in other embodiments. The electrodes **315** of the first group **336a** are arranged such that each electrode **315** of the first group **336a** is intersected by a first plane **342a** having no thickness. The phrase "no thickness" in this and similar contexts means no thickness, practically no thickness, or infinitely small thickness, and excludes perceptibly large thicknesses like thicknesses on the order of a size of an electrode **315**. The electrodes **315** of the second group **338a** are arranged such that each electrode **315** of the second group **338a** is intersected by a second plane **344a** having no thickness. For clarity, the intersection of each electrode **315** of the first group **336a** by first plane **342a** is represented in FIG. 3C by intersection line **345a**. For clarity, the intersection of each electrode **315** of the second group **338a** by second plane **344a** is represented in FIG. 3C by intersection line **345b**. First plane **342a** and second plane **344a** are depicted as having boundaries merely for purposes of clarity of illustration in FIG. 3C.

Each of the first plane **342a** and the second plane **344a** are non-parallel planes that intersect each other along a second axis **337a**. In some embodiments, second axis **337a** is parallel to first axis **335a**. In some embodiments, first axis **335a** and second axis **337a** are collinear. In some embodiments, the first axis **335a** and the second axis **337a** form a single axis. In other embodiments, different spatial relationships may exist between first axis **335a** and second axis **337a**. In some embodiments, the electrodes **315** are arranged in a spatial distribution in which a first electrode **315q** associated with transducer **306q** is intersected by each of the first plane **342a** and the second plane **344a** when the structure **308** is in the deployed configuration. In some embodiments, first electrode **315q** is not intersected by first axis **335a** when structure **308** is in the deployed configuration. In some embodiments, first electrode **315q** is not intersected by second axis **337a** when structure **308** is in the deployed configuration. In some embodiments, the first group **336a** of electrodes **315** includes first electrode **315q**. In some embodiments, the second group of electrodes **338a** does not include first electrode **315q**. In various embodiments, the first axis **335a**, the second axis **337a** or each of the first axis **335a** and the second axis **337a** intersects at least one electrode **315** located on structure **308** (e.g., electrode **315r** associated with transducer **306r** in FIGS. 3C and 3D) that does not include first electrode **315q**. In some embodiments, the first axis **335a**, the second axis **337a** or each of the first axis **335a** and the second axis **337a** does not intersect any electrode **315** located on structure **308**, such as, for example, when no polar electrode (e.g., **315r** in FIGS. 3C and 3D) is provided. In some embodiments, the first axis

335a, the second axis 337a or each of the first axis 335a and the second axis 337a does not intersect any electrode or transducer.

FIG. 3D is a plan view of structure 308 in the deployed configuration of FIG. 3C. The plan view of FIG. 3D has an orientation such that each of first plane 342a and second plane 344a is viewed 'on edge' to their respective planar surfaces. (Note that in embodiments where each of the first plane 342a and the second plane 344a have no thickness, 'on edge' is intended to refer to an 'on edge' perspective assuming that each plane had an edge of minimal thickness.) The plan view of FIG. 3D has an orientation such that each of the first axis 335a and second axis 337a is viewed along the axis in this particular embodiment. Each of first plane 342a and second plane 344a are represented by a respective "heavier" line in FIG. 3D. Each of first axis 335a and second axis 337a are represented by a "●" symbol in FIG. 3D. It is understood that each of the depicted lines or symbols "●" used to represent any corresponding plane, intersection line or axis in this disclosure do not impart any size attributes on the corresponding plane or axis.

In various embodiments, each of the first group 336a and the second group 338a includes two or more of the electrodes 315. In some embodiments, the first group 336a, the second group 338a or each of both the first group 336a and the second group 338a includes three or more of the electrodes 315. In various embodiments, the first group 336a, the second group 338a or each of both the first group 336a and the second group 338a includes a pair of adjacent electrodes 315 located on a respective one of the first elongate member 304a and the second elongate member 304b. In some of these various embodiments, a region of space associated with a physical portion of structure 308 (e.g., an elongate member 304 portion) is located between the respective electrodes 315 of the pair of adjacent electrodes 315 included in the first group 336a, and the region of space is intersected by the first plane 342a when the structure 308 is in the deployed configuration. In some embodiments, the respective electrodes 315 of the first group 336a are spaced along a length of a portion of the first elongate member 304a, the length extending between the respective distal and proximal ends 305, 307 (not called out in FIGS. 3B, 3C, 3D and 3E) of the first elongate member 304a, the entirety of the length of the portion of the first elongate member 304a being intersected by the first plane 342a when structure 308 is in the deployed configuration. In some embodiments, the first plane 342a intersects every electrode 315 located on the first elongate member 304a when structure 308 is in the deployed configuration. In some embodiments, the second plane 344a intersects every electrode 315 that is located on the second elongate member 304b when structure 308 is in the deployed configuration. In some embodiments, some, but not all of the respective electrodes 315 located on the first elongate member 304a, the second elongate member 304b, or each of the first elongate member 304a and the second elongate member 304b are intersected by a corresponding one of the first plane 342a and the second plane 344a when structure 308 is in the deployed configuration.

In some embodiments, the second axis 337a is not colinear with the first axis 335a. In some embodiments, the second axis 337a and the first axis 335a do not form a single axis. In some embodiments, the second axis 337a does not intersect the first axis 335a. FIG. 3D shows another embodiment in which each electrode 315 of second group 338b (not called out in FIGS. 3C and 3E) of electrodes 315 located on second elongate member 304b is intersected by a second plane 344b having no thickness. Second plane 344b is

viewed transversely to its planar surface in FIG. 3D and is represented by a line. Although second plane 344b is depicted parallel to second plane 344a in FIG. 3D, different orientations may be employed in other embodiments. First plane 342a and second plane 344b are non parallel planes that intersect one another along a second axis 337b represented by a symbol "●" in FIG. 3D. For clarity, each of second plane 344b and second axis 337b is not shown in FIG. 3C. In at least one particular embodiment associated with FIG. 3D, each of the first plane 342a and the second plane 344b intersects a first electrode 315s associated with transducer 306s that is not intersected by the second axis 337b. In at least one particular embodiment associated with FIG. 3D, first electrode 315s is not intersected by the first axis 335a. In at least one particular embodiment associated with FIG. 3D, first electrode 315s is not intersected by the second axis 337b. In at least one particular embodiment associated with FIG. 3D, second axis 337b intersects at least one other electrode (e.g., electrode 315t associated with transducer 306t). In at least one particular embodiment associated with FIG. 3D, the intermediate portion 309 of the first elongate member 304a overlaps the intermediate portion 309 of the second elongate member 304b at each of a first location on structure 308 passed through by first axis 335a and a second location on structure 308 passed through by the second axis 337b when structure 308 is in the deployed configuration, the second and first locations being different locations.

In various embodiments, particular spatial distributions of electrodes or transducers similar to the ones employed in FIGS. 3A, 3B, 3C, 3D and 3E may advantageously allow for higher spatial densities of the electrodes or transducers to be employed. For example, as best seen in FIGS. 3C and 3D, various distributions of electrodes 315 having relatively high spatial densities are created throughout a significant portion of structure 308 including various regions proximate first axis 335a. It is noted that portions of various ones of elongate members 304 shown in FIGS. 3C and 3D overlap one another as the portions approach first axis 335a when structure 308 is in the deployed configuration. In various embodiments, overlapping elongate members 304 may be employed at least in part to provide to distributions of the electrodes 315 having higher spatial densities. In FIGS. 3C and 3D, a portion of a first elongate member 304 (e.g., elongate member 304a) is shown overlapping a portion of at least a second elongate member 304 (e.g., elongate member 304b) when structure 308 is in the deployed configuration. FIG. 3E includes an enlarged view of a portion of the structure 308 depicted in FIG. 3D, the portion of structure 308 including portions of at least elongate members 304a and 304b. For clarity of illustration, planes 342a, 344a, 344b and axis 337b are not shown in FIG. 3E. In at least one particular embodiment associated with FIG. 3E, a portion 346a (i.e., only called out in FIG. 3E) of the front surface of 318a of first elongate member 304a overlaps a portion 347a (i.e., only called out in FIG. 3E, partially bounded by a ghosted line 345a for clarity) of the front surface 318a of second elongate member 304b as viewed normally to the portion 346a of the front surface 318a of first elongate member 304a when structure 308 is in the deployed configuration. In this particular embodiment, the spatial density of the distribution of transducers 306/electrodes 315 is such that at least a first electrode (e.g., electrode 315q associated with transducer 306q) is located at least on the portion 346a of the front surface 318a of first elongate member 304a. In some embodiments, the portion of 347a of the front surface 318a of second elongate member 304b faces the back

surface **318b** (not called out in FIG. 3E) of first elongate member **304a** when structure **308** is in the deployed configuration. In some embodiments, the portion of **347a** of the front surface **318a** of second elongate member **304b** faces the back surface **318b** of first elongate member **304a** when structure **308** is in the delivery configuration (e.g., when the elongate members **304** are arranged front surface-toward-back surface in a stacked array (e.g., when the structure **308** is in a delivery configuration similar to that depicted in FIG. 3A). In some example embodiments, the portion **347a** of the front surface **318a** of second elongate member **304b** contacts the back surface **318b** of first elongate member **304a** when structure **308** is in the deployed configuration. In a similar manner, a portion **346b** (i.e., only called out in FIG. 3E) of the front surface of **318a** of elongate member **304b** overlaps a portion **347b** (i.e., only called out in FIG. 3E, partially bounded by a ghosted line **345b** for clarity) of the front surface **318a** of elongate member **304c** as viewed normally to the portion **346b** of the front surface **318a** of elongate member **304b** when structure **308** is in the deployed configuration. In this case, a first electrode (e.g., electrode **316u** associated with transducer **306u**) is located at least on the portion **346b** of the front surface **318a** of elongate member **304b**.

Other spatial characteristics are associated with the distribution of transducers **306**/electrodes **315** associated with various embodiments associated with FIGS. 3A, 3B, 3C, 3D and 3E. For example, as best seen in FIG. 3E, a first side edge **327a** of the first elongate member **304a** crosses a first side edge **327a** of the pair of side edges of the second elongate member **304b** at a first location **351a** and crosses a second side edge **327b** of the pair of side edges of the second elongate member **304b** at a second location **352a** when structure **308** is in the deployed configuration. In various embodiments associated with FIG. 3E, various electrodes **315** are located at least on a portion **348a** of the second elongate member **304b**, the portion **348a** of the second elongate member **304b** located between a first transverse line **349a** and a second transverse line **349b** (e.g., each depicted by a ghosted line in FIG. 3E) when the structure **308** is in the deployed configuration. In various embodiments associated with FIG. 3E, the first transverse line **349a** extends across a first width **353a** of the second elongate member **304b** at the first location **351a**, and the second transverse line **349b** extends across a second width **353b** of the second elongate member **304b** at the second location **352a**. In at least one particular embodiment associated with FIG. 3E, the first width **353a** and the second width **353b** are the widths of the front surfaces **318a** of the second elongate member **304b**. In at least one particular embodiment associated with FIG. 3E, a magnitude of first width **353a** is substantially the same as a magnitude of the second width **353b**. In some embodiments, the magnitude of the first width **353a** is different than the magnitude of the second width **353b**. In some embodiments, the first transverse line **349a** is perpendicular to one or both of the side edges **327a**, **327b** of the second elongate member **304b**. Similarly, in some embodiments, the second transverse line **349b** is perpendicular to one or both of the side edges **327a**, **327b** of the second elongate member **304b**. In some embodiments, the magnitude of the first width **353a** is a minimum with respect to all other respective magnitudes of possible widths between side edges **327a**, **327b** of the second elongate member **304b** originating at location **351a**. Similarly, in some embodiments, the magnitude of the second width **353b** is a minimum with respect to all other respective magnitudes

of possible widths between side edges **327a**, **327b** of the second elongate member **304b** originating at location **352a**.

In some example embodiments, one or more of the electrodes **315** are wholly located on the portion **348a** of the second elongate member **304b** when the structure **308** is in the deployed configuration. For example, electrode **315u** is wholly located on the portion **348a** (which is rectangular in some embodiments such as FIG. 3E) of the second elongate member **304b** when the structure **308** is in the deployed configuration. In some example embodiments, at least a portion of an electrode **315** of the plurality of electrodes **315** is located on the portion **348a** of the second elongate member **304b** when structure **308** is in the deployed configuration. As shown, for example, in FIG. 3E, electrode **315v** is located at least on portion **348a** in the deployed configuration. In various other embodiments, two or more of the electrodes **315** may be located on the portion **348a** of the second elongate member **304b**.

It may be noted that distances between adjacent ones of the elongate members **304** shown in FIGS. 3C, 3D and 3E vary as elongate members **304** extend towards first axis **335a** when structure **308** is in the deployed configuration. In some cases, the varying distances between adjacent elongate members **304** in the deployed configuration may give rise to shape, size or dimensional constraints for the electrodes **315** located on the elongate members **304**. In some cases, the overlapping portions of various ones of the elongate members **304** in the deployed configuration may give rise to shape, size or dimensional constraints for the electrodes **315** located on the portions of the various ones of the elongate members **304**. For example, it may be desirable to reduce a surface area of an electrode adjacent an overlap region on an overlapped elongate member to accommodate the reduced-exposed-surface area of the overlapped elongate member in the region adjacent the overlap region (e.g., electrode **315u** in FIG. 3E).

In various embodiments, the respective shape of various electrically conductive surfaces (e.g., energy transmission surfaces **319**) of various ones of the electrodes **315** vary among the electrodes **315**. In various embodiments, the respective shape of various electrically conductive surfaces (e.g., energy transmission surfaces **319**) of various ones of the electrodes **315** vary among the electrodes **315** in accordance with their proximity to first axis **335a**. In various embodiments, one or more dimensions or sizes of various electrically conductive surfaces (e.g., energy transmission surfaces **319**) of various ones of the electrodes **315** vary among the electrodes **315**. In various embodiments, one or more dimensional sizes of various electrically conductive surfaces (e.g., energy transmission surfaces **319**) of various ones of the electrodes **315** vary in accordance with their proximity to first axis **335a**. The shape or size variances associated with various ones of the electrodes **315** may be motivated for various reasons. For example, in various embodiments, the shapes or sizes of various ones of the electrodes **315** may be controlled in response to various ones of the aforementioned size or dimensional constraints.

Referring to FIG. 3E, it is noted that each of various ones of the electrodes **315** (e.g., electrodes **315u** and **315v**) located at least on second elongate member **304b** have various electrode edges (e.g., **315-1** in FIG. 3C or **415-1** in FIG. 4) that form a periphery of an electrically conductive surface associated with each of the various electrodes **315** (e.g., an energy transmission surface **319**). In at least one particular embodiment associated with FIG. 3E, a first electrode edge **333a** associated with electrode **315u** is arranged to follow a portion of the first side edge **327a** of the

first elongate member **304a** between the first location **351a** and the second location **352a** when the structure **308** is an expanded or deployed configuration. In some embodiments, the first electrode edge **333a** of electrode **315u** is arranged to be parallel to the portion of the first side edge **327a** of the first elongate member **304** between the first location **351** and the second location **352** when the structure **308** is in an expanded or deployed configuration. In this particular embodiment, a second electrode edge **333b** forming part of the periphery of electrically conductive surface associated with electrode **315u** is positioned opposite across the electrically conductive surface from the first electrode edge **333a**. In this particular embodiment, the second electrode edge **333b** is arranged to follow a portion of one of the side edges **327** of the second elongate member **304b** (e.g., side edge **327a** of second elongate member **304b**). In this particular embodiment, the second electrode edge **333b** is substantially parallel to the side edge **327a** of second elongate member **304b**.

FIGS. 3F and 3G respectively show perspective and plan views of a plurality of transducers and electrodes located on a structure **313** (e.g., in a deployed configuration) according to various embodiments. In various embodiments, structure **313** is selectively moveable from a delivery configuration to a deployed configuration in a manner similar to structure **308**. It is noted that structure **313** is depicted in FIGS. 3F and 3G in a similar fashion to depictions of structure **308** in FIGS. 3C and 3D. In some embodiments, distributions of transducers or electrodes similar to those employed by structure **313** are employed by the structure **308** of FIGS. 3A, 3B, 3C, 3D and 3E. For the convenience of discussion, various elements associated with structure **313** will be identified by the respective part numbers of the corresponding elements associated with structure **308**. For example, in reference to FIGS. 3F and 3G and other associated Figures, transducers are referred to as transducers **306**, electrodes are referred to as electrodes **315**, energy transmission surfaces are referred to as energy transmission surfaces **319**, elongate members are referred to as elongate members **304**, et cetera. It is noted that these elements disclosed in FIGS. 3F and 3G and other associated Figures are not limited to the embodiments of corresponding elements disclosed in FIGS. 3A, 3B, 3C, 3D and 3E. In some embodiments, structure **313** may assume a delivery configuration similar to that shown for structure **308** in FIG. 3A.

It may be noted that although the distributions of transducers **306**/electrodes **315** associated with structure **313** have differences from the distribution of transducers **306**/electrodes **315** associated with structure **308**, there are also similarities. The respective intermediate portions **309** of various ones of the elongate members **304** (five called out in each of FIGS. 3F and 3G, four of the five called out as **304d**, **304e**, **304f** and **304g**) are angularly spaced with respect to one another about a first axis **335b** when structure **313** is in the deployed configuration in a manner similar to that previously described with respect to structure **308**. Various ones of the elongate members **304** cross one another at a location on the structure **313** passed through by first axis **335b** when the structure **313** is in the deployed configuration. In at least one particular embodiment associated with FIGS. 3F, 3G, the intermediate portion **309** of a first elongate member (e.g., elongate member **304d**) overlaps the intermediate portion **309** of a second elongate member (e.g., elongate member **304e**) at a location on structure **313** passed through by first axis **335b** when structure **313** is in the deployed configuration. In at least one particular embodiment associated with FIGS. 3F, 3G, the intermediate portion

**309** of first elongate member **304d** is adjacent the intermediate portion **309** of the second elongate member **304e** when structure **313** is in the deployed configuration. The transducers **306** (nine called out in each of FIGS. 3F and 3G, eight of the nine called as transducers **306w**, **306x**, **306y**, **306z**, **306aa**, **306bb**, **306cc**, and **306dd**) and electrodes **315** (nine called out in each of FIGS. 3F and 3G, eight of the nine called out as electrodes **315w**, **315x**, **315y**, **315z**, **315aa**, **315bb**, **315cc** and **315dd**) are radially spaced about first axis **335b** when structure **313** is in the deployed configuration in a manner similar to the embodiments associated with structure **308**. The plurality of electrodes **315** located on structure **313** includes a first group **336b** (not called out in FIGS. 3H, 3I) of the electrodes **315** located on first elongate member **304d** and a second group **338c** (not called out in FIGS. 3H, 3I) of the electrodes **315** located on second elongate member **304e**. It is understood that although electrodes are herein described, other forms of transducers or transducer elements may be employed in other embodiments. The electrodes **315** of the first group **336b** are arranged such that each electrode **315** of the first group **336b** is intersected by a first plane **342b** having no thickness. The electrodes **315** of the second group **338c** are arranged such that each electrode **315** of the second group **338c** is intersected by a second plane **344c** having no thickness. For clarity, the intersection of each electrode **315** of the first group **336b** by first plane **342b** is represented in FIG. 3F by intersection line **345c**. For clarity, the intersection of each electrode **315** of the second group **338c** by second plane **344c** is represented in FIG. 3F by intersection line **345d**. First plane **342b** and second plane **344c** are depicted as having boundaries for clarity of illustration in FIG. 3F.

Each of the first plane **342b** and the second plane **344c** are non-parallel planes that intersect each other along a second axis **337c** (represented by a symbol "●" in FIG. 3G). In some embodiments, second axis **337c** is parallel to first axis **335b**. In some embodiments, first axis **335b** and second axis **337c** are collinear. In some embodiments, the first axis **335b** and the second axis **337c** form a single axis. In some embodiments, the electrodes **315** are arranged in a spatial distribution in which a first electrode **315** (e.g., electrode **315w** associated with transducer **306w**) is intersected by each of the first plane **342b** and the second plane **344c** when the structure **313** is in the deployed configuration. In at least one particular embodiment, first electrode **315w** is not intersected by first axis **335b** when structure **313** is in the deployed configuration. In at least one particular embodiment, first electrode **315w** is not intersected by second axis **337c** when structure **313** is in the deployed configuration. In at least one particular embodiment, the first group **336b** of electrodes **315** includes first electrode **315w**. In at least one particular embodiment, the second group of electrodes **338c** does not include first electrode **315w**. In various embodiments, the first axis **335a**, the second axis **337c** or each of the first axis **335** and the second axis **337c** intersects at least one other electrode **315** located on structure **313** (e.g., electrode **315x** associated with transducer **306x** in FIGS. 3F, 3G and 3I). In some embodiments, the first axis **335b**, the second axis **337c** or each of the first axis **335b** and the second axis **337c** do not intersect any electrode **315** located on structure **313**.

In some embodiments, the second axis **337c** is not collinear with the first axis **335b**. In some embodiments, the second axis **337c** and the first axis **335b** do not form a single axis. In some embodiments, the second axis **337c** does not intersect the first axis **335b**. FIG. 3G shows another embodiment in which each electrode **315** of second group **338d** (not

called out in FIGS. 3F, 3H and 3I) of electrodes 315 located on a second elongate member 304f is intersected by a second plane 344d having no thickness when structure 313 is in a deployed configuration. Second plane 344d is viewed transversely to its planar surface in FIG. 3G and is represented by a line. For clarity, second plane 344d is not shown in FIG. 3F. First plane 342b and second plane 344d are non parallel planes that intersect one another along a second axis 337d represented by a symbol "●" in FIG. 3G. In at least one particular embodiment, each of the first plane 342b and the second plane 344d intersects a first electrode 315y associated with transducer 306y when structure 313 is in a deployed configuration. In at least one particular embodiment, first electrode 315y is not intersected by the first axis 335b when structure 313 is in a deployed configuration. In at least one particular embodiment, first electrode 315y is not intersected by the second axis 337d when structure 313 is in a deployed configuration. In at least one particular embodiment, second axis 337d intersects at least one other electrode (e.g., electrode 315z associated with transducer 306z) when structure 313 is in a deployed configuration.

Embodiments associated with FIGS. 3F and 3G have spatial distributions of the transducers 306/electrodes 315 that have relatively high spatial densities in various regions of structure 313 including a plurality of regions proximate first axis 335b. In various embodiments, a spatial distribution of the transducers 306/electrodes 315 in various regions proximate first axis 335b have higher spatial densities than similar distributions associated with various embodiments of FIGS. 3A, 3B, 3C, 3D and 3E. Embodiments associated with FIGS. 3F and 3G may provide for electrodes 315 having electrically conductive surfaces (e.g., energy transmission surfaces 319, three called out in each of FIGS. 3F and 3G, two of the three called out as 319c and 319d) of greater size or dimension than some of the electrodes 315 associated with various embodiments of FIGS. 3A, 3B, 3C, 3D and 3E. In particular, larger electrodes 315 may be provided in regions proximate first axis 335b in at least some of the embodiments associated with FIGS. 3F and 3G. The use of larger electrodes (e.g., larger electrically conductive surfaces such as energy transmission surfaces 319c and 319d) may be motivated for various reasons. For example, in some tissue ablation applications, tissue ablation depths may be dependent on the size of the electrodes 315 employed for the ablation, with a use of larger electrodes 315 typically reaching a particular ablation depth in a shorter activation time than a use of relatively smaller electrodes 315. In some tissue ablation applications, deeper tissue ablation depths may be associated with larger electrodes.

FIG. 3H is shows perspective views of each of first elongate member 304d and second elongate member 304e in a "flattened" configuration in which the curved form of these elongate members 304 in FIGS. 3F and 3G is flattened out. It is noted that in embodiments where the elongate members 304 in FIGS. 3F and 3G include a twisted portion similar to the twisted portions of various ones of the elongate members 304 associated with FIGS. 3A, 3B, 3C, 3D and 3E, the twisted portions are shown untwisted in the flattened configuration of FIG. 3H. The flattened configuration is presented for clarity of illustration and it is understood that in the deployed configuration, FIGS. 3F and 3G are better representative of the forms of various ones of the elongate members at least in the deployed configuration. In a manner similar to the elongate members 304 of structure 308, the intermediate portion 309 of each of the elongate members 304d, 304e includes a front surface 318a and back surface 318b opposite across a thickness 318c of the elongate

member. In some embodiments, at least some of the transducers 306/electrodes 315 are located on the front surfaces 318a. Each intermediate portion 309 includes a respective pair of side edges 327a, 327b. In various embodiments, the side edges 327a, 327b of each intermediate portion 309 are respective side edges of the front surface 318a, the back surface 318b, or both the front surface 318a and the back surface 318b of the intermediate portion 309. Each of the pair of side edges 327a, 327b extends between the proximal end 307 and the distal end 305 of the elongate member 304.

In some embodiments associated with FIGS. 3F and 3G, various ones of elongate members overlap one another when structure 313 is in the deployed configuration. In various embodiments, overlapping elongate members 304 may be employed at least in part to provide to distributions of the electrodes 315 having higher spatial densities. FIG. 3I includes an enlarged view of a portion of the structure 313 depicted in FIG. 3G, the portion of structure 313 including portions of at least elongate members 304d and 304e. For clarity of illustration, planes 342b, 344c, 344d and axis 337d are not shown in FIG. 3I.

In at least one particular embodiment, various portions of the front surface 318a of the first elongate member 304d overlap various portions of the front surface 318a of each of several ones of the plurality of elongate members 304 when structure 313 is in the deployed configuration. In at least one particular embodiment, various portions of the front surface 318a of the first elongate member 304d overlap various portions of the front surface 318a of every other one of the plurality of elongate members 304 when structure 313 is in the deployed configuration. In at least one particular embodiment associated with FIG. 3I, a portion 346c (i.e., only called out in FIG. 3I) of the front surface of 318a of a first elongate member 304 (e.g., elongate member 304d) overlaps a portion 347c (i.e., only called out in FIG. 3I, partially bounded by a ghosted line 345c) of the front surface 318a of at least a second elongate member (e.g., elongate member 304e) as viewed normally to the portion 346a of the front surface 318a of first elongate member 304a when structure 313 is in the deployed configuration. In at least one particular embodiment, the spatial density of the distribution of transducers 306/electrodes 315 is such that at least a first electrode (e.g., first electrode 315w associated with transducer 306w) is located at least on the portion 346c of the front surface 318a of first elongate member 304d. In at least one particular embodiment, the portion of 347c of the front surface 318a of second elongate member 304e faces the back surface 318b (not called out in FIG. 3I) of first elongate member 304d when structure 313 is in the deployed configuration. In some embodiments, the portion of 347c of the front surface 318a of second elongate member 304e faces the back surface 318b of first elongate member 304d when structure 313 is in the delivery configuration (e.g., when the elongate members 304 are arranged front surface-toward-back surface in a stacked array when the structure 313 is in a delivery configuration similar to that depicted in FIG. 3A). In some example embodiments, the portion of 347c of the front surface 318a of second elongate member 304e contacts the back surface 318b of first elongate member 304d when structure 313 is in the deployed configuration.

In FIGS. 3F, 3G and 3I, the first elongate member 304d is positioned such that first edge 327a of the first elongate member 304d crosses at least a second edge of the second elongate member 304e (e.g., second edge 327b of second elongate member 304e) when structure 313 is in the deployed configuration. In some of the embodiments associated with FIGS. 3F, 3G, 3H and 3I a portion of the first

edge **327a** of the first elongate member **304d** forms a recessed portion **328a** of first elongate member **304d** that exposes at least a portion of a second transducer **306aa** (e.g., second electrode **315aa** in at least one particular embodiment) located on second elongate member **304e**. All recessed portions such as recessed portion **328a** described herein are collectively referred to as recessed portions **328**. In at least some of the embodiments associated with FIGS. **3F**, **3G**, **3H** and **3I**, the exposed portion of second transducer **306aa** (e.g., electrode **315aa**) is located at least on portion of a surface (e.g., front surface **318a**) of the second elongate member **304e** as viewed normally to the portion of the surface of the second elongate member **304e** when structure **313** is in the deployed configuration. In at least some of the embodiments associated with FIGS. **3F**, **3G**, **3H** and **3I**, recessed portion **328a** of first elongate member **304d** exposes at least a portion of second electrode **315aa** as viewed normally to a surface of the exposed portion of second electrode **315aa**. In at least some of the example embodiments associated with FIGS. **3F**, **3G**, **3H** and **3I**, the exposed portion of second transducer **306aa** (e.g., electrode **315aa**) is located on the second elongate member **304e** as viewed towards the second transducer **306aa** along a direction parallel to a direction that the first axis **335b** extends along when structure **313** is in the deployed configuration. In some embodiments, the second group **338c** includes second transducer **306aa** (e.g., electrode **315aa**). As best shown in FIGS. **3G** and **3I**, in some embodiments, the second transducer **306aa** (e.g., electrode **315aa**) is adjacent first transducer **306w** (e.g., electrode **315w**) when structure **313** is in the deployed configuration. In various embodiments associated with FIGS. **3F**, **3G**, **3H** and **3I**, at least some of the plurality of transducers **306**/electrodes **315** are arranged in a plurality of concentric ringed arrangements **329** (four called out in FIG. **3G** (one of which is shown by a ghosted line), two of the four called out as **329a**, **329b**) about the first axis **335b** when structure **313** is in the deployed configuration, a first one of the ringed arrangements **329** (e.g., ringed arrangement **329a**) having a fewer number of the transducers **306** (e.g., electrodes **315**) than a second one of the ringed arrangements (e.g., ringed arrangement **329b**). In some of these various example embodiments, the first ringed arrangement includes first transducer **306w** (e.g., electrode **315w**). In some of these various embodiments, the first ringed arrangement **329a** does not include any of the transducers **306** (e.g., electrodes **315**) located on the second elongate member **304e**. In some of these example embodiments, the second ringed arrangement **329b** includes the second transducer **306aa**. In some of these various embodiments, the first ringed arrangement **329a** is adjacent the second ringed arrangement **329b**.

In various embodiments, first elongate member **304d** includes a second recessed portion **328b** (called out in FIGS. **3F**, **3G** and **3H**) arranged to expose a portion of at least one transducer (e.g., electrode **315bb** associated with transducer **306bb**) located on second elongate member **304e** when structure **313** is in the deployed configuration. In various embodiments, second elongate member **304e** includes several recessed portions (e.g., recessed portions **328c** and **328d** called out in FIGS. **3H**, **3I**). In at least one particular embodiment, each of the recessed portions **328c** and **328d** has different dimensions or sizes than each of recessed portions **328a** and **328b**. Differences in the dimensions or sizes of various ones of the recessed portions **328** (e.g., any of recessed portions **328a**, **328b**, **328c**, **328d** and other described recessed portions) may be motivated by various reasons including the location of their corresponding elon-

gate member **304** in structure **313** or a spatial relationship between various ones of the transducers **306**/electrodes **315** in the deployed configuration. In some embodiments, the differences in the sizes or dimensions of various ones of the recessed portions **328** may be employed to create distribution of transducers **306**/electrodes **315** having higher spatial densities. In various embodiments, each recessed portion **328c**, **328d** is arranged to expose a portion of at least one transducer **306** (e.g., electrode **315cc** associated with transducer **306cc** and electrode **315dd** associated with transducer **306dd**) located on elongate member **304g** when structure **313** is in the deployed configuration. This is best shown in FIG. **3J** which shows a plan view of structure **313** in the deployed configuration similar to that shown in FIG. **3G** with the exception that elongate member **304d** is not shown. It is understood that elongate member **304d** is not shown in FIG. **3J** only to better show elongate member **304e** and its associated recessed portions **328c** and **328d**. For clarity of illustration, planes **342b**, **344c**, **344d** and axes **335b**, **337c**, **337d** are not shown in FIG. **3J**.

In various embodiments associated with FIG. **3J**, a first side edge **327a** of a first elongate member (e.g., elongate member **304e**) crosses a first side edge **327a** of the pair of side edges of a second elongate member (e.g., elongate member **304g**) at a first location **351b** and crosses a second side edge **327b** of the pair of side edges of the second elongate member **304g** at a second location **352b** when structure **313** is in the deployed configuration. In various embodiments associated with FIG. **3J**, various electrodes **315** are located at least on a portion **348b** of the second elongate member **304g**, the portion **348b** of the second elongate member **304g** located between a first transverse line **349c** and a second transverse line **349d** (e.g., each depicted by a ghosted line in FIG. **3J**) when the structure **313** is in the deployed configuration. In various embodiments associated with FIG. **3J**, the first transverse line **349c** extends across a first width **353c** of the second elongate member **304g** at the first location **351b** and the second transverse line **349d** extends across a second width **353d** of the second elongate member **304g** at the second location **352b**. In at least one particular embodiment associated with FIG. **3J**, the first width **353c** and the second width **353d** are the widths of the front surfaces **318a** of the second elongate member **304g**. In at least one particular embodiment associated with FIG. **3J**, a magnitude of first width **353c** is substantially the same as a magnitude of the second width **353d**. In some embodiments, a magnitude of the first width **353c** is different than a magnitude of the second width **353d**. In at least one particular embodiment associated with FIG. **3J**, each of electrodes **315cc** associated with transducer **306cc** and electrode **315dd** associated with transducer **306dd** is wholly located on the portion **348b** of the second elongate member **304g** when the structure **313** is in the deployed configuration. In at least one particular embodiment associated with FIG. **3J**, electrode **315ee** associated with transducer **306ee** is located at least on portion **348b** in the deployed configuration. Similar arrangements exist between other sets of the elongate members **304** of structure **313** in the deployed configuration. For example, referring to FIG. **3I**, a first elongate member (e.g., elongate member **304d**) is positioned such that its first edge **327a** crosses a first side edge **327a** of a second elongate member (elongate member **304e**) at a first location **351c** and crosses a second side edge **327b** of the second elongate member **304e** at a second location **352c** when the structure **313** is in the deployed configuration. Electrode **306aa** associated with transducer **306aa** is wholly located on a portion **348c** of the second

elongate member **304e**, the portion **348c** located between a first transverse line **349e** and a second transverse line **349f** when the structure **313** is in the deployed configuration. The first transverse line **349e** extends across a first width **353e** of the second elongate member **304e** at the first location **351c**, and the second transverse line **349f** extends across a second width **353f** of the second elongate member **304e** at the second location **352c**. In this particular embodiment, the first width **353e** is smaller than the second width **353f**.

In a manner similar to embodiments associated with FIGS. **3A**, **3B**, **3C**, **3D** and **3E**, electrically conductive surfaces (e.g., energy transmission surfaces **319**) of various ones of the electrodes **315** employed in various embodiments associated with FIGS. **3F**, **3G**, **3H**, **3I**, and **3J** may have different sizes or shapes. For example, referring to FIG. **3J**, it is noted that each of various one of the electrodes **315** (e.g., electrodes **315cc**, **315dd** and **315ee**) located on at least one elongate member **304g** have different shapes and sizes. In at least one particular embodiment associated with FIG. **3J**, a periphery of an electrically conductive surface (e.g., an energy transmission surface **319**) of various ones of the electrodes **315** is defined by various electrode edges. For example, electrode **315dd** includes a first electrode edge **333c** and a second electrode edge **333d** opposite across an electrically conductive surface of electrode **315dd** from the first electrode edge **333c**. In at least one particular embodiment, the first electrode edge **333c** associated with electrode **315dd** is arranged to follow a portion of the first side edge **327a** of the overlapping elongate member **304e** between the first location **351b** and the second location **352b** when the structure **313** is in an expanded or deployed configuration. In at least one particular embodiment, the first electrode edge **333c** of electrode **315dd** is arranged to be parallel to the portion of the first side edge **327a** of the overlapping elongate member **304e** between the first location **351b** and the second location **352b** when the structure **313** is in an expanded or deployed configuration. In at least one particular embodiment, the first electrode edge **333c** of electrode **315dd** is arranged to follow a portion of the first side edge **327a** that defines or forms part of, the recessed portion **328c** of overlapping elongate member **304e** in the expanded or deployed configuration. In at least one particular embodiment, the second electrode edge **333d** associated with electrode **315dd** is arranged to follow a portion of one of the side edges **327** of elongate member **304g** (e.g., side edge **327a** of second elongate member **304g**). In at least one particular embodiment, the second electrode edge **333d** associated with electrode **315dd** is arranged to follow a portion of one of the side edges **327** of elongate member **304g** (e.g., side edge **327a** of second elongate member **304g**) that defines, or forms part of, a recessed portion **328j** of the elongate member **304g**. In at least one particular embodiment, a first part of a first electrode edge **333e** associated with electrode **315ee** located on elongate member **304g** is arranged to follow a portion of the first side edge **327a** that defines, or forms part of, the recessed portion **328c** of overlapping elongate member **304e** when structure **313** is in the deployed configuration, and a second part of the first electrode edge **333e** of electrode **315ee** is arranged to follow a portion of the first side edge **327a** that does not define or form part of the recessed portion **328c** of overlapping elongate member **304e** when structure **313** is in an expanded or deployed configuration. In at least one particular embodiment, a first part of a second electrode edge **333f** associated with electrode **315ee** is arranged to follow a portion of the first side edge **327a** that defines, or forms part of, the recessed portion **328j** of the elongate member **304g**, and a second part of the

second electrode edge **333f** is arranged to follow a portion of the first side edge **327a** of elongate member **304j** that does not define, or form part of, the recessed portion **328j**.

In at least one particular embodiment associated with FIGS. **3F**, **3G**, **3H**, and **3I**, the edge **327a** of the first elongate member **304d** is interrupted by a notch **330a**. Similarly, in some embodiments, the edge **327a** of the first elongate member **304d** is interrupted by recessed portion **328a** of the first elongate member **304d**. In some embodiments, the recessed portion **328a** forms at least a portion of the notch **330a**. In this particular illustrated embodiment, notch **330a** is located in the intermediate portion **309** of the first elongate member **304d** and extends towards the second edge **327b**. In a similar fashion, the recessed portions **328b**, **328c** and **328d** may form a portion of a respective one of notches **330b**, **330c** and **330d** (called out in FIG. **3H**) in various embodiments. In various embodiments associated with FIGS. **3F**, **3G**, **3H**, **3I** and **3J**, various ones of the recessed portions **328** may be advantageously employed to create, at least in part, a spatial distribution of the transducers **315** having a relatively high spatial density. In various embodiments associated with FIGS. **3F**, **3G**, **3H**, **3I** and **3J**, various ones of recessed portions **328** may be advantageously employed to address, at least in part, transducer size or shape constraints associated with structure **313** (e.g., overlapping regions of elongate members **304** or varying distances between various elongate members **304**). In various embodiments associated with FIGS. **3F**, **3G**, **3H**, **3I** and **3J**, various ones of recessed portions **328** may allow, at least in part, for the use of electrodes **315** having relatively large electrically conductive surfaces (e.g., energy transmission surfaces **319**). Other benefits may accompany the use of recessed portions such as recessed portions **328**. For example, in some embodiments, recessed portions similar to various ones of recess portions **328** may be employed to increase fluid flow (e.g., blood flow) in a particular region of structure **313** (e.g., a region where elongate members **304** overlap one another) that may hinder or otherwise obstruct a flow of fluid (e.g., blood flow).

In other embodiments, various ones of the recessed portions **328** may take a form other than a notch (e.g., notch **330a**). For example, FIG. **3K** includes a perspective view of two elongate members **304h** and **304i** in a flattened configuration similar to that shown by elongate members **304d** and **304e** in FIG. **3H**. Elongate members **304h** and **304i** are similar to elongate members **304d** and **304e** in various embodiments, form part of structure of a transducer-based device system (not shown) similar to structures **308**, **313**. In some of these various embodiments, the structure may be configurable between a delivery configuration and a deployed configuration similar to that previously described in this detailed description. In some of these various embodiments, elongate member **304h** overlaps elongate member **304i** when the structure is the deployed configuration in a manner similar to elongate members **304d** and **304e**. For convenience of discussion, various elements of each of elongate members **304h** and **304i** are identified by the same part numbers employed to identify similar elements in other previously described elongate members. In some embodiments, each of elongate members **304h** and **304i** includes an intermediate portion **309** that includes a front surface **318a** and back surface **318b** opposite across a thickness **318c** of the elongate member. In some embodiments, at least some of the transducers **306**/electrodes **315** are located on the front surfaces **318a**. Each intermediate portion **309** includes a respective pair of side edges **327a**, **327b** extending between proximal and distal ends **307**, **305** of the elongate member

304. In a manner similar to that shown in FIGS. 3F, 3G, and 3I the first elongate member 304h may be positioned such that first edge 327a of the first elongate member 304h crosses a second edge 327b of the second elongate member 304i when the associated structure is in the deployed configuration. In a manner similar to elongate members 304d, 304e, each of the elongate members 304h, 304i includes a set of recessed portions 328 (e.g., associated ones of recessed portions 328e, 328f, 328g, 328h). In some embodiments, each of the elongate members 304h, 304i includes a jogged portion (e.g., a respective one of jogged portions 331a, 331b), each jogged portion undergoing at least one change in direction as the jogged portion extends between the proximal and distal ends 307, 305 of the respective elongate member. In various embodiments, various ones of the recessed portions 328e, 328f, 328g and 328h may form a part of one of the jogged portions 331a, 331b. In various embodiments, various ones of the recessed portions 328e, 328f, 328g and 328h may be located on respective ones of the elongate members 304h and 304i to expose a portion of at least one transducer 306/electrode 315 located on another elongate member 304 (e.g., when an associated structure that includes the elongate members 304 is in a deployed configuration). In other example embodiments, a surface of a particular one of the elongate members may be interrupted by a channel (e.g., trough, groove, aperture), the channel located to expose a portion of at least one transducer 306/electrode 315 located on another elongate member 304 especially when an associated structure that includes the elongate members 304 is in a deployed configuration.

While some of the embodiments disclosed above are described with examples of cardiac mapping, the same or similar embodiments may be used for mapping other bodily organs, for example gastric mapping, bladder mapping, arterial mapping and mapping of any lumen or cavity into which the devices of the present invention may be introduced.

While some of the embodiments disclosed above are described with examples of cardiac ablation, the same or similar embodiments may be used for ablating other bodily organs or any lumen or cavity into which the devices of the present invention may be introduced.

Subsets or combinations of various embodiments described above can provide further embodiments.

These and other changes can be made to the invention in light of the above-detailed description. In general, in the following claims, the terms used should not be construed to limit the invention to the specific embodiments disclosed in the specification and the claims, but should be construed to include other transducer-based device systems including all medical treatment device systems and medical diagnostic device systems in accordance with the claims. Accordingly, the invention is not limited by the disclosure, but instead its scope is to be determined entirely by the following claims.

What is claimed is:

1. A medical device system comprising:

a structure comprising a plurality of elongate members, each of the elongate members comprising a proximal end, a distal end, and an intermediate portion between the proximal and distal ends; and

a plurality of electrodes located on the structure, the plurality of electrodes positionable in a bodily cavity, a first group of the electrodes located on a first elongate member of the plurality of elongate members and a second group of the electrodes located on a second elongate member of the plurality of elongate members, wherein the structure is selectively moveable between:

a delivery configuration in which the structure is sized to be percutaneously delivered to the bodily cavity, and  
 a deployed configuration in which the structure is expanded to have a size too large to be percutaneously delivered to the bodily cavity, wherein the intermediate portions of the elongate members are angularly arranged with respect to one another about a first axis when the structure is in the deployed configuration, each electrode of the first group of the electrodes intersected by a first plane having no thickness and each electrode of the second group of the electrodes intersected by a second plane having no thickness when the structure is in the deployed configuration, wherein the first and the second planes are non-parallel planes that intersect each other along a second axis, and wherein at least a first electrode of the plurality of electrodes is intersected by each of the first plane and the second plane when the structure is in the deployed configuration, the first electrode not intersected by each of the first axis and the second axis when the structure is in the deployed configuration.

2. The medical device system of claim 1 wherein the second axis is parallel to the first axis.

3. The medical device system of claim 2 wherein the first axis and the second axis are collinear.

4. The medical device system of claim 3 wherein the first axis intersects at least one electrode of the plurality of electrodes that does not include the first electrode when the structure is in the deployed configuration.

5. The medical device system of claim 2 wherein the second axis intersects at least one electrode of the plurality of electrodes that does not include the first electrode when the structure is in the deployed configuration.

6. The medical device system of claim 1 wherein each of the plurality of elongate members comprises a curved portion having a curvature configured to cause the curved portion to extend along at least a portion of a respective curved path, the curvature configured to cause the curved path to intersect the first axis at each of a respective at least two spaced apart locations along the first axis when the structure is in the deployed configuration.

7. The medical device system of claim 1 wherein at least some of the plurality of electrodes are radially spaced about the first axis when the structure is in the deployed configuration.

8. The medical device system of claim 1 wherein at least some of the plurality of electrodes are circumferentially arranged about the first axis when the structure is in the deployed configuration.

9. The medical device system of claim 1 wherein the intermediate portion of the first elongate member overlaps the intermediate portion of the second elongate member at a location on the structure passed through by the first axis when the structure is in the deployed configuration.

10. The medical device system of claim 1 wherein the intermediate portion of the first elongate member overlaps the intermediate portion of the second elongate member at each of a first location on the structure passed through by the first axis and a second location on the structure passed through by the second axis when the structure is in the deployed configuration.

11. The medical device system of claim 1 wherein at least some of the plurality of electrodes are arranged in a plurality of concentric ringed arrangements when the structure is in the deployed configuration, a first one of the plurality of concentric ringed arrangements having a fewer number of the electrodes than a second one of the plurality of concen-

tric ringed arrangements, the first one of the plurality of concentric ringed arrangements comprising the first electrode.

12. The medical device system of claim 1 wherein the first elongate member includes an edge interrupted by a notch, the notch located to expose at least a portion of at least a second electrode located on the second elongate member as viewed towards the second electrode along a direction parallel to a direction that the first axis extends along when the structure is in the deployed configuration.

13. The medical device system of claim 12 wherein the second group of the electrodes includes the second electrode.

14. The medical device system of claim 12 wherein the second electrode is adjacent the first electrode when the structure is in the deployed configuration.

15. The medical device system of claim 1 wherein the first elongate member includes a surface interrupted by a channel, the channel located to expose at least a portion of at least a second electrode located on the second elongate member as viewed towards the second electrode along a direction parallel to a direction that the first axis extends along when the structure is in the deployed configuration.

16. The medical device system of claim 1 wherein the first elongate member includes a jogged portion, wherein the jogged portion undergoes at least one change in direction as the jogged portion extends between the proximal and the distal ends of the first elongate member, and the jogged portion is located to expose at least a portion of at least a second electrode located on the second elongate member as viewed towards the second electrode along a direction parallel to a direction that the first axis extends along when the structure is in the deployed configuration.

17. The medical device system of claim 1 wherein each of the plurality of elongate members is arranged to be advanced distal end ahead of proximal end toward the bodily cavity when the structure is in the delivery configuration.

18. The medical device system of claim 1 wherein the intermediate portion of the first elongate member is adjacent the intermediate portion of the second elongate member when the structure is in the deployed configuration.

19. The medical device system of claim 1 wherein the first group of the electrodes includes a pair of adjacent ones of the electrodes located on the first elongate member.

20. The medical device system of claim 19 wherein a region of space associated with a physical portion of the structure is located between the respective electrodes of the pair of adjacent ones of the electrodes located on the first elongate member, the region of space intersected by the first plane when the structure is in the deployed configuration.

21. The medical device system of claim 1 wherein the respective electrodes of the first group of the electrodes are spaced along a length of a portion of the first elongate member, the length of the portion of the first elongate member extending along the first elongate member between the proximal and the distal ends of the first elongate member, the entirety of the length of the portion of the elongate member intersected by the first plane when the structure is in the deployed configuration.

22. The medical device system of claim 1 wherein the first group of the electrodes, the second group of the electrodes, or each of both the first and the second groups of the electrodes includes three or more of the plurality of electrodes.

23. The medical device system of claim 1 wherein the first plane intersects every electrode that is located on the first elongate member when the structure is in the deployed configuration.

24. The medical device system of claim 23 wherein the second plane intersects every electrode that is located on the second elongate member when the structure is in the deployed configuration.

25. The medical device system of claim 1 wherein the first group of the electrodes includes the first electrode and the second group of the electrodes does not include the first electrode.

26. The medical device system of claim 1 wherein: the intermediate portion of each elongate member of the plurality of elongate members comprises a front surface and a back surface opposite across a thickness of the elongate member from the front surface, each intermediate portion further comprising a respective pair of side edges of the front surface, the back surface, or both the front surface and the back surface of the intermediate portion, the side edges of each pair of side edges opposite to one another, each of the side edges of each pair of side edges extending between the proximal end and the distal end of the respective elongate member, and

the first elongate member is positioned such that a first side edge of the pair of side edges of the first elongate member crosses a second side edge of the pair of side edges of the second elongate member of the plurality of elongate members when the structure is in the deployed configuration, a portion of the first side edge forming a recessed portion of the first elongate member that exposes at least a portion of a second electrode located on a portion of the front surface of the second elongate member as viewed normally to the portion of the front surface of the second elongate member when the structure is in the deployed configuration.

27. The medical device system of claim 26 wherein the second group of the electrodes includes the second electrode.

28. The medical device system of claim 1 wherein each of the respective intermediate portions of the elongate members each comprises a thickness, a front surface, and a back surface opposite across the thickness from the front surface, and wherein at least the respective intermediate portions of at least three elongate members of the plurality of elongate members are arrayed along a first direction front surface-toward-back surface in a stacked array when the structure is in the delivery configuration.

29. The medical device system of claim 28 wherein the structure further comprises a proximal portion and a distal portion, each of the proximal and the distal portions comprising a respective part of each of the plurality of elongate members, the proximal portion of the structure forming a first domed shape and the distal portion of the structure forming a second domed shape when the structure is in the deployed configuration.

30. The medical device system of claim 1 wherein: the structure includes a proximal portion and a distal portion, the structure is arranged to be advanced distal portion ahead of proximal portion toward the bodily cavity when the structure is in the delivery configuration, and the proximal portion of the structure forms a first domed shape and the distal portion of the structure forms a second domed shape when the structure is in the deployed configuration, the proximal and the distal

portions of the structure arranged in a clam shell configuration when the structure is in the deployed configuration.

31. The medical device system of claim 1 wherein the intermediate portions of at least some of the plurality of elongate members are, when the structure is in the deployed configuration, sufficiently spaced from the first axis to position each of at least some of the plurality of the electrodes at respective locations suitable for contact with a tissue wall of the bodily cavity.

32. The medical device system of claim 1 comprising a controller and an energy source device system, the controller communicatively connected to the energy source device system, and the energy source device system connected to the plurality of electrodes, wherein the controller is configured to cause, via the energy source device system, each of at least one electrode of the plurality of electrodes to deliver energy when the structure is in the deployed configuration.

33. The medical device system of claim 32 wherein the controller is configured to cause each of at least a particular electrode of the plurality of electrodes to sense a characteristic when the structure is in the deployed configuration.

34. The medical device system of claim 32 wherein the controller is configured to cause each of the at least one electrode to receive energy when the structure is in the deployed configuration.

35. The medical device system of claim 32 wherein the controller is configured to cause each of the at least one electrode to sense a characteristic of tissue in the bodily cavity when the structure is in the bodily cavity in the deployed configuration.

36. The medical device system of claim 32 wherein the energy is sufficient for tissue ablation.

37. The medical device system of claim 1 comprising a controller communicatively connected to the plurality of electrodes, wherein the controller is configured to cause each of at least one electrode of the plurality of electrodes to ablate tissue in the bodily cavity when the structure is positioned in the bodily cavity in the deployed configuration.

38. A medical device system comprising:

a plurality of transducers positionable in a bodily cavity and a structure on which the transducers are located, the structure comprising a plurality of elongate members, each of the elongate members comprising a proximal end, a distal end, an intermediate portion positioned between the proximal end and the distal end, and a thickness, each intermediate portion comprising a front surface and a back surface opposite across the thickness of the elongate member from the front surface, and each intermediate portion further comprising a respective pair of side edges of the front surface, the back surface, or both the front surface and the back surface, the side edges of each pair of side edges opposite to one another, the side edges of each pair of side edges extending between the proximal end and the distal end of the respective elongate member, wherein the structure is selectively moveable between:

a delivery configuration in which the structure is sized for percutaneous delivery to a bodily cavity, and

a deployed configuration in which the structure is sized too large for percutaneous delivery to the bodily cavity, at least a first elongate member of the plurality of elongate members positioned such that a first side edge of the pair of side edges of the first elongate member crosses a second side edge of the pair of side edges of a second elongate member of the plurality of elongate

members when the structure is in the deployed configuration, a portion of the first side edge forming a recessed portion of the first elongate member that exposes at least a portion of a transducer located on a portion of the front surface of the second elongate member as viewed normally to the portion of the front surface of the second elongate member when the structure is in the deployed configuration.

39. The medical device system of claim 38 wherein the recessed portion of the first elongate member forms at least a portion of a notch in the intermediate portion of the first elongate member, the notch extending towards a second side edge of the pair of side edges of the first elongate member.

40. The medical device system of claim 38 wherein the first elongate member includes a jogged portion, the jogged portion undergoing at least one change in direction as the jogged portion extends between the proximal and the distal ends of the first elongate member, the recessed portion of the first elongate member forming at least part of the jogged portion.

41. The medical device system of claim 38 wherein the intermediate portions of the elongate members are angularly arranged with respect to one another about an axis when the structure is in the deployed configuration.

42. The medical device system of claim 38 wherein at least some of the plurality of transducers are radially spaced about an axis when the structure is in the deployed configuration.

43. The medical device system of claim 38 wherein at least some of the plurality of transducers are circumferentially arranged about an axis when the structure is in the deployed configuration.

44. The medical device system of claim 38 wherein at least some of the plurality of transducers are arranged in a plurality of concentric ringed arrangements when the structure is in the deployed configuration, a first one of the plurality of concentric ringed arrangements having a fewer number of the transducers than a second one of the plurality of concentric ringed arrangements.

45. The medical device system of claim 44 wherein the first one of the plurality of concentric ringed arrangements does not include any of the plurality of transducers located on the second elongate member.

46. The medical device system of claim 45 wherein the second one of the plurality of concentric ringed arrangements includes the transducer located on the portion of the front surface of the second elongate member.

47. The medical device system of claim 46 wherein the first one of the plurality of concentric ringed arrangements is adjacent the second one of the plurality of concentric ringed arrangements.

48. The medical device system of claim 38 wherein each of the plurality of elongate members is arranged to be advanced distal end ahead of proximal end toward the bodily cavity when the structure is in the delivery configuration.

49. The medical device system of claim 38 wherein the respective intermediate portions of the plurality of elongate members are arranged front surface-toward-back surface in a stacked array when the structure is in the delivery configuration.

50. The medical device system of claim 49 wherein the structure further comprises a proximal portion and a distal portion, each of the proximal and the distal portions comprising a respective part of each of the plurality of elongate members, the proximal portion of the structure forming a

first domed shape and the distal portion of the structure forming a second domed shape when the structure is in the deployed configuration.

51. The medical device system of claim 38 wherein: the structure includes a proximal portion and a distal portion, the structure is arranged to be advanced distal portion ahead of proximal portion toward the bodily cavity when the structure is in the delivery configuration, and the proximal portion of the structure forms a first domed shape and the distal portion of the structure forms a second domed shape when the structure is in the deployed configuration, the proximal and the distal portions of the structure arranged in a clam shell configuration when the structure is in the deployed configuration.

52. The medical device system of claim 38 comprising a controller and an energy source device system, the controller communicatively connected to the energy source device system, and the energy source device system connected to the plurality of transducers, wherein the controller is configured to cause, via the energy source device system, each of at least one transducer of the plurality of transducers to deliver energy when the structure is in the deployed configuration.

53. The medical device system of claim 52 wherein the energy is sufficient for tissue ablation.

54. The medical device system of claim 52 wherein the controller is configured to cause each of at least a particular transducer of the plurality of transducers to sense a characteristic when the structure is in the deployed configuration.

55. The medical device system of claim 52 wherein the controller is configured to cause each of the at least one transducer to receive energy when the structure is in the deployed configuration.

56. The medical device system of claim 52 wherein the controller is configured to cause each of the at least one transducer to sense a characteristic of tissue in the bodily cavity when the structure is in the bodily cavity in the deployed configuration.

57. The medical device system of claim 38 comprising a controller communicatively connected to the plurality of transducers, wherein the controller is configured to cause each of the at least one transducer of the plurality of transducers to ablate tissue in the bodily cavity when the structure is in the bodily cavity in the deployed configuration.

58. A method comprising: providing a medical device system including a structure and a plurality of electrodes located on the structure, the structure including a plurality of elongate members, each of the elongate members including a proximal end, a distal end, and an intermediate portion between the proximal end and the distal end, a first group of electrodes of the plurality of electrodes located on a first elongate member of the plurality of elongate members, and a second group of electrodes of the plurality of electrodes located on a second elongate member of the plurality of elongate members;

moving the structure from a delivery configuration in which the structure is sized to be percutaneously deliverable to a bodily cavity and a deployed configuration in which the structure is expanded to have a size too large to be percutaneously deliverable to the bodily cavity, wherein the intermediate portions of the elongate members are angularly arranged with respect to one another about a first axis when the structure is in

the deployed configuration, each electrode of the first group of electrodes intersected by a first plane having no thickness, and each electrode of the second group of electrodes intersected by a second plane having no thickness when the structure is in the deployed configuration, wherein the first and the second planes are non-parallel planes that intersect each other along a second axis, wherein at least a first electrode of the plurality of electrodes is intersected by each of the first plane and the second plane when the structure is in the deployed configuration, the first electrode not intersected by each of the first axis and the second axis when the structure is in the deployed configuration; and operating each of at least one electrode of the plurality of electrodes to deliver energy when the structure is in the deployed configuration.

59. The method of claim 58 wherein the energy is sufficient for tissue ablation.

60. The method of claim 58 comprising percutaneously delivering the structure to the bodily cavity when the structure is in the delivery configuration, and operating each of the at least one electrode to ablate tissue in the bodily cavity when the structure is in the deployed configuration.

61. The method of claim 58 comprising operating each of at least a particular electrode of the plurality of electrodes to sense a characteristic when the structure is in the deployed configuration.

62. The method of claim 58 comprising operating each of the at least one electrode to receive energy when the structure is in the deployed configuration.

63. The method of claim 58 comprising: percutaneously delivering the structure to the bodily cavity when the structure is in the delivery configuration; and

operating each of the at least one electrode to sense a characteristic of tissue in the bodily cavity when the structure is in the deployed configuration.

64. A method comprising: providing a medical device system including a plurality of transducers positionable in a bodily cavity and a structure on which the transducers are located, the structure including a plurality of elongate members, each of the elongate members comprising a proximal end, a distal end, an intermediate portion positioned between the proximal end and the distal end, and a thickness, each intermediate portion comprising a front surface and a back surface opposite across the thickness of the elongate member from the front surface, and each intermediate portion further comprising a respective pair of side edges of the front surface, the back surface, or both the front surface and the back surface, the side edges of each pair of side edges opposite to one another, the side edges of each pair of side edges extending between the proximal end and the distal end of the respective elongate member; and

moving the structure from a delivery configuration, in which the structure is sized to be percutaneously deliverable to the bodily cavity, to a deployed configuration, in which the structure is sized too large to be percutaneously deliverable to the bodily cavity,

wherein at least a first elongate member of the plurality of elongate members is positioned with a first side edge of the pair of side edges of the first elongate member crossing a second side edge of the pair of side edges of a second elongate member of the plurality of elongate members when the structure is in the deployed configuration, the moving causing, via a recessed portion

of the first side edge of the first elongate member, at least a portion of a transducer located on a portion of the front surface of the second elongate member to be exposed as viewed normally to the portion of the front surface of the second elongate member when the structure is in the deployed configuration. 5

65. The method of claim 64 comprising operating each of at least one transducer of the plurality of transducers to deliver energy when the structure is in the deployed configuration. 10

66. The method of claim 65 comprising operating each of at least a particular transducer of the plurality of transducers to sense a characteristic when the structure is in the deployed configuration.

67. The method of claim 65 comprising operating each of the at least one transducer to receive energy when the structure is in the deployed configuration. 15

68. The method of claim 65 comprising:  
percutaneously delivering the structure to the bodily cavity when the structure is in the delivery configuration; 20  
and

operating each of the at least one transducer to sense a characteristic of tissue in the bodily cavity when the structure is in the deployed configuration.

69. The method of claim 65 wherein the energy is sufficient for tissue ablation. 25

70. The method of claim 64 comprising percutaneously delivering the structure to the bodily cavity when the structure is in the delivery configuration, and operating each of the at least one transducer to ablate tissue in the bodily cavity when the structure is in the deployed configuration. 30

\* \* \* \* \*

专利名称(译)	基于高密度电极的医疗器械系统		
公开(公告)号	<a href="#">US9486273</a>	公开(公告)日	2016-11-08
申请号	US13/793076	申请日	2013-03-11
[标]申请(专利权)人(译)	卡尔蒂姆公司		
当前申请(专利权)人(译)	KARDIUM INC.		
[标]发明人	LOPES FERNANDO LUIS DE SOUZA MOISA SAAR HAWES PETER JOSIAH		
发明人	LOPES, FERNANDO LUIS DE SOUZA MOISA, SAAR HAWES, PETER JOSIAH		
IPC分类号	A61B5/042 A61B5/04 A61B18/14 A61B5/00 A61B5/053 A61N1/05 A61B18/00		
CPC分类号	A61B18/14 A61B5/04 A61B5/0422 A61B5/6858 A61B18/1492 A61B5/0538 A61B5/6885 A61B2018/00267 A61B2018/00357 A61B2018/00577 A61B2018/1467 A61B2562/0209 A61B2562/0271 A61B2562/046 A61N1/056 A61B5/042 A61B2018/0016 A61B2018/00208 A61B2018/1407 A61B2018/1417 A61B2018/1475 A61B2562/04		
优先权	61/723311 2012-11-06 US 61/670881 2012-07-12 US 61/649734 2012-05-21 US 61/734750 2012-12-07 US 61/435213 2011-01-21 US 61/485987 2011-05-13 US 61/488639 2011-05-20 US 61/515141 2011-08-04 US		
其他公开文献	US20130197513A1		
外部链接	<a href="#">Espacenet</a> <a href="#">USPTO</a>		

摘要(译)

公开了一种医疗设备系统，其包括高密度布置的换能器，其可以被配置成消融，刺激或感测身体腔内的组织特征，例如心内腔。特别是考虑到细长构件的重叠，可以至少部分地通过重叠细长构件实现换能器的高密度布置，换能器位于换能器上的细长构件以及换能器的不同尺寸，形状或两者。此外，换能器的高密度布置可以至少部分地通过在细长构件中包括一个或多个凹陷部分来实现，以便在邻近细长构件的区域中暴露下面的细长构件上的一个或多个换能器 - 重叠区域。

