



US 20170215762A1

(19) **United States**

(12) **Patent Application Publication**
Burnside et al.

(10) **Pub. No.: US 2017/0215762 A1**

(43) **Pub. Date: Aug. 3, 2017**

(54) **MULTIPLE COIL SYSTEM FOR TRACKING
A MEDICAL DEVICE**

(71) Applicant: **C. R. Bard, Inc.**, Murray Hill, NJ (US)

(72) Inventors: **Eddie K. Burnside**, Bountiful, UT
(US); **Shayne Messerly**, Kaysville, UT
(US)

(21) Appl. No.: **15/418,475**

(22) Filed: **Jan. 27, 2017**

Related U.S. Application Data

(60) Provisional application No. 62/289,126, filed on Jan. 29, 2016.

Publication Classification

(51) **Int. Cl.**
A61B 5/06 (2006.01)
A61B 5/00 (2006.01)
A61B 90/00 (2006.01)
A61B 5/055 (2006.01)

(52) **U.S. Cl.**
CPC *A61B 5/066* (2013.01); *A61B 5/055*
(2013.01); *A61B 5/742* (2013.01); *A61B*
5/6852 (2013.01); *A61B 5/6848* (2013.01);
A61B 90/39 (2016.02); *A61B 2560/0223*
(2013.01); *A61B 2560/0214* (2013.01); *A61B*
2090/3908 (2016.02); *A61B 2090/3958*
(2016.02)

(57) **ABSTRACT**

A system for tracking the position of one or more medical devices for insertion into the body of a patient is disclosed. The system may also be used to locate one or medical devices at a later time after placement thereof. The present system employs multiple radiating elements that can be simultaneously detected by a sensor unit of the system, wherein at least one of the radiating elements is included with the medical device. Another of the radiating elements may be placed at a predetermined point on the skin of the patient to serve as a landmark to help determine the location of the medical device with respect to the landmark. Detection of the radiating elements by the sensor unit enables the relative positions of the radiating elements to be ascertained and depicted on a display, to assist a clinician in accurately positioning the medical device, such as a catheter.

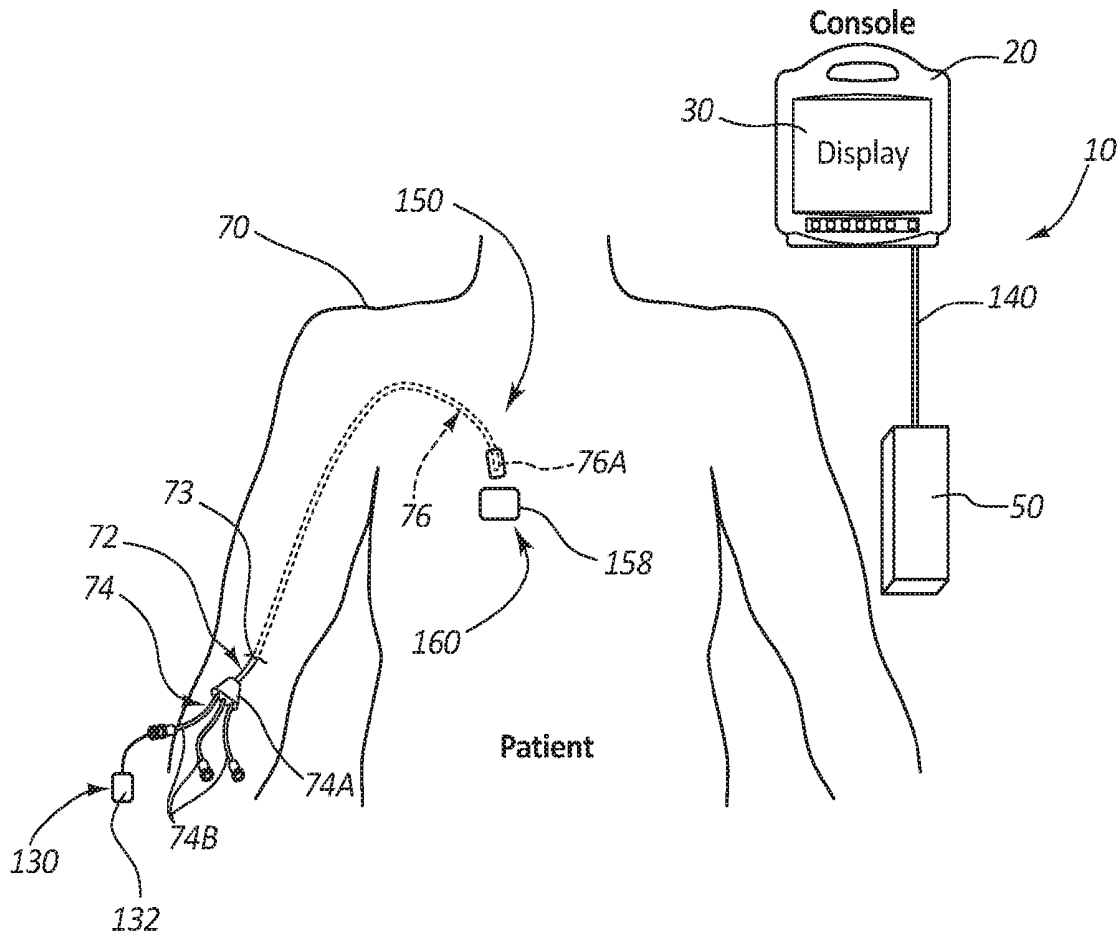

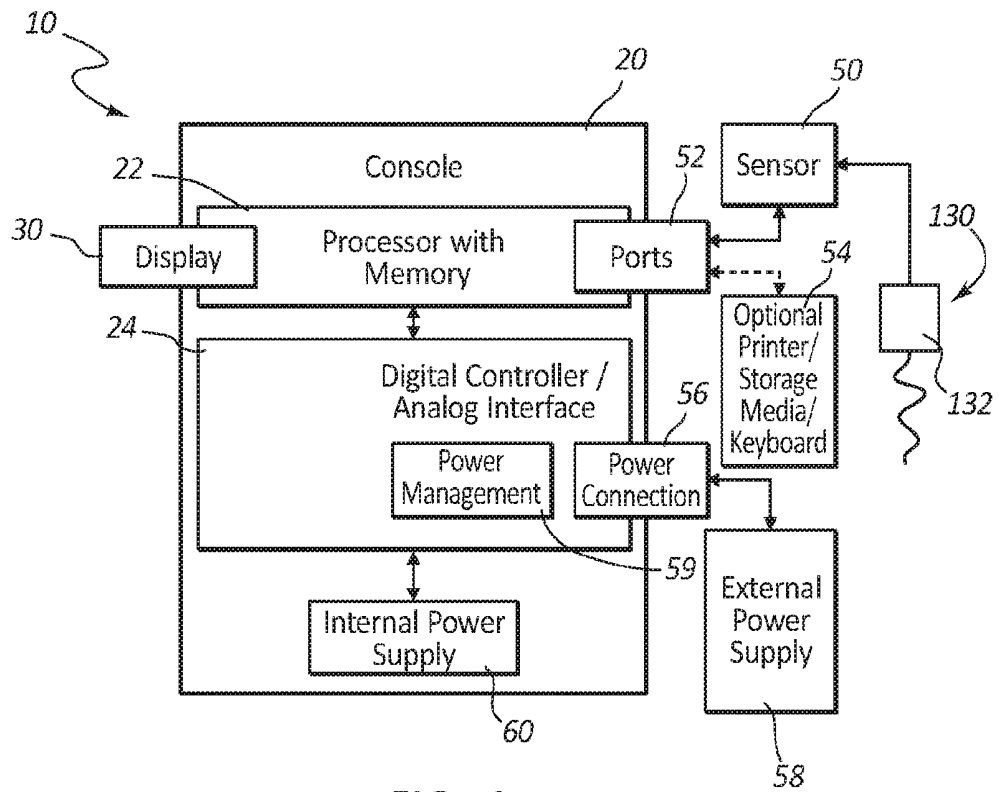

FIG. 1

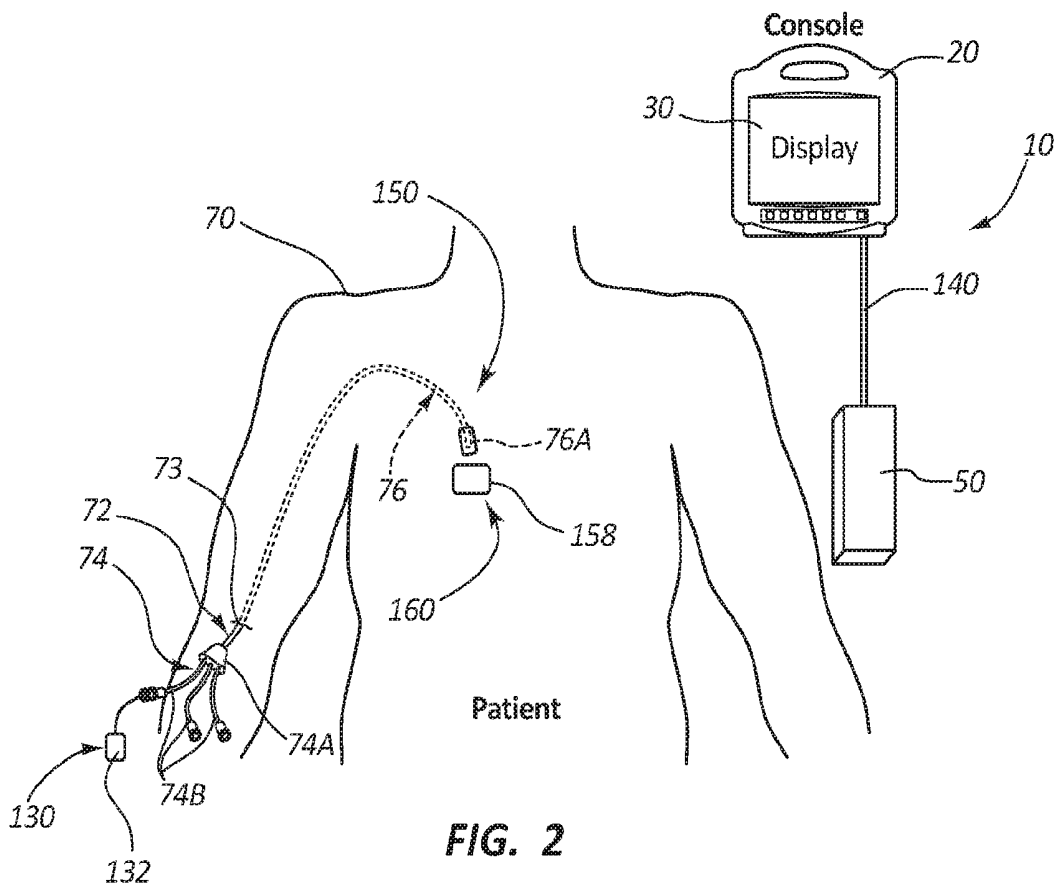

FIG. 2

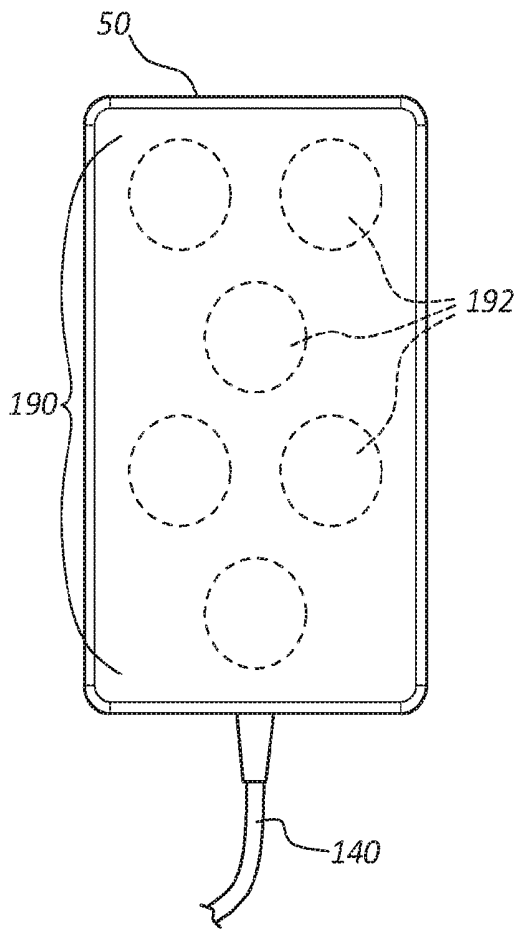

FIG. 3A

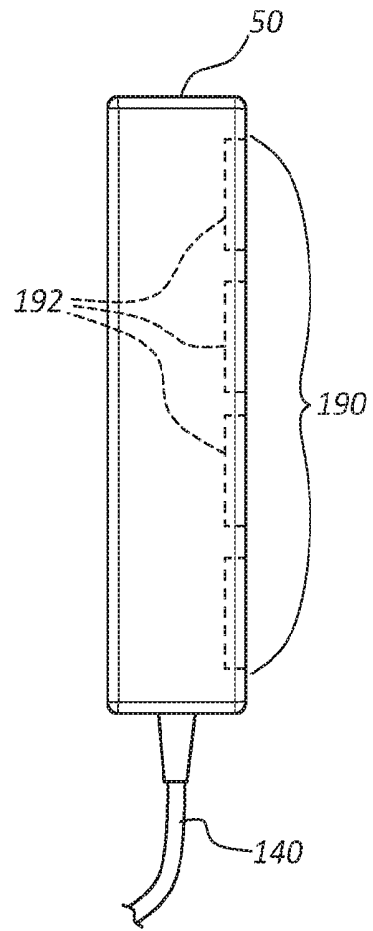

FIG. 3B

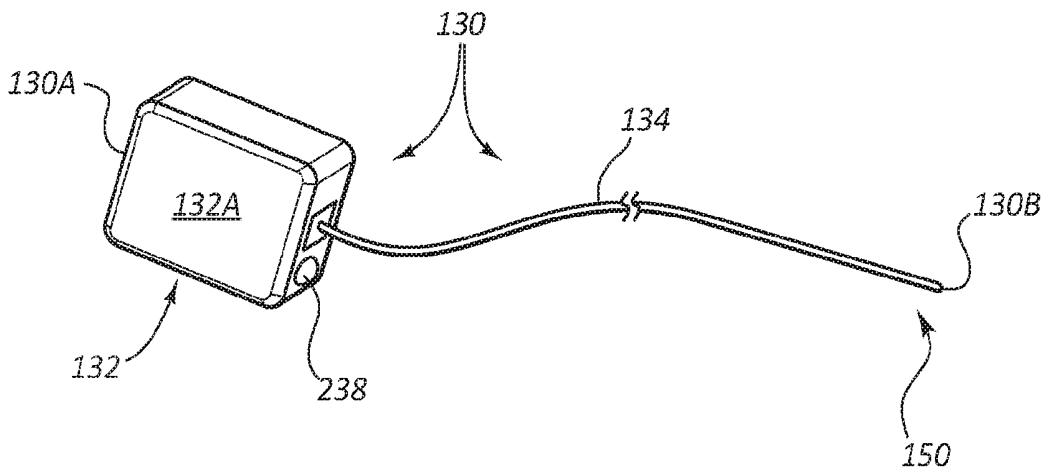

FIG. 4

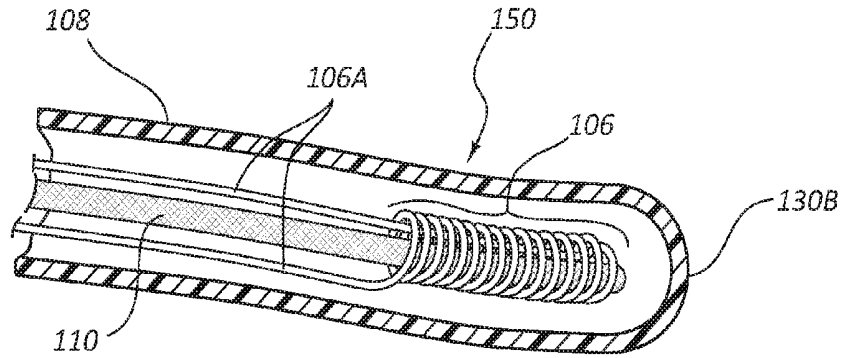

FIG. 5

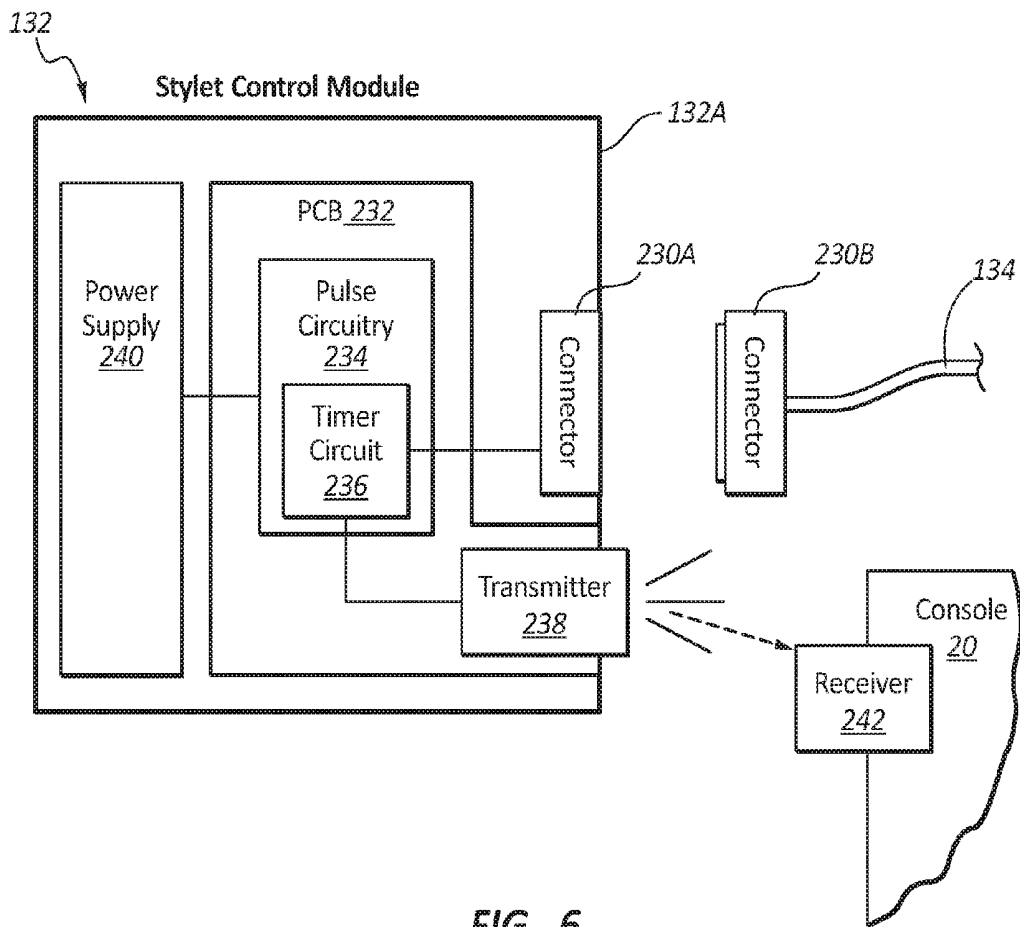

FIG. 6

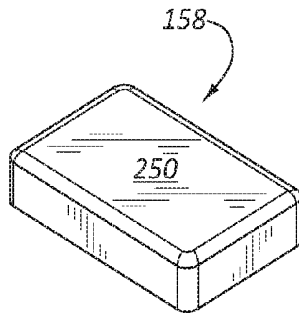

FIG. 7A

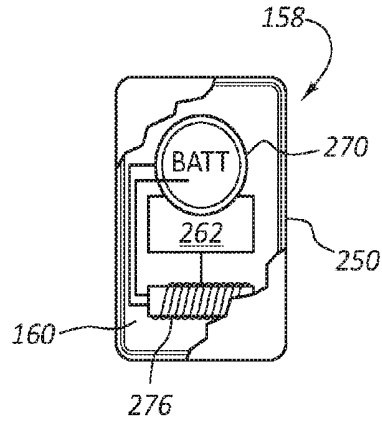

FIG. 7B

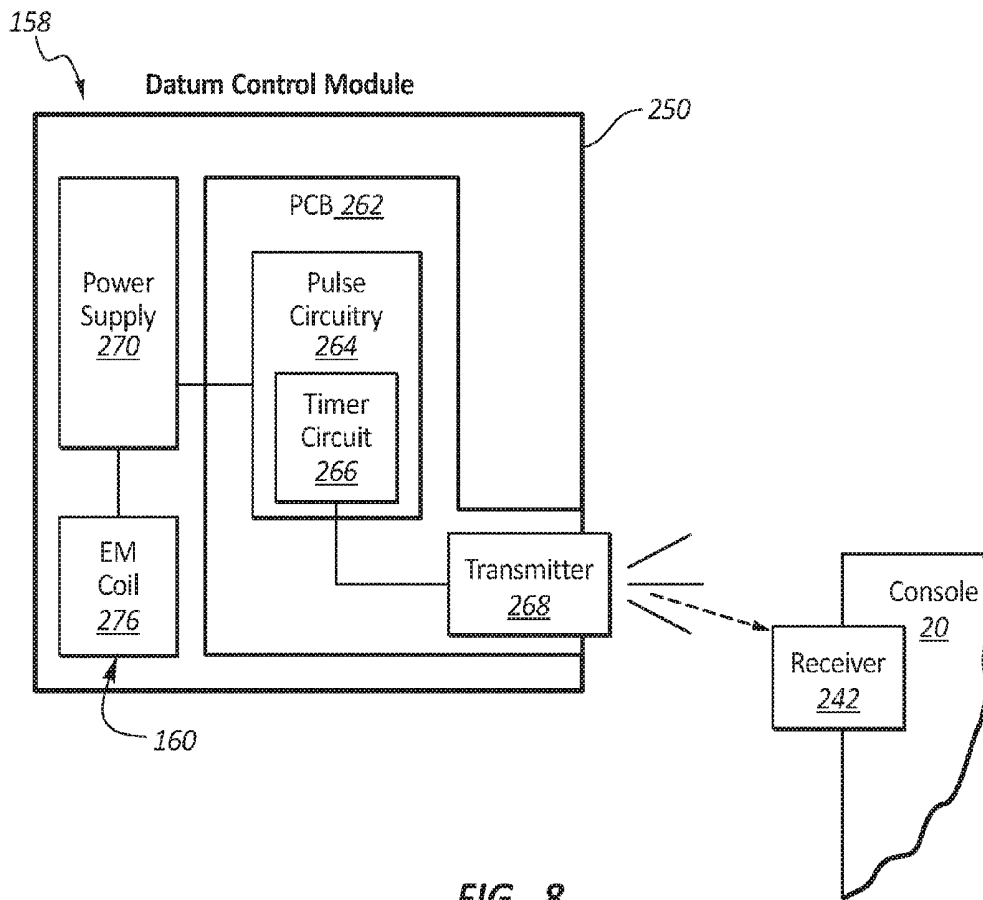

FIG. 8

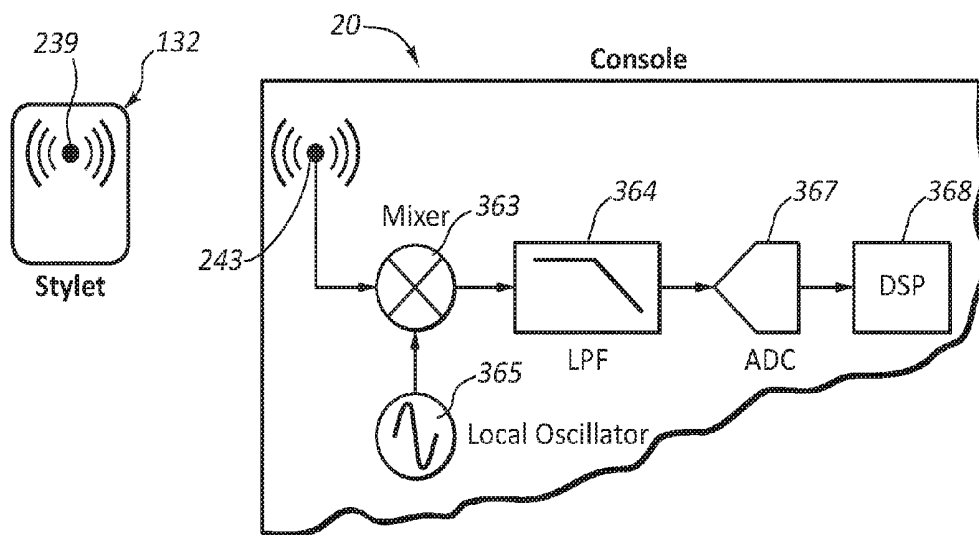

FIG. 9

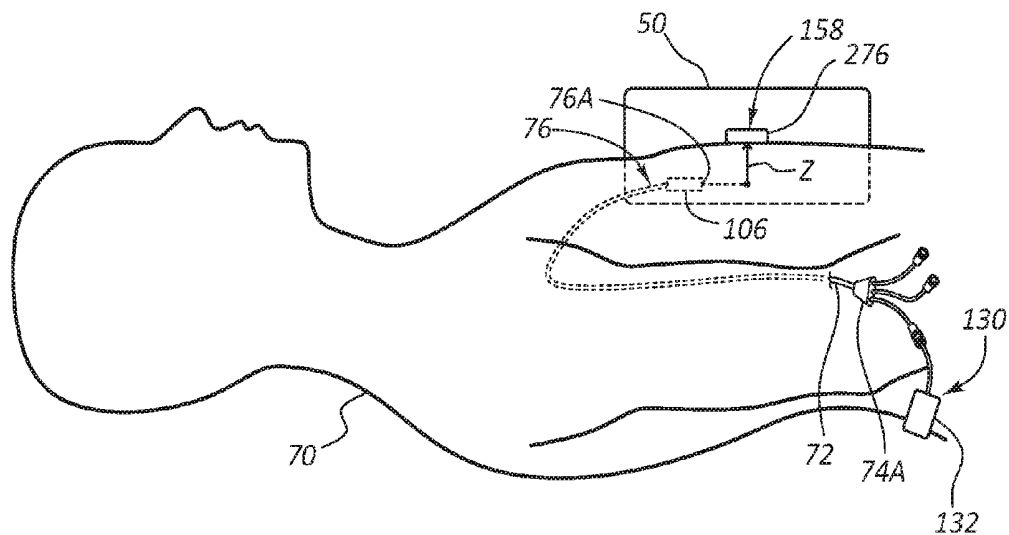

FIG. 10

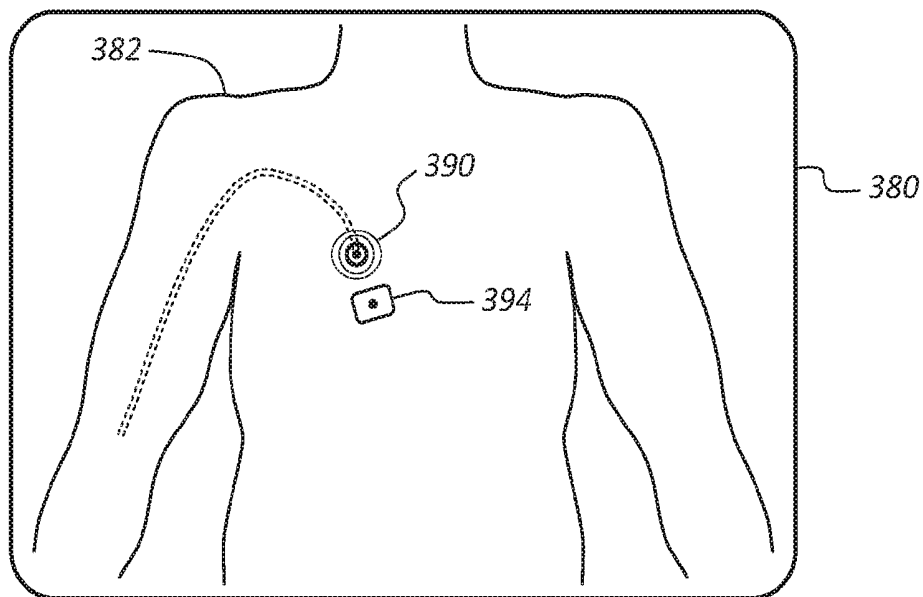

FIG. 11

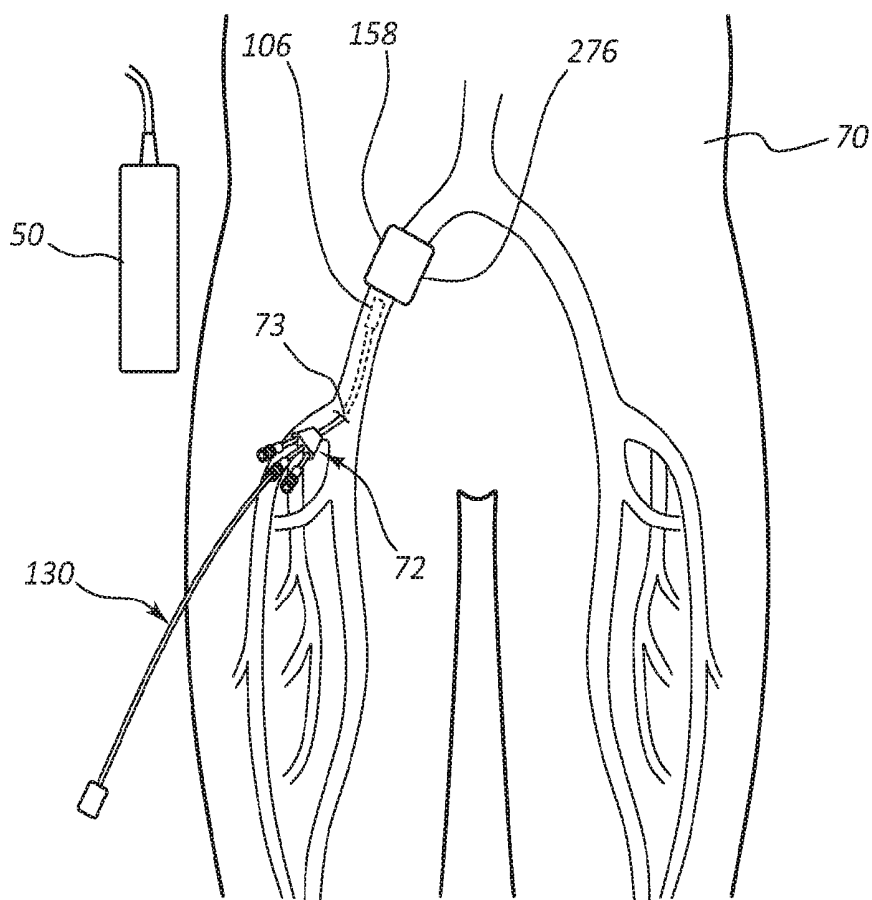

FIG. 12

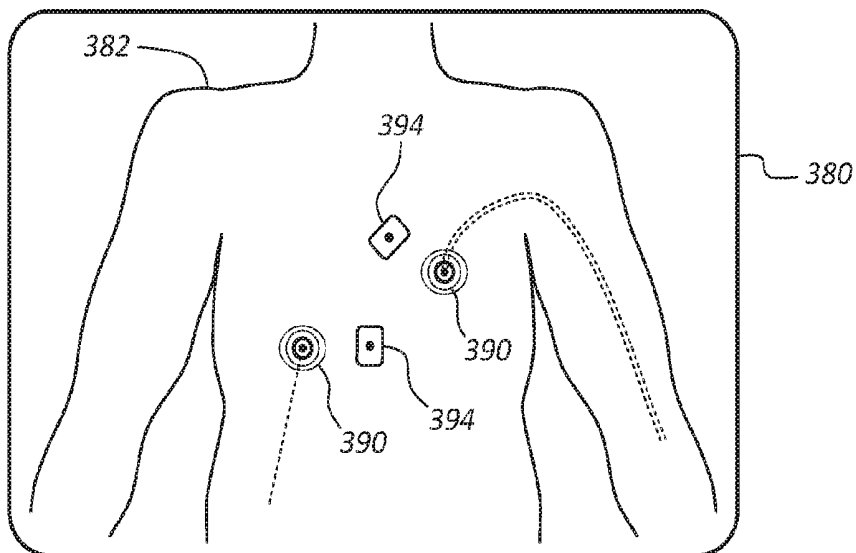

FIG. 13

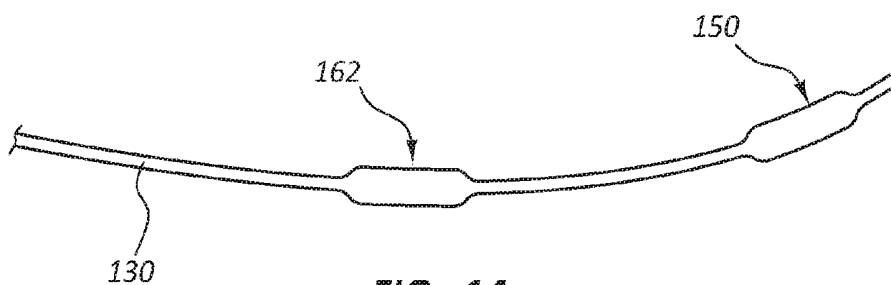

FIG. 14

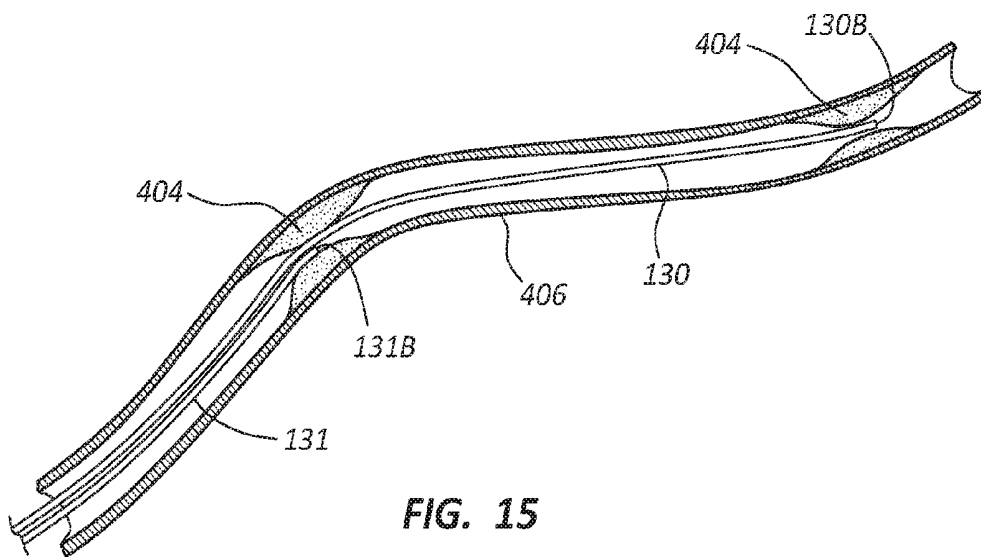

FIG. 15

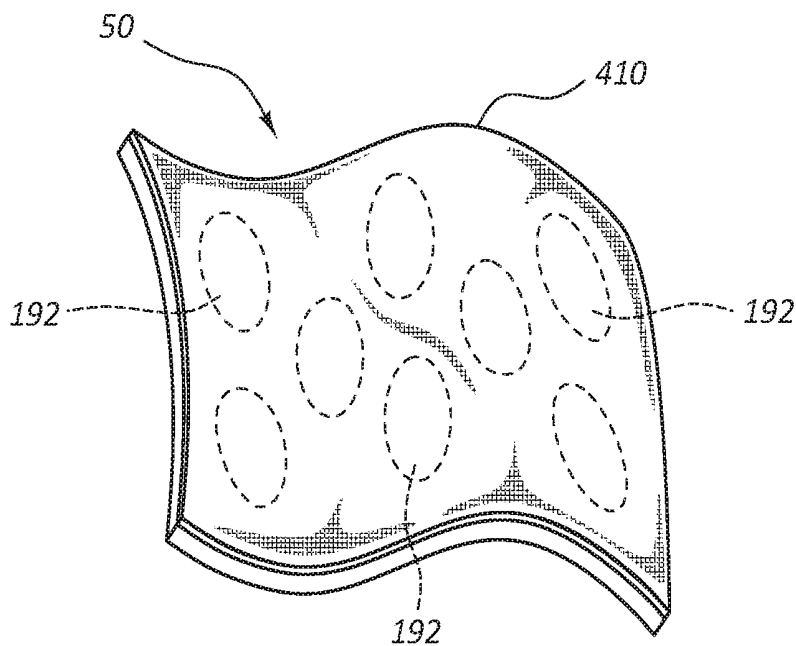

FIG. 16

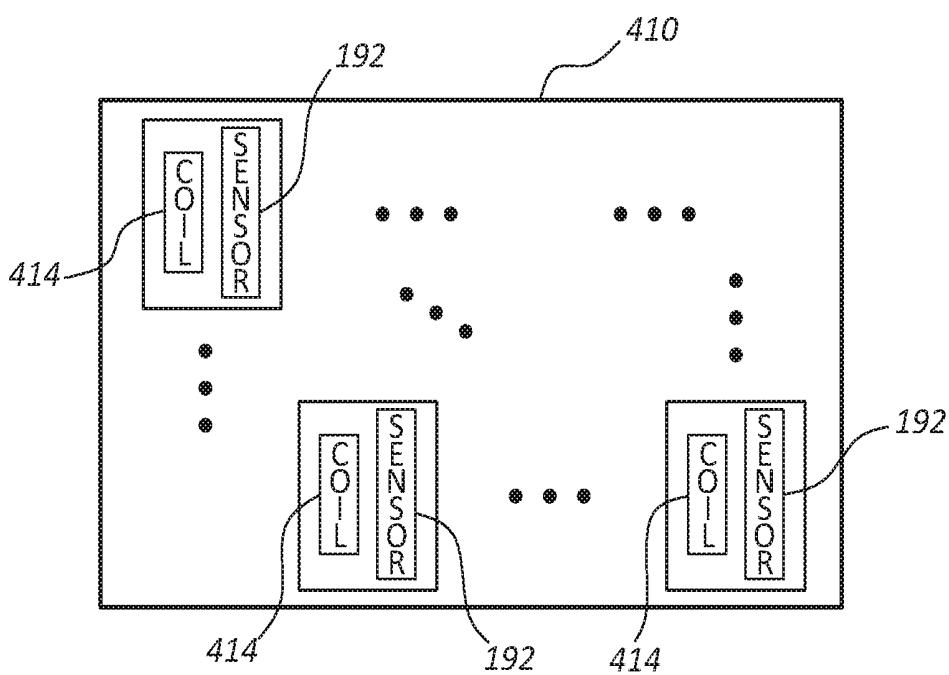
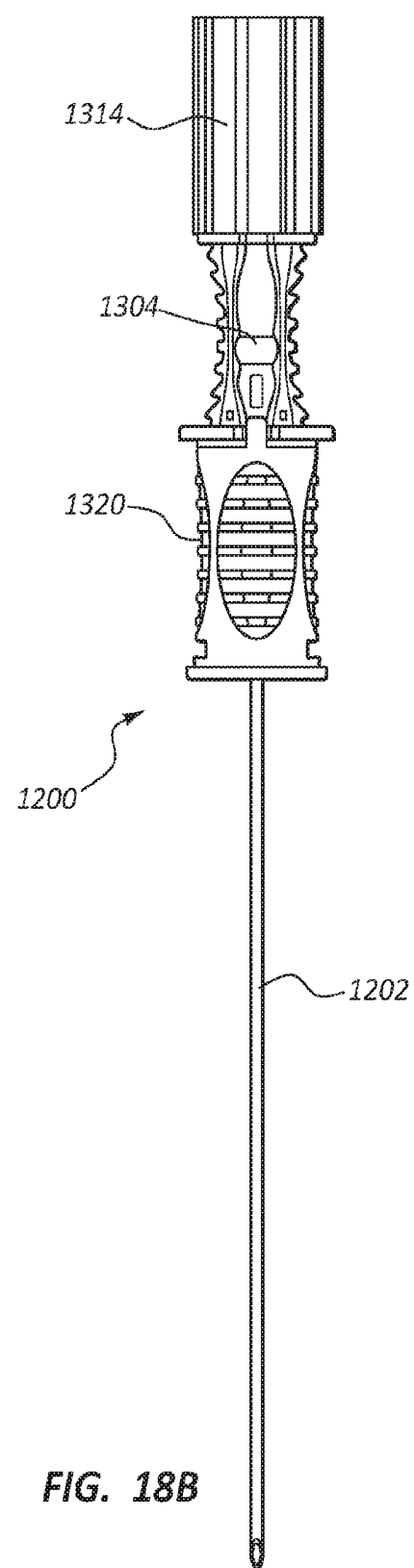
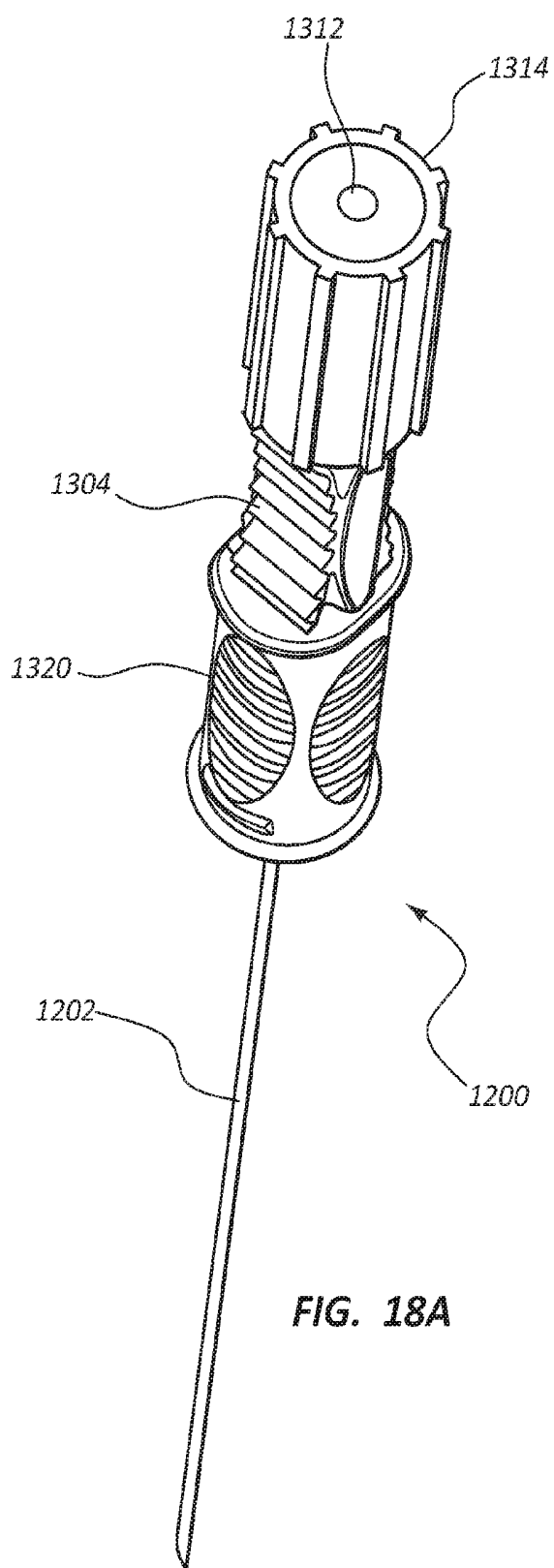
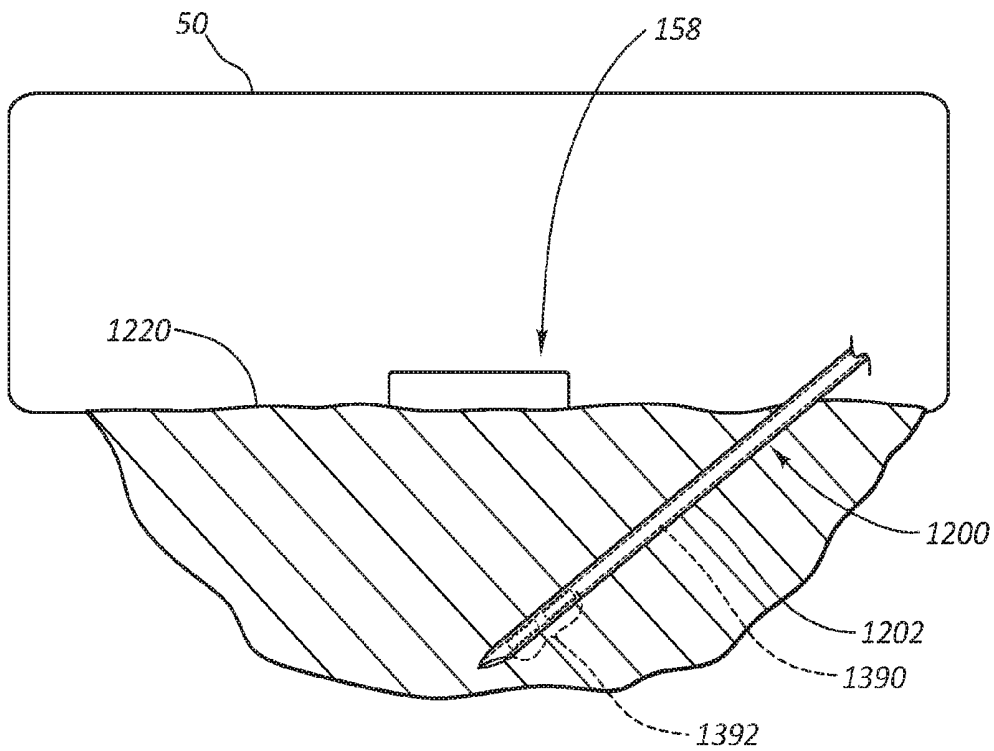
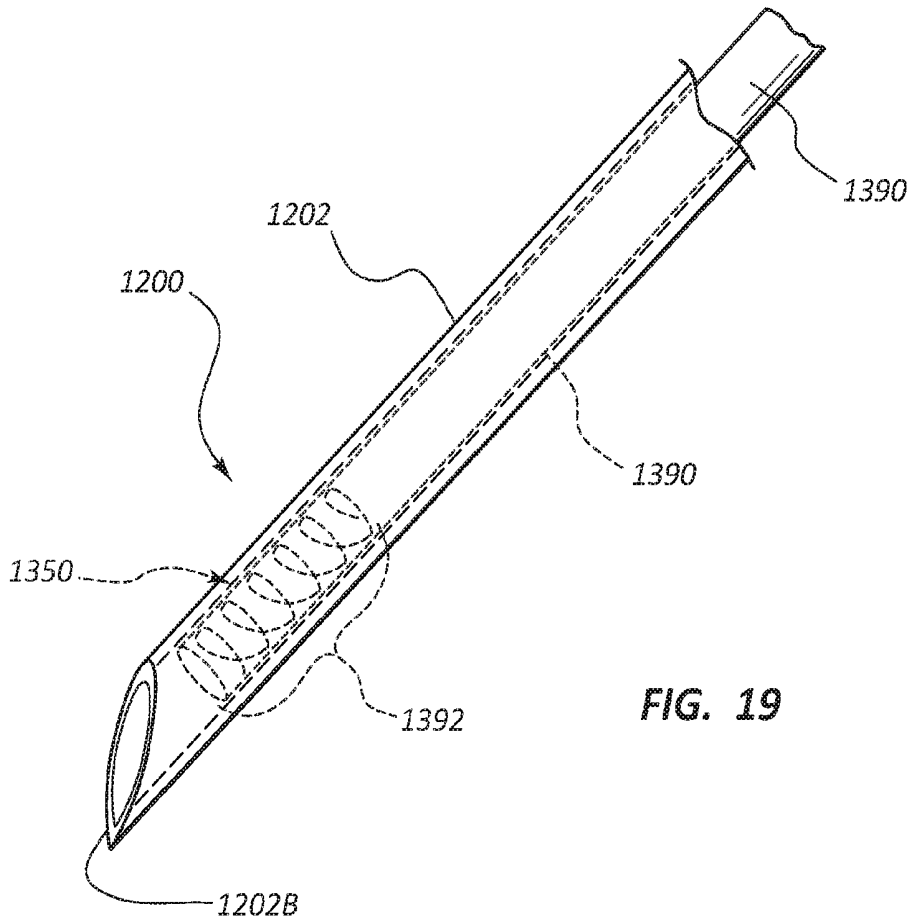

FIG. 17





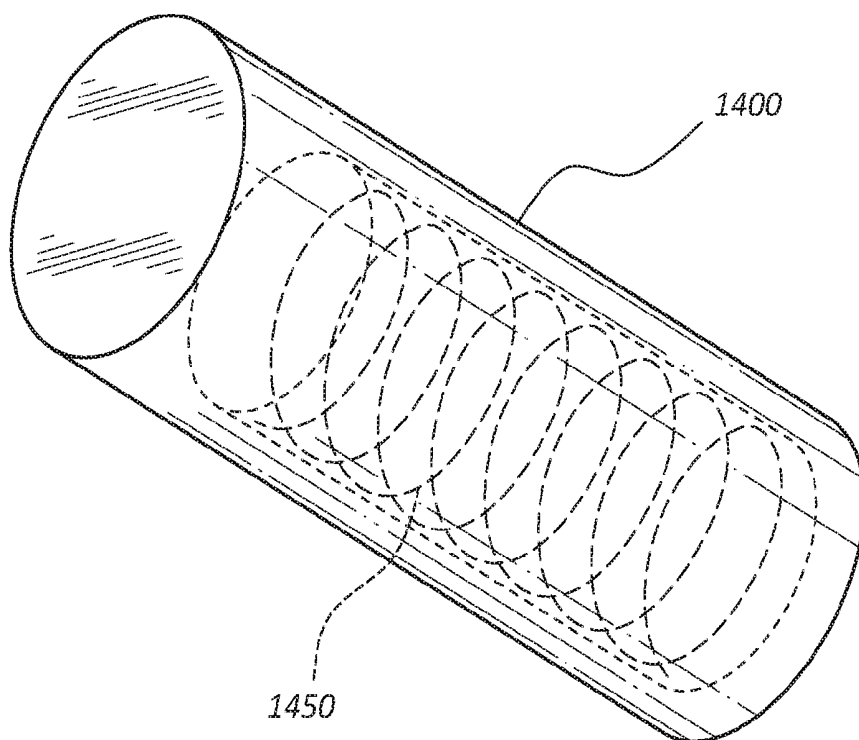

FIG. 21

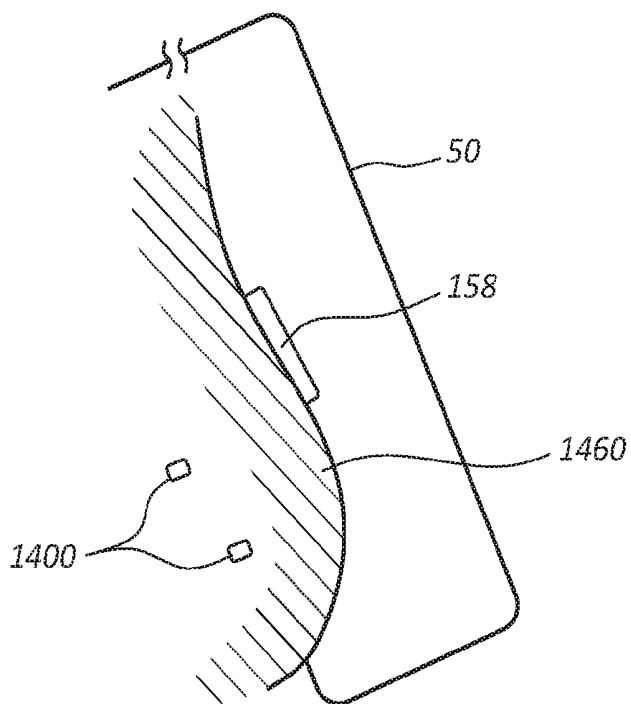

FIG. 22

MULTIPLE COIL SYSTEM FOR TRACKING A MEDICAL DEVICE

CROSS-REFERENCE TO RELATED APPLICATIONS

[0001] This application claims the benefit of U.S. Provisional Patent Application No. 62/289,126, filed Jan. 29, 2016, and titled "Multiple Coil System for Tracking an Indwelling Medical Device," which is incorporated herein by reference in its entirety.

BRIEF SUMMARY

[0002] Briefly summarized, embodiments of the present invention are directed to a system for tracking the position of one or more medical devices for at least partial insertion into and/or advancement within the body of a patient. The system may also be used to locate one or medical devices at a later time after placement thereof.

[0003] The present system includes the use of multiple radiating elements that can be simultaneously detected by a sensor unit of the system, wherein at least one of the radiating elements is included with the medical device, in one embodiment. Another of the radiating elements may be placed at a predetermined point on the skin of the patient to serve as a landmark to help determine the location of the medical device with respect to the landmark.

[0004] Detection of the radiating elements by the sensor unit enables the relative positions of the radiating elements to be ascertained and depicted on a display, including two and/or three-dimensional depictions, so as to in turn enable a clinician to observe the relative position of the medical device(s) and landmarks. This assists the clinician in positioning the medical device in a desired position within the patient body.

[0005] In one embodiment, therefore, a system for tracking a medical device with respect to a body of a patient is disclosed, comprising a display and a first radiating element. The first radiating element is included with the medical device and is capable of producing a first electromagnetic field. A second radiating element capable of producing a second electromagnetic field is also disclosed and is positioned with respect to the body of the patient. A sensor unit is operably connected to the display, wherein the display is configured for depiction of information relating to detection by the sensor unit of the first and second electromagnetic fields of the first and second radiating elements.

[0006] These and other features of embodiments of the present invention will become more fully apparent from the following description and appended claims, or may be learned by the practice of embodiments of the invention as set forth hereinafter.

BRIEF DESCRIPTION OF THE DRAWINGS

[0007] A more particular description of the present disclosure will be rendered by reference to specific embodiments thereof that are illustrated in the appended drawings. It is appreciated that these drawings depict only typical embodiments of the invention and are therefore not to be considered limiting of its scope. Example embodiments of the invention will be described and explained with additional specificity and detail through the use of the accompanying drawings in which:

[0008] FIG. 1 is a block diagram depicting various elements of an integrated system for intravascular placement of a catheter or other medical device, according to one example embodiment of the present invention;

[0009] FIG. 2 is a simplified view of a patient and a catheter being inserted therein with assistance of the integrated system of FIG. 1;

[0010] FIGS. 3A and 3B depict various views of the sensor unit of the system of FIG. 1;

[0011] FIG. 4 is a perspective view of an untethered stylet configured in accordance with one embodiment;

[0012] FIG. 5 is a cross sectional view of a distal portion of the stylet of FIG. 4;

[0013] FIG. 6 is a simplified block diagram of a control module portion of the untethered stylet of FIG. 4, together with associated components of the console of FIG. 1;

[0014] FIGS. 7A and 7B are various views of a datum module according to one embodiment;

[0015] FIG. 8 is a simplified block diagram of a control module portion of the datum module of FIGS. 7A and 7B, together with associated components of the console of FIG. 1;

[0016] FIG. 9 is a simplified diagram showing various components employed in synchronizing a pulse signal frequency between a wireless stylet and a console of the system of FIG. 1;

[0017] FIG. 10 is a simplified view of a patient and a catheter being inserted therein with assistance of the integrated system of FIG. 1;

[0018] FIG. 11 is a screenshot as depicted on a display of the integrated system of FIG. 1, indicating a position of a distal end of the stylet of FIG. 4 during catheter tip placement procedures;

[0019] FIG. 12 is a simplified view of a patient and a catheter being inserted therein with assistance of the integrated system of FIG. 1;

[0020] FIG. 13 is a screenshot as depicted on a display of the integrated system of FIG. 1, indicating a position of a distal end of multiple stylets such as that shown in FIG. 4 during catheter tip placement procedures;

[0021] FIG. 14 is a side view of a stylet including multiple radiating elements in accordance with one embodiment;

[0022] FIG. 15 is a partial cross sectional view of a vessel including a plurality of stylets positioned therein in accordance with one embodiment;

[0023] FIG. 16 is a perspective view of a flexible sensor unit in accordance with one embodiment;

[0024] FIG. 17 is a simplified view of the sensor unit of FIG. 16;

[0025] FIGS. 18A and 18B depict various views of a needle assembly according to one embodiment;

[0026] FIG. 19 is a perspective view of a distal portion of the needle assembly of FIGS. 18A and 18B;

[0027] FIG. 20 shows the needle assembly of FIGS. 18A and 18B in use;

[0028] FIG. 21 is a perspective view of a breast marker in accordance with one embodiment; and

[0029] FIG. 22 is a partial cross-sectional view showing an imaging operation for breast markers such as those shown in FIG. 21.

DETAILED DESCRIPTION OF SELECTED EMBODIMENTS

[0030] Reference will now be made to figures wherein like structures will be provided with like reference designations. It is understood that the drawings are diagrammatic and schematic representations of exemplary embodiments of the present invention, and are neither limiting nor necessarily drawn to scale.

[0031] For clarity it is to be understood that the word “proximal” refers to a direction relatively closer to a clinician using the device to be described herein, while the word “distal” refers to a direction relatively further from the clinician. For example, the end of a catheter placed within the body of a patient is considered a distal end of the catheter, while the catheter end remaining outside the body is a proximal end of the catheter. Also, the words “including,” “has,” and “having,” as used herein, including the claims, shall have the same meaning as the word “comprising.”

[0032] Embodiments of the present invention are generally directed to a system for tracking the position of one or more medical devices for at least partial insertion into and/or advancement within the body of a patient. The system may also be used to locate one or medical devices at a later time after placement thereof. Examples of medical devices that can be tracked and positioned using the present system include catheters, breast markers, needles, etc.

[0033] The present system includes the use of multiple radiating elements that can be simultaneously detected by a sensor unit of the system, wherein at least one of the radiating elements is included with the medical device, in one embodiment. Another of the radiating elements may be placed at a predetermined point on the skin of the patient to serve as a landmark to help determine the location of the medical device with respect to the landmark. Detection of the radiating elements by the sensor unit enables the relative positions of the radiating elements to be ascertained and depicted on a display, including two and/or three-dimensional depictions, so as to in turn enable a clinician to observe the relative position of the medical device(s) and landmarks. This assists the clinician in positioning the medical device in a desired position within the patient body.

[0034] In one embodiment, for example, one of the radiating elements includes an electromagnetic coil that is included with a stylet. The stylet is removably received within a lumen of a catheter that is introduced and advanced through the vasculature of the patient. Another radiating element, such as a second electromagnetic coil, is placed atop the chest of the patient to serve as a reference point, or landmark. A sensor unit can be placed in proximity to the patient, such as at the bedside of the patient, so as to enable both electromagnetic coils to be detected during insertion and advancement of the catheter. Detection and tracking of the two electromagnetic coils can enable the clinician to determine if the catheter is being advanced along a desired route or if the catheter has been malpositioned or has encountered an obstacle. In one embodiment, data received from tracking the electromagnetic coils can be used to map the path of catheter advancement, which map can be depicted on a display for use by the clinician, or stored for future reference. Note that more than two coils can be included and used by the system to provide additional data points for accurately detecting the position and advancement

of the medical device. Also, more than one medical device can be tracked by the system, in one embodiment.

[0035] FIGS. 1 and 2 depict various details of a medical device tracking system (“system” or “tracking system”), generally designated at 10, which serves as one example environment wherein embodiments of the present disclosure can be practiced. The system 10 is employed to assist a clinician in the placement of a catheter or other medical device(s) within the body of a patient, such as within a vein or other vessel. In one embodiment, the medical device includes a catheter and the intended destination of the catheter within a vein of the patient body is such that the distal tip of the catheter is disposed in the lower $\frac{1}{3}^{rd}$ portion of the superior vena cava (“SVC”). As such, the system assists the clinician by tracking and visualizing advancement of the catheter or other medical device(s) as it advances toward its intended destination within the patient body.

[0036] As mentioned, FIGS. 1 and 2 depict various components of the system 10 in accordance with one example embodiment. As shown, the system 10 generally includes a console 20, display 30, and sensor unit (“sensor”) 50, each of which is described in further detail below.

[0037] FIG. 2 shows the general relation of these components to a patient 70 during a procedure to place a catheter 72 into the patient vasculature through a skin insertion site 73. FIG. 2 shows that the catheter 72 generally includes a proximal portion 74 that remains exterior to the patient and a distal portion 76 that resides within the patient vasculature after placement is complete. In the present embodiment, the system 10 is employed to ultimately position a distal tip 76A of the catheter 72 in a desired position within the patient vasculature. In one embodiment, the desired position for the catheter distal tip 76A is proximate the patient’s heart, such as in the lower one-third ($\frac{1}{3}^{rd}$) portion of the Superior Vena Cava (“SVC”). Of course, the system 10 can be employed to place the catheter distal tip in other locations. The catheter proximal portion 74 further includes a bifurcation hub 74A that provides fluid communication between the one or more lumens of the catheter 72, one or more extension tubes 74B extending proximally from the hub, and corresponding connectors 74C for enabling connection to the catheter 72.

[0038] FIG. 1 shows that a processor 22, including non-volatile memory such as EEPROM for instance, is included in the console 20 for controlling system function during operation of the system 10, thus acting as a control processor. A digital controller/analog interface 24 is also included with the console 20 and is in communication with both the processor 22 and other system components to govern interfacing between the sensor 50, and other system components.

[0039] The system 10 further includes ports 52 for connection with the sensor 50 and optional components 54 including a printer, storage media, keyboard, etc. The ports in one embodiment are USB ports, though other port types or a combination of port types can be used for this and the other interfaces connections described herein. A power connection 56 is included with the console 20 to enable operable connection to an external power supply 58. An internal battery 60 can also be employed, either with or exclusive of an external power supply. Power management circuitry 59 is included with the digital controller/analog interface 24 of the console to regulate power use and distribution.

[0040] The display 30 in the present embodiment is integrated into the console 20 and is used to display information to the clinician during the catheter placement procedure. In

another embodiment, the display may be separate from the console. In one embodiment, a console button interface 32 can be used to control depiction of images on the display 30 by the clinician to assist in the placement procedure, as will be seen. In one embodiment, the display 30 is an LCD device. Also, the buttons included on the console button interface 32 can be configured in a variety of ways, including the use of user input controls in addition to buttons, such as slide switches, toggle switches, electronic or touch-sensitive pads, etc.

[0041] As mentioned, the system 10 is configured to detect and track a plurality of radiating elements associated with one or more medical devices for placement within the body of the patient. Thus, the system 10 enables the clinician to quickly locate and confirm the position and/or orientation of one or more medical devices, such as a peripherally-inserted central catheter (“PICC”), central venous catheter (“CVC”), or other suitable catheter or medical device, during initial placement into and advancement through the vasculature or other body portion of the patient 70.

[0042] Briefly, the system 10 is configured to detect electromagnetic radiation, such as an electromagnetic field, generated by a radiating element included with the medical device(s). In the embodiment shown in FIGS. 1 and 2, for instance, a radiating element (to be described further below) is included proximate the distal tip 76A of the catheter 72. The radiating element, together with one or more other radiating elements, is detectable by the sensor unit 50 placed in proximity to the patient, thus enabling the display 30 to graphically depict the detected location of the radiating element, and thus the distal tip 76A of the catheter 72. This assists the clinician to ascertain the general location and orientation of the catheter tip within the patient body. It is appreciated that the teachings of one or more of the following U.S. patents may be employed in one embodiment in the above-described tracking: U.S. Pat. Nos. 5,775,322; 5,879,297; 6,129,668; 6,216,028; and 6,263,230. The contents of the afore-mentioned U.S. patents are incorporated herein by reference in their entirety. Note that the system 10 in one embodiment can display the direction in which the catheter distal tip 76A is pointing, thus further assisting accurate catheter placement. The system 10 in one embodiment can further assist the clinician in determining when a malposition of the catheter tip has occurred, such as in the case where the catheter distal tip 76A has deviated from a desired venous path into another vein.

[0043] In accordance with one embodiment, the above-described radiating element is included with a stylet that is removably inserted into the catheter such that the radiating element is co-terminal with the distal end of the catheter. Further, the stylet including the radiating element is physically untethered to a console or other component of the system 10. Thus, the stylet itself includes all necessary componentry for producing the electromagnetic field, such as an electrical pulse signal, for use by the system. The stylet in one embodiment further includes functionality to synchronize its pulsing activities with the console 20 of the system 10 such that the system can accurately track advancement of the stylet and its corresponding catheter through the patient vasculature. In another embodiment, the stylet including the radiating element can be tethered to the sensor unit or other component of the system 10 in such a way as to enable the passage of driving signals from the sensor unit 50 or system console 20 to the radiating element

through a sterile barrier interposed between the catheter/stylet and sensor unit or console without compromising the barrier itself or the sterile field it helps establish.

[0044] As mentioned, the system 10 in the present embodiment utilizes a stylet to enable the distal end of the catheter 72 to be tracked during its advancement through the vasculature. FIGS. 4 and 5 give an example of a detached configuration of such a stylet 130, configured in accordance with one embodiment. In particular, the stylet 130 in FIGS. 4 and 5 is physically detached, or untethered, from other components of the system 10. The stylet 130 includes a proximal end 130A and a distal end 130B. A control module 102 for the stylet 130, also referred to herein as a “fob,” is included at the stylet proximal end 130A, with an elongate portion 134 extending distally therefrom.

[0045] FIG. 5 gives further details regarding a distal portion of the stylet elongate portion 134 proximate the stylet distal end 130B. As shown and as mentioned above, the stylet 130 includes a first radiating element 150, here embodied as an electromagnetic (“EM”) coil 106, which is included proximate the stylet distal end 130B and is operably connected to leads 106A. The EM coil 106 and leads 106A can include insulated copper wire in the present embodiment. The leads 106A are in turn operably connected to corresponding circuitry located in the stylet control module 132 configured to produce an electric pulse signal so as to enable the EM coil 106 to be electrically pulsed during operation and produce an electromagnetic field having a predetermined frequency or pattern that is detectable by one or more sensors included in the sensor unit 50 during transit of the catheter 72 through the vasculature when the EM coil 106 is within the detectable range of the sensor unit.

[0046] Note that the EM coil 106 described herein is but one example of a radiating element, or a component capable of producing electromagnetic radiation, such as an electromagnetic field for detection by the sensor unit. Indeed, other devices and assembly designs can be utilized here to produce the same or similar functionality. For instance, non-limiting examples of other stylet configurations can be found in U.S. patent application Ser. No. 12/545,762, filed Aug. 21, 2009, and entitled “Catheter Assembly Including ECG Sensor and Magnetic Assemblies,” which is incorporated herein by reference in its entirety. In the embodiments herein, more than one radiating element is included for use with the system 10, as will be described further below. In another embodiment, radiating elements of different types (e.g., ultrasonic and electromagnetic) can be included together.

[0047] The EM coil 106 and leads 106A are disposed within tubing 108 that extends at least a portion of the length of the stylet elongate portion 134. In one embodiment, the tubing includes polyamide. The EM coil 106 and leads 106A can be protected in other ways as well. A core wire 110 is also included within the tubing 108 in one embodiment to offer stiffness and/or directional torqueability to the stylet elongate portion 134. The core wire 110 in one embodiment includes nitinol and can extend to the distal end 130B of the stylet 100 or terminate proximal thereto. In the present embodiment, at least the portion of the core wire 110 that extends within the EM coil 106 includes a ferromagnetic and/or magnetically permeable material, such as iron, iron-containing steel, or other suitable material. Note that the EM coil can be configured in other ways as well; as such, the disclosure herein regarding this and the other radiating elements is not intended to be limiting.

[0048] In accordance with the present embodiment, the stylet 130 is untethered, or physically unconnected, with respect to the console 20 of the system 10. As such, the electric pulsing of the EM coil 106 to produce the predetermined electromagnetic field is driven by suitable componentry included in the fob, or stylet control module 132, as opposed to pulse driving by the console or other system component to which the stylet would be physically connected. FIG. 6 shows such componentry according to one example embodiment. The control module 132 includes a housing 132A in which a printed circuit board (“PCB”) 232 or other suitable platform is housed. Pulse circuitry 234 is disposed on the PCB 232 and includes a timer circuit 236 configured to provide electrical pulses to the EM coil assembly 106 via the leads 106A (FIG. 5). It is noted that in one embodiment the electromagnetic field can be pulsed so as to produce a predetermined pattern, if desired.

[0049] A connector 230A is included on the control module housing 132A and configured to removably and operably connect with a corresponding connector 230B included on a proximal end of the stylet elongate portion 134. In this way, operable connection between the timer circuit 236 and the EM coil 106 via the leads 106A is achieved in the present embodiment. Note that other connective schemes between the pulse circuitry 234 and the EM coil 106 can be used. In another embodiment, the stylet elongate portion is permanently connected to the stylet control module.

[0050] A power supply 240 is included with the stylet control module 132 to provide power necessary for control module functions, including operation of the pulse circuitry 234 and driving of the electric pulsing performed by the timer circuit 236. In one embodiment, the stylet 130 is a disposable, one-time use component and as such the power supply 240 is also disposable, such as a button-cell battery. In other embodiments, the power supply can be a rechargeable battery, a long-life power supply, or can be configured to be replaceable as may be appreciated by one skilled in the art. In one embodiment, the stylet control module 132 includes an on/off switch for controlling operation of the control module components.

[0051] As mentioned, the timer circuit 236 drives the EM coil 106 by sending electrical pulses at a predetermined frequency to the EM coil via the leads 106A to which the timer circuit is operably connected. Receipt of the pulses causes the EM coil 106 to emit an electromagnetic field having the predetermined frequency that is detectable by the sensor unit 50 of the system 10, thus assisting guidance of the catheter 72 (FIG. 2) as described herein.

[0052] In one embodiment, the electric pulse signal of the timer circuit 236 is synchronized with the console 20, or other system component (such as the sensor unit 50), to enable the system 10 to identify the frequency of the field produced by the EM coil 106 as a result of the pulsing. This enables the console 20 to identify the proper field relating to the EM coil 106 of the stylet 130 and the sensor unit 50 to accurately track progress of the stylet during intravascular advancement of the catheter 72. The particular frequency/frequencies employed for the pulse signal in one embodiment comply with applicable laws and regulations, including regulations promulgated by the Federal Communications Commission (“FCC”). In one implementation a frequency of about 1 MHz may be used, for example.

[0053] In the present embodiment, synchronization of the pulse signal frequency produced by the timer circuit 236 with the console 20 is achieved by a transmitter 238 included with the stylet control module 132, as seen in FIGS. 4 and 6. The transmitter 238 is operably connected to and receives data from the timer circuit 236 relating to the frequency of its pulse signal being sent to the EM coil 106. The transmitter 238 transmits the data to a receiver 242 included on the console 20. Receiving the data by the receiver 242, the console 20 can then identify the electromagnetic field produced by the EM coil 106 when detected by the sensor unit 50 and thus track intravascular advancement of the catheter 72.

[0054] In one implementation, the data transmitted by the transmitter 238 include a message detailing the pulsing frequency of the pulse signal produced by the timer circuit 236. In another implementation, the data are merely a replication of the pulse signal itself that, when received by the console 20, enable the console to determine the frequency. The console processor 22 (FIG. 1) or other suitable console circuitry can be employed to perform this determination functionality. Of course, the data can take any one of a variety of formats and configurations to enable information relating to the pulse signal to be received by the console 20 or other suitable component of the system. In certain embodiments, the console 20, the sensor unit 50, or other suitable component of the system 10 can include the necessary circuitry to synchronize with the signal produced by the stylet 130, as described herein.

[0055] The transmitter 238 can transmit, and the receiver 242 receive, the above-referenced data in any number of ways, but in one implementation the transmitter wirelessly transmits via infrared (“IR”) or radiofrequency (“RF”) radiation wavelengths for receipt by the receiver. As such, for example, the transmitter 238 and receiver 242 can be configured as an IR LED/detector pair in the first case, or as an antenna pair in the second case. Note that other types of transmitter/receiver configurations can be included to perform the intended functionality described herein. Other forms of electromagnetic radiation can be employed to transmit data, including visible light in one embodiment. Also note that the transmitter 238 and the receiver 242 can each serve as transmitters/receivers in this and other embodiments herein.

[0056] In one embodiment, the timer circuit of the untethered stylet control module is configured to be adjustable such that the pulse frequency can be selected from a plurality of predetermined frequency options. Such functionality may assist in the case where interference exists on one or more of the predetermined frequencies, where different stylets are used successively by the same system (as discussed below), or where multiple systems are used simultaneously in close proximity to one another. In such a configuration, a selector switch may be included on the control module housing 132A, the console 20, and/or other suitable system component. The above or other suitable synchronization scheme can be used to coordinate the selected pulse frequency to be transmitted and received between the stylet control module and the console.

[0057] In another implementation, the stylet control module/console automatically switches to one of a plurality of possible pulse frequencies for use in driving the EM coil. In this latter implementation, the console can be configured to successively scan the plurality of possible frequencies and

perform frequency identification functions, including phase locking (e.g., via a phase locking circuit), to identify the frequency on which the stylet control module timer circuit is producing the electrical pulse signal, as well as the frequencies of other EM coils of the system, thus enabling synchronization of the console therewith.

[0058] FIG. 9 shows an example of the above automatic synchronization implementation, according to one embodiment. As shown, a transmitter such as an antenna 239 is included with the stylet control module 132 and is configured to emit radiofrequency (“RF”) or other suitable signals. A receiver such as an antenna 243 is included with the console 20 of the system 10 to receive signals emitted by the stylet control module antenna 239. The console 20 further includes various components for processing signals received by the antenna 243, including a mixer 363, an oscillator 365, a low pass filter 364, an analog-to-digital converter (“ADC”) 367, and a digital signal processor (“DSP”) 368.

[0059] During operation of the system 10, the stylet antenna 239 of the stylet control module 132 emits an RF or other suitable signal (e.g., infrared (“IR”)) that provides data relating to the frequency of the pulse signal. The RF signal is received by the console antenna 242. The mixer 363 combines the signal received by the antenna 242 with a predetermined signal generated by the oscillator 365, which combined signal is then filtered through the low pass filter 364 to remove any extraneous signals. The filtered and combined signal is passed through the ADC 367, then analyzed by the DSP 368 to determine whether the two signals forming the combined signal match. If so, phase shifting of the signals will be performed by the DSP and/or oscillator 365 to lock the signals in phase.

[0060] If the signals do not match, the above process is repeated with a new signal having a different frequency being produced by the oscillator 365. The above process is iteratively repeated until the signal from the oscillator 365 matches in frequency the signal emitted by the stylet control module antenna 239 and subsequently received by the console antenna 242. Thus, the oscillator 365 in one embodiment is capable of cycling through a plurality of pre-set signal frequencies in attempting to match the emitted signal of the stylet control module antenna 239. In another embodiment, the oscillator can cycle through a range of frequencies in attempting to match the emitted signal. As noted before, once the proper signal frequency is determined by the console 20, phase shifting as needed can be conducted to complete synchronization between the EM coil 106 of the stylet 130 and the console 20, thus enabling the console to track the EM coil.

[0061] It is understood that the above is merely one example of synchronizing the pulse signal produced by the stylet coil assembly with the console and that other implementations can be employed to link the frequency between the stylet coil assembly and console or other component of the system.

[0062] In another embodiment, it is appreciated that the transmitter/receiver configuration can be reversed such that the transmitter is included with the console and directs information regarding the frequency of the pulse signal to the stylet control module, which receives the information via a receiver included therein. In yet another embodiment, both the stylet and the console are manufactured to operate with a pre-set pulse signal frequency, requiring no subsequent synchronization therebetween. These and other possible

configurations are therefore contemplated. Generally, it should be understood that the pulse circuitry and timer circuit of the stylet control module, together with the processor of the console 20, can be configured in one or more of a variety of ways to achieve above-described functionality. For instance, the processor 22 of the console 20 can be included in the sensor unit 50 (FIGS. 1, 3) such that synchronization operations on behalf of the system 10 are performed by the sensor unit. Or, in another embodiment the stylet functionality is incorporated into the catheter itself and no removable stylet is employed.

[0063] As mentioned, the system 10 in the present embodiment utilizes multiple radiating elements to assist in tracking a medical device(s) as it is inserted into a patient body and/or to locate the medical device post-insertion. As discussed above the radiating element 150, implemented as the EM coil 106 included in the catheter stylet 130, serves as the first radiating element to provide an electromagnetic field that can be tracked by the system 10. FIGS. 7A and 7B show a datum module 158 that houses a second radiating element 160, implemented in the present embodiment as an electromagnetic (“EM”) coil 276 configured to an electromagnetic field detectable by the sensor unit 50 of the system 10, similar to the detection of the EM coil 106 of the stylet 130, and depicted graphically on the display 30 of the system 10. In the present embodiment, the datum module 158 is employed to serve as a reference point or external landmark (e.g., external marker) to assist in determining the location of the EM coil 106 of the stylet 130 as the catheter 72 is advanced through the vasculature of the patient. As such, in the present embodiment the datum module 158 can be placed on a skin surface of the patient 70 and, when detected by the sensor unit 50 can help determine the location of the EM coil 106 of the catheter stylet by depicting on the display 30 a positional relationship between the EM coil 106 and the EM coil 276 of the datum module 158, which itself is located at a landmark on the patient skin surface.

[0064] FIGS. 7A and 7B depict various details of the datum module 158, in accordance with the present embodiment. As shown, the datum module 158 includes an outer housing 250 that houses various components such as those shown in simplified form in FIG. 7B, including a PCB 262 and a power source 270, such as a battery. Also shown in the housing 250 is the second radiating element 160 referred to above, here implemented as the EM coil 276, though it is appreciated that type of other radiating elements can also be employed here, as is the case with the other radiating elements referred to herein. The EM coil 276 is operably connected to the power source 270 via insulated copper wire leads or the like to enable the EM coil to emit electric pulse signals during system operation. As is the case with the stylet 130 and its EM coil 106, the datum module 158 and its EM coil 276 are physically detached, or untethered, from other components of the system 10. The datum module housing 250 includes various other components for controlling operation of the datum module 158 and its interaction with the system 10 in tracking medical devices.

[0065] The datum module 158 is configured to produce an electric pulse signal via its EM coil 276 such that the resultant electromagnetic field having a predetermined frequency or pattern is detectable by the sensors included in the sensor unit 50. As mentioned, detection of the datum module 158 by the sensor unit 50 enables it to serve as a reference

point/landmark during transit of the catheter 72 and its corresponding EM coil-equipped stylet 130 through the vasculature.

[0066] FIG. 8 depicts the various components included in the datum module 158 to enable it to operate as an untethered component as described herein in accordance with the present embodiment, namely, the electric pulsing of the EM coil 276 to produce the predetermined electromagnetic field. The components include a printed circuit board (“PCB”) 262 or other suitable platform, pulse circuitry 264 disposed on the PCB, and a timer circuit 266 configured to provide electrical pulses to the EM coil 276. It is noted that in one embodiment the electromagnetic field can be pulsed so as to produce a predetermined pattern, if desired.

[0067] A power supply 270 is included with the stylet control module 132 to provide power necessary for control module functions, including operation of the pulse circuitry 264 and driving of the electric pulsing performed by the timer circuit 266. In one embodiment, the datum module 158 is a disposable, one-time use component and as such the power supply 270 is also disposable, such as a button-cell battery. In other embodiments, the power supply can be a rechargeable battery, a long-life power supply, or can be configured to be replaceable as may be appreciated by one skilled in the art. In one embodiment, the datum module 158 includes an on/off switch for controlling its operation.

[0068] As with the EM coil 106 of the stylet 130, the timer circuit 266 of the datum module 158 drives the EM coil 276 by sending electrical pulses at a predetermined frequency to the EM coil to which the timer circuit is operably connected. Receipt of the pulses causes the EM coil 276 to emit an electromagnetic field having the predetermined frequency that is detectable by the sensor unit 50 of the system 10, as described herein.

[0069] In one embodiment, the electric pulse signal of the timer circuit 266 is synchronized with the console 20, or other system component (such as the sensor unit 50), to enable the system 10 to identify the frequency of the field produced by the datum module EM coil 276 as a result of the pulsing. This enables the console 20 to identify the proper field relating to the EM coil 276 of the datum module 158 and to differentiate it from the electromagnetic fields of other radiating elements of the system 10, such as the EM coil 106 of the stylet 130, discussed above. This in turn enables the sensor unit 50 and system 10 to accurately track progress of the stylet 130 during intravascular advancement of the catheter 72 as well as track the position of the datum module 158 as a reference point to assist in localizing the position of the stylet (or other medical device) with respect to the datum module. As before, the particular frequency/frequencies employed for the pulse signal in one embodiment comply with applicable laws and regulations, including regulations promulgated by the Federal Communications Commission (“FCC”).

[0070] In the present embodiment, synchronization of the pulse signal frequency produced by the timer circuit 266 with the console 20 is achieved by a transmitter 268 included with the datum module 158, as seen in FIG. 8. The transmitter 268 is operably connected to and receives data from the timer circuit 266 relating to the frequency of its pulse signal being sent to the EM coil 276. The transmitter 268 transmits the data to the receiver 242 included on the console 20. Receiving the data by the receiver 242, the console 20 can then identify the electromagnetic field produced by the

datum module EM coil 276 when detected by the sensor unit 50, differentiate it from the signals of any other EM coils of the system 10, and thus track both the intravascular advancement of the catheter 72 and the position of the datum module 158. The configuration and operation of the transmitter 268 and the receiver 242 is similar to that described in connection with the transmitter 238 and receiver 242 with respect to the stylet control module 132, further above. Indeed, operation of the components of the datum module 158 shown in FIG. 8 is similar to that described in connection with the components of the stylet control module 132 of FIG. 6. Further, the discussion relating to an automatic synchronization of pulse signal frequency between the stylet control module 132 and the console 20 detailed above in connection with FIG. 9 also corresponds to synchronization of the datum module 158 with the console, in the present embodiment, with the antenna 239 representative of an antenna included with the datum module 158. In another embodiment, it is appreciated that the pulse signals of the EM coils of the system can be multiplexed together (such as via time-based multiplexing), instead of differing in frequency/wavelength. As such, this and other modes for distinguishing the pulse signals of the various radiating elements are appreciated.

[0071] As seen in FIGS. 3A and 3B and as mentioned above, the system 10 includes a sensor unit 50 for detecting the position and movement of the first and second radiating element, i.e., the EM coil 106 of the stylet 130 and the EM coil 276 of datum module 158 in the present embodiment, during a procedure to place or locate a medical device within the body of a patient. The sensor unit 50 includes a sensor array 190 comprising a plurality of sensors 192 embedded within the housing of the sensor unit. The sensors 192 are configured to detect a magnetic field (a segment of its electromagnetic field) produced by the EM coils 106, 276, as well as any other radiating elements that are part of the system 10, such as in the case of multiple EM coils used to track a plurality of medical devices. Though they are shown in FIGS. 3A and 3B as included with the sensor unit 50 having a certain size and shape, the sensors 192 of the sensor array 190 can be included in a sensor unit having a different shape, size, or other configuration. In the present embodiment, the sensors 192 are disposed in a planar configuration below a top face of the sensor unit 50, though it is appreciated that the sensors can be arranged in other configurations, such as in an arched or semi-circular arrangement.

[0072] In the present embodiment, each of the sensors 192 includes three orthogonal sensor coils for enabling detection of a magnetic field in three spatial dimensions. Such three dimensional (“3-D”) magnetic sensors can be purchased, for example, from Honeywell Sensing and Control of Morris-town, N.J. Further, the sensors 192 of the present embodiment are configured as Hall-effect sensors, though other types of magnetic sensors could be employed. Further, instead of 3-D sensors, a plurality of one dimensional magnetic sensors can be included and arranged as desired to achieve 1-, 2-, or 3-D detection capability.

[0073] In the present embodiment, six sensors 1192 are shown included in the sensor array 190 so as to enable detection of the EM coils 106, 276 in not only the three spatial dimensions (i.e., X, Y, Z coordinate space), but also the pitch and yaw orientation of the EM coil itself. Note that in one embodiment, orthogonal sensing components of two

or more of the sensors **192** enable the pitch and yaw attitude of the EM coil **106** for instance, and thus the medical device, to be determined.

[0074] In other embodiments, fewer or more sensors can be employed in the sensor array. More generally, it is appreciated that the number, size, type, and placement of the sensors of the sensor array can vary from what is explicitly shown here. In one embodiment, at least three sensors are employed.

[0075] The placement of the sensor unit **50** can be varied according to type of medical device placement scenario, the logistics of the insertion procedure, etc. For instance, FIG. **2** shows the sensor unit **50** positioned at a side of the patient **70** where it can detect the electromagnetic fields produced by the EM coils **106**, **276**. Such a placement may be used to position the sensor unit **50** at the bedside of the patient **70** in a hospital or clinic setting, for instance. However, multiple other placements of the sensor unit **50** are possible, including on the chest or other skin surface of the patient, adjacent a body part of interest, etc. Note further that the size, shape, and other configuration of the sensor unit can vary from what is explicitly shown and described herein.

[0076] Reference is made to FIGS. **2** and **10**, which depict disposal of the untethered stylet **130** substantially within a lumen in the catheter **72** such that the proximal portion thereof, including the control module **132**, extends proximally beyond the catheter lumen, the hub **74A** and a selected one of the extension legs **74B**. So disposed within a lumen of the catheter, the first radiating element **150**, implemented as the EM coil **106** and located proximate the distal end **130B** of the stylet **130**, is substantially co-terminal with the distal catheter end **76A** such that detection by the system **10** of the stylet EM coil correspondingly indicates the location of the catheter distal end. Further, the datum module **158**, including the second radiating element **160** implemented as the EM coil **276**, is also shown sitting atop a central portion of the chest of the patient **70**, though it is appreciated that this is just one of a variety of possible placement locations for the datum module, both on or off the patient body, to serve as a reference marker. It is appreciated that both EM coils **106**, **276** are powered and operating during the procedure so as to produce their respective electromagnetic fields for detection.

[0077] Note that the electromagnetic field of each EM coil includes a unique characteristic unique within the system **10** so as to be distinguishable and separately trackable by the system. This is accomplished in one embodiment by each EM coil producing an electromagnetic field that differs in frequency and/or amplitude from the other EM coil(s) of the system. Such differentiation of electromagnetic fields can be configured as a permanent configuration for each EM coil at the time of manufacture/setup of the system **10**, in one embodiment. In another embodiment, the system can actively assign and/or change the EM coil configurations using the teachings discussed above in connection with FIG. **9**. Of course and more generally, other modes of producing unique types of electromagnetic radiation from each radiating element are also contemplated herein. In one embodiment, the electromagnetic fields of the EM coils are time multiplexed together or treated to other multiplexing operations. Thus, this is another example of a unique characteristic the radiating elements can possess in order to be differentiated by the system.

[0078] The sensor unit **50** is employed by the system **10** during operation to detect the electromagnetic field produced by the EM coil **106** of the stylet **130**. As mentioned above, the sensor unit **50** is placed in the present embodiment to the side of the patient **70** during catheter insertion, one of a plurality of possible locations for the sensor unit to reside, to enable the field of the EM coil **106**, disposed in the catheter **72** as described above, to be detected during catheter transit through the patient vasculature. Again, as the EM coil **106** is substantially co-terminal with the distal end **76A** of the catheter **72** (FIG. **2**), detection by the sensor unit **50** of the field produced by the EM coil **106** provides information to the clinician as to the position and orientation of the catheter distal end **76A** during its transit.

[0079] FIGS. **2** and **10** further depict the datum module **158** positioned on a central chest portion of the patient **70**. So disposed, the second radiating element **160**, implemented here as the EM coil **276**, is prepared for detection by the sensor unit **50** and to serve as a reference marker.

[0080] In greater detail, the sensor unit **50** is operably connected to the console **20** of the system **10** via the console cable **140** and one or more of the ports **52**, as shown in FIGS. **1** and **2**. Note that other connection schemes between the sensor unit **50** and the system console **20** can also be used without limitation. As just described, the EM coil **106** is employed in the stylet **130** to enable the position of the catheter distal end **76A** (FIG. **2**) to be observable relative to the sensor unit **50** placed to the side of the patient. Detection by the sensor unit **50** of the stylet EM coil **106** is graphically displayed on the display **30** of the console **20** during system operation, represented in FIG. **11** (discussed below), for example. In this way, a clinician placing the catheter **72** is able to generally determine the location of the catheter distal end **76A** within the patient vasculature relative to the sensor unit **50** and detect when catheter malposition, such as advancement of the catheter along an undesired vein, is occurring.

[0081] Correspondingly, the EM coil **276** of the datum module **158** is employed to serve as a reference point for assisting location of the EM coil **106** associated with the catheter (or other medical device). Detection by the sensor unit **50** of the datum module EM coil **276** can be graphically displayed on the display **30** of the console **20** during system operation. This is shown in FIG. **11**, which depicts a screenshot **380** of the display **30** during operation of the system **10**. As shown, the screenshot **380** depicts a simplified stock outline body image **382**. Also shown is an icon **390** that represents the EM coil **106** disposed at the distal end of the stylet **130** and disposed in one of the lumens of the catheter **72** as it is being inserted through a vein of the patient **70** (FIG. **2**). The icon **390** shows the position of the EM coil **106** as detected by the sensor unit **50** of the system **10**. Also shown in broken line trailing the icon **390** is the previous path of the EM coil **106** as it traversed through the vein.

[0082] FIG. **11** further shows an icon **394** that represents the EM coil **276** of the datum module **158** that is positioned atop a central chest portion of the patient **70**, as shown in FIG. **2**. The icon **394** shows the position of the EM coil **106** as detected by the sensor unit **50**. As the datum module **158** is kept relatively stationary during the catheter insertion procedure, the icon **394** stays relatively in place as depicted on the screenshot **380** of the display **30**. FIG. **10** shows that the system **10**, by virtue of the ability of the sensors **192** of

the sensor unit **50** to detect the relative positions of both EM coils **106** and **276**, can determine (among other positional relationships) a distance z between the EM coil **106** and the EM coil **276** in real-time, thus determining a distance in the z -direction existing between the distal **76A** of the catheter **72** disposed within the vein and the skin surface of the central chest of the patient **70** where the datum module **158** is disposed. In this way, the datum module **158**, with its EM coil **276**, serves as a reference marker to further assist in determining the location of the catheter **72** (or other medical device) with respect to a landmark, such as the chest of the patient **70**.

[0083] Note that the icon **390** shown in FIG. **11** includes a central dot surrounded by a varying number of concentric circles, wherein more circles indicate a relatively deeper depth of the EM coil **106** as detected by the sensor unit **50**. The icon **394** representing the datum module **158** includes a dot surrounded by a diamond. Of course, it is appreciated that a variety of other shapes and configurations can be employed for the icons **390**, **394**. Note further that various depiction modes can be depicted by the display in one embodiment, include two-dimensional and three-dimensional representations. Also, it is appreciated that the tracking of one or more radiating elements as described herein can enable a clinician in one embodiment to map a portion of a vasculature or other structure of the patient, as well as identify medical device mal-positions, obstacles/obstructions to advancing the medical device, arterial vs. venous catheter placements, IVC vs. SVC device placement, innominate vein/artery placement, etc. The system may be used in one embodiment for delicate medical device placement, including neo-natal placements, placements where the patient is wearing a neck brace or other obstruction that would otherwise make medical device placement difficult, etc.

[0084] It should be appreciated that in one embodiment the positions of the radiating element and the sensor can be reversed such that a remotely powered sensor is included with the stylet and with the datum module for detecting a field produced by a radiating element positioned external to the body of the patient.

[0085] FIG. **12** depicts a system configuration according to another embodiment wherein the catheter **72**, including the EM coil-equipped stylet **130**, is inserted into a femoral vein at an insertion site **73** on an upper leg of the patient **70**. The datum module **158** including its EM coil **276** is positioned on a lower torso portion of the patient **70**. The sensor unit **50** is positioned to the side of the patient **70**. The embodiment of FIG. **12** depicts one of many possible implementations for the system **10**, including insertion of a catheter through a lower portion of the patient body, for instance. As such, it should be appreciated that a variety of different catheters can be placed by the system **10** as described herein, including urinary, ablation, arterial, PICC, CVC, etc.

[0086] FIG. **13** depicts a system configuration according to another embodiment, showing the screenshot **380** with the stock body image **382** superimposed thereon. Two icons **390** are shown, representing EM coils included on stylets that are disposed in two separate catheters that are being inserted into different locations within the body of the patient. In addition, two icons **394** are shown, representing two EM coil-equipped datum modules **158** that are disposed at different locations on the chest of the patient, such as bordering

the perimeter of the heart, for instance. Thus, this embodiment demonstrates the ability of the system **10** to track more than two radiating elements, such as EM coils, in order to assist in the placement of two or more medical devices simultaneously. It should be appreciated that a variety of different combinations of radiating elements associated with datum modules and medical devices may be employed by the system **10**. For instance, in one embodiment, four EM coils or other type of suitable radiating elements can each be included with three datum modules and one medical device, for instance, in order to track the medical device to an intended destination within the patient body. These and other configurations are therefore contemplated.

[0087] Note that, in one embodiment, the control module housing **132A** of the stylet **130** can serve as a handle to assist in manipulating the catheter **72** and/or stylet during intravascular advancement. Note also that the untethered nature of the stylet **130** and the datum module **158** enable their use in a sterile setting without need to pierce a sterile barrier established around the patient during the medical device insertion procedure with wires or other connection modes. However, in another embodiment, it is appreciated that the EM coils can be operated via wire attachment if desired.

[0088] It should be appreciated herein that “stylet” as used herein can include any one of a variety of devices configured for removable placement within a lumen of the catheter to assist in placing a distal end of the catheter in a desired location within the patient’s vasculature. In one embodiment, the stylet includes a guidewire. As such, it is appreciated that stylets of other forms and configurations can also be acceptably used, in accordance with the present disclosure.

[0089] FIG. **14** depicts a system configuration according to another embodiment, wherein the stylet **130** includes dual radiating elements, i.e., a first radiating element **150** disposed proximate the distal end of the stylet and an additional radiating element **162** disposed proximal to the first radiating element. Thus, it is appreciated that the distribution as well as the number of radiating elements can vary.

[0090] FIG. **15** depicts a system configuration according to another embodiment, wherein first and second stylets **130**, **131** are disposed within a vessel **406**, such as a vein. In one embodiment, the first stylet **130** is guided by a clinician to one of multiple stenoses **404** present in the vessel **406**, at which point further advancement is ceased. The second stylet **131** can then be introduced into the vessel **406** and guided by the system **10** to another of the stenoses **404**, where further advancement is then ceased. The location of the stenoses can be confirmed and noted using the location ability of the system **10**, wherein remedial procedures can be undertaken to remove the stenoses **404**.

[0091] FIGS. **16** and **17** depict details of the sensor unit **50** according to another embodiment, including a flexible body, or flexible sheet **410**, wherein a plurality of sensors **192** is disposed in a spaced-apart arrangement. Such a flexible sensor unit **50** can enable sensor placement on areas of the patient body, for instance, where curvature or body features would otherwise make sensor unit placement difficult.

[0092] FIG. **17** shows that, in the present embodiment, each sensor **192** disposed within the flexible sheet **410** has positioned adjacent to it an EM coil **414**. So configured, the sensor unit **50** can be shaped as desired before operation of the system **10** is commenced. For instance, the flexible sheet **410** can be bent around a thigh of the patient. Then, the EM

coils 414 of each sensor 192 can be activated so that the system 10 can determine the positional relationship of the sensors via a calibration operation. Thereafter, the sensor unit 50 is ready to be used in detecting EM coils, such as the EM coils 106, 276 described further above. Should the flexible sensor unit 50 be moved or readjusted in placement, another calibration of the sensors 192 would be performed before resuming system operations.

[0093] FIGS. 18A, 18B, and 19 depict details regarding another example of a medical device that can be used with the system 10, in accordance with one embodiment. As shown, a needle assembly 1200 is shown, including a hub 1304 from which extends a hollow cannula 1202. A needle safety component 1320 is included is disposed on a distal end of the hub 1304. A control module 1314 is shown attached to a proximal end of the hub 1304. A hole 1312 is shown defined through the control module 1314 and hub 1304.

[0094] A stylet 1390 extends from the control module 1314 and distally through the hub 1304 via the hole 1312 to extend into the lumen defined by the cannula 1202. A radiating element 1350, such as an EM coil 1392, is disposed proximate a distal end of the stylet 1390. The control module 1314 can include threads so as to threadably engage the needle hub 1304 or other suitable component of the needle or medical component. In this way, the stylet 1390 and associated EM coil 1392 is removably attachable to the needle 1200. Thus, the radiating element 1350 need not be permanently affixed or included with the needle 1200, but rather can be removed therefrom when EM coil-based needle guidance is no longer needed. In addition, this enables the stylet 1390 and control module 1314 to be attached to many different types and sizes of needles. Note that in the present embodiment the distally slidable needle safety component 1320 is configured to safely isolate the distal tip of the needle 1200 upon removal of the needle from the patient.

[0095] The EM coil 1392 of the stylet 1390 as shown here enables the distal tip of the needle 1200 to be tracked and located when it is inserted into a patient in a manner similar to what has been described in previous embodiments, and as depicted in FIG. 20. As shown in FIG. 20, the distal portion of the needle cannula 1202 is shown inserted into the body of the patient. The stylet 1390 is inserted into the cannula 1202 such that the EM coil 1392 is disposed proximate the distal end of the cannula. Additionally, the datum module 158, including its own EM coil 276 (FIGS. 7B, 8), is disposed on a skin surface above the subcutaneous needle cannula 1202. In this configuration, the system 10 is able to track and depict on the display 30 the locations of the EM coils 276, 1392 of the datum module 158 and the needle stylet 1390, respectively, using the detection thereof by the sensor unit 50. This in turn enables the clinician to accurately guide the distal end of the needle cannula 1202 to a desired location within the patient body. Thus, the present embodiment of FIGS. 18A-19 serves as one of many examples of medical devices that can be tracked and guided by the present system 10.

[0096] FIGS. 21 and 22 depict details regarding another example of a medical device that can be used with the system 10, in accordance with one embodiment. As shown, a marker device, such as a breast marker 1400, includes in the present embodiment a radiating element 1450. The radiating element 1450 in the present embodiment is a

reactive or resonating type of EM coil, which resonates electromagnetically when induced by an external field provided by a suitable power source. As shown in FIG. 22, in one example implementation multiple breast markers 1400 are disposed in breast tissue 1460 of a patient, wherein each breast marker includes a resonating-type radiating element 1450. The datum module 158, including its EM coil 276, is placed on a skin surface of the breast. The sensor unit 50 can be placed in proximity to the breast to enable the location of the breast markers 1400 and the datum module 158 to be detected and located by the system 10, thus enabling the clinician to determine the location of the breast markers at some point in time after initial implantation of the breast markers. Note that in one embodiment the sensor unit 50 includes a suitable power source to produce the responsive electromagnetic fields in the resonating-type radiating elements 1450 of the breast markers 1400. Thus, this serves as yet another example of a medical device that can benefit from the tracking and location ability of the system 10.

[0097] Note that further details regarding untethered stylets and tracking systems can be found in U.S. Pat. No. 9,526,440, filed Jun. 19, 2014, and entitled "System for Placement of a Catheter Including a Signal-Generating Stylet," which is incorporated herein by reference in its entirety. Note further that other guidance modalities can be included with the system 10, including permanent magnet-based tracking, ultrasound imaging, and ECG-related guidance.

[0098] Embodiments of the invention may be embodied in other specific forms without departing from the spirit of the present disclosure. The described embodiments are to be considered in all respects only as illustrative, not restrictive. The scope of the embodiments is, therefore, indicated by the appended claims rather than by the foregoing description. All changes that come within the meaning and range of equivalency of the claims are to be embraced within their scope.

What is claimed is:

1. A system for tracking a medical device with respect to a body of a patient, comprising:

a display;

a first radiating element included with the medical device, the first radiating element capable of producing a first electromagnetic field;

a second radiating element capable of producing a second electromagnetic field, the second radiating element positioned with respect to the body of the patient; and

a sensor unit operably connected to the display, the display configured for depiction of information relating to detection by the sensor unit of the first and second electromagnetic fields of the first and second radiating elements.

2. The system as defined in claim 1, wherein the sensor unit includes an array of sensors configured to detect the first and second electromagnetic fields.

3. The system as defined in claim 2, wherein the display is included in a console and wherein the sensor unit is operably connected to the console.

4. The system as defined in claim 1, wherein the sensor unit is movable and is configured for placement on a portion of the patient body.

5. The system as defined in claim 1, wherein at least one of the first and second radiating elements is configured for un-tethered operation with respect to other components of the system.

6. The system as defined in claim 3, wherein each of the first and second radiating elements includes a unique characteristic with respect to the respective one of the first and second electromagnetic fields produced thereby.

7. The system as defined in claim 6, wherein the unique characteristic includes at least one of a frequency and a wavelength of the respective first and second electromagnetic fields.

8. The system as defined in claim 7, wherein the unique characteristic can be changed via communication between the console and the respective one of the first and second radiating elements.

9. The system as defined in claim 8, wherein each of the first and second radiating elements is configured to communicate with a console of the system data relating to the unique characteristic of the respective first or second radiating element.

10. The system as defined in claim 9, wherein each of the first and second radiating elements includes a timer circuit and further includes a transmitter to transmit data relating to the timer circuitry to the console.

11. The system as defined in claim 1, wherein at least one of the first and second radiating elements includes an electromagnetic coil.

12. The system as defined in claim 1, wherein the first radiating element includes an first electromagnetic coil that is included with a stylet, the stylet removably insertable into a lumen of a catheter, the catheter configured for insertion into a vessel or internal portion of the patient body, wherein detection of the first electromagnetic coil enables the system to determine a location of a distal end of the catheter.

13. The system as defined in claim 12, wherein the second radiating element includes a second electromagnetic coil that is included in datum module, the module positionable on an external portion of the patient body, wherein detection of the second electromagnetic coil enable the system to determine the location of the catheter with respect to the datum module.

14. The system as defined in claim 13, wherein the datum module is placed proximate an external landmark of the patient body.

15. The system as defined in claim 14, wherein a detected position of the first and second electromagnetic coils is depicted on the display, the display further depicting a representation of a portion of the patient body.

16. The system as defined in claim 15, wherein a detected position of the first and second electromagnetic coils is depicted on the display by respective first and second icons.

17. The system as defined in claim 1, further comprising at least two radiating elements included with respective medical devices.

18. The system as defined in claim 1, further comprising at least two radiating elements respectively included with first and second datum modules.

19. The system as defined in claim 1, wherein an additional radiating element is included with the first radiating element on a stylet, the stylet removably disposable in a lumen of a catheter.

20. The system as defined in claim 1, wherein the first radiating element is included on a first stylet, and a third

radiating element is included on a second stylet, the stylets configured for placement in a vessel of a patient body.

21. A radiating element assembly for locating a portion of a medical device within a body of a patient, comprising:

a first radiating element included with the medical device, the first radiating element capable of producing a first electromagnetic field; and

a second radiating element capable of producing a second electromagnetic field, the second radiating element positioned with respect to the body of the patient,

wherein the first and second electromagnetic fields are configured for detection by a sensor unit placed with respect to the patient, the sensor unit including a plurality of sensors, wherein the detection by the sensor unit of the first and second electromagnetic fields is usable to locate the medical device within the patient body.

22. The assembly as defined in claim 21, wherein the medical device includes a needle assembly.

23. The assembly as defined in claim 22, wherein the first radiating element is included with a stylet that is removably disposable within a lumen of the needle.

24. The assembly as defined in claim 21, wherein the medical device includes a marker device configured for placement within the patient body, the first radiating element include a resonating-type radiating element that resonates electromagnetically when energized by electromagnetic radiation.

25. The assembly as defined in claim 24, wherein the marker device is a breast marker.

26. The assembly as defined in claim 21, wherein the second radiating element is included in a datum module that is positionable on a portion of the patient body.

27. The assembly as defined in claim 21, wherein the medical device includes a catheter that is configured for insertion proximate a leg of the patient body.

28. The assembly as defined in claim 21, wherein the sensor unit is positionable on one of a plurality of locations on the patient body including a chest portion of the patient.

29. The assembly as defined in claim 21, further comprising a control module for controlling operation of at the first radiating element.

30. The assembly as defined in claim 29, wherein the control module is capable of wirelessly transmitting at least one characteristic of the first electromagnetic field produced by the first radiating element.

31. The assembly as defined in claim 30, wherein the at least one characteristic is transmitted between the control module and a component of a system for assisting in placement of the medical device.

32. The locator as defined in claim 30, further comprising a phase locking circuit for synchronizing a frequency of the first electromagnetic field produced by the first radiating element.

33. The locator as defined in claim 30, wherein the characteristic that is wirelessly transmitted is transmitted using one of visible, infrared, and RF radiation.

34. The assembly as defined in claim 21, wherein a system associated with the assembly is capable of determining a distance between the first and second radiating elements as detected by sensor unit.

35. The assembly as defined in claim 21, wherein the sensor unit includes a flexible body, a plurality of sensors disposed with the flexible body.

36. The assembly as defined in claim **35**, wherein each sensor disposed with the flexible body includes an electromagnetic coil configured to enable calibration of the sensors.

37. A system for tracking insertion of a catheter into a body of a patient, comprising:

a console including a display;

a stylet configured for removable placement in a lumen of the catheter;

a first electromagnetic coil included with the stylet, the first electromagnetic coil capable of producing a first electromagnetic field;

a datum module including a second electromagnetic coil capable of producing a second electromagnetic field, the datum module positioned with respect to the body of the patient; and

a sensor unit operably connected to the console for depiction on the display of information relating to detection by the sensor unit of the first and second electromagnetic fields of the first and second electromagnetic coils.

38. The system as defined in claim **37**, wherein the depiction of the display of information relating to detection

by the sensor unit of the first and second electromagnetic fields of the first and second electromagnetic coils enables a clinician to determine a position of the catheter with respect to the body of the patient.

39. The system as defined in claim **38**, wherein the first electromagnetic coil included with the stylet is configured to be proximate a distal end of that catheter such that detection of the first electromagnetic coil indicates a position of the distal end of the catheter.

40. The system as defined in claim **39**, wherein each of the first and second electromagnetic coils produce electromagnetic fields of unique frequency and/or wavelength.

41. The system as defined in claim **40**, wherein the datum module is configured for placement proximate a skin surface of the patient body so as to provide a reference point when the datum module is detected by the sensor unit.

42. The system as defined in claim **41**, wherein the sensor unit is configured for placement one at least one of a bedside and a portion of the patient body.

* * * * *

专利名称(译)	用于跟踪医疗设备的多线圈系统		
公开(公告)号	US20170215762A1	公开(公告)日	2017-08-03
申请号	US15/418475	申请日	2017-01-27
申请(专利权)人(译)	C. R. BARD , INC.		
当前申请(专利权)人(译)	C. R. BARD , INC.		
[标]发明人	BURNSIDE EDDIE K MESSERLY SHAYNE		
发明人	BURNSIDE, EDDIE K. MESSERLY, SHAYNE		
IPC分类号	A61B5/06 A61B5/00 A61B90/00 A61B5/055		
CPC分类号	A61B5/066 A61B5/055 A61B5/742 A61B5/6852 A61B2090/3958 A61B90/39 A61B2560/0223 A61B2560/0214 A61B2090/3908 A61B5/6848 A61B5/062 A61B2034/2051 A61B2090/397 A61B2562/046		
优先权	62/289126 2016-01-29 US		
外部链接	Espacenet USPTO		

摘要(译)

公开了一种用于跟踪一个或多个医疗装置的位置以便插入患者体内的系统。该系统还可以用于在放置之后的稍后时间定位一个或多个医疗设备。本系统采用多个辐射元件，其可以由系统的传感器单元同时检测，其中至少一个辐射元件包括在医疗装置中。另一个辐射元件可以放置在患者皮肤上的预定点处，以用作界标，以帮助确定医疗装置相对于界标的位置。通过传感器单元检测辐射元件使得辐射元件的相对位置能够在显示器上被确定和描绘，以帮助临床医生准确地定位医疗装置，例如导管。

