



US 20170020604A1

(19) **United States**

(12) **Patent Application Publication**
LOPES et al.

(10) **Pub. No.: US 2017/0020604 A1**

(43) **Pub. Date: Jan. 26, 2017**

(54) **HIGH-DENSITY ELECTRODE-BASED MEDICAL DEVICE SYSTEM**

isional application No. 61/485,987, filed on May 13, 2011, provisional application No. 61/488,639, filed on May 20, 2011, provisional application No. 61/515,141, filed on Aug. 4, 2011.

(71) Applicant: **Kardium Inc.**, Burnaby (CA)

(72) Inventors: **Fernando Luis de Souza LOPES**, Delta (CA); **Saar MOISA**, Vancouver (CA); **Peter Josiah HAWES**, Burnaby (CA)

(21) Appl. No.: **15/287,988**

(22) Filed: **Oct. 7, 2016**

Publication Classification

- (51) **Int. Cl.**
A61B 18/14 (2006.01)
A61B 5/00 (2006.01)
A61B 5/04 (2006.01)
- (52) **U.S. Cl.**
CPC *A61B 18/1492* (2013.01); *A61B 5/04* (2013.01); *A61B 5/6858* (2013.01); *A61B 2562/0209* (2013.01); *A61B 2562/04* (2013.01); *A61B 2018/0016* (2013.01)

Related U.S. Application Data

- (63) Continuation of application No. 13/793,213, filed on Mar. 11, 2013, now Pat. No. 9,480,525, which is a continuation-in-part of application No. PCT/US2012/022061, filed on Jan. 20, 2012, said application No. 13/793,213 is a continuation-in-part of application No. PCT/US2012/022062, filed on Jan. 20, 2012.
- (60) Provisional application No. 61/723,311, filed on Nov. 6, 2012, provisional application No. 61/670,881, filed on Jul. 12, 2012, provisional application No. 61/649,734, filed on May 21, 2012, provisional application No. 61/734,750, filed on Dec. 7, 2012, provisional application No. 61/435,213, filed on Jan. 21, 2011, provisional application No. 61/485,987, filed on May 13, 2011, provisional application No. 61/488,639, filed on May 20, 2011, provisional application No. 61/515,141, filed on Aug. 4, 2011, provisional application No. 61/435,213, filed on Jan. 21, 2011, provi-

(57) **ABSTRACT**

A medical device system is disclosed including a high-density arrangement of transducers, which may be configured to ablate, stimulate, or sense characteristics of tissue inside a bodily cavity, such as an intra-cardiac cavity. High-density arrangements of transducers may be achieved, at least in part, by overlapping elongate members on which the transducers are located, and varying sizes, shapes, or both of the transducers, especially in view of the overlapping of the elongate members. Also, the high-density arrangements of transducers may be achieved, at least in part, by including one or more recessed portions in an elongate member in order to expose one or more transducers on an underlying elongate member in a region adjacent an elongate-member-overlap region.

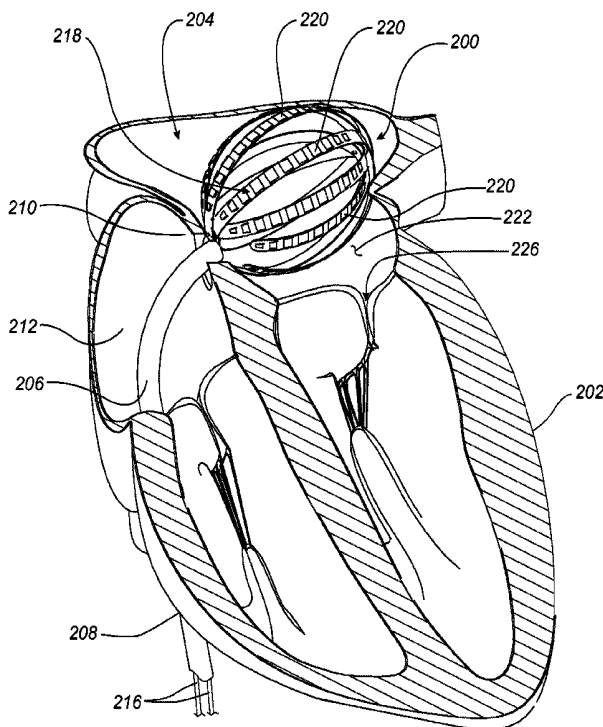

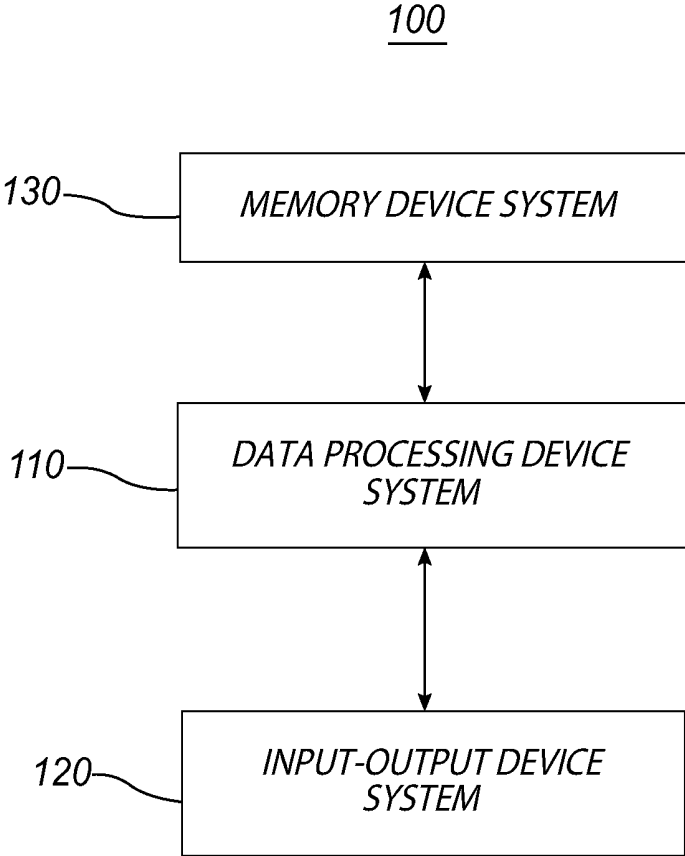

FIG. 1

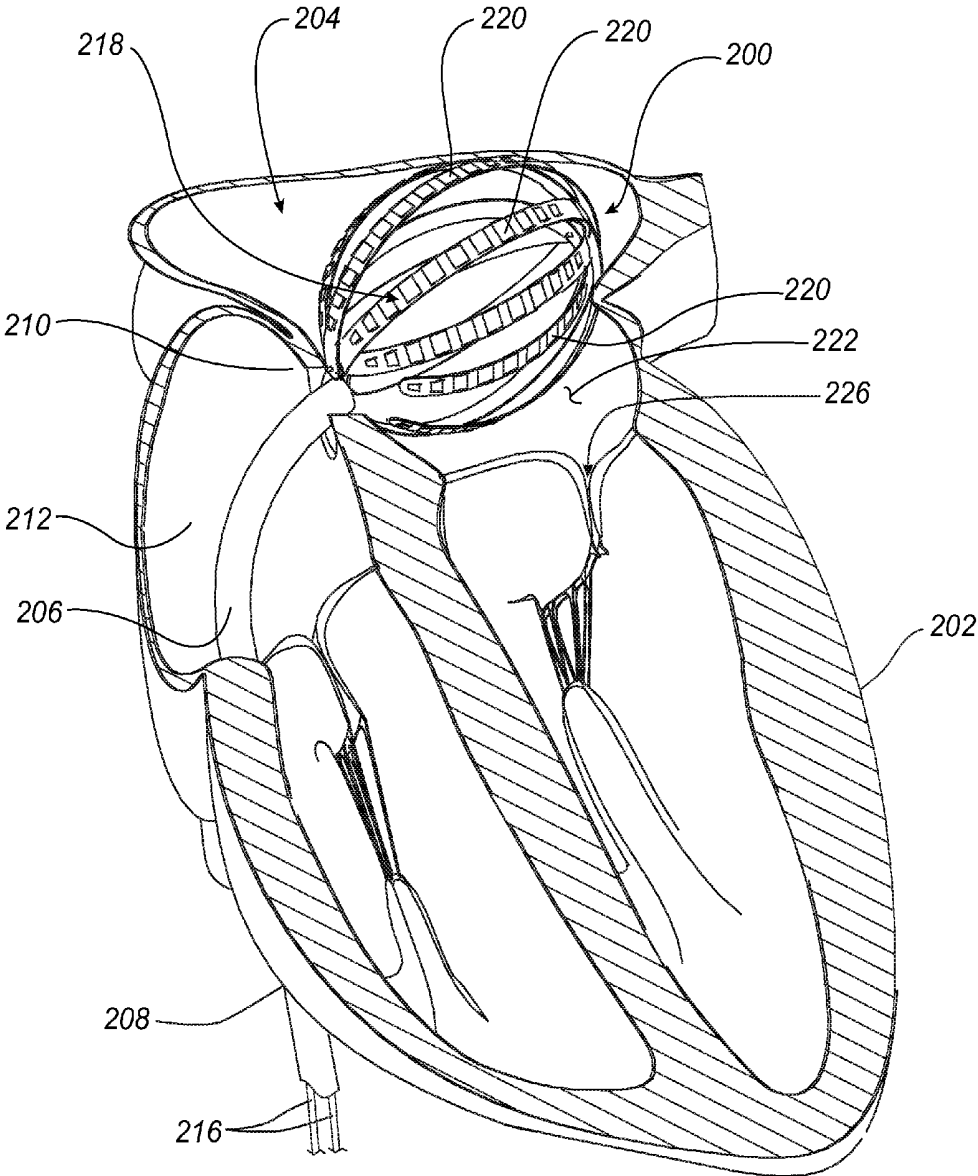

FIG. 2

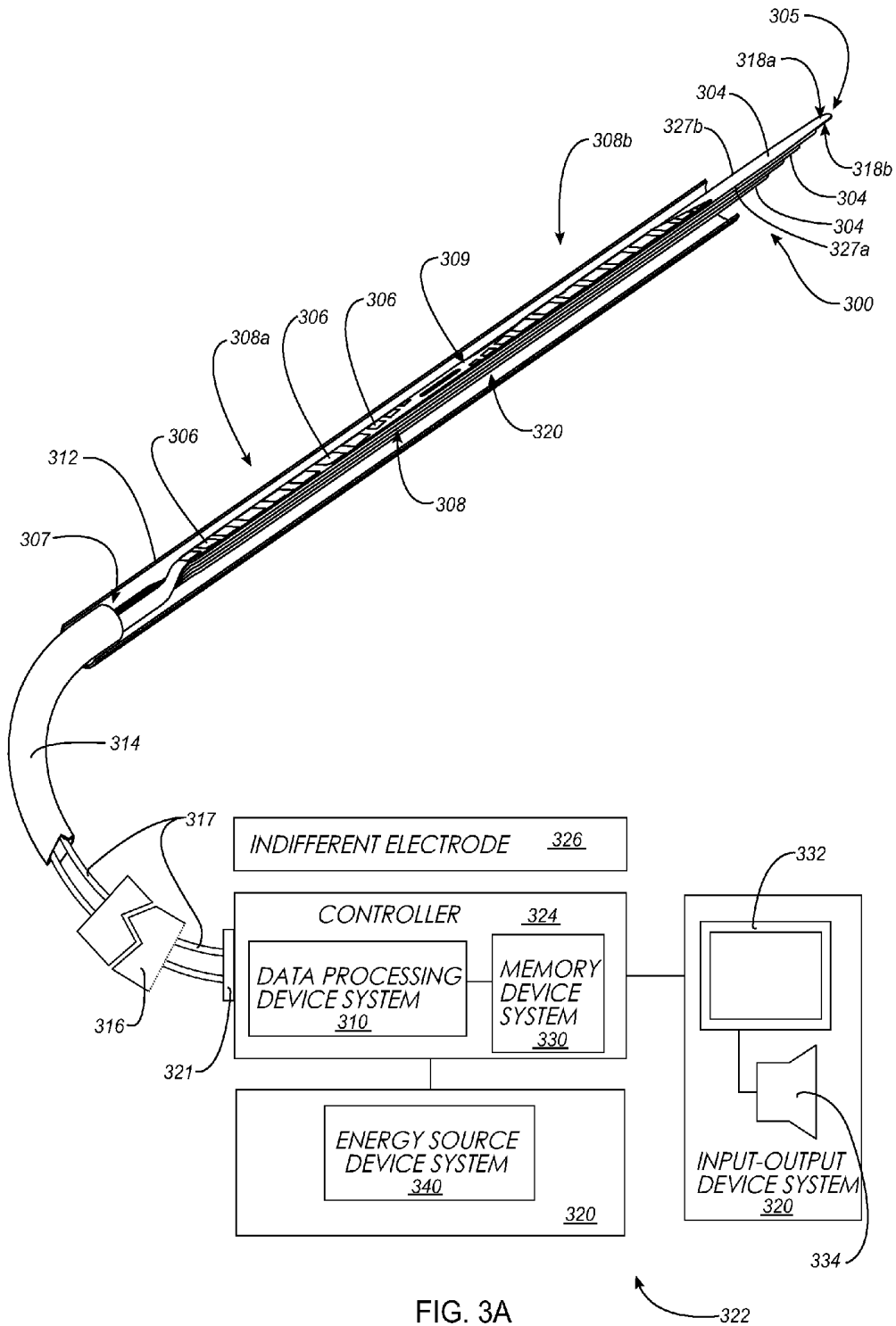

FIG. 3A

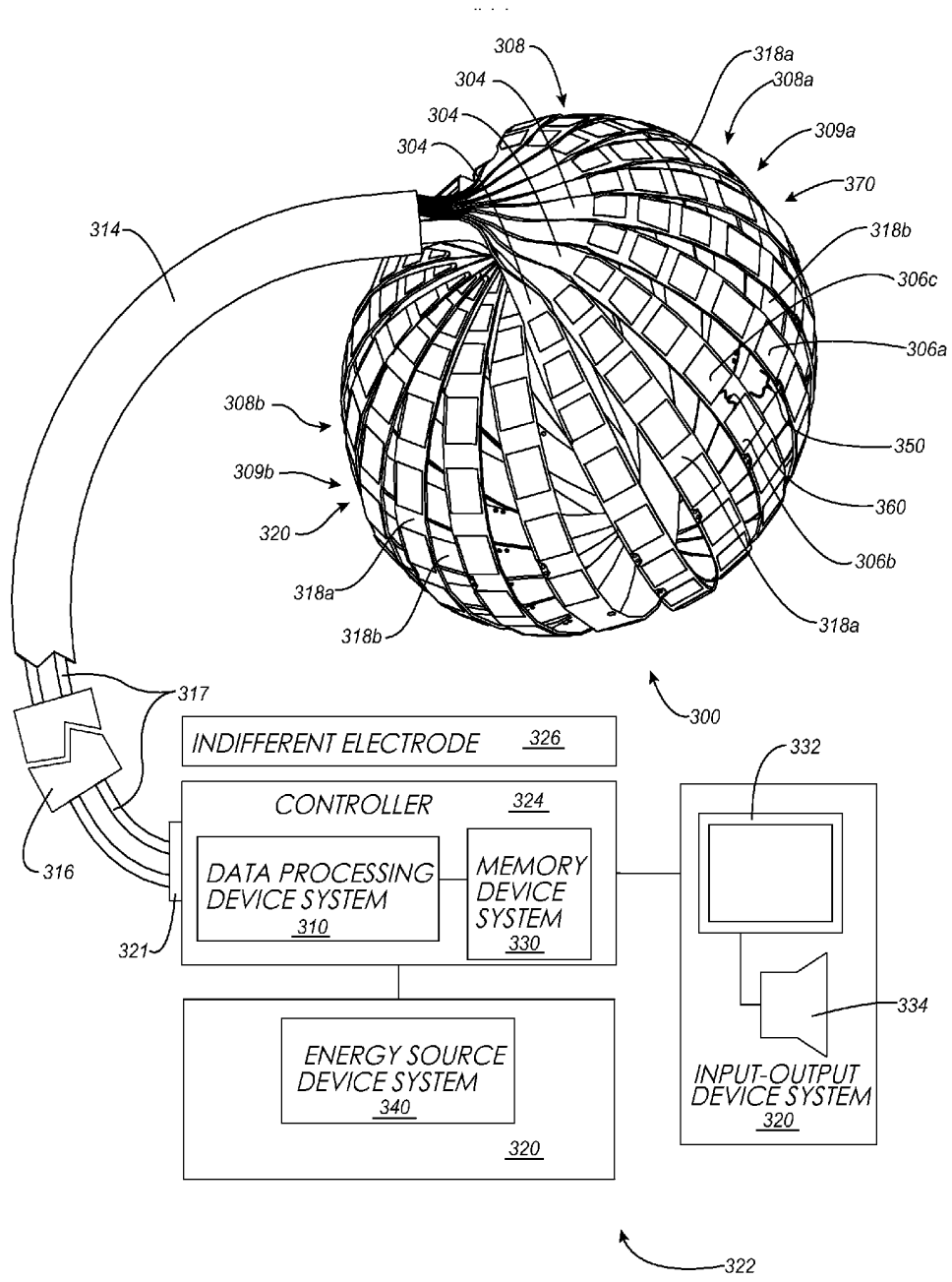

FIG. 3B

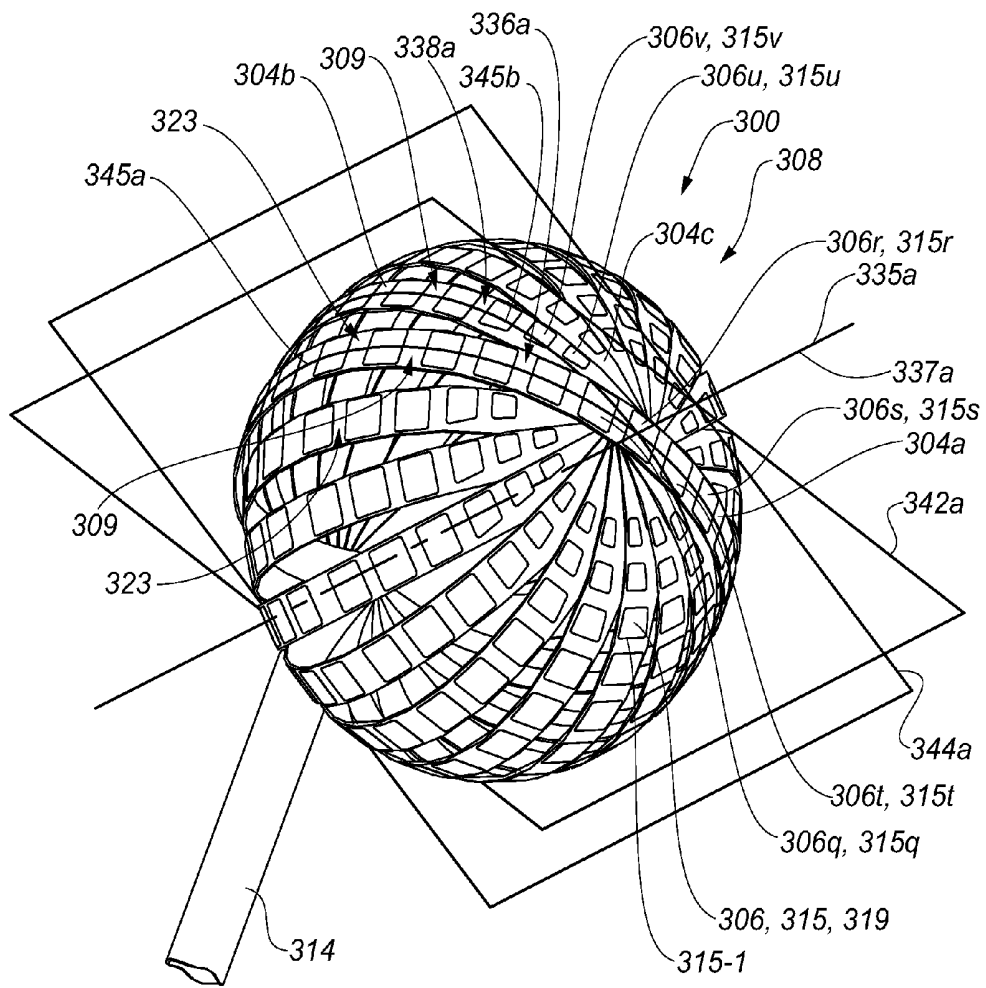

FIG. 3C

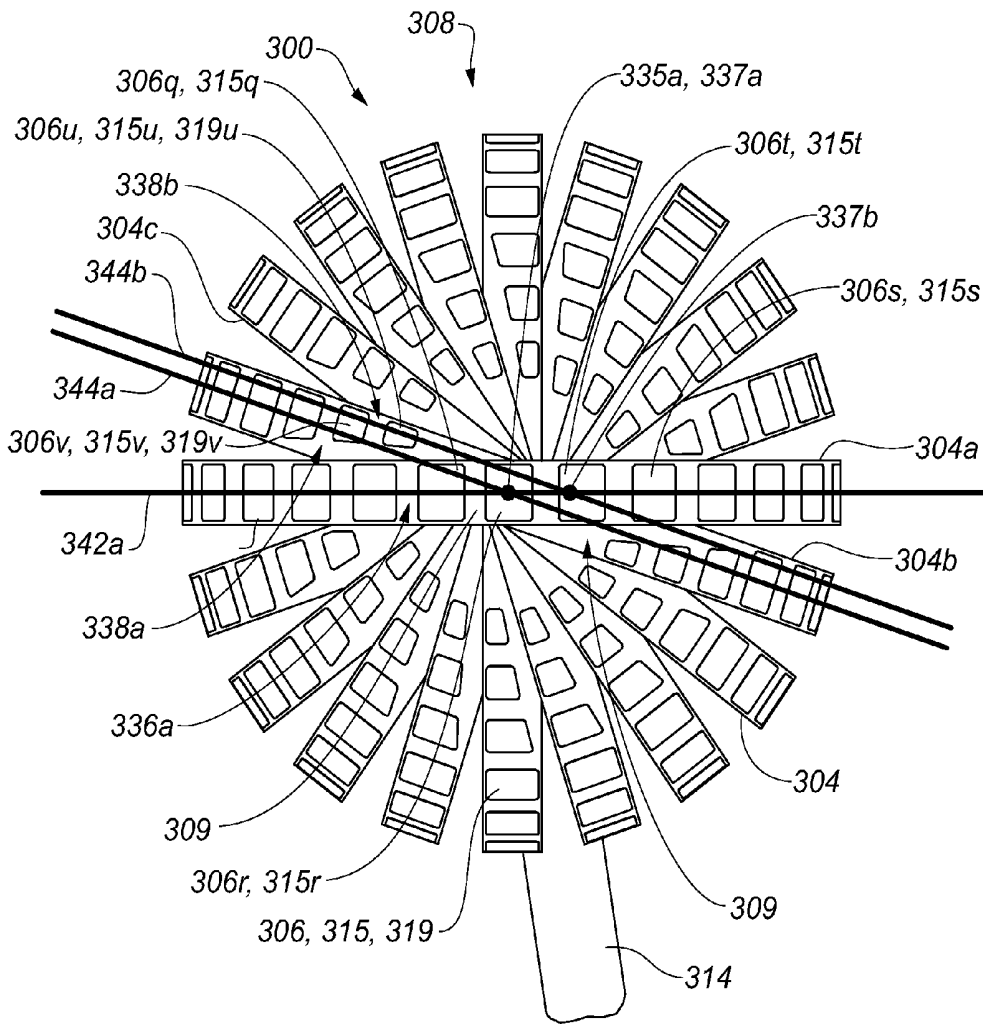

FIG. 3D

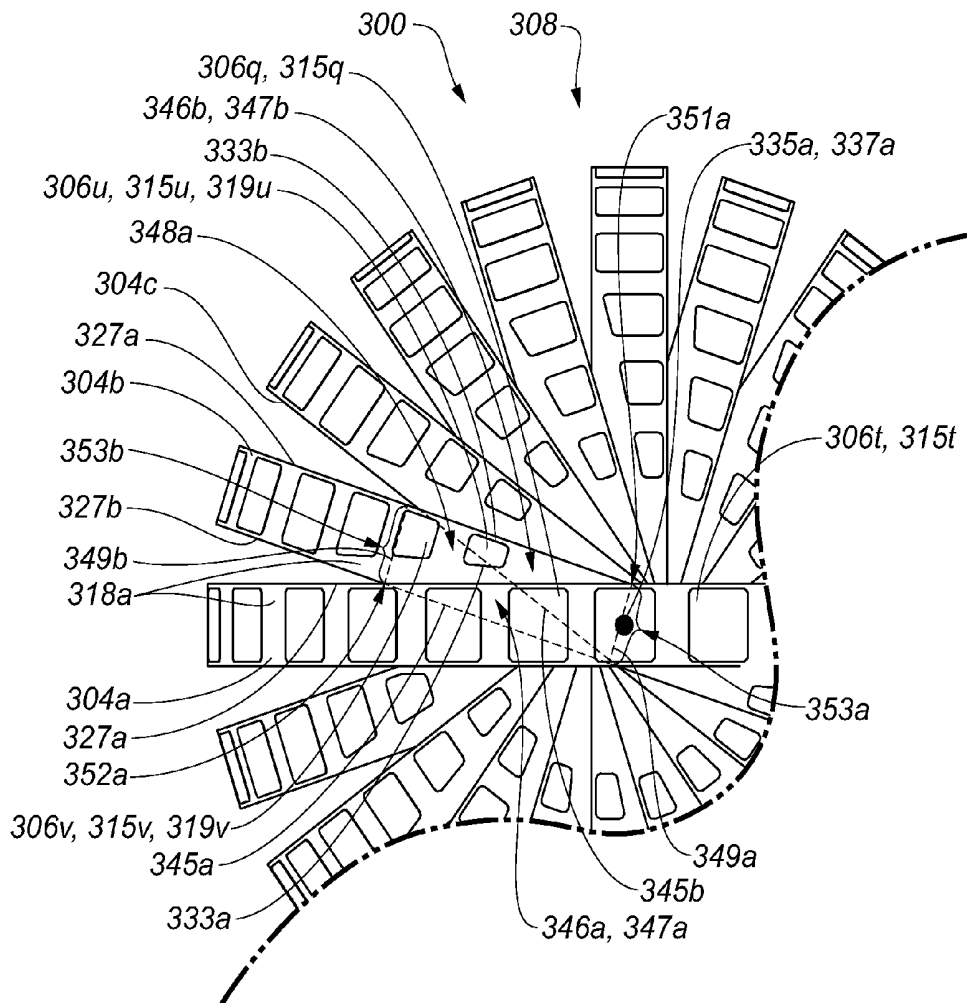

FIG. 3E

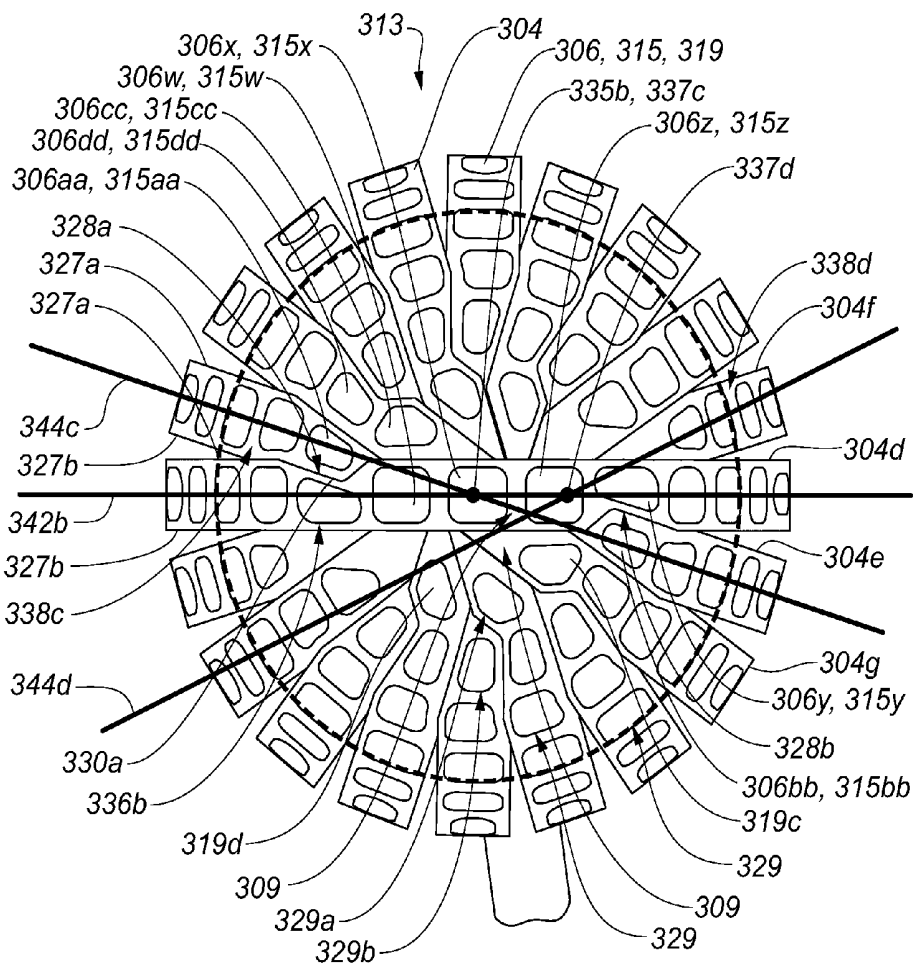

FIG. 3G

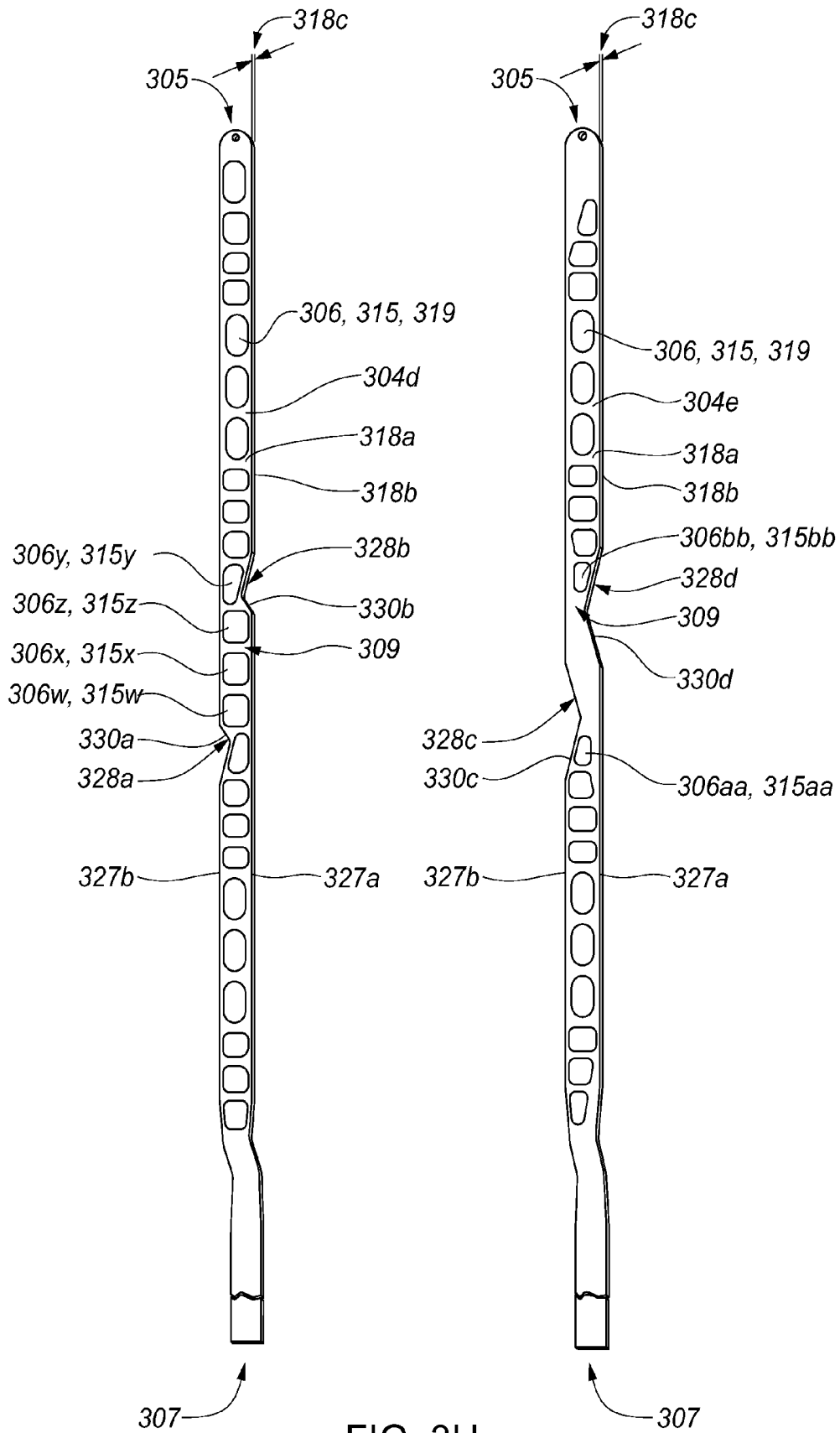

FIG. 3H

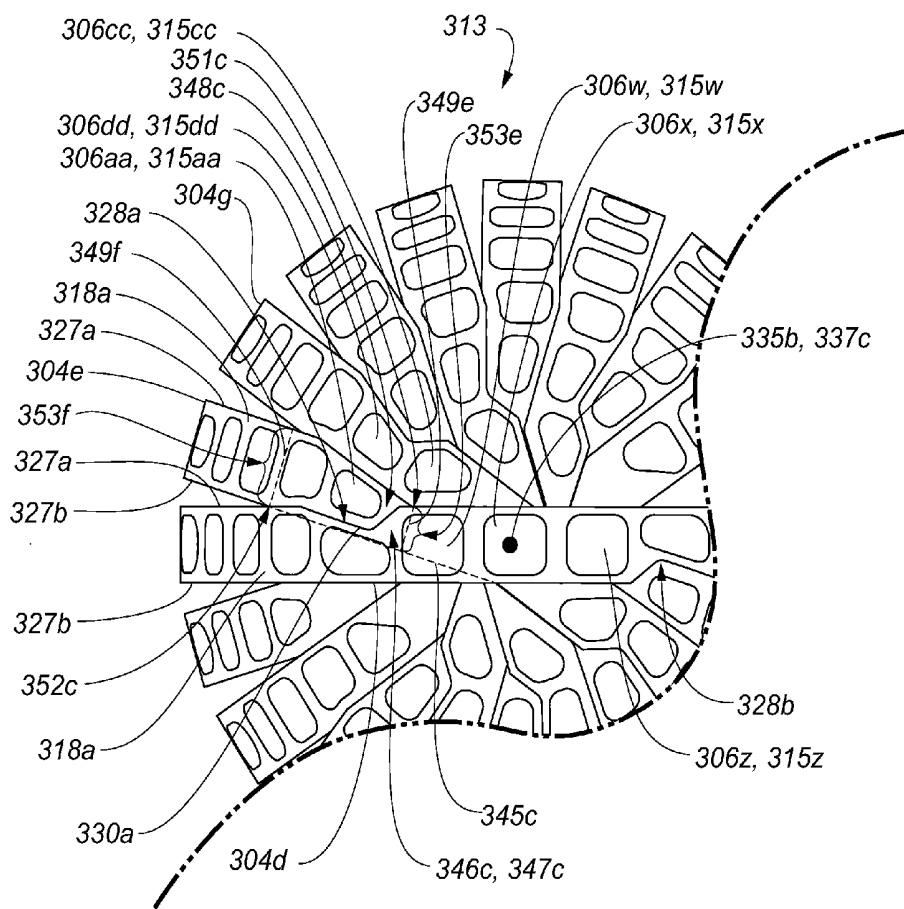

FIG. 3I

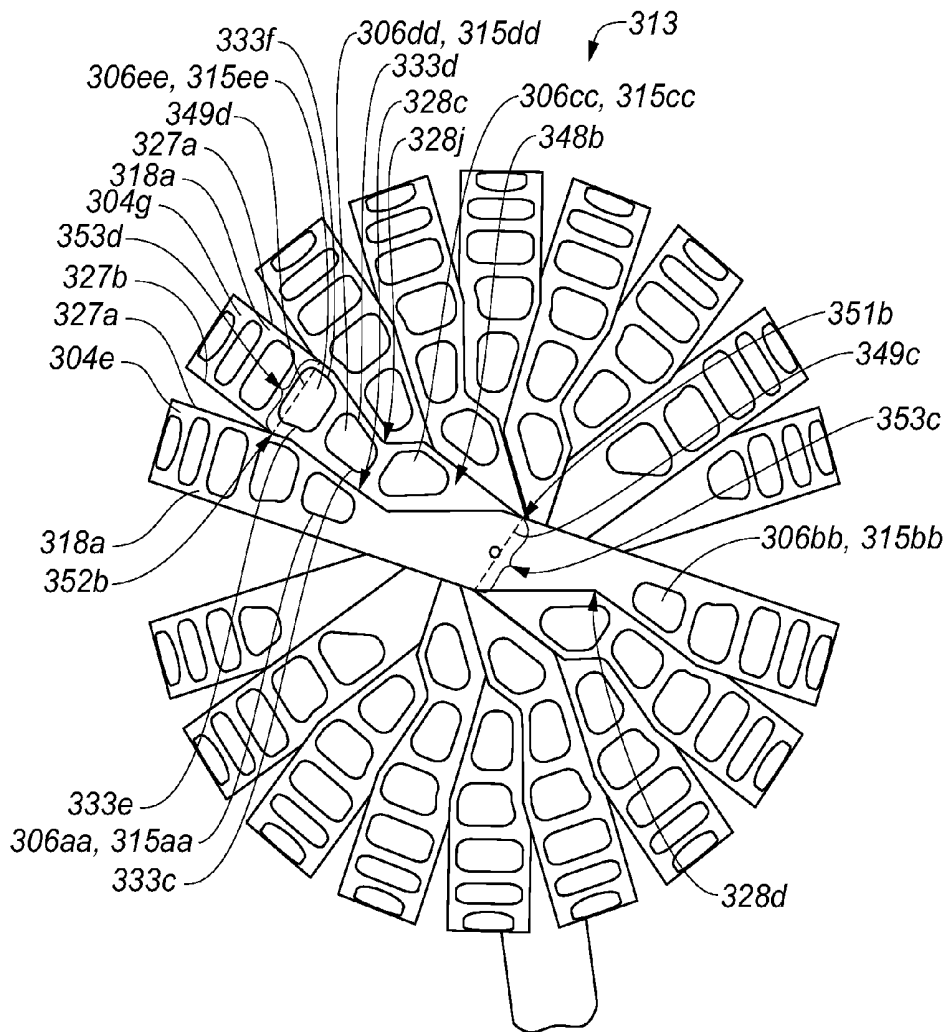

FIG. 3J

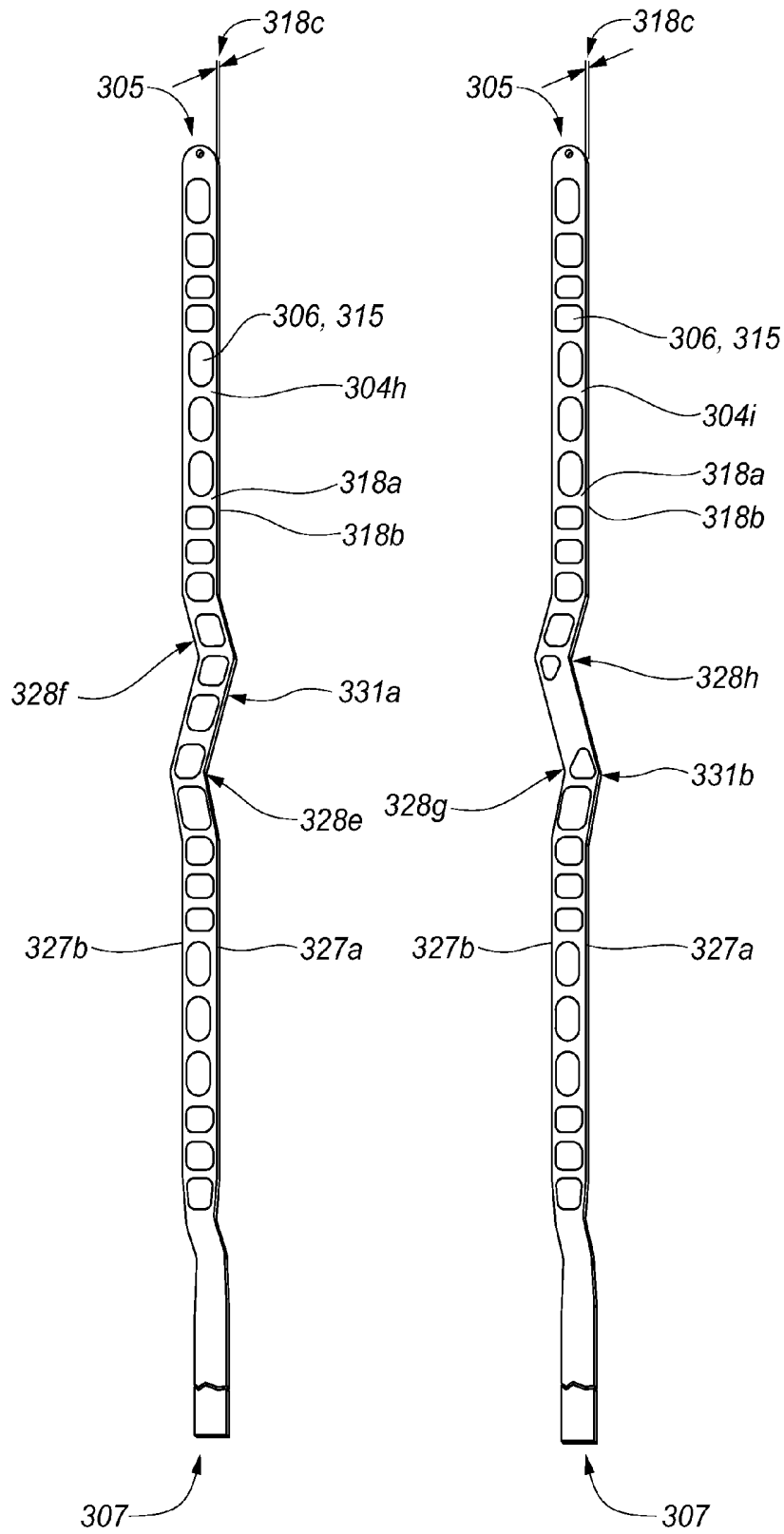

FIG. 3K

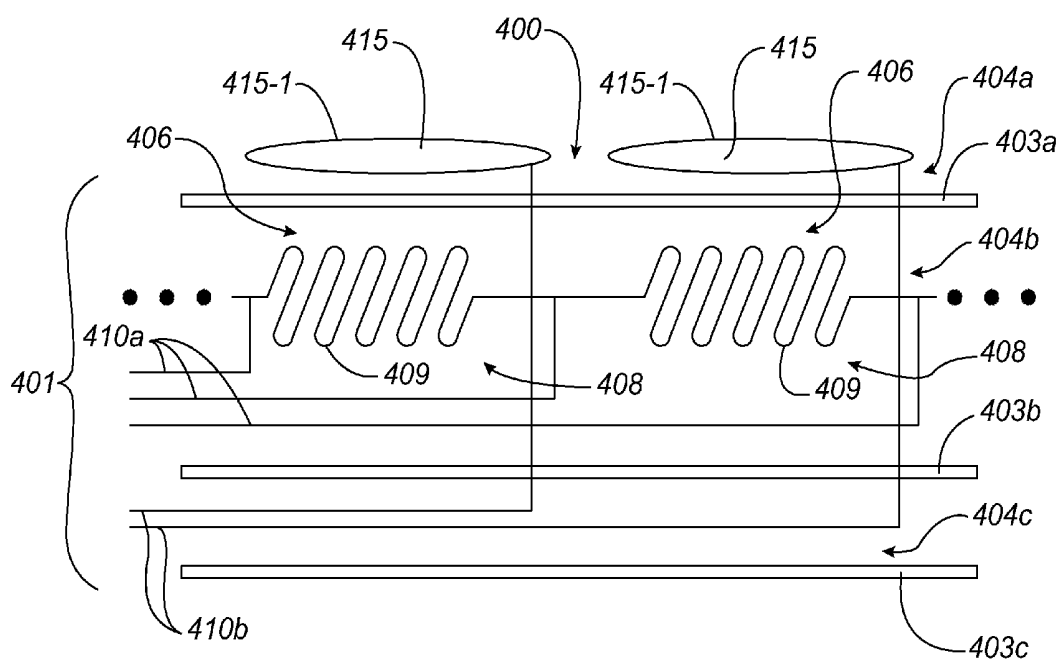

FIG. 4

HIGH-DENSITY ELECTRODE-BASED MEDICAL DEVICE SYSTEM

CROSS-REFERENCE TO RELATED APPLICATIONS

[0001] This application is a continuation of U.S. patent application Ser. No. 13/793,213, filed Mar. 11, 2013, which:

[0002] (a) is a continuation-in-part of prior International Application No. PCT/US2012/022061, which has an international filing date of Jan. 20, 2012, and which claims the benefit of each of U.S. Provisional Application No. 61/435,213, filed Jan. 21, 2011; U.S. Provisional Application No. 61/485,987, filed May 13, 2011; U.S. Provisional Application No. 61/488,639, filed May 20, 2011; and U.S. Provisional Application No. 61/515,141, filed Aug. 4, 2011;

[0003] (b) is a continuation-in-part of prior International Application No. PCT/US2012/022062, which has an international filing date of Jan. 20, 2012, and which claims the benefit of each of U.S. Provisional Application No. 61/435,213, filed Jan. 21, 2011; U.S. Provisional Application No. 61/485,987, filed May 13, 2011; U.S. Provisional Application No. 61/488,639, filed May 20, 2011; and U.S. Provisional Application No. 61/515,141, filed Aug. 4, 2011; and

[0004] (c) claims the benefit of each of U.S. Provisional Application No. 61/649,734, filed May 21, 2012; U.S. Provisional Application No. 61/670,881, filed Jul. 12, 2012; U.S. Provisional Application No. 61/723,311, filed Nov. 6, 2012; and U.S. Provisional Application No. 61/734,750, filed Dec. 7, 2012. The entire disclosure of each of the applications cited in this Cross-Reference to Related Applications Section is hereby incorporated herein by reference.

TECHNICAL FIELD

[0005] Aspects of this disclosure generally are related to a medical device system including a high-density arrangement of transducers. In some embodiments, the transducers are configured to ablate or sense characteristics of tissue inside a bodily cavity.

BACKGROUND

[0006] Cardiac surgery was initially undertaken using highly invasive open procedures. A sternotomy, which is a type of incision in the center of the chest that separates the sternum was typically employed to allow access to the heart. In the past several decades, more and more cardiac operations are performed using intravascular or percutaneous techniques, where access to inner organs or other tissue is gained via a catheter.

[0007] Intravascular or percutaneous surgeries benefit patients by reducing surgery risk, complications and recovery time. However, the use of intravascular or percutaneous technologies also raises some particular challenges. Medical devices used in intravascular or percutaneous surgery need to be deployed via catheter systems which significantly increase the complexity of the device structure. As well, doctors do not have direct visual contact with the medical devices once the devices are positioned within the body.

[0008] One example of where intravascular or percutaneous medical techniques have been employed is in the treatment of a heart disorder called atrial fibrillation. Atrial fibrillation is a disorder in which spurious electrical signals cause an irregular heartbeat. Atrial fibrillation has been treated with open heart methods using a technique known as

the "Cox-Maze procedure". During this procedure, physicians create specific patterns of lesions in the left and right atria to block various paths taken by the spurious electrical signals. Such lesions were originally created using incisions, but are now typically created by ablating the tissue with various techniques including radio-frequency (RF) energy, microwave energy, laser energy and cryogenic techniques. The procedure is performed with a high success rate under the direct vision that is provided in open procedures, but is relatively complex to perform intravascularly or percutaneously because of the difficulty in creating the lesions in the correct locations. Various problems, potentially leading to severe adverse results, may occur if the lesions are placed incorrectly. It is particularly important to know the position of the various transducers which will be creating the lesions relative to cardiac features such as the pulmonary veins and mitral valve. The continuity, transmural, and placement of the lesion patterns that are formed can impact the ability to block paths taken within the heart by spurious electrical signals. Other requirements for various ones of the transducers to perform additional functions such as, but not limited to, mapping various anatomical features, mapping electrophysiological activity, sensing tissue characteristics such as impedance and temperature and tissue stimulation can also complicate the operation of the employed medical device.

[0009] However, conventional transducer-based intra-bodily-cavity devices have relatively few transducers due to conventional technological limitations and, consequently, have difficulty gathering adequate information and performing proper lesion formation. Accordingly, a need in the art exists for improved intra-bodily-cavity transducer-based devices.

SUMMARY

[0010] At least the above-discussed need is addressed and technical solutions are achieved by various embodiments of the present invention. In some embodiments, device systems exhibit enhanced capabilities for the deployment and the activation of various transducers, which may be located within a bodily cavity, such as an intra-cardiac cavity. In some embodiments, systems or a portion thereof may be percutaneously or intravascularly delivered to position the various transducers within the bodily cavity. Various ones of the transducers may be activated to distinguish tissue from blood and may be used to deliver positional information of the device relative to various anatomical features in the bodily cavity, such as the pulmonary veins and mitral valve in an atrium. Various ones of the transducers may employ characteristics such as blood flow detection, impedance change detection or deflection force detection to discriminate between blood and tissue. Various ones of the transducers may be used to treat tissue within a bodily cavity. Treatment may include tissue ablation by way of non-limiting example. Various ones of the transducers may be used to stimulate tissue within the bodily cavity. Stimulation can include pacing by way of non-limiting example. Other advantages will become apparent from the teaching herein to those of skill in the art.

[0011] In some embodiments, a medical device system may be summarized as including a structure that includes a plurality of elongate members, each of the elongate members including a proximal end, a distal end, and an intermediate portion between the proximal and distal ends. The

medical device system further includes a plurality of electrodes located on the structure, the plurality of electrodes positionable in a bodily cavity. A first group of the electrodes is located on a first elongate member of the plurality of elongate members and a second group of the electrodes is located on a second elongate member of the plurality of elongate members. The structure is selectively moveable between a delivery configuration in which the structure is sized to be percutaneously delivered to the bodily cavity and a deployed configuration in which the structure is expanded to have a size too large to be percutaneously delivered to the bodily cavity. The intermediate portions of the elongate members are angularly arranged with respect to one another about a first axis when the structure is in the deployed configuration. Each electrode of the first group of the electrodes is intersected by a first plane having no thickness and each electrode of the second group of the electrodes is intersected by a second plane having no thickness when the structure is in the deployed configuration. The first and the second planes are non-parallel planes that intersect each other along a second axis, and at least a first electrode of the plurality of electrodes is intersected by each of the first plane and the second plane when the structure is in the deployed configuration. The first electrode is not intersected by each of the first axis and the second axis when the structure is in the deployed configuration.

[0012] In some embodiments, the second axis is parallel to the first axis. In some embodiments, the first axis and the second axis are collinear. In some embodiments, the first axis intersects at least one other electrode of the plurality of electrodes that does not include the first electrode when the structure is in the deployed configuration. In some embodiments, the second axis intersects at least one other electrode of the plurality of electrodes that does not include the first electrode when the structure is in the deployed configuration.

[0013] Each of the plurality of elongate members may include a curved portion having a curvature configured to cause the curved portion to extend along at least a portion of a respective curved path, the curvature configured to cause the curved path to intersect the first axis at each of a respective at least two spaced apart locations along the first axis when the structure is in the deployed configuration. At least some of the plurality of electrodes may be radially spaced about the first axis when the structure is in the deployed configuration. At least some of the plurality of electrodes may be circumferentially arranged about the first axis when the structure is in the deployed configuration. The intermediate portion of the first elongate member may overlap the intermediate portion of the second elongate member at a location on the structure passed through by the first axis when the structure is in the deployed configuration. The intermediate portion of the first elongate member may overlap the intermediate portion of the second elongate member at each of a first location on the structure passed through by the first axis and a second location on the structure passed through by the second axis when the structure is in the deployed configuration. Each of the plurality of elongate members may be arranged to be advanced distal end-first into the bodily cavity when the structure is in the delivery configuration. The intermediate portion of the first elongate member may be adjacent the intermediate portion of the second elongate member when the structure is in the deployed configuration.

[0014] In some embodiments, the first group of the electrodes may include a pair of adjacent ones of the electrodes located on the first elongate member. A region of space associated with a physical portion of the structure may be located between the respective electrodes of the pair of adjacent ones of the electrodes located on the first elongate member, the region of space intersected by the first plane when the structure is in the deployed configuration. The respective electrodes of the first group of the electrodes may be spaced along a length of a portion of the first elongate member, the length of the portion of the first elongate member extending along the first elongate member between the proximal and the distal ends of the first elongate member. The entirety of the length of the portion of the elongate member may be intersected by the first plane when the structure is in the deployed configuration. The first group of the electrodes, the second group of the electrodes, or each of both the first and the second groups of the electrodes may include three or more of the plurality of electrodes.

[0015] In some embodiments, the first plane may intersect every electrode that is located on the first elongate member when the structure is in the deployed configuration. In some embodiments, the second plane may intersect every electrode that is located on the second elongate member when the structure is in the deployed configuration. In some embodiments, the first group of the electrodes includes the first electrode and the second group of the electrodes does not include the first electrode. At least some of the plurality of electrodes may be arranged in a plurality of concentric ringed arrangements when the structure is in the deployed configuration, a first one of the plurality of concentric ringed arrangements having a fewer number of the electrodes than a second one of the plurality of concentric ringed arrangements. The first one of the plurality of concentric ringed arrangements may include the first electrode.

[0016] The first elongate member may include an edge interrupted by a notch, the notch located to expose at least a portion of at least a second electrode located on the second elongate member as viewed towards the second electrode along a direction parallel to a direction that the first axis extends along when the structure is in the deployed configuration. The second group of the electrodes may include the second electrode. The second electrode may be adjacent the first electrode when the structure is in the deployed configuration.

[0017] In some embodiments, the first elongate member may include a surface interrupted by a channel, the channel located to expose at least a portion of at least a second electrode located on the second elongate member as viewed towards the second electrode along a direction parallel to a direction that the first axis extends along when the structure is in the deployed configuration. In some embodiments, the first elongate member may include a jogged portion, the jogged portion undergoing at least one change in direction as the jogged portion extends between the proximal and the distal ends of the first elongate member. The jogged portion may be located to expose at least a portion of at least a second electrode located on the second elongate member as viewed towards the second electrode along a direction parallel to a direction that the first axis extends along when the structure is in the deployed configuration. In some embodiments, the intermediate portion of each elongate member of the plurality of elongate members includes a front surface and a back surface opposite across a thickness

of the elongate member from the front surface. Each intermediate portion further includes a respective pair of side edges of the front surface, the back surface, or both the front surface and the back surface of the intermediate portion. The side edges of each pair of side edges are opposite to one another, each of the side edges of each pair of side edges extending between the proximal end and the distal end of the respective elongate member. The first elongate member may be positioned such that a first edge of the pair of side edges of the first elongate member crosses a second side edge of the pair of side edges of the second elongate member of the plurality of elongate members when the structure is in the deployed configuration. A portion of the first edge may form a recessed portion of the first elongate member that exposes at least a portion of a second electrode located on a portion of the front surface of the second elongate member as viewed normally to the portion of the front surface of the second elongate member when the structure is in the deployed configuration. The second group of the electrodes may include the second electrode.

[0018] In some embodiments, each of the respective intermediate portions of the elongate members each may include a thickness, a front surface, and a back surface opposite across the thickness from the front surface. The respective intermediate portions of the plurality of elongate members may be arranged front surface-toward-back surface in a stacked array when the structure is in the delivery configuration. The structure may further include a proximal portion and a distal portion, each of the proximal and the distal portions including a respective part of each of the plurality of elongate members, the proximal portion of the structure forming a first domed shape and the distal portion of the structure forming a second domed shape when the structure is in the deployed configuration.

[0019] The structure may include a proximal portion and a distal portion with the structure arranged to be advanced distal portion first into the bodily cavity when the structure is in the delivery configuration. In some embodiments, the proximal portion of the structure forms a first domed shape and the distal portion of the structure forms a second domed shape when the structure is in the deployed configuration, the proximal and the distal portions of the structure arranged in a clam shell configuration when the structure is in the deployed configuration.

[0020] In some embodiments, the intermediate portions of at least some of the plurality of elongate members are, when the structure is in the deployed configuration, sufficiently spaced from the first axis to position each of at least some of the plurality of the electrodes at respective locations suitable for contact with a tissue wall of the bodily cavity.

[0021] Various systems may include combinations and subsets of the systems summarized above.

[0022] In some embodiments, a medical device system may be summarized as including a plurality of transducers positionable in a bodily cavity and a structure on which the transducers are located. The structure includes a plurality of elongate members, each of the elongate members including a proximal end, a distal end, an intermediate portion positioned between the proximal end and the distal end, and a thickness. Each intermediate portion includes a front surface and a back surface opposite across the thickness of the elongate member from the front surface, and each intermediate portion further includes a respective pair of side edges of the front surface, the back surface, or both the front

surface and the back surface. The side edges of each pair of side edges are opposite to one another, and the side edges of each pair of side edges extend between the proximal end and the distal end of the respective elongate member. The structure is selectively moveable between a delivery configuration in which the structure is sized for percutaneous delivery to a bodily cavity, and a deployed configuration in which the structure is sized too large for percutaneous delivery to the bodily cavity. At least a first elongate member of the plurality of elongate members is positioned such that a first edge of the pair of side edges of the first elongate member crosses a second side edge of the pair of side edges of a second elongate member of the plurality of elongate members when the structure is in the deployed configuration. A portion of the first edge forms a recessed portion of the first elongate member that exposes at least a portion of a transducer located on a portion of the front surface of the second elongate member as viewed normally to the portion of the front surface of the second elongate member when the structure is in the deployed configuration.

[0023] The recessed portion of the first elongate member may form at least a portion of a notch in the intermediate portion of the first elongate member, the notch extending towards a second edge of the pair of side edges of the first elongate member. The first elongate member may include a jogged portion, the jogged portion undergoing at least one change in direction as the jogged portion extends between the proximal and the distal ends of the first elongate member, the recessed portion of the first elongate member forming at least part of the jogged portion.

[0024] The intermediate portions of the elongate members may be angularly arranged with respect to one another about an axis when the structure is in the deployed configuration. At least some of the plurality of transducers may be radially spaced about an axis when the structure is in the deployed configuration. At least some of the plurality of transducers may be circumferentially arranged about an axis when the structure is in the deployed configuration. At least some of the plurality of transducers may be arranged in a plurality of concentric ringed arrangements when the structure is in the deployed configuration, a first one of the plurality of concentric ringed arrangements having a fewer number of the transducers than a second one of the plurality of concentric ringed arrangements. The first one of the plurality of concentric ringed arrangements may not include any of the plurality of transducers located on the second elongate member. The second one of the plurality of concentric ringed arrangements may include the transducer located on the portion of the front surface of the second elongate member. The first one of the plurality of concentric ringed arrangements may be adjacent the second one of the plurality of concentric ringed arrangements.

[0025] Each of the plurality of elongate members may be arranged to be advanced distal end-first into the bodily cavity when the structure is in the delivery configuration. The respective intermediate portions of the plurality of elongate members may be arranged front surface-toward-back surface in a stacked array when the structure is in the delivery configuration. The structure may further include a proximal portion and a distal portion, each of the proximal and the distal portions including a respective part of each of the plurality of elongate members, the proximal portion of the structure forming a first domed shape and the distal

portion of the structure forming a second domed shape when the structure is in the deployed configuration.

[0026] The structure may include a proximal portion and a distal portion, with the structure arranged to be advanced distal portion first into the bodily cavity when the structure is in the delivery configuration. In some embodiments, the proximal portion of the structure forms a first domed shape and the distal portion of the structure forms a second domed shape when the structure is in the deployed configuration, the proximal and the distal portions of the structure arranged in a clam shell configuration when the structure is in the deployed configuration.

[0027] Various systems may include combinations and subsets of the systems summarized above.

[0028] In some embodiments, a medical device system may be summarized as including a plurality of electrodes positionable in a bodily cavity and a structure on which the electrodes are located. The structure includes a plurality of elongate members. The plurality of electrodes include a plurality of sets of the electrodes, each respective set of the electrodes located on a respective one of the elongate members. Each of the elongate members includes a proximal end, a distal end, an intermediate portion positioned between the proximal end and the distal end, and a thickness. Each intermediate portion includes a front surface and a back surface opposite across the thickness of the elongate member from the front surface. The structure is selectively moveable between a delivery configuration in which the structure is sized for percutaneous delivery to the bodily cavity and a deployed configuration in which the structure is sized too large for percutaneous delivery to the bodily cavity. A first elongate member of the plurality of elongate members is positioned such that a portion of the front surface of the first elongate member overlaps a portion of the respective front surface of each of at least a second elongate member of the plurality of elongate members as viewed normally to the portion of the front surface of the first elongate member when the structure is in the deployed configuration. At least a first electrode of the plurality of electrodes is located at least on the portion of the front surface of the first elongate member, and the portion of the front surface of the second elongate member faces the back surface of the first elongate member at least when the structure is in the deployed configuration.

[0029] Each of the front surfaces of the plurality of elongate members may face an outward direction of the structure when the structure is in the deployed configuration. The portion of the front surface of the second elongate member may face the back surface of the first elongate member when the structure is in the delivery configuration. The portion of the front surface of the second elongate member may contact the back surface of the first elongate member when the structure is in the deployed configuration. Each electrode in each set of the plurality of electrodes may be located solely on the front surface of a respective one of the elongate members.

[0030] The intermediate portions of the elongate members may be angularly arranged with respect to one another about an axis when the structure is in the deployed configuration. At least some of the plurality of electrodes may be radially spaced about the axis when the structure is in the deployed configuration. At least some of the plurality of electrodes may be circumferentially arranged about the axis when the structure is in the deployed configuration. The intermediate

portion of the first elongate member may cross the intermediate portion of the second elongate member at a location on the structure intersected by the axis when the structure is in the deployed configuration. Each of the portion of the front surface of the first elongate member and the portion of the front surface of the second elongate member may be intersected by the axis when the structure is in the deployed configuration. The intermediate portion of the first elongate member may be adjacent the intermediate portion of the second elongate member when the structure is in the deployed configuration. At least one electrode of the plurality of electrodes may be intersected by the axis when the structure is in the deployed configuration. A particular electrode of the at least one electrode may be located adjacently to the first electrode on the portion of the front surface of the first elongate member. At least some of the plurality of electrodes may be arranged in a plurality of concentric ringed arrangements when the structure is in the deployed configuration, a first one of the plurality of concentric ringed arrangements having a fewer number of the electrodes than a second one of the plurality of concentric ringed arrangements. The first one of the plurality of concentric ringed arrangements may include the first electrode.

[0031] Each intermediate portion may further include a respective pair of side edges of the front surface, the back surface, or both the front surface and the back surface of the intermediate portion. The side edges of each pair of side edges are opposite to one another, and each of the side edges of each pair of side edges extend between the proximal end and the distal end of the respective elongate member. The first elongate member may be positioned such that a first edge of the pair of side edges of the first elongate member crosses a second side edge of the pair of side edges of the second elongate member when the structure is in the deployed configuration. A portion of the first edge may form a recessed portion of the first elongate member that exposes at least a portion of a second electrode located on the portion of the front surface of the second elongate member as viewed normally to the portion of the front surface of the second elongate member when the structure is in the deployed configuration.

[0032] Each of the plurality of elongate members may be arranged to be advanced distal end-first into the bodily cavity when the structure is in the delivery configuration. The respective intermediate portions of the plurality of elongate members may be arranged front surface-toward-back surface in a stacked array when the structure is in the delivery configuration. The structure may further include a proximal portion and a distal portion, each of the proximal and the distal portions including a respective part of each of the plurality of elongate members. In some embodiments, the proximal portion of the structure forms a first domed shape and the distal portion of the structure forms a second domed shape when the structure is in the deployed configuration.

[0033] The structure may include a proximal portion and a distal portion, with the structure arranged to be advanced distal portion first into the bodily cavity when the structure is in the delivery configuration. In some embodiments, the proximal portion of the structure forms a first domed shape and the distal portion of the structure forms a second domed shape when the structure is in the deployed configuration,

the proximal and the distal portions of the structure arranged in a clam shell configuration when the structure is in the deployed configuration.

[0034] Various systems may include combinations and subsets of the systems summarized above.

[0035] In some embodiments, a medical device system may be summarized as including a plurality of electrodes positionable in a bodily cavity and a structure on which the electrodes are located. The structure includes a plurality of elongate members, each of the elongate members including a proximal end, a distal end, an intermediate portion positioned between the proximal end and the distal end, and a thickness. Each intermediate portion includes a front surface and a back surface opposite across the thickness of the elongate member from the front surface. Each intermediate portion further includes a respective pair of side edges of the front surface, the back surface, or both the front surface and the back surface. The side edges of each pair of side edges opposite to one another. The side edges of each pair of side edges extend between the proximal end and the distal end of the respective elongate member. The structure is selectively moveable between a delivery configuration in which the structure is sized for percutaneous delivery to a bodily cavity and a deployed configuration in which the structure is sized too large for percutaneous delivery to the bodily cavity. At least a first elongate member of the plurality of elongate members is positioned such that a first side edge of the pair of side edges of the first elongate member crosses a first side edge of the pair of side edges of a second elongate member of the plurality of elongate members at a first location and crosses a second side edge of the pair of side edges of the second elongate member at a second location when the structure is in the deployed configuration. Each of one or more of the plurality of electrodes is wholly located on a portion of the second elongate member, the portion of the second elongate member located between a first transverse line and a second transverse line when the structure is in the deployed configuration, the first transverse line extending across a first width of the second elongate member at the first location, and the second transverse line extending across a second width of the second elongate member at the second location.

[0036] The first width may be different than the second width. The first width and the second width may be widths of the front surface of the second elongate member. The one or more electrodes may include two or more of the plurality of electrodes. At least a portion of an electrode of the plurality of electrodes may be located on the portion of the second elongate member.

[0037] A first electrode of the one or more of the plurality of electrodes may include a first electrode edge that forms part of a periphery of an electrically conductive surface of the first electrode, the first electrode edge arranged to follow a portion of the first side edge of the first elongate member between the first location and the second location when the structure is in the deployed configuration. The first electrode may include a second electrode edge opposite across the electrically conductive surface from the first electrode edge, the second electrode edge forming part of the periphery of the electrically conductive surface of the first electrode. The second electrode edge may be arranged to follow a portion of one of the pair of side edges of the second elongate member.

[0038] The intermediate portions of the elongate members may be angularly arranged with respect to one another about an axis when the structure is in the deployed configuration. At least some of the plurality of electrodes may be radially spaced about the axis when the structure is in the deployed configuration. At least some of the plurality of electrodes may be circumferentially arranged about the axis when the structure is in the deployed configuration. The intermediate portion of the first elongate member may cross the intermediate portion of the second elongate member at a location on the structure intersected by the axis when the structure is in the deployed configuration. The intermediate portion of the first elongate member may be adjacent the intermediate portion of the second elongate member when the structure is in the deployed configuration. A particular one of the plurality of electrodes may be intersected by the axis when the structure is in the deployed configuration. The one or more electrodes may include a first electrode, the first electrode located on the structure adjacent the particular one of the plurality of electrodes when the structure is in the deployed configuration. The one or more electrodes may include a first electrode, and at least some of the plurality of electrodes may be arranged in a plurality of concentric ringed arrangements when the structure is in the deployed configuration. In some embodiments, a first one of the plurality of concentric ringed arrangements has a fewer number of the electrodes than a second one of the plurality of concentric ringed arrangements. The first one of the plurality of concentric ringed arrangements may include the first electrode.

[0039] A portion of the first side edge of the first elongate member extending between the first location and the second location may form a recessed portion of the first elongate member that exposes at least a portion of a particular electrode of the one or more electrodes as viewed normally to a surface of the exposed portion of the particular electrode of the one or more electrodes when the structure is in the deployed configuration.

[0040] Each of the plurality of elongate members may be arranged to be advanced distal end-first into the bodily cavity when the structure is in the delivery configuration. The respective intermediate portions of the plurality of elongate members may be arranged front surface-toward-back surface in a stacked array when the structure is in the delivery configuration. The structure may further include a proximal portion and a distal portion, each of the proximal and the distal portions including a respective part of each of the plurality of elongate members. In some embodiments, the proximal portion of the structure forms a first domed shape and the distal portion of the structure forms a second domed shape when the structure is in the deployed configuration.

[0041] The structure may include a proximal portion and a distal portion, with the structure arranged to be advanced distal portion first into the bodily cavity when the structure is in the delivery configuration. In some embodiments, the proximal portion of the structure forms a first domed shape and the distal portion of the structure forms a second domed shape when the structure is in the deployed configuration, the proximal and the distal portions of the structure arranged in a clam shell configuration when the structure is in the deployed configuration.

[0042] Various systems may include combinations and subsets of all the systems summarized above.

BRIEF DESCRIPTION OF THE DRAWINGS

[0043] It is to be understood that the attached drawings are for purposes of illustrating aspects of various embodiments and may include elements that are not to scale.

[0044] FIG. 1 is a schematic representation of a transducer-activation system according to example embodiments, the transducer-activation system including a data processing device system, an input-output device system, and a memory device system.

[0045] FIG. 2 is a cutaway diagram of a heart showing a transducer-based device percutaneously placed in a left atrium of the heart according to example embodiments.

[0046] FIG. 3A is a partially schematic representation of a medical device system according to example embodiments, the medical device system including a data processing device system, an input-output device system, a memory device system, and a transducer-based device having a plurality of transducers and an expandable structure shown in a delivery or unexpanded configuration.

[0047] FIG. 3B is the medical device system of FIG. 3A with the expandable structure shown in a deployed or expanded configuration.

[0048] FIG. 3C is a representation of the expandable structure of the medical device system of FIG. 3A in the deployed configuration, as viewed from a different viewing angle than that employed in FIG. 3B.

[0049] FIG. 3D is a plan view of the expandable structure of FIG. 3C.

[0050] FIG. 3E is an enlarged view of a portion of the expandable structure of FIG. 3D.

[0051] FIG. 3F is a representation of an expandable structure of a transducer-based device system according to various example embodiments, the expandable structure in a deployed configuration.

[0052] FIG. 3G is a plan view of the expandable structure of FIG. 3F.

[0053] FIG. 3H is a perspective view of two of the elongate members of the expandable structure of FIGS. 3F and 3G, each of the elongate members shown in a flattened configuration.

[0054] FIG. 3I is an enlarged view of a portion of the expandable structure of FIG. 3G.

[0055] FIG. 3J is a plan view of the expandable structure of FIG. 3F with an elongate member of the structure omitted for clarity.

[0056] FIG. 3K is a perspective view of two elongate members of an expandable structure of a transducer-based device system according to various embodiments, each of the elongate members shown in a flattened configuration.

[0057] FIG. 4 is a schematic representation of a transducer-based device that includes a flexible circuit structure according to at least one example embodiment.

DETAILED DESCRIPTION

[0058] In the following description, certain specific details are set forth in order to provide a thorough understanding of various embodiments of the invention. However, one skilled in the art will understand that the invention may be practiced without one or more of these details. In other instances, well-known structures (e.g., structures associated with radio-frequency (RF) ablation and electronic controls such as multiplexers) have not been shown or described in detail

to avoid unnecessarily obscuring descriptions of various embodiments of the invention.

[0059] Reference throughout this specification to “one embodiment” or “an embodiment” or “an example embodiment” or “an illustrated embodiment” or “a particular embodiment” and the like means that a particular feature, structure or characteristic described in connection with the embodiment is included in at least one embodiment. Thus, the appearances of the phrases “in one embodiment” or “in an embodiment” or “in an example embodiment” or “in this illustrated embodiment” or “in this particular embodiment” and the like in various places throughout this specification are not necessarily all referring to the same embodiment. Furthermore, the particular features, structures or characteristics of different embodiments may be combined in any suitable manner to form one or more other embodiments.

[0060] It is noted that, unless otherwise explicitly noted or required by context, the word “or” is used in this disclosure in a non-exclusive sense. In addition, unless otherwise explicitly noted or required by context, the word “set” is intended to mean one or more.

[0061] Further, the phrase “at least” is used herein at times to emphasize the possibility that other elements can exist besides those explicitly listed. However, unless otherwise explicitly noted (such as by the use of the term “only”) or required by context, non-usage herein of the phrase “at least” does not exclude the possibility that other elements can exist besides those explicitly listed. For example, the phrase, “activation of at least transducer A” includes activation of transducer A by itself, as well as activation of transducer A and activation of one or more other additional elements besides transducer A. In the same manner, the phrase, “activation of transducer A” includes activation of transducer A by itself, as well as activation of transducer A and activation of one or more other additional elements besides transducer A. However, the phrase, “activation of only transducer A” includes only activation of transducer A, and excludes activation of any other elements besides transducer A.

[0062] The word “ablation” as used in this disclosure should be understood to include any disruption to certain properties of tissue. Most commonly, the disruption is to the electrical conductivity and is achieved by heating, which can be generated with resistive or radio-frequency (RF) techniques for example. Other properties, such as mechanical or chemical, and other means of disruption, such as optical, are included when the term “ablation” is used.

[0063] The word “fluid” as used in this disclosure should be understood to include any fluid that can be contained within a bodily cavity or can flow into or out of, or both into and out of a bodily cavity via one or more bodily openings positioned in fluid communication with the bodily cavity. In the case of cardiac applications, fluid such as blood will flow into and out of various intra-cardiac cavities (e.g., a left atrium or right atrium).

[0064] The words “bodily opening” as used in this disclosure should be understood to include a naturally occurring bodily opening or channel or lumen; a bodily opening or channel or lumen formed by an instrument or tool using techniques that can include, but are not limited to, mechanical, thermal, electrical, chemical, and exposure or illumination techniques; a bodily opening or channel or lumen formed by trauma to a body; or various combinations of one or more of the above. Various elements having respective

openings, lumens or channels and positioned within the bodily opening (e.g., a catheter sheath or catheter introducer) may be present in various embodiments. These elements may provide a passageway through a bodily opening for various devices employed in various embodiments.

[0065] The words “bodily cavity” as used in this disclosure should be understood to mean a cavity in a body. The bodily cavity may be a cavity provided in a bodily organ (e.g., an intra-cardiac cavity of a heart).

[0066] The word “tissue” as used in some embodiments in this disclosure should be understood to include any surface-forming tissue that is used to form a surface of a body or a surface within a bodily cavity, a surface of an anatomical feature or a surface of a feature associated with a bodily opening positioned in fluid communication with the bodily cavity. The tissue can include part or all of a tissue wall or membrane that defines a surface of the bodily cavity. In this regard, the tissue can form an interior surface of the cavity that surrounds a fluid within the cavity. In the case of cardiac applications, tissue can include tissue used to form an interior surface of an intra-cardiac cavity such as a left atrium or right atrium. In some embodiments, the word tissue can refer to a tissue having fluidic properties (e.g., blood).

[0067] The term “transducer” as used in this disclosure should be interpreted broadly as any device capable of distinguishing between fluid and tissue, sensing temperature, creating heat, ablating tissue, measuring electrical activity of a tissue surface, stimulating tissue, or any combination thereof. A transducer can convert input energy of one form into output energy of another form. Without limitation, a transducer can include an electrode that functions as, or as part of, a sensing device included in the transducer, an energy delivery device included in the transducer, or both a sensing device and an energy delivery device included in the transducer. A transducer may be constructed from several parts, which may be discrete components or may be integrally formed.

[0068] The term “activation” as used in this disclosure should be interpreted broadly as making active a particular function as related to various transducers disclosed in this disclosure. Particular functions can include, but are not limited to, tissue ablation, sensing electrophysiological activity, sensing temperature and sensing electrical characteristics (e.g., tissue impedance). For example, in some embodiments, activation of a tissue ablation function of a particular transducer is initiated by causing energy sufficient for tissue ablation from an energy source device system to be delivered to the particular transducer. Alternatively, in this example, the activation can be deemed to be initiated when the particular transducer causes a temperature sufficient for the tissue ablation due to the energy provided by the energy source device system. Also in this example, the activation can last for a duration of time concluding when the ablation function is no longer active, such as when energy sufficient for the tissue ablation is no longer provided to the particular transducer. Alternatively, in this example, the activation period can be deemed to be concluded when the temperature caused by the particular transducer is below the temperature sufficient for the tissue ablation. In some contexts, however, the word “activation” can merely refer to the initiation of the activating of a particular function, as opposed to referring to both the initiation of the activating of the particular function and the subsequent duration in which

the particular function is active. In these contexts, the phrase or a phrase similar to “activation initiation” may be used.

[0069] The term “program” in this disclosure should be interpreted as a set of instructions or modules that can be executed by one or more components in a system, such as a controller system or data processing device system, in order to cause the system to perform one or more operations. The set of instructions or modules can be stored by any kind of memory device, such as those described subsequently with respect to the memory device system **130** shown in FIG. **1**. In addition, instructions or modules of a program may be described as being configured to cause the performance of a function. The phrase “configured to” in this context is intended to include at least (a) instructions or modules that are presently in a form executable by one or more data processing devices to cause performance of the function (e.g., in the case where the instructions or modules are in a compiled and unencrypted form ready for execution), and (b) instructions or modules that are presently in a form not executable by the one or more data processing devices, but could be translated into the form executable by the one or more data processing devices to cause performance of the function (e.g., in the case where the instructions or modules are encrypted in a non-executable manner, but through performance of a decryption process, would be translated into a form ready for execution). The word “module” can be defined as a set of instructions.

[0070] The word “device” and the phrase “device system” both are intended to include one or more physical devices or subdevices (e.g., pieces of equipment) that interact to perform one or more functions, regardless of whether such devices or subdevices are located within a same housing or different housings. In this regard, for example, the phrase “catheter device” could equivalently be referred to as a “catheter device system”.

[0071] In some contexts, the term “adjacent” is used in this disclosure to refer to objects that do not have another substantially similar object between them. For example, object A and object B could be considered adjacent if they contact each other (and, thus, it could be considered that no other object is between them), or if they do not contact each other, but no other object that is substantially similar to object A, object B, or both objects A and B, depending on context, is between them.

[0072] Further, the phrase “in response to” might be used in the following context, where an event A occurs in response to the occurrence of an event B. In this regard, such phrase can include, for example, that at least the occurrence of the event B causes or triggers the event A.

[0073] FIG. **1** schematically illustrates a system **100** for activating transducers, according to some embodiments. The system **100** includes a data processing device system **110**, an input-output device system **120**, and a processor-accessible memory device system **130**. The processor-accessible memory device system **130** and the input-output device system **120** are communicatively connected to the data processing device system **110**.

[0074] The data processing device system **110** includes one or more data processing devices that implement methods by controlling or interacting with various structural components described herein, including, but not limited to, various structural components illustrated in the other FIGS. **2-4**. Each of the phrases “data processing device”, “data processor”, “processor”, and “computer” is intended to

include any data processing device, such as a central processing unit (“CPU”), a desktop computer, a laptop computer, a mainframe computer, a tablet computer, a personal digital assistant, a cellular phone, and any other device for processing data, managing data, or handling data, whether implemented with electrical, magnetic, optical, biological components, or otherwise.

[0075] The memory device system 130 includes one or more processor-accessible memory devices configured to store information, including the information needed to execute the methods implemented by the data processing device system 110. The memory device system 130 may be a distributed processor-accessible memory device system including multiple processor-accessible memory devices communicatively connected to the data processing device system 110 via a plurality of computers and/or devices. On the other hand, the memory device system 130 need not be a distributed processor-accessible memory system and, consequently, may include one or more processor-accessible memory devices located within a single housing or data processing device.

[0076] Each of the phrases “processor-accessible memory” and “processor-accessible memory device” is intended to include any processor-accessible data storage device, whether volatile or nonvolatile, electronic, magnetic, optical, or otherwise, including but not limited to, registers, floppy disks, hard disks, Compact Discs, DVDs, flash memories, ROMs, and RAMs. In some embodiments, each of the phrases “processor-accessible memory” and “processor-accessible memory device” is intended to include a non-transitory computer-readable storage medium. And in some embodiments, the memory device system 130 can be considered a non-transitory computer-readable storage medium system.

[0077] The phrase “communicatively connected” is intended to include any type of connection, whether wired or wireless, between devices, data processors, or programs in which data may be communicated. Further, the phrase “communicatively connected” is intended to include a connection between devices or programs within a single data processor, a connection between devices or programs located in different data processors, and a connection between devices not located in data processors at all. In this regard, although the memory device system 130 is shown separately from the data processing device system 110 and the input-output device system 120, one skilled in the art will appreciate that the memory device system 130 may be located completely or partially within the data processing device system 110 or the input-output device system 120. Further in this regard, although the input-output device system 120 is shown separately from the data processing device system 110 and the memory device system 130, one skilled in the art will appreciate that such system may be located completely or partially within the data processing device system 110 or the memory device system 130, depending upon the contents of the input-output device system 120. Further still, the data processing device system 110, the input-output device system 120, and the memory device system 130 may be located entirely within the same device or housing or may be separately located, but communicatively connected, among different devices or housings. In the case where the data processing device system 110, the input-output device system 120, and the memory device system 130 are located within the same device, the system

100 of FIG. 1 can be implemented by a single application-specific integrated circuit (ASIC) in some embodiments.

[0078] The input-output device system 120 may include a mouse, a keyboard, a touch screen, another computer, or any device or combination of devices from which a desired selection, desired information, instructions, or any other data is input to the data processing device system 110. The input-output device system may include a user-activatable control system that is responsive to a user action. The input-output device system 120 may include any suitable interface for receiving information, instructions or any data from other devices and systems described in various ones of the embodiments. In this regard, the input-output device system 120 may include various ones of other systems described in various embodiments. For example, the input-output device system 120 may include at least a portion of a transducer-based device system. The phrase “transducer-based device system” is intended to include one or more physical systems that include one or more physical devices that include transducers.

[0079] The input-output device system 120 also may include an image generating device system, a display device system, a processor-accessible memory device, or any device or combination of devices to which information, instructions, or any other data is output by the data processing device system 110. In this regard, if the input-output device system 120 includes a processor-accessible memory device, such memory device may or may not form part or all of the memory device system 130. The input-output device system 120 may include any suitable interface for outputting information, instructions or data to other devices and systems described in various ones of the embodiments. In this regard, the input-output device system may include various other devices or systems described in various embodiments. For example, the input-output device system may include a portion of a transducer-based device system.

[0080] Various embodiments of transducer-based devices are described herein. Some of the described devices are medical devices that are percutaneously or intravascularly deployed. Some of the described devices are moveable between a delivery or unexpanded configuration in which a portion of the device is sized for passage through a bodily opening leading to a bodily cavity, and an expanded or deployed configuration in which the portion of the device has a size too large for passage through the bodily opening leading to the bodily cavity. An example of an expanded or deployed configuration is when the portion of the transducer-based device is in its intended-deployed-operational state inside the bodily cavity. Another example of the expanded or deployed configuration is when the portion of the transducer-based device is being changed from the delivery configuration to the intended-deployed-operational state to a point where the portion of the device now has a size too large for passage through the bodily opening leading to the bodily cavity.

[0081] In some example embodiments, the device includes transducers that sense characteristics (e.g., convective cooling, permittivity, force) that distinguish between fluid, such as a fluidic tissue (e.g., blood), and tissue forming an interior surface of the bodily cavity. Such sensed characteristics can allow a medical device system to map the cavity, for example using positions of openings or ports into and out of the cavity to determine a position or orientation (i.e., pose), or both of the portion of the device in the bodily cavity. In

some example embodiments, the described devices are capable of ablating tissue in a desired pattern within the bodily cavity. In some example embodiments, the devices are capable of sensing characteristics (e.g., electrophysiological activity) indicative of whether an ablation has been successful. In some example embodiments, the devices are capable of providing stimulation (e.g., electrical stimulation) to tissue within the bodily cavity. Electrical stimulation may include pacing.

[0082] FIG. 2 shows a transducer-based device 200, which may be all or part of a medical device system, useful in investigating or treating a bodily organ, for example a heart 202, according to some example embodiments.

[0083] Transducer-based device 200 can be percutaneously or intravascularly inserted into a portion of the heart 202, such as an intra-cardiac cavity like left atrium 204. In this example, the transducer-based device 200 is part of a catheter 206 inserted via the inferior vena cava 208 and penetrating through a bodily opening in transatrial septum 210 from right atrium 212. In other embodiments, other paths may be taken.

[0084] Catheter 206 includes an elongated flexible rod or shaft member appropriately sized to be delivered percutaneously or intravascularly. Various portions of catheter 206 may be steerable. Catheter 206 may include one or more lumens (not shown). The lumen(s) may carry one or more communications or power paths, or both. For example, the lumens(s) may carry one or more electrical conductors 216 (two shown in this embodiment). Electrical conductors 216 provide electrical connections to device 200 that are accessible externally from a patient in which the transducer-based device 200 is inserted.

[0085] Transducer-based device 200 includes a frame or structure 218 which assumes an unexpanded configuration for delivery to left atrium 204. Structure 218 is expanded (i.e., shown in a deployed or expanded configuration in FIG. 2) upon delivery to left atrium 204 to position a plurality of transducers 220 (three called out in FIG. 2) proximate the interior surface formed by tissue 222 of left atrium 204. In some embodiments, at least some of the transducers 220 are used to sense a physical characteristic of a fluid (i.e., blood) or tissue 222, or both, that may be used to determine a position or orientation (i.e., pose), or both, of a portion of a device 200 within, or with respect to left atrium 204. For example, transducers 220 may be used to determine a location of pulmonary vein ostia (not shown) or a mitral valve 226, or both. In some embodiments, at least some of the transducers 220 may be used to selectively ablate portions of the tissue 222. For example, some of the transducers 220 may be used to ablate a pattern or path around various ones of the bodily openings, ports or pulmonary vein ostia, for instance to reduce or eliminate the occurrence of atrial fibrillation.

[0086] FIGS. 3A, 3B, 3C, 3D and 3E show a transducer-based device system (i.e., a portion thereof shown schematically) that includes a transducer-based device 300 according to one illustrated embodiment. Transducer-based device 300 includes a plurality of elongate members 304 (three called out in each of FIGS. 3A and 3B, and three are called out in each of FIGS. 3C, 3D and 3E as 304a, 304b and 304c) and a plurality of transducers 306 (three called out in FIG. 3A, three called out in FIG. 3B as 306a, 306b and 306c, and seven called out in each of FIGS. 3C and 3D, six of the seven identified as 306q, 306r, 306s, 306t, 306u and 306v). As will

become apparent, the plurality of transducers 306 are positionable within a bodily cavity. For example, in some embodiments, the transducers 306 are able to be positioned in a bodily cavity by movement into, within, or into and within the bodily cavity, with or without a change in a configuration of the plurality of transducers 306. In some embodiments, the plurality of transducers 306 are arrangeable to form a two- or three-dimensional distribution, grid or array of the transducers capable of mapping, ablating or stimulating an inside surface of a bodily cavity or lumen without requiring mechanical scanning. As shown for example, in FIG. 3A, the plurality of transducers 306 are arranged in a distribution receivable in a bodily cavity (not shown in FIG. 3A). As shown for example, in FIG. 3A, the plurality of transducers 306 are arranged in a distribution suitable for delivery to a bodily cavity (not shown in FIG. 3A). (It should also be noted, for example, that the expanded or deployed configuration (e.g., FIGS. 2, 3B-3G, 3I, and 3J) also provide transducers 306 arranged in a distribution receivable in a bodily cavity.)

[0087] The elongate members 304 are arranged in a frame or structure 308 that is selectively movable between an unexpanded or delivery configuration (i.e., as shown in FIG. 3A) and an expanded or deployed configuration (i.e., as shown in FIG. 3B) that may be used to position elongate members 304 against a tissue surface within the bodily cavity or position the elongate members 304 in the vicinity of or in contact with the tissue surface. In some embodiments, structure 308 has a size in the unexpanded or delivery configuration suitable for percutaneous delivery through a bodily opening (i.e., via catheter sheath 312, not shown in FIG. 3B) to the bodily cavity. In some embodiments, structure 308 has a size in the expanded or deployed configuration too large for percutaneous delivery through a bodily opening (i.e., via catheter sheath 312) to the bodily cavity. The elongate members 304 may form part of a flexible circuit structure (i.e., also known as a flexible printed circuit board (PCB) circuit). The elongate members 304 can include a plurality of different material layers, and each of the elongate members 304 can include a plurality of different material layers. The structure 308 can include a shape memory material, for instance Nitinol. The structure 308 can include a metallic material, for instance stainless steel, or non-metallic material, for instance polyimide, or both a metallic and non metallic material by way of non-limiting example. The incorporation of a specific material into structure 308 may be motivated by various factors including the specific requirements of each of the unexpanded or delivery configuration and expanded or deployed configuration, the required position or orientation (i.e., pose) or both of structure 308 in the bodily cavity, or the requirements for successful ablation of a desired pattern.

[0088] FIG. 4 is a schematic side elevation view of at least a portion of a transducer-based device 400 that includes a flexible circuit structure 401 that is employed to provide a plurality of transducers 406 (two called out) according to an example embodiment. In some embodiments, the flexible circuit structure 401 may form part of a structure (e.g., structure 308) that is selectively movable between a delivery configuration sized for percutaneous delivery and expanded or deployed configurations sized too large for percutaneous delivery. In some embodiments, the flexible circuit structure

401 may be located on, or form at least part of, of a structural component (e.g., elongate member **304**) of a transducer-based device system.

[0089] The flexible circuit structure **401** can be formed by various techniques including flexible printed circuit techniques. In some embodiments, the flexible circuit structure **401** includes various layers including flexible layers **403a**, **403b** and **403c** (i.e., collectively flexible layers **403**). In some embodiments, each of flexible layers **403** includes an electrical insulator material (e.g., polyimide). One or more of the flexible layers **403** can include a different material than another of the flexible layers **403**. In some embodiments, the flexible circuit structure **401** includes various electrically conductive layers **404a**, **404b** and **404c** (collectively electrically conductive layers **404**) that are interleaved with the flexible layers **403**. In some embodiments, each of the electrically conductive layers **404** is patterned to form various electrically conductive elements. For example, electrically conductive layer **404a** is patterned to form a respective electrode **415** of each of the transducers **406**. Electrodes **415** have respective electrode edges **415-1** that form a periphery of an electrically conductive surface associated with the respective electrode **415**. FIG. 3C shows another example of electrode edges **315-1** and illustrates that the electrode edges can define electrically-conductive-surface-peripheries of various shapes.

[0090] Returning to FIG. 4, electrically conductive layer **404b** is patterned, in some embodiments, to form respective temperature sensors **408** for each of the transducers **406** as well as various leads **410a** arranged to provide electrical energy to the temperature sensors **408**. In some embodiments, each temperature sensor **408** includes a patterned resistive member **409** (two called out) having a predetermined electrical resistance. In some embodiments, each resistive member **409** includes a metal having relatively high electrical conductivity characteristics (e.g., copper). In some embodiments, electrically conductive layer **404c** is patterned to provide portions of various leads **410b** arranged to provide an electrical communication path to electrodes **415**. In some embodiments, leads **410b** are arranged to pass through vias (not shown) in flexible layers **403a** and **403b** to connect with electrodes **415**. Although FIG. 4 shows flexible layer **403c** as being a bottom-most layer, some embodiments may include one or more additional layers underneath flexible layer **403c**, such as one or more structural layers, such as a steel or composite layer. These one or more structural layers, in some embodiments, are part of the flexible circuit structure **401** and can be part of, e.g., elongate member **304**. In addition, although FIG. 4 shows only three flexible layers **403a-403c** and only three electrically conductive layers **404a-404c**, it should be noted that other numbers of flexible layers, other numbers of electrically conductive layers, or both, can be included.

[0091] In some embodiments, electrodes **415** are employed to selectively deliver RF energy to various tissue structures within a bodily cavity (not shown) (e.g., an intra-cardiac cavity). The energy delivered to the tissue structures may be sufficient for ablating portions of the tissue structures. The energy delivered to the tissue may be delivered to cause monopolar tissue ablation, bipolar tissue ablation or blended monopolar-bipolar tissue ablation by way of non-limiting example. In some embodiments, each electrode **415** is employed to sense an electrical potential in the tissue proximate the electrode **415**. In some embodi-

ments, each electrode **415** is employed in the generation of an intra-cardiac electrogram. In some embodiments, each resistive member **409** is positioned adjacent a respective one of the electrodes **415**. In some embodiments, each of the resistive members **409** is positioned in a stacked or layered array with a respective one of the electrodes **415** to form a respective one of the transducers **406**. In some embodiments, the resistive members **409** are connected in series to allow electrical current to pass through all of the resistive members **409**. In some embodiments, leads **410a** are arranged to allow for a sampling of electrical voltage in between each resistive members **409**. This arrangement allows for the electrical resistance of each resistive member **409** to be accurately measured. The ability to accurately measure the electrical resistance of each resistive member **409** may be motivated by various reasons including determining temperature values at locations at least proximate the resistive member **409** based at least on changes in the resistance caused by convective cooling effects (e.g., as provided by blood flow). In some embodiments in which the transducer-based device is deployed in a bodily cavity (e.g., when the transducer-based device takes the form of a catheter device arranged to be percutaneously or intravascularly delivered to a bodily cavity), it may be desirable to perform various mapping procedures in the bodily cavity. For example, when the bodily cavity is an intra-cardiac cavity, a desired mapping procedure can include mapping electrophysiological activity in the intra-cardiac cavity. Other desired mapping procedures can include mapping of various anatomical features within a bodily cavity. An example of the mapping performed by devices according to various embodiments may include locating the position of the ports of various bodily openings positioned in fluid communication with a bodily cavity. For example, in some embodiments, it may be desired to determine the locations of various ones of the pulmonary veins or the mitral valve that each interrupts an interior surface of an intra-cardiac cavity such as a left atrium.

[0092] In some example embodiments, the mapping is based at least on locating bodily openings by differentiating between fluid and tissue (e.g., tissue defining a surface of a bodily cavity). There are many ways to differentiate tissue from a fluid such as blood or to differentiate tissue from a bodily opening in case a fluid is not present. Four approaches may include by way of non-limiting example:

[0093] 1. The use of convective cooling of heated transducer elements by fluid. An arrangement of slightly heated transducers that is positioned adjacent to the tissue that forms the interior surface(s) of a bodily cavity and across the ports of the bodily cavity will be cooler at the areas which are spanning the ports carrying the flow of fluid.

[0094] 2. The use of tissue impedance measurements. A set of transducers positioned adjacently to tissue that forms the interior surface(s) of a bodily cavity and across the ports of the bodily cavity can be responsive to electrical tissue impedance. Typically, heart tissue will have higher associated tissue impedance values than the impedance values associated with blood.

[0095] 3. The use of the differing change in dielectric constant as a function of frequency between blood and tissue. A set of transducers positioned around the tissue that forms the interior surface(s) of the atrium and across the ports of the atrium monitors the ratio of the dielectric constant from 1 KHz to 100 KHz. Such can be used to

determine which of those transducers are not proximate to tissue, which is indicative of the locations of the ports.

[0096] 4. The use of transducers that sense force (i.e., force sensors). A set of force detection transducers positioned around the tissue that forms the interior surface(s) of a bodily cavity and across the bodily openings or ports of the bodily cavity can be used to determine which of the transducers are not engaged with the tissue, which may be indicative of the locations of the ports.

[0097] Referring to FIGS. 3A, 3B, transducer-based device 300 can communicate with, receive power from or be controlled by a transducer-activation system 322. In some embodiments, elongate members 304 can form a portion of an elongated cable 316 of control leads 317, for example by stacking multiple layers, and terminating at a connector 321 or other interface with transducer-activation system 322. The control leads 317 may correspond to the electrical connectors 216 in FIG. 2 in some embodiments. The transducer-activation device system 322 may include a controller 324 that includes a data processing device system 310 (e.g., from FIG. 1) and a memory device system 330 (e.g., from FIG. 1) that stores data and instructions that are executable by the data processing device system 310 to process information received from transducer-based device 300 or to control operation of transducer-based device 300, for example activating various selected transducers 306 to ablate tissue. Controller 324 may include one or more controllers.

[0098] Transducer-activation device system 322 includes an input-output device system 320 (e.g., an example of 120 from FIG. 1) communicatively connected to the data processing device system 310 (i.e., via controller 324 in some embodiments). Input-output device system 320 may include a user-activatable control that is responsive to a user action. Input-output device system 320 may include one or more user interfaces or input/output (I/O) devices, for example one or more display device systems 332, speaker device systems 334, keyboards, mice, joysticks, track pads, touch screens or other transducers to transfer information to, from, or both to and from a user, for example a care provider such as a physician or technician. For example, output from a mapping process may be displayed on a display device system 332.

[0099] Transducer-activation device system 322 may also include an energy source device system 340 including one or more energy source devices connected to transducers 306. In this regard, although FIG. 3A shows a communicative connection between the energy source device system 340 and the controller 324 (and its data processing device system 310), the energy source device system 340 may also be connected to the transducers 306 via a communicative connection that is independent of the communicative connection with the controller 324 (and its data processing device system 310). For example, the energy source device system 340 may receive control signals via the communicative connection with the controller 324 (and its data processing device system 310), and, in response to such control signals, deliver energy to, receive energy from, or both deliver energy to and receive energy from one or more of the transducers 306 via a communicative connection with such transducers 306 (e.g., via one or more communication lines through catheter body 314, elongated cable 316 or catheter sheath 312) that does not pass through the controller 324. In this regard, the energy source device system 340 may

provide results of its delivering energy to, receiving energy from, or both delivering energy to and receiving energy from one or more of the transducers 306 to the controller 324 (and its data processing device system 310) via the communicative connection between the energy source device system 340 and the controller 324.

[0100] In any event, the number of energy source devices in the energy source device system 340 is fewer than the number of transducers in some embodiments. The energy source device system 340 may, for example, be connected to various selected transducers 306 to selectively provide energy in the form of electrical current or power (e.g., RF energy), light or low temperature fluid to the various selected transducers 306 to cause ablation of tissue. The energy source device system 340 may, for example, selectively provide energy in the form of electrical current to various selected transducers 306 and measure a temperature characteristic, an electrical characteristic, or both at a respective location at least proximate each of the various transducers 306. The energy source device system 340 may include as its energy source devices various electrical current sources or electrical power sources. In some embodiments, an indifferent electrode 326 is provided to receive at least a portion of the energy transmitted by at least some of the transducers 306. Consequently, although not shown in FIG. 3A, the indifferent electrode 326 may be communicatively connected to the energy source device system 340 via one or more communication lines in some embodiments. In addition, although shown separately in FIG. 3A, indifferent electrode 326 may be considered part of the energy source device system 340 in some embodiments.

[0101] It is understood that input-output device system 320 may include other systems. In some embodiments, input-output device system 320 may optionally include energy source device system 340, transducer-based device 300 or both energy source device system 340 and transducer-based device 300 by way of non-limiting example.

[0102] Structure 308 can be delivered and retrieved via a catheter member, for example a catheter sheath 312. In some embodiments, a structure provides expansion and contraction capabilities for a portion of a medical device (e.g., an arrangement, distribution or array of transducers 306). The transducers 306 can form part of, be positioned or located on, mounted or otherwise carried on the structure and the structure may be configurable to be appropriately sized to slide within catheter sheath 312 in order to be deployed percutaneously or intravascularly. FIG. 3A shows one embodiment of such a structure. In some embodiments, each of the elongate members 304 includes a respective distal end 305 (only one called out), a respective proximal end 307 (only one called out) and an intermediate portion 309 (only one called out) positioned between the proximal end 307 and the distal end 305. The respective intermediate portion 309 of each elongate member 304 includes a first or front surface 318a that is positionable to face an interior tissue surface within a bodily cavity (not shown) and a second or back surface 318b opposite across a thickness of the intermediate portion 309 from the front surface 318a. In various embodiments, the intermediate portion 309 of each of the elongate members 304 includes a respective pair of side edges of the front surface 318a, the back surface 318b, or both the front surface 318a and the back surface 318b, the side edges of each pair of side edges opposite to one another, the side edges of each pair of side edges extending between the

proximal end **307** and the distal end **305** of the respective elongate member **304**. In some embodiments, each pair of side edges includes a first side edge **327a** (only one called out in FIG. 3A) and a second side edge **327b** (only one called out in FIG. 3A). In some embodiments, each of the elongate members **304**, including each respective intermediate portion **309**, is arranged front surface **318a**-toward-back surface **318b** in a stacked array during an unexpanded or delivery configuration similar to that described in co-assigned International Application No.: PCT/US2012/022061 and co-assigned International Application No.: PCT/US2012/022062. In many cases a stacked array allows the structure **308** to have a suitable size for percutaneous or intravascular delivery. In some embodiments, the elongate members **304** are arranged to be introduced into a bodily cavity (again not shown in FIG. 3A) distal end **305** first. For clarity, not all of the elongate members **304** of structure **308** are shown in FIG. 3A. A flexible catheter body **314** is used to deliver structure **308** through catheter sheath **312**. In some embodiments, each elongate member includes a twisted portion proximate at proximal end **307**. Similar twisted portions are described in co-assigned International Application No.: PCT/US2012/022061 and co-assigned International Application No.: PCT/US2012/022062.

[0103] In a manner similar to that described in co-assigned International Application No.: PCT/US2012/022061 and co-assigned International Application No.: PCT/US2012/022062, each of the elongate members **304** is arranged in a fanned arrangement **370** in FIG. 3B. In some embodiments, the fanned arrangement **370** is formed during the expanded or deployed configuration in which structure **308** is manipulated to have a size too large for percutaneous or intravascular delivery. In some embodiments, structure **308** includes a proximal portion **308a** having a first domed shape **309a** and a distal portion **308b** having a second domed shape **309b**. In some embodiments, the proximal and the distal portions **308a**, **308b** include respective portions of elongate members **304**. In some embodiments, the structure **308** is arranged to be delivered distal portion **308b** first into a bodily cavity (again not shown) when the structure is in the unexpanded or delivery configuration as shown in FIG. 3A. In some embodiments, the proximal and the distal portions **308a**, **308b** are arranged in a clam shell configuration in the expanded or deployed configuration shown in FIG. 3B. In various example embodiments, each of the front surfaces **318a** (three called out in FIG. 3B) of the intermediate portions **309** of the plurality of elongate members **304** face outwardly from the structure **308** when the structure **308** is in the deployed configuration. In various example embodiments, each of the front surfaces **318a** of the intermediate portions **309** of the plurality of elongate members **304** are positioned adjacent an interior tissue surface of a bodily cavity (not shown) in which the structure **308** (i.e., in the deployed configuration) is located. In various example embodiments, each of the back surfaces **318b** (two called out in FIG. 3B) of the intermediate portions **309** of the plurality of elongate members **304** face an inward direction when the structure **308** is in the deployed configuration.

[0104] The transducers **306** can be arranged in various distributions or arrangements in various embodiments. In some embodiments, various ones of the transducers **306** are spaced apart from one another in a spaced apart distribution in the delivery configuration shown in FIG. 3A. In some embodiments, various ones of the transducers **306** are

arranged in a spaced apart distribution in the deployed configuration shown in FIG. 3B. In some embodiments, various pairs of transducers **306** are spaced apart with respect to one another. In some embodiments, various regions of space are located between various pairs of the transducers **306**. For example, in FIG. 3B the transducer-based device **300** includes at least a first transducer **306a**, a second transducer **306b** and a third transducer **306c** (all collectively referred to as transducers **306**). In some embodiments each of the first, the second, and the third transducers **306a**, **306b** and **306c** are adjacent transducers in the spaced apart distribution. In some embodiments, the first and the second transducers **306a**, **306b** are located on different elongate members **304** while the second and the third transducers **306b**, **306c** are located on a same elongate member **304**. In some embodiments, a first region of space **350** is between the first and the second transducers **306a**, **306b**. In some embodiments, the first region of space **350** is not associated with any physical portion of structure **308**. In some embodiments, a second region of space **360** associated with a physical portion of device **300** (i.e., a portion of an elongate member **304**) is between the second and the third transducers **306b**, **306c**. In some embodiments, each of the first and the second regions of space **350**, **360** does not include a transducer of transducer-based device **300**. In some embodiments, each of the first and the second regions of space **350**, **360** does not include any transducer. It is noted that other embodiments need not employ a group of elongate members **304** as employed in the illustrated embodiment. For example, other embodiments may employ a structure having one or more surfaces, at least a portion of the one or more surfaces defining one or more openings in the structure. In these embodiments, a region of space not associated with any physical portion of the structure may extend over at least part of an opening of the one or more openings. In other example embodiments, other structures may be employed to support or carry transducers of a transducer-based device such as a transducer-based catheter. For example, an elongated catheter member may be used to distribute the transducers in a linear or curvilinear array. Basket catheters or balloon catheters may be used to distribute the transducers in a two-dimensional or three-dimensional array.

[0105] In various example embodiments, at least some of the plurality of transducers **306** include respective electrodes **315** (seven called out in each of FIGS. 3C, 3D, six of the seven called out as **315g**, **315r**, **315s**, **315t**, **315u** and **315v**), each electrode **315** including a respective energy transmission surface **319** (one called out in FIG. 3C, three called out in FIG. 3D, two of the three called out as **319u**, **319v**) configured for transferring energy to tissue, from tissue or both to and from tissue. In various embodiments, each of the energy transmission surfaces **319** is provided by an electrically conductive surface. In some embodiments, each of the electrodes **315** is solely located on a surface of an elongate member **304** (e.g., front surfaces **318a** or back surfaces **318b**). In some embodiments, various electrodes **315** are located on one, but not both of the respective front surface **318a** and respective back surface **318b** of each of various ones of the elongate members **304**.

[0106] Various conventional percutaneous or intravascular transducer-based device systems employ, or have employed, relatively low numbers of transducers typically on the order of 64 or fewer transducers or a number of transducers

arranged with a relatively low spatial distribution density (e.g., a relatively low number of transducers arranged per a given area). Various embodiments disclosed in this detailed description may employ distributions of transducers having relatively high spatial densities (e.g., a relatively high number of transducers arranged per a given region of space) than conventionally employed. Increased number of transducers or increased spatial densities of transducers within a particular distribution of the transducers may be motivated for various reasons. For example, increased numbers of transducers may allow for higher spatial densities in the distributions of the transducers to allow the transducers to interact with a tissue region of a bodily cavity with greater resolution and accuracy. The interactions may include ablation, temperature detection, impedance detection, electrophysiological activity detection and tissue stimulation by way of non-limiting example. In some case, distributions of transducers having relatively high spatial densities may provide enhanced diagnostic or treatment procedures performed on a given tissue region by allowing for the interaction of a greater number of transducers with the given tissue region. Various embodiments disclosed in this detailed description may employ 100 or more transducers, 200 or more transducers or even 300 or more transducers. Various transducer-based devices disclosed in this detailed description (e.g., as depicted at least in part in FIGS. 3A, 3B, 3C, 3D, 3E, 3F, 3G, 3H, 3I, 3J and 3K) are representative of various embodiments that employ several hundreds of transducers. Various transducer-based devices disclosed in this detailed description (e.g., as depicted at least in part in FIGS. 3A, 3B, 3C, 3D, 3E, 3F, 3G, 3H, 3I, 3J and 3K) are representative of various embodiments that employ distributions of transducers having relatively higher spatial densities. Although transducers 306, electrodes 315 or both transducers 306 and electrodes 315 are referenced with respect to various embodiments, it is understood that other transducers or transducer elements may be employed in other embodiments. It is understood that a reference to a particular transducer 306 in various embodiments may also imply a reference to an electrode 315, as an electrode 315 may be part of the transducer 306 as shown, e.g., with FIG. 4.

[0107] FIG. 3C is a perspective view of at least one embodiment of the transducer-based device 300 as viewed from a viewing angle that is different from that shown in FIG. 3B. For clarity of illustration, only structure 308 including various ones of the elongate members 304, and a portion of catheter body 314 are shown in FIG. 3C. In a manner similar to that shown in FIG. 3B, transducer-based device 300 is shown in the expanded or deployed configuration. In some embodiments, the respective intermediate portions 309 (only two called out) of various ones of the elongate members 304 are angularly arranged with respect to one another about a first axis 335a when structure 308 is in the deployed configuration. In various embodiments, the respective intermediate portions 309 of a respective pair of the elongate members 304 are angularly spaced with respect to one another by a respective angle radiating from a point on the first axis 335a when structure 308 is in the deployed configuration. The same may apply for each pair of adjacent elongate members 304 in some embodiments. In various embodiments, the intermediate portions 309 of various ones of the elongate members 304 are radially arranged about first axis 335a when structure 308 is in the deployed configuration. In various embodiments, the intermediate portions 309

of various ones of the elongate members 304 are circumferentially arranged about first axis 335a when structure 308 is in the deployed configuration, similar to lines of longitude about an axis of rotation of a body of revolution, which body of revolution may, or may not be spherical. Use of the word circumference in this detailed description, and derivatives thereof, such as circumferential, circumscribe, circumlocutory and other derivatives, refers to a boundary line of a shape, volume or object which may, or may not, be circular or spherical. In some embodiments, each of the elongate members 304 includes a curved portion 323 (only two called out) having a curvature configured to cause the curved portion 323 to extend along at least a portion of a curved path, the curvature configured to cause the curved path to intersect the first axis 335a at each of a respective at least two spaced apart locations along the first axis 335a when structure 308 is in the deployed configuration. In some embodiments, the curved path is defined to include an imagined extension of the curved portion along the curved portion's extension direction while maintaining the curved portion's curvature. In some embodiments, each curved portion 323 may extend entirely along, or at least part way along the respective curved path to physically intersect at least one of the respective at least two spaced apart locations along the first axis 335a. In some particular embodiments, no physical portion of a given elongate member of an employed structure intersects any of the at least two spaced apart locations along the first axis 335a intersected by the respective curved path associated with the curved portion 323 of the given elongate member. For example, the end portion of the given elongate member may be physically separated from the first axis 335a by hub system (not shown) employed to physically couple or align the elongate member to other elongate members. Additionally or alternatively, a given elongate member may include a recurve portion arranged to physically separate the given elongate member from the first axis 335a. In some embodiments, various ones of the elongate members 304 cross one another at a location on the structure 308 passed through by the first axis 335a when the structure 308 is in the deployed configuration. In various embodiments, the curved path is an arcuate path. In various embodiments, at least the portion of the curved path extended along by corresponding curved portion 323 is arcuate. As used herein, the word "curvature" should be understood to mean a measure or amount of curving. In some embodiments, the word "curvature" is associated with a rate of change of the angle through which the tangent to a curve turns in moving along the curve.

[0108] In some embodiments, the intermediate portion 309 of first elongate member 304a overlaps the intermediate portion 309 of a second elongate member 304b at a location on structure 308 passed through by first axis 335a when structure 308 is in the deployed configuration. In some embodiments, the intermediate portions 309 of the first elongate member 304a and the second elongate member 304b cross at a location on structure 308 passed through, or intersected, by first axis 335a when structure 308 is in the deployed configuration. In some embodiments, the intermediate portion 309 of first elongate member 304a is adjacent the intermediate portion 309 of the second elongate member 304b when structure 308 is in the deployed configuration. In various embodiments, the intermediate portions 309 of at least some of the plurality of elongate members 304 are, when the structure 309 is in the deployed configuration,

sufficiently spaced from the first axis 335a to position each of at least some of the plurality of the electrodes 315 at respective locations suitable for contact with a tissue wall of the bodily cavity (not shown in FIG. 3C).

[0109] In various embodiments, at least some of the transducers 306 are radially spaced about first axis 335a when structure 308 is in the deployed configuration. For example, various ones of the electrodes 315 are radially spaced about first axis 335a in the deployed configuration in at least some of the embodiments associated with various ones of FIGS. 3B, 3C, 3D and 3E. In various embodiments, at least some of the transducers 306 are circumferentially arranged about first axis 335a when structure 308 is in the deployed configuration. For example, various ones of the electrodes 315 are circumferentially arranged about first axis 335a in the deployed configuration in at least some of the embodiments associated with various ones of FIGS. 3B, 3C, 3D and 3E. Various methods may be employed to describe the various spatial relationships of the transducers 306 or electrodes 315 or various sets of transducers 306 or sets of electrodes 315 employed according to various embodiments. For example, in FIGS. 3C and 3D the plurality of the electrodes 315 includes a first group 336a (not called out in FIG. 3E) of the electrodes 315 located on first elongate member 304a and a second group 338a (not called out in FIG. 3E) of the electrodes 315 located on second elongate member 304b. It is understood that although electrodes are referred to in these described embodiments, the same analysis applies to the corresponding transducers in some embodiments. It is understood that although groups of electrodes are referred to in these described embodiments, the plurality of electrodes 315 may form part of a plurality of sets of one or more of the electrodes 315, each respective set of the electrodes 315 located on a respective one of the elongate members 304 in other embodiments. The electrodes 315 of the first group 336a are arranged such that each electrode 315 of the first group 336a is intersected by a first plane 342a having no thickness. The phrase “no thickness” in this and similar contexts means no thickness, practically no thickness, or infinitely small thickness, and excludes perceptibly large thicknesses like thicknesses on the order of a size of an electrode 315. The electrodes 315 of the second group 338a are arranged such that each electrode 315 of the second group 338a is intersected by a second plane 344a having no thickness. For clarity, the intersection of each electrode 315 of the first group 336a by first plane 342a is represented in FIG. 3C by intersection line 345a. For clarity, the intersection of each electrode 315 of the second group 338a by second plane 344a is represented in FIG. 3C by intersection line 345b. First plane 342a and second plane 344a are depicted as having boundaries merely for purposes of clarity of illustration in FIG. 3C.

[0110] Each of the first plane 342a and the second plane 344a are non-parallel planes that intersect each other along a second axis 337a. In some embodiments, second axis 337a is parallel to first axis 335a. In some embodiments, first axis 335a and second axis 337a are collinear. In some embodiments, the first axis 335a and the second axis 337a form a single axis. In other embodiments, different spatial relationships may exist between first axis 335a and second axis 337a. In some embodiments, the electrodes 315 are arranged in a spatial distribution in which a first electrode 315q associated with transducer 306q is intersected by each of the first plane 342a and the second plane 344a when the

structure 308 is in the deployed configuration. In some embodiments, first electrode 315q is not intersected by first axis 335a when structure 308 is in the deployed configuration. In some embodiments, first electrode 315q is not intersected by second axis 337a when structure 308 is in the deployed configuration. In some embodiments, the first group 336a of electrodes 315 includes first electrode 315q. In some embodiments, the second group of electrodes 338a does not include first electrode 315q. In various embodiments, the first axis 335a, the second axis 337a or each of the first axis 335a and the second axis 337a intersects at least one electrode 315 located on structure 308 (e.g., electrode 315r associated with transducer 306r in FIGS. 3C and 3D) that does not include first electrode 315q. In some embodiments, the first axis 335a, the second axis 337a or each of the first axis 335a and the second axis 337a does not intersect any electrode 315 located on structure 308, such as, for example, when no polar electrode (e.g., 315r in FIGS. 3C and 3D) is provided. In some embodiments, the first axis 335a, the second axis 337a or each of the first axis 335a and the second axis 337a does not intersect any electrode or transducer.

[0111] FIG. 3D is a plan view of structure 308 in the deployed configuration of FIG. 3C.

[0112] The plan view of FIG. 3D has an orientation such that each of first plane 342a and second plane 344a is viewed ‘on edge’ to their respective planar surfaces. (Note that in embodiments where each of the first plane 342a and the second plane 344a have no thickness, ‘on edge’ is intended to refer to an ‘on edge’ perspective assuming that each plane had an edge of minimal thickness.) The plan view of FIG. 3D has an orientation such that each of the first axis 335a and second axis 337a is viewed along the axis in this particular embodiment. Each of first plane 342a and second plane 344a are represented by a respective “heavier” line in FIG. 3D. Each of first axis 335a and second axis 337a are represented by a “•” symbol in FIG. 3D. It is understood that each of the depicted lines or symbols “•” used to represent any corresponding plane, intersection line or axis in this disclosure do not impart any size attributes on the corresponding plane or axis.

[0113] In various embodiments, each of the first group 336a and the second group 338a includes two or more of the electrodes 315. In some embodiments, the first group 336a, the second group 338a or each of both the first group 336a and the second group 338a includes three or more of the electrodes 315. In various embodiments, the first group 336a, the second group 338a or each of both the first group 336a and the second group 338a includes a pair of adjacent electrodes 315 located on a respective one of the first elongate member 304a and the second elongate member 304b. In some of these various embodiments, a region of space associated with a physical portion of structure 308 (e.g., an elongate member 304 portion) is located between the respective electrodes 315 of the pair of adjacent electrodes 315 included in the first group 336a, and the region of space is intersected by the first plane 342a when the structure 308 is in the deployed configuration. In some embodiments, the respective electrodes 315 of the first group 336a are spaced along a length of a portion of the first elongate member 304a, the length extending between the respective distal and proximal ends 305, 307 (not called out in FIGS. 3B, 3C, 3D and 3E) of the first elongate member 304a, the entirety of the length of the portion of the first

elongate member **304a** being intersected by the first plane **342a** when structure **308** is in the deployed configuration. In some embodiments, the first plane **342a** intersects every electrode **315** located on the first elongate member **304a** when structure **308** is in the deployed configuration. In some embodiments, the second plane **344a** intersects every electrode **315** that is located on the second elongate member **304b** when structure **308** is in the deployed configuration. In some embodiments, some, but not all of the respective electrodes **315** located on the first elongate member **304a**, the second elongate member **304b**, or each of the first elongate member **304a** and the second elongate member **304b** are intersected by a corresponding one of the first plane **342a** and the second plane **344a** when structure **308** is in the deployed configuration.

[0114] In some embodiments, the second axis **337a** is not collinear with the first axis **335a**. In some embodiments, the second axis **337a** and the first axis **335a** do not form a single axis. In some embodiments, the second axis **337a** does not intersect the first axis **335a**. FIG. 3D shows another embodiment in which each electrode **315** of second group **338b** (not called out in FIGS. 3C and 3E) of electrodes **315** located on second elongate member **304b** is intersected by a second plane **344b** having no thickness. Second plane **344b** is viewed transversely to its planar surface in FIG. 3D and is represented by a line. Although second plane **344b** is depicted parallel to second plane **344a** in FIG. 3D, different orientations may be employed in other embodiments. First plane **342a** and second plane **344b** are non parallel planes that intersect one another along a second axis **337b** represented by a symbol “•” in FIG. 3D. For clarity, each of second plane **344b** and second axis **337b** is not shown in FIG. 3C. In at least one particular embodiment associated with FIG. 3D, each of the first plane **342a** and the second plane **344b** intersects a first electrode **315s** associated with transducer **306s** that is not intersected by the second axis **337b**. In at least one particular embodiment associated with FIG. 3D, first electrode **315s** is not intersected by the first axis **335a**. In at least one particular embodiment associated with FIG. 3D, first electrode **315s** is not intersected by the second axis **337b**. In at least one particular embodiment associated with FIG. 3D, second axis **337b** intersects at least one other electrode (e.g., electrode **315t** associated with transducer **306t**). In at least one particular embodiment associated with FIG. 3D, the intermediate portion **309** of the first elongate member **304a** overlaps the intermediate portion **309** of the second elongate member **304b** at each of a first location on structure **308** passed through by first axis **335a** and a second location on structure **308** passed through by the second axis **337b** when structure **308** is in the deployed configuration, the second and first locations being different locations.

[0115] In various embodiments, particular spatial distributions of electrodes or transducers similar to the ones employed in FIGS. 3A, 3B, 3C, 3D and 3E may advantageously allow for higher spatial densities of the electrodes or transducers to be employed. For example, as best seen in FIGS. 3C and 3D, various distributions of electrodes **315** having relatively high spatial densities are created throughout a significant portion of structure **308** including various regions proximate first axis **335a**. It is noted that portions of various ones of elongate members **304** shown in FIGS. 3C and 3D overlap one another as the portions approach first axis **335a** when structure **308** is in the deployed configura-

tion. In various embodiments, overlapping elongate members **304** may be employed at least in part to provide to distributions of the electrodes **315** having higher spatial densities. In FIGS. 3C and 3D, a portion of a first elongate member **304** (e.g., elongate member **304a**) is shown overlapping a portion of at least a second elongate member **304** (e.g., elongate member **304b**) when structure **308** is in the deployed configuration. FIG. 3E includes an enlarged view of a portion of the structure **308** depicted in FIG. 3D, the portion of structure **308** including portions of at least elongate members **304a** and **304b**. For clarity of illustration, planes **342a**, **344a**, **344b** and axis **337b** are not shown in FIG. 3E. In at least one particular embodiment associated with FIG. 3E, a portion **346a** (i.e., only called out in FIG. 3E) of the front surface of **318a** of first elongate member **304a** overlaps a portion **347a** (i.e., only called out in FIG. 3E, partially bounded by a ghosted line **345a** for clarity) of the front surface **318a** of second elongate member **304b** as viewed normally to the portion **346a** of the front surface **318a** of first elongate member **304a** when structure **308** is in the deployed configuration. In this particular embodiment, the spatial density of the distribution of transducers **306**/electrodes **315** is such that at least a first electrode (e.g., electrode **315q** associated with transducer **306q**) is located at least on the portion **346a** of the front surface **318a** of first elongate member **304a**. In some embodiments, the portion of **347a** of the front surface **318a** of second elongate member **304b** faces the back surface **318b** (not called out in FIG. 3E) of first elongate member **304a** when structure **308** is in the deployed configuration. In some embodiments, the portion of **347a** of the front surface **318a** of second elongate member **304b** faces the back surface **318b** of first elongate member **304a** when structure **308** is in the delivery configuration (e.g., when the elongate members **304** are arranged front surface-toward-back surface in a stacked array (e.g., when the structure **308** is in a delivery configuration similar to that depicted in FIG. 3A). In some example embodiments, the portion **347a** of the front surface **318a** of second elongate member **304b** contacts the back surface **318b** of first elongate member **304a** when structure **308** is in the deployed configuration. In a similar manner, a portion **346b** (i.e., only called out in FIG. 3E) of the front surface of **318a** of elongate member **304b** overlaps a portion **347b** (i.e., only called out in FIG. 3E, partially bounded by a ghosted line **345b** for clarity) of the front surface **318a** of elongate member **304c** as viewed normally to the portion **346b** of the front surface **318a** of elongate member **304b** when structure **308** is in the deployed configuration. In this case, a first electrode (e.g., electrode **316u** associated with transducer **306u**) is located at least on the portion **346b** of the front surface **318a** of elongate member **304b**.

[0116] Other spatial characteristics are associated with the distribution of transducers **306**/electrodes **315** associated with various embodiments associated with FIGS. 3A, 3B, 3C, 3D and 3E. For example, as best seen in FIG. 3E, a first side edge **327a** of the first elongate member **304a** crosses a first side edge **327a** of the pair of side edges of the second elongate member **304b** at a first location **351a** and crosses a second side edge **327b** of the pair of side edges of the second elongate member **304b** at a second location **352a** when structure **308** is in the deployed configuration. In various embodiments associated with FIG. 3E, various electrodes **315** are located at least on a portion **348a** of the second elongate member **304b**, the portion **348a** of the second

elongate member **304b** located between a first transverse line **349a** and a second transverse line **349b** (e.g., each depicted by a ghosted line in FIG. 3E) when the structure **308** is in the deployed configuration. In various embodiments associated with FIG. 3E, the first transverse line **349a** extends across a first width **353a** of the second elongate member **304b** at the first location **351a**, and the second transverse line **349b** extends across a second width **353b** of the second elongate member **304b** at the second location **352a**. In at least one particular embodiment associated with FIG. 3E, the first width **353a** and the second width **353b** are the widths of the front surfaces **318a** of the second elongate member **304b**. In at least one particular embodiment associated with FIG. 3E, a magnitude of first width **353a** is substantially the same as a magnitude of the second width **353b**. In some embodiments, the magnitude of the first width **353a** is different than the magnitude of the second width **353b**. In some embodiments, the first transverse line **349a** is perpendicular to one or both of the side edges **327a**, **327b** of the second elongate member **304b**. Similarly, in some embodiments, the second transverse line **349b** is perpendicular to one or both of the side edges **327a**, **327b** of the second elongate member **304b**. In some embodiments, the magnitude of the first width **353a** is a minimum with respect to all other respective magnitudes of possible widths between side edges **327a**, **327b** of the second elongate member **304b** originating at location **351a**. Similarly, in some embodiments, the magnitude of the second width **353b** is a minimum with respect to all other respective magnitudes of possible widths between side edges **327a**, **327b** of the second elongate member **304b** originating at location **352a**.

[0117] In some example embodiments, one or more of the electrodes **315** are wholly located on the portion **348a** of the second elongate member **304b** when the structure **308** is in the deployed configuration. For example, electrode **315u** is wholly located on the portion **348a** (which is rectangular in some embodiments such as FIG. 3E) of the second elongate member **304b** when the structure **308** is in the deployed configuration. In some example embodiments, at least a portion of an electrode **315** of the plurality of electrodes **315** is located on the portion **348a** of the second elongate member **304b** when structure **308** is in the deployed configuration. As shown, for example, in FIG. 3E, electrode **315v** is located at least on portion **348a** in the deployed configuration. In various other embodiments, two or more of the electrodes **315** may be located on the portion **348a** of the second elongate member **304b**.

[0118] It may be noted that distances between adjacent ones of the elongate members **304** shown in FIGS. 3C, 3D and 3E vary as elongate members **304** extend towards first axis **335a** when structure **308** is in the deployed configuration. In some cases, the varying distances between adjacent elongate members **304** in the deployed configuration may give rise to shape, size or dimensional constraints for the electrodes **315** located on the elongate members **304**. In some cases, the overlapping portions of various ones of the elongate members **304** in the deployed configuration may give rise to shape, size or dimensional constraints for the electrodes **315** located on the portions of the various ones of the elongate members **304**. For example, it may be desirable to reduce a surface area of an electrode adjacent an overlap region on an overlapped elongate member to accommodate

the reduced-exposed-surface area of the overlapped elongate member in the region adjacent the overlap region (e.g., electrode **315u** in FIG. 3E).

[0119] In various embodiments, the respective shape of various electrically conductive surfaces (e.g., energy transmission surfaces **319**) of various ones of the electrodes **315** vary among the electrodes **315**. In various embodiments, the respective shape of various electrically conductive surfaces (e.g., energy transmission surfaces **319**) of various ones of the electrodes **315** vary among the electrodes **315** in accordance with their proximity to first axis **335a**. In various embodiments, one or more dimensions or sizes of various electrically conductive surfaces (e.g., energy transmission surfaces **319**) of various ones of the electrodes **315** vary among the electrodes **315**. In various embodiments, one or more dimensional sizes of various electrically conductive surfaces (e.g., energy transmission surfaces **319**) of various ones of the electrodes **315** vary in accordance with their proximity to first axis **335a**. The shape or size variances associated with various ones of the electrodes **315** may be motivated for various reasons. For example, in various embodiments, the shapes or sizes of various ones of the electrodes **315** may be controlled in response to various ones of the aforementioned size or dimensional constraints.

[0120] Referring to FIG. 3E, it is noted that each of various ones of the electrodes **315** (e.g., electrodes **315u** and **315v**) located at least on second elongate member **304b** have various electrode edges (e.g., **315-1** in FIG. 3C or **415-1** in FIG. 4) that form a periphery of an electrically conductive surface associated with each of the various electrodes **315** (e.g., an energy transmission surface **319**). In at least one particular embodiment associated with FIG. 3E, a first electrode edge **333a** associated with electrode **315u** is arranged to follow a portion of the first side edge **327a** of the first elongate member **304a** between the first location **351a** and the second location **352a** when the structure **308** is an expanded or deployed configuration. In some embodiments, the first electrode edge **333a** of electrode **315u** is arranged to be parallel to the portion of the first side edge **327a** of the first elongate member **304a** between the first location **351a** and the second location **352a** when the structure **308** is in an expanded or deployed configuration. In this particular embodiment, a second electrode edge **333b** forming part of the periphery of electrically conductive surface associated with electrode **315u** is positioned opposite across the electrically conductive surface from the first electrode edge **333a**. In this particular embodiment, the second electrode edge **333b** is arranged to follow a portion of one of the side edges **327** of the second elongate member **304b** (e.g., side edge **327a** of second elongate member **304b**). In this particular embodiment, the second electrode edge **333b** is substantially parallel to the side edge **327a** of second elongate member **304b**.

[0121] FIGS. 3F and 3G respectively show perspective and plan views of a plurality of transducers and electrodes located on a structure **313** (e.g., in a deployed configuration) according to various embodiments. In various embodiments, structure **313** is selectively moveable from a delivery configuration to a deployed configuration in a manner similar to structure **308**. It is noted that structure **313** is depicted in FIGS. 3F and 3G in a similar fashion to depictions of structure **308** in FIGS. 3C and 3D. In some embodiments, distributions of transducers or electrodes similar to those employed by structure **313** are employed by the structure

308 of FIGS. 3A, 3B, 3C, 3D and 3E. For the convenience of discussion, various elements associated with structure **313** will be identified by the respective part numbers of the corresponding elements associated with structure **308**. For example, in reference to FIGS. 3F and 3G and other associated Figures, transducers are referred to as transducers **306**, electrodes are referred to as electrodes **315**, energy transmission surfaces are referred to as energy transmission surfaces **319**, elongate members are referred to as elongate members **304**, et cetera. It is noted that these elements disclosed in FIGS. 3F and 3G and other associated Figures are not limited to the embodiments of corresponding elements disclosed in FIGS. 3A, 3B, 3C, 3D and 3E. In some embodiments, structure **313** may assume a delivery configuration similar to that shown for structure **308** in FIG. 3A.

[0122] It may be noted that although the distributions of transducers **306**/electrodes **315** associated with structure **313** have differences from the distribution of transducers **306**/electrodes **315** associated with structure **308**, there are also similarities. The respective intermediate portions **309** of various ones of the elongate members **304** (five called out in each of FIGS. 3F and 3G, four of the five called out as **304d**, **304e**, **304f** and **304g**) are angularly spaced with respect to one another about a first axis **335b** when structure **313** is in the deployed configuration in a manner similar to that previously described with respect to structure **308**. Various ones of the elongate members **304** cross one another at a location on the structure **313** passed through by first axis **335b** when the structure **313** is in the deployed configuration. In at least one particular embodiment associated with FIGS. 3F, 3G, the intermediate portion **309** of a first elongate member (e.g., elongate member **304d**) overlaps the intermediate portion **309** of a second elongate member (e.g., elongate member **304e**) at a location on structure **313** passed through by first axis **335b** when structure **313** is in the deployed configuration. In at least one particular embodiment associated with FIGS. 3F, 3G, the intermediate portion **309** of first elongate member **304d** is adjacent the intermediate portion **309** of the second elongate member **304e** when structure **313** is in the deployed configuration. The transducers **306** (nine called out in each of FIGS. 3F and 3G, eight of the nine called as transducers **306w**, **306x**, **306y**, **306z**, **306aa**, **306bb**, **306cc**, and **306dd**) and electrodes **315** (nine called out in each of FIGS. 3F and 3G, eight of the nine called out as electrodes **315w**, **315x**, **315y**, **315z**, **315aa**, **315bb**, **315cc** and **315dd**) are radially spaced about first axis **335b** when structure **313** is in the deployed configuration in a manner similar to the embodiments associated with structure **308**. The plurality of electrodes **315** located on structure **313** includes a first group **336b** (not called out in FIGS. 3H, 3I) of the electrodes **315** located on first elongate member **304d** and a second group **338c** (not called out in FIGS. 3H, 3I) of the electrodes **315** located on second elongate member **304e**. It is understood that although electrodes are herein described, other forms of transducers or transducer elements may be employed in other embodiments. The electrodes **315** of the first group **336b** are arranged such that each electrode **315** of the first group **336b** is intersected by a first plane **342b** having no thickness. The electrodes **315** of the second group **338c** are arranged such that each electrode **315** of the second group **338c** is intersected by a second plane **344c** having no thickness. For clarity, the intersection of each electrode **315** of the first group **336b** by first plane **342b** is represented in FIG. 3F by intersection line **345c**. For clarity, the intersec-

tion of each electrode **315** of the second group **338c** by second plane **344c** is represented in FIG. 3F by intersection line **345d**. First plane **342b** and second plane **344c** are depicted as having boundaries for clarity of illustration in FIG. 3F.

[0123] Each of the first plane **342b** and the second plane **344c** are non-parallel planes that intersect each other along a second axis **337c** (represented by a symbol “•” in FIG. 3G). In some embodiments, second axis **337c** is parallel to first axis **335b**. In some embodiments, first axis **335b** and second axis **337c** are collinear. In some embodiments, the first axis **335b** and the second axis **337c** form a single axis. In some embodiments, the electrodes **315** are arranged in a spatial distribution in which a first electrode **315** (e.g., electrode **315w** associated with transducer **306w**) is intersected by each of the first plane **342b** and the second plane **344c** when the structure **313** is in the deployed configuration. In at least one particular embodiment, first electrode **315w** is not intersected by first axis **335b** when structure **313** is in the deployed configuration. In at least one particular embodiment, first electrode **315w** is not intersected by second axis **337c** when structure **313** is in the deployed configuration. In at least one particular embodiment, the first group **336b** of electrodes **315** includes first electrode **315w**. In at least one particular embodiment, the second group of electrodes **338c** does not include first electrode **315w**. In various embodiments, the first axis **335a**, the second axis **337c** or each of the first axis **335** and the second axis **337c** intersects at least one other electrode **315** located on structure **313** (e.g., electrode **315x** associated with transducer **306x** in FIGS. 3F, 3G and 3I). In some embodiments, the first axis **335b**, the second axis **337c** or each of the first axis **335b** and the second axis **337c** do not intersect any electrode **315** located on structure **313**.

[0124] In some embodiments, the second axis **337c** is not collinear with the first axis **335b**. In some embodiments, the second axis **337c** and the first axis **335b** do not form a single axis. In some embodiments, the second axis **337c** does not intersect the first axis **335b**. FIG. 3G shows another embodiment in which each electrode **315** of second group **338d** (not called out in FIGS. 3F, 3H and 3I) of electrodes **315** located on a second elongate member **304f** is intersected by a second plane **344d** having no thickness when structure **313** is in a deployed configuration. Second plane **344d** is viewed transversely to its planar surface in FIG. 3G and is represented by a line. For clarity, second plane **344d** is not shown in FIG. 3F. First plane **342b** and second plane **344d** are non parallel planes that intersect one another along a second axis **337d** represented by a symbol “•” in FIG. 3G. In at least one particular embodiment, each of the first plane **342b** and the second plane **344d** intersects a first electrode **315y** associated with transducer **306y** when structure **313** is in a deployed configuration. In at least one particular embodiment, first electrode **315y** is not intersected by the first axis **335b** when structure **313** is in a deployed configuration. In at least one particular embodiment, first electrode **315y** is not intersected by the second axis **337d** when structure **313** is in a deployed configuration. In at least one particular embodiment, second axis **337d** intersects at least one other electrode (e.g., electrode **315z** associated with transducer **306z**) when structure **313** is in a deployed configuration.

[0125] Embodiments associated with FIGS. 3F and 3G have spatial distributions of the transducers **306**/electrodes **315** that have relatively high spatial densities in various

regions of structure 313 including a plurality of regions proximate first axis 335*b*. In various embodiments, a spatial distribution of the transducers 306/electrodes 315 in various regions proximate first axis 335*b* have higher spatial densities than similar distributions associated with various embodiments of FIGS. 3A, 3B, 3C, 3D and 3E. Embodiments associated with FIGS. 3F and 3G may provide for electrodes 315 having electrically conductive surfaces (e.g., energy transmission surfaces 319, three called out in each of FIGS. 3F and 3G, two of the three called out as 319*c* and 319*d*) of greater size or dimension than some of the electrodes 315 associated with various embodiments of FIGS. 3A, 3B, 3C, 3D and 3E. In particular, larger electrodes 315 may be provided in regions proximate first axis 335*b* in at least some of the embodiments associated with FIGS. 3F and 3G. The use of larger electrodes (e.g., larger electrically conductive surfaces such as energy transmission surfaces 319*c* and 319*d*) may be motivated for various reasons. For example, in some tissue ablation applications, tissue ablation depths may be dependent on the size of the electrodes 315 employed for the ablation, with a use of larger electrodes 315 typically reaching a particular ablation depth in a shorter activation time than a use of relatively smaller electrodes 315. In some tissue ablation applications, deeper tissue ablation depths may be associated with larger electrodes.

[0126] FIG. 3H shows perspective views of each of first elongate member 304*d* and second elongate member 304*e* in a “flattened” configuration in which the curved form of these elongate members 304 in FIGS. 3F and 3G is flattened out. It is noted that in embodiments where the elongate members 304 in FIGS. 3F and 3G include a twisted portion similar to the twisted portions of various ones of the elongate members 304 associated with FIGS. 3A, 3B, 3C, 3D and 3E, the twisted portions are shown untwisted in the flattened configuration of FIG. 3H. The flattened configuration is presented for clarity of illustration and it is understood that in the deployed configuration, FIGS. 3F and 3G are better representative of the forms of various ones of the elongate members at least in the deployed configuration. In a manner similar to the elongate members 304 of structure 308, the intermediate portion 309 of each of the elongate members 304*d*, 304*e* includes a front surface 318*a* and back surface 318*b* opposite across a thickness 318*c* of the elongate member. In some embodiments, at least some of the transducers 306/electrodes 315 are located on the front surfaces 318*a*. Each intermediate portion 309 includes a respective pair of side edges 327*a*, 327*b*. In various embodiments, the side edges 327*a*, 327*b* of each intermediate portion 309 are respective side edges of the front surface 318*a*, the back surface 318*b*, or both the front surface 318*a* and the back surface 318*b* of the intermediate portion 309. Each of the pair of side edges 327*a*, 327*b* extends between the proximal end 307 and the distal end 305 of the elongate member 304.

[0127] In some embodiments associated with FIGS. 3F and 3G, various ones of elongate members overlap one another when structure 313 is in the deployed configuration. In various embodiments, overlapping elongate members 304 may be employed at least in part to provide to distributions of the electrodes 315 having higher spatial densities. FIG. 3I includes an enlarged view of a portion of the structure 313 depicted in FIG. 3G, the portion of structure 313 including portions of at least elongate members 304*d* and 304*e*. For clarity of illustration, planes 342*b*, 344*c*, 344*d* and axis 337*d* are not shown in FIG. 3I.

[0128] In at least one particular embodiment, various portions of the front surface 318*a* of the first elongate member 304*d* overlap various portions of the front surface 318*a* of each of several ones of the plurality of elongate members 304 when structure 313 is in the deployed configuration. In at least one particular embodiment, various portions of the front surface 318*a* of the first elongate member 304*d* overlap various portions of the front surface 318*a* of every other one of the plurality of elongate members 304 when structure 313 is in the deployed configuration. In at least one particular embodiment associated with FIG. 3I, a portion 346*c* (i.e., only called out in FIG. 3I) of the front surface of 318*a* of a first elongate member 304 (e.g., elongate member 304*d*) overlaps a portion 347*c* (i.e., only called out in FIG. 3I, partially bounded by a ghosted line 345*c*) of the front surface 318*a* of at least a second elongate member (e.g., elongate member 304*e*) as viewed normally to the portion 346*a* of the front surface 318*a* of first elongate member 304*a* when structure 313 is in the deployed configuration. In at least one particular embodiment, the spatial density of the distribution of transducers 306/electrodes 315 is such that at least a first electrode (e.g., first electrode 315*w* associated with transducer 306*w*) is located at least on the portion 346*c* of the front surface 318*a* of first elongate member 304*d*. In at least one particular embodiment, the portion of 347*c* of the front surface 318*a* of second elongate member 304*e* faces the back surface 318*b* (not called out in FIG. 3I) of first elongate member 304*d* when structure 313 is in the deployed configuration. In some embodiments, the portion of 347*c* of the front surface 318*a* of second elongate member 304*e* faces the back surface 318*b* of first elongate member 304*d* when structure 313 is in the delivery configuration (e.g., when the elongate members 304 are arranged front surface-toward-back surface in a stacked array when the structure 313 is in a delivery configuration similar to that depicted in FIG. 3A). In some example embodiments, the portion of 347*c* of the front surface 318*a* of second elongate member 304*e* contacts the back surface 318*b* of first elongate member 304*d* when structure 313 is in the deployed configuration.

[0129] In FIGS. 3F, 3G and 3I, the first elongate member 304*d* is positioned such that first edge 327*a* of the first elongate member 304*d* crosses at least a second edge of the second elongate member 304*e* (e.g., second edge 327*b* of second elongate member 304*e*) when structure 313 is in the deployed configuration. In some of the embodiments associated with FIGS. 3F, 3G, 3H and 3I a portion of the first edge 327*a* of the first elongate member 304*d* forms a recessed portion 328*a* of first elongate member 304*d* that exposes at least a portion of a second transducer 306*aa* (e.g., second electrode 315*aa* in at least one particular embodiment) located on second elongate member 304*e*. All recessed portions such as recessed portion 328*a* described herein are collectively referred to as recessed portions 328. In at least some of the embodiments associated with FIGS. 3F, 3G, 3H and 3I, the exposed portion of second transducer 306*aa* (e.g., electrode 315*aa*) is located at least on portion of a surface (e.g., front surface 318*a*) of the second elongate member 304*e* as viewed normally to the portion of the surface of the second elongate member 304*e* when structure 313 is in the deployed configuration. In at least some of the embodiments associated with FIGS. 3F, 3G, 3H and 3I, recessed portion 328*a* of first elongate member 304*d* exposes at least a portion of second electrode 315*aa* as

viewed normally to a surface of the exposed portion of second electrode **315aa**. In at least some of the example embodiments associated with FIGS. **3F**, **3G**, **3H** and **3I**, the exposed portion of second transducer **306aa** (e.g., electrode **315aa**) is located on the second elongate member **304e** as viewed towards the second transducer **306aa** along a direction parallel to a direction that the first axis **335b** extends along when structure **313** is in the deployed configuration. In some embodiments, the second group **338c** includes second transducer **306aa** (e.g., electrode **315aa**). As best shown in FIGS. **3G** and **3I**, in some embodiments, the second transducer **306aa** (e.g., electrode **315aa**) is adjacent first transducer **306w** (e.g., electrode **315w**) when structure **313** is in the deployed configuration. In various embodiments associated with FIGS. **3F**, **3G**, **3H** and **3I**, at least some of the plurality of transducers **306**/electrodes **315** are arranged in a plurality of concentric ringed arrangements **329** (four called out in FIG. **3G** (one of which is shown by a ghosted line), two of the four called out as **329a**, **329b**) about the first axis **335b** when structure **313** is in the deployed configuration, a first one of the ringed arrangements **329** (e.g., ringed arrangement **329a**) having a fewer number of the transducers **306** (e.g., electrodes **315**) than a second one of the ringed arrangements (e.g., ringed arrangement **329b**). In some of these various example embodiments, the first ringed arrangement includes first transducer **306w** (e.g., electrode **315w**). In some of these various embodiments, the first ringed arrangement **329a** does not include any of the transducers **306** (e.g., electrodes **315**) located on the second elongate member **304e**. In some of these example embodiments, the second ringed arrangement **329b** includes the second transducer **306aa**. In some of these various embodiments, the first ringed arrangement **329a** is adjacent the second ringed arrangement **329b**.

[0130] In various embodiments, first elongate member **304d** includes a second recessed portion **328b** (called out in FIGS. **3F**, **3G** and **3H**) arranged to expose a portion of at least one transducer (e.g., electrode **315bb** associated with transducer **306bb**) located on second elongate member **304e** when structure **313** is in the deployed configuration. In various embodiments, second elongate member **304e** includes several recessed portions (e.g., recessed portions **328c** and **328d** called out in FIGS. **3H**, **3J**). In at least one particular embodiment, each of the recessed portions **328c** and **328d** has different dimensions or sizes than each of recessed portions **328a** and **328b**. Differences in the dimensions or sizes of various ones of the recessed portions **328** (e.g., any of recessed portions **328a**, **328b**, **328c**, **328d** and other described recessed portions) may be motivated by various reasons including the location of their corresponding elongate member **304** in structure **313** or a spatial relationship between various ones of the transducers **306**/electrodes **315** in the deployed configuration. In some embodiments, the differences in the sizes or dimensions of various ones of the recessed portions **328** may be employed to create distribution of transducers **306**/electrodes **315** having higher spatial densities. In various embodiments, each recessed portion **328c**, **328d** is arranged to expose a portion of at least one transducer **306** (e.g., electrode **315cc** associated with transducer **306cc** and electrode **315dd** associated with transducer **306dd**) located on elongate member **304g** when structure **313** is in the deployed configuration. This is best shown in FIG. **3J** which shows a plan view of structure **313** in the deployed configuration similar to that shown in FIG. **3G**

with the exception that elongate member **304d** is not shown. It is understood that elongate member **304d** is not shown in FIG. **3J** only to better show elongate member **304e** and its associated recessed portions **328c** and **328d**. For clarity of illustration, planes **342b**, **344c**, **344d** and axes **335b**, **337c**, **337d** are not shown in FIG. **3J**.

[0131] In various embodiments associated with FIG. **3J**, a first side edge **327a** of a first elongate member (e.g., elongate member **304e**) crosses a first side edge **327a** of the pair of side edges of a second elongate member (e.g., elongate member **304g**) at a first location **351b** and crosses a second side edge **327b** of the pair of side edges of the second elongate member **304g** at a second location **352b** when structure **313** is in the deployed configuration. In various embodiments associated with FIG. **3J**, various electrodes **315** are located at least on a portion **348b** of the second elongate member **304g**, the portion **348b** of the second elongate member **304g** located between a first transverse line **349c** and a second transverse line **349d** (e.g., each depicted by a ghosted line in FIG. **3J**) when the structure **313** is in the deployed configuration. In various embodiments associated with FIG. **3J**, the first transverse line **349c** extends across a first width **353c** of the second elongate member **304g** at the first location **351b** and the second transverse line **349d** extends across a second width **353d** of the second elongate member **304g** at the second location **352b**. In at least one particular embodiment associated with FIG. **3J**, the first width **353c** and the second width **353d** are the widths of the front surfaces **318a** of the second elongate member **304g**. In at least one particular embodiment associated with FIG. **3J**, a magnitude of first width **353c** is substantially the same as a magnitude of the second width **353d**. In some embodiments, a magnitude of the first width **353c** is different than a magnitude of the second width **353d**. In at least one particular embodiment associated with FIG. **3J**, each of electrodes **315cc** associated with transducer **306cc** and electrode **315dd** associated with transducer **306dd** is wholly located on the portion **348b** of the second elongate member **304g** when the structure **313** is in the deployed configuration. In at least one particular embodiment associated with FIG. **3J**, electrode **315ee** associated with transducer **306ee** is located at least on portion **348b** in the deployed configuration. Similar arrangements exist between other sets of the elongate members **304** of structure **313** in the deployed configuration. For example, referring to FIG. **3I**, a first elongate member (e.g., elongate member **304d**) is positioned such that its first edge **327a** crosses a first side edge **327a** of a second elongate member (elongate member **304e**) at a first location **351c** and crosses a second side edge **327b** of the second elongate member **304e** at a second location **352c** when the structure **313** is in the deployed configuration. Electrode **306aa** associated with transducer **306aa** is wholly located on a portion **348c** of the second elongate member **304e**, the portion **348c** located between a first transverse line **349e** and a second transverse line **349f** when the structure **313** is in the deployed configuration. The first transverse line **349e** extends across a first width **353e** of the second elongate member **304e** at the first location **351c**, and the second transverse line **349f** extends across a second width **353f** of the second elongate member **304e** at the second location **352c**. In this particular embodiment, the first width **353e** is smaller than the second width **353f**.

[0132] In a manner similar to embodiments associated with FIGS. **3A**, **3B**, **3C**, **3D** and **3E**, electrically conductive

surfaces (e.g., energy transmission surfaces 319) of various ones of the electrodes 315 employed in various embodiments associated with FIGS. 3F, 3G, 3H, 3I, and 3J may have different sizes or shapes. For example, referring to FIG. 3J, it is noted that each of various one of the electrodes 315 (e.g., electrodes 315cc, 315dd and 315ee) located on at least one elongate member 304g have different shapes and sizes. In at least one particular embodiment associated with FIG. 3J, a periphery of an electrically conductive surface (e.g., an energy transmission surface 319) of various ones of the electrodes 315 is defined by various electrode edges. For example, electrode 315dd includes a first electrode edge 333c and a second electrode edge 333d opposite across an electrically conductive surface of electrode 315dd from the first electrode edge 333c. In at least one particular embodiment, the first electrode edge 333c associated with electrode 315dd is arranged to follow a portion of the first side edge 327a of the overlapping elongate member 304e between the first location 351b and the second location 352b when the structure 313 is in an expanded or deployed configuration. In at least one particular embodiment, the first electrode edge 333c of electrode 315dd is arranged to be parallel to the portion of the first side edge 327a of the overlapping elongate member 304e between the first location 351b and the second location 352b when the structure 313 is in an expanded or deployed configuration. In at least one particular embodiment, the first electrode edge 333c of electrode 315dd is arranged to follow a portion of the first side edge 327a that defines or forms part of, the recessed portion 328c of overlapping elongate member 304e in the expanded or deployed configuration. In at least one particular embodiment, the second electrode edge 333d associated with electrode 315dd is arranged to follow a portion of one of the side edges 327 of elongate member 304g (e.g., side edge 327a of second elongate member 304g). In at least one particular embodiment, the second electrode edge 333d associated with electrode 315dd is arranged to follow a portion of one of the side edges 327 of elongate member 304g (e.g., side edge 327a of second elongate member 304g) that defines, or forms part of, a recessed portion 328j of the elongate member 304g. In at least one particular embodiment, a first part of a first electrode edge 333e associated with electrode 315ee located on elongate member 304g is arranged to follow a portion of the first side edge 327a that defines, or forms part of, the recessed portion 328c of overlapping elongate member 304e when structure 313 is in the deployed configuration, and a second part of the first electrode edge 333e of electrode 315ee is arranged to follow a portion of the first side edge 327a that does not define or form part of the recessed portion 328c of overlapping elongate member 304e when structure 313 is in an expanded or deployed configuration. In at least one particular embodiment, a first part of a second electrode edge 333f associated with electrode 315ee is arranged to follow a portion of the first side edge 327a that defines, or forms part of, the recessed portion 328j of the elongate member 304g, and a second part of the second electrode edge 333f is arranged to follow a portion of the first side edge 327a of elongate member 304j that does not define, or form part of, the recessed portion 328j.

[0133] In at least one particular embodiment associated with FIGS. 3F, 3G, 3H, and 3I, the edge 327a of the first elongate member 304d is interrupted by a notch 330a. Similarly, in some embodiments, the edge 327a of the first elongate member 304d is interrupted by recessed portion

328a of the first elongate member 304d. In some embodiments, the recessed portion 328a forms at least a portion of the notch 330a. In this particular illustrated embodiment, notch 330a is located in the intermediate portion 309 of the first elongate member 304d and extends towards the second edge 327b. In a similar fashion, the recessed portions 328b, 328c and 328d may form a portion of a respective one of notches 330b, 330c and 330d (called out in FIG. 3H) in various embodiments. In various embodiments associated with FIGS. 3F, 3G, 3H, 3I and 3J, various ones of the recessed portions 328 may be advantageously employed to create, at least in part, a spatial distribution of the transducers 315 having a relatively high spatial density. In various embodiments associated with FIGS. 3F, 3G, 3H, 3I and 3J, various ones of recessed portions 328 may be advantageously employed to address, at least in part, transducer size or shape constraints associated with structure 313 (e.g., overlapping regions of elongate members 304 or varying distances between various elongate members 304). In various embodiments associated with FIGS. 3F, 3G, 3H, 3I and 3J, various ones of recessed portions 328 may allow, at least in part, for the use of electrodes 315 having relatively large electrically conductive surfaces (e.g., energy transmission surfaces 319). Other benefits may accompany the use of recessed portions such as recessed portions 328. For example, in some embodiments, recessed portions similar to various ones of recess portions 328 may be employed to increase fluid flow (e.g., blood flow) in a particular region of structure 313 (e.g., a region where elongate members 304 overlap one another) that may hinder or otherwise obstruct a flow of fluid (e.g., blood flow).

[0134] In other embodiments, various ones of the recessed portions 328 may take a form other than a notch (e.g., notch 330a). For example, FIG. 3K includes a perspective view of two elongate members 304h and 304i in a flattened configuration similar to that shown by elongate members 304d and 304e in FIG. 3H. Elongate members 304h and 304i are similar to elongate members 304d and 304e in various embodiments, form part of structure of a transducer-based device system (not shown) similar to structures 308, 313. In some of these various embodiments, the structure may be configurable between a delivery configuration and a deployed configuration similar to that previously described in this detailed description. In some of these various embodiments, elongate member 304h overlaps elongate member 304i when the structure is the deployed configuration in a manner similar to elongate members 304d and 304e. For convenience of discussion, various elements of each of elongate members 304h and 304i are identified by the same part numbers employed to identify similar elements in other previously described elongate members. In some embodiments, each of elongate members 304h and 304i includes an intermediate portion 309 that includes a front surface 318a and back surface 318b opposite across a thickness 318c of the elongate member. In some embodiments, at least some of the transducers 306/electrodes 315 are located on the front surfaces 318a. Each intermediate portion 309 includes a respective pair of side edges 327a, 327b extending between proximal and distal ends 307, 305 of the elongate member 304. In a manner similar to that shown in FIGS. 3F, 3G, and 3I the first elongate member 304h may be positioned such that first edge 327a of the first elongate member 304h crosses a second edge 327b of the second elongate member 304i when the associated structure is in the deployed con-

figuration. In a manner similar to elongate members 304d, 304e, each of the elongate members 304h, 304i includes a set of recessed portions 328 (e.g., associated ones of recessed portions 328e, 328f, 328g, 328h). In some embodiments, each of the elongate members 304h, 304i includes a jogged portion (e.g., a respective one of jogged portions 331a, 331b), each jogged portion undergoing at least one change in direction as the jogged portion extends between the proximal and distal ends 307, 305 of the respective elongate member. In various embodiments, various ones of the recessed portions 328e, 328f, 328g and 328h may form a part of one of the jogged portions 331a, 331b. In various embodiments, various ones of the recessed portions 328e, 328f, 328g and 328h may be located on respective ones of the elongate members 304h and 304i to expose a portion of at least one transducer 306/electrode 315 located on another elongate member 304 (e.g., when an associated structure that includes the elongate members 304 is in a deployed configuration). In other example embodiments, a surface of a particular one of the elongate members may be interrupted by a channel (e.g., trough, groove, aperture), the channel located to expose a portion of at least one transducer 306/electrode 315 located on another elongate member 304 especially when an associated structure that includes the elongate members 304 is in a deployed configuration.

[0135] While some of the embodiments disclosed above are described with examples of cardiac mapping, the same or similar embodiments may be used for mapping other bodily organs, for example gastric mapping, bladder mapping, arterial mapping and mapping of any lumen or cavity into which the devices of the present invention may be introduced.

[0136] While some of the embodiments disclosed above are described with examples of cardiac ablation, the same or similar embodiments may be used for ablating other bodily organs or any lumen or cavity into which the devices of the present invention may be introduced.

[0137] Subsets or combinations of various embodiments described above can provide further embodiments.

[0138] These and other changes can be made to the invention in light of the above-detailed description. In general, in the following claims, the terms used should not be construed to limit the invention to the specific embodiments disclosed in the specification and the claims, but should be construed to include other transducer-based device systems including all medical treatment device systems and medical diagnostic device systems in accordance with the claims. Accordingly, the invention is not limited by the disclosure, but instead its scope is to be determined entirely by the following claims.

1. (canceled)

2. A medical device system comprising:

a structure; and

a plurality of electrodes positionable in a bodily cavity and supported, by the structure,

wherein the structure is selectively moveable between:

a delivery configuration in which the structure is sized to be percutaneously deliverable to the bodily cavity, and

a deployed configuration in which the structure is sized too large to be percutaneously deliverable to the bodily cavity, and

wherein at least some of the plurality of electrodes are arranged in a plurality of concentric ringed arrange-

ments about an axis of the structure when the structure is in the deployed configuration, a first concentric ringed arrangement of the plurality of concentric ringed arrangements having a fewer number of electrodes than a second concentric ringed arrangement of the plurality of concentric ringed arrangements.

3. The medical device system of claim 2, wherein the first concentric ringed arrangement is positioned radially inward from the second concentric ringed arrangement as viewed along the axis when the structure is in the deployed configuration.

4. The medical device system of claim 2, wherein, when the structure is in the deployed configuration, the axis extends outwardly from a particular location interior the structure toward a region of space outside the structure, and wherein, when the structure is in the deployed configuration, the first concentric ringed arrangement is positioned outwardly farther from the particular location toward the region of space than the second concentric ringed arrangement.

5. The medical device system of claim 2, wherein, when the structure is in the deployed configuration, each electrode in the first concentric ringed arrangement is intersected by a first plane, and each electrode in the second concentric ringed arrangement is intersected by a second plane.

6. The medical device system of claim 5, wherein, when the structure is in the deployed configuration, the first plane is spaced from the second plane along the axis.

7. The medical device system of claim 5, wherein, when the structure is in the deployed configuration, the axis extends outwardly from a particular location interior the structure toward a region of space outside the structure, and wherein, when the structure is in the deployed configuration, the first plane is positioned outwardly farther from the particular location toward the region of space than the second plane.

8. The medical device system of claim 2, wherein the first concentric ringed arrangement comprises a first electrode having a dimension that is different than a corresponding dimension of a second electrode in the second concentric ringed arrangement.

9. The medical device system of claim 2, wherein the first concentric ringed arrangement comprises a first electrode having a different shape than a shape of a second electrode in the second concentric ringed arrangement.

10. The medical device system of claim 9, wherein the shape of the first electrode tapers toward the axis when the structure is in the deployed configuration.

11. The medical device system of claim 10, wherein the shape of the second electrode tapers toward the axis when the structure is in the deployed configuration.

12. The medical device system of claim 2, wherein the structure comprises a plurality of elongate members, each elongate member comprising an elongated portion arranged to extend toward the axis when the structure is in the deployed configuration, and wherein each respective electrode of a group of the plurality of electrodes is located on a respective one of the plurality of elongate members.

13. The medical device system of claim 12, wherein multiple electrodes of the plurality of electrodes are located on each of a set of one or more elongate members of the plurality of elongate members.

14. The medical device system of claim 12, wherein each respective one of the plurality of elongate members comprises a flexible circuit structure including an electrically

insulative flexible layer and a patterned electrically conductive layer supported by the electrically insulative flexible layer, the patterned electrically conductive layer in electrical communication with the respective electrode of the group of the plurality of electrodes to selectively deliver electrical energy thereto.

15. The medical device system of claim 14, wherein the electrical energy is sufficient to ablate tissue.

16. The medical device system of claim 12, wherein the elongated portions of the plurality of elongate members are arranged to meet at the axis when the structure is in the deployed configuration.

17. The medical device system of claim 16, wherein each respective one of the plurality of elongate members comprises a flexible circuit structure including an electrically insulative flexible layer and a patterned electrically conductive layer supported by the electrically insulative flexible layer, the patterned electrically conductive layer in electrical communication with the respective electrode of the group of the plurality of electrodes to selectively deliver electrical energy thereto.

18. The medical device system of claim 17, wherein the electrical energy is sufficient to ablate tissue.

19. The medical device system of claim 13, wherein each of the elongated portions of the plurality of elongate members is arranged to extend along a respective curved path toward the axis when the structure is in the deployed configuration.

20. The medical device system of claim 19, wherein each respective curved path is convex facing outwardly away from the axis when the structure is in the deployed configuration.

21. The medical device system of claim 12, wherein the elongated portions of the plurality of elongate members are arranged to extend like lines of longitude toward the axis when the structure is in the deployed configuration.

22. The medical device system of claim 21, wherein each respective one of the plurality of elongate members comprises a flexible circuit structure including an electrically insulative flexible layer and a patterned electrically conductive layer supported by the electrically insulative flexible layer, the patterned electrically conductive layer in electrical communication with the respective electrode of the group of the plurality of electrodes to selectively deliver electrical energy thereto.

23. The medical device system of claim 22, wherein the electrical energy is sufficient to ablate tissue.

24. The medical device system of claim 2, wherein the structure comprises a plurality of elongate members, each elongate member comprising an elongated portion arranged to extend toward the axis when the structure is in the deployed configuration, a respective group of the plurality of electrodes located on a respective one of at least some of the plurality of elongate members; and each respective one of the at least some of the plurality of elongate members comprises a flexible circuit structure including an electrically insulative flexible layer and a patterned electrically conductive layer supported by the electrically insulative flexible layer, the patterned electrically conductive layer comprising a plurality of leads, each lead in electrical communication with a respective electrode of the respective group of the plurality of electrodes to selectively deliver electrical energy thereto.

25. The medical device system of claim 24, wherein the electrical energy is sufficient to ablate tissue.

26. The medical device system of claim 12, wherein the plurality of elongate members includes a first elongate member and a second elongate member, wherein each of at least a first electrode in the first concentric ringed arrangement and a second electrode in the second concentric ringed arrangement is located on the first elongate member, and wherein the first concentric ringed arrangement does not include any electrode located on the second elongate member.

27. The medical device system of claim 26, wherein the second concentric ringed arrangement includes a third electrode located on the second elongate member.

28. The medical device system of claim 27, wherein the second electrode and the third electrode are circumferentially adjacent in the second concentric ringed arrangement.

29. The medical device system of claim 27, wherein the plurality of elongate members comprises a third elongate member, wherein each of at least a fourth electrode in the first concentric ringed arrangement and a fifth electrode in the second concentric ringed arrangement is located on the third elongate member.

30. The medical device system of claim 29, wherein at least the elongated portion of the second elongate member is located between at least the respective elongated portions of the first elongate member and the third elongate member when the structure is in the deployed configuration.

31. The medical device system of claim 29,

wherein at least the elongated portion of the first elongate member and at least the elongated portion of the second elongate member are adjacent when the structure is in the deployed configuration, and

wherein at least the elongated portion of the second elongate member and at least the elongated portion of the third elongate member are adjacent when the structure is in the deployed configuration.

32. The medical device system of claim 29,

wherein at least the elongated portions of the plurality of elongate members are circumferentially arranged about the axis when the structure is in the deployed configuration, and

wherein at least the elongated portion of the second elongate member is circumferentially between at least the elongated portion of the first elongate member and at least the elongated portion of the third elongate member when the structure is in the deployed configuration.

33. The medical device system of claim 29, wherein the first electrode and the fourth electrode are circumferentially adjacent electrodes in the first concentric ringed arrangement.

34. The medical device system of claim 32, wherein at least a particular portion of the second elongate member is located between the first electrode and the fourth electrode when the structure is in the deployed configuration.

35. The medical device system of claim 32, wherein the second electrode, the third electrode, and the fifth electrode are provided by two pairs of circumferentially adjacent electrodes in the second concentric ringed arrangement.

36. The medical device system of claim 26, wherein each respective one of the plurality of elongate members comprises a flexible circuit structure including an electrically insulative flexible layer and a patterned electrically conduc-

tive layer supported by the electrically insulative flexible layer, the patterned electrically conductive layer in electrical communication with the respective electrode of the group of the plurality of electrodes to selectively deliver electrical energy thereto.

37. The medical device system of claim **36**, wherein the electrical energy is sufficient to ablate tissue.

38. The medical device system of claim **2**, wherein each of the at least some of the plurality of electrodes is selectively activatable to transmit energy sufficient to ablate tissue.

39. A method of operating a medical device system comprising a structure and a plurality of electrodes positionable in a bodily cavity, the plurality of electrodes supported by the structure, the method comprising:

manipulating the structure between a first configuration in which the structure is sized to be percutaneously deliverable to the bodily cavity and a second configuration in which the structure is in a state in which at least some of the plurality of electrodes are arranged in a plurality of concentric ringed arrangements about an axis of the structure, a first concentric ringed arrangement of the plurality of concentric ringed arrangements having a fewer number of electrodes than a second concentric ringed arrangement of the plurality of concentric ringed arrangements.

40. The method of claim **39**, wherein each of the at least some of the plurality of electrodes is selectively activatable to transmit energy sufficient to ablate tissue.

* * * * *

专利名称(译)	基于高密度电极的医疗器械系统		
公开(公告)号	US20170020604A1	公开(公告)日	2017-01-26
申请号	US15/287988	申请日	2016-10-07
[标]申请(专利权)人(译)	卡尔蒂姆公司		
申请(专利权)人(译)	KARDIUM INC.		
当前申请(专利权)人(译)	KARDIUM INC.		
[标]发明人	LOPES FERNANDO LUIS DE SOUZA MOISA SAAR HAWES PETER JOSIAH		
发明人	LOPES, FERNANDO LUIS DE SOUZA MOISA, SAAR HAWES, PETER JOSIAH		
IPC分类号	A61B18/14 A61B5/00 A61B5/04		
CPC分类号	A61B18/1492 A61B5/04 A61B5/6858 A61B2562/0209 A61B2562/04 A61B2018/1475 A61B2018/00208 A61B2018/00267 A61B2018/00357 A61B2018/00577 A61B2018/1417 A61B2018/0016 A61B5/042 A61B5/0422 A61B5/0538 A61B5/6885 A61B2018/1407 A61B2018/1467 A61B2562/0271 A61B2562/046 A61N1/056		
优先权	61/723311 2012-11-06 US 61/670881 2012-07-12 US 61/649734 2012-05-21 US 61/734750 2012-12-07 US 61/435213 2011-01-21 US 61/485987 2011-05-13 US 61/488639 2011-05-20 US 61/515141 2011-08-04 US		
外部链接	Espacenet USPTO		

摘要(译)

公开了一种医疗设备系统，其包括高密度布置的换能器，其可以被配置成消融，刺激或感测身体腔内的组织特征，例如心内腔。特别是考虑到细长构件的重叠，可以至少部分地通过重叠细长构件实现换能器的高密度布置，换能器位于换能器上的细长构件以及换能器的不同尺寸，形状或两者。此外，换能器的高密度布置可以至少部分地通过在细长构件中包括一个或多个凹陷部分来实现，以便在邻近细长构件的区域中暴露下面的细长构件上的一个或多个换能器-重叠区域。

