



US 20150289772A1

(19) **United States**

(12) **Patent Application Publication**
Huang et al.

(10) **Pub. No.: US 2015/0289772 A1**

(43) **Pub. Date: Oct. 15, 2015**

(54) **IMPLANTABLE PRESSURE MONITOR**

Publication Classification

(71) Applicant: **UNIVERSITY OF ROCHESTER,**
Rochester, NY (US)

(51) **Int. Cl.**
A61B 5/022 (2006.01)
A61B 5/0235 (2006.01)
A61B 5/00 (2006.01)
A61B 5/0215 (2006.01)

(72) Inventors: **Jason Haitao Huang,** Temple, TX (US);
Samantha Dayawansa, Temple, TX (US)

(52) **U.S. CL.**
CPC *A61B 5/02241* (2013.01); *A61B 5/02154*
(2013.01); *A61B 5/0235* (2013.01); *A61B*
5/6883 (2013.01)

(73) Assignee: **The University of Rochester,** Rochester, NY (US)

(21) Appl. No.: **14/647,705**

(57) **ABSTRACT**

(22) PCT Filed: **Nov. 25, 2013**

There is provided an implantable pressure monitor having a fluid sack in contact with a body part of a patient where the fluid sack is retained to the body part by a pressure monitor housing that may have various attachment means. The fluid sack is filled with a liquid such as silicone oil. The pressure monitor housing has an opening that provides access to a fistula with a fluid valve that terminates through the fluid sack. A fiber optic pressure sensor is in contact with the liquid in the fluid sack by way of the fistula and fluid valve. In some embodiments of the present invention, an electronics module is incorporated with the implantable pressure monitor to provide telemetry, power, and the like.

(86) PCT No.: **PCT/US13/71757**

§ 371 (c)(1),

(2) Date: **May 27, 2015**

Related U.S. Application Data

(60) Provisional application No. 61/731,742, filed on Nov. 30, 2012.

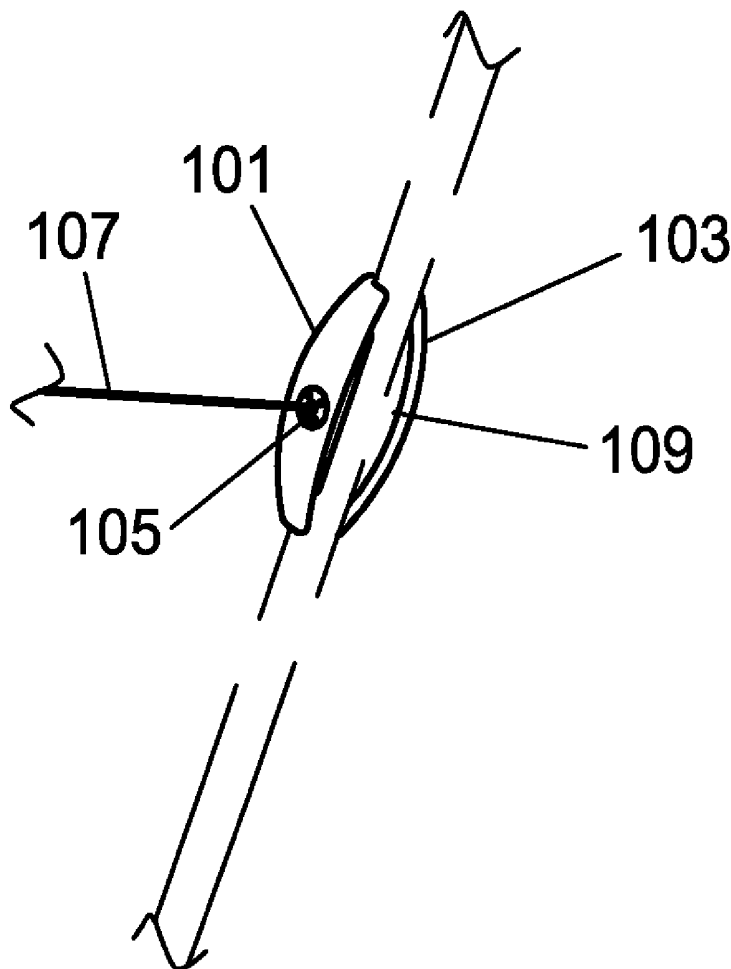

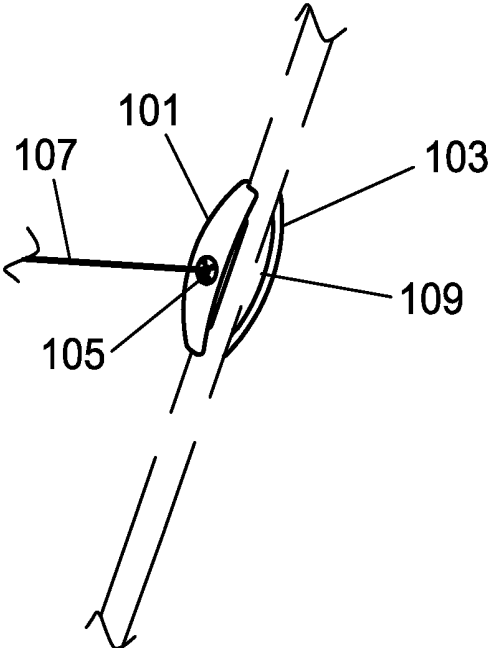

Fig. 1

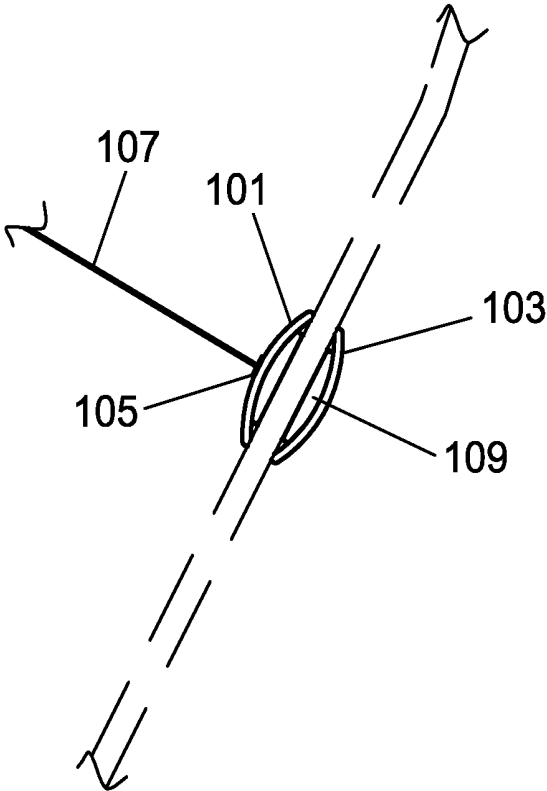

Fig. 2

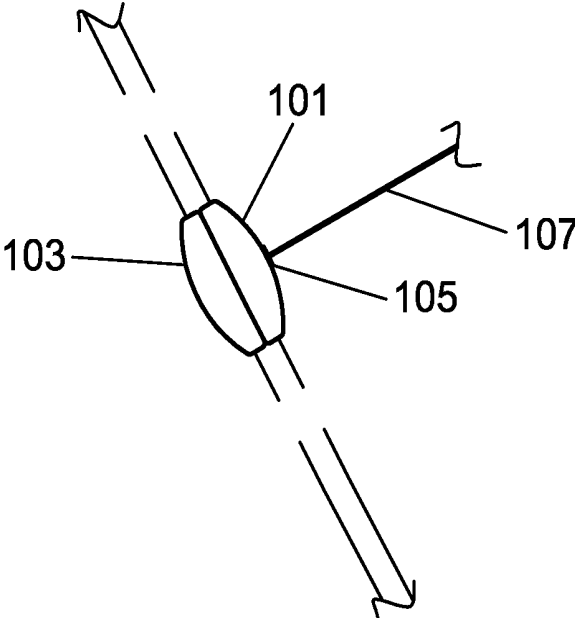

Fig. 3

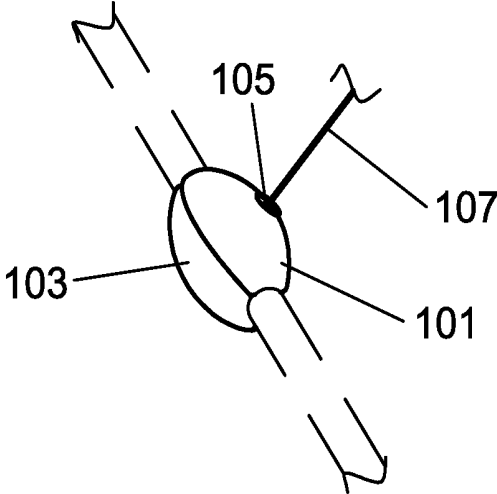

Fig. 4

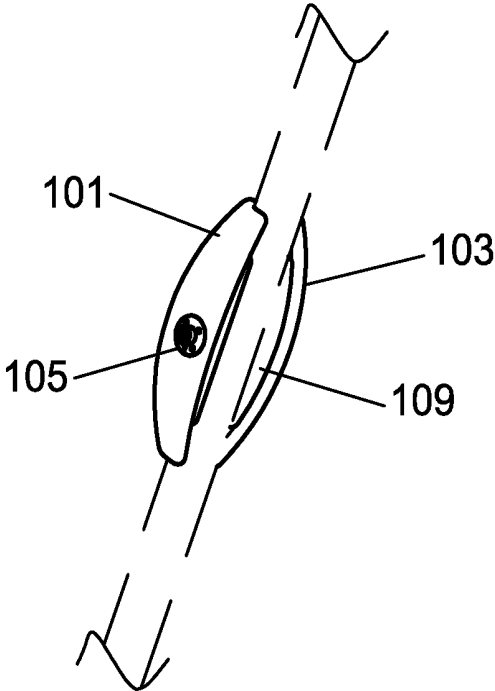

Fig. 5

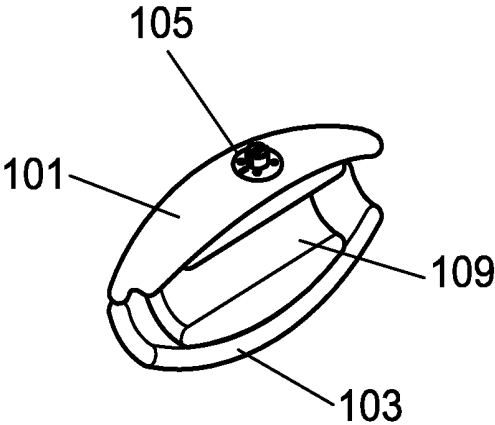

Fig. 6

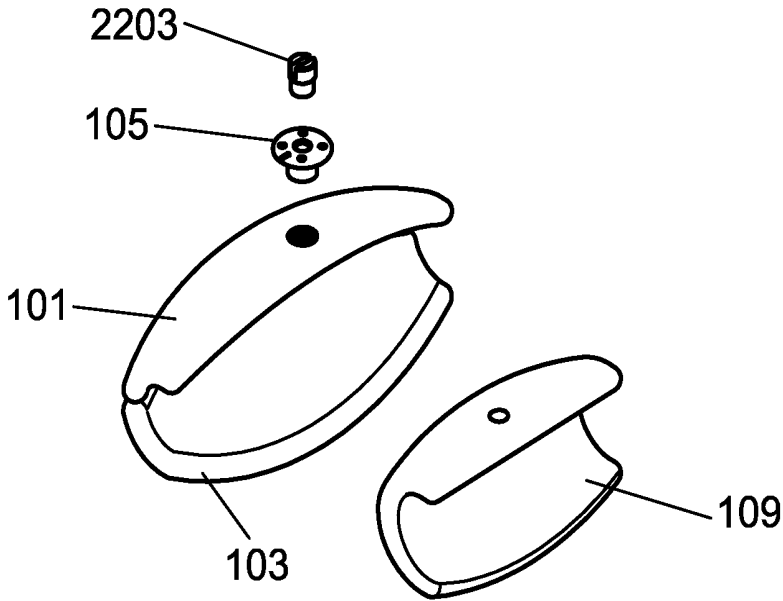

Fig. 7

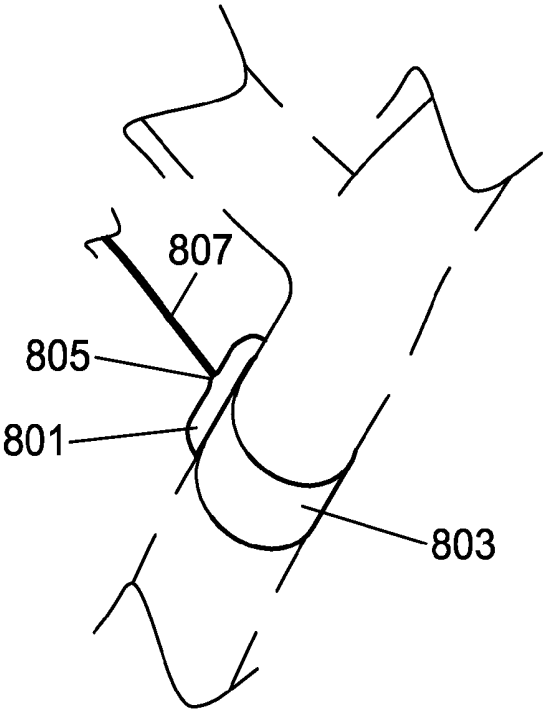

Fig. 8

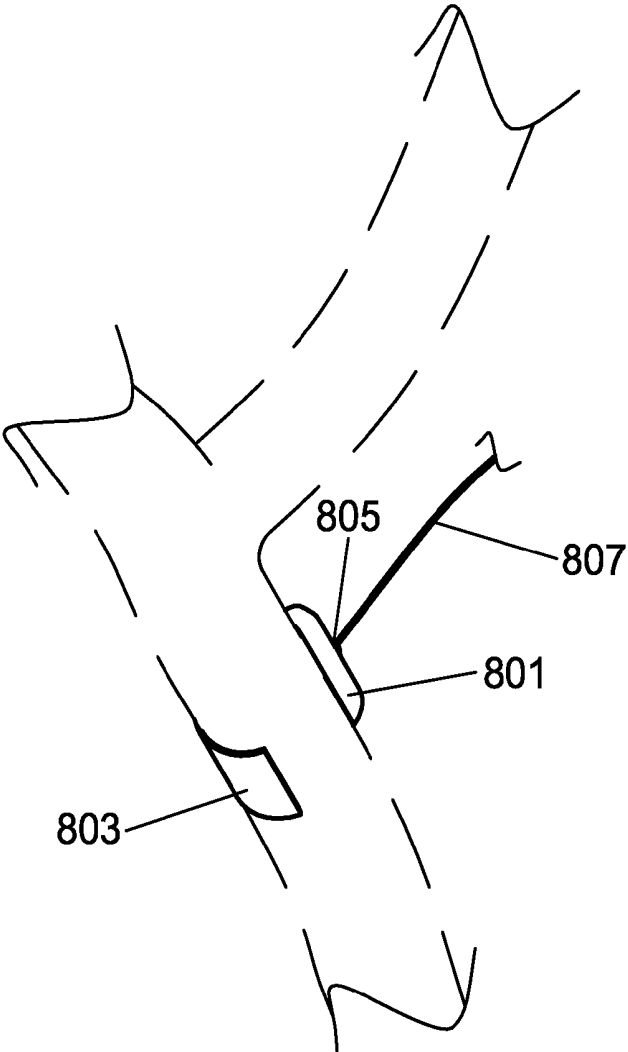

Fig. 9

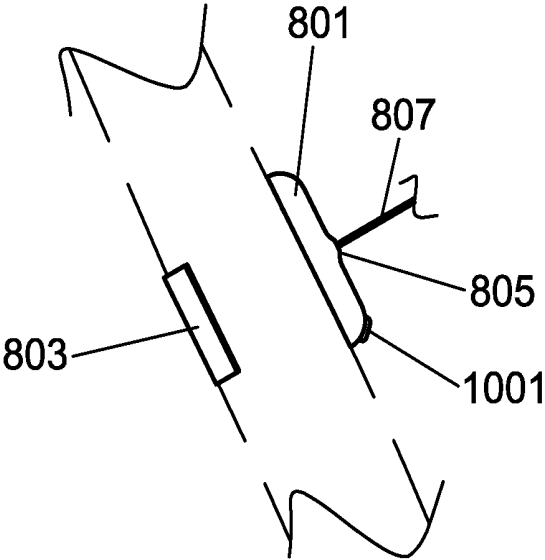

Fig. 10

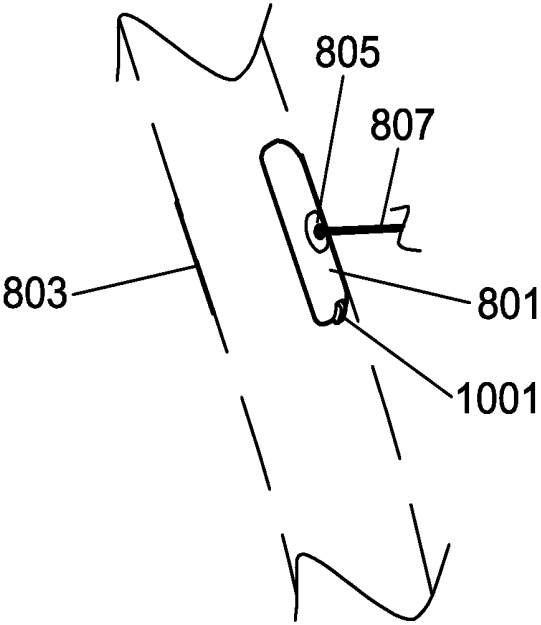

Fig. 11

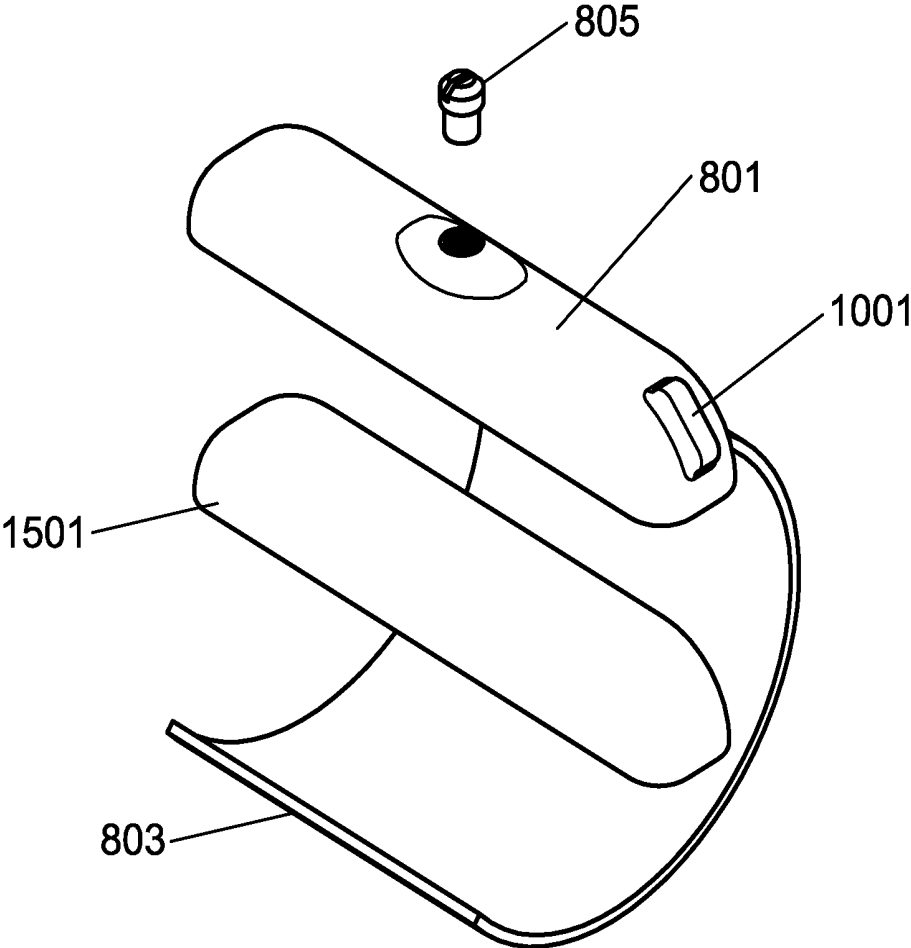

Fig. 12

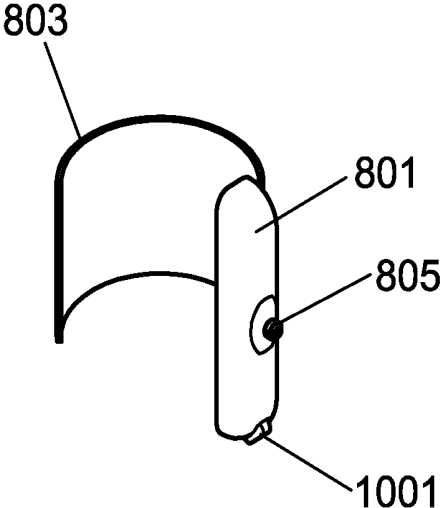

Fig. 13

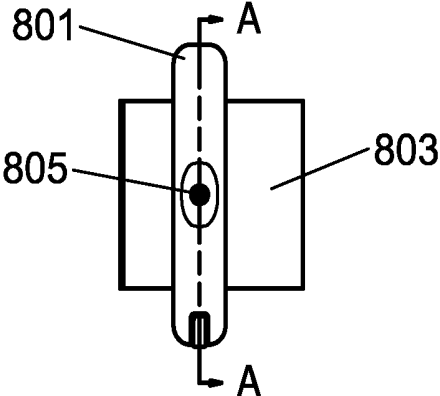

Fig. 14

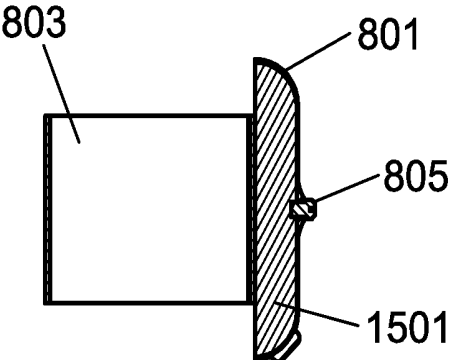

Fig. 15

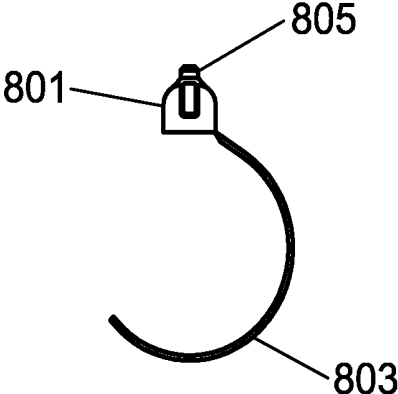

Fig. 16

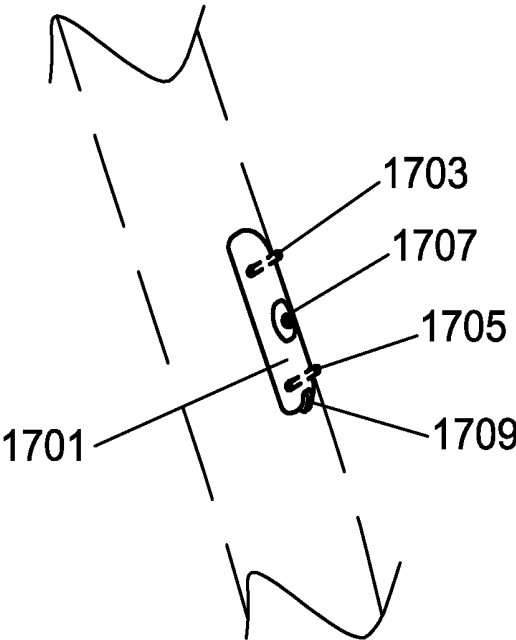

Fig. 17

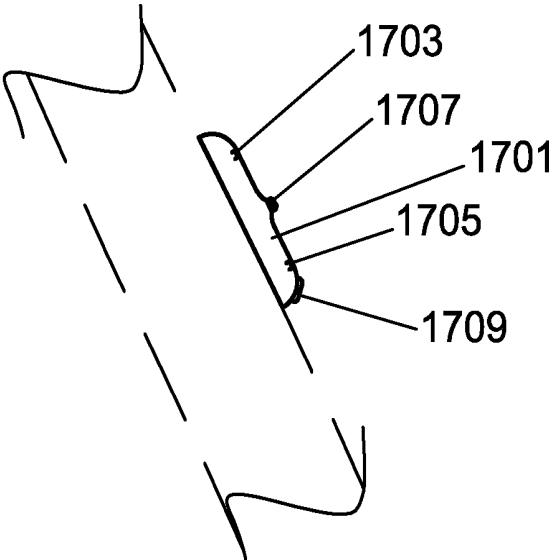

Fig. 18

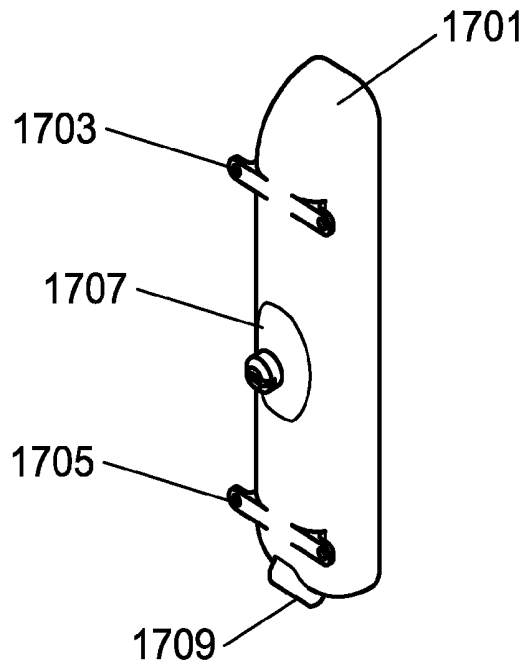

Fig. 19

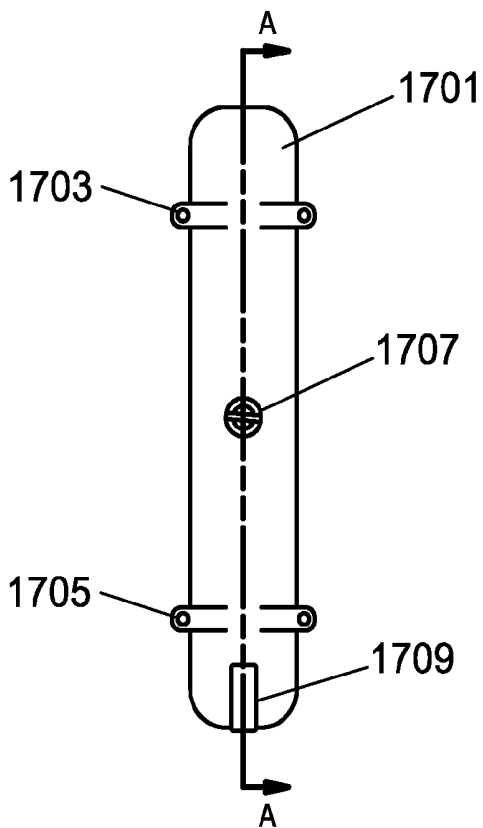

Fig. 20

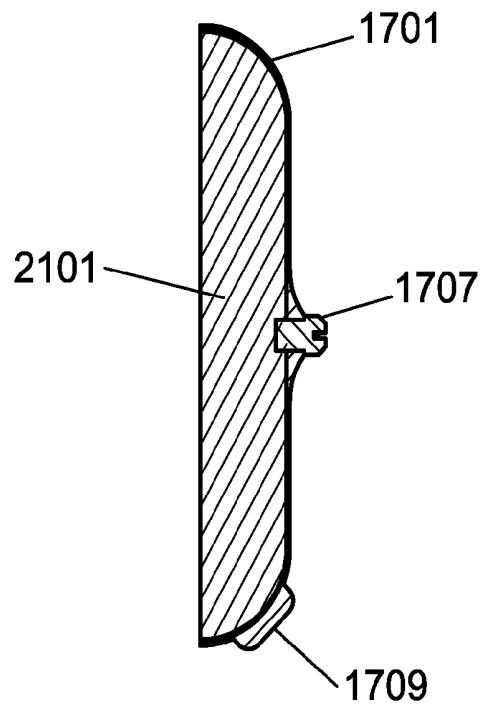

Fig. 21

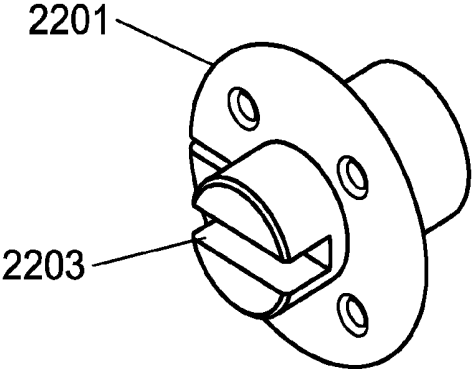

Fig. 22

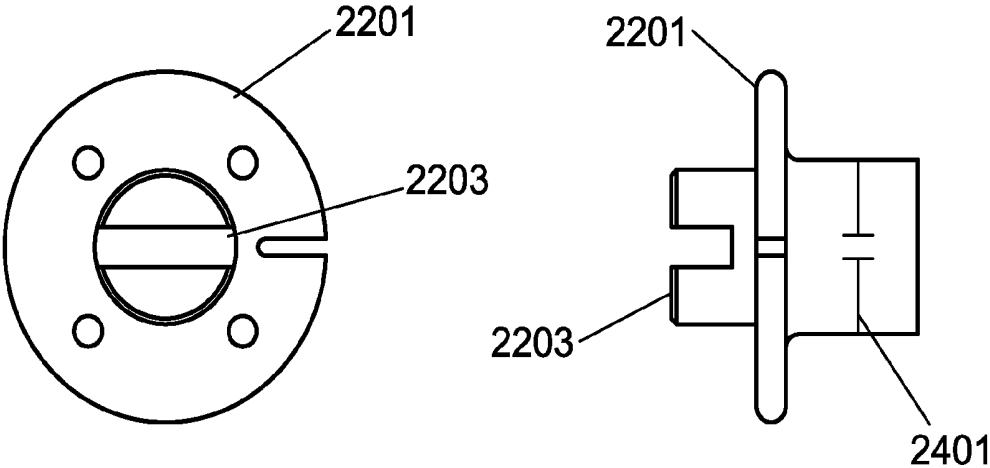

Fig. 23

Fig. 24

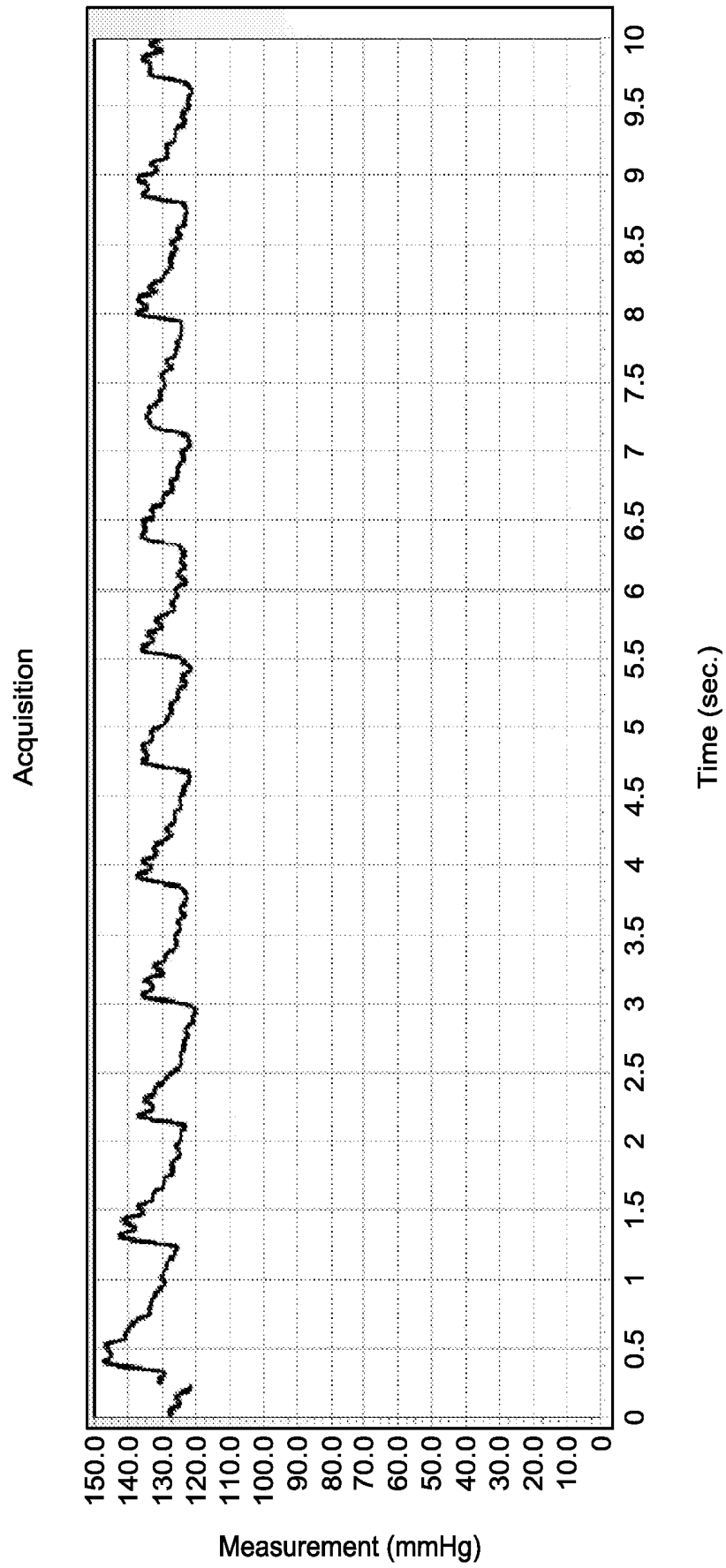

Fig. 25

IMPLANTABLE PRESSURE MONITOR

[0001] This application claims priority to U.S. Patent Application Ser. No. 61/731,742 filed Nov. 30, 2012 entitled IMPLANTABLE PRESSURE MONITOR by Jason Haitao Huang and Samantha Dayawansa and to International Application Number PCT/US13/71757 filed Nov. 25, 2013 entitled IMPLANTABLE PRESSURE MONITOR by Jason Haitao Huang and Samantha Dayawansa, the entire disclosures of which are incorporated herein by reference.

TECHNICAL FIELD

[0002] The present invention relates generally to medical devices, and more particularly to an implantable pressure monitor that has a variety of applications such as blood pressure monitoring, aneurism monitoring, and the like.

BACKGROUND ART

[0003] The ability to monitor pressure in a living organism such as an animal or a human has numerous applications ranging from blood pressure monitoring to monitoring medical conditions such as aneurisms and the like. While monitoring blood pressure through the skin, for example, is known, the accuracy of such devices may be questionable. Targeted pressure monitoring of a medical condition such as an aneurism requires a precise and reliable device. Such a device should be non-invasive to the vessel itself to prevent problems associated with penetration of the blood vessel.

[0004] While monitoring of blood pressure or other pressure within a body is often done on a transitory basis, there are situations that require comprehensive continuous monitoring. For example, an aneurism may require continuous monitoring to ensure that it does not continue to grow in size and rupture. The ability to continuously monitor an aneurism, and provide the patient or a medical practitioner with real-time information related to their condition is something that has heretofore been unknown. Such continuous real-time monitoring allows immediate action to be taken in the event that the patient becomes at risk. Currently, aneurism monitoring involves regular surveillance imaging that requires a visit to a medical practitioner for each check of the condition of the aneurism. There is no real-time monitoring system that could provide pressure readouts on an instrument that could, for example, be worn on a patient's wrist, or provide the data to a remote monitoring device by way of a computer network, a wireless network, or the like.

[0005] It is thus an object of the present invention to provide an implantable pressure monitor that is non-invasive to the vessel or body part to which pressure is being monitored. It is another object of the present invention to provide an implantable pressure monitor that can provide data to a remote device such as a hospital monitor, smart phone, or other such electronic device. It is another object of the present invention to provide an implantable pressure monitor that provides real time status on medical conditions such as aneurisms. It is yet another object of the present invention to provide an implantable pressure monitor that provides real time blood pressure data. It is a further object of the present invention to provide an above skin blood pressure monitor. These and other objects of the present invention are not to be considered comprehensive or exhaustive, but rather, exemplary of objects that may be ascertained after reading this specification and claims in view of the accompanying drawings.

DISCLOSURE OF THE INVENTION

[0006] In accordance with the present invention, there is provided an implantable pressure monitor comprising a pressure monitor housing, a fluid sack retained by the pressure monitor housing, a liquid contained within the fluid sack, a fistula with a fluid valve that terminates through the fluid sack, an opening in the pressure monitor housing for access to the fistula, and a fiber optic pressure sensor in contact with the fluid by way of the fistula and fluid valve.

[0007] The foregoing paragraph has been provided by way of introduction, and is not intended to limit the scope of the invention as described by this specification, claims and the attached drawings.

BRIEF DESCRIPTION OF THE DRAWINGS

[0008] The invention will be described by reference to the following drawings, in which like numerals refer to like elements, and in which:

[0009] FIG. 1 is a perspective view of a wrap around pressure monitor on a vessel;

[0010] FIG. 2 is a plan view of the wrap around pressure monitor of FIG. 1;

[0011] FIG. 3 is a rotated plan view of the wrap around pressure monitor of FIG. 1;

[0012] FIG. 4 is a rotated perspective view of the wrap around pressure monitor of FIG. 1;

[0013] FIG. 5 is a perspective view of the wrap around pressure monitor of FIG. 1 without the fiber optic sensor;

[0014] FIG. 6 is a perspective view of the wrap around pressure monitor of FIG. 1 in the open position;

[0015] FIG. 7 is an exploded view of the wrap around pressure monitor of FIG. 1 in the open position;

[0016] FIG. 8 is a perspective view of a strap based pressure monitor on a vessel;

[0017] FIG. 9 is a rotated perspective view of the strap based pressure monitor of FIG. 8;

[0018] FIG. 10 is a rotated plan view of the strap based pressure monitor of FIG. 8;

[0019] FIG. 11 is a top perspective view of the strap based pressure monitor of FIG. 8;

[0020] FIG. 12 is an exploded perspective view of the strap based pressure monitor of FIG. 8;

[0021] FIG. 13 is a perspective view of the strap based pressure monitor of FIG. 8 without the fiber optic pressure sensor;

[0022] FIG. 14 is a plan view of the strap based pressure monitor of FIG. 8 without the fiber optic pressure sensor;

[0023] FIG. 15 is a plan view of the strap based pressure monitor cut along line A-A of FIG. 14;

[0024] FIG. 16 is an end view of the strap based pressure monitor of FIG. 8 without the fiber optic sensor;

[0025] FIG. 17 is a perspective view of a suture tab pressure monitor on a vessel;

[0026] FIG. 18 is a side plan view of the suture tab pressure monitor of FIG. 17;

[0027] FIG. 19 is a perspective view of the suture tab pressure monitor of FIG. 17;

[0028] FIG. 20 is a top plan view of the suture tab pressure monitor of FIG. 17;

[0029] FIG. 21 is a plan view of the suture tab pressure monitor cut along line A-A of FIG. 20;

[0030] FIG. 22 is a perspective view of a fistula of the present invention:

[0031] FIG. 23 is a side plan view of a fistula of the present invention;

[0032] FIG. 24 is a top plan view of a fistula of the present invention; and

[0033] FIG. 25 is a chart recording of micro movements of a patient's skin over the external carotid artery expressed as pressure vs. time.

[0034] The present invention will be described in connection with a preferred embodiment, however, it will be understood that there is no intent to limit the invention to the embodiment described. On the contrary, the intent is to cover all alternatives, modifications, and equivalents as may be included within the spirit and scope of the invention as defined by this specification, claims and drawings attached hereto.

BEST MODE FOR CARRYING OUT THE INVENTION

[0035] The implantable pressure monitor of the present invention may have various embodiments, some of which are described herein, and others of which may be inferred from or otherwise envisioned based on the disclosure contained herein.

[0036] The implantable pressure monitor makes use of small changes in a body part (human or animal) to determine pressure. For example, a blood vessel experiences small "micro" movements as blood travels through the blood vessel. These movements can be correlated to blood pressure. In a similar way, pressure buildup in an organ or other body part can be detected by the implantable pressure monitor, providing an alert to a pending medical emergency. The implantable pressure monitor relies on the use of a fiber optic pressure sensor and a novel pressure sensing structure. The fiber optic pressure sensor may, in one embodiment of the present invention, be structured as a Fabry-Perot Interferometer such as the one disclosed in U.S. Pat. No. 7,684,657 to Donlagic et al. and entitled "Single Piece Fabry-Perot Optical Sensor And Method of Manufacturing Same", the entire disclosure of which is incorporated herein by reference in its entirety. Other fiber optic pressure sensors may also be employed, and may, in some embodiments of the present invention, contain a moveable structure such as a diaphragm that changes position in relation to a reference (such as the end of the optical fiber) under varying pressure conditions to in turn provide pressure measurements through, for example, optical means. An example of a suitable fiber optic pressure sensor is the model FOP-F125 Pressure Sensor manufactured by FISO Technologies, Inc. of Quebec, Canada. The pressure sensing structure comprises a fluid filled sack that makes contact with the body part of which pressure is to be monitored. The fiber optic pressure sensor is in communication with the liquid contained in the fluid sack. This arrangement allows for sensing of small movements across a greater surface area, as opposed to what would essentially be a point source with the fiber optic pressure sensor alone. The fluid sack is in turn attached to the body part, for example a blood vessel like the aorta, by way of an accommodating and suitably shaped pressure monitor housing. The fiber optic pressure sensor may then be run outside the body to appropriate instrumentation to provide pressure readings, alerts, and the like. In some embodiments of the present invention, the fiber optic pressure sensor may terminate with an electronics module that is contained with the implantable pressure monitor. The electronics module in turn provides telemetry data to a hos-

pital monitor, a smart phone, or other such electronic device that can provide pressure readings, alerts, alarms, and the like.

[0037] Several embodiments of the present invention will be described by way of the figures where FIGS. 1-7 describe a first embodiment, FIGS. 8-16 describe a second embodiment, and FIGS. 17-21 describe a third embodiment. The embodiments described and depicted herein are intended primarily for use with a blood vessel and related pressure measurements. One can envision after reading this disclosure an implantable pressure monitor that has a different shape and size to accommodate pressure monitoring of other anatomical parts such as, for example, internal organs. Such changes being considered within the spirit and broad scope of the present invention as described and depicted herein. In addition, an external, non-implantable pressure monitor using the fiber optic pressure sensor and the techniques described herein is also to be considered within the spirit and scope of the present invention. An output chart of such an embodiment of the present invention being depicted in FIG. 25.

[0038] A first embodiment of the present invention, as depicted in FIGS. 1-7, attaches to a blood vessel by way of several retention parts that fold or hinge together. FIG. 1 is a perspective view of a wrap around pressure monitor on a vessel. A fluid sack 109 can be seen in contact with the blood vessel. The fluid sack 109 may be made from, for example, a metal foil, such as an aluminum foil, with suitable biocompatible coatings as necessary. The fluid sack 109 may also be made from a biocompatible cloth such as polyethylene terephthalate, also with suitable coatings as necessary. The fluid sack 109 contains a liquid such as, for example, silicone oil, that serves to transmit small movements of the blood vessel that correspond to pressure changes. Other liquids may also be employed such as a saline solution, water, or the like. Higher viscosity fluids are preferred due to their ability to transmit small pressure changes, but the present invention is not limited to such fluids. In fact, in some embodiments of the present invention, the fluid sack 109 may instead contain a gas, a gel, or the like. The fluid sack 109 may be of a shape conformal to the first retention part 101 and the second retention part 103. A fistula 105 having a fluid valve terminates through the fluid sack 109 so as to provide a liquid (or gas or gel) tight seal when the fiber optic pressure sensor 107 is placed through the fistula 105 and into the liquid, gas or gel contained in the fluid sack 109. The fistula 105 is made from a biocompatible material such as a stainless steel, a biocompatible plastic such as Polyethylene, Polysulfone, Polypropylene, or the like. A fistula, as used herein, refers to any opening, device, apparatus, seal, or structure that provides access to the inside of the fluid sack while keeping to contents of the fluid sack contained within. The fistula may, in some embodiments of the present invention, contain a fluid valve, seal, gasket, fitting, or similar structure to ensure a complete seal once the fiber optic pressure sensor is inserted into the fluid sack. The fistula may also simply be a pass through or via and may have suitable sealing material to ensure a leak free fit. The fistula 105 may be made by machining, casting, molding, or the like. An example of a suitable fistula can be seen in FIGS. 22-24. The fistula 105 seals to the fluid sack 109 using mechanical and sealant means, and also may contain a valve that may be a membrane or similar structure for sealing the liquid, gas or gel to the confines of the fluid sack 109 when the fiber optic pressure sensor 107 is inserted through the fistula 105 into the fluid sack 109. The fistula 105 passes through the pressure monitor housing by way of an opening in the first

retention part **101** or the second retention part **103**. To hold the fluid sack **109** against the blood vessel, a pressure monitor housing can be seen comprising a first retention part **101** and a second retention part **103**. The first retention part **101** and the second retention part **103** may be made from a biocompatible material such as a stainless steel, a biocompatible plastic such as Polyethylene, Polysulfone, Polypropylene, or the like. The first retention part **101** and the second retention part **103** may be made by machining, casting, molding, or the like. Such an arrangement can be hinged, pinned, or otherwise connected so that the first retention part **101** and the second retention part **103** close around the fluid sack **109** in such a way that proper communication of small movements in the vessel are sent through the fluid contained in the fluid sack **109** to the fiber optic pressure sensor **107**. The first retention part **101** and the second retention part **103** may, in some embodiments of the present invention, be one and the same (a single structure). For placement around vessels, the first retention part **101** and the second retention part **103** have a generally cylindrical inner cavity or surface to accommodate a vessel such as an artery or the like. In some embodiments of the present invention, the first retention part **101** and the second retention part **103** are of a similar shape and geometry and may be curved or otherwise shaped to conform to a vessel. In other embodiments of the present invention, the first retention part **101** and the second retention part **103** are of differing shape and geometry and may have areas where the fluid sack **109** is exposed or otherwise free from the first retention part **101** or the second retention part **103**. The fiber optic pressure sensor **107** may, in one embodiment of the present invention, be structured as a Fabry-Perot Interferometer or otherwise contain a moveable structure such as a diaphragm that changes position in relation to a reference such as the end of the optical fiber under varying pressure conditions to in turn provide pressure measurements through, for example, optical means. A light source (not depicted) may be provided in optical communication with the fiber optic pressure sensor to provide an optical signal to the fiber optic pressure sensor, and a fiber optic receiver may be employed to receive the optical signal from the fiber optic pressure sensor. The received optical signal containing information that correlates with pressure readings, as seen, for example, in FIG. **25**.

[0039] The first retention part **101** and the second retention part **103** do not necessarily wrap completely around the blood vessel. FIG. **2** is a plan view of the wrap around pressure monitor of FIG. **1** showing a generally open side with the fluid sack **109**.

[0040] FIG. **3** is a rotated plan view of the wrap around pressure monitor of the present invention and FIG. **4** is a rotated perspective view of the wrap around pressure monitor of the present invention. The fiber optic pressure sensor **807** can be seen exiting the fistula **105**. The overall shape of the pressure monitor of the present invention may be, for example, a prolate spheroid or other similar geometry. Preferably, the shape of the pressure monitor should be devoid of sharp edges when implanted to avoid surgical complications. Various coatings may be applied to the pressure monitor such as drug eluting coatings and the like. In some embodiments of the present invention, the housing of the pressure monitor also serves to attach the pressure monitor to an anatomical part, either as a function of its overall geometry, or as a function of features such as, for example, suture tabs, clamps, pins, and the like.

[0041] FIG. **5** is a perspective view of the wrap around pressure monitor without the fiber optic sensor. FIG. **6** is a perspective view of the wrap around pressure monitor of FIG. **1** in the open position, and FIG. **7** is an exploded view of the wrap around pressure monitor in the open position showing clearly the fluid sack **109** within the pressure monitor housing. The embodiment depicted by way of FIGS. **1-7** may be useful, for example, with laboratory animals such as rats. The fiber optics will leave the body of the laboratory animal or human through a suitable fistula, and be connected to an appropriate interface that generates and reads the optical signals necessary to drive the fiber optic pressure sensor.

[0042] For applications that include use with humans, the overall pressure monitor should preferably be small in relation to the blood vessel or organ to which pressure is to be monitored. In addition, while in some clinical applications it may be acceptable to have the fiber optics leave the body through a suitable fistula, it oftentimes will be desirable to have electronics that provide the pressure data via telemetry to a receiving unit such as a hospital monitor, a smart phone, or other such electronic device that can provide pressure readings, alerts, alarms, and the like. These electronics may be integral with, or attached to, the pressure monitor, or may otherwise be in physical proximity to the pressure monitor of the present invention.

[0043] FIGS. **8-16** describe a second embodiment of the implantable pressure monitor where the pressure monitor housing **801** is attached to the vessel, organ, or other anatomical part by way of a strap **803** as seen in the perspective view of FIG. **8**. The strap **803** may be made from a suitable biocompatible material such as, for example, a biocompatible cloth such as, for example, polyethylene terephthalate. The strap **803** is an attachment structure for placing the pressure monitor on a body part. Other attachment structures such as hooks, pins, mesh, and the like may also be employed.

[0044] FIG. **8** is a perspective view of the strap based pressure monitor on a blood vessel. A fluid sack is contained within the pressure monitor housing **801** such that it makes contact with the blood vessel. The fluid sack can be seen in the cutaway view of FIG. **15** (see **1501**). The fluid sack may be made from a metal foil, such as an aluminum foil, with suitable biocompatible coatings as necessary. The fluid sack may also be made from a biocompatible cloth such as polyethylene terephthalate, also with suitable coatings as necessary. The fluid sack contains a liquid such as, for example, silicone oil, that serves to transmit small movements of the blood vessel that correspond to pressure changes. Other liquids may also be employed such as a saline solution, water, or the like. Higher viscosity fluids are preferred due to their ability to transmit small pressure changes, but the present invention is not limited to such fluids. In fact, in some embodiments of the present invention, the fluid sack may instead contain a gas, a gel, or the like. A fistula **805** having a fluid valve terminates through the fluid sack so as to provide a liquid (or gas or gel) tight seal when the fiber optic pressure sensor **807** is placed through the fistula **805** and into the liquid, gas or gel contained in the fluid sack. The fistula **805** is made from a biocompatible material such as a stainless steel, a biocompatible plastic such as Polyethylene, Polysulfone, Polypropylene, or the like. A fistula, as used herein, refers to any opening, device, apparatus, seal, or structure that provides access to the inside of the fluid sack while keeping to contents of the fluid sack contained within. The fistula may, in some embodiments of the present invention, contain a fluid valve, seal, gasket, fitting, or

similar structure to ensure a complete seal once the fiber optic pressure sensor is inserted into the fluid sack. The fistula may also simply be a pass through or via and may have suitable sealing material to ensure a leak free fit. The fistula **805** may be made by machining, casting, molding, or the like. An example of a suitable fistula can be seen in FIGS. **22-24**. The fistula **805** seals to the fluid sack using mechanical and sealant means, and also may contain a valve that may be a membrane or similar structure for sealing the liquid, gas or gel to the confines of the fluid sack when the fiber optic pressure sensor **807** is inserted through the fistula **805** into the fluid sack. The fistula **805** passes through the pressure monitor housing by way of an opening. To hold the fluid sack against the blood vessel, a pressure monitor housing **801** can be seen. The pressure monitor housing **801** may be made from a biocompatible material such as a stainless steel, a biocompatible plastic such as Polyethylene, Polysulfone, Polypropylene, or the like. The pressure monitor housing **801** may be made by machining, casting, molding, or the like. The pressure monitor housing **801** encompasses the fluid sack in such a way that proper communication of small movements in the vessel are sent through the fluid contained in the fluid sack to the fiber optic pressure sensor **807**. The fiber optic pressure sensor **807** may, in one embodiment of the present invention, be structured as a Fabry-Perot Interferometer or otherwise contain a moveable structure such as a diaphragm that changes position in relation to a reference such as the end of the optical fiber under varying pressure conditions to in turn provide pressure measurements through, for example, optical means. Other attributes and components from the pressure monitor disclosed by way of FIGS. **1-7** may also be incorporated with the embodiment depicted in FIGS. **8-16**.

[0045] FIG. **9** is a rotated perspective view of the strap based pressure monitor. It should be noted that the strap **803** is shown as not completely encompassing the blood vessel or anatomical part. The overall geometry of the strap **803** including its length and width may vary based on the application, and in some embodiments of the present invention, the strap **803** may fully encompass the blood vessel or anatomical part.

[0046] FIG. **10** is a rotated plan view of the strap based pressure monitor. Shown in FIG. **10** is an electronics module **1001** that contains telemetry circuitry and power circuitry. The electronics module **1001** employs miniaturization techniques such as microelectronic design and packaging, hybrid circuit design and packaging, and the like. The electronics module **1001** contains an energy storage device that may be a battery, or may be a capacitor such as an ultracapacitor or the like. Suitable batteries include, but are not limited to, lithium ion implantable batteries or other microbatteries that are implantable. To charge the energy storage device, a charging coil may be employed that provides inductively coupled charging from an external source of electromagnetic radiation. Such an arrangement is described in United States Patent Application Publication US2009/0289595 A1 to Chen et al. and entitled "Wireless Charging Module and Electronic Apparatus", the entire disclosure of which is incorporated herein by reference. The charging coil (not shown) is made from a conductive material such as copper, and may be coiled or formed as a spiral. The conductive material may further be a wire, flat stock, printed conductive film, or the like. In addition, in some embodiments of the present invention, an energy harvesting device such as a MEMS device or a piezoelectric device to convert kinetic energy of the body into electrical energy is used to charge the energy storage device.

The energy storage device contained within the electronics module **1001** provides power to the telemetry circuitry. The telemetry circuitry includes a fiber optic receiver with appropriate fiber optic terminations to receive the distal end of the fiber optic pressure sensor, which may, in some embodiments of the present invention, be contained within the pressure monitor housing **801**. The telemetry circuitry contains both optical transmit and receive functionality as well as logic and related circuits to convert the optical signals from the fiber optic pressure sensor **807** into pressure data that is in turn transmitted from the electronics module **1001** to an external receiving unit such as a hospital monitor, smart phone, computer, or the like. The electronics module **1001** contains a radiofrequency transmitter capable of sending the pressure data, or may, in some embodiments of the present invention, contain circuitry capable of being interrogated by an external device and send the pressure data on demand. FIG. **11** is a top perspective view of the strap based pressure monitor. FIG. **12** is an exploded perspective view of the strap based pressure monitor depicting the fluid sack and related pressure monitor housing. FIG. **13** is a perspective view of the strap based pressure monitor without the fiber optic pressure sensor visible. As stated previously, the fiber optic pressure sensor may be terminated within the pressure monitor housing to the electronics module **1001** in some embodiments of the present invention.

[0047] FIG. **14** is a plan view of the strap based pressure monitor without the fiber optic sensor visible and FIG. **15** is a plan view of the strap based pressure monitor cut along line A-A of FIG. **14**. The internal fluid sack **1501** and internal fluid can be seen as the crosshatched area depicted. FIG. **16** is an end view of the strap based pressure monitor without the fiber optic sensor visible.

[0048] Similar to FIGS. **8-16** except for the mounting structure, FIGS. **17-21** describe a third embodiment of the implantable pressure monitor where the pressure monitor housing **1701** is attached to the vessel, organ, or other anatomical part by way of suture tabs such as the first suture tab **1703** and the second suture tab **1705** as seen in the perspective view of FIG. **17**. The suture tabs are an attachment structure for placing the pressure monitor on a body part. Other attachment structures such as hooks, pins, mesh, and the like may also be employed. The suture tabs may be made from a biocompatible material such as a stainless steel, a biocompatible plastic such as Polyethylene, Polysulfone, Polypropylene, or the like. The suture tabs may be made by machining, casting, molding, or the like, and may be cast, molded, machined, or otherwise formed with the pressure monitor housing **1701**. Other attributes and components from the pressure monitor disclosed by way of FIGS. **1-7** and FIGS. **8-16** may also be incorporated with the embodiment depicted in FIGS. **17-21**.

[0049] FIG. **17** is a perspective view of a suture tab pressure monitor on a blood vessel. A fluid sack is contained within the pressure monitor housing **1701** such that it makes contact with the blood vessel. The fluid sack can be seen in the cutaway view of FIG. **21** (see **2101**). The fluid sack may be made from a metal foil, such as an aluminum foil, with suitable biocompatible coatings as necessary. The fluid sack may also be made from a biocompatible cloth such as polyethylene terephthalate, also with suitable coatings as necessary. The fluid sack contains a liquid such as, for example, silicone oil, that serves to transmit small movements of the blood vessel that correspond to pressure changes. Other liquids may

also be employed such as a saline solution, water, or the like. Higher viscosity fluids are preferred due to their ability to transmit small pressure changes, but the present invention is not limited to such fluids. In fact, in some embodiments of the present invention, the fluid sack may instead contain a gas, a gel, or the like. A fistula **1707** having a fluid valve terminates through the fluid sack so as to provide a liquid (or gas or gel) tight seal when the fiber optic pressure sensor (not shown) is placed through the fistula **1707** and into the liquid, gas or gel contained in the fluid sack. The fistula **1707** is made from a biocompatible material such as a stainless steel, a biocompatible plastic such as Polyethylene, Polysulfone, Polypropylene, or the like. A fistula, as used herein, refers to any opening, device, apparatus, seal, or structure that provides access to the inside of the fluid sack while keeping to contents of the fluid sack contained within. The fistula may, in some embodiments of the present invention, contain a fluid valve, seal, gasket, fitting, or similar structure to ensure a complete seal once the fiber optic pressure sensor is inserted into the fluid sack. The fistula may also simply be a pass through or via and may have suitable sealing material to ensure a leak free fit. The fistula **1707** may be made by machining, casting, molding, or the like. An example of a suitable fistula can be seen in FIGS. **22-24**. The fistula **1707** seals to the fluid sack using mechanical and sealant means, and also may contain a valve that may be a membrane or similar structure for sealing the liquid, gas or gel to the confines of the fluid sack when the fiber optic pressure sensor is inserted through the fistula **1707** into the fluid sack. The fistula **1707** passes through the pressure monitor housing by way of an opening. To hold the fluid sack against the blood vessel, a pressure monitor housing **1701** can be seen. The pressure monitor housing **1701** may be made from a biocompatible material such as a stainless steel, a biocompatible plastic such as Polyethylene, Polysulfone, Polypropylene, or the like. The pressure monitor housing **1701** may be made by machining, casting, molding, or the like. The pressure monitor housing **1701** encompasses the fluid sack in such a way that proper communication of small movements in the vessel are sent through the fluid contained in the fluid sack to the fiber optic pressure sensor. The fiber optic pressure sensor may, in one embodiment of the present invention, be structured as a Fabry-Perot Interferometer or otherwise contain a moveable structure such as a diaphragm that changes position in relation to a reference such as the end of the optical fiber under varying pressure conditions to in turn provide pressure measurements through, for example, optical means.

[0050] Also depicted in FIG. **17** is an electronics module **1709** that contains telemetry circuitry and power circuitry. The electronics module **1709** employs miniaturization techniques such as microelectronic design and packaging, hybrid circuit design and packaging, and the like. The electronics module **1709** contains an energy storage device that may be a battery, or may be a capacitor such as an ultracapacitor or the like. Suitable batteries include, but are not limited to, lithium ion implantable batteries or other microbatteries that are implantable. To charge the energy storage device, a charging coil may be employed that provides inductively coupled charging from an external source of electromagnetic radiation. Such an arrangement is described in United States Patent Application Publication US2009/0289595 A1 to Chen et al. and entitled "Wireless Charging Module and Electronic Apparatus", the entire disclosure of which is incorporated herein by reference. The charging coil (not shown) is made

from a conductive material such as copper, and may be coiled or formed as a spiral. The conductive material may further be a wire, flat stock, printed conductive film, or the like. In addition, in some embodiments of the present invention, an energy harvesting device such as a MEMS device or a piezoelectric device to convert kinetic energy of the body into electrical energy is used to charge the energy storage device. The energy storage device contained within the electronics module **1709** provides power to the telemetry circuitry. The telemetry circuitry includes a fiber optic receiver with appropriate fiber optic terminations to receive the distal end of the fiber optic pressure sensor, which may, in some embodiments of the present invention, be contained within the pressure monitor housing **1701**. The telemetry circuitry contains both optical transmit and receive functionality as well as logic and related circuits to convert the optical signals from the fiber optic pressure sensor into pressure data that is in turn transmitted from the electronics module **1709** to an external receiving unit such as a hospital monitor, smart phone, computer, or the like. The electronics module **1709** contains a radiofrequency transmitter capable of sending the pressure data, or may, in some embodiments of the present invention, contain circuitry capable of being interrogated by an external device and send the pressure data on demand.

[0051] FIG. **18** is a side plan view of the suture tab pressure monitor in use on a blood vessel. FIG. **19** is a perspective view of the suture tab pressure monitor showing the suture tabs used to hold the pressure monitor in place. FIG. **20** is a top plan view of the suture tab pressure monitor. FIG. **21** is a plan view of the suture tab pressure monitor cut along line A-A of FIG. **20** showing the fluid sack **2101** and internal fluid by way of the cross hatched area.

[0052] FIGS. **22-24** depict an exemplary fistula of the present invention. FIG. **22** is a perspective view of a fistula **2201**. The fiber optic pressure sensor port **2203** can be seen. FIG. **23** is a side plan view of the fistula **2201** where a valve **2401** can be seen. The valve **2401** provides a liquid (or gas or gel) tight seal when the fiber optic pressure sensor is placed through the fistula and into the liquid, gas or gel contained in the fluid sack. The valve **2401** may be made from a membrane, a flexible silicone rubber, a mechanical fixture, or the like. The fistula **2201** is made from a biocompatible material such as a stainless steel, a biocompatible plastic such as Polyethylene, Polysulfone, Polypropylene, or the like. A fistula, as used herein, refers to any opening, device, apparatus, seal, or structure that provides access to the inside of the fluid sack while keeping to contents of the fluid sack contained within. The fistula may, in some embodiments of the present invention, contain a fluid valve, seal, gasket, fitting, or similar structure to ensure a complete seal once the fiber optic pressure sensor is inserted into the fluid sack. The fistula may also simply be a pass through or via and may have suitable sealing material to ensure a leak free fit. The fistula **2201** may be made by machining, casting, molding, or the like. The fiber optic pressure sensor port **2203** is depicted as a slot, but other embodiments of the present invention use varying geometries. In addition, the overall geometry of the fistula **2201** may vary from one embodiment to another. FIG. **24** is a top plan view of a fistula of the present invention.

[0053] FIG. **25** is a chart recording of micro movements of a patient's skin over the external carotid artery expressed as pressure vs. time. An above the skin version of the present invention contains the fiber optic pressure sensor in direct contact with the skin above a monitoring point such as the

external carotid artery. Small movements of the skin can be directly correlated with pressure changes. The chart in FIG. 25, for example, depicts pressure changes in the range of 120 to 149 millimeters of mercury. The chart in FIG. 25 has a y-axis range from zero to 150.0. The scale is thus millimeters of mercury (mm. Hg). In some embodiments of the present invention, a fluid sack, such as the fluid sack previously described herein, is placed between the patient's skin and the fiber optic pressure sensor. Such an arrangement may be packaged in a suitable housing, and may contain electronics to transmit the pressure information to a receiving device for subsequent display or storage. The receiving device may be worn on the patient's wrist, or it may be a device that is connected to a computer network for subsequent data transmission, display, and storage.

[0054] To use the implantable pressure monitor, the fluid sack is placed against the blood vessel, organ, or anatomical part of interest. The pressure monitor housing containing the fluid sack is then attached by way of a strap, sutures, retention parts, or the like. The fiber optic pressure sensor is then either guided outside the body or terminated with the electronics module.

[0055] While the pressure monitor described herein is suitable for implantation, the use of the novel pressure sensing structure (fluid sack and related fixtures) and fiber optic pressure sensor in above skin applications is also to be considered within the spirit and broad scope of the present invention.

[0056] It is, therefore, apparent that there has been provided, in accordance with the various objects of the present invention, an implantable pressure monitor.

[0057] While the various objects of this invention have been described in conjunction with preferred embodiments thereof, it is evident that many alternatives, modifications, and variations will be apparent to those skilled in the art. Accordingly, it is intended to embrace all such alternatives, modifications and variations that fall within the spirit and broad scope of this specification, claims, and drawings appended herein.

What is claimed is:

1. An implantable pressure monitor comprising:
 - a pressure monitor housing;
 - a fluid sack retained by the pressure monitor housing;
 - a liquid contained within the fluid sack;
 - a fistula with a fluid valve that terminates through the fluid sack;
 - an opening in the pressure monitor housing for access to the fistula; and
 - a fiber optic pressure sensor in communication with the liquid by way of the fistula and fluid valve.
2. The implantable pressure monitor of claim 1, wherein the pressure monitor housing comprises a first retention part and a second retention part mechanically joined together.
3. The implantable pressure monitor of claim 1, wherein the pressure sensor is a Fabry-Perot Interferometer.
4. The implantable pressure monitor of claim 1, further comprising an electronics module coupled to the pressure sensor.

5. The implantable pressure monitor of claim 1, wherein the liquid contained within the fluid sack is a high viscosity liquid.

6. The implantable pressure monitor of claim 1, wherein the pressure monitor housing has the general shape of a prolate spheroid.

7. A pressure monitor comprising:

- a pressure monitor housing;
- a fluid sack retained by the pressure monitor housing;
- an opening in the pressure monitor housing to allow the fluid sack to make contact with a body part of a patient;
- a liquid contained within the fluid sack;
- a fistula with a fluid valve that terminates through the fluid sack; and
- a fiber optic pressure sensor in communication with the liquid by way of the fistula and fluid valve.

8. The pressure monitor of claim 7, further comprising an electronics module coupled to the pressure sensor.

9. The pressure monitor of claim 7, wherein the pressure sensor is a Fabry-Perot Interferometer.

10. The pressure monitor of claim 7, further comprising an electronics module coupled to the pressure sensor.

11. The pressure monitor of claim 7, wherein the liquid contained within the fluid sack is a high viscosity liquid.

12. An implantable pressure monitor comprising:

- a pressure monitor housing;
- an attachment structure mechanically affixed to the pressure monitor housing;
- a fluid sack retained by the pressure monitor housing;
- a liquid contained within the fluid sack;
- a fistula with a fluid valve that terminates through the fluid sack;
- an opening in the pressure monitor housing for access to the fistula; and
- a fiber optic pressure sensor in communication with the liquid by way of the fistula and fluid valve.

13. The implantable pressure monitor of claim 12, wherein the pressure sensor is a Fabry-Perot Interferometer.

14. The implantable pressure monitor of claim 12, further comprising an electronics module coupled to the pressure sensor.

15. The implantable pressure monitor of claim 12, wherein the liquid contained within the fluid sack is a high viscosity liquid.

17. The implantable pressure monitor of claim 12, wherein the attachment structure is a strap.

18. The implantable pressure monitor of claim 12, wherein the attachment structure is a suture tab.

19. The implantable pressure monitor of claim 12, wherein the attachment structure is a plurality of suture tabs.

20. The implantable pressure monitor of claim 12, wherein the pressure monitor housing is open on one side to allow the fluid sack to contact a body part.

* * * * *

专利名称(译)	植入式压力监测仪		
公开(公告)号	US20150289772A1	公开(公告)日	2015-10-15
申请号	US14/647705	申请日	2013-11-25
[标]申请(专利权)人(译)	罗彻斯特大学		
申请(专利权)人(译)	罗切斯特大学		
当前申请(专利权)人(译)	罗彻斯特大学		
[标]发明人	HUANG JASON HAITAO DAYAWANSA SAMANTHA		
发明人	HUANG, JASON HAITAO DAYAWANSA, SAMANTHA		
IPC分类号	A61B5/022 A61B5/0235 A61B5/00 A61B5/0215		
CPC分类号	A61B5/02241 A61B5/6883 A61B5/0235 A61B5/02154 A61B5/02255 A61B5/6884		
优先权	61/731742 2012-11-30 US		
其他公开文献	US9993168		
外部链接	Espacenet USPTO		

摘要(译)

提供了一种可植入压力监测器，其具有与患者身体部分接触的流体袋，其中流体袋通过压力监测器壳体保持在身体部分上，该压力监测器壳体可具有各种连接装置。流体袋填充有诸如硅油的液体。压力监测器壳体具有开口，该开口提供通向具有流体阀的瘘管的通路，所述流体阀终止于流体袋。光纤压力传感器通过瘘管和流体阀与流体袋中的液体接触。在本发明的一些实施例中，电子模块与可植入压力监测器结合以提供遥测，电力等。

