



US 20140276124A1

(19) **United States**

(12) **Patent Application Publication**
Cholette et al.

(10) **Pub. No.: US 2014/0276124 A1**
(43) **Pub. Date: Sep. 18, 2014**

(54) **QUANTIFICATION OF RENAL
DENERVATION VIA ALTERATIONS IN
RENAL BLOOD FLOW PRE/POST ABLATION**

A61B 5/0205 (2006.01)
A61B 5/026 (2006.01)
A61B 18/18 (2006.01)

(71) Applicant: **ST. JUDE MEDICAL,
CARDIOLOGY DIVISION, INC.**, St.
Paul, MN (US)

(52) **U.S. Cl.**
CPC *A61B 5/4848* (2013.01); *A61B 5/026*
(2013.01); *A61B 18/18* (2013.01); *A61B*
5/02055 (2013.01); *A61B 5/01* (2013.01);
A61B 5/6858 (2013.01)

(72) Inventors: **Martin Cholette**, Acton, CA (US);
Sergio Shkurovich, Encino, CA (US)

USPC **600/483**; **600/505**

(73) Assignee: **St. Jude Medical, Cardiology Division,
Inc.**, St. Paul, MN (US)

(57) **ABSTRACT**

(21) Appl. No.: **13/836,925**

A renal denervation catheter includes a catheter shaft, at least one ablation member, and a sensor, and is operable to perform a renal denervation procedure. The catheter shaft includes a distal end portion insertable into a renal artery. The at least one ablation member is positioned at the distal end portion of the catheter shaft and operable to ablate renal nerves along a wall of the renal artery. The sensor provides information that correlates to blood flow in the renal artery. A change in blood flow rate in the renal artery resulting from the ablation is indicative of the efficacy of the renal denervation procedure.

(22) Filed: **Mar. 15, 2013**

Publication Classification

(51) **Int. Cl.**
A61B 5/00 (2006.01)
A61B 5/01 (2006.01)

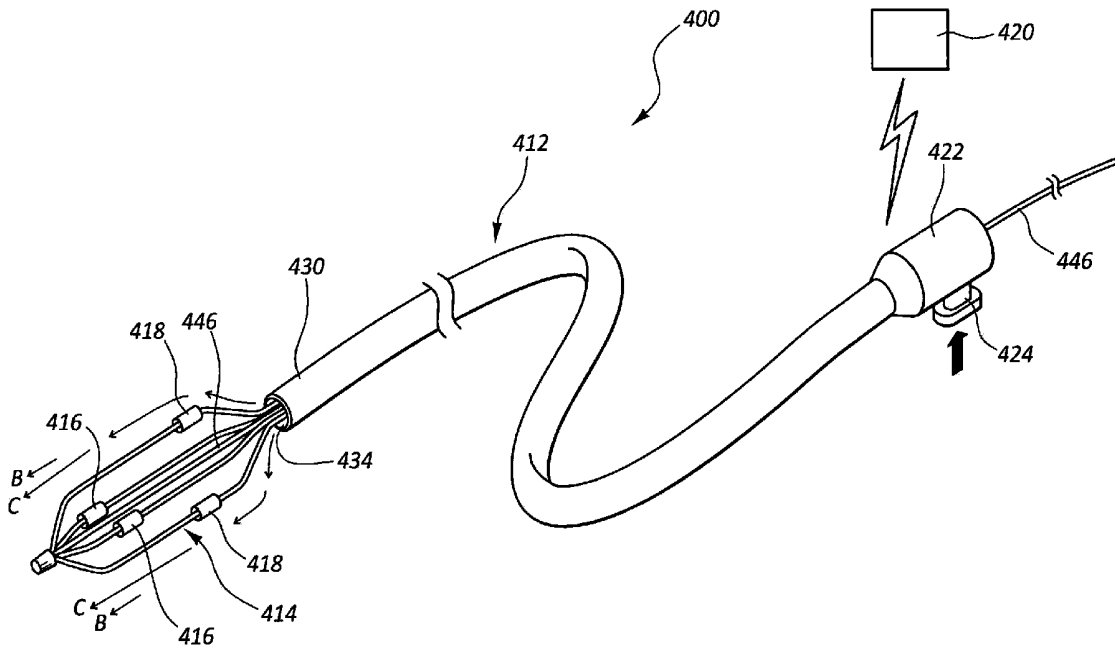

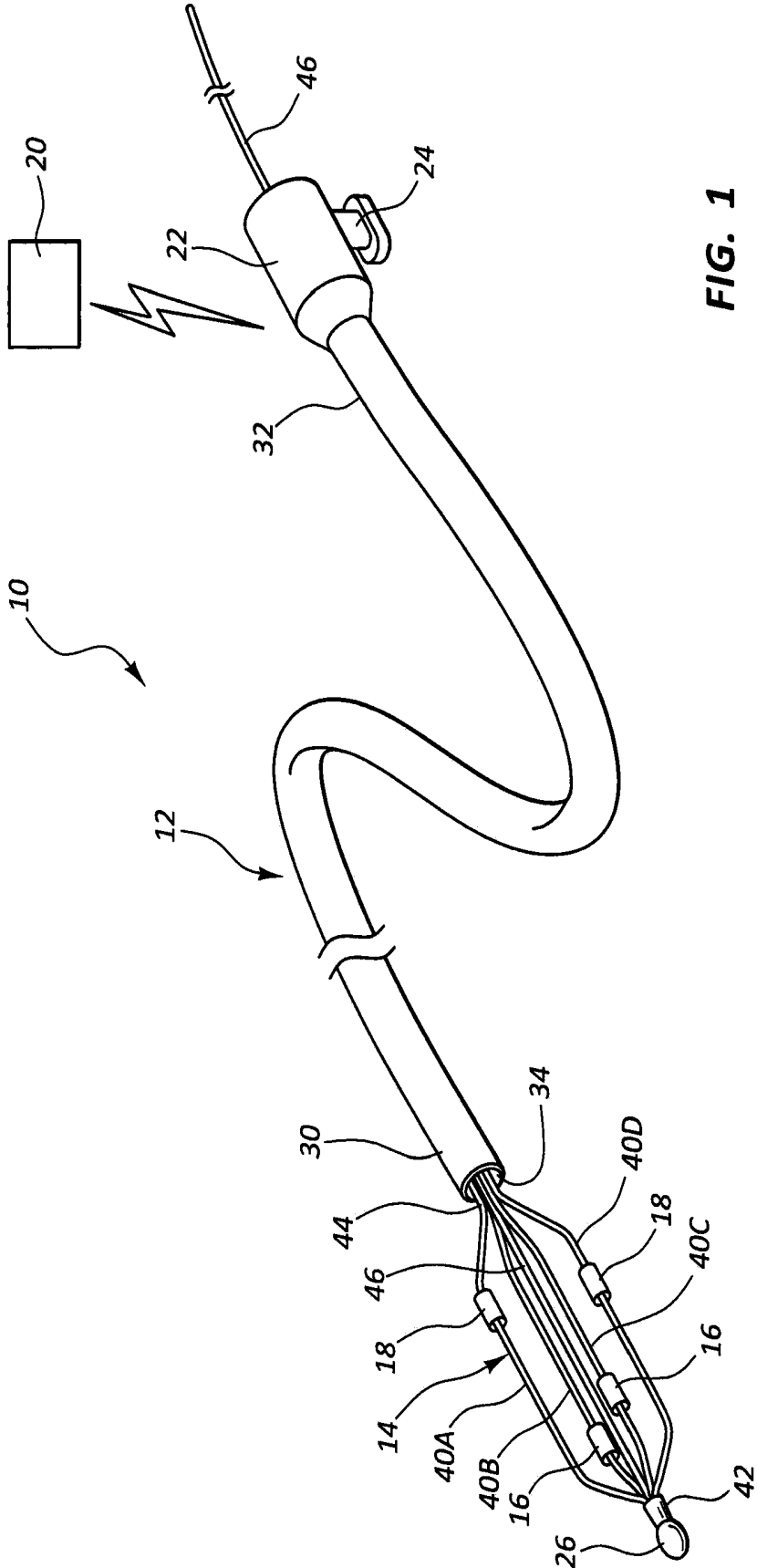

FIG. 1

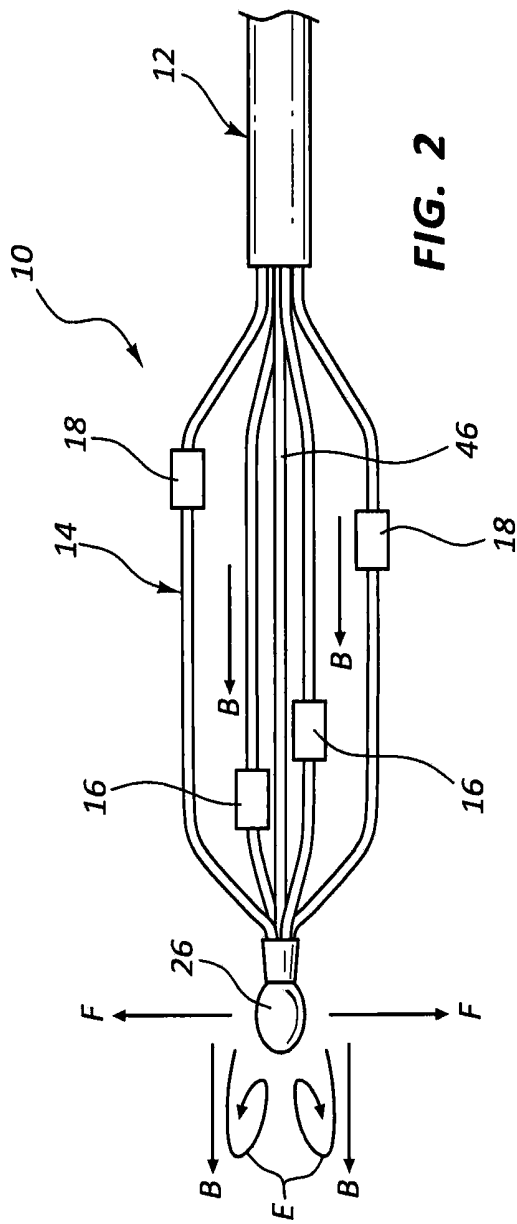

FIG. 2

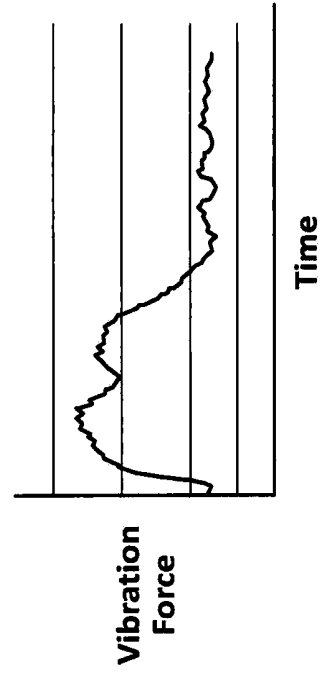

FIG. 3

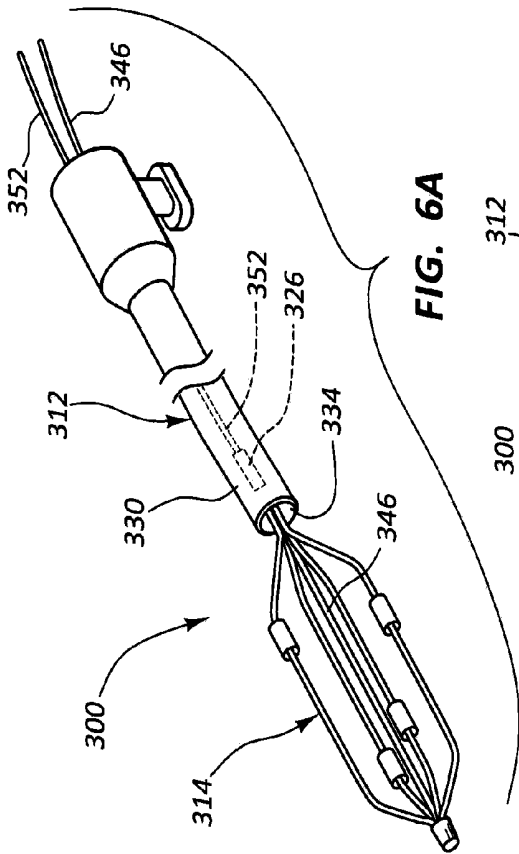

FIG. 6A

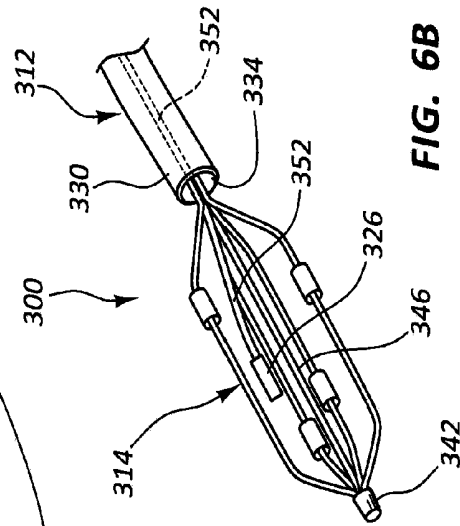

FIG. 6B

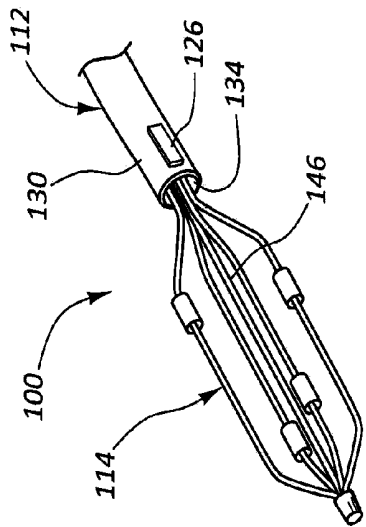

FIG. 4

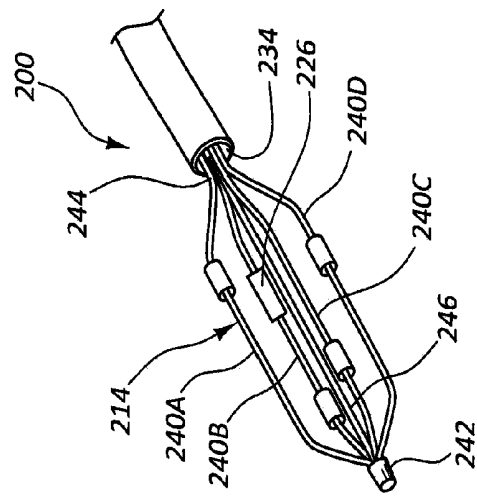

FIG. 5

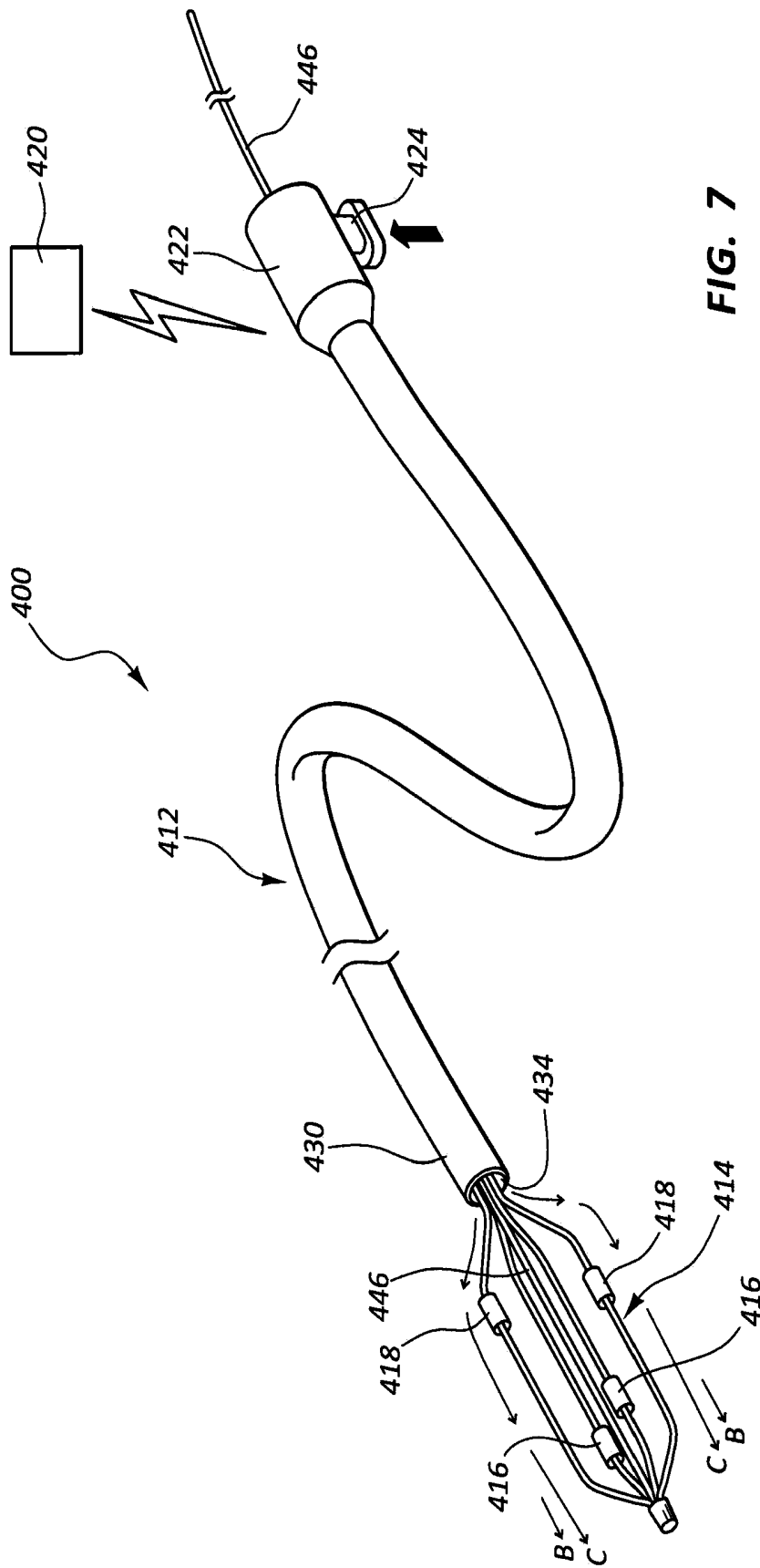

FIG. 7

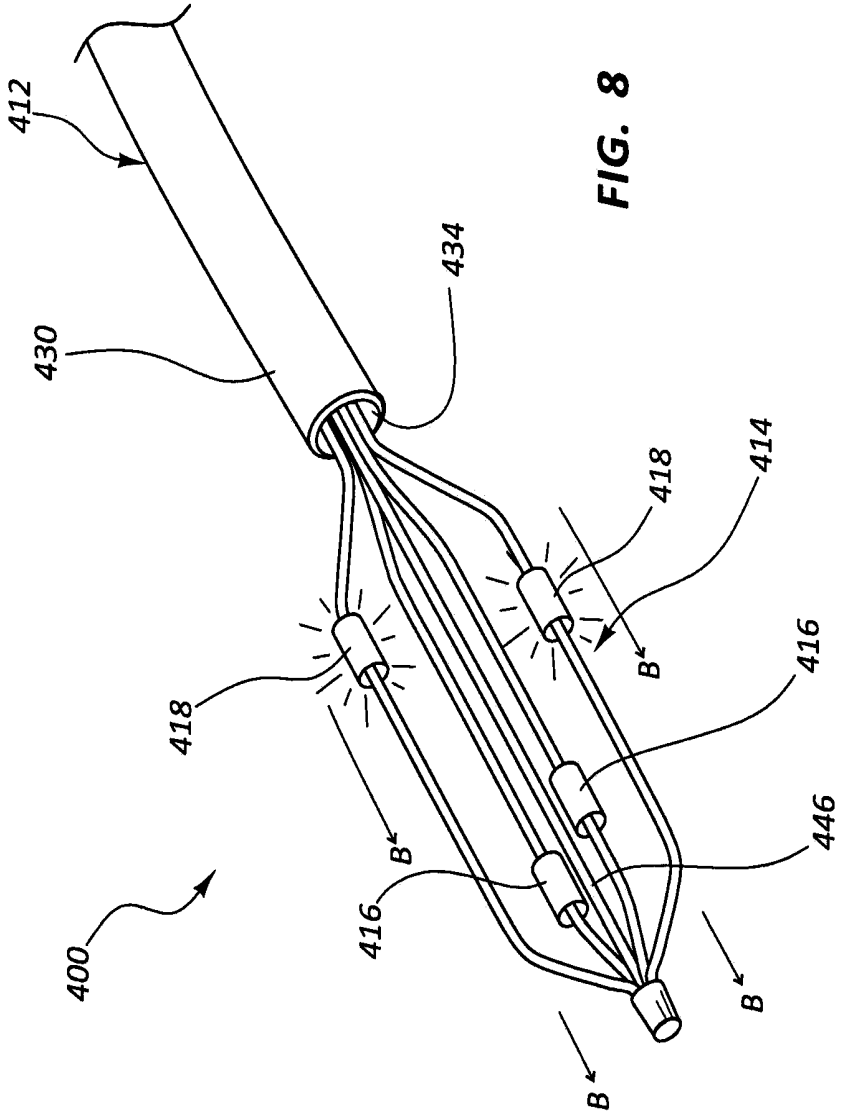

FIG. 8

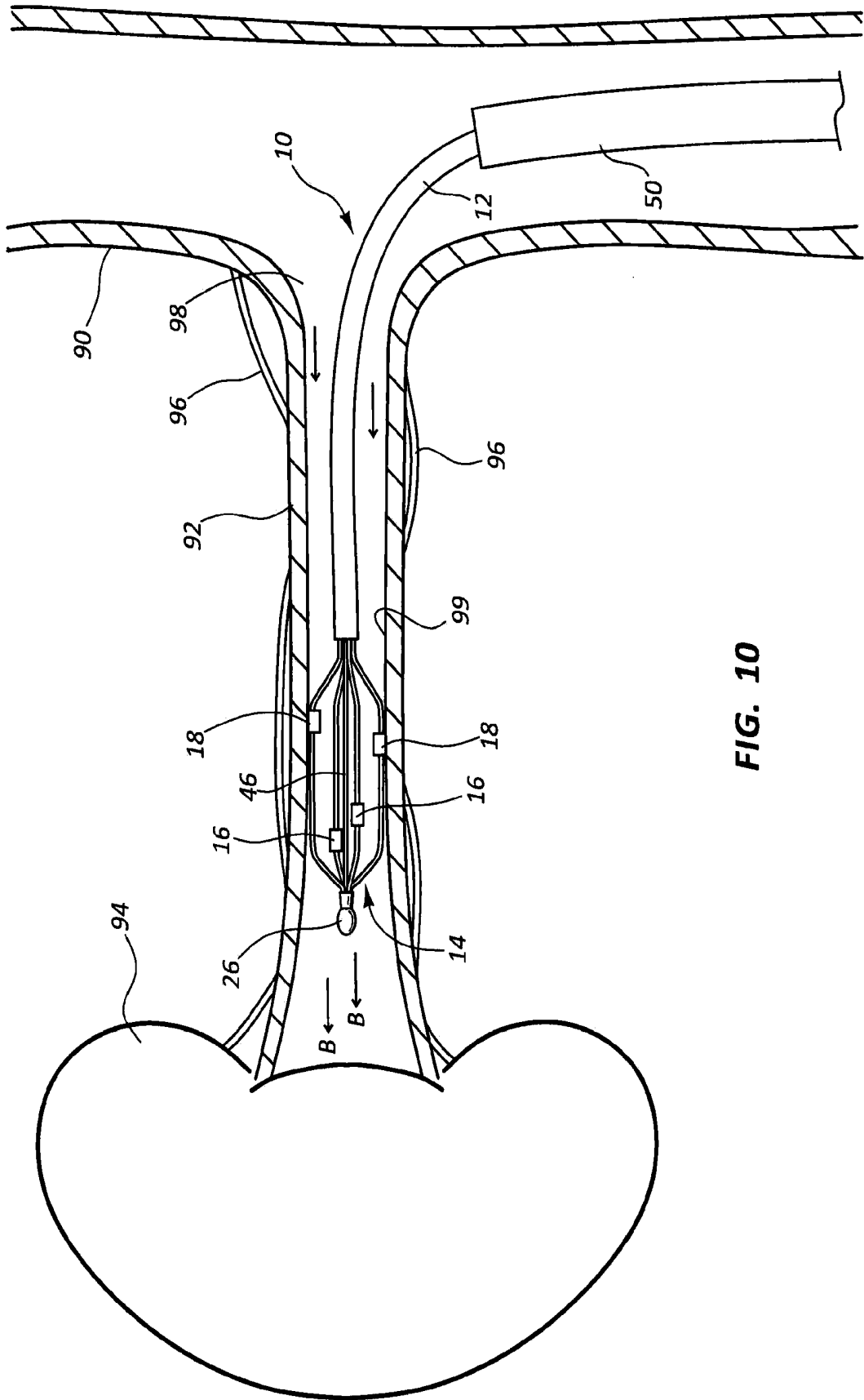

FIG. 10

**QUANTIFICATION OF RENAL
DENERVATION VIA ALTERATIONS IN
RENAL BLOOD FLOW PRE/POST ABLATION**

TECHNICAL FIELD

[0001] The present disclosure relates generally to renal denervation systems and methods, and more particularly, to systems and methods for assessing the efficacy of a renal denervation procedure at the time of the procedure.

BACKGROUND

[0002] Renal denervation is a method whereby amplified sympathetic activities are suppressed. Amplified sympathetic activities and their associated systems are known to contribute to arterial hypertension. Thus, renal denervation is used to treat hypertension or other cardiovascular disorders and chronic renal diseases.

[0003] Renal denervation is achieved through destruction of afferent and efferent nerve fibers that run adjacent to the renal artery. Renal denervation results in lower blood pressure in a patient. Renal denervation has also been shown to have benefits associated with treatment of heart failure, diabetes, obesity, sleep apnea, and ventricular tachycardia (VT). An established renal denervation procedure involves introducing a radiofrequency (RF) ablation catheter, which ablates renal nerves at various locations using variable energy. Presently, there is a need for feedback mechanisms to provide the operator with insight about the efficacy of the renal denervation treatment during the treatment procedure. This feedback would enable the operator to decide whether additional power and/or ablation locations are needed to accomplish adequate renal denervation.

SUMMARY

[0004] One aspect of the present disclosure relates to a renal denervation catheter having a catheter shaft, at least one ablation member, and a vibration sensor. The catheter shaft includes a distal end portion insertable into a renal artery. The at least one ablation member is positioned at the distal end portion of the catheter shaft and operable to ablate renal nerves through a wall of the renal artery. The vibration sensor is configured to measure vibrations in the renal denervation catheter prior to and after operating the at least one ablation member to ablate the renal nerves. A comparison of the measured vibrations is used to determine a change in blood flow rate in the renal artery resulting from the ablation.

[0005] The renal denervation catheter may include a cage structure positioned at the distal end portion of the catheter shaft, wherein the cage structure includes a plurality of radially spaced apart arms, and the at least one ablation member is positioned on at least one of the plurality of radially spaced apart arms. The plurality of radially spaced apart arms may converge at a distal tip, and the vibration sensor may be positioned at the distal tip. The vibration sensor may be positioned proximal of the at least one ablation member. An increase in blood flow rate may correlate with the efficacy of ablating with the at least one ablation member. The vibration sensor may be carried by a wire member insertable through a lumen of the catheter shaft. The at least one ablation member may include one of an ultrasound member and a radio frequency member.

[0006] Another aspect of the present disclosure relates to a method of determining efficacy of a renal denervation procedure

in a renal artery. The method includes providing a renal denervation catheter having at least one ablation member and at least one vibration sensor, operating the at least one ablation member to provide renal denervation in the renal artery, measuring vibrations in the renal denervation catheter prior to and after providing the renal denervation, and comparing the measured vibrations to determine a change in blood flow rate through the renal artery as an indicator of efficacy of the renal denervation.

[0007] The renal denervation catheter may include a cage structure having a plurality of arms, wherein the at least one ablation member is positioned on one of the plurality of arms, and the at least one vibration sensor is positioned distal of the cage structure. The method may include positioning the at least one ablation member in contact with the renal artery prior to operating the at least one ablation member. The method may include correlating the measured vibrations to blood flow rates in the renal artery.

[0008] A further aspect of the present disclosure relates to a renal denervation catheter having a catheter shaft, at least one ablation member, and a temperature monitoring system. The catheter shaft has a distal end portion. The at least one ablation member may be positioned at a distal end portion of the catheter shaft and operable to provide renal denervation in a renal artery. The temperature monitoring system may include at least one temperature sensor and is configured to determine a change in temperature in a blood flow through the renal artery. The change in temperature correlates to a rate of blood flow.

[0009] The temperature monitoring system may include a fluid outlet to deliver a flow of fluid into the blood flow, and the at least one temperature sensor may be positioned downstream of the fluid outlet. The at least one ablation member may be configured to heat the blood flow, and the at least one temperature sensor may be positioned downstream of the at least one ablation member to monitor a temperature change of the blood flow. The temperature monitoring system may include a heating member positioned upstream of the at least one temperature sensor. The at least one ablation member may include one of an ultrasound member and a radio frequency member.

[0010] Another example method in accordance with the present disclosure relates to a method of determining efficacy of a renal denervation procedure in a renal artery. The method includes providing a renal denervation catheter having at least one ablation member and at least one temperature sensor, operating the at least one ablation member to provide denervation of renal nerves in the renal artery, measuring a temperature change in blood flow through the renal artery with the at least one temperature sensor prior to and after the denervation, and comparing the measured temperature changes to determine a change in blood flow rate through the renal artery as an indicator of efficacy of the denervation.

[0011] The method may include changing a temperature of the blood flow upstream of the at least one temperature sensor prior to measuring the temperature change. Changing a temperature of the blood flow may include injecting a flow of fluid having a temperature either above or below a temperature of the blood flow. Changing a temperature of the blood flow may include operating a heating element exposed to the blood flow. The heating element may include the at least one ablation member. The method may include stimulating the renal nerves prior to the denervation.

[0012] The foregoing and other features, utilities, and advantages of the invention will be apparent from the following detailed description of the invention with reference to the accompanying drawings.

BRIEF DESCRIPTION OF THE DRAWINGS

[0013] The accompanying drawings illustrate various embodiments of the present disclosure and are a part of the specification. The illustrated embodiments are merely examples of the present disclosure and do not limit the scope of the invention.

[0014] FIG. 1 is a perspective view of an example renal denervation catheter in accordance with the present disclosure.

[0015] FIG. 2 is a detailed view of a distal end portion of the renal denervation catheter of FIG. 1.

[0016] FIG. 3 is a graph showing change in vibration force in the renal denervation catheter of FIG. 1 in response to change of fluid flow.

[0017] FIG. 4 is a perspective view of a distal end portion of another example embodiment of the renal denervation catheter of FIG. 1.

[0018] FIG. 5 is a perspective view of a distal end portion of another example embodiment of the renal denervation catheter of FIG. 1.

[0019] FIGS. 6A and 6B are perspective views of a distal end portion of another example embodiment of the renal denervation catheter of FIG. 1.

[0020] FIG. 7 is a perspective view of another example renal denervation catheter in accordance with the present disclosure.

[0021] FIG. 8 is a perspective view of a distal end portion of another example embodiment of the renal denervation catheter of FIG. 7.

[0022] FIG. 9 shows the renal denervation catheter of FIG. 1 inserted into a renal artery and arranged to stimulate renal nerves.

[0023] FIG. 10 shows the renal denervation catheter of FIG. 1 positioned within the renal artery and arranged to ablate the renal nerves.

[0024] Throughout the drawings, identical reference numbers designate similar, but not necessarily identical, elements.

DETAILED DESCRIPTION

[0025] The systems and methods disclosed herein are directed to aspects of renal denervation in a patient. The principles disclosed herein may be applicable to other systems and methods used for treating other aspects of the body, including, for example, any portion of the gastrointestinal, cardiovascular, nervous, hormonal, respiratory, excretory and reproductive systems of the body.

[0026] Renal denervation may involve ablation of the renal artery and associated renal nerves using an ablation catheter. While not meant to be limiting, the systems and methods disclosed herein are used to provide feedback to an operator concerning the efficacy of the renal denervation procedure. The feedback may be given during the procedure, such as after ablating the renal artery while the ablation catheter is still positioned within the renal artery.

[0027] The general structure and function of renal denervation catheters used for ablating tissue in the renal artery are known in the art. The principles disclosed herein may be

useful in conjunction with various renal denervation catheters and methods of conducting renal denervation procedures.

[0028] The procedure for renal denervation may be relatively simple. An operator inserts a renal denervation catheter through an artery in the leg, into the aorta, and into the renal artery. In operation, the renal denervation catheter heats the arterial wall. The applied heat kills the renal nerves extending along an exterior and within a sidewall of the artery. The renal nerves typically are distributed in a random pattern along the renal artery. Consequently, the operator typically applies heat at multiple locations along the length of the renal artery and at different circumferential positions in order to have the best chance of ablating as many nerve fibers as needed for effective denervation.

[0029] Ablation may be done using, for example, radio frequency (RF) or ultrasound (US) energy. Other types of energy sources such as, for example, laser, cryothermal, and microwave energy sources may be used. Generally, the intent is to apply as much heat as necessary to kill the nerves, but no more than necessary in order to avoid damaging the renal artery.

[0030] The outcome of renal denervation is to reduce the kidneys' ability to secrete rennin and perform other functions that result in increased blood pressure. When the kidneys are sympathetically activated by the renal nerves, the kidneys secrete more rennin than they should, which leads to more angiotensin in the blood (e.g., resulting in an increase in blood pressure). By killing renal nerves, the renal denervation procedure is able to reduce or eliminate sympathetic activation of the renal nerves, reducing the kidneys' ability to secrete rennin and reducing instances of increased blood pressure.

[0031] An example renal denervation catheter includes a plurality of electrodes positioned circumferentially at different locations and arranged at spaced apart locations along a length of the catheter. In some arrangements, the electrodes may be carried by a basket or a cage structure having a plurality of arms or splines to which the electrodes are mounted. The basket or cage structure may be expandable to position the electrodes in contact with an inner surface of the renal artery. Traditionally, it has been difficult to know at the time of the renal denervation procedure whether sufficient amounts of energy have been applied at an appropriate number of locations to adequately ablate and kill the renal nerves. The present disclosure provides feedback mechanisms for the operator to determine whether sufficient denervation has taken place at the time of the procedure as opposed to waiting days or weeks after the procedure to determine whether sufficient denervation occurred during the procedure.

[0032] One way to provide the desired feedback is to stimulate the renal nerves prior to performing the ablation procedure, measure kidney functions, perform the ablation, stimulate the nerves after the ablation procedure, and measure kidney functions after the second stimulation. In one example, the stimulation may occur at a location adjacent to the ostium of the renal artery where the renal artery bifurcates from the aorta. The stimulation may be performed using the electrodes which are later used to ablate the renal nerves. The stimulation may be applied at several axial and circumferential positions in the renal artery to increase the reliability of the stimulation (e.g., aligning one or more electrode is proximity to one or more nerves in order to effectively stimulate the nerve). Ablation may occur at separate locations along the length of the renal artery from where stimulation is provided. Ablation may be applied at multiple circumferential and axial

positions in the renal artery. The electrodes may be repositioned a plurality of times within the renal artery to provide the desired stimulations and ablations. Multiple series of stimulating, measuring and ablating may be used to confirm efficacy of the denervation procedure. Further, there may not be direct communication between any specific electrodes during, for example, any of the stimulations performed.

[0033] One measurable output of the kidneys resulting from the stimulation is a decrease in glomerular filtration rate (GFR), which decreases the renal blood flow (e.g., decreases the amount of blood that is flowing through the renal artery). The flow rate through the renal artery may be determined using at least one of, for example, vibrations and thermomodulation, which will be described in further detail below.

[0034] By monitoring the change in rate of blood flow through the renal artery using the example blood flow measuring procedures discussed herein (e.g., vibration and thermomodulation) an operator is able to indirectly determine whether the renal denervation procedure was successful while the renal denervation catheter remains positioned within the renal artery. In accordance with the present disclosure, a measurable change in renal blood flow will result in response to a successful renal denervation procedure. By determining whether an appropriate change in blood flow has occurred using the exemplary techniques disclosed herein, the system may provide real-time feedback or at least feedback within the time frame of a renal denervation procedure, as to the efficacy of the renal denervation procedure. Using techniques for determining rates of flow through a conduit (e.g., vibration and thermomodulation), desired feedback concerning the efficacy of the renal denervation procedure may be provided, as will be described in further detail below.

[0035] Referring now to FIGS. 1-3, an example renal denervation catheter 10 is shown and described in detail. The renal denervation catheter 10 includes a catheter shaft 12, a deployable basket 14, distal and proximal electrodes 16, 18, a controller 20, and a hub 22. A vibration sensor 26 may be positioned, for example, at a distal end of the deployable basket 14.

[0036] The catheter shaft 12 may include distal and proximal ends 30, 32 and a lumen 34. The deployable basket 14 may include a plurality of splines or arm members 40A-40D, distal and proximal ends 42, 44, and a pull wire 46. Operating the pull wire 46 may move the deployable basket 14 from a retracted position to a deployed or expanded position, as shown in FIGS. 1 and 2. The deployable basket 14 in the expanded position shown in FIGS. 1 and 2 may position the ablation electrodes 16, 18 in direct contact with an inner surface of a renal artery. A separate one of the splines 40A-40D may support at least one of the ablation electrodes 16, 18. In other arrangements, multiple electrodes may be positioned on a single spline. Alternatively, additional splines beyond the number of ablation electrodes 16, 18 may be used.

[0037] The controller 20 may control operation of the ablation electrodes 16, 18 and the vibration sensor 26. The controller 20 may receive feedback from the ablation electrodes 16, 18 and vibration sensor 26 as part of determining efficacy of a renal denervation procedure (e.g., determining a change in blood flow through the renal artery). The controller 20 may be directly wired to the ablation electrodes 16, 18 and vibration sensor 26. Alternatively, the controller 20 may have wireless communications with various sensors and electronic components of the renal denervation catheter 10.

[0038] The pull wire 46 may extend through the lumen 34 of the catheter shaft 12. A proximal portion of the pull wire 46 may be accessible by an operator to actuate the deployable basket 14 between the retracted and expanded positions.

[0039] The vibration sensor 26 may be positioned at the distal end 42 of the deployable basket 14. The vibration sensor 26 may provide an output signal related to vibration force. The output signal may be plotted over time as shown in the graph of FIG. 3. FIG. 3 shows a reduction in vibration force after the flow rate is reduced. The vibrations may be induced in the vibration sensor 26 from blood flow around the vibration sensor 26. As blood circulates through the deployable basket 14, the flow is distributed and becomes turbulent around the tip of the deployable basket 14. The vibrations are related to the speed of the blood, and thus the blood flow rate. Equations correlating vibrations induced in a structure positioned in a flow of fluid are described in Brevins, R. D., "Vibration of Structures Induced by Blood Flow," chapter 29, part 1, 2d ed., Kreiger, Malibar, Fla., 1994, 13, which is incorporated herein in its entirety by this reference.

[0040] An equation for determining vibration induced force (F) provided by Brevins is as follows:

$$F = \frac{1}{2} \rho U^2 C_L D L J \sin(2\pi f_s t) \quad (\text{Equation 1})$$

[0041] Where: ρ =fluid density

[0042] U=fluid velocity

[0043] C_L =lift coefficient (a function of Reynolds number and cylindrical motion)

[0044] D=diameter

[0045] L=length of cylinder

[0046] J=joint acceptance

[0047] f_s =frequency of alternating lift force

[0048] t=time

[0049] and joint acceptance (J) is determined as follows:

[0050] J=1 (if fully correlated along entire length L)

[0051] $J = (l_c/L)^{1/2}$ (if l_c (spanwise correlation length) $\ll L$)

[0052] FIG. 2 shows a blood flow B moving through the deployable basket 14 and around the vibration sensor 26. Positioning the renal denervation catheter 10 within blood flow through the renal artery may create turbulence in the blood flow B. The turbulence may be evidenced by eddy currents E downstream of the vibration sensor 26. The vibration forces F may occur in a plurality of direction such as in a lateral direction shown in FIG. 2. Providing at least some asymmetrical features on the renal denervation catheter 10 may induce additional turbulence that may be more easily measured by the vibration sensor 26. Some asymmetrical features include, for example, positioning of the ablation electrodes 16, 18 at various circumferential and axial positions along the deployable basket 14. Alternatively, varying the shape, size and orientation of the splines 40A-40D may create additional asymmetry.

[0053] The vibration sensor 26 may be located at various locations on the renal denervation catheter. For example, FIG. 4 shows a vibration sensor 126 positioned on a catheter shaft 112 at a location proximal of a deployable basket 114 of a renal denervation catheter 100. The vibration sensor 126 may be positioned at a distal end portion 130 of the catheter shaft 112, which may be operated using a pull wire 146. The vibration sensor 126 may be positioned on an outer circumferential surface of the catheter shaft 112. Alternatively, the vibration sensor 126 may be positioned internally within a lumen 134 of the catheter shaft 112.

[0054] FIG. 5 shows another example renal denervation catheter 200 having a vibration sensor 226 mounted to one of the splines 240A-240D of a deployable basket 214. The deployable basket 214 may be operated using a pull wire 246. The vibration sensor 226 may be positioned at an axial location space between the distal and proximal ends 242, 244 of the deployable basket 214. In at least one example, the sensor measurements taken by vibration sensor 226 may occur prior to expansion of the deployable basket 214 into the expanded position shown in FIG. 5 to avoid contact with the inner surface of the renal artery which may otherwise affect operation of the vibration sensor 226. Alternatively, the deployable basket 214 may be operated into the expanded position shown in FIG. 5 prior to taking the vibration measurements of vibration sensor 226. In another embodiment, the vibration sensor 226 may be mounted to the pull wire 246 used to operate the deployable basket 214 between expanded and retracted positions.

[0055] In an alternative arrangement, a vibration sensor 326 may be mounted to a separate carrier wire 352 as shown in FIGS. 6A and 6B. The carrier wire 352 may position the vibration sensor 326 within a lumen 334 of a catheter shaft 312 as shown in FIG. 6A. In one example, the vibration sensor 326 is positioned adjacent to a distal end 330 of the catheter shaft 312. The carrier wire 352 may position the vibration sensor 326 proximal of a deployable basket 314. The deployable basket 314 may be operated using the pull wire 346.

[0056] FIG. 6B shows the carrier wire 352 advanced distally to position the vibration sensor 326 outside of the catheter shaft 312. The vibration sensor 326 may be positioned radially inward from the splines of the deployable basket 314. In other arrangements, the carrier wire 352 may be advanced further distally to position the vibration sensor 326 distal of the deployable basket 314. The carrier wire 352 may be a commercially available product such as the PressureWire™ Certus available from St. Jude Medical of St. Paul, Minn.

[0057] Referring now to FIGS. 7 and 8, thermodilution techniques are described as an alternative option for determining change of blood flow through a renal artery. Thermodilution may be adapted to measure blood flow in the renal artery using the heating electrodes and thermistors present on the renal denervation catheter, or provide injection of cold saline through a dedicated port in the renal denervation catheter along with using the thermistors for a temperature gradient measurement. The thermodilution techniques may have the additional advantage of providing a status of renal blood flow pre-ablation (e.g., without first providing electrical stimulation to the renal nerves) and comparing the pre-ablation flow with post-ablation flow to determine whether the ablation procedure altered renal blood flow.

[0058] FIG. 7 shows a renal denervation catheter 400 having a catheter shaft 412, a deployable basket 414, distal and proximal ablation electrodes 416, 418, a controller 420, and a hub 422 having a fluid port 424. The catheter shaft 412 may include a lumen 434 dedicated to delivery of a saline or other liquid provided at a predetermined temperature. The lumen 434 may be used for delivery of a pull wire 446, which is used to operate the deployable basket 414. The saline is delivered into the lumen 434 via the fluid port 424 and ejected at a distal end 430 of catheter shaft 412 as a fluid flow C. The fluid flow C mixes with the blood flow B. At least one of the distal and proximal electrodes 416, 418 includes a thermistor configured to monitor the temperature of fluid flow around the electrode. Typically, a profile of temperature monitored by

the thermistor of the distal and proximal electrodes 416, 418 is proportional to the rate of blood flow. Thus, based on the temperature profile, a calculation may be made of the blood flow needed to dilute the temperature from the temperature of the injected saline to a level sensed by the thermistor. Typically, the temperature of the injected saline and the distance downstream of the thermistor from the point of injecting the saline into the blood flow are used to provide an accurate calculation.

[0059] A number of known methods have been used to determine cardiac output using saline thermodilution as discussed above. Some examples of such known methods are discussed in Haller, et al., "Evaluation of a new continuous thermodilution cardiac output monitor in critically ill patients: a prospective criterion standard study," *Critical Care Medicine*, May 1995, 23(5):860-6, which is incorporated herein in its entirety by this reference.

[0060] Another example thermodilution technique is described with reference to FIG. 8. In FIG. 8, the renal denervation catheter 400 provides heating of the blood flow B using a heating element of at least one of the proximal electrodes 418. A thermistor of at least one of the distal electrodes 416 may be used to monitor a temperature of the blood flow B. The system of FIG. 8 provides changing a temperature of the blood flow using at least one of the electrodes instead of changing of the temperature of the blood flow by injecting a cold fluid as described above with reference to FIG. 7. In one example, both of the proximal electrodes 418 are used to heat the blood flow B, and both of the distal electrodes 416 are used to measure the temperature of the blood B. Inputs used for determining the change of blood flow prior to and after a renal denervation procedure in which the renal nerves are ablated may include an amount of heat generated by the proximal electrodes 418 (e.g., during operation at a predetermined setting), a change in temperature of the blood flow B over time, and a separation distance between the distal and proximal electrodes 416, 418.

[0061] Typically, each of the distal and proximal electrodes 416, 418 of the renal denervation catheter 400 include a heating element and a thermistor. The heating element and thermistor may be included as part of an ablation electrode such that the operator may have real-time feedback concerning the temperature of the heating element to avoid application of excessive heat to the tissue of the renal artery.

[0062] Each of the renal denervation catheters 10, 100, 200, 300, 400 described above with reference to FIGS. 1-8 may operate to determine change of blood flow prior to, during, and after an ablation procedure in which renal nerves associated with the renal vessel are ablated or killed. In some examples, it is possible for the blood flow rate to change abruptly at some point during the ablation procedure when enough of the nerve fibers are killed. The devices and methods disclosed herein may provide feedback concerning change in blood flow rate independent of electrical stimulation of the renal nerves prior to, during and after a renal denervation procedure.

[0063] Referring now to FIGS. 9 and 10, an example method of renal denervation is described. FIG. 9 shows a renal denervation catheter 10 advanced through an introducer 50 and into a renal artery 92. The renal denervation catheter 10 extends through an ostium 98 where the renal artery 92 branches from the aorta 90. The deployable basket 14 is positioned within the renal artery 92 adjacent to the ostium 98. The deployable basket 14 is operated into an expanded

position to contact the ablation electrodes **16, 18** with an inner surface **99** of the renal artery **92**. The ablation electrodes **16, 18** are operated to provide electrical stimulation of a plurality of renal nerves **96** positioned within and along an exterior of the renal artery **92**. The electrical stimulation may create a response from kidney **94** in the form of, for example, an increase or decrease of rennin production.

[0064] After stimulating the renal nerves, the renal denervation catheter **10** may be further advanced into a position in the renal artery **92** spaced distally from the ostium **98**, as shown in FIG. **10**. The vibration sensor **26** may be used to determine vibration forces in the renal denervation catheter **10**. The vibration forces may be correlated to a rate of blood flow **B** in the renal artery **92**.

[0065] The renal denervation catheter **10** may then be operated to ablate the renal nerves **96** by producing heat with the ablation electrodes **16, 18**. The amount of heat generated by the ablation electrodes **16, 18** may depend on a number of factors including, for example, the number and location of the ablation electrodes **16, 18**, a position within the renal artery **92**, and the size of the renal artery **92**.

[0066] The vibration sensor **26** may be used again to determine the rate of blood flow **B**. The system may provide a comparison of the rate of blood flow **B** before and after the ablation. If the change in blood flow exceeds a certain threshold amount or the absolute value of the blood flow reaches a predetermined level, the ablation may be considered successful. If more ablation is needed, the ablation electrodes **16, 18** may be operated repeatedly to produce more heat to ablate the renal nerves **96**.

[0067] In a further treatment step, the renal denervation catheter **10** may be moved proximally to reposition the deployable basket **14** at the ostium **98** as shown in FIG. **9**. The renal nerves **96** may be electrically stimulated a second time using, for example, at least one of the ablation electrodes **16, 18** as described above with reference to FIG. **9**. The electrical stimulation may generate a response in the kidney **94**, such as an increase or decrease in rennin production. If the ablation procedure described with reference to FIG. **10** was efficacious, the second electrical stimulation may create little or no response in the kidney **94**. The renal denervation catheter **10** may be withdrawn from the renal artery **92** if the renal denervation procedure is determined to be complete.

[0068] In some examples, the renal denervation catheter **10** may maintain a constant position while stimulating the renal nerves prior to ablation, measuring blood flow prior to ablation, ablating the renal nerves, stimulating the renal nerves after ablation, and measuring blood flow after the second stimulation. Furthermore, a predetermined time delay may be used between each of the stimulation, ablation, and flow determination steps described above with reference to FIGS. **9** and **10**. The deployable basket **14** may be moved between expanded and retracted positions between each of the stimulation, ablation, and flow rate determination steps, and between moving the renal denervation catheter **10** between various axial positions (e.g., as shown in FIGS. **9** and **10**).

[0069] In other examples, the denervation methods described with reference to the figures may be done without the steps of stimulating the renal nerves **96** before or after measuring the blood flow using vibration sensor **26**, measuring blood flow via a change in blood flow temperature using the ablation electrodes **16, 18**, and ablating the renal nerves **96** with the ablation electrodes **16, 18**.

[0070] An example method of determining the efficacy of a renal denervation procedure in a renal artery may include providing a renal denervation catheter having at least one ablation member and at least one vibration sensor. The at least one ablation member may be operated to provide renal denervation in the renal artery (e.g., ablating renal nerves through the sidewall of the renal artery). The renal denervation catheter may measure vibrations induced by blood flow through the renal artery. The vibrations may correlate to a rate of blood flow through the renal artery. The blood flow prior to and after operating the ablation member to provide renal denervation may be compared to determine whether sufficient ablation has occurred to denervate the renal nerves of the renal artery.

[0071] The vibrations may be measured using a vibration sensor positioned at any desired location along a length of the renal denervation catheter. For example, the vibration sensor may be positioned at a distal most tip of the renal denervation catheter. In other examples, the vibration sensor may be positioned along a deployable basket of the renal denervation catheter, along a catheter shaft at a location proximal of the deployable basket, or on a separate carrier wire moveable independent of the catheter shaft and the deployable basket.

[0072] Another example method of determining efficacy of a renal denervation procedure in a renal artery includes providing a renal denervation catheter having at least one ablation member and at least one temperature sensor. The method includes determining a temperature change in the blood flow prior to and after operating the at least one ablation member to ablate renal nerves associated with the renal artery. The temperature changes are correlated to a blood flow rate through the renal artery. The blood flow rates are used as an indicator of efficacy of the denervation procedure.

[0073] The temperature of the blood flow may be changed prior to or after the ablation procedure by supplying a flow of cold saline at a location upstream of at least some of the ablation members. In another example, at least some of the ablation members themselves are used to heat the blood flow and others of the ablation members include a temperature sensor (e.g., a thermistor) to measure a temperature of the blood flow. These and other methods may be used in accordance with the disclosure provided herein.

[0074] Generally, the systems and methods disclosed herein may provide feedback to an operator concerning the efficacy of a renal denervation procedure using changes in blood flow through the renal artery. The change in blood flow may be determined using a comparison of blood flow rates measured before and after ablating the renal artery and associated renal nerves. The change in blood flow may be determined using an absolute change in blood flow rate associated with ablating the renal artery.

[0075] As used in this specification and the appended claims, the terms “engage” and “engagable” are used broadly to mean interlock, mesh, or contact between two structures or devices. A “tube” is an elongated device with a passageway. The passageway may be enclosed or open (e.g., a trough). A “lumen” refers to any open space or cavity in a bodily organ, especially in a blood vessel. The words “including” and “having,” as well as their derivatives, as used in the specification, including the claims, have the same meaning as the word “comprising.”

[0076] The preceding description has been presented only to illustrate and describe exemplary embodiments of the invention. It is not intended to be exhaustive or to limit the invention to any precise form disclosed. Many modifications

and variations are possible in light of the above teaching. It is intended that the scope of the invention be defined by the following claims.

What is claimed is:

1. A renal denervation catheter, comprising:
a catheter shaft having a distal end portion insertable into a renal artery;
at least one ablation member positioned at the distal end portion of the catheter shaft and operable to ablate renal nerves along a wall of the renal artery;
a vibration sensor configured to measure vibrations in the renal denervation catheter prior to and after operating the at least one ablation member to ablate the renal nerves, wherein a comparison of the measured vibrations is used to determine a change in blood flow rate in the renal artery resulting from the ablation.
2. The renal denervation catheter of claim 1, further comprising a cage structure positioned at the distal end portion of the catheter shaft, the cage structure comprising a plurality of radially spaced apart arms, the at least one ablation member being positioned on at least one of the plurality of radially spaced apart arms.
3. The renal denervation catheter of claim 2, wherein the plurality of radially spaced apart arms converge at a distal tip, and the vibration sensor is positioned at the distal tip.
4. The renal denervation catheter of claim 1, wherein the vibration sensor is positioned proximal of the at least one ablation member.
5. The renal denervation catheter of claim 1, wherein an increase in blood flow rate correlates with efficacy of the ablation.
6. The renal denervation catheter of claim 1, wherein the vibration sensor is carried by a wire member insertable through a lumen of the catheter shaft.
7. The renal denervation catheter of claim 1, wherein the at least one ablation member comprises one of an ultrasound member and a radio frequency member.
8. A method of determining efficacy of a renal denervation procedure in a renal artery, comprising:
providing a renal denervation catheter having at least one ablation member and at least one vibration sensor;
operating the at least one ablation member to provide renal denervation in the renal artery;
measuring vibrations in the renal denervation catheter prior to and after providing the renal denervation;
comparing the measured vibrations to determine a change in blood flow rate through the renal artery as an indicator of efficacy of the renal denervation.
9. The method of claim 8, wherein the renal denervation catheter comprises a cage structure having a plurality of arms, the at least one ablation member being positioned on one of the plurality of arms, and the at least one vibration sensor being positioned distal of the cage structure.
10. The method of claim 8, further comprising positioning the at least one ablation member in contact with the renal artery prior to operating the at least one ablation member.
11. The method of claim 8, further comprising correlating the measured vibrations to blood flow rates in the renal artery.

12. A renal denervation catheter, comprising:
a catheter shaft having a distal end portion;
at least one ablation member positioned at a distal end portion of the catheter shaft and operable to provide renal denervation in a renal artery;
a temperature monitoring system having at least one temperature sensor and configured to determine a change in temperature in a blood flow through the renal artery, the change in temperature correlating to a rate of blood flow.
13. The renal denervation catheter of claim 12, wherein the temperature monitoring system comprises a fluid outlet to deliver a flow of fluid into the blood flow, and the at least one temperature sensor is positioned downstream of the fluid outlet.
14. The renal denervation catheter of claim 12, wherein the at least one ablation member is configured to heat the blood flow, and the at least one temperature sensor is positioned downstream of the at least one ablation member to monitor a temperature change of the blood flow.
15. The renal denervation catheter of claim 12, wherein the temperature monitoring system comprises a heating member positioned upstream of the at least one temperature sensor.
16. The renal denervation catheter of claim 12, wherein the at least one ablation member comprises one of an ultrasound member and a radio frequency member.
17. A method of determining efficacy of a renal denervation procedure in a renal artery, comprising:
providing a renal denervation catheter having at least one ablation member and at least one temperature sensor;
operating the at least one ablation member to provide denervation of renal nerves along the renal artery;
measuring a temperature change in blood flow through the renal artery with the at least one temperature sensor prior to and after the denervation;
comparing the measured temperature changes to determine a change in blood flow rate through the renal artery as an indicator of efficacy of the denervation.
18. The method of claim 17, further comprising changing a temperature of the blood flow upstream of the at least one temperature sensor prior to measuring the temperature change.
19. The method of claim 18, wherein changing a temperature of the blood flow includes injecting a flow of fluid having a temperature either above or below a temperature of the blood flow.
20. The method of claim 18, wherein changing a temperature of the blood flow includes operating a heating element exposed to the blood flow.
21. The method of claim 20, wherein the heating element comprises the at least one ablation member.
22. The method of claim 17, further comprising stimulating the renal nerves prior to the denervation.

* * * * *

专利名称(译)	通过消融前/后肾血流改变量化肾去神经支配		
公开(公告)号	US20140276124A1	公开(公告)日	2014-09-18
申请号	US13/836925	申请日	2013-03-15
[标]申请(专利权)人(译)	圣犹达医疗用品心脏病学部门有限公司		
申请(专利权)人(译)	ST.犹达医疗用品, 心脏病DIVISION, INC.		
当前申请(专利权)人(译)	ST.犹达医疗用品, 心脏病DIVISION, INC.		
[标]发明人	CHOLETTE MARTIN SHKUROVICH SERGIO		
发明人	CHOLETTE, MARTIN SHKUROVICH, SERGIO		
IPC分类号	A61B5/01 A61B18/18 A61B5/00 A61B5/026 A61B5/0205		
CPC分类号	A61B5/4848 A61B18/18 A61B5/6858 A61B5/02055 A61B5/026 A61B5/01 A61B18/1492 A61B2018/00863 A61B2018/00434 A61B2018/00511 A61B2018/00744 A61B2018/00577 A61B2018/00714 A61B2218/002 A61N7/00 A61B2018/00642 A61B2018/00404 A61B2018/00791 A61B2018/0088 A61B5/201 A61N7/022 A61B2018/00267		
其他公开文献	US9974477		
外部链接	Espacenet USPTO		

摘要(译)

肾去神经支配导管包括导管轴, 至少一个消融构件和传感器, 并且可操作以执行肾去神经支配术。导管轴包括可插入肾动脉的远端部分。所述至少一个消融构件定位在导管轴的远端部分处并且可操作以沿着肾动脉的壁消融肾神经。传感器提供与肾动脉中的血流相关的信息。由消融引起的肾动脉中的血流速率的变化指示肾去神经支配程序的功效。

