



US010426658B2

(12) **United States Patent**  
**Maher**

(10) **Patent No.:** **US 10,426,658 B2**  
(45) **Date of Patent:** **\*Oct. 1, 2019**

(54) **CERVICAL COLLAR**

5/4836 (2013.01); A61B 5/6822 (2013.01);  
A61F 7/106 (2013.01); A61F 2007/0009  
(2013.01); A61F 2007/0011 (2013.01); A61F  
2007/0056 (2013.01); A61F 2007/0086  
(2013.01); A61F 2007/0095 (2013.01); A61F  
2007/0225 (2013.01);

(71) Applicant: **Robert Michael Maher**, Columbus,  
OH (US)

(72) Inventor: **Robert Michael Maher**, Columbus,  
OH (US)

(73) Assignee: **NeuroRescue, LLC**, New Albany, OH  
(US)

(\* ) Notice: Subject to any disclaimer, the term of this  
patent is extended or adjusted under 35  
U.S.C. 154(b) by 440 days.

This patent is subject to a terminal dis-  
claimer.

(21) Appl. No.: **15/287,227**

(22) Filed: **Oct. 6, 2016**

(65) **Prior Publication Data**

US 2017/0020722 A1 Jan. 26, 2017

**Related U.S. Application Data**

(63) Continuation-in-part of application No. 14/052,346,  
filed on Oct. 11, 2013, now Pat. No. 9,486,354, which  
is a continuation-in-part of application No.  
13/309,173, filed on Dec. 1, 2011, now abandoned.

(60) Provisional application No. 61/419,018, filed on Dec.  
2, 2010.

(51) **Int. Cl.**

**A61B 5/01** (2006.01)  
**A61F 7/02** (2006.01)  
**A61F 5/055** (2006.01)  
**A61F 7/10** (2006.01)

(Continued)

(52) **U.S. Cl.**

CPC ..... **A61F 7/02** (2013.01); **A61B 5/01**  
(2013.01); **A61B 5/6812** (2013.01); **A61F**  
**5/055** (2013.01); **A61F 7/10** (2013.01); **A61B**

(58) **Field of Classification Search**

CPC ..... A61F 7/0085  
USPC ..... 602/14, 5, 1, 2, 18, 41, 60, 61; 607/109,  
607/108, 96, 1, 104, 105

See application file for complete search history.

(56) **References Cited**

**U.S. PATENT DOCUMENTS**

2,250,840 A 7/1941 Pomeranz  
4,745,922 A 5/1988 Taylor  
4,821,354 A 4/1989 Little

(Continued)

**OTHER PUBLICATIONS**

International Search Report for International Patent Application No.  
PCT/US2011/063021 dated Mar. 9, 2012, 2 pages.

(Continued)

*Primary Examiner* — Tarla R Patel

(74) *Attorney, Agent, or Firm* — Walter Haverfield LLP;  
James J. Pingor

(57) **ABSTRACT**

A cervical collar that facilitates therapeutic hypothermia is  
provided and includes an outer shell having a front portion  
and a back portion fixedly coupled to the front portion on  
one side and removably coupled to the front portion on an  
opposite side. A fastening device removably couples the  
back portion to the front portion on the opposite side. At  
least one cooling device is provided on an interior of the  
outer shell to induce hypothermia in a patient. A sensor is  
provided that measures a physical characteristic of the  
patient.

**20 Claims, 14 Drawing Sheets**

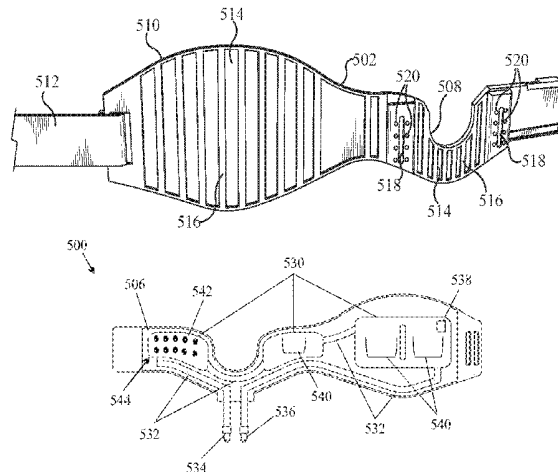

(51)	<b>Int. Cl.</b> <i>A61B 5/00</i> (2006.01) <i>A61F 7/00</i> (2006.01)	7,846,118 B2 12/2010 Sandhu 7,861,326 B2* 1/2011 Harty ..... A41D 13/0512 2/468
(52)	<b>U.S. Cl.</b> CPC ..... <i>A61F 2007/0228</i> (2013.01); <i>A61F 2007/0231</i> (2013.01); <i>A61F 2007/0282</i> (2013.01)	2003/0236561 A1 12/2003 Lennox 2005/0284416 A1* 12/2005 Smit ..... A01K 13/006 119/850 2006/0079820 A1* 4/2006 Sandhu ..... A61F 5/055 602/18 2008/0269852 A1* 10/2008 Lennox ..... A61F 7/02 607/104 2010/0305669 A1 12/2010 Sasaki 2011/0054577 A1 3/2011 Latham 2013/0030341 A1* 1/2013 Freer ..... A61F 13/0233 602/43 2014/0128945 A1* 5/2014 Schoning ..... A61F 7/106 607/109
(56)	<b>References Cited</b>  U.S. PATENT DOCUMENTS  4,886,063 A 12/1989 Crews 5,038,759 A 8/1991 Morgenstern 5,072,875 A* 12/1991 Zaco ..... A61F 7/02 607/104  5,211,623 A 5/1993 Sarkozy 5,415,624 A 5/1995 Williams 5,449,379 A 9/1995 Hadtke 5,871,526 A* 2/1999 Gibbs ..... A61F 7/02 165/46 6,152,953 A* 11/2000 Hipkind ..... A61F 7/10 607/109  6,183,501 B1 2/2001 Latham 6,561,995 B1 5/2003 Thibodo 6,602,213 B1 8/2003 Figley 6,840,955 B2 1/2005 Ein 7,785,359 B2 8/2010 Latham	<b>OTHER PUBLICATIONS</b>  Written Opinion of the International Searching Authority for International Patent Application No. PCT/US2011/063021 dated Mar. 9, 2012, 5 pages. International Preliminary Report on Patentability for International Patent Application No. PCT/US2011/063021 dated Jun. 4, 2013, 6 pages.  * cited by examiner

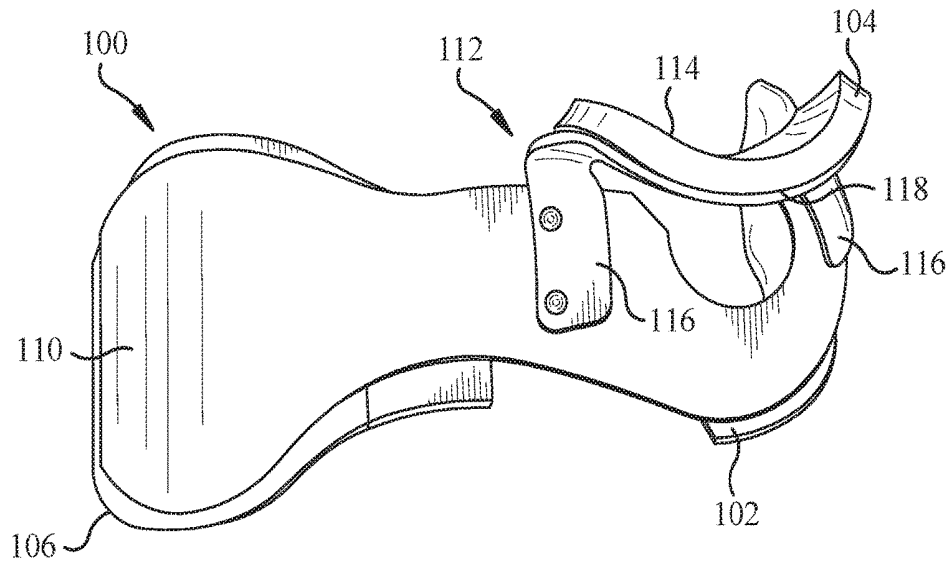

FIG. 1

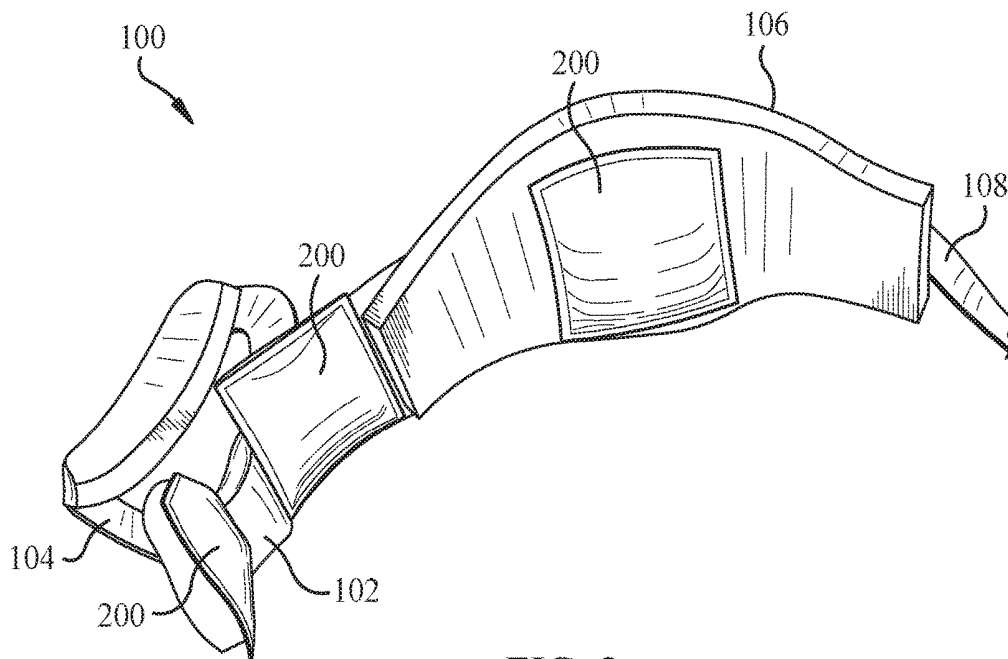

FIG. 2

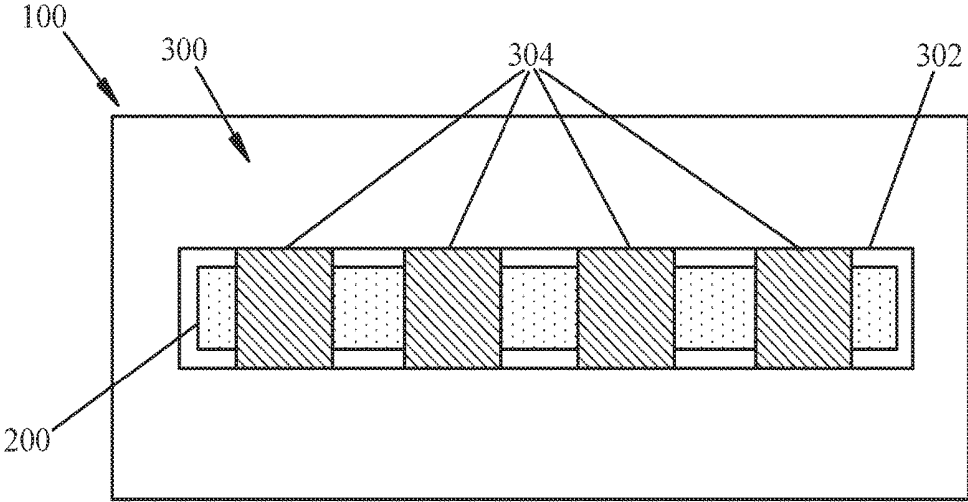

FIG. 3

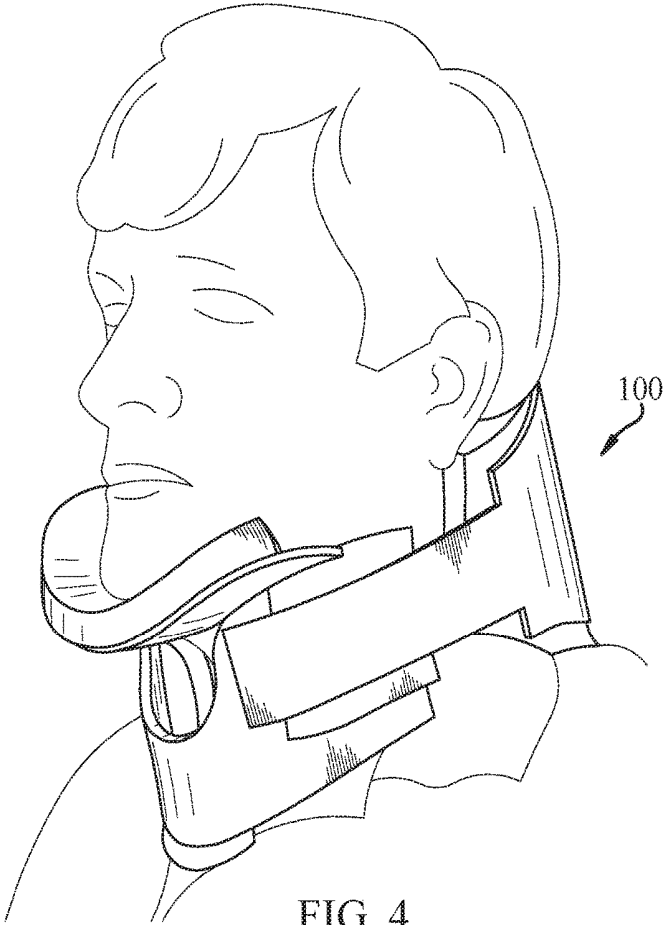

FIG. 4

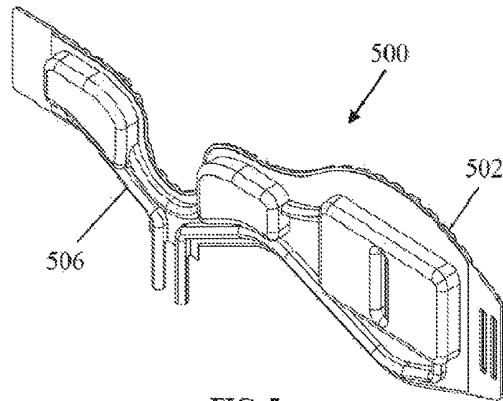

FIG. 5

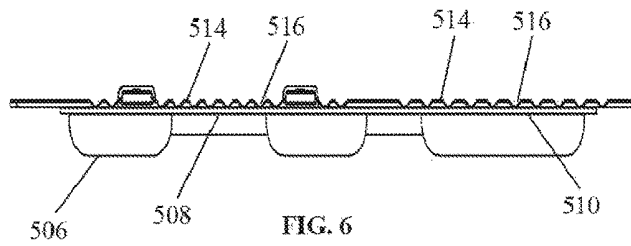

FIG. 6

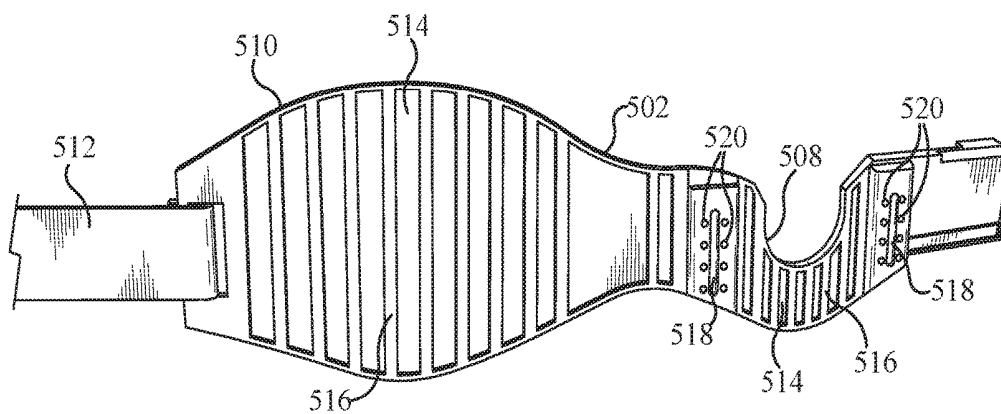

FIG. 7

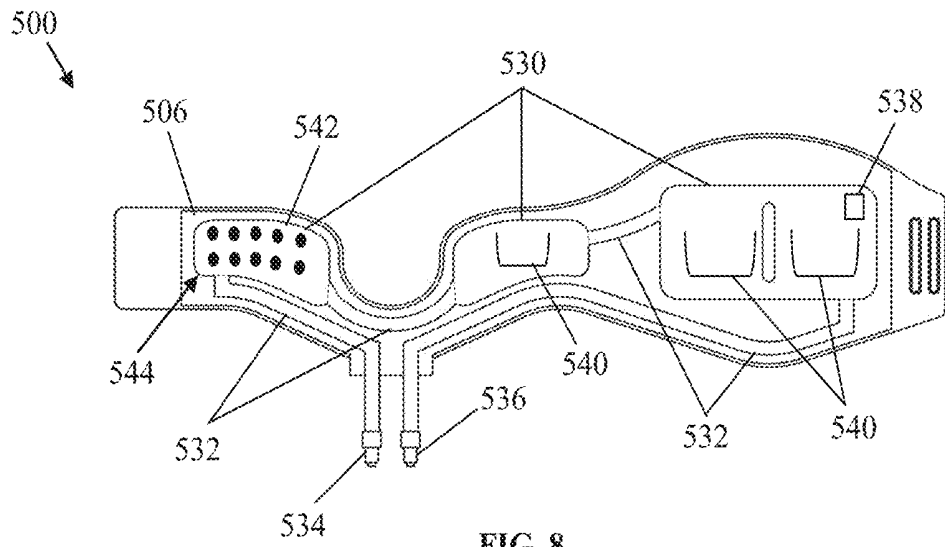

FIG. 8

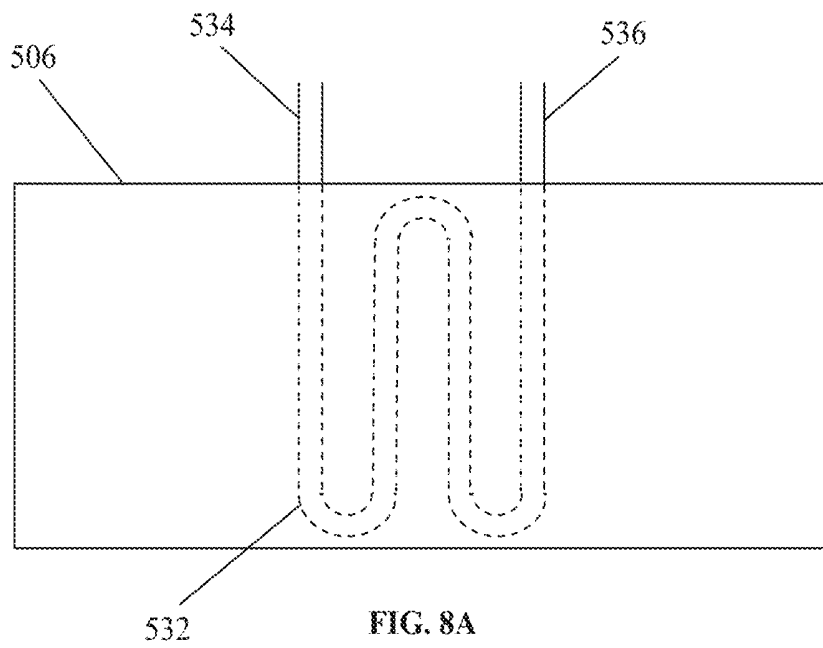

FIG. 8A

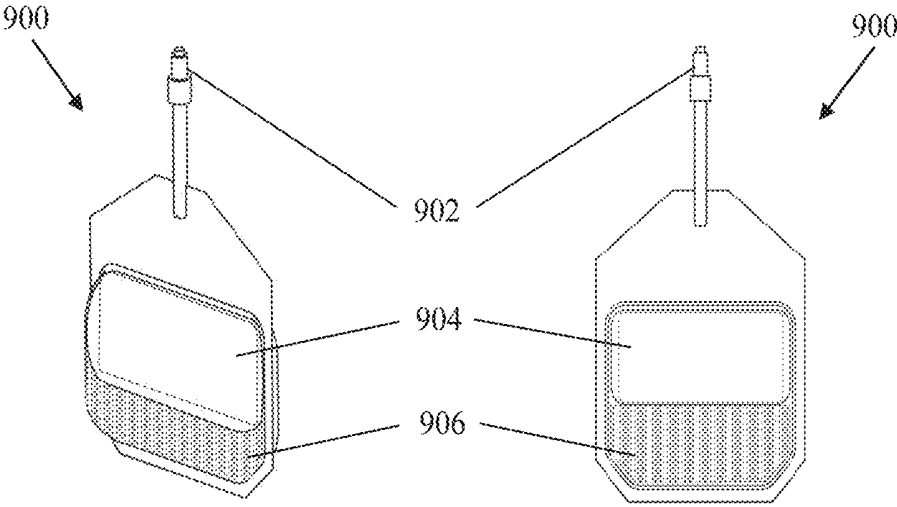

FIG. 9

FIG. 10

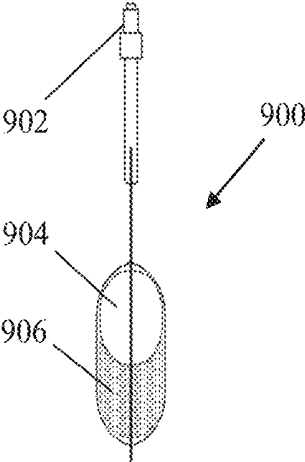

FIG. 11

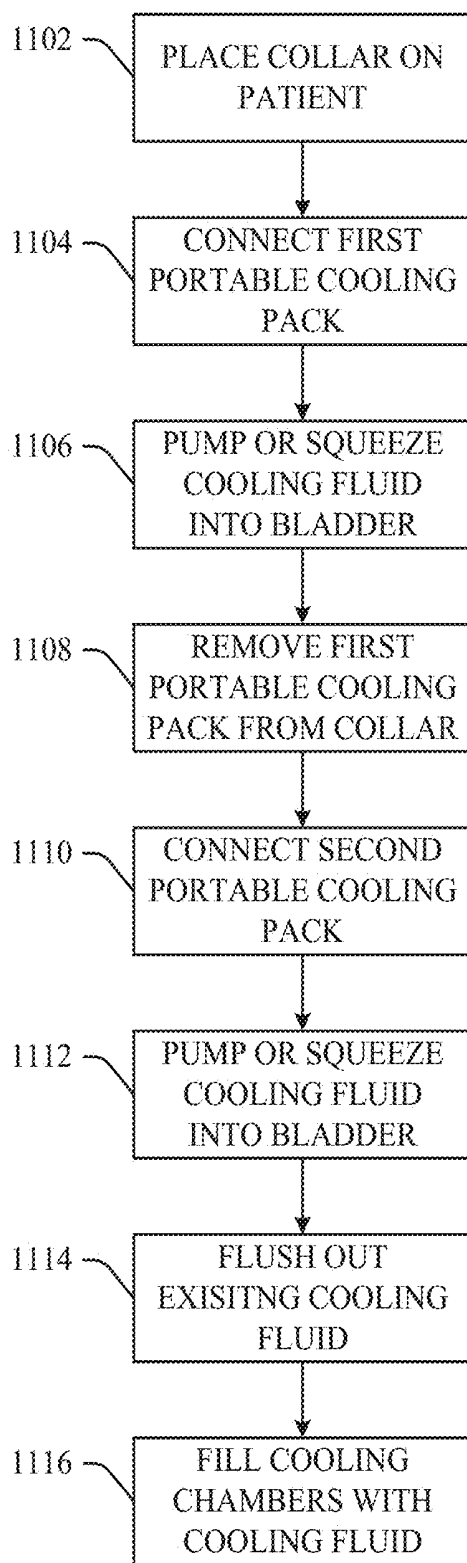

FIG. 11A

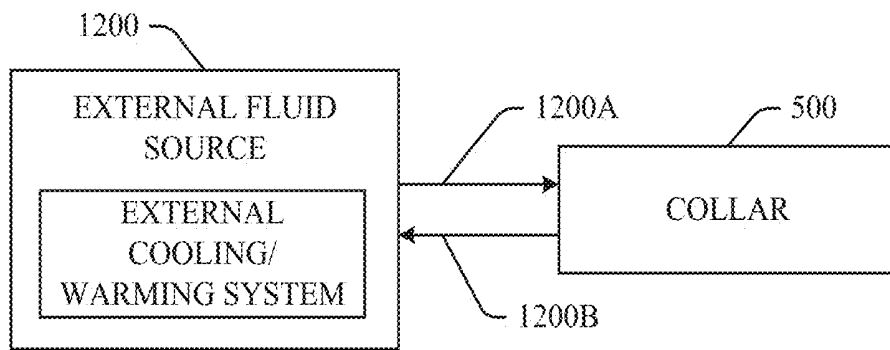

FIG. 12

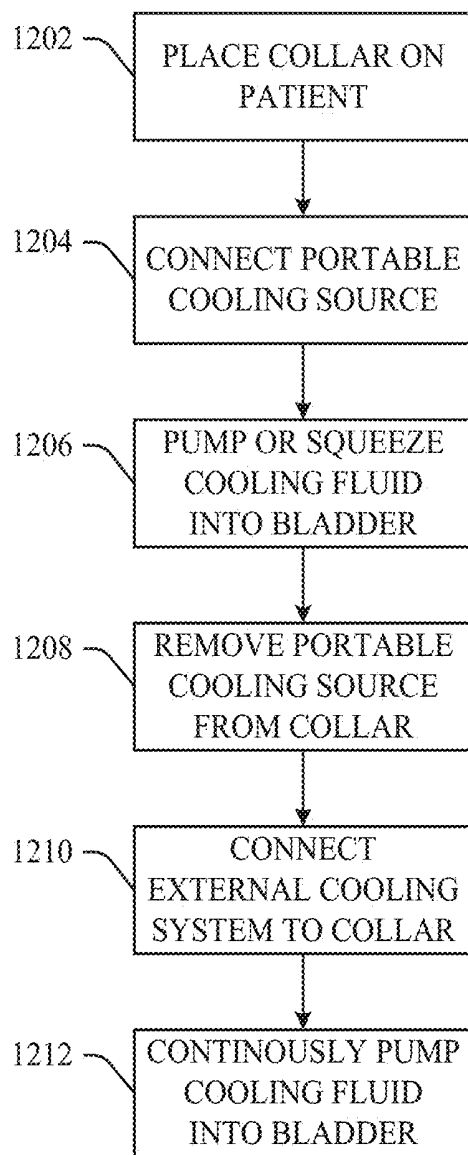

FIG. 12A

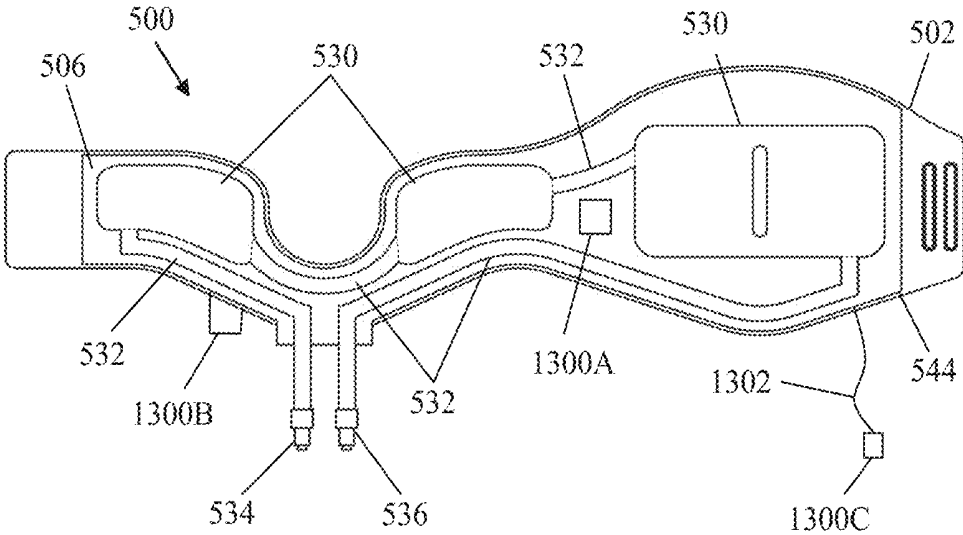

FIG. 13

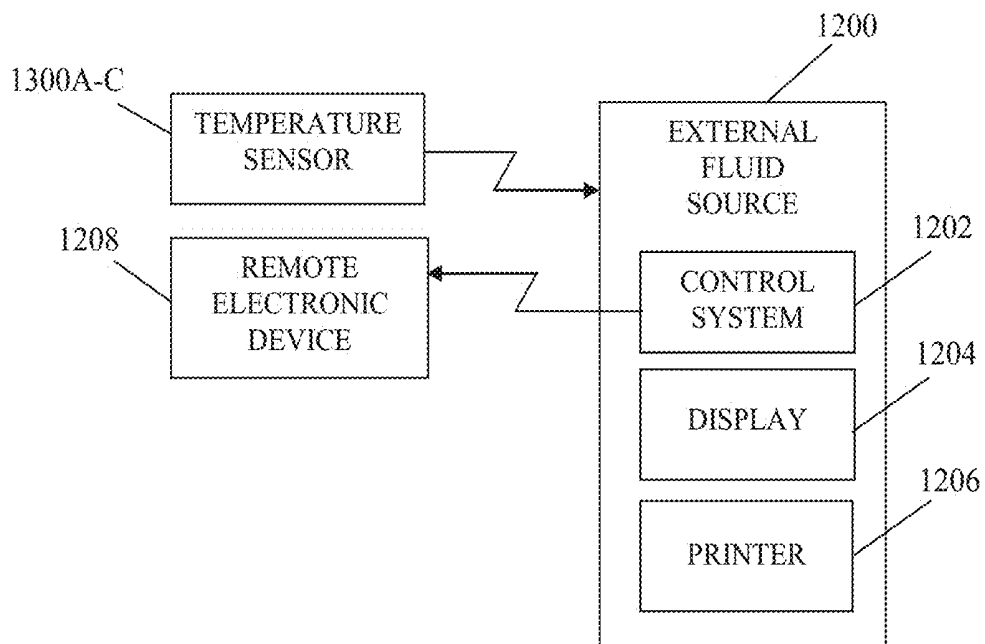

FIG. 14

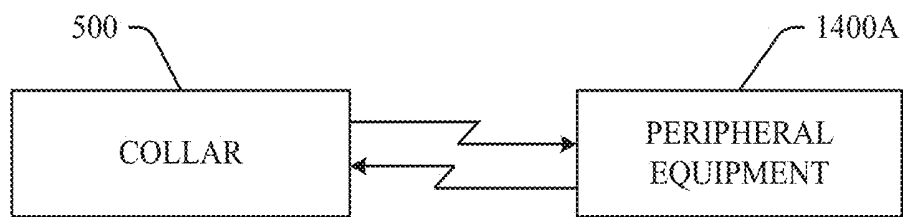

FIG. 14A

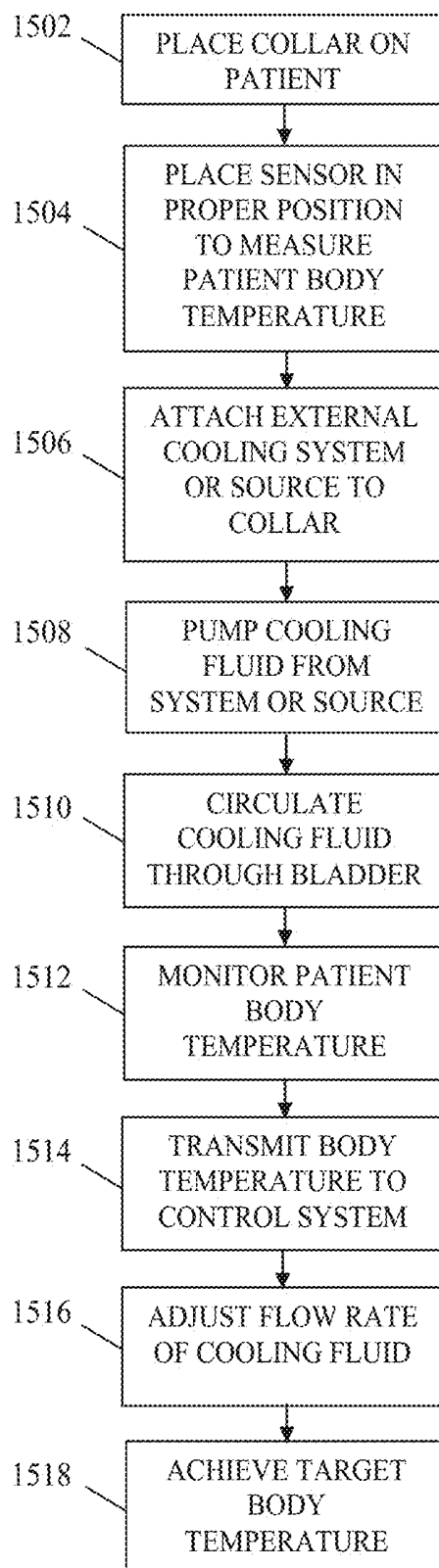

FIG. 15

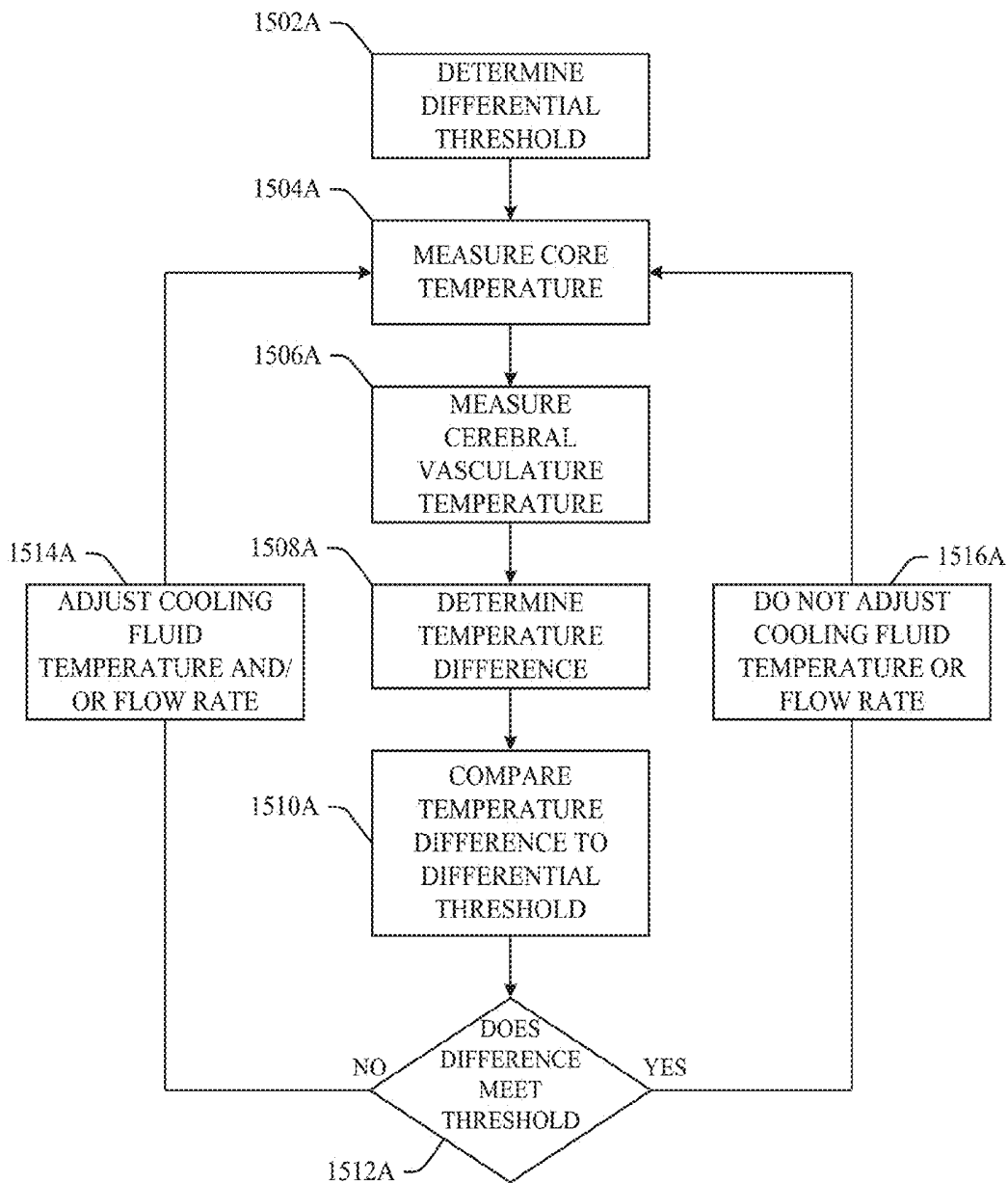

FIG. 15A

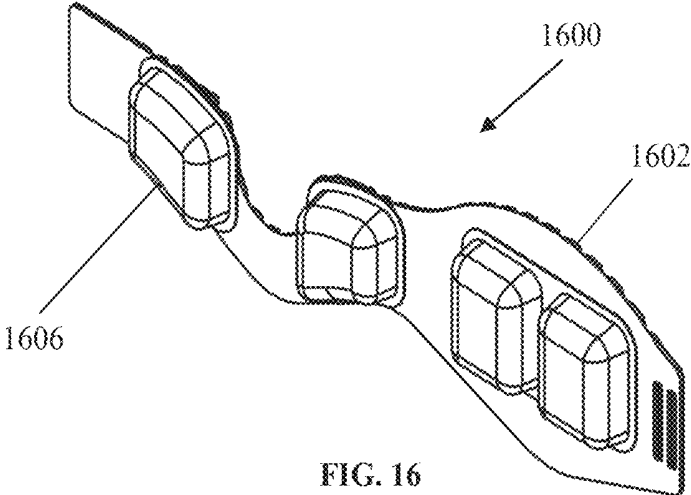

FIG. 16

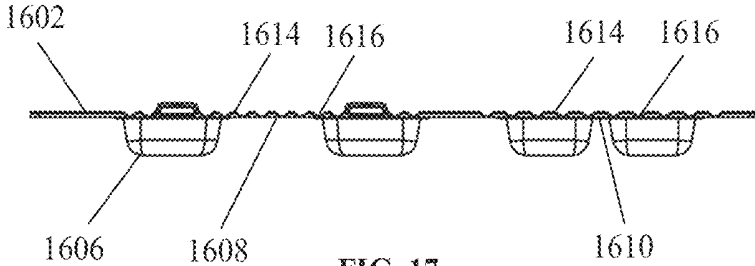

FIG. 17

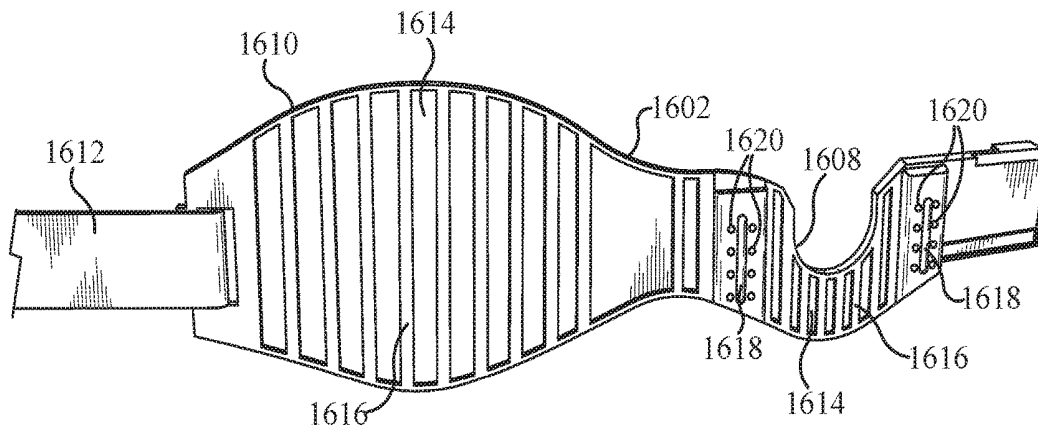

FIG. 18

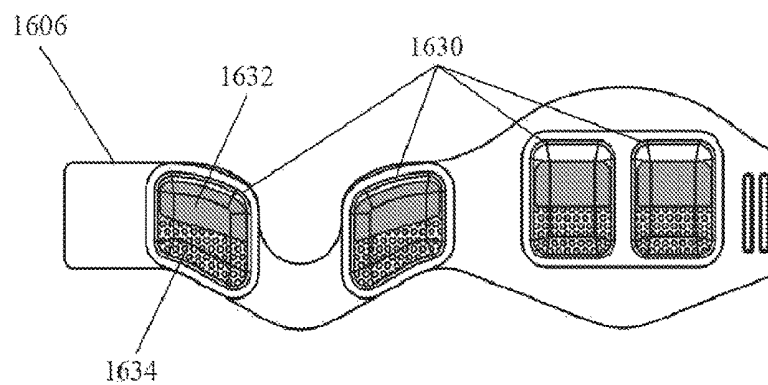

FIG. 19

# 1

## CERVICAL COLLAR

### CROSS-REFERENCE TO RELATED APPLICATIONS

This application is a Continuation-in-Part of pending U.S. patent application Ser. No. 14/052,346 entitled "CERVICAL COLLAR" filed Oct. 11, 2013, which is a Continuation-in-Part of pending U.S. patent application Ser. No. 13/309,173 entitled "CERVICAL COLLAR" filed Dec. 1, 2011, which claims the benefit of U.S. Provisional Patent Application Ser. No. 61/419,018 entitled "CERVICAL COLLAR" filed on Dec. 2, 2010. The entirety of the above-noted applications is incorporated herein by reference.

### ORIGIN

The innovation disclosed herein relates to a cervical collar and more particularly to a cervical collar employing a cooling device for therapeutic hypothermia.

### BACKGROUND

A "neck brace" or "cervical collar" is a medical, and more particularly an orthopedic, device that is often used to support the cervical portion of a patient's spinal cord by immobilizing the head and neck region. These devices are often used by emergency medical technicians (EMTs), for example when responding to victims of traumatic head or neck injuries. Other uses of the devices include treatment of chronic medical conditions, sports injuries or the like.

Traumatic head or neck injury can expose a patient to extensive spinal cord injury which could escalate to full or partial paralysis, or even death. In an effort to minimize these risks and to stabilize the top vertebrae, EMTs, and other medical personnel, often position a cervical collar on patients as a precautionary measure. Additional stabilization methods can be accomplished by way of other devices such as a backboard. Other uses of the cervical collar are for treatment of injuries including, strains, sprains or whiplash.

The innovation disclosed herein is an improvement to the conventional cervical collars described above.

### SUMMARY

The following presents a simplified summary of the innovation in order to provide a basic understanding of some aspects of the innovation. This summary is not an extensive overview of the innovation. It is not intended to identify key/critical elements of the innovation or to delineate the scope of the innovation. Its sole purpose is to present some concepts of the innovation in a simplified form as a prelude to the more detailed description that is presented later.

In accordance one aspect of the innovation, a system that facilitates therapeutic hypothermia that includes a cervical collar including an outer shell having a front portion and a back portion fixedly coupled to the front portion on one side and removably coupled to the front portion on an opposite side, and a bladder disposed on an interior of the outer shell, wherein the bladder selectively targets blood flowing through cerebral circulation arteries thereby changing a temperature of the blood flowing through the cerebral circulation arteries to a patient's brain.

In accordance with another aspect of the innovation, a cervical collar is disclosed that includes an outer shell having a front portion and a back portion fixedly coupled to the front portion on one side and removably coupled to the

# 2

front portion on an opposite side, a bladder configured to hold fluid disposed on an interior of the outer shell, and an indicator that changes color based on a change in a measurable event, wherein the bladder is the indicator.

In accordance with still another aspect of the innovation, a method of inducing therapeutic hypothermia is disclosed that includes placing a cervical collar on a patient's neck, circulating cooling fluid through the cervical collar, determining a differential threshold, measuring the patient's core temperature, measuring the patient's cerebral vasculature temperature, determining a difference between the patient's core temperature and the patient's cerebral vasculature temperature, comparing the difference to the differential threshold, and determining if the difference meets the differential threshold.

To the accomplishment of the foregoing and related ends, certain illustrative aspects of the innovation are described herein in connection with the following description and the annexed drawings. These aspects are indicative, however, of but a few of the various ways in which the principles of the innovation can be employed and the subject innovation is intended to include all such aspects and their equivalents. Other advantages and novel features of the innovation will become apparent from the following detailed description of the innovation when considered in conjunction with the drawings.

### BRIEF DESCRIPTION OF THE DRAWINGS

FIGS. 1 and 2 are exterior and interior views of a cervical collar incorporating a cooling device in accordance with aspects of the innovation.

FIG. 3 is a block type diagram of the cervical collar of FIGS. 1 and 2 incorporating an example embodiment of the cooling device in accordance with aspects of the innovation.

FIG. 4 is a perspective view showing the cervical collar of FIGS. 1 and 2 fitted to the patient in accordance with aspects of the innovation.

FIG. 5 is a perspective view of another embodiment of a cervical collar incorporating a cooling device in accordance with aspects of the innovation.

FIG. 6 is a top view of the cervical collar of FIG. 5 in accordance with aspects of the innovation.

FIG. 7 is a rear view of the cervical collar of FIG. 5 in accordance with aspects of the innovation.

FIG. 8 is a front view of the cervical collar of FIG. 5 in accordance with aspects of the innovation.

FIG. 8A is a block type diagram of another embodiment of a cervical collar incorporating a cooling device in accordance with aspects of the innovation.

FIGS. 9-11 are perspective, front and side views respectively of a fluid source in accordance with aspects of the innovation.

FIG. 11A illustrates a method of operating the cervical collar with portable fluid sources in accordance with aspects of the innovation.

FIG. 12 is a block diagram illustration of an external fluid system fluidly communicating with the cervical collar in accordance with an aspect of the innovation.

FIG. 12A illustrates a method of transitioning from a portable fluid source to an external fluid system in accordance with aspects of the innovation.

FIG. 13 is a front view of the cervical collar of FIG. 5 incorporating a temperature sensing device in accordance with an aspect of the innovation.

FIG. 14 is a block diagram illustration of the external cooling system communicating with peripheral electronic devices in accordance with an aspect of the innovation.

FIG. 14A is a block diagram illustration of the cervical collar communicating with peripheral electronic devices in accordance with an aspect of the innovation.

FIG. 15 illustrates a method of operating the cervical collar of FIG. 13 in accordance with aspects of the innovation.

FIG. 15A illustrates a method of adjusting cooling fluid in the cervical collar in accordance with an aspect of the innovation.

FIG. 16 is a perspective view of another embodiment of a cervical collar incorporating a cooling device in accordance with aspects of the innovation.

FIG. 17 is a top view of the cervical collar of FIG. 16 in accordance with aspects of the innovation.

FIG. 18 is a rear view of the cervical collar of FIG. 16 in accordance with aspects of the innovation.

FIG. 19 is a front view of the cervical collar of FIG. 16 in accordance with aspects of the innovation.

#### DETAILED DESCRIPTION

The innovation is now described with reference to the drawings, wherein like reference numerals are used to refer to like elements throughout. In the following description, for purposes of explanation, numerous specific details are set forth in order to provide a thorough understanding of the subject innovation. It may be evident, however, that the innovation can be practiced without these specific details.

While, for purposes of simplicity of explanation, the one or more methodologies shown herein, e.g., in the form of a flow chart, are shown and described as a series of acts, it is to be understood and appreciated that the subject innovation is not limited by the order of acts, as some acts may, in accordance with the innovation, occur in a different order and/or concurrently with other acts from that shown and described herein. Moreover, not all illustrated acts may be required to implement a methodology in accordance with the innovation.

Following is a discussion of the innovation and some example applications of the features, functions and benefits of employing a stabilizing device having a cooling (or warming device for certain medical applications) device as described herein. The innovation, in a broad application, is directed to the concept of induced or therapeutic hypothermia. Therapeutic hypothermia is a medical treatment for lowering one's core temperature to, for example, around 33° Celsius or other target temperature. Therapeutic hypothermia can be used to reduce the risk of tissue injury due to a period of insufficient blood flow caused by, for example, cardiac arrest or the occlusion of an artery by an embolism, as often occurs in the case of strokes. Studies have demonstrated, as is appreciated by those knowledgeable in the art that patients at risk for ischemic brain injuries have better results if treated with therapeutic hypothermia within the first sixty minutes, known as the "golden hour" by medical personnel, after the traumatic event.

Therapeutic hypothermia may be induced by either invasive or non-invasive procedures. Some non-invasive procedures may include packing or placing cold packs, cold compresses in the axil area, under the armpits or in the groin area to try to cool blood vessels. Another non-invasive procedure includes placing a chilled water blanket or torso vest and/or leg wraps in direct contact with the patient's skin. Some invasive procedures may include administering

approximately 2,000 ccs (two bags) of a normal chilled saline solution, often referred to as a crystalloid, or placing a catheter in the inferior vena cava via the femoral vein.

The innovation disclosed herein enables pre-hospital care providers to get a thorough jumpstart of inducing therapeutic hypothermia through a non-invasive procedure. As used herein, pre-hospital care providers can include care administered by EMTs, paramedics, army medics, sports trainers, etc. In other words, the innovation can be employed by most anyone in the field. Similarly, the features, functions and benefits can be employed in a hospital or other medical care facility without departing from the spirit and/or scope of the innovation described herein. Thus, the innovation disclosed herein can be used by any type of medical personnel including those in the field or in a facility by a medical professional or caregiver.

While the innovation and the example embodiments described herein are directed to a cervical collar that includes a cooling device to target the carotid artery, it is to be appreciated that the features, functions and benefits of the innovation can be applied to other regions of the body for cooling or warming. Essentially, most any region whereby blood flows and can be affected by the cooling device of the stabilizing device. For instance, areas where pulse points are located are most often good candidate regions for placement of the innovation. For example, in addition to the spinal/neck region, the innovation can be employed in the axil area, groin area, legs, arms, torso, etc. As will be understood, in order to enhance effects of cooling, it is important to cool as much blood as possible, thus, highly vascular regions are key regions for implementation, e.g., jugular veins, carotid arteries. In addition, it is to be understood that the innovation disclosed herein can also be used as a warming device. Thus, the innovation can be connected to a fluid source that can be used to circulate warming fluid through the innovation as described herein. Therefore, the example cervical collar disclosed herein is for illustrative purposes only and is not intended to limit the scope of the innovation.

In accordance with some aspects of the innovation, the innovation facilitates the placement of the cooling device in strategic anatomical positions on the neck region. Thus, the cooling device of the cervical collar can target the carotid arteries, which supplies the supply of blood flow to the brain, in the interior portion of the neck. In other aspects, the cooling device can target the posterior portion of the neck to cool the cervical areas of the neck to decrease swelling around the posterior portion of the neck including the spinal cord area and essentially cooling the neck as a whole. Thus, the cervical collar is capable of decreasing the temperature of the blood in highly vascular regions so as to enhance induced hypothermic reaction. More specifically, the cervical collar can selectively cool the cerebral vasculature relative to the whole body thereby inducing hypothermia. Because the cooling effect to the patient is targeted to a specific area (e.g., the brain), any side effects associated with whole body cooling are significantly reduced. Effectively, the cervical collar can most often be employed in three primary scenarios, stroke, heart attack, and head/neck injury or trauma.

Referring now to the figures, FIGS. 1 and 2 illustrate an example embodiment of a stabilizing device, such as a cervical collar 100 that includes a cooling device in accordance with aspects of the innovation. The cervical collar 100 is most often used to immobilize one's neck in a trauma situation. The cervical collar 100 includes a front portion 102, an optional support 104 for supporting a patient's chin attached to the front portion 102, a back portion 106, and a

fastening device **108** such as a strap. The fastening device **108** is attached to one side of the back portion **106** and extends toward the front portion **102**. When the patient is wearing the cervical collar **100**, the fastening device **108** removably attaches one side of the front portion **102** to thereby couple the front portion **102** to the back portion **106**. The fastening device **108** may be any type of device, such as but not limited to a strap that employs a Velcro™-type fastener, snaps, buttons, hooks, etc. It is to be appreciated that most any means for attachment and/or adjustment can be employed in accordance with other aspects of the innovation. It is to be further appreciated that the fastening device **108** is adjustable to allow the cervical collar **100** to conform to patients having different sized necks.

The front and back portion **102**, **106** are both made from a soft foam material that can be bent to conform to with the patient's neck, back, and shoulders. It is to be appreciated, however, that the front and back portion **102**, **106** can be made from any suitable material as long as it conforms to the patient's neck, such as but not limited to, natural and synthetic polymers, carbon-reinforced materials, metal wire reinforced materials, etc.

Referring specifically to FIG. 1, a flexible integrated outer shell **110** is attached to both the back portion **106** and the front portion **102** thereby coupling the other side of the front portion **102** to the other side of the back portion **106**. The outer shell **110** can be attached to the front and back portion **102**, **106** via any suitable means, such as but not limited to, an adhesive, rivets, etc. The outer shell **110** is flexible in a horizontal direction thus, allowing the cervical collar **100** to attach around the patient's neck. The outer shell **110**, however, is more rigid in the vertical direction thus, giving the cervical collar its stabilization characteristics. The outer shell **110** can be any suitable rigid material, such as but not limited to a molded plastic (e.g., polyethylene, polystyrene, etc.).

Still referring to FIG. 1, the support **104** for supporting the patient's chin, also referred to as a chin cup, is attached to the front portion **102**. It is to be appreciated that the support **104** is an optional device and the cervical collar **100** can still perform its intended function in accordance with aspects of the innovation without employing the support **104**. The support **104** is disposed beneath the patient's chin for cervical support. The support **104** includes an attachment piece **112** that attaches to the front portion **102** and a rest piece **114**. The attachment piece **112** includes two leg members **116** and a curved portion **118** connecting the two leg members **116**. The leg members **116** are attached, via rivets or any other suitable means, to the front portion **102** to secure the support **104** to the cervical collar **100**. The rest piece **114** is attached, via an adhesive or any other suitable means, to the curved portion **118** to support the patient's chin.

The support **104** can be fixedly attached or adjustably attached to the cervical collar **100**. It is understood that individuals have different size necks and chins. Thus, in accordance with aspects of the innovation, the support **104** can be height (or otherwise) adjustable or interchangeable to facilitate comfort and enhanced immobilization effect. For example, in accordance with aspects of the innovation, the support **104** can be adjusted using a tongue and groove mechanism, where the support **104** can act like a tongue and the cervical collar **100** can employ the associated grooves. In accordance with other aspects of the innovation, the support **104** can include preselected heights. For example, a spring-button can be used that catches within a hole in the cervical collar **100** to secure the support **104** at a pre-selected height

position. It is to be appreciated that other aspects can employ grooves, hardware (e.g., wing-nuts), etc. for adjustment without departing from the scope of the innovation. Thus, the adjustability of the support **104** and the cervical collar **100**, via the fastening device **108**, provides a universal fit and applicability of the innovation. Therefore, the cervical collar **100** is adjustable for both length (e.g., support **104**) as well as width (e.g., fastening device **108**).

In the examples illustrated below, the cervical collar **100** further includes a cooling device that may be in the form of a cooling pack (e.g., chemical pack) integrated into the cervical collar **100**, a retainer to receive and hold a cooling pack (e.g., chemical pack, ice pack, sterile water cooling pack, etc.), or a bladder having chambers to allow cooling fluid to be pumped through essential portions of the cervical collar **100**.

FIG. 2 illustrates one example embodiment of the cooling device in accordance with aspects of the innovation. The cooling device in this embodiment is a cooling pack **200** that can be either integrated into the cervical collar **100** or can be inserted into a retaining device described below. The cooling pack **200** can be strategically disposed at essential locations on the cervical collar **100** to target the areas of the neck described above. For example, one or more cooling packs **200** can be located on the front portion **102** to target the carotid arteries. In addition, one or more cooling packs **200** can be located on the back portion **106** to target the spinal cord area. The cooling pack **200** can be any type of cooling pack, such as but not limited to chemical pack (e.g., granule-activation packets that when activated releases a cooling agent to provide the desired cooling effect). For example, the granule-activation packets use ammonium nitrate and water. When a user strikes the cooling pack **200** with the palm of a hand, a prescribed amount of water will mix with the ammonium nitrate thereby creating a cold compress. Once the cooling packs **200** are activated, the cervical collar **100** can be placed on the patient to provide the desired therapeutic hypothermia to essential portions of the neck area described above.

The retaining device receives and holds a cooling pack, such as but not limited to, an ice pack or a chemical pack as described above. The retaining device can be strategically disposed at essential locations on the cervical collar **100** to target the areas of the neck described above. For example, one or more retaining devices can be located on an interior side of the front portion **102** to target the carotid arteries. In addition, one or more retainers can be located on an interior side of the back portion **106** to target the spinal cord area. The retaining device can be in the form of a pocket, a pouch, straps, etc. and can be made from any suitable material, such as but not limited to, plastic, a mesh like material, etc. that sufficiently conducts the cooling effects of the cooling pack. It is to be appreciated that the options for the type and material of the retaining device are limitless and as such all of which are included in the scope of the innovation.

For example, FIG. 3 is a block diagram illustration of the cervical collar **100** described above incorporating an example retaining device **300** in accordance with aspects of the innovation. The retaining device **300** includes a channel **302** and one or more covers **304** to hold the cooling pack **200** described above in place. The cover **304** may be made from any material that sufficiently conducts the cooling effects of the cooling pack **200** and that does not irritate the patient's skin. Further, the cover **304** can be a single piece or multiple pieces. In this embodiment, the cervical collar **100** can be packaged and transported in a flat condition to save space in transport vehicles such as emergency medical vehicles.

When emergency personnel require the use of the cervical collar **100**, the cooling pack **200** can be inserted or slid into the channel **302** and placed on the patient. When the cervical collar **100** is placed on the patient, the cooling pack **200** will activate thereby providing the required cooling effect. It is to be appreciated that the cooling pack **200** can be integrated into the channel **302** thus, saving the emergency personnel the time of placing the cooling pack into the channel **302**. Once the cooling packs are secured by the one or more retaining devices, the cervical collar **100** can be placed on the patient to provide the desired therapeutic hypothermia to essential portions of the neck area described above.

For example, FIG. **4** illustrates a perspective view of the cervical collar **100** described above fitted on a patient. As illustrated, the cervical collar **100** has the ability to provide therapeutic hypothermia upon vascular regions to facilitate promptly treating a patient and to minimize risk of further injury than that of conventional cervical collars.

FIGS. **5-8** represent another example embodiment of a cervical collar **500** (hereinafter "collar") incorporating a cooling device. In this embodiment, the cooling device allows cooling (or warming) fluid from an external fluid source, such as but not limited to, a portable fluid source or an external continuous fluid system to be squeezed or pumped into and/or circulated through essential portions of the collar **500**. The collar **500** includes an outer shell **502**, an adjustable support (not shown), and a bladder **506**. It is to be appreciated that while the collar **500** can be used for inducing hypothermia, the collar **500** can also be used as a standard cervical collar when a patient does not require therapeutic hypothermia.

Referring to FIGS. **6** and **7**, the outer shell **502** includes a front portion **508** fixedly coupled to a back portion **510** on one side and a fastening device **512** attached to the back portion **510** and removably coupling the front and back portions **508**, **510** on an opposite side. The features of the fastening device **512** are similar to the fastening device **108** described above and, as such, will not be repeated.

The outer shell **502** is made from a flexible plastic material, such as but not limited to polyethylene, polystyrene, etc. Further, both the front and back portions **508**, **510** include multiple panels **514** each connected by hinged portions **516** that further facilitate in the flexibility of the outer shell **502**. This configuration allows EMT personnel to control the flexibility of the collar **500** and easily adjust the collar **500** to fit the patient. In addition, the flexibility characteristic allows the collar **500** to be packaged in a flat state thereby optimizing volume space for shipping and/or storage purposes. The front portion **508** of the outer shell **502** further includes multiple slots **518** and multiple recesses **520** disposed on each side of each slot **518**. The multiple slots **518** and multiple recesses **520** facilitate attachment and adjustment of the support to the collar **500** subsequently described.

The support is used to support the patient's chin and is adjustable to conform to the patient similar to the support **104** described above. The support includes attachment legs that attach the support to the front portion **508** and a connection part connecting distal ends of the attachment legs. The connection part serves to support the patient's chin. Multiple slots **518** are defined in the front portion **508** to receive the attachment legs to thereby connect the support to the collar **500**. The support can be adjusted by sliding each attachment leg in each slot **518** to a desired position. The attachment legs engage recesses **520** defined on each side of each slot **518** to lock the support in its desired position.

As mentioned above, the connection part provides a connection between the distal ends of the attachment legs. The connection point between the attachment legs and the connection part is hinged to facilitate packaging. Specifically, when the collar **500** is packaged in a flat state, mentioned above, one attachment leg is disconnected from the collar **500** and laid in a flat state. This is possible because of the hinged connection.

Referring to FIG. **8**, the bladder **506** is a single piece bladder type device that includes multiple cooling chambers (or reservoirs) **530**, multiple passageways **532**, an inlet port **534**, and an outlet port **536**. The passageways **532** provide a fluid connection between the chambers **530** and the inlet port **534**, between the chambers **530** and the outlet port **536**, and between the chambers **530** themselves.

The bladder **506** attaches to an interior portion of the outer shell **502** and can be made from multiple sheets of a flexible material that is conducive to conducting the cooling effects of the cooling, such as but not limited to, polyethylene. The multiple sheets can be arranged in numerous configurations, such as but not limited to, two sheets, three sheets, four sheets, etc. In instances where there are more than two sheets, multiple layers may be arranged on the patient side of the bladder **506** to facilitate the prevention of frost bite. The bladder **506** may be attached to the interior portion of the outer shell **502** by any suitable means, such as but not limited an adhesive.

The chambers **530** are an integral part of the bladder **506**. Specifically, to form the chambers **530**, the two flexible sheets are placed in a heat mold and hermetically sealed in an area surrounding the desired location of each chamber **530**. Although, the number of cooling chambers **530** illustrated in FIG. **8** is three, it is to be understood that the innovation is not dependent on the number of chambers **530** formed in the bladder **506**. Thus, the example embodiment described herein and illustrated in the figures is for illustrative purposes only and is not intended to limit the scope of the innovation. It is to be appreciated, however, that the number and location of the chambers **530** targets essential areas of the patient's neck (e.g., carotid arteries, spinal area, etc.) to provide optimum cooling to the cerebral vasculature.

For example, the innovative cervical collar **500** may be configured to selectively cool or target cerebral circulation arteries, which are arteries that supply blood to the brain. More specifically, the cervical collar **500** may be configured to target arteries that supply blood to the anterior portion of the brain, known as anterior cerebral circulation. These arteries include the internal (intracranial) carotid arteries, external carotid arteries, anterior cerebellar arteries, anterior inferior cerebellar arteries, middle cerebral arteries, anterior spinal arteries, the anterior communicating arteries, and the ophthalmic arteries. The cervical collar **500** may also be configured to target arteries that supply blood to the posterior portion of the brain known as posterior cerebral circulation, including the occipital lobes, the cerebellum, and the brainstem. These arteries include vertebral veins and arteries including subclavian arteries, basilar arteries, posterior cerebral arteries, posterior cerebellar arteries, posterior inferior cerebellar arteries, posterior communicating arteries, pontine arteries, the superior cerebellar arteries, and the posterior spinal artery. In addition, the innovative cervical collar can also be configured to provide cooling to portions of the cranium, such as but not limited to the petrous bone.

As mentioned above, the passageways **532** provide a connection between the chambers **530**, and between the chambers **530** and the inlet and outlet ports **534**, **536**. The passageways **532** may be comprised of embedded tubes or

may be integrally formed in the bladder **506**. Specifically, multiple tubes can be positioned at proper locations in the bladder **506** during formation of the chambers **530** described above, thus, embedding the tubes in the bladder **506**. The passageways **532** may also be integrally formed in the bladder **506** by hermetically sealing an area surrounding each passageway **532** similar to the formation of the chambers **530** described above.

The inlet and outlet ports **534**, **536** provide a connection between the bladder **506** and the external fluid system or source. The connection between the bladder **506** and the external fluid system or source can be any suitable mechanical connection device, such as but not limited to, quick couplers, a screw type device, etc. Further, the inlet and outlet ports **534**, **536** may include a valve to regulate the flow of cooling fluid into and/or out of the bladder **506**. It is to be appreciated that the inlet port **534** and the outlet port **536** can be switched. In other words, the inlet port **534** can serve as the outlet port **536** and the outlet port **536** can serve as the inlet port **534**.

Alternatively, still referring to FIG. **8**, pockets or sleeves **540** may be attached to one or more chambers **530** that accept cooling packs **200** described above. The cooling packs **200** may be used in the event that the external fluid system of source is not available.

In still yet another embodiment shown in FIG. **8**, one or more of the chambers **530** may include internal fasteners that connect a front **542** of the chamber to the back to thereby create a dimpled pattern **544**. The dimpled pattern **544** flattens out the front surface **540** of the chamber **530** to allow more surface area to contact the patient. In addition, the internal fasteners cause the fluid inside the chambers **530** to flow in more a random pattern.

In an alternative embodiment shown in FIG. **8A**, the bladder **506** can be modified to exclude the chambers and simply include passageways **532** that run through the bladder **506** in desired locations. The passageways **532** would connect to both the inlet and outlet ports **534**, **536** to allow the continuous circulation of cooling fluid, as described above.

One such example of a fluid source is a portable cooling pack **900** illustrated in FIGS. **9-11**. The portable cooling pack **900** includes a port **902** that acts as both an inlet port and an outlet port. The portable cooling pack **900** is a granule-activation packet that uses a fluid **904**, such as but not limited to, water and a chemical **906**, such as but not limited to, ammonium nitrate that when mixed together create a cooling fluid. When a user strikes the portable cooling pack **900** with the palm of their hand, a prescribed amount of water will mix with the ammonium nitrate thereby creating a cooling fluid. The cooling fluid from the portable cooling pack **900** can then be mechanically pumped or hand squeezed into the bladder **506** via the inlet port **534** and into each chamber **530** via the passageways **532**, as described below.

In addition, once the cooling fluid inside the bladder **506** begins to warm, the empty cooling pack **900** can be attached to the outlet port **536** and a new portable cooling pack **900** can be attached to the inlet port **534**. The cooling fluid from the new portable cooling pack **900** can then be pumped or squeezed into the bladder **506** thereby forcing or flushing the warm fluid out of the bladder **506** through the outlet port **536** and back into the original cooling pack **900**. Thus, cooling fluid can essentially be continuously pumped through the collar **506** by EMT personnel who do not have access to a continuous external cooling system (described below) in the field. In addition, the fluid may be manually squeezed (or

pumped) out of the bladder **506** such that the cervical collar **500** can function as a collar without the need to pump fluid through the bladder **506**.

For example, referring to FIG. **11A**, at **1102**, the cervical collar **500** is placed on the patient. At **1104**, the port **902** of a first cooling pack is connected to the inlet port **534** of the cervical collar **500**. At **1106**, cooling fluid from the first cooling pack is squeezed into the bladder **506** of the cervical collar **500** thereby filling the cooling chambers **530**. At **1108**, once the cooling fluid from the first cooling pack reaches an undesirable temperature, the first cooling pack, which is empty, is attached to the outlet port **536** (or alternatively can be or stay connected to the inlet port **534**). At **1110**, a second cooling pack is attached to the port not in use (e.g., inlet port or outlet port) on the cervical collar **500**. At **1112**, cooling fluid from the second cooling pack is squeezed into the bladder **506**. At **1114**, the existing cooling fluid in the cooling chambers **530** from the first cooling pack is flushed out of the cooling chambers **530** and back into the first cooling pack. At **1116**, cooling fluid from the second cooling pack fills the cooling chambers **530** with cooling fluid of a desired temperature.

In conjunction with the cooling packs **200**, **900** previously described, the cervical collar **500** may include an indicator **538** (see FIG. **8**) disposed on the retaining device **300** or on the bladder **506** (e.g., on at least one chamber **530** and/or at least one passageway **532**) that indicates an approximate body (core) temperature of the patient and/or an approximate temperature of the patient's cerebral vasculature and/or an approximate temperature of the cooling fluid in the fluid source **200**, **900**. In one embodiment, the indicator **538** may be an integrated portion of the cervical collar **500**. In another embodiment, the indicator **538** may be a separate temperature sensitive device (e.g., sticker, etc.) that can be attached to the cervical collar **500** by the EMT personnel. The separate temperature sensitive device may be removable and re-attachable so that it can be moved to different locations on the cervical collar **500**.

In one example, the indicator **538** can sequentially change color based on a change of a measurable event, such as but not limited to a change in a temperature of the cooling fluid. For example, the indicator **538** may be a first color (e.g., blue, dark blue, etc.) when the temperature of the cooling fluid is at a temperature (first temperature) that provides adequate cooling to the patient. As the temperature of the cooling fluid begins to lose its cooling effect (e.g., the cooling fluid begins to warm) or approaches (or reaches) a second temperature, the indicator **538** may turn a second color (e.g., orange). The second temperature can be any temperature that is higher than the first temperature (e.g., "x" degrees warmer than the first temperature). As the temperature of cooling fluid continues to warm or approaches (or reaches) a third temperature the indicator **538** may turn a third color (e.g., red) indicating that the cooling fluid is no longer providing adequate cooling to the patient. The third temperature can be any temperature that is higher than the second temperature and obviously higher than the first temperature (e.g., "y" degrees warmer than the second temperature, "z" degrees higher than the first temperature). The indicator **538** can provide a quick visual means for the EMT personnel to determine if the cooling pack **200** should be replaced or if additional cooling fluid should be pumped into bladder **506** with another cooling pack **900**.

Similarly, when the warm cooling fluid is flushed out and replaced with cold cooling fluid, the color of the indicator can change back to the first color (e.g., blue, dark blue, etc.). In addition, if the cooling fluid is gradually cooled from a

warm temperature, the color of the indicator can change back in sequence toward the first color. As the cooling fluid once again begins to warm, the above process can start over again.

In another example embodiment, the indicator **538** can change color based on a change of a measurable event, such as but not limited to, a passage of time where specific colors may represent an incremental passage of time. For example, the indicator **538** may be a first color (e.g., blue, dark blue, etc.) when the cooling fluid is first introduced. As time passes (e.g., 1, minute, 2 minutes, 3 minutes, etc.) the indicator **538** may change color to a second color (e.g., orange) to alert the EMT personnel how much time has passed. As more time passes, the indicator may turn a third color, fourth color, fifth color, etc.

In one example embodiment, the color change may be gradual, which may represent a passage of time in small increments (e.g., 1 minute increments, 2 minute increments, etc.). In another example embodiment, the color change may be more defined or abrupt (i.e., changing quickly from one color to another), which may represent a passage of time in larger increments (e.g., 5 minutes, 10 minutes, etc.). For example in one embodiment, orange may represent the passage of 5 minutes, red may represent the passage of 10 minutes, etc. In another example embodiment, every time the indicator changes color may represent an incremental passage of time (e.g., any color change represents a 5 minute increment, a 10 minute increment, etc.).

In this example embodiment, the indicator **538** can provide a quick visual means for the EMT personnel to determine how much time has passed. Since time is very crucial in traumatic head and neck injuries, the quick reference indicator provides the EMT personal a means to quickly determine how much time has passed.

In another example embodiment, the bladder **506** or any portion thereof, such as one or more cooling chambers **530** or one or more passageways **532**, may act as the indicator. For example, the bladder **506** may be made from a material that changes color based on temperature, as previously described.

In another example embodiment, the outer shell **502** may be made from a transparent material or may include a viewing window that permits the EMT personnel to view the patient's neck for signs of trauma and/or view the indicator **538** described above. In still another embodiment, the bladder **506** may be made from a transparent material that allows the EMT personnel to see the cooling fluid. As such, the cooling fluid itself may act as the temperature indicator. For example, a color of the cooling fluid may change color as the temperature of the cooling fluid changes, as described above.

Referring to FIG. 12, as mentioned above, another fluid source **1200** that the collar **500** can be connected to is an external cooling system **1200** that can continuously pump cooling fluid **1200A** at a desired temperature through the bladder **506** thereby and flush out the warm cooling fluid **1200B**, thereby providing a continuous circulation of cooling fluid at the desired temperature. Thus, the temperature of the cooling fluid can be regulated to maintain a predetermined temperature or adjust the temperature as desired. As such, this embodiment can be used to perform therapeutic hypothermia over an extended period of time to treat a particular type of injury or perform a particular type of procedure. For example, this example embodiment, as well as those described above, can be in the form of a wrap that employs the bladder **506** to treat injuries to the arms,

shoulder, legs, knees, etc., as well as the neck area, where therapeutic hypothermia is required over an extended period of time.

Still referring to FIG. 12, it is to be understood that the innovative cervical collar disclosed herein can also be used as a warming device in appropriate medical applications. Thus, the cervical collar can be connected to the external fluid source **1200** that can pump warming fluid through the cervical collar as described herein.

Still referring to FIG. 12, the innovative cervical collar **500** can also be used as a compress. For example, in post-operative care, a practitioner can simply set the temperature of the fluid that does not induce hypothermia for the purpose of applying a cool or warm compress to the designated area. Still further, the practitioner can regulate the temperature of the fluid to transition between a cold compress and a warm compress and vice versa for therapeutic reasons.

In addition, referring to FIG. 12A, the external cooling system **1200** in conjunction with the cooling packs **900** can provide a smooth transition from providing portable cooling fluid in the field to a continuous cooling system in a medical facility. Thus, once the patient arrives at a medical facility the cooling source can be transitioned from the portable cooling pack **900** described above to the external cooling system **1200** as illustrated in FIG. 12A. Specifically, at **1202**, the cervical collar is placed on the patient. At **1204**, the portable cooling pack **900** is connected to the inlet port **534**. At **1206**, cooling fluid from the cooling pack **900** is pumped or hand squeezed into the bladder **506** thereby filling the cooling chambers **530**. At **1208**, once the patient arrives at a facility (e.g., medical facility) that has an external cooling system **1200**, the portable cooling pack **900** is removed from the inlet port **534**. At **1210**, the external cooling system **1200** is connected to the cervical collar **500**. At **1212**, cooling fluid is pumped into the bladder **506**, which flushes out the existing cooling fluid inside the cooling chambers **532**.

It is to be understood that the transition process illustrated in FIG. 12A can also be from the continuous cooling system to the portable cooling packs. For example, if a trauma patient is connected to the continuous cooling system in a medical facility that is not capable of handling trauma patients, the patient can be transitioned from the permanent system to the portable cooling packs in order to transport the patient to a trauma facility.

Referring to FIG. 13, the example embodiment of the cervical collar **500** illustrated in FIG. 5 above may include one or more temperature sensors **1300A** or **1300B** or **1300C** that may measure a body (or core) temperature of the patient and/or a cerebral vasculature temperature of the patient. Although like features are referenced in FIG. 13, a description of such features will not be repeated for simplicity. The temperature sensors **1300A-C** illustrated in FIG. 13 can be any type of temperature sensor, such as but not limited to, an infrared sensor, a stick tab sensor, etc. The presence of a temperature sensor allows medical personal to not only monitor, but also regulate the patient's body and/or cerebral vasculature temperature via the external cooling system mentioned above. Thus, to increase or decrease either temperature of the patient, the flow rate of the external cooling system is either increased or decreased respectively (alternatively, the temperature of the cooling can be adjusted as opposed to the flow rate). Thus, medical personnel are able to maintain the patient's body or cerebral vasculature temperature at a target temperature to thereby minimize the traumatic effect to the patient. It is to be understood, that any type of sensor that measures a physical characteristic of the

patient may be included in the cervical collar. For example, in lieu of or in addition to a temperature sensor, a sensor may be included that measures the patient's pulse, etc.

In one example embodiment, the temperature sensor 1300A can be disposed on the bladder 506 such that when the cervical collar 500 is placed on the patient, the temperature sensor 1300A is already positioned to monitor the body temperature of the patient.

In another example embodiment, the temperature sensor 1300B can have a tab like configuration that attaches to a bottom edge 546 (as shown in FIG. 13) of the cervical collar 500. Thus, when the cervical collar 500 is placed on the patient, the temperature sensor 1300B is already positioned to monitor the body temperature of the patient. It is to be appreciated that the tab like temperature sensor 1300B can attach to a top or side edge of the cervical collar 500.

In still yet another example embodiment, the temperature sensor can be attached to any location (e.g., the outer shell 502, the bladder 506, etc.) on the cervical collar 500 via a tether 1302, as illustrated by temperature sensor 1300C. Once the cervical collar 500 is in place the temperature sensor 1300C can be placed on the patient at any convenient location, such as but not limited to, the forehead, neck area, etc.

Referring to FIG. 14, in another embodiment, the temperature sensor 1300A-C can communicate with the external fluid source 1200 to automatically control the flow rate of the cooling fluid, thereby automatically adjusting the body temperature of the patient. For example, the body temperature of the patient can be continuously transmitted to a control system 1202 of the external fluid source 1200. The control system 1202 can then adjust the flow rate of the cooling fluid to adjust the body temperature until a desired target body temperature is reached. Further, the control system 1202 can continually or incrementally adjust the flow rate of the cooling fluid to gradually increase or decrease the patient's body temperature as desired.

In another example embodiment, the control system 1202 can be programmed to automatically adjust the flow rate of the cooling fluid to reach a target temperature based on several factors, including but not limited to, the patient's characteristics (e.g., the patient's health history if available, the patient's physical make-up (e.g., height, weight, etc.)), environmental conditions (e.g., ambient temperature, etc.), etc.

Still referring to FIG. 14, patient information, such as but not limited to, patient's body temperature, flow rate of cooling fluid, patient's pulse, etc., may be visually displayed via a display 1204 associated with the external cooling system or printed via a printer 1206 associated with the external cooling system 1200. Further, the information may be transmitted from the control system 1202 to a remote location (e.g., medical facility) or to an electronic device 1408, such as but not limited to, a mobile phone, a tablet, a PDA, a computer, etc.

Referring to FIG. 14A, the innovative cervical collar 500 can be configured as part of a system that allows the cervical collar 500 to communicate with peripheral medical and non-medical equipment 1400A (e.g., fluid sources, thermal imaging devices (camera), temperature devices, printer, computer, etc.). Thus, the practitioner can program the peripheral equipment to set certain parameters. For example, the practitioner can program a temperature of the fluid, a flow rate of the fluid, a temperature of the patient's cerebral vascular and/or core, etc. Thus, the practitioner can easily achieve desired parameters by simply programming the peripheral equipment in use with the cervical collar 500. The

communication between the cervical collar 500 and the peripheral equipment can be wired or wireless (e.g., RF, Bluetooth, etc.).

Referring to FIG. 15, a method of using the collar 500 incorporating the bladder 506 will now be described. At 1502, the collar 500 is placed on the patient. At 1504, the sensor is properly placed to monitor the patient's temperature. At 1506, the external cooling system or source is connected to the bladder via the inlet and outlet ports 534, 536. At 1508, cooling fluid from the external cooling system or source is pumped into the bladder 506. If desired, at 1510, the cooling fluid can be continuously circulated through the bladder 506. At 1512, the patient's body temperature is monitored. At 1514, the body temperature is transmitted to the control system. At 1516, the flow rate of the cooling fluid is adjusted to regulate the patient's body temperature. At 1518, the target body temperature is achieved.

Referring to FIG. 15A, as mentioned above, in another example embodiment, the cervical collar 500 can include multiple temperature sensors to measure the patient's body (or core) temperature and the temperature of the patient's cerebral vasculature. The core temperature, the cerebral vasculature temperature, and/or the difference between the two can be used to determine if the temperature and/or flow rate of the cooling fluid should be adjusted. For example, once the cervical collar 500 is placed on the patient and the cooling fluid is circulating through the collar, at 1502A a differential threshold can be predetermined. At 1504A, the core temperature of the patient is measured and recorded. At 1506A, the temperature of the cerebral vasculature of the patient is measured and recorded. At 1508A, a temperature difference between the core temperature and the cerebral vasculature is determined. At 1510A, the temperature difference is compared to the differential threshold. If at 1512A the temperature difference does not meet the differential threshold, the process goes to 1514A and the temperature and/or the flow rate of the cooling fluid is adjusted. The process then loops back to 1504A and the process is repeated till the temperature difference meets the differential threshold. When the temperature difference meets the differential threshold then at 1512A, the process goes to 1516A and the temperature or the flow rate of the cooling fluid is not adjusted. The process then loops back to 1504A and the process is repeated to insure that the temperature difference continues to meet the differential threshold.

FIGS. 16-19 represent another example embodiment of a cervical collar 1600 (hereinafter "collar") incorporating a cooling device. The collar 1600 includes an outer shell 1602, an adjustable support (not shown), and a cooling device 1606. It is to be appreciated that while the collar 1600 can be used for inducing hypothermia, the collar 1600 can also be used as a standard cervical collar when a patient does not require therapeutic hypothermia.

Referring to FIGS. 17 and 18, the outer shell 1602 includes a front portion 1608 fixedly coupled to a back portion 1610 on one side and a fastening device 1612 attached to the back portion 1610 and removably coupling the front and back portions 1608, 1610 on an opposite side. The features of the fastening device 1612 are similar to the fastening device 108 described above and, as such, will not be repeated.

The outer shell 1602 is made from a flexible plastic material, such as but not limited to polyethylene, polystyrene, etc. Further, both the front and back portions 1608, 1610 include multiple panels 1614 each connected by hinged portions 1616 that further facilitate in the flexibility of the outer shell 1602. This configuration allows EMT

personnel to control the flexibility of the collar **1600** and easily adjust the collar **1600** to fit the patient. In addition, the flexibility characteristic allows the collar **1600** to be packaged in a flat state thereby optimizing volume space for shipping and/or storage purposes. The front portion **1608** of the outer shell **1602** further includes multiple slots **1618** and multiple recesses **1620** disposed on each side of each slot **1618**. The multiple slots **1618** and multiple recesses **1620** facilitate attachment and adjustment of the support to the collar **1600** subsequently described.

The support is used to support the patient's chin and is adjustable to conform to the patient. The support includes attachment legs that attach the support to the front portion **1608** and a connection part connecting distal ends of the attachment legs. The connection part serves to support the patient's chin. Multiple slots **1618** are defined in the front portion **1608** to receive the attachment legs to thereby connect the support to the collar **1600**. The support can be adjusted by sliding each attachment leg in each slot **1618** to a desired position. The attachment legs engage recesses **1620** defined on each side of each slot **1618** to lock the support in its desired position.

As mentioned above, the connection part provides a connection between the distal ends of the attachment legs. The connection point between the attachment legs and the connection part is hinged to facilitate packaging. Specifically, when the collar **1600** is packaged in a flat state, mentioned above, one attachment leg is disconnected from the collar **1600** and laid in a flat state. This is possible because of the hinged connection.

Referring to FIG. **19**, the cooling device **1606** includes one or more cooling packs **1630** integrated into an interior of the collar **1600**. The cooling pack(s) **1630** can be strategically disposed at essential locations on the cervical collar **1600** to target the areas of the neck described above. For example, the cooling pack(s) **1630** can be located on the front portion **1608** to target the carotid arteries and/or on the back portion **1610** to target the spinal cord area. The cooling pack(s) **1630** can be any type of cooling pack, such as but not limited to chemical pack. For example, the cooling pack(s) **1630** can be a granule-activation packet uses a fluid **1632**, such as but not limited to, water and a chemical **1634**, such as but not limited to, ammonium nitrate that when mixed together create a cooling fluid. Once the cooling packs **1630** are activated, the cervical collar **1600** can be placed on the patient to provide the desired therapeutic hypothermia to essential portions of the neck area described above.

In other embodiments, the cervical collar disclosed herein can include a marking(s) and/or be made from different colors where the markings and/or colors represent a particular attribute. For example, the marking(s) and/or color may represent a type of injury that the cervical collar should be used on, a size of the cervical collar, a cooling fluid flow rate, if the cervical collar is used as a cooling device (e.g., the color blue) or used as a warming device (e.g., the color red), etc. In addition, the cervical collar may include multiple markings or different parts of the cervical collar may be made of different colors where certain combinations of markings and/or colors (e.g., the bladder may be one color and the outer shell may be a different color) represent one or more attributes of the cervical collar, such as those listed above.

For example, as mentioned above, the cervical collar can selectively cool the cerebral vasculature relative to the whole body. Thus, the cervical collar may include markings and/or be color coded to indicate that the cervical collar can

be used to electively cool the cerebral vasculature. As medical professionals have a number of medical devices at their disposal, such as neck braces or other traditional cervical collars, the innovative cervical collar that includes markings and/or is color coded provides the medical professionals a vehicle to quickly identify the proper medical device required to treat the patient in circumstances where time is of the utmost importance.

As noted above, the innovation disclosed herein is not limited to a cervical collar to treat the neck area of a person. The innovation can be applied to any portion of the body that requires therapeutic hypothermia treatments. Thus, while a particular type of cooling device is described and illustrated, it is to be understood that alternative aspects can employ the cooling device without departing from the spirit and/or scope of the innovation.

What has been described above includes examples of the innovation. It is, of course, not possible to describe every conceivable combination of components or methodologies for purposes of describing the subject innovation, but one of ordinary skill in the art may recognize that many further combinations and permutations of the innovation are possible. Accordingly, the innovation is intended to embrace all such alterations, modifications and variations that fall within the spirit and scope of the appended claims. Furthermore, to the extent that the term "includes" is used in either the detailed description or the claims, such term is intended to be inclusive in a manner similar to the term "comprising" as "comprising" is interpreted when employed as a transitional word in a claim.

What is claimed is:

1. A system that facilitates therapeutic hypothermia comprising:
  - a cervical collar including:
    - an outer shell having a front portion and a back portion fixedly coupled to the front portion on one side and removably coupled to the front portion on an opposite side; and
    - a bladder disposed on an interior of the outer shell, wherein the bladder selectively targets blood flowing through cerebral circulation arteries thereby changing a temperature of the blood flowing through the cerebral circulation arteries to a patient's brain.
2. The system of claim **1**, wherein the cerebral circulation arteries include at least one of internal (intracranial) carotid arteries, external carotid arteries, anterior cerebellar arteries, anterior inferior cerebellar arteries, middle cerebral arteries, anterior spinal arteries, anterior communicating arteries, ophthalmic arteries, vertebral veins and arteries, subclavian arteries, basilar arteries, posterior cerebellar arteries, posterior inferior cerebellar arteries, posterior communicating arteries, pontine arteries, superior cerebellar arteries, and the posterior spinal artery.
3. The system of claim **1**, wherein the bladder includes a plurality of cooling chambers that hold cooling fluid and a plurality of passageways that fluidly connect the plurality of cooling chambers with each other.
4. The system of claim **3**, wherein the bladder further includes an inlet port and an outlet port connected to the plurality of passageways that provide a connection between a fluid source and the plurality of cooling chambers.
5. The system of claim **4**, wherein the fluid cooling source is at least one of a portable cooling pack and a continuous cooling system.
6. The system of claim **5**, wherein the portable cooling pack is connected to the inlet port and wherein field per-

sonnel manually squeeze the cooling fluid into the plurality of cooling chambers via the inlet port.

7. The system of claim 6, wherein upon arrival at a medical facility, the portable cooling pack can be removed from the inlet port and the continuous cooling system can be connected to the inlet port and the outlet port whereby cooling fluid is continuously pumped through the bladder thereby transitioning the fluid source from the portable cooling pack to the continuous cooling system.

8. The system of claim 5, wherein the continuous cooling system is connected to the inlet port and the outlet port whereby cooling fluid is continuously pumped through the bladder.

9. The system of claim 8, wherein the continuous cooling system can be removed from the inlet and outlet ports and the portable cooling pack can be connected to the inlet port thereby allowing the patient to be transferred between medical facilities.

10. A cervical collar comprising:  
 an outer shell having a front portion and a back portion fixedly coupled to the front portion on one side and removably coupled to the front portion on an opposite side;  
 a bladder configured to hold fluid disposed on an interior of the outer shell; and  
 an indicator that changes color based on a change in a measurable event, wherein the bladder is the indicator.

11. The cervical collar of claim 10, wherein the measurable event is a change in a temperature of the fluid disposed inside the bladder.

12. The cervical collar of claim 11, wherein the indicator changes in sequence from a first color to a second color, to a third color, etc. as the temperature of the fluid increases.

13. The cervical collar of claim 12, wherein the indicator changes back in sequence when the temperature of the fluid decreases.

14. The cervical collar of claim 10, wherein the measurable event is a passage of time.

15. The cervical collar of claim 14, wherein the indicator changes color each time an increment of a predetermined time passes.

16. The cervical collar of claim 10 further comprising a fastening device that removably couples the back portion to the front portion on the opposite side.

17. A method of inducing therapeutic hypothermia comprising:

- placing a cervical collar on a patient's neck;
- circulating cooling fluid through the cervical collar;
- determining a differential threshold;
- measuring the patient's core temperature;
- measuring the patient's cerebral vasculature temperature;
- determining a difference between the patient's core temperature and the patient's cerebral vasculature temperature;
- comparing the difference to the differential threshold; and
- determining if the difference meets the differential threshold.

18. The method of claim 17, wherein if the difference meets the differential threshold, the method further comprising not adjusting a temperature and a flow rate of cooling fluid.

19. The method of claim 17, wherein if the difference does not meet the differential threshold, the method further comprising adjusting a temperature and/or a flow rate of the cooling fluid.

20. The method of claim 19, wherein the temperature and/or a flow rate of the cooling fluid is adjusted until the difference meets the differential threshold.

\* \* \* \* \*

专利名称(译)	颈托		
公开(公告)号	<a href="#">US10426658</a>	公开(公告)日	2019-10-01
申请号	US15/287227	申请日	2016-10-06
[标]申请(专利权)人(译)	马赫ROBERT MICHAEL		
申请(专利权)人(译)	MAHER , ROBERT MICHAEL		
当前申请(专利权)人(译)	NEURORESCUE , LLC		
[标]发明人	MAHER ROBERT MICHAEL		
发明人	MAHER, ROBERT MICHAEL		
IPC分类号	A61B5/01 A61F7/10 A61B5/00 A61F5/055 A61F7/02 A61F7/00		
CPC分类号	A61F5/055 A61B5/6812 A61F7/10 A61B5/01 A61F7/02 A61F2007/0228 A61F2007/0056 A61F2007/0086 A61B5/4836 A61F2007/0231 A61B5/6822 A61F2007/0095 A61F2007/0225 A61F2007/0009 A61F2007/0011 A61F7/106 A61F2007/0282 A61B5/742		
代理人(译)	PINGOR , JAMES J.		
优先权	61/419018 2010-12-02 US		
其他公开文献	US20170020722A1		
外部链接	<a href="#">Espacenet</a>		

摘要(译)

提供了一种有助于治疗性低温的颈托，该颈托包括具有前部和后部的外壳，该前部和后部在一侧固定地连接到该前部并且在相对侧上可移除地连接到该前部。紧固装置在相对侧上将后部可移除地联接到前部。在外壳的内部上设置至少一个冷却装置以在患者体内引起体温过低。提供了一种传感器，该传感器测量患者的身体特征。

