



US010165954B2

(12) **United States Patent**  
**Lee**

(10) **Patent No.:** **US 10,165,954 B2**  
(45) **Date of Patent:** **Jan. 1, 2019**

(54) **INTEGRATED SENSOR MODULES**

(71) Applicant: **Salutron, Inc.**, Fremont, CA (US)

(72) Inventor: **Yong Jin Lee**, Seoul (KR)

(73) Assignee: **SALUTRON INC.**, Newark, CA (US)

(\* ) Notice: Subject to any disclaimer, the term of this patent is extended or adjusted under 35 U.S.C. 154(b) by 486 days.

(21) Appl. No.: **14/661,819**

(22) Filed: **Mar. 18, 2015**

(65) **Prior Publication Data**

US 2016/0029911 A1 Feb. 4, 2016

**Related U.S. Application Data**

(60) Provisional application No. 62/031,813, filed on Jul. 31, 2014, provisional application No. 62/058,492, filed on Oct. 1, 2014.

(51) **Int. Cl.**  
**A61B 5/024** (2006.01)  
**H01L 25/16** (2006.01)  
(Continued)

(52) **U.S. Cl.**  
CPC ..... **A61B 5/02427** (2013.01); **A61B 5/0205** (2013.01); **A61B 5/02416** (2013.01);  
(Continued)

(58) **Field of Classification Search**  
CPC ..... **A61B 5/02427**; **A61B 5/0205**; **A61B 5/02416**; **A61B 5/0537**; **A61B 5/681**;  
(Continued)

(56) **References Cited**

U.S. PATENT DOCUMENTS

4,470,009 A \* 9/1984 Takayanagi ..... G01R 29/24  
324/457  
5,473,949 A \* 12/1995 Cage ..... G01F 1/8409  
73/32 A

(Continued)

OTHER PUBLICATIONS

Global Semiconductor Alliance, "Embedded Die Packaging Technologies Enable Innovative 2D and 3D Structures for Portable Applications", Innovator Update: Supplier Edition, vol. 21, No. 1, Mar. 2014.

*Primary Examiner* — Jessandra Hough

(74) *Attorney, Agent, or Firm* — Vierra Magen Marcus LLP

(57) **ABSTRACT**

An integrated sensor module includes one or more packaged light source semiconductor devices and one or more packaged light detector semiconductor devices mounted to a top surface of a substrate. A pre-molded cover structure includes a portion molded from an opaque molding compound and a further portion molded from a light transmissive molding compound. For each of the packaged light source and light detector semiconductor devices, the pre-molded cover structure includes a pre-molded cavity covered by a window formed of the light transmissive molding compound. The pre-molded cover structure is attached to the substrate such that each of the packaged light source and light detector semiconductor devices fits within a respective cavity, and such that a barrier formed of the opaque molding compound is positioned between each packaged light source semiconductor device and light detector semiconductor device. The module can also include additional sensors and/or electrodes for use by sensors.

**19 Claims, 14 Drawing Sheets**

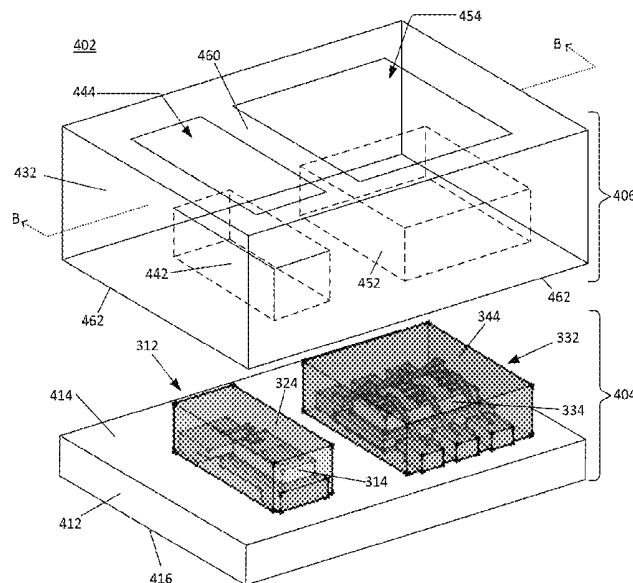

- (51) **Int. Cl.**  
*A61B 5/00* (2006.01)  
*A61B 5/0205* (2006.01)  
*A61B 5/053* (2006.01)  
*A61B 5/0245* (2006.01)
- (52) **U.S. Cl.**  
 CPC ..... *A61B 5/0537* (2013.01); *A61B 5/681*  
 (2013.01); *H01L 25/167* (2013.01); *A61B*  
*5/0245* (2013.01); *A61B 5/0531* (2013.01);  
*H01L 2224/32245* (2013.01); *H01L*  
*2224/48091* (2013.01); *H01L 2224/48247*  
 (2013.01); *H01L 2224/73265* (2013.01)
- (58) **Field of Classification Search**  
 CPC ... *A61B 5/0245*; *A61B 5/0531*; *H01L 25/167*;  
*H01L 2224/32245*; *H01L 2224/48091*;  
*H01L 2224/48247*; *H01L 2224/73265*  
 See application file for complete search history.
- (56) **References Cited**  
 U.S. PATENT DOCUMENTS  
 5,678,544 A \* 10/1997 DeLonzor ..... *A61B 5/02427*  
 351/41  
 6,420,818 B1 \* 7/2002 Kishimoto ..... *H04R 7/20*  
 310/324  
 7,590,439 B2 \* 9/2009 Raridan ..... *A61B 5/14552*  
 600/344  
 8,035,079 B2 10/2011 Hane  
 8,677,605 B2 3/2014 Lim et al.  
 9,136,236 B2 \* 9/2015 Starkston ..... *H01L 23/5385*  
 9,392,946 B1 \* 7/2016 Sarantos ..... *A61B 5/14552*  
 2006/0237540 A1 10/2006 Saxena et al.  
 2010/0181578 A1 7/2010 Li et al.  
 2010/0282951 A1 11/2010 Costello et al.  
 2014/0021491 A1 \* 1/2014 Meng ..... *H01L 33/54*  
 257/82  
 2014/0358012 A1 \* 12/2014 Richards ..... *A61B 5/02438*  
 600/479  
 2015/0323360 A1 \* 11/2015 Doi ..... *G01F 1/692*  
 73/204.26
- \* cited by examiner

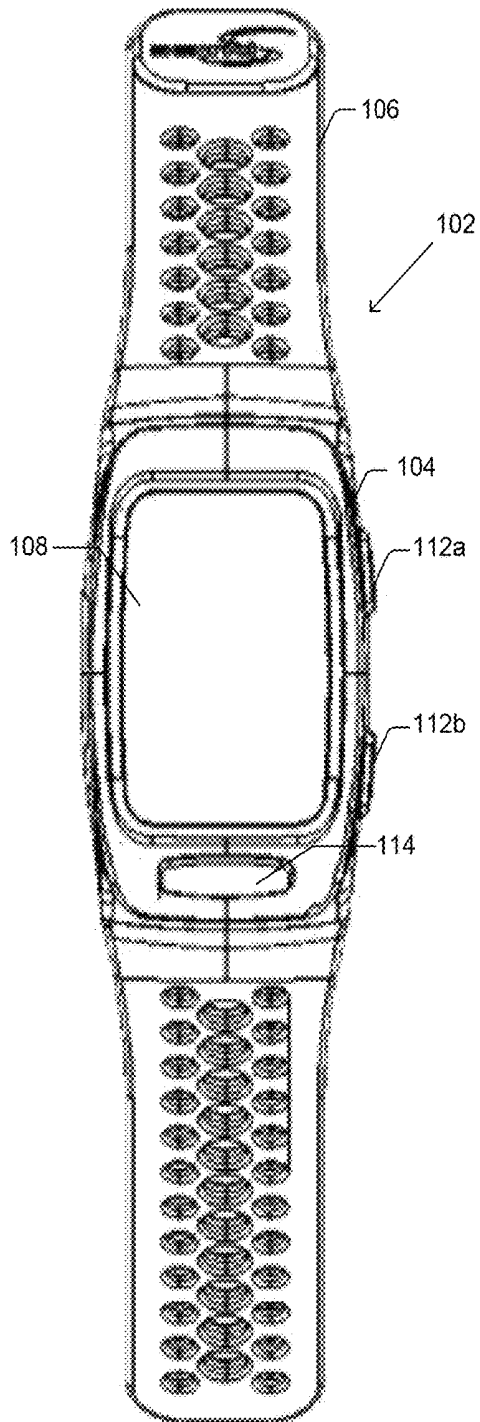

**FIG. 1A**

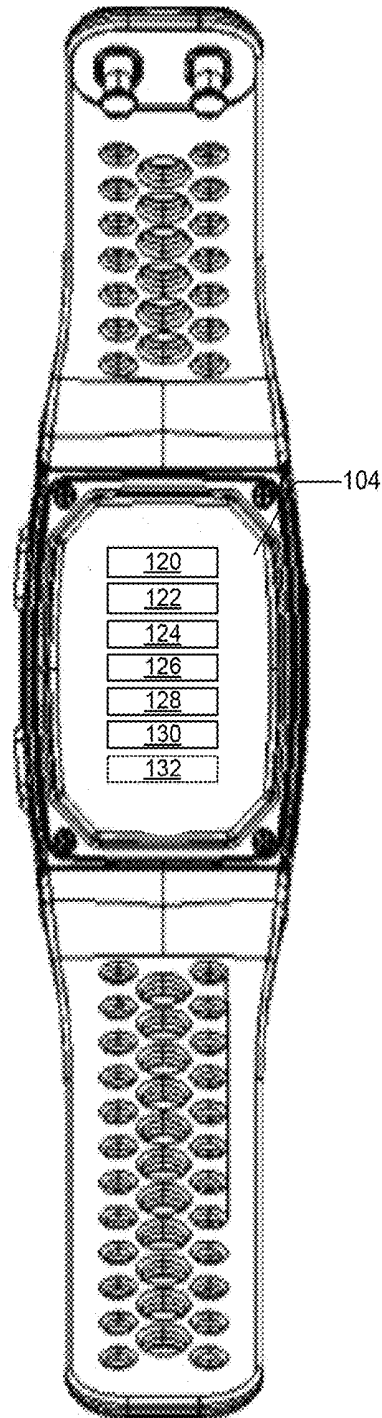

**FIG. 1B**

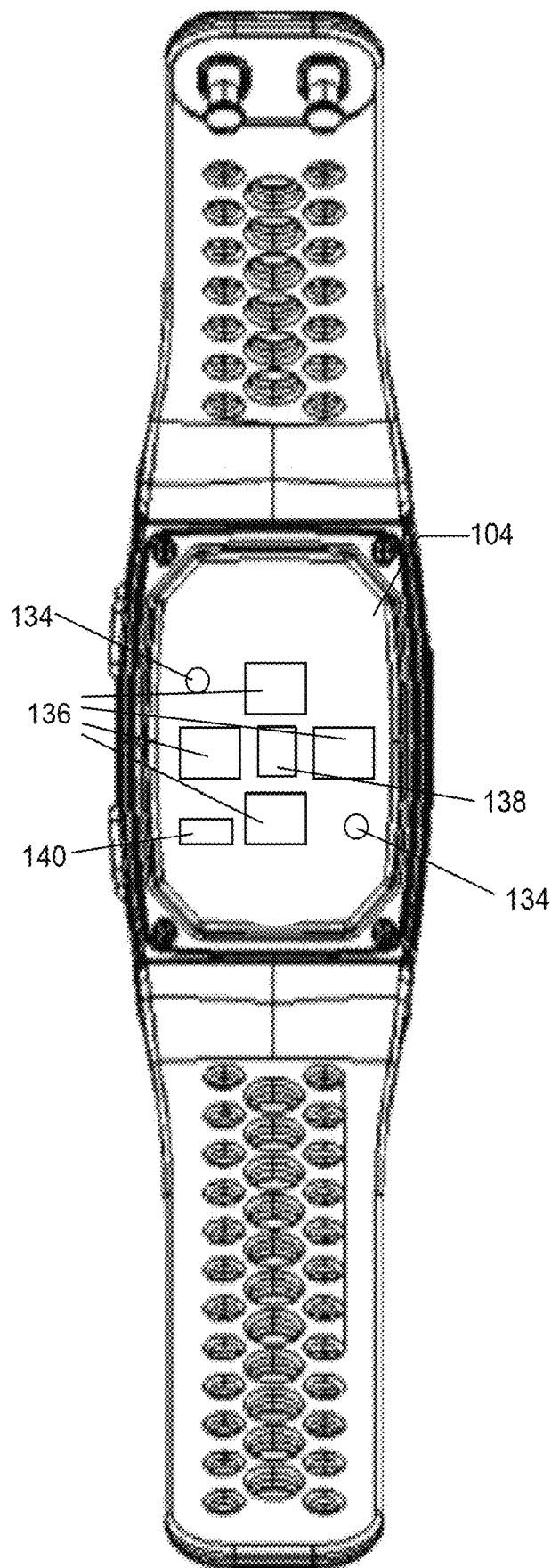

**FIG. 1C**

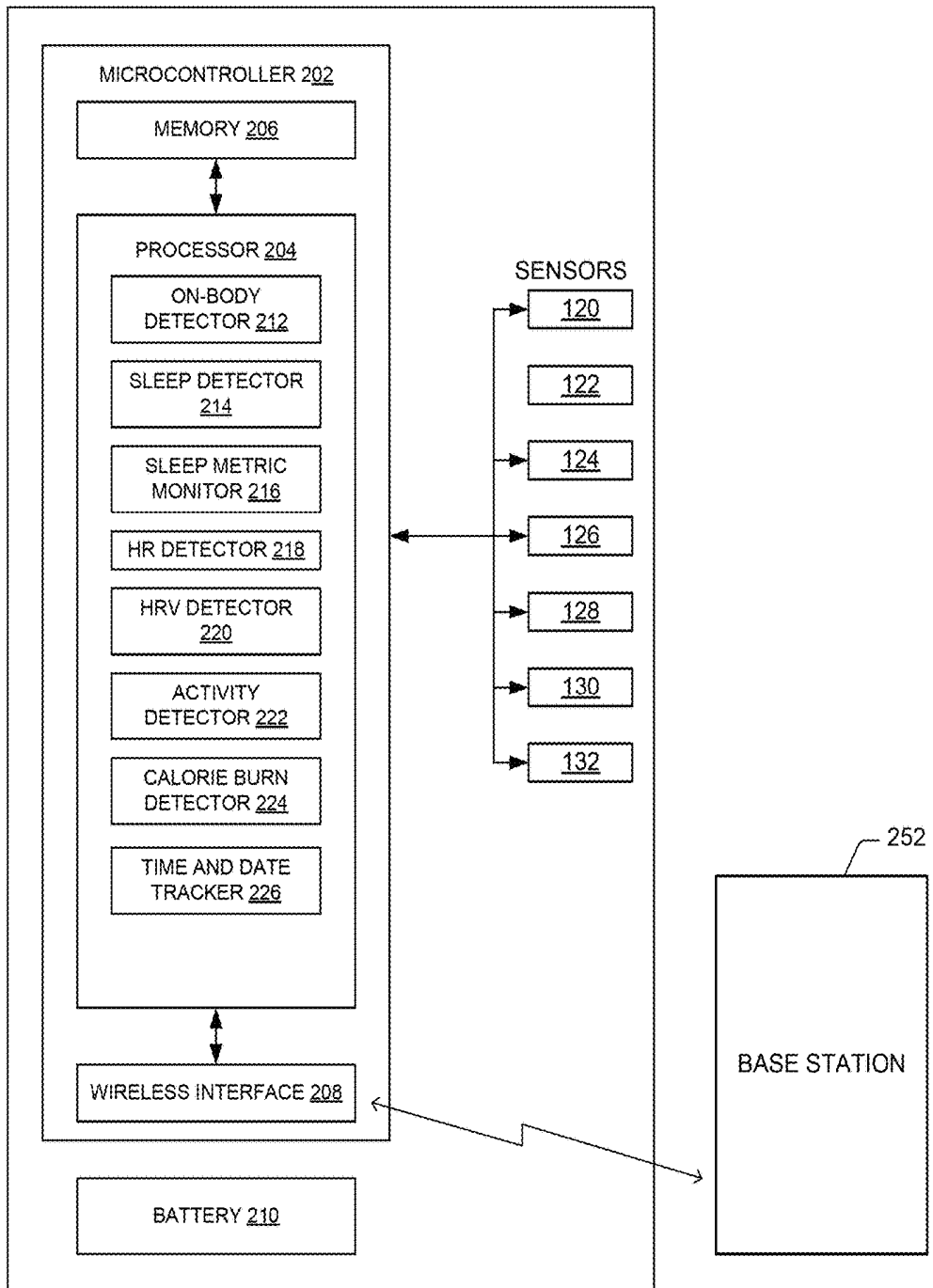

FIG. 2

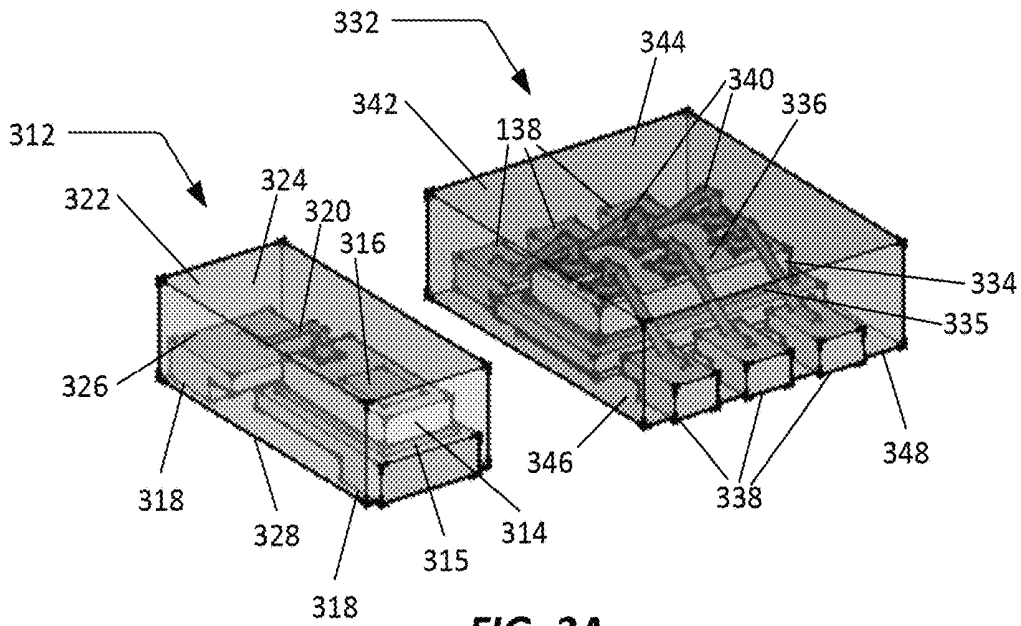

FIG. 3A

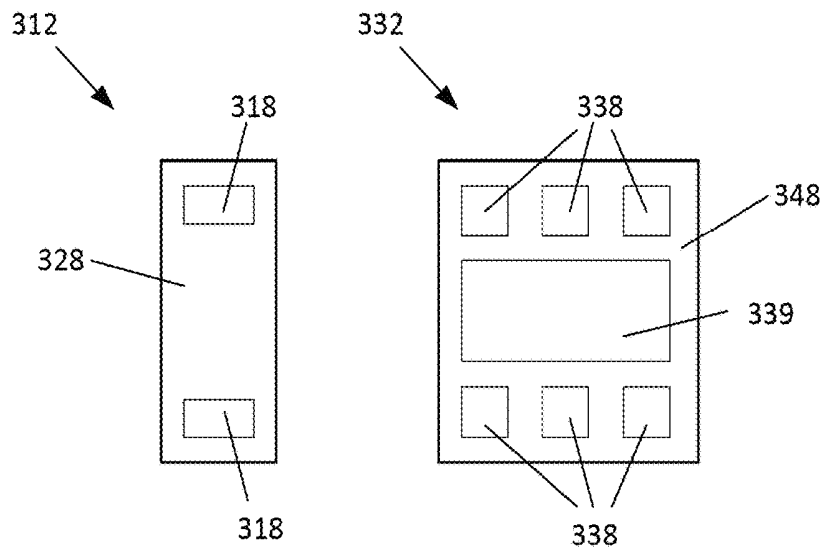

FIG. 3B

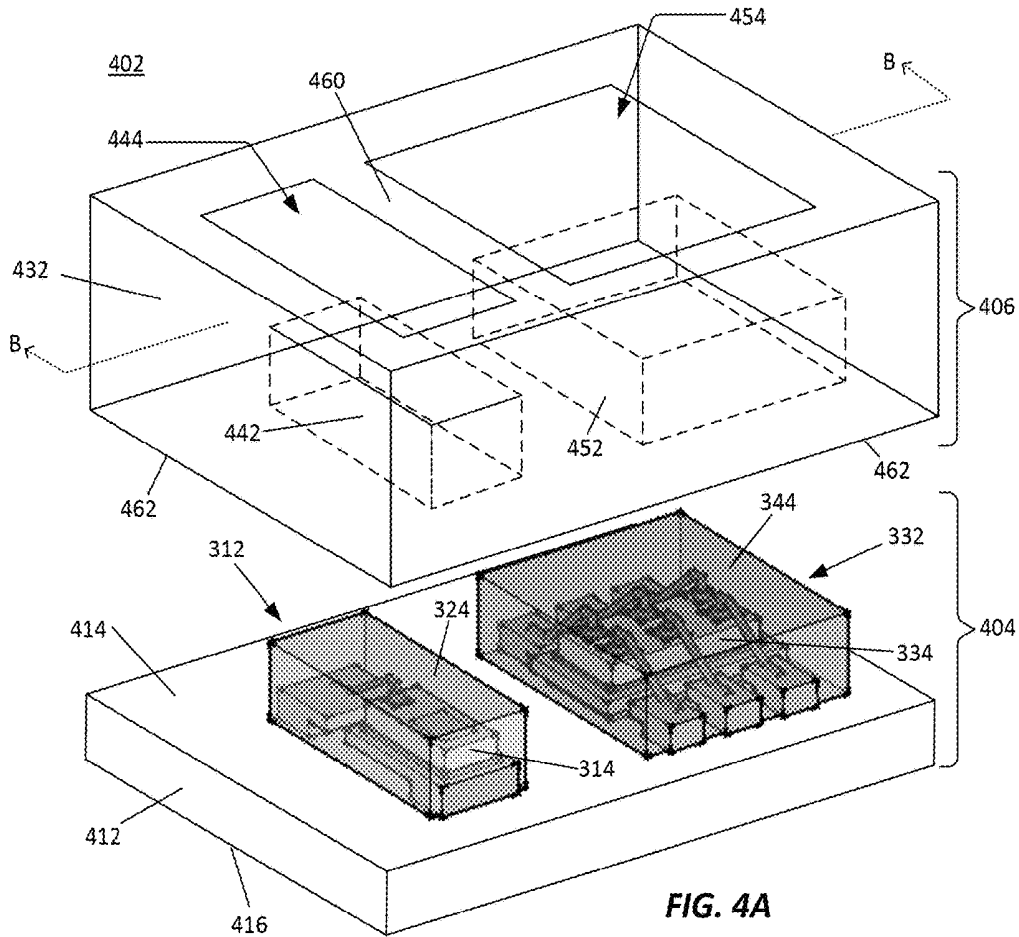

FIG. 4A

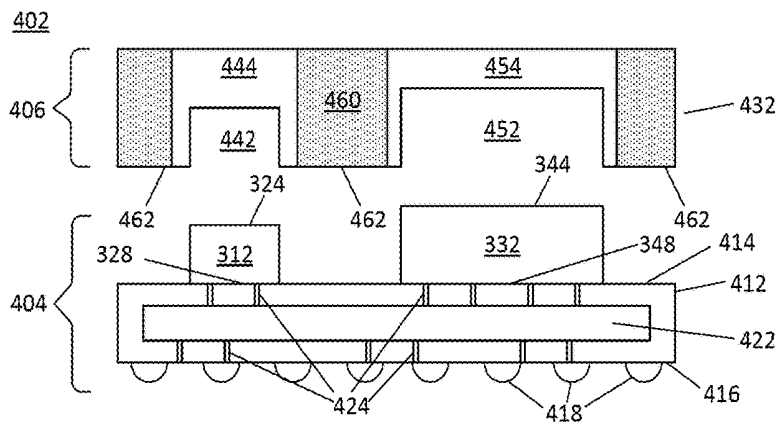

FIG. 4B

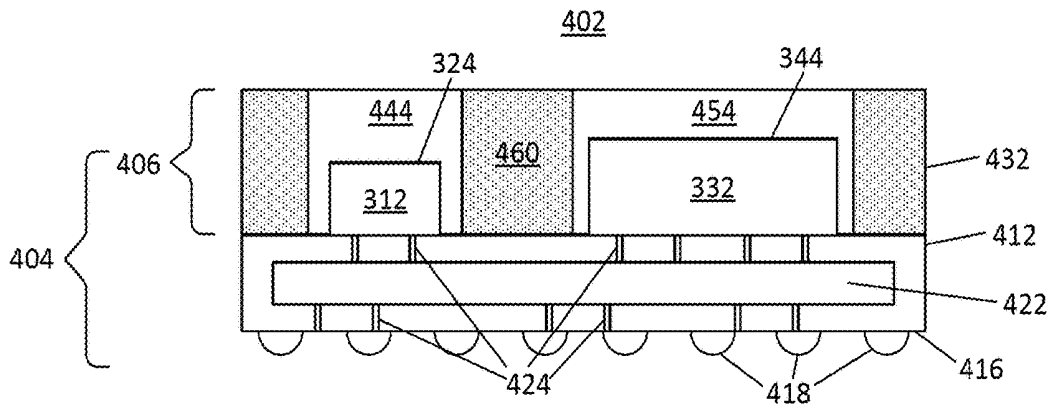

FIG. 4C

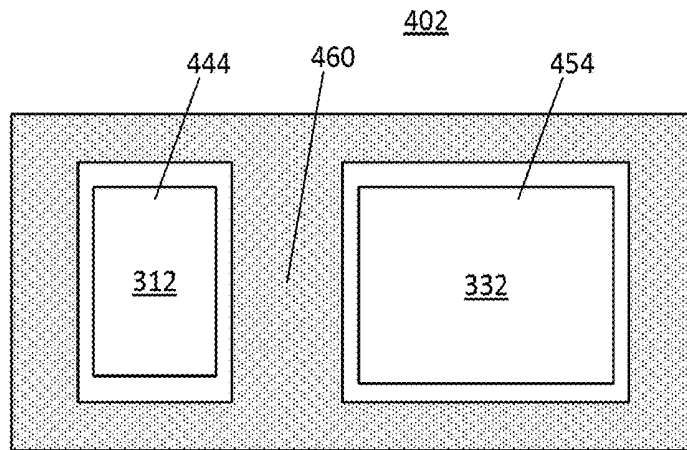

FIG. 4D

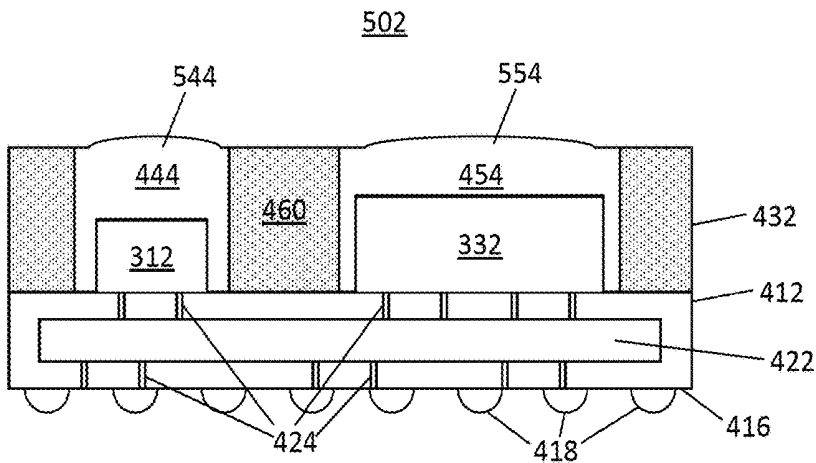

FIG. 5

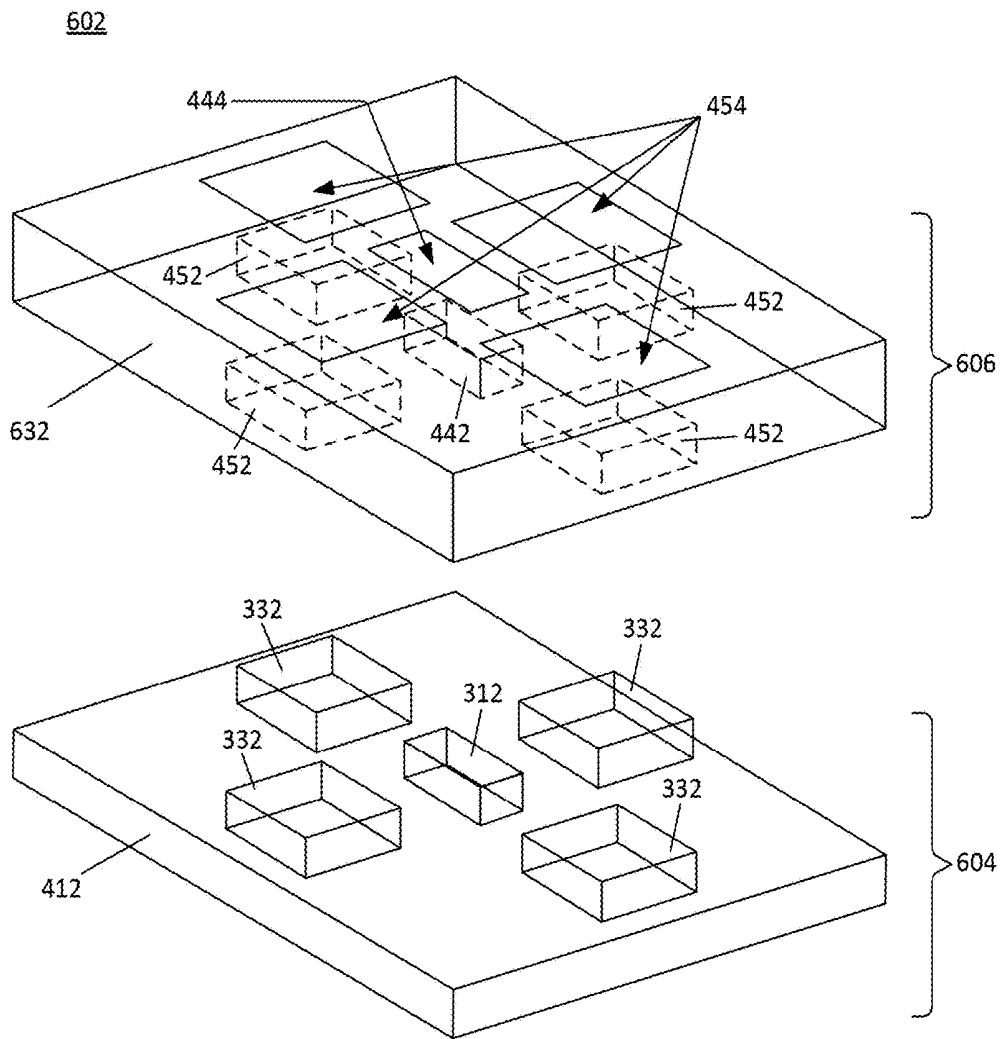
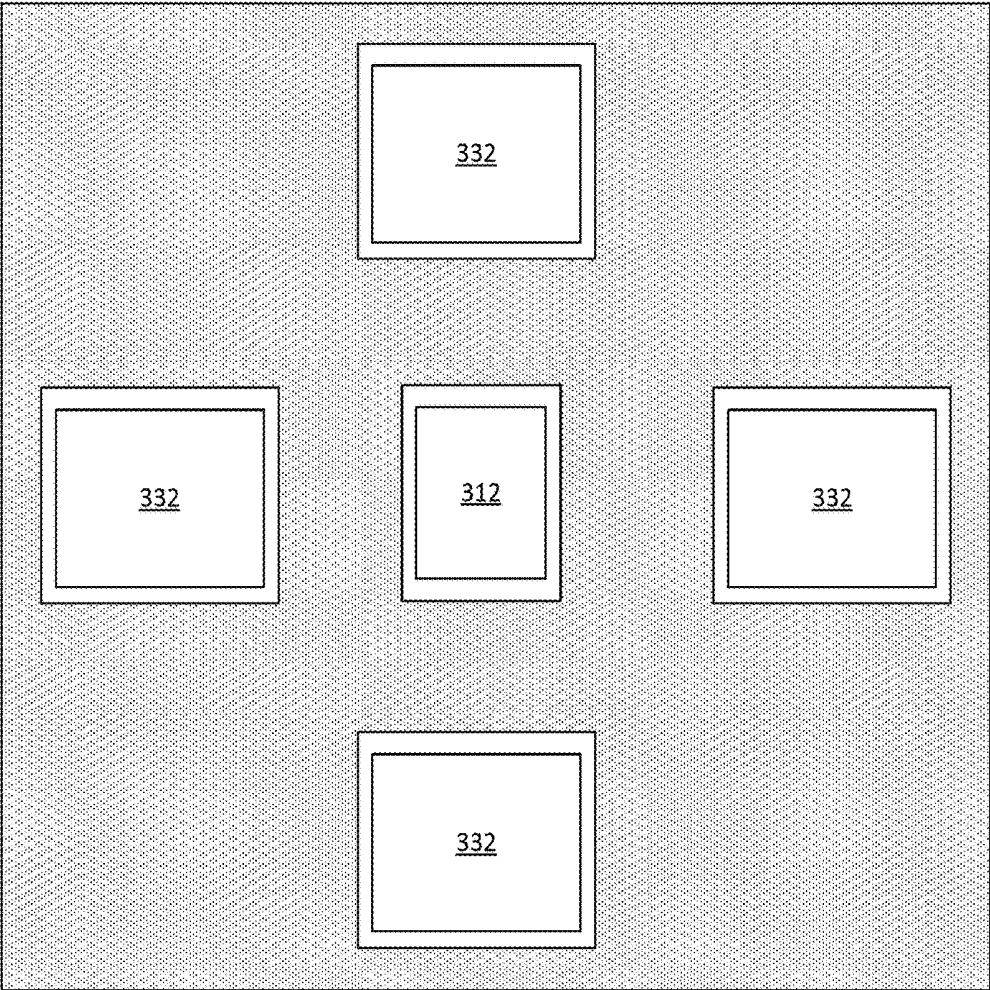
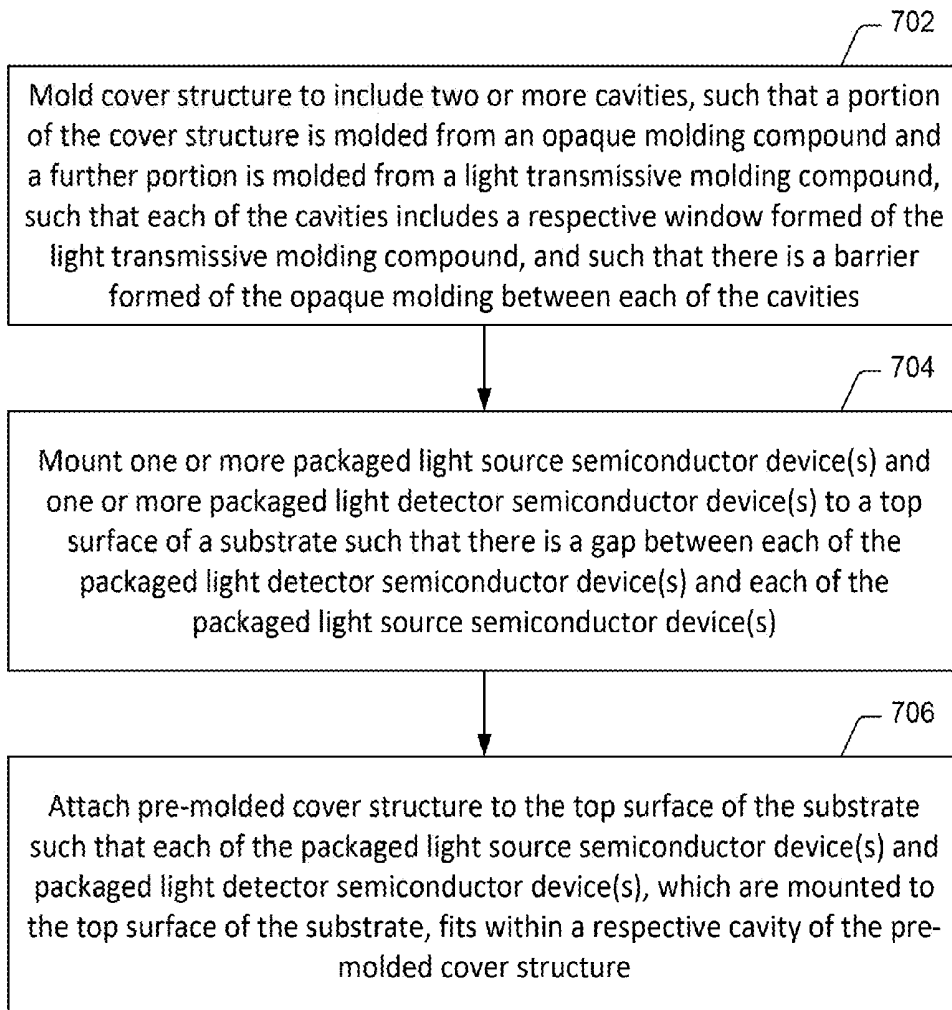

FIG. 6A

602



**FIG. 6B**

**FIG. 7**

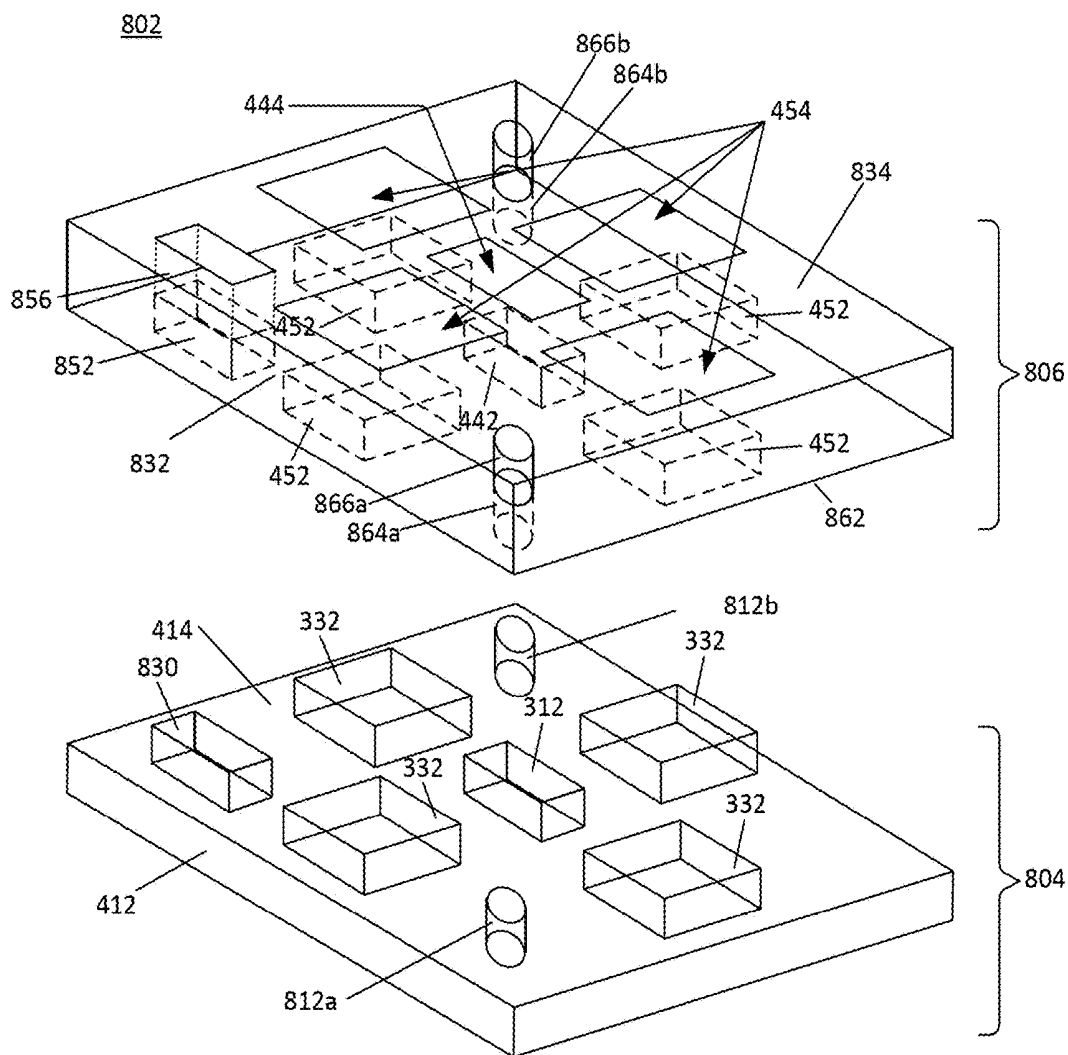
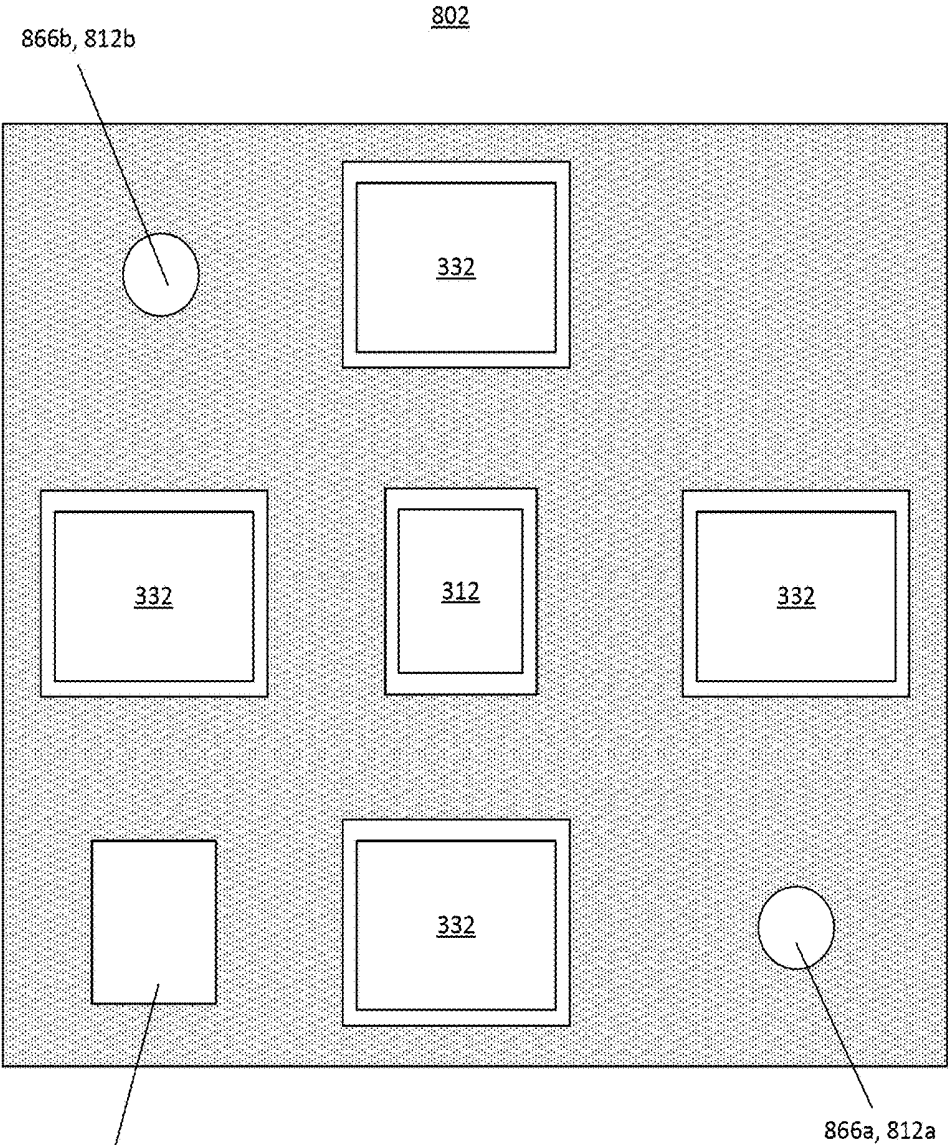

FIG. 8A



**FIG. 8B**

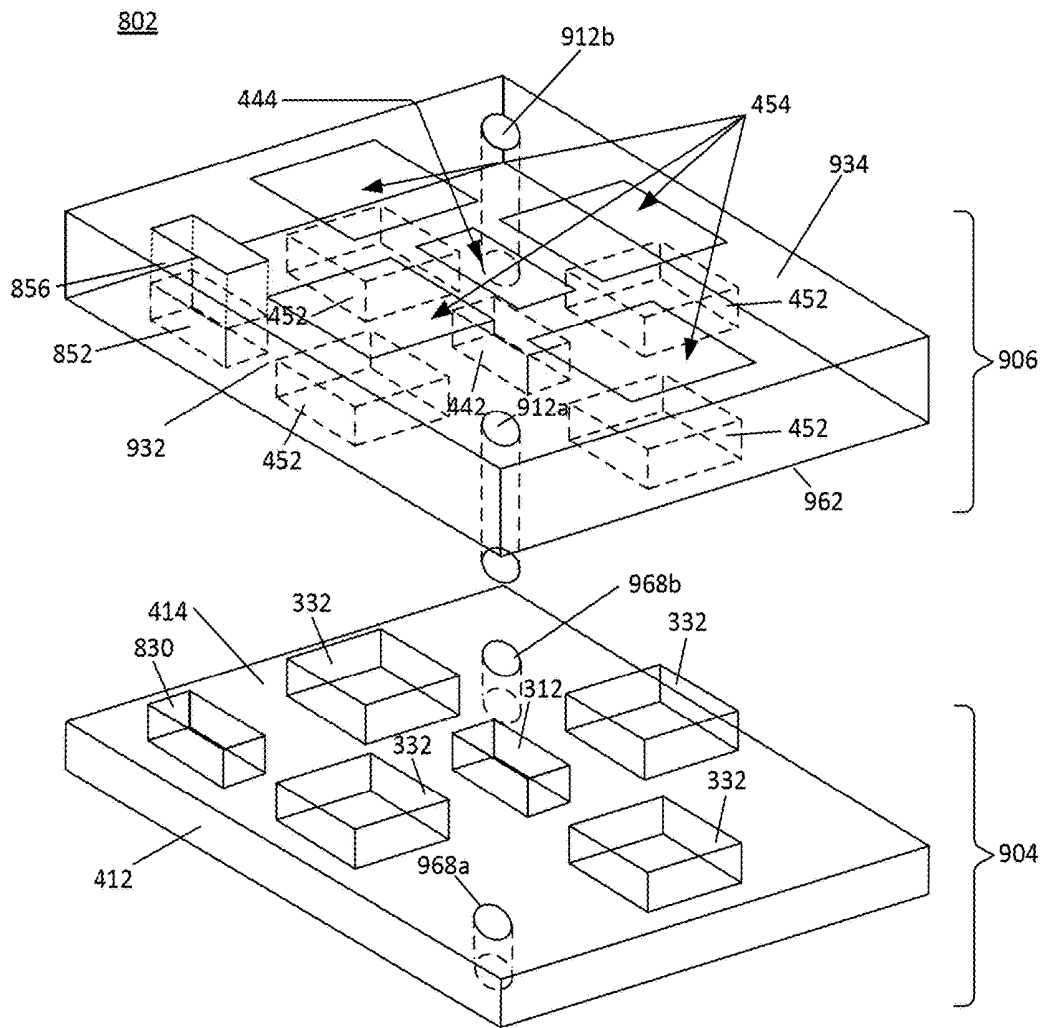

FIG. 9A

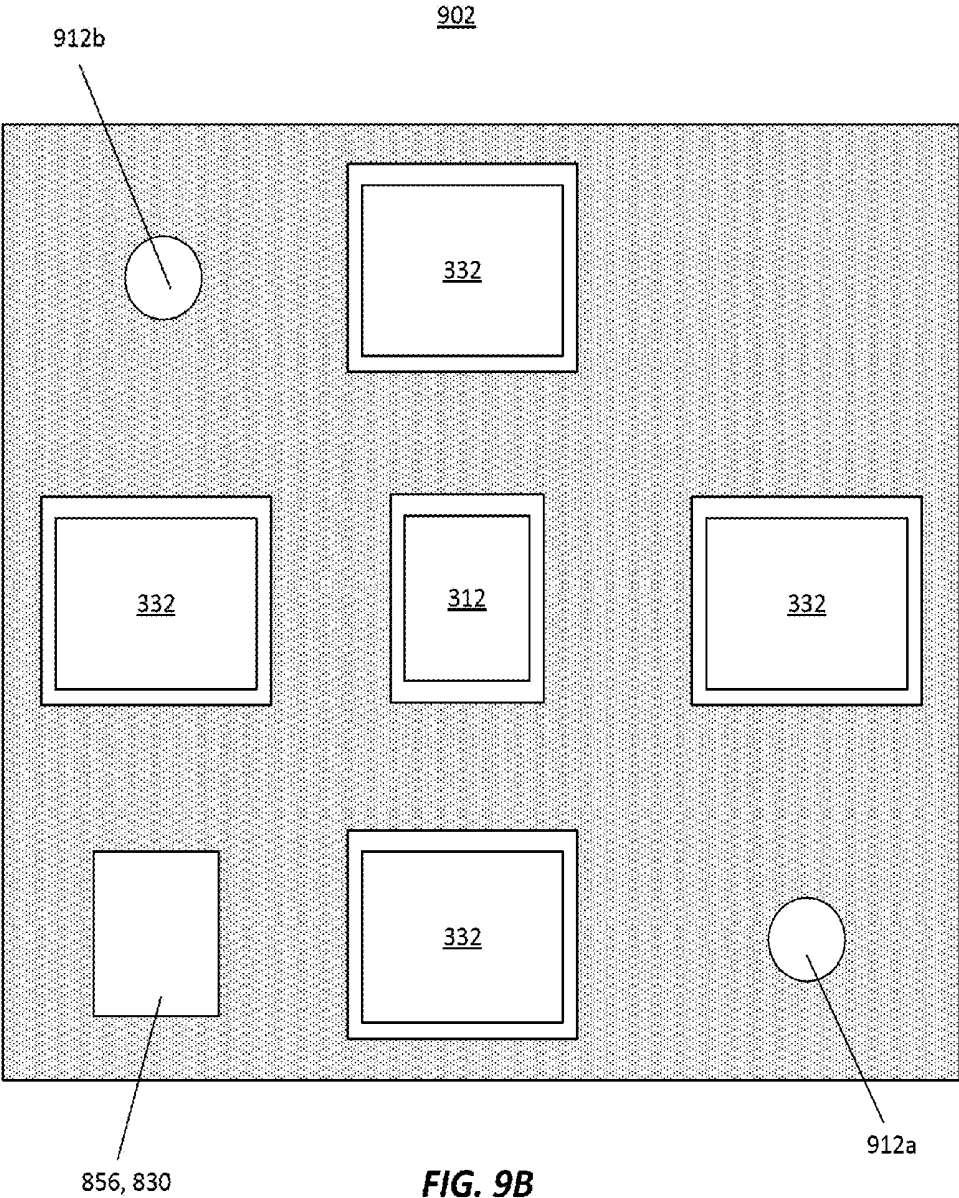

FIG. 9B

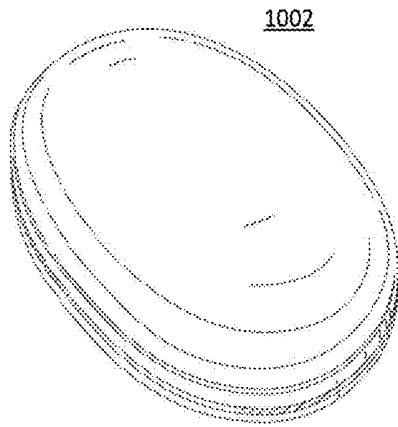

FIG. 10A

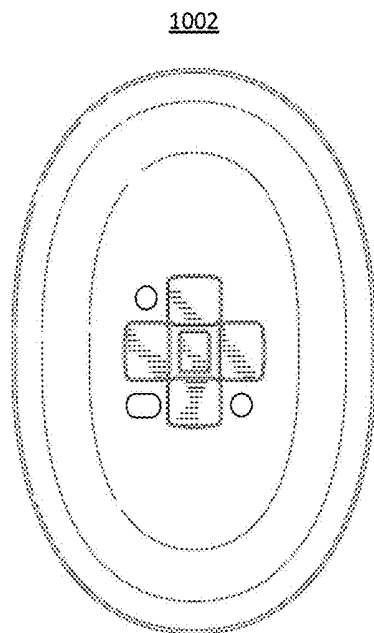

FIG. 10B

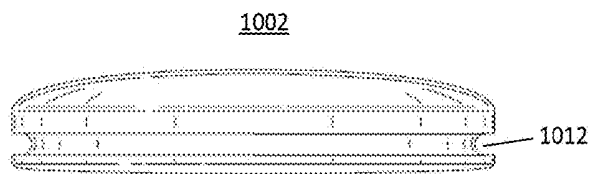

FIG. 10C

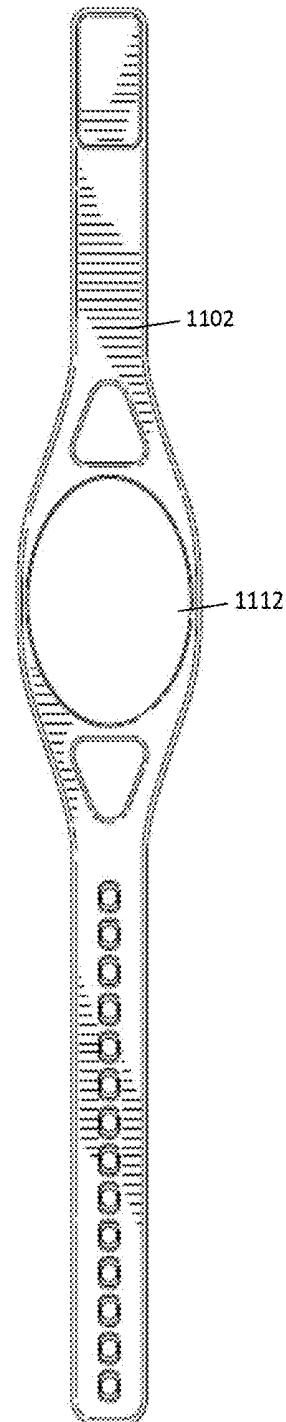

FIG. 11

## INTEGRATED SENSOR MODULES

## PRIORITY CLAIM

This application claims priority to U.S. Provisional Patent Application No. 62/031,813, filed Jul. 31, 2014, and U.S. Provisional Patent Application No. 62/058,492, filed Oct. 1, 2014, each of which is incorporated herein by reference.

## BACKGROUND

Sensors are being included in more and more products, including but not limited to user-wearable devices. For example, an optical sensor that includes a light source and a light detector may be included in a wrist-worn health and/or activity monitor, wherein the optical sensor operate as photoplethysmography (PPG) sensor that enables the wrist-worn monitor to measure heart rate (HR) and heart rate variability (HRV) of the person wearing the monitor on their wrist. For another example, an optical sensor may be included in a smart phone, wherein the optical sensor operates as a proximity sensor that can be used to determine when the phone is being held close to a persons' ear, in response to which a touchscreen of the phone is disabled so that functions are not accidentally triggered if the person's ear touches the touchscreen. With such optical sensors, it is desirable to reduce and preferably minimize or eliminate optical crosstalk. Additionally, it is desirable that such optical sensors are compact, since they are often included in portable devices in which small size and light weight are preferred. Similarly, for other types of sensors it is typically desirable that they are compact, especially when included in portable devices.

## BRIEF DESCRIPTION OF THE DRAWINGS

FIG. 1A depicts a front view of a user-wearable device, according to an embodiment.

FIG. 1B depicts a rear view of the user-wearable device of FIG. 1A, according to an embodiment.

FIG. 1C depicts a specific implementation of contact sensors that are viewable from the rear or caseback of the user-wearable device of FIGS. 1A and 1B, according to an embodiment.

FIG. 2 depicts a high level block diagram of electrical components of the user-wearable device introduced in FIGS. 1A, 1B and 1C, according to an embodiment.

FIG. 3A shows a perspective view of an exemplary packaged light source semiconductor device (PLSSD), and a perspective view of an exemplary packaged light detector semiconductor device (PLDSD), which may be parts of the optical sensor included in the user-wearable device of FIGS. 1A, 1B and 2.

FIG. 3B shows a bottom view of the exemplary PLSSD shown in FIG. 3A, and a bottom view of the exemplary PLDSD shown in FIG. 3A.

FIG. 4A is top perspective view of two subassemblies of an integrated sensor module, according to an embodiment of the present technology, before the two subassemblies are attached to one another.

FIG. 4B is a cross section of the two subassemblies shown in FIG. 4A.

FIG. 4C is a cross section of the two subassemblies shown in FIGS. 4A and 4B after they have been attached to one another.

FIG. 4D is a top view of the integrated sensor module after the two subassemblies shown in FIGS. 4A and 4B have been attached to one another.

FIG. 5 is a cross section of an integrated sensor module that is similar to the one shown in FIGS. 4A-4D, but includes windows having lenses.

FIG. 6A is top perspective view of two subassemblies of an integrated sensor module, according to another embodiment of the present technology, before the two subassemblies are attached to one another.

FIG. 6B is a top view of the integrated sensor module introduced in FIG. 6A after the two subassemblies shown in FIG. 6A have been attached to one another.

FIG. 7 is a high level flow diagram of a method for manufacturing integrated sensor module according to an embodiment of the present technology.

FIG. 8A is top perspective view of two subassemblies of an integrated sensor module, according to another embodiment of the present technology, before the two subassemblies are attached to one another.

FIG. 8B is a top view of the integrated sensor module introduced in FIG. 8A after the two subassemblies shown in FIG. 8A have been attached to one another.

FIG. 9A is top perspective view of two subassemblies of an integrated sensor module, according to another embodiment of the present technology, before the two subassemblies are attached to one another.

FIG. 9B is a top view of the integrated sensor module introduced in FIG. 9A after the two subassemblies shown in FIG. 9A have been attached to one another.

FIGS. 10A, 10B and 10C are, respectively, perspective, rear and side views of a physiological sensor pod according to an embodiment that can include an integrated sensor module.

FIG. 11 illustrates a wrist band including an opening into which the physiological sensor pod introduced in FIGS. 10A, 10B and 10C can be placed.

## DETAILED DESCRIPTION

In the following detailed description, reference is made to the accompanying drawings that form a part hereof, and in which is shown by way of illustration specific illustrative embodiments. It is to be understood that other embodiments may be utilized and that mechanical and electrical changes may be made. The following detailed description is, therefore, not to be taken in a limiting sense. In the description that follows, like numerals or reference designators will be used to refer to like parts or elements throughout. In addition, the first digit of a reference number identifies the drawing in which the reference number first appears.

Before describing integrated sensor modules of the present technology, it is first useful to describe an exemplary user-wearable device that can include an integrated sensor module. FIG. 1A depicts a front view of a user-wearable device **102**, according to an embodiment. The user-wearable device **102** can be a standalone device which gathers and processes data and displays results to a user. Alternatively, the user-wearable device **102** can wirelessly communicate with a base station (**252** in FIG. 2), which can be a mobile phone, a tablet computer, a personal data assistant (PDA), a laptop computer, a desktop computer, or some other computing device that is capable of performing wireless communication. The base station can, e.g., include a health and fitness software application and/or other applications, which can be referred to as apps. The user-wearable device **102** can upload data obtained by the device **102** to the base station,

so that such data can be used by a health and fitness software application and/or other apps stored on and executed by the base station.

The user-wearable device **102** is shown as including a housing **104**, which can also be referred to as a case **104**. A band **106** is shown as being attached to the housing **104**, wherein the band **106** can be used to strap the housing **104** to a user's wrist or arm. Where the user-wearable device **102** includes the wrist type band **106**, the device **102** can also be referred to as a wrist-wearable or wrist-worn device. The band can alternatively be configured to strap the housing **104** to the user's chest so that sensors and/or electrodes (of or for use by the sensors) are in contact with the skin on the user's chest. A front side of the housing **104** is shown as including a digital display **108**, which can also be referred to simply as a display. The digital display **108** can be used to show the time, date, day of the week and/or the like. The digital display **108** can also be used to display activity and/or physiological metrics, such as, but not limited to, heart rate (HR), heart rate variability (HRV), calories burned, steps taken and distance walked and/or run. The digital display **108** can also be used to display sleep metrics, examples of which are discussed below. Additionally, the digital display **108** can be used to display user notifications that inform a person wearing the user-wearable device to adjust their exposure to light. These are just a few examples of the types of information that may be displayed on the digital display **108**, which are not intended to be all encompassing. As the terms are used herein, the terms user and person are used interchangeably.

The housing **104** is further shown as including buttons **112a**, **112b**, which can individually be referred to as a button **112**, and can collectively be referred to as the buttons **112**. One of the buttons **112** can be a mode select button, while another one of the buttons **112** can be used to start and stop certain features. While the user-wearable device **102** is shown as including two buttons **112**, more or less than two buttons can be included. The buttons **112** can additionally or alternatively be used for other functions. The housing **104** is further shown as including a forward facing ECG electrode **114**, which is discussed below. This ECG electrode **114** can also function as an additional button. While the shapes of the housing **104** and the digital display **108** are shown as generally being rectangular, they can alternatively have other shapes, such as, but not limited to, circular or oval shapes.

In certain embodiments, the user-wearable device **102** can receive alerts from a base station (e.g., **252** in FIG. 2), or can generate its own alerts. For example, where the base station **252** is a mobile phone, the user wearable device **100** can receive alerts from the base station, which can be displayed to the user on the display **108**. For a more specific example, if a mobile phone type of base station **252** is receiving an incoming phone call, then an incoming phone call alert can be displayed on the digital display **108** of the mobile device, which may or may not include the phone number and/or identity of the caller. Other types of alerts include, e.g., text message alerts, social media alerts, calendar alerts, medication reminders and exercise reminders, but are not limited thereto. Still other types of alerts can inform a user that they should adjust their exposure to light, as will be described in additional detail below. Such alerts can be generated solely by the user-wearable device **102**, or with the assistance of a base station (e.g., **252**) with which the user-wearable device **102** wirelessly communicates. The user-wearable device **102** can inform the user of a new alert by vibrating and/or emitting an audible sound.

FIG. 1B illustrates an exemplary rear-view of the housing or case **104** of the user-wearable device **102**. Referring to FIG. 1B, the backside of the housing **104**, which can also be referred to as a caseback, is schematically shown as including a bioimpedance analysis (BIA) sensor, an optical sensor **122**, a capacitive sensor **124**, a galvanic skin resistance (GSR) sensor **126**, an electrocardiogram (ECG) sensor **128** and a skin temperature sensor **130**. It is also possible that the user-wearable device **102** includes less sensors than shown, more sensors than shown and/or alternative types of sensors. For example, the user-wearable device **102** can also include one or more type of motion sensor **132**, which is shown in dotted line because it is likely completely encased with the housing **104**.

In accordance with an embodiment, the bioimpedance analysis (BIA) sensor **120**, which can include or connect to a pair of electrodes spaced apart from one another such that a patient's skin can complete a circuit between the electrodes, passes a current at a single frequency, or more preferably at multiple frequencies, through a user's tissue (proximate the sensor electrodes) and measures impedance. Based on these impedance measurements, algorithms, linear regression models and/or other mathematical modeling can be used to calculate the user's body water content and/or body fat percentage.

In accordance with an embodiment, the optical sensor **122** includes both a light source and a light detector, in which case the optical sensor **122** can be used to detect proximity of an object (e.g., a user's wrist or chest) relative to the optical sensor, as well as to detect ambient light. The light source of the optical sensor **122** can include one or more light emitting diode (LED), incandescent lamp or laser diode, but is not limited thereto. While infrared (IR) light sources are often employed in optical sensors, because the human eye cannot detect IR light, the light source can alternatively produce light of other wavelengths. The light detector of the optical sensor **122** can include one or more one or more photoresistor, photodiode, phototransistor, photodarlington or avalanche photodiode, but is not limited thereto. When operating as an optical proximity sensor, the light source of the optical sensor **122** is driven to emit light. If an object (e.g., a user's wrist or chest) is within the sense region of the optical sensor **122**, a large portion of the light emitted by the light source will be reflected off the object and will be incident on the light detector. The light detector generates a signal (e.g., a current) that is indicative of the intensity and/or phase of the light incident on the light detector, and thus, can be used to detect the presence of the user's wrist or chest. The optical sensor **122** may also use its light detector to operate as an ambient light detector. It is also possible that the optical sensor **122** not include a light source, in which case the optical sensor **122** can operate as an ambient light sensor, but not a proximity sensor. When operating as an ambient light sensor, the optical sensor **122** produces a signal having a magnitude that is dependent on the amount of ambient light that is incident on the optical sensor **122**. It is expected that when a user is wearing the user-wearable device **102** on their wrist or chest, the light detector of the optical sensor **122** will be blocked (by the user's wrist or chest) from detecting ambient light, and thus, the signal produced the light detector will have a very low magnitude.

In accordance with specific embodiments, the optical sensor **122** can also be used to detect heart rate (HR) and heart rate variability (HRV). More specifically, the optical sensor **122** can operate as a photoplethysmography (PPG) sensor. When operating as a PPG sensor, the light source of

the optical sensor **122** emits light that is reflected or back-scattered by patient tissue, and reflected/backscattered light is received by the light detector of the optical sensor **122**. In this manner, changes in reflected light intensity are detected by the light detector, which outputs a PPG signal indicative of the changes in detected light, which are indicative of changes in blood volume. The PPG signal output by the light detector can be filtered and amplified, and can be converted to a digital signal using an analog-to-digital converter (ADC), if the PPG signal is to be analyzed in the digital domain. Each cardiac cycle in the PPG signal generally appears as a peak, thereby enabling the PPG signal to be used to detect peak-to-peak intervals, which can be used to calculate heart rate (HR) and heart rate variability (HRV). In accordance with certain embodiments, described below, a PPG signal sensed using the optical sensor **122** is used to determine whether or not to authenticate a user. In accordance with certain embodiments, the optical sensor **122** includes a light source that emits light of two different wavelengths that enables the optical sensor **122** to be used as a pulse oximeter, in which case the optical sensor **122** can non-invasively monitor the arterial oxygen saturation of a user wearing the user-wearable device **102**.

In accordance with an embodiment, the capacitive sensor **124** includes or connects to an electrode that functions as one plate of a capacitor, while an object (e.g., a user's wrist or chest) that is in close proximity to the capacitive sensor **124** functions as the other plate of the capacitor. The capacitive sensor **124** can indirectly measure capacitance, and thus proximity, e.g., by adjusting the frequency of an oscillator in dependence on the proximity of an object relative to the capacitive sensor **124**, or by varying the level of coupling or attenuation of an AC signal in dependence on the proximity of an object relative to the capacitive sensor **124**.

The galvanic skin resistance (GSR) sensor **126**, which can include or connect to a pair of electrodes spaced apart from one another such that a patient's skin can complete a circuit between the electrodes, senses a galvanic skin resistance. The galvanic skin resistance measurement will be relatively low when a user is wearing the user-wearable device **102** on their wrist or chest and the GSR sensor **126** is in contact with the user's skin. By contrast, the galvanic skin resistance measurement will be very high when a user is not wearing the user-wearable device **102** and the GSR sensor **126** is not in contact with the user's skin. The galvanic skin resistance measurement, which can also be referred to as a galvanic skin response, may also vary based on levels perspiration.

The ECG sensor **128** can be used to sense an ECG signal from a user that is wearing the user-wearable device **102** on their wrist or chest. If the user-wearable device **102** is worn on the user's wrist, then an ECG signal can be sensed when an electrode on the caseback of the housing **104** is in contact with the skin on the user's wrist, and the user's touches the forward facing electrode **114** using a finger on their other arm. If the user-wearable device **102** is worn on the user's chest, then an ECG signal can be sensed between two electrodes on the back of the housing **104** that are in contact with the skin on the user's chest.

The skin temperature sensor **130** can be implemented, e.g., using a thermistor, and can be used to sense the temperature of a user's skin, which can be used to determine user activity and/or calories burned.

Depending upon implementation, heart rate (HR) and heart rate variability (HRV) can be detected based on signals obtained by the optical sensor **122** and/or the ECG sensor **128**. HR and/or HRV can be automatically determined

continuously, periodically or at other specified times or based on a manual user action. For example, in a free living application, HR can be determined automatically during periods of interest, such as when a significant amount of activity is detected.

Additional physiologic metrics can also be obtained using the sensors described herein. For example, respiration rate can be determined from a PPG signal obtained using the optical sensor **122** and/or from the ECG signal determined using the ECG sensor **128**. For another example, blood pressure can be determined from PPG and ECG signals by determining a metric of pulse wave velocity (PWV) and converting the metric of PWV to a metric of blood pressure. More specifically, a metric of PWV can be determined by determining a time from a specific feature (e.g., an R-wave) of an obtained ECG signal to a specific feature (e.g., a maximum upward slope, a maximum peak or a diastolic notch) of a simultaneously obtained PPG signal. An equation can then be used to convert the metric of PWV to a metric of blood pressure.

In accordance with an embodiment the motion sensor **132** is an accelerometer. The accelerometer can be a three-axis accelerometer, which is also known as a three-dimensional (3D) accelerometer, but is not limited thereto. The accelerometer may provide an analog output signal representing acceleration in one or more directions. For example, the accelerometer can provide a measure of acceleration with respect to x, y and z axes. The motion sensor **132** can alternatively be a gyrometer, which provides a measure of angular velocity with respect to x, y and z axes. It is also possible that the motion sensor **132** is an inclinometer, which provides a measure of pitch, roll and yaw that correspond to rotation angles around x, y and z axes. It is also possible the user wearable device **102** includes multiple different types of motion sensors, some examples of which were just described. Depending upon the type(s) of motion sensor(s) used, such a sensor can be used to detect the posture of a portion of a user's body (e.g., a wrist or chest) on which the user-wearable device **102** is being worn.

In the specific embodiments illustrated in FIGS. 1A, 1B and 1C the user-wearable device **102** is intended to be worn on a wrist, and thus, can be referred to as a wrist wearable device **102**. FIG. 1C illustrates a rear-view of the housing or case **104** of the user-wearable device **102** according to a specific embodiment. Referring to FIG. 1C, the back of the housing or case **104**, which can also be referred to as the caseback, is shown as including two electrodes or electrode contacts **134** that are spaced apart from one another, four light emitting devices **136**, a light detecting device **138**, and a metal temperature sensor contact **140**.

In accordance with an embodiment, the light emitting devices **136** and the light detecting device **138** are components of the optical sensor **122** that was discussed above. The optical sensor **122** can alternatively include as few as one light emitting device, two or three light emitting devices, or more than four light emitting device. It is also possible that the optical sensor **122** includes multiple light detecting devices **138**. The light emitting device(s) and light detecting device(s) of the optical sensor **122** are likely covered by light transmissive windows that protect the light emitting device(s) and light detecting device(s).

The two electrodes **134** and **134** can be used for the BIA sensor **120**, the capacitive sensor **124**, the GSR sensor **126** and the/or ECG sensor **128**. For example, switches (not shown) can be used to selectively connect the electrodes **134** to various different electrical circuits within the housing **104** so that they can selectively function as parts of different

types of sensors. More specifically, such switches can selectively connected to the two electrodes **134** to either BIA sensor circuitry, capacitive sensor circuitry, GSR sensor circuitry or ECG sensor circuitry. Where electrode(s) that are used by the BIA sensor **120**, the capacitive sensor **124**, the GSR sensor **126** and the/or ECG sensor **128** are in contact with the user's skin, such sensors are considered to be in contact with the user's skin.

Each of the aforementioned sensors **122**, **124**, **126**, **128**, **130**, **132** can include or have associated analog signal processing circuitry to amplify and/or filter raw signals produced by the sensors. It is also noted that analog signals produced using the aforementioned sensors **122**, **124**, **126**, **128**, **130** and **132** can be converted to digital signals using one or more digital to analog converters (ADCs), as is known in the art. The analog or digital signals produced using these sensors can be subject time domain processing, or can be converted to the frequency domain (e.g., using a Fast Fourier Transform or Discrete Fourier Transform) and subject to frequency domain processing. Such time domain processing, frequency domain conversion and/or frequency domain processing can be performed by a processor (e.g., **204**), or by some other circuitry. FIG. **2** depicts an example block diagram of electrical components of the user-wearable device **102**, according to an embodiment. Referring to FIG. **2**, the user-wearable device **102** is shown as including a microcontroller **202** that includes a processor **204**, memory **206** and a wireless interface **208**. It is also possible that the memory **206** and wireless interface **208**, or portions thereof, are external the microcontroller **202**. The microcontroller **202** is shown as receiving signals from each of the aforementioned sensors **122**, **130** and **132**. The user-wearable device **102** is also shown as including a battery **210** that is used to power the various components of the device **102**. While not specifically shown, the user-wearable device **102** can also include one or more voltage regulators that are used to step-up and or step-down the voltage provided by the battery **210** to appropriate levels to power the various components of the device **102**.

Each of the aforementioned sensors **120**, **122**, **124**, **126**, **128**, **130**, **132** can also include its own circuitry to obtain signals of interest and/or information indicative thereof. For example, the BIA sensor **120** can include circuitry that enables impedance to be measured between a pair of electrodes in contact with a user's skin at one or more frequencies. The optical sensor **122** can include circuitry that selectively drives the light source of the optical sensor **122** and circuitry that amplifies and/or filters a signal produced by the light detector of the optical sensor **122**, and/or converts a current signal produced by the light detector to a voltage signal. The GSR sensor **126** can include circuitry that senses a galvanic skin resistance between a pair of electrode in contact with a user's skin. For another example, the ECG sensor **128** can include circuitry that enables an ECG signal to be sensed between a pair of electrodes in contact with a user's skin. Each of the sensors that requires that one or more electrodes be in contact with a user's skin can include or be coupled to electrodes that are dedicated to the sensor. Alternatively, two or more of the sensors that require one or more electrodes be in contact with a user's skin can share common electrodes, e.g., using switches that selectively connect electrodes to appropriate sensor circuitry in a time divisional multiplexed manner. For a more specific example, there can be a total of two electrodes (e.g., **134**) on the backside of the housing **104** that contact a user's skin when the device **102** is being worn by the user. Where a sensor only requires a single electrode on the backside of the

housing **104**, one of the two electrodes can be used, or the two electrodes can be electrically coupled together to function as a single electrode having a larger surface area than an individual electrode. Additionally, where the battery (e.g., **210**) of the device is a rechargeable battery, the same two electrodes on the backside of the housing **104** can also be selectively used to charge the battery.

The wireless interface **208** can wireless communicate with a base station (e.g., **252**), which as mentioned above, can be a mobile phone, a tablet computer, a PDA, a laptop computer, a desktop computer, or some other computing device that is capable of performing wireless communication. The wireless interface **208**, and more generally the user wearable device **102**, can communicate with a base station **252** using various different protocols and technologies, such as, but not limited to, Bluetooth™, Wi-Fi, ZigBee or ultra-wideband (UWB) communication. In accordance with an embodiment, the wireless interface **208** comprises telemetry circuitry that include a radio frequency (RF) transceiver electrically connected to an antenna (not shown), e.g., by a coaxial cable or other transmission line. Such an RF transceiver can include, e.g., any well-known circuitry for transmitting and receiving RF signals via an antenna to and from an RF transceiver of a base station **252**.

The user-wearable device **102** is shown as including various detectors or trackers, including an on-body detector **212**, a sleep detector **214**, a sleep metric detector **216**, a heart rate (HR) detector **218**, a heart rate variability (HRV) detector **220**, an activity detector **222**, a calorie burn detector **224** and a time and date tracker **226**. The various detectors and trackers may communicate with one another, as will be explained below. Each of these detectors and trackers **212**, **214**, **216**, **218**, **220**, **222**, **224** and **226** can be implemented using software, firmware and/or hardware. It is also possible that some of these detectors and trackers are implemented using software and/or firmware, with others implemented using hardware. Other variations are also possible. In accordance with a specific embodiments, each of these detectors or trackers **212**, **214**, **216**, **218**, **220**, **222**, **224** and **226** is implemented using software code that is stored in the memory **206** and is executed by the processor **204**. The memory **206** is an example of a tangible computer-readable storage apparatus or memory having computer-readable software embodied thereon for programming a processor (e.g., **204**) to perform a method. For example, non-volatile memory can be used. Volatile memory such as a working memory of the processor **204** can also be used. The computer-readable storage apparatus may be non-transitory and exclude a propagating signal.

The on-body detector **212** uses signals and/or data obtained from one or more of the above described sensors to determine whether the user-wearable device **102** is being worn by a user. For example, the on-body detector **212** can use signals/and/or data obtained from the optical sensor **122**, the GSR sensor **126**, the temperature sensor **130** and/or the motion sensor **132** to determine whether the user-wearable device **102** is being worn by a user. Where the user-wearable device has the form factor of a wrist-watch, e.g., as shown in FIGS. **1A** and **1B**, the on-body detector **212** may be referred to as a wrist-off detector or a wrist-on detector. The on-body detector **212** can be used to selective operate the device **102** in a low power mode when the on-body detector **212** detects that the device **102** is not being worn by a user. Additional details of the on-body detector **212** are described in U.S. patent application Ser. No. 14/341,248, titled "User-Wearable Devices with Power Conserving Features," which was filed Jul. 24, 2014.

The sleep detector **214** uses signals and/or data obtained from one or more of the above described sensors to determine whether a user, who is wearing the user-wearable device **102**, is sleeping. For example, signals and/or data obtained using the motion sensor **132** can be used to determine when a user is sleeping. This is because people typically move around less when sleeping compared to when awake. Additionally, if the user's arm posture can be detected from the motion sensor **132**, then information about arm posture can also be used to detect whether or not a user is sleeping. The sleep detector **214** can also be used to detect when a user, who is wearing the user-wearable device **102**, wakes up, as well as when the user is awake.

The sleep metric detector **216** uses signals and/or data obtained from one or more of the above described sensors and/or other detectors and trackers to quantify metrics of sleep, such as total sleep time, sleep efficiency, number of awakenings, and estimates of the length or percentage of time within different sleep states, including, for example, rapid eye movement (REM) and non-REM states. The sleep metric detector **216** can, for example, use signals and/or data obtained from the motion sensor **132** and/or from the HR detector **218** to distinguish between the onset of sleep, non-REM sleep, REM sleep and the user waking from sleep. One or more quality metric of the user's sleep can then be determined based on an amount of time a user spent in the different phases of sleep. Such quality metrics can be displayed on the digital display **108** and/or uploaded to a base station (e.g., **252**) for further analysis.

The HR detector **218** can use signals and/or data obtained from the PPG sensor **122** to detect HR. For example, the optical sensor **222** can be used to obtain a PPG signal from which peak-to-peak intervals can be detected, which can also be referred to as beat-to-beat intervals. The beat-to-beat intervals, which are intervals between heart beats, can be converted to HR using the equation  $HR = (1/\text{beat-to-beat interval}) * 60$ . Thus, if the beat-to-beat interval = 1 sec, then  $HR = 60$  beats per minute (bpm); or if the beat-to-beat interval = 0.6 sec, then  $HR = 100$  bpm. The user's HR can be displayed on the digital display **108** and/or uploaded to a base station (e.g., **252**) for further analysis.

The HRV detector **220** can use signals and/or data obtained from the optical sensor **122** to detect HRV. For example, in the same manner as was explained above, beat-to-beat intervals can be determined from a PPG signal obtained using the PPG sensor **122**. HRV can be determined by calculating a measure of variance, such as, but not limited to, the standard deviation (SD), the root mean square of successive differences (RMSSD), or the standard deviation of successive differences (SDSD) of a plurality of consecutive beat-to-beat intervals. Alternatively, or additionally, an obtained PPG signal can be converted from the time domain to the frequency domain, and HRV can be determined using well known frequency domain techniques. The user's HRV can be displayed on the digital display **108** and/or uploaded to a base station (e.g., **252**) for further analysis.

The activity detector **222** can determine a type and amount of activity of a user based on information such as, but not limited to, motion data obtained using the motion sensor **132**, heart rate as determined by the HR detector **218**, skin temperature as determined by the skin temperature sensor **130**, and time of day. The activity detector **222** can use motion data, obtained using the motion sensor **132**, to determine the number of steps that a user has taken with a specified amount of time (e.g., 24 hours), as well as to determine the distance that a user has walked and/or run within a specified amount of time. Activity metrics can be

displayed on the digital display **108** and/or uploaded to a base station (e.g., **252**) for further analysis.

The calorie burn detector **224** can determine a current calorie burn rate and an amount of calories burned over a specified amount of time based on motion data obtained using the motion sensor **132**, HR as determined using the HR detector **218**, and/or skin temperature as determined using the skin temperature sensor **130**. A calorie burn rate and/or an amount of calories burned can be displayed on the digital display **108** and/or uploaded to a base station (e.g., **252**) for further analysis.

The time and date tracker **226** can keep track of the time of day, date, and/or the like, which are typically tracked by a digital wristwatch. The time and date can be displayed on the digital display **108**. Additionally, the time and date tracker **226** of the user-wearable device can be synced with a similar tracker of the base station **252**. The time and date tracker **226** can provide time of day and date information to the other detectors described herein.

The user-wearable device **102** can include less modules than shown in FIG. 2, more modules than show and/or alternative types of modules. For example, the user-wearable device **102** can also include a body water content module and/or a body fat content module that calculates the user's body water content and/or body fat percentage based on measurements obtained using the BIA sensor **120**. For another example, the user-wearable device **102** can include a stress module that estimates a user's stress level based on measures obtained using the GSR sensor **126**, the ECG sensor **128** and/or the skin temperature sensor **130**. These are just a few examples of other types of modules or detectors that can be included within user-wearable device **102**, which are not intended to be all encompassing.

In accordance with certain embodiments, the optical sensor **122** is implemented as an integrated sensor module, examples of which are described below with reference to FIGS. 4A-6B. In each such embodiment, the optical sensor **122** includes one or more light sources and one or more light detectors. More specifically, in accordance with specific embodiments, the integrated sensor module includes at least one packaged light source semiconductor device (PLSSD) and at least one packaged light detector semiconductor device (PLDSD), which are attached to a substrate and covered by a pre-molded cover structure. In other words, in specific embodiments, each light source is implemented as a PLSSD, and each light detector is implemented as a PLDSD, examples of which are described below with reference to FIGS. 3A and 3B.

FIG. 3A shows a perspective view of an exemplary packaged light source semiconductor device (PLSSD) **312**, and a perspective view of an exemplary packaged light detector semiconductor device (PLDSD) **332**. FIG. 3B shows a bottom view of the exemplary PLSSD **312** shown in FIG. 3A, and a bottom view of the exemplary PLDSD **332** shown in FIG. 3A. Both the PLSSD **312** and the PLDSD **332** can more generically be referred to as packaged optoelectronic semiconductor devices (POSDs).

The PLSSD **312** is shown as including a light source die **314** encapsulated within a light transmissive molding compound **322**. The light source die **314** is shown as including one light emitting element **316**, but can include more than one light emitting element **316**. The light emitting element **316** can be a light emitting diode (LED), an organic LED (OLED), a bulk-emitting LED, a surface-emitting LED, a vertical-cavity surface-emitting laser (VCSEL), a superluminescent light emitting diode (SLED), a laser diode, or a

pixel diode, but is not limited thereto. Light emitting elements, such as those mentioned above, are examples of optoelectronic elements.

The light transmissive molding compound **322** can be, e.g., a light transmissive epoxy (e.g., a clear or tinted epoxy), or other light transmissive resin or polymer. In certain embodiments, the light transmissive molding compound may have a pigment or other property that filters out light of certain wavelengths that are not of interest, while allowing light of wavelengths of interest to pass.

The light source die **314** is connected to electrical contacts **318** (which can alternatively be referred to as electrical connectors) by one or more die pads **315** below the die **314** and/or one or more bond wires **320**. For example, one of the electrical contacts **318** can provide the contact for the anode(s) of the light emitting element(s) **316**, while another one of the electrical contacts **318** can provide the contact for the cathode(s) of the light emitting element(s) **316**. The light source die **314** can also include amplifier circuitry and/or other types of signal processing circuitry.

The PLSSD **312** includes a top surface **324**, a bottom surface **328** and a peripheral surface **326** extending between the top surface **324** and the bottom surface **328**. In this example, the top surface **324** of the PLSSD **312** is formed by a top surface of the light transmissive molding compound **322** (that encapsulates the light emitting element **316**), and the peripheral surface **326** is formed by the four sides of the light transmissive molding compound **322**. The bottom surface **328** includes the electrical contacts **318** for the light emitting element(s) **316**, as best seen in FIG. 3B. The electrical contacts **318** can be, e.g., electrically conductive lands, electrically conductive pads, or electrically conductive balls, but are not limited thereto. For example, it is also possible that the electrical contacts **318** can be electrically conductive pins or wires. In this example, the PLSSD **312** includes two electrical contacts **318** on the bottom surface **328**. In accordance with an embodiment, the PLSSD **312** is a flat no-leads package. In accordance with a specific embodiment, the electrical contacts **318** form a land grid array.

The PLDSD **332** is shown as including a light detector die **334** encapsulated within a light transmissive molding compound **342**. The light detector die **334** is shown as including one light detecting element **336**, but can include more than one light detecting element **336**. The light detecting element **336** can be a photoresistor, a photovoltaic cell, a photodiode, a phototransistor, or a charge-coupled device (CCD), but is not limited thereto, and preferably can be used to produce a current or voltage indicative of the magnitude and/or phase of detected light. Light detecting elements, such as those mentioned above, are also examples of optoelectronic elements.

The light transmissive molding compound **342** can be, e.g., a light transmissive epoxy (e.g., a clear or tinted epoxy), or other light transmissive resin or polymer. In certain embodiments, the light transmissive molding compound may have a pigment or other property that filters out light of certain wavelengths that are not of interest, while allowing light of wavelengths of interest to pass. The light transmissive molding compound **342** of the PLDSD **332** can be the same as, or different than, the light transmissive molding compound **322** of the PLSSD **312**.

The light detector die **334** is electrically connected to electrical contacts **338** (which can alternatively be referred to as electrical connectors) by one or more die pads **335** below the die **334** and/or one or more bond wires **340**. For example, one or more of the electrical contacts **338** can

provide the contact for the anode(s) of the light detecting element(s) **336**, while one or more other electrical contacts **338** can provide the contact for the cathode(s) of the light detecting element(s) **336**. The light detector die **334** can also include amplifier circuitry, filter circuitry and/or other types of signal processing circuitry.

The PLDSD **332** includes a top surface **344**, a bottom surface **348** and a peripheral surface **346** extending between the top surface **344** and the bottom surface **348**. In this example, the top surface **344** of the PLDSD **332** is formed by a top surface of the light transmissive molding compound **342** (that encapsulates the light detecting element **336**), and the peripheral surface **346** is formed by the four sides of the light transmissive molding compound **342**. The bottom surface includes the electrical contacts **338** for the light detecting element(s) **336**, as best seen in FIG. 3B. The electrical contacts **338** can be, e.g., electrically conductive lands, electrically conductive pads, or electrically conductive balls, but are not limited thereto. For example, it is also possible that the electrical contacts **338** can be electrically conductive pins or wires. In this example, the PLDSD **332** includes six electrical contacts **338** and an exposed thermal pad **339** on the bottom surface **348**. The exposed pad **339** can alternatively, or additionally, be a ground plane for the PLDSD **332**. In accordance with an embodiment, the PLDSD **332** is a flat no-leads package. In accordance with a specific embodiment, the electrical contacts **338** form a land grid array.

FIG. 4A is top perspective view of two subassemblies **404**, **406** of an integrated sensor module **402**, according to an embodiment of the present technology, before the two subassemblies **404**, **406** are attached to one another. FIG. 4B is a cross section of the two subassemblies **404**, **406** shown in FIG. 4A. FIG. 4C is a cross section of the two subassemblies **404**, **406** shown in FIGS. 4A and 4B after they have been attached to one another. FIG. 4D is a top view of the integrated sensor module **402** after the two subassemblies **404**, **406** introduced in FIGS. 4A and 4B have been attached to one another.

Referring to FIGS. 4A and 4B, the subassembly **404** includes a substrate **412** having a top surface **414** and a bottom surface **416**. In accordance with an embodiment, the substrate **412** is a printed circuit board (PCB). Alternatively, the substrate **412** can be a ceramic substrate. Other substrate materials are also possible, and within the scope of the embodiments described herein. The PLSSD **312** and the PLDSD **332** are mounted to the top surface **414** of the substrate **412** such that there is a gap between the PLSSD **312** and the PLDSD **332**. As shown in FIG. 4B, the bottom surface **416** of the substrate **412** is shown as including a plurality of electrically conductive balls **418** that collectively form a ball grid array (BGA). Alternatively, the bottom surface **416** of the substrate **412** can include alternative types of electrical contacts in place of the electrically conductive balls **418**, such as, but not limited to, electrically conductive lands, electrically conductive pads, electrically conductive pins or wires.

The subassembly **406** includes a pre-molded cover structure **432** including a portion of which is molded from an opaque molding compound and a further portion of which is molded from a light transmissive molding compound. In other words, the cover structure **432** is co-molded from both an opaque molding compound and a light transmissive molding compound. In FIGS. 4B-4D, the portions of the pre-molded cover structure **432** that are molded from an opaque molding compound are shown as being shaded, and

the portions that are molded from a light transmissive molding compound are not shaded.

The pre-molded cover structure **432** includes a pre-molded cavity **442** covered by a window **444** formed of the light transmissive molding compound. Additionally, the pre-molded cover structure **432** includes further pre-molded cavity **452** covered by a further window **454** formed of the light transmissive molding compound. In an embodiment, the pre-molded cavity **442** has dimensions that are equal to dimensions of the PLSSD **312** plus a tolerance (in each of length, width and height) so that the PLSSD **312** completely fits within the pre-molded cavity **442**. Similarly, the pre-molded cavity **452** has dimensions that are equal to dimensions as the PLDSD **332** plus a tolerance (in each of length, width and height) so that the PLDSD **332** completely fits within the pre-molded cavity **452**. The "tolerance" is a matter of some engineering judgment but is enough to allow the pre-molded cover structure **432** to be readily placed over the PLSSD **312** and the PLDSD **332**. For example, a tolerance of about 1 mm in each of the each of length, width and height is believed appropriate. Larger or smaller tolerances are also possible.

The pre-molded cover structure **432** also includes a barrier **460** formed of the opaque molding compound between the pre-molded cavity **442** and the pre-molded cavity **452**. The opaque molding compound can be, e.g., a black or other dark epoxy, or other resin or polymer that is non-transmissive to the light generated by the PLSSD **312**.

The light transmissive molding compound that is used to form the windows **444** and **454** can be a light transmissive epoxy (e.g., a clear or tinted epoxy) or another light transmissive resin or polymer, but is not limited thereto. In accordance with an embodiment, in order to reduce and preferably minimize specular reflections the light transmissive molding compound that is used to form the window **444** has an index of refraction that is substantially the same as an index of refraction of the light transmissive molding compound that encapsulates the one or more light emitting elements of the light emitter die **314** of the PLSSD **312**. Additionally, the light transmissive molding compound that is used to form the window **454** has an index of refraction that is substantially the same as an index of refraction of the light transmissive molding compound that encapsulates the one or more light detecting elements of the light detector die **334** of the PLDSD **332**. In an embodiment, the same type of light transmission molding compound, having the same index of refraction, is used to encapsulate the light emitting element(s) of the light emitter die **314** of the PLSSD **312**, to encapsulate the light detecting element(s) of the light detector die **334** of the PLDSD **332**, and to form the windows **444** and **454** of the pre-molded cover structure **432**.

As shown in FIG. 4C, the pre-molded cover structure **432** is attached to the substrate **412** such that the PLSSD **312** is positioned within the pre-molded cavity **442**, the PLDSD **332** is positioned within the pre-molded cavity **452**, the barrier **460** is positioned between the PLSSD **312** and the PLDSD **332**, the window covers **444** the one or more light emitting elements of the light emitter die **314** of the PLSSD **312**, and the window **454** covers the one or more light detecting elements of the light detector die **334** of the PLDSD **332**. The barrier **460**, which is formed of the opaque molding compound (and thus, can also be referred to as the opaque barrier **460**) optically isolates the PLSSD **312** and the PLDSD **332** from one another. The opaque molding compound also forms a barrier around the periphery of the integrated sensor module **402**, so as to optically isolate the

module **402** from one or more other optoelectronic modules or apparatus(es) that may be located in the vicinity of the module **402**.

In accordance with an embodiment, a light transmissive adhesive is dispensed between the top surface **324** of the PLSSD **312** and a bottom surface of the window **444**. The light transmissive adhesive helps to attach the subassemblies **404**, **406** to one another. Additionally, the light transmissive adhesive fills in any air gap that may otherwise exist between the top surface **324** of the PLSSD **312** and the bottom surface of the window **444**. In order to reduce and preferably minimize reflections at the interface between the PLSSD **312** and the **444** window, an index of refraction of the light transmissive adhesive is substantially the same as the index of refraction of the light transmissive molding compound that encapsulates the light emitting element(s) of the light emitter die **314** of the PLSSD **312**, and is substantially the same as an index of refraction of the light transmissive molding compound of which the window **444** is formed. Similarly, a light transmissive adhesive is dispensed between the top surface **344** of the PLDSD **332** and a bottom surface of the window **454** to help attach the subassemblies **404**, **406** to one another and to fill in any air gap that may otherwise exist between the top surface **344** of the PLDSD **332** and the bottom surface of the window **454**. In order to reduce and preferably minimize reflections at the interface between the PLDSD **332** and the window **454**, an index of refraction of the light transmissive adhesive is substantially the same as the index of refraction of the light transmissive molding compound that encapsulates the light detecting element(s) of the light detector die **334** of the PLDSD **332**, and is substantially the same as an index of refraction of the light transmissive molding compound of which the window **454** is formed. In accordance with an embodiment, the same type of light transmissive adhesive is dispensed between the top surface **324** of the PLSSD **312** and the bottom surface of the window **444** as is dispensed between the top surface **344** of the PLDSD **332** and the bottom surface of the window **454**. Additionally, to attach the subassemblies **404**, **406**, an adhesive, which can be an opaque adhesive, attaches a bottom surface **462** of the pre-molded cover structure **432** to the top surface **414** of the substrate **412**.

In accordance with an embodiment, a die **422** is embedded within the substrate **402** between the top and bottom surfaces **404**, **406** of the substrate **402**. The embedded die **422** can, e.g., include analog and/or digital circuitry used to drive the one or more light emitting elements of the light emitter die **314** of the PLSSD **312**. Additionally, or alternatively, the die **422** can include analog and/or digital circuitry to perform signal processing on a signal produced by the one or more light detecting elements of the light detector die **334** of the PLDSD **332**. For a more specific example, the analog circuitry can be an analog front end that performs transimpedance amplification, analog signal filtering, and/or analog signal amplification of a signal produced by the one or more light detecting elements of the light detector die **334** of the PLDSD **332**. The die **422** can also include an analog-to-digital converter, digital signal processing circuitry and/or communication interfaces. It is also possible that more than one die is embedded within the substrate **412**. It is also possible that circuitry associate with one or more of the sensors described herein be included within a die that is embedded within the substrate **412**. In addition to (or instead of) the die **422** being embedded within the substrate **412**, one or more discrete circuit components can be embedded with the substrate **412**. Metal vias **424** within the substrate **402** are used to electrically connect the PLSSD **312** and the

PLDSD 332 to the embedded die 422 (and/or discrete circuit components), and to electrically connect the embedded die 422 (and/or discrete circuit components) to the electrically conductive balls 418 or other types of electrical contacts that are on the bottom surface of the substrate 412. Metal vias 424 may also electrically connect the PLSSD 312 and the PLDSD 332 directly to the electrically conductive balls 418 or other types of electrical contacts that are on the bottom surface of the substrate 412. Additionally, there can be electrically conductive traces on the upper surface 414 of the substrate 412, the bottom surface 416 of the substrate 412 and/or within the substrate 412 that provide (alone or in combination with the metal vias 424) for electrical connections between the various electrical components described herein.

FIG. 5 is a cross section of an integrated sensor module 502 that is similar to the module 402 shown in FIGS. 4A-4D, but includes windows having lenses. More specifically, the window 444 is shown as including an integrally formed convex lens 544 which can be used to focus the light emitted by the light emitting element(s) of the light emitter die 314 of the PLSSD 312. Further, the window 454 is shown as including an integrally formed convex lens 554 which can be used to focus light that is incident on the module 502 towards the light detecting element(s) of the light detector die 334 the PLDSD 332. It is also possible that the lenses 544, 554 are separately formed and then attached to the windows 444 and 454. It is also possible that only one of the windows includes a lens, while the other does not. Other shapes for the lens(es) is/are also possible.

In the embodiments described with reference to FIGS. 4A-4D and 5, the sensor modules 402, 502 were described and shown as including one PLSSD 312 and one PLDSD 332. Other variations are possible, and within the scope of embodiments of the present technology, wherein in such other variations one or more PLSSD(s) 312 is/are mounted to a top surface of a substrate, and one or more PLDSD(s) 332 is/are also mounted to the top surface of the substrate, and a pre-molded cover structure including a cavity and window for each of the PLSSD(s) 312 and PLDSD(s) 332. In such embodiments, an opaque barrier of the pre-molded cover structure preferably optically isolates each of the PLSSD(s) 312 and the PLDSD(s) 332 from one another. FIGS. 6A and 6B, described below, provides one example of such an alternative embodiment. However, one of ordinary skill in the art reading this disclosure would understand that other variations are also within the scope of embodiments of the present technology.

FIG. 6A is top perspective view of two subassemblies 604, 606 of an integrated sensor module 602, according to an embodiment of the present technology, before the two subassemblies 604, 606 are attached to one another. FIG. 6B is a top view of the integrated sensor module 602 after the two subassemblies shown in FIG. 6A have been attached to one another. In the embodiment shown in FIGS. 6A and 6B, there is one PLSSD 312 and four PLDSDs 332 that are mounted to the top surface of the substrate 412 such that the PLSSD 312 is positioned in a middle between the four PLDSDs 332, and such that there is a respective gap between the PLSSD 312 and each of the four PLDSDs 332. Here, a pre-molded cover structure 632 includes one cavity 442 for the PLSSD 312, and four cavities 452 for the PLDSDs 332. The cavity 442 is covered by a window 444, and each of the cavities 454 is covered by a respective window 454. Exemplary dimensions of the integrated sensor module 602 are 6 mm×6 mm×1.6 mm, but are not limited thereto. The subassemblies 602, 604 can be attached to one

another in a similar manner as the subassemblies 402, 404 were described above as being attached to one another.

The integrated sensor module 602 can be used to implement certain embodiments described in U.S. patent application Ser. No. 14/341,803, entitled "Sensor System for Heart Rate Measurement Per Axis of Shared Orientation," filed Jul. 26, 2014. For example, the integrated sensor module 602, or a similar integrated sensor module according to an embodiment described herein, can be used in a method for active motion artifact compensation of heart rate data based on measurements taken for at least one axis of orientation shared by light processing elements of a PPG optical sensor and an accelerometer.

An integrated sensor module (e.g., 402, 502 or 602, but not limited thereto) of an embodiment of the present technology can be included in a user-wearable device, such as the wrist worn device described with reference to FIGS. 1A, 1B, 1C and 2. More specifically, an integrated sensor module (e.g., 402, 502 or 602, but not limited thereto) of an embodiment described herein can be used as the optical sensor 122 shown in and described with reference to FIGS. 1B and 2. In accordance with an embodiment, a caseback of the housing 104 includes one or more openings that are intended to be aligned with the windows (e.g., 444, 454) of one of the integrated sensor modules described herein. Alternatively, an integrated sensor module can be used as the caseback. Embodiments of the present technology are also directed to user-wearable devices that include an integrated sensor module described herein. An integrated sensor module (e.g., 402, 502 or 602, but not limited thereto) of an embodiment of the present technology can alternatively be included in other types of devices, such as, but not limited to, a mobile phone, a tablet computer, or a laptop computer.

FIG. 7 is a high level flow diagram of a method for manufacturing an integrated sensor module according to an embodiment of the present technology. Referring to FIG. 7, at step 702, a cover structure (often referred to herein as a pre-molded cover structure) including two more cavities is molded such that a portion thereof is molded from an opaque molding compound and a further portion thereof is molded from a light transmissive molding compound, such that each of the cavities is covered by a respective window formed of the light transmissive molding compound, and such that there is a barrier formed of the opaque molding between each of the cavities. Molding techniques that can be used include, but are not limited to, injection molding, compression molding, transfer molding and cast molding, or combinations thereof. Step 702 can be performed well before (i.e., at a much earlier time than) the remaining steps described below, and may be performed in a different facility than the remaining steps described below. Cavities for one or more additional sensors, such as a packaged temperature sensor semiconductor device, can also be molded or otherwise formed in the cover structure. Additionally, as will be described in additional detail below, with reference to FIGS. 8A and 8B, a thermally conductive metal structure (e.g., 830 in FIG. 8A) can be included in the molded cover structure. Cavities for one or more electrodes can also be molded or otherwise formed in the cover structure. Additionally, as will be described in additional detail below, with reference to FIGS. 8A and 8B, one or more electrically conductive metal structures (e.g., 866a and 866b in FIG. 8A) can be included in the molded cover structure. In certain embodiments, described below with reference to FIGS. 9A and 9B, the cover structure can be co-molded such that one or more electrodes (e.g., 912a and 912b in FIG. 9A) extend from a respective portion of a top surface of the pre-molded cover

structure past a bottom surface of the pre-molded cover structure and thereby extend from the bottom surface of the pre-molded cover structure.

At step 704, one or more packaged light source semiconductor device(s) and one or more packaged light detector semiconductor device(s) are mounted to a top surface of a substrate such that there is a gap between each of the packaged light detector semiconductor device(s) and each of the packaged light source semiconductor device(s). Such mounting can be performed, e.g., using a solder paste. Additionally, or alternatively, a solder reflow process can be performed. Other mounting techniques are also possible. One or more additional sensors, such as a packaged temperature sensor semiconductor device, can also be mounted to the top surface of the substrate.

At step 706, the pre-molded cover structure (molded at step 702) is attached to the top surface of the substrate such that each of the packaged light source semiconductor device(s) and packaged light detector semiconductor device(s), which are mounted to the top surface of the substrate, fits within a respective cavity of the pre-molded cover structure. Step 706 can include dispensing a light transmissive adhesive within each of the cavities and/or dispensing the light transmissive adhesive on a top surface of each of the packaged light source semiconductor device(s) and packaged light detector semiconductor device(s). In specific embodiments, the light transmissive adhesive has an index of refraction that is substantially the same as an index of refraction of the light transmissive molding compound from which the windows are formed. Additionally, the index of refraction of the light transmissive adhesive can also be substantially the same of an index of refraction of a light transmissive molding compound that is used to encapsulate light emitting element(s) and light detecting element(s) of the packaged light source semiconductor device(s) and packaged light detector semiconductor device(s). Step 706 can also include dispensing an opaque adhesive on a top surface of the substrate and/or on a bottom surface of the pre-molded cover structure, to adhere such surfaces to one another.

In accordance with certain embodiments, an integrated sensor module includes one or more sensors and/or electrodes in addition to the optical sensor 122. An example of such an integrated sensor module 802 will now be described with reference to FIGS. 8A and 8B. Referring to FIGS. 8A and 8B, the integrated sensor module 802 is shown as including one PLSSD 312 and four PLDSDs 332 that are mounted to the top surface of the substrate 412 such that the PLSSD 312 is positioned in a middle between the four PLDSDs 332, and such that there is a respective gap between the PLSSD 312 and each of the four PLDSDs 332. The PLSSD 312 and PLDSDs 332 are components of the optical sensor 122. Also mounted to the top surface 414 of the substrate 412 is a packaged temperature sensor semiconductor device (PTSSD) 830, which is an implementation or component of the skin temperature sensor 130 discussed above. Additionally, a pair of electrodes 808a and 808b extend upward from the substrate 412. The electrodes 808a and/or 808b can be connected (e.g., selectively) to sensor circuitry associated with one or more of the sensors described above, such as sensor circuitry associated with the BIA sensor 120, the capacitive sensor 124, the GSR sensor 126 and the/or ECG sensor 128.

Referring to FIG. 8A, in this embodiment, a pre-molded cover structure 832 includes one pre-molded cavity 442 for the PLSSD 312, four pre-molded cavities 452 for the PLDSDs 332, a pre-molded cavity 852 for the PTSSD 830,

and two pre-molded cavities 864a and 864b for the electrodes 808a and 808b. The cavity 442 is covered by a window 444, and each of the cavities 452 is covered by a respective window 454. Located between the cavity 852 (for the PTSSD 830) and a top surface 834 of the pre-molded cover structure 832 is a metal structure 856 (e.g., a block of metal) made of a thermally conductive metal, such as, but not limited to, aluminum or copper. The purpose of the metal structure 856 is to provide a thermal coupling between the PTSSD 830 and the portion of the metal structure 856 that is generally flush with the top surface 834 of the pre-molded cover structure 832 which is intended to come in contact with a user's skin. The sides of the metal structure 856 can be surrounded by and held in place by the opaque molding compound used to form other portions of the pre-molded cover structure 832. In an embodiment, the pre-molded cavity 852 has dimensions that are equal to dimensions of the PTSSD 830 plus a tolerance (in each of length, width and height) so that the PTSSD 830 completely fits within the pre-molded cavity 852. Similarly, the pre-molded cavities 866a and 866b have dimensions that are equal to dimensions as the electrodes 808a and 808b plus a tolerance (in each of length, width and height) so that the electrodes 808a and 808b completely fit within the pre-molded cavities 866a and 866b. The electrodes 808a and 808b can be the same size as one another, or different sizes than one another.

Located between the cavity 864a and the top surface 834 of the pre-molded cover structure 832 is a metal structure 866a (e.g., a cylinder of metal) made of an electrically conductive metal, such as, but not limited to, aluminum or copper. Similarly, located between the cavity 864b and a top surface 834 of the pre-molded cover structure 832 is a metal structure 866b. The purpose of the metal structures 866a and 866b is to provide electrical couplings between the electrodes 808a and 808b and the portions of the metal structures 866a and 866b that are flush with the top surface 834 of the pre-molded cover structure 832 which is intended to come in contact with a user's skin. Explained another way, the metal structures 866a and 866b essentially extend the lengths of the electrodes 808a and 808b. The sides of the metal structures 866a and 866b can be surrounded by and held in place by the opaque molding compound used to form other portions of the pre-molded cover structure 832. In an embodiment, the inner surfaces of the pre-molded cavities 866a and 866b are plated with an electrically conductive metal plating material, such as, but not limited to, copper, aluminum or gold. In such an embodiment, the pre-molded cavities 866a and 866b act as sockets for the electrodes 808a and 808b. In accordance with an embodiment, to upper exposed surfaces of the metal structures 856, 866a and 866b are plated with chromium (also known as chrome) or some other metal or alloy that is resistant to corrosion and/or oxidation.

The subassemblies 802, 804 can be attached to one another in a similar manner as the subassemblies 402, 404 were described above as being attached to one another. In a similar manner discussed above with reference to FIGS. 4A-4D, a light transmissive adhesive can be dispensed between the top surface 324 of the PLSSD 312 and a bottom surface of the window 444 to help to attach the subassemblies 804, 806 to one another and to fill in any air gap that may otherwise exist between the top surface 324 of the PLSSD 312 and the bottom surface of the window 444, wherein an index of refraction of the light transmissive adhesive is preferably substantially the same as the index of refraction of the light transmissive molding compound that encapsulates the light emitting element(s) of the light emitter

die 314 of the PLSSD 312 and the light transmissive molding compound of which the window 444 is formed. In a similar manner discussed above with reference to FIGS. 4A-4D, a light transmissive adhesive can be dispensed between the top surface 344 of the PLDSD 332 and a bottom surface of the window 454 to help attach the subassemblies 804, 806 to one another and to fill in any air gap that may otherwise exist between the top surface 344 of the PLDSD 332 and the bottom surface of the window 454, wherein an index of refraction of the light transmissive adhesive is preferably substantially the same as the index of refraction of the light transmissive molding compound that encapsulates the light detecting element(s) of the light detector die 334 of the PLDSD 332 and the light transmissive molding compound of which the window 454 is formed. Additionally, an adhesive, which can be an opaque adhesive, can be attached to the subassemblies 804, 806, and more specifically, attach a bottom surface 862 of the pre-molded cover structure 832 to the top surface 414 of the substrate 412.

In accordance with an embodiment, an electrically conductive grease or an electrically conductive adhesive is dispensed in the cavities 864a and 864b so that the electrically conductive grease or the electrically conductive adhesive fill in any air gap that may otherwise exist between the top surfaces of the electrodes 812a and 812b and the bottom surfaces of the metal structures 866a and 866b. The electrically conductive grease or adhesive ensures electrical conduction between the electrodes 812a and 812b and the metal structures 866a and 866b. Alternatively, or additionally, electrically conductive springs can be placed within the cavities 864a and 864b. In certain embodiments, the electrodes 812a and 812b and/or the metal structures 866a and 866b are spring loaded to ensure that the electrode 812a and the metal structure 866a contact one another, and to ensure that the electrode 812b and the metal structure 866b contact one another. When the metal structures 866a and 866b are in electrical contact with the electrodes 812a and 812b, the metal structures 866a and 866b become extensions of the electrodes 812a and 812b and can be considered parts of the electrodes 812a and 812b.

In accordance with an embodiment, a thermally conductive grease (also known as a thermal grease) or a thermally conductive adhesive is dispensed in the cavity 852 so that the thermally conductive grease or adhesive fills in any air gap that may otherwise exist between the top surface of the PTSSD 830 and the bottom surface of the metal structure 856. The thermally conductive grease or adhesive ensures thermal conduction between the PTSSD 830 and the metal structure 856. When the metal structure 865 is in thermal contact with the PTSSD 830, the metal structure 856 becomes an extension of the PTSSD 830 and can be considered part of the skin temperature sensor 130.

In FIGS. 8A and 8B the electrodes 812a and 812b and the metal structures 866a and 866b were shown as being cylindrical in shape, but can alternatively have other shapes. Similarly, while the PTSSD 830 and metal structure 856 were shown as having a rectangular cuboid shape, they can alternatively have other shapes.

An integrated sensor module 902 shown in FIGS. 9A and 9B is similar to the integrated sensor module 802 described with reference to FIGS. 8A and 8B, except the integrated sensor module 902 does not include electrodes 812a and 812b extending upward from the substrate 412, and the pre-molded cover structure 832 does not include cavities/sockets 864a and 864b and metal structures 866a and 866b. Rather, a pre-molded cover structure 932 of an upper subassembly 906 includes electrodes 912a and 912b co-molded

therein. The electrodes 912a and 912b are preferably made of an electrically conductive metal, such as, but not limited to, aluminum or copper. In accordance with an embodiment, upper exposed surfaces of the electrodes 912a and 912b are plated with chromium (also known as chrome) or some other metal or alloy that is resistant to corrosion and/or oxidation. The electrodes 912a and 912b extend from a top surface 934 of the pre-molded cover structure 932, all the way through the pre-molded cover structure 932, and extend downward from a bottom surface 962 of the pre-molded cover structure 932. The substrate 412 of a lower subassembly 904 includes openings or through-holes 968a and 968b that are configured to accept the lower or distal portions of the electrodes 912a and 912b that extend downward from the bottom surface 962 of the pre-molded cover structure 932. Inner surfaces of the openings or through-holes 968a and 968b can be plated with an electrically conductive metal plating material, such as, but not limited to, copper, aluminum or gold. The subassemblies 902 and 904 can be attached to one another in a similar manner as the subassemblies 402 and 404 were described above as being attached to one another. Additionally, the lower portions of the electrodes 912a and 912b, which extend downward from the bottom surface 962 of the pre-molded cover structure 932, can be soldered into the openings or through-holes 968a and 968b in the substrate 412. In this manner, soldering of the lower portions of the electrodes 912a and 912b into the openings or through-holes 968a and 968b provides for both electrical connectivity as well as mechanical connectivity between the subassemblies 904 and 906.

In the above described FIGS., the packaged light source semiconductor device(s) and the packaged light detector semiconductor device(s) (e.g., 324, 244) were shown as having rectangular cuboid shapes, and thus, the cavities (e.g., 442, 452) in the pre-molded cover structures (e.g., 432, 632) were also shown as having generally rectangular cuboid shapes. It is also within the scope of embodiments of the present technology that the packaged light detector semiconductor device(s), the packaged light detector semiconductor device(s), and the cavities in the pre-molded cover structures can have alternative shapes, such as, but not limited to, cubic, cylindrical, oval cylindrical, or half-cylindrical. In the FIGS., an outer periphery of the substrate (e.g., 412) and an outer periphery of the pre-molded cover structure (e.g., 432, 642) were shown as being rectangular. It is also within the scope of embodiments of the present technology that an outer periphery of the substrate and an outer periphery of the outer periphery of the pre-molded cover structure can have alternative shapes, such as circular, oval, pentagonal, hexagonal, octagonal, or the like. In accordance with specific embodiments, an outer periphery of the substrate (e.g., 412) and an outer periphery of the pre-molded cover structure (e.g., 432, 642) have the same shape and size so that when they are attached to one another they align with and are flush with one another. In the above described FIGS., each of the windows (e.g., 444, 454) of the pre-molded cover structure was shown as having a rectangular shape. It is also within the scope of embodiments of the present technology that the windows of the pre-molded cover structure can have alternative shapes, such as circular, oval, pentagonal, hexagonal, octagonal, or the like. In the above described FIGS. the windows of the pre-molded cover structure were shown as having a slightly larger footprint than the respective packaged light detector semiconductor device(s) and packaged light detector semiconductor device(s) that the windows cover. It is also within the scope of embodiments of the present technology that the windows can have footprints that

are smaller than the footprints of the respective packaged light detector semiconductor device(s) and packaged light detector semiconductor device(s) that the windows cover. It is also within the scope of embodiments of the present technology that the relative locations of the sensors or portions thereof can be changed. Further, the relative locations of the electrodes included in the integrated sensor modules can be changed.

In the above described embodiments, where a pre-molded cavity (e.g., 442) is covered by a window (e.g., 444), the pre-molded cavity can also be said to have the window, in a similar manner that a room covered by a sky light type of window can be said to have a sky light.

Any one of the integrated sensor modules described herein can be mounted to a printed circuit board (PCB) to which is also mounted other electrical components of a device, such as a processor (e.g., 204), memory (e.g., 206) and wireless interface (208), and/or a microcontroller (e.g., 202). One or more further integrated circuitry chips and/or discrete circuitry can also be mounted to the PCB. Additionally circuitry, such as voltage regulation circuitry, and circuitry to recharge a battery (e.g., 210) can also be mounted to the PCB. Such a PCB, with the integrated sensor module mounted therein, can be included in a user-wearable device or other devices, such as mobile phones and tablet computers, but not limited thereto.

The pre-molded covers structures described herein can also include one or more cavities for additional sensors, which, depending upon the sensor that the cavity is for, may not include any window or metal structure. For example, if a motion sensor is mounted to a surface of the substrate 412, then a pre-molded cover structure can include a cavity within which the motion sensor fits. It would also be possible to include the motion sensor in a die that is embedded in the substrate, or in a device that is mounted to a PCB to which an integrated sensor module is also mounted.

In accordance with certain embodiments, one of the integrated sensor modules described herein can be shaped and otherwise designed to be utilized as the backside or caseback of the housing or case of a user-wearable device, such as the device 104 described above with reference to FIGS. 1A, 1B and 1C. Integrated sensor modules described herein can also be used in other types of user-wearable devices, as well as in other types of devices, such as mobile phones and table computers. Embodiments of the present technology are also directed to user-wearable devices, and other types of devices, that include one of the integrated sensor modules described herein.

The integrated sensor modules described herein can be included in a physiological sensor pod that can be mechanically attachable and removable from user-wearable support structure such as a wrist strap, a head band, a sock, or a shirt, but not limited thereto. An exemplary form factor of a physiologic sensor pod, which can include one of the integrated sensor modules described herein, is shown in FIGS. 10A, 10B and 10C. FIG. 10A is a front perspective view of a physiological sensor pod 1002, which can also be referred to more simply as a sensor pod. FIG. 10B is a bottom view of the sensor pod 1002. FIG. 10C is a side view of the sensor pod 1002. While not specifically shown in FIG. 10A, indicator lights and/or a display can be viewable from the top of the sensor pod 1002. As can be appreciated from FIG. 10B, one of the integrated sensor modules described herein can be used as the back of the sensor pod 1002. FIG. 10C illustrates a groove 1012 extending around a circumference of the sensor pod 1002. Referring to FIG. 11, the

sensor pod 1012 can be placed within an opening 1112 in a wrist band 1102, so that the groove 1012 fits into the opening 1112 and secures the sensor pod in place. The sensor pod 1012 can alternatively be placed in a similar opening in a headband, chest strap, swim cap, arm band, or some other user wearable band or strap. In still other embodiments, the sensor pod 1012 can be placed into a pocket within a sock or tight fitting shirt (e.g., a bicycle shirt) or other article of apparel or clothing that includes a pocket for the sensor pod. Such a pocket can include an opening that enables the backside of the sensor pod, which includes windows for the optical sensor, electrodes or other sensor elements, to contact the wearer's skin to thereby enable the sensor(s) to operate properly. The opening in the pocket can also enable the groove 1012 in the sensor pod 1002 to be snapped into a correct position and held in place against a user's skin. The sensor pod 1012 can alternatively be placed in an opening, slot and/or pocket in a helmet (e.g., a bicycle, motorcycle, skateboard, football, baseball, hockey, snowboard or ski helmet) or other headwear (e.g., a beanie, a baseball cap or any other type of hat). The sensor pod can include a wireless interface that enables it to communicate with and sync with a bases station, such as a mobile phone, tablet computer, laptop computer, or the like. Exemplary electrical components and modules that can be included within a sensor pod are shown in and described above with reference to FIG. 2. In certain embodiments, the sensor pods are water tight so that they can get wet and still operate.

The foregoing detailed description of the technology herein has been presented for purposes of illustration and description. It is not intended to be exhaustive or to limit the technology to the precise form disclosed. Many modifications and variations are possible in light of the above teaching. The described embodiments were chosen to best explain the principles of the technology and its practical application to thereby enable others skilled in the art to best utilize the technology in various embodiments and with various modifications as are suited to the particular use contemplated. It is intended that the scope of the technology be defined by the claims appended hereto. While various embodiments have been described above, it should be understood that they have been presented by way of example, and not limitation. It will be apparent to persons skilled in the relevant art that various changes in form and detail can be made therein without departing from the spirit and scope of the invention. The breadth and scope of the present technology should not be limited by any of the above-described exemplary embodiments, but should be defined only in accordance with the following claims and their equivalents.

What is claimed is:

1. A sensor module, comprising:

- a substrate having a top surface and a bottom surface;
- a packaged light source semiconductor device mounted to the top surface of the substrate, the packaged light source semiconductor device including
  - a light emitter die including one or more light emitting elements encapsulated by a light transmissive molding compound;
  - a top surface formed by a top surface of the light transmissive molding compound that encapsulates the one or more light emitting elements;
  - a bottom surface including electrical contacts for the one or more light emitting elements; and
  - a peripheral surface extending between the top and bottom surfaces;
- a packaged light detector semiconductor device mounted to the top surface of the substrate such that there is a

gap between the packaged light detector semiconductor device and the packaged light source semiconductor device, the packaged light detector semiconductor device including

a light detector die including one or more light detecting elements encapsulated by a light transmissive molding compound;

a top surface formed by a top surface of the light transmissive molding compound that encapsulates the one or more light detecting elements;

a bottom surface including electrical contacts for the one or more light detecting elements; and

a peripheral surface extending between the top and bottom surfaces; and

a pre-molded cover structure including a portion of which is molded from an opaque molding compound and also including

a first pre-molded cavity covered by a first light transmissive window;

a second pre-molded cavity covered by a second light transmissive window; and

a barrier formed of the opaque molding compound between the first pre-molded cavity and the second pre-molded cavity;

wherein the pre-molded cover structure is attached to the substrate such that the packaged light source semiconductor device is positioned within the first pre-molded cavity, the packaged light detector semiconductor device is positioned within the second pre-molded cavity, the barrier is positioned between the packaged light detector semiconductor device and the packaged light source semiconductor device, the first light transmissive window covers the one or more light emitting elements of the light emitter die, and the second light transmissive window covers the one or more light detecting elements of the light detector die;

wherein the light transmissive molding compound, which encapsulates the one or more light emitting elements of the light emitter die of the packaged light source semiconductor device, has an index of refraction that is substantially the same as an index of refraction of the first light transmissive window, which covers the first pre-molded cavity of the pre-molded cover structure in which the packaged light source semiconductor device is positioned; and

wherein the light transmissive molding compound, which encapsulates the one or more light detecting elements of the light detector die of the packaged light detector semiconductor device, has an index of refraction that is substantially the same as an index of refraction of the second light transmissive window, which covers the second pre-molded cavity of the pre-molded cover structure in which the packaged light detector semiconductor device is positioned.

2. The sensor module of claim 1, wherein:

the first pre-molded cavity has dimensions that are equal to dimensions of the packaged light source semiconductor device plus a tolerance so that the packaged light source semiconductor device completely fits within the first pre-molded cavity; and

the second pre-molded cavity has dimensions that are equal to dimensions as the packaged light detector semiconductor device plus a tolerance so that the packaged light detector semiconductor device fits within the second pre-molded cavity.

3. The sensor module of claim 1, further comprising:

a further die embedded within the substrate, between the top and bottom surfaces of the substrate, the further die including circuitry used to drive the one or more light emitting elements of the light emitter die and/or perform signal processing on a signal produced by the one or more light detecting elements of the light detector die.

4. The sensor module of claim 1, further comprising:

a light transmissive adhesive between the top surface of the packaged light source semiconductor device and the first window, the light transmissive adhesive having an index of refraction that is substantially the same as the index of refraction of the light transmissive molding compound that encapsulates the one or more light emitting elements of the light emitter die and that is substantially the same as an index of refraction of the light transmissive molding compound of which the first window is formed.

5. The sensor module of claim 1, wherein the electrical contacts on the bottom surface of each of the dies are selected from the group consisting of:

electrically conductive lands;

electrically conductive pads;

electrically conductive balls;

electrically conductive pins; and

electrically conductive wires.

6. The sensor module of claim 1, further comprising:

one or more additional packaged light detector semiconductor devices mounted to the top surface of the substrate, such that there is a plurality of packaged light detector semiconductor devices mounted to the top surface of the substrate;

wherein the plurality of packaged light detector semiconductor devices and the packaged light source semiconductor device are mounted to the top surface of the substrate such that the packaged light source semiconductor device is positioned in a middle between the plurality of packaged light detector semiconductor devices and such that there is a respective gap between the light source semiconductor device and each of the plurality of packaged light detector semiconductor devices;

wherein the pre-molded cover structure includes one or more additional cavities, each of which is covered by a respective additional window formed of the light transmissive molding compound;

wherein with the pre-molded cover structure attached to the substrate, each of the one or more additional packaged light detector semiconductor devices is positioned within a respective one of the one or more additional cavities in the pre-molded cover structure, and the barrier formed of the opaque molding compound is also positioned between the packaged light detector semiconductor device and the one or more additional packaged light detector semiconductor devices.

7. The sensor module of claim 1, wherein a bottom surface of the substrate includes electrical contacts that enable the sensor module to be electrically connected to further circuitry.

8. The sensor module of claim 1, further comprising a lens that is integrally formed with or attached to one of the first and second windows.

9. The sensor module of claim 1, further comprising:

a packaged temperature sensor semiconductor device mounted to a top surface of the substrate;

25

- a pre-molded temperature sensor cavity within the pre-molded cover structure having dimensions that are equal to dimensions of the packaged temperature sensor semiconductor device plus a tolerance so that the packaged temperature sensor semiconductor device completely fits within the pre-molded temperature sensor cavity; and
- a metal structure within the pre-molded cover structure that extends between the a top surface of the pre-molded cover structure and a top of the temperature sensor cavity;
- wherein the metal structure is made of a thermally conductive metal and provides a thermal coupling between the packaged temperature sensor semiconductor device and a portion of the top surface of the pre-molded cover structure.
10. The sensor module of claim 9, further comprising:  
a thermally conductive grease or a thermally conductive adhesive between a top surface of the temperature sensor semiconductor device and a bottom surface of the metal structure.
11. The sensor module of claim 9, further comprising:  
one or more electrodes extending upward from a top surface of the substrate;  
one or more electrode cavities with the pre-molded cover structure, wherein inner surfaces of the pre-molded cavities are coated with an electrically conductive metal;  
one or more metal structures within the pre-molded cover structure each of which extends between the a top surface of the pre-molded cover structure and a top of one of one or more the electrode cavities;  
wherein each of the one or more metal structures is made of an electrically conductive metal and provides an electrical coupling between one of the one or more electrodes extending upward from the top surface of the substrate and a respective portion of the top surface of the pre-molded cover structure.
12. The sensor module of claim 11, further comprising:  
an electrically conductive grease or an electrically conductive adhesive between a top surface of each of the one or more electrodes and a bottom surface of a respective said metal structure.
13. The sensor module of claim 1, further comprising:  
one or more electrodes extending downward from a respective portion of a top surface of the pre-molded cover structure past a bottom surface of the pre-molded cover structure such that a portion of each of the one or more electrodes extend downward from the bottom surface of the pre-molded cover structure;  
one or more openings or through holes in the substrate that are configured to receive the portion of the one or more electrodes that extend downward from the bottom surface of the pre-molded cover structure.
14. A user-wearable device, comprising:  
a housing having a front side and a back side;  
a band that straps the housing to a person's wrist;  
a digital display on the front side of the housing; and  
a sensor module on the back side of the housing;  
wherein the sensor module comprises  
a substrate having a top surface and a bottom surface;  
a packaged light source semiconductor device mounted to the top surface of the substrate, the packaged light source semiconductor device including  
a light emitter die including one or more light emitting elements encapsulated by a light transmissive molding compound;

26

- a top surface formed by a top surface of the light transmissive molding compound that encapsulates the one or more light emitting elements;  
a bottom surface including electrical contacts for the one or more light emitting elements; and  
a peripheral surface extending between the top and bottom surfaces;
- a packaged light detector semiconductor device mounted to the top surface of the substrate such that there is a gap between the packaged light detector semiconductor device and the packaged light source semiconductor device, the packaged light detector semiconductor device including  
a light detector die including one or more light detecting elements encapsulated by a light transmissive molding compound;  
a top surface formed by a top surface of the light transmissive molding compound that encapsulates the one or more light detecting elements;  
a bottom surface including electrical contacts for the one or more light detecting elements; and  
a peripheral surface extending between the top and bottom surfaces;
- a pre-molded cover structure including a portion of which is molded from an opaque molding compound and also including  
a first pre-molded cavity covered by a first light transmissive window;  
a second pre-molded cavity covered by a second light transmissive window; and  
a barrier formed of the opaque molding compound between the first pre-molded cavity and the second pre-molded cavity;
- wherein the pre-molded cover structure is attached to the substrate such that the packaged light source semiconductor device is positioned within the first pre-molded cavity, the packaged light detector semiconductor device is positioned within the second pre-molded cavity, the barrier is positioned between the packaged light detector semiconductor device and the packaged light source semiconductor device, the first light transmissive window covers the one or more light emitting elements of the light emitter die, and the second light transmissive window covers the one or more light detecting elements of the light detector die;
- wherein the light transmissive molding compound, which encapsulates the one or more light emitting elements of the light emitter die of the packaged light source semiconductor device, has an index of refraction that is substantially the same as an index of refraction of the first light transmissive window, which covers the first pre-molded cavity of the pre-molded cover structure in which the packaged light source semiconductor device is positioned; and  
wherein the light transmissive molding compound, which encapsulates the one or more light detecting elements of the light detector die of the packaged light detector semiconductor device, has an index of refraction that is substantially the same as an index of refraction of the second light transmissive window, which covers the second pre-molded cavity of the pre-molded cover structure in which the packaged light detector semiconductor device is positioned.
15. The user-wearable device of claim 14, wherein the sensor module also includes a further die embedded within

27

the substrate, between the top and bottom surfaces of the substrate, the further die including circuitry used to drive the one or more light emitting elements of the light emitter die and/or perform signal processing on a signal produced by the one or more light detecting elements of the light detector die.

16. The user-wearable device of claim 14, further comprising:

a light transmissive adhesive between the top surface of the packaged light source semiconductor device and the first window, the light transmissive adhesive having an index of refraction that is substantially the same as the index of refraction of the light transmissive molding compound that encapsulates the one or more light emitting elements of the light emitter die and that is substantially the same as an index of refraction of the light transmissive molding compound of which the first window is formed; and

a light transmissive adhesive between the top surface of the packaged light detector semiconductor device and the second window, the light transmissive adhesive having an index of refraction that is substantially the same as the index of refraction of the light transmissive molding compound that encapsulates the one or more light detecting elements of the light detector die and that is substantially the same as an index of refraction of the light transmissive molding compound of which the second window is formed.

17. The user-wearable device of claim 14, wherein the sensor module also includes

a packaged temperature sensor semiconductor device mounted to a top surface of the substrate;

a metal structure within the pre-molded cover structure that extends between the a top surface of the pre-molded cover structure and a top of the temperature sensor cavity;

28

wherein the metal structure is made of a thermally conductive metal and provides a thermal coupling between the packaged temperature sensor semiconductor device and a portion of the top surface of the pre-molded cover structure.

18. The user-wearable device of claim 14, wherein the sensor module also includes:

one or more electrodes extending upward from a top surface of the substrate;

one or more electrode cavities with the pre-molded cover structure, wherein inner surfaces of the electrode cavities are coated with an electrically conductive metal; one or more metal structures within the pre-molded cover structure each of which extends between a top surface of the pre-molded cover structure and a top of one of one or more the electrode cavities;

wherein each of the one or more metal structures is made of an electrically conductive metal and provides an electrical coupling between one of the one or more electrodes extending upward from the top surface of the substrate and a respective portion of the top surface of the pre-molded cover structure.

19. The user-wearable device of claim 14, wherein the sensor module also includes:

one or more electrodes extending downward from a respective portion of a top surface of the pre-molded cover structure past a bottom surface of the pre-molded cover structure such that a portion of each of the one or more electrodes extend downward from the bottom surface of the pre-molded cover structure;

one or more openings or through holes in the substrate that are configured to receive the portion of the one or more electrodes that extend downward from the bottom surface of the pre-molded cover structure.

\* \* \* \* \*

专利名称(译)	集成传感器模块		
公开(公告)号	<a href="#">US10165954</a>	公开(公告)日	2019-01-01
申请号	US14/661819	申请日	2015-03-18
申请(专利权)人(译)	SALUTRON INC.		
当前申请(专利权)人(译)	salutron Inc.		
[标]发明人	LEE YONG JIN		
发明人	LEE, YONG JIN		
IPC分类号	A61B5/024 H01L25/16 A61B5/00 A61B5/053 A61B5/0205 A61B5/0245		
CPC分类号	A61B5/02427 A61B5/0205 A61B5/02416 A61B5/0537 A61B5/681 H01L25/167 H01L2224/73265 A61B5/0245 A61B5/0531 H01L2924/00012 H01L2224/32245 H01L2224/48247 H01L2224/48091		
优先权	62/031813 2014-07-31 US 62/058492 2014-10-01 US		
其他公开文献	US20160029911A1		
外部链接	<a href="#">Espacenet</a>		

摘要(译)

集成传感器模块包括一个或多个封装的光源半导体器件和安装到衬底顶面的一个或多个封装的光检测器半导体器件。预模制的盖结构包括由不透明模塑料模制的部分和由透光模塑料模制的另一部分。对于每个封装的光源和光检测器半导体器件，预模制的盖结构包括由透光模塑料形成的窗口覆盖的预模制腔。预模制的盖结构附接到基板，使得每个封装的光源和光检测器半导体器件装配在相应的腔内，并且使得由不透明的模塑料形成的阻挡层位于每个封装的光源半导体器件之间。和光检测器半导体器件。该模块还可以包括供传感器使用的附加传感器和/或电极。

