



(56)

## References Cited

## U.S. PATENT DOCUMENTS

3,215,136	A	11/1965	Holter et al.	6,775,566	B2	8/2004	Nissila
3,547,107	A	12/1970	Chapman et al.	6,801,137	B2	10/2004	Eggers
3,870,034	A	3/1975	James	6,801,802	B2	10/2004	Sitzman et al.
4,027,664	A	6/1977	Heavner, Jr. et al.	6,881,191	B2	4/2005	Oakley et al.
4,121,573	A	10/1978	Crovella et al.	6,893,396	B2	5/2005	Schulze et al.
4,123,785	A	10/1978	Cherry et al.	6,940,403	B2	9/2005	Kail
4,202,139	A	5/1980	Hong et al.	6,954,163	B2	10/2005	Toumazou et al.
4,274,419	A	6/1981	Tam et al.	6,957,107	B2	10/2005	Rogers et al.
4,274,420	A	6/1981	Hymes	7,002,468	B2	2/2006	Eveland et al.
4,333,475	A	6/1982	Moreno et al.	7,020,508	B2	3/2006	Stivoric et al.
4,459,987	A	7/1984	Pangburn	7,024,248	B2	4/2006	Penner et al.
4,535,783	A	8/1985	Marangoni	7,072,708	B1	7/2006	Andresen et al.
4,572,187	A	2/1986	Schettrumpf	7,072,709	B2	7/2006	Xue
4,712,552	A	12/1987	Pangburn	7,076,283	B2	7/2006	Cho et al.
4,736,752	A	4/1988	Munck et al.	7,076,287	B2	7/2006	Rowlandson
4,925,453	A	5/1990	Kannankeril	7,076,288	B2	7/2006	Skinner
4,981,141	A	1/1991	Segalowitz	7,076,289	B2	7/2006	Sarkar et al.
5,003,987	A	4/1991	Grinwald	7,079,977	B2	7/2006	Osorio et al.
5,027,824	A	7/1991	Dougherty et al.	7,082,327	B2	7/2006	Houben
5,086,778	A	2/1992	Mueller et al.	7,099,715	B2	8/2006	Korzinov et al.
5,205,295	A	4/1993	Del Mar et al.	7,130,396	B2	10/2006	Rogers et al.
5,228,450	A	7/1993	Sellers	7,179,152	B1	2/2007	Rhoades
5,230,119	A	7/1993	Woods et al.	7,193,264	B2	3/2007	Lande
5,289,824	A	3/1994	Mills et al.	7,194,300	B2	3/2007	Korzinov
5,365,935	A	11/1994	Righter et al.	7,206,630	B1	4/2007	Tarler
5,483,967	A	1/1996	Ohtake	7,212,850	B2	5/2007	Prystowsky et al.
5,489,624	A	2/1996	Kantner et al.	7,242,318	B2	7/2007	Harris
5,511,553	A	4/1996	Segalowitz	7,266,361	B2	9/2007	Burdett
5,515,858	A	5/1996	Myllymaki	7,316,671	B2	1/2008	Lastovich et al.
5,536,768	A	7/1996	Kantner et al.	7,354,423	B2	4/2008	Zelickson et al.
5,626,140	A	5/1997	Feldman et al.	7,387,607	B2	6/2008	Holt et al.
5,634,468	A	6/1997	Platt et al.	7,481,772	B2	1/2009	Banet
5,645,068	A	7/1997	Mezack et al.	7,482,314	B2	1/2009	Grimes et al.
5,730,143	A	3/1998	Schwarzberg	7,502,643	B2	3/2009	Farrington et al.
5,749,365	A	5/1998	Magill	7,587,237	B2	9/2009	Korzinov et al.
5,749,367	A	5/1998	Gamlyn et al.	7,630,756	B2	12/2009	Linker
5,771,524	A	6/1998	Woods et al.	7,632,174	B2	12/2009	Gringer et al.
5,881,743	A	3/1999	Nadel	7,729,753	B2	6/2010	Kremliovskiy et al.
5,957,854	A	9/1999	Besson et al.	D621,048	S	8/2010	Severe et al.
5,959,529	A	9/1999	Kail	7,815,494	B2	10/2010	Gringer et al.
6,013,007	A	1/2000	Root et al.	7,841,039	B1	11/2010	Squire
6,044,515	A	4/2000	Zygmunt	7,889,070	B2	2/2011	Reeves et al.
6,093,146	A	7/2000	Filangeri	D634,431	S	3/2011	Severe et al.
D429,336	S	8/2000	Francis et al.	7,907,996	B2	3/2011	Prystowsky et al.
6,102,856	A	8/2000	Groff et al.	7,941,207	B2	5/2011	Korzinov
6,117,077	A	9/2000	Del Mar et al.	7,996,075	B2	8/2011	Korzinov et al.
6,134,480	A	10/2000	Minogue	8,002,701	B2	8/2011	John et al.
6,136,008	A	10/2000	Becker et al.	8,077,042	B2	12/2011	Peeters
6,161,036	A	12/2000	Matsumura et al.	8,116,841	B2	2/2012	Bly et al.
6,169,915	B1	1/2001	Krumbiegel et al.	8,150,502	B2	4/2012	Kumar et al.
6,178,357	B1	1/2001	Gliner et al.	8,160,682	B2	4/2012	Kumar et al.
6,200,265	B1	3/2001	Walsh et al.	D659,836	S	5/2012	Bensch et al.
6,225,901	B1	5/2001	Kail	8,200,319	B2	6/2012	Pu et al.
6,232,366	B1	5/2001	Wang et al.	8,214,007	B2	7/2012	Baker et al.
6,238,338	B1	5/2001	DeLuca et al.	8,244,335	B2	8/2012	Kumar et al.
6,290,707	B1	9/2001	Street	8,249,686	B2	8/2012	Libbus et al.
6,385,473	B1	5/2002	Haines et al.	RE43,767	E	10/2012	Eggers et al.
6,416,471	B1	7/2002	Kumar et al.	8,285,356	B2	10/2012	Bly et al.
6,454,708	B1	9/2002	Ferguson et al.	8,290,129	B2	10/2012	Rogers et al.
6,456,872	B1	9/2002	Faisandier	8,326,407	B2	12/2012	Linker
6,464,815	B1	10/2002	Beaudry	8,374,688	B2	2/2013	Libbus et al.
6,493,898	B1	12/2002	Woods et al.	8,406,843	B2	3/2013	Tiegis et al.
6,510,339	B2	1/2003	Kovtun et al.	8,412,317	B2	4/2013	Mazar
6,546,285	B1	4/2003	Owen et al.	8,425,414	B2	4/2013	Eveland
6,569,095	B2	5/2003	Eggers	8,452,356	B2	5/2013	Vestel et al.
6,580,942	B1	6/2003	Willshire	8,460,189	B2	6/2013	Libbus et al.
6,585,707	B2	7/2003	Cabiri et al.	8,473,047	B2	6/2013	Chakravarthy et al.
6,589,187	B1	7/2003	Dirnberger et al.	8,515,529	B2	8/2013	Pu et al.
6,605,046	B1	8/2003	Del Mar	8,538,503	B2*	9/2013	Kumar et al. .... 600/391
6,664,893	B1	12/2003	Eveland et al.	8,560,046	B2*	10/2013	Kumar et al. .... 600/392
6,665,385	B2	12/2003	Rogers et al.	8,591,430	B2	11/2013	Amurthur et al.
6,690,959	B2	2/2004	Thompson	8,684,925	B2	4/2014	Amurthur et al.
6,694,177	B2	2/2004	Eggers et al.	8,688,190	B2	4/2014	Libbus et al.
6,701,184	B2	3/2004	Henkin	8,718,752	B2	5/2014	Libbus et al.
6,711,427	B1	3/2004	Ketelhohn	8,790,257	B2	7/2014	Libbus et al.
				8,795,174	B2	8/2014	Manicka et al.
				8,818,481	B2	8/2014	Bly et al.
				8,823,490	B2	9/2014	Libbus et al.
				9,017,256	B2*	4/2015	Gottesman ..... A61B 5/486

(56)

## References Cited

## U.S. PATENT DOCUMENTS

			600/300
2001/0056262	A1*	12/2001	Cabiri et al. .... 604/180
2002/0067256	A1	6/2002	Kail
2002/0082491	A1	6/2002	Nissila
2003/0069510	A1	4/2003	Semler et al.
2003/0083559	A1	5/2003	Thompson
2003/0149349	A1	8/2003	Jensen
2003/0176795	A1	9/2003	Harris et al.
2004/0032957	A1	2/2004	Mansy et al.
2004/0077954	A1	4/2004	Oakley et al.
2004/0215091	A1	10/2004	Lohman et al.
2004/0260189	A1	12/2004	Eggers et al.
2005/0096513	A1*	5/2005	Ozguz ..... H01L 21/6836 600/301
2005/0101875	A1	5/2005	Semler et al.
2005/0118246	A1	6/2005	Wong et al.
2005/0119580	A1	6/2005	Eveland
2005/0165323	A1	7/2005	Montgomery et al.
2005/0277841	A1	12/2005	Shennib
2006/0030781	A1	2/2006	Shennib
2006/0030782	A1	2/2006	Shennib
2006/0047215	A1	3/2006	Newman et al.
2006/0084883	A1	4/2006	Linker
2006/0142648	A1	6/2006	Banet et al.
2006/0142654	A1	6/2006	Rytky
2006/0149156	A1	7/2006	Cochran et al.
2006/0155173	A1	7/2006	Anttila et al.
2006/0155183	A1	7/2006	Kroecker et al.
2006/0155199	A1	7/2006	Logier et al.
2006/0155200	A1	7/2006	Ng et al.
2006/0161064	A1	7/2006	Watrous et al.
2006/0161065	A1	7/2006	Elion
2006/0161066	A1	7/2006	Elion
2006/0161067	A1	7/2006	Elion
2006/0161068	A1	7/2006	Hastings et al.
2006/0224072	A1	10/2006	Shennib
2006/0264767	A1	11/2006	Shennib
2007/0003695	A1	1/2007	Tregub et al.
2007/0088419	A1*	4/2007	Fiorina et al. .... 607/152
2007/0156054	A1	7/2007	Korzinov et al.
2007/0225611	A1	9/2007	Kumar et al.
2007/0249946	A1	10/2007	Kumar et al.
2007/0255153	A1	11/2007	Kumar et al.
2007/0270678	A1	11/2007	Fadem et al.
2007/0293776	A1	12/2007	Korzinov et al.
2008/0039730	A1	2/2008	Pu et al.
2008/0091089	A1	4/2008	Guillory et al.
2008/0108890	A1	5/2008	Teng et al.
2008/0114232	A1*	5/2008	Gazit ..... A61B 5/6831 600/390
2008/0139953	A1	6/2008	Baker et al.
2008/0275327	A1	11/2008	Faarbaek et al.
2008/0288026	A1	11/2008	Cross et al.
2009/0073991	A1	3/2009	Landrum et al.
2009/0076336	A1	3/2009	Mazar et al.
2009/0076340	A1	3/2009	Libbus et al.
2009/0076341	A1	3/2009	James et al.
2009/0076342	A1	3/2009	Amurthur et al.
2009/0076343	A1	3/2009	James et al.
2009/0076344	A1	3/2009	Libbus et al.
2009/0076345	A1	3/2009	Manicka et al.
2009/0076346	A1	3/2009	James et al.
2009/0076349	A1	3/2009	Libbus et al.
2009/0076350	A1	3/2009	Bly et al.
2009/0076397	A1	3/2009	Libbus et al.
2009/0076401	A1	3/2009	Mazar et al.
2009/0076559	A1	3/2009	Libbus et al.
2009/0182204	A1*	7/2009	Semler ..... A61B 5/04085 600/301
2009/0292194	A1	11/2009	Libbus et al.
2010/0056881	A1	3/2010	Libbus et al.
2010/0081913	A1	4/2010	Cross et al.
2010/0145359	A1	6/2010	Keller
2010/0191310	A1	7/2010	Bly
2010/0234716	A1	9/2010	Engel

2010/0249625	A1	9/2010	Lin
2010/0268103	A1	10/2010	McNamara et al.
2011/0087083	A1	4/2011	Poeze et al.
2011/0144470	A1	6/2011	Mazar et al.
2011/0166468	A1	7/2011	Prystowsky et al.
2012/0071730	A1	3/2012	Romero
2012/0071731	A1	3/2012	Gottesman
2012/0083670	A1	4/2012	Rotondo et al.
2012/0108917	A1	5/2012	Libbus et al.
2012/0108920	A1	5/2012	Bly et al.
2012/0110226	A1	5/2012	Vlach et al.
2012/0110228	A1	5/2012	Vlach et al.
2012/0172676	A1	7/2012	Penders et al.
2012/0310070	A1	12/2012	Kumar et al.
2013/0046151	A1	2/2013	Bsoul et al.
2013/0085347	A1	4/2013	Manicka et al.
2013/0096395	A1	4/2013	Katra et al.
2013/0116585	A1	5/2013	Bouguerra
2013/0225938	A1	8/2013	Vlach
2013/0226018	A1	8/2013	Kumar et al.
2013/0253285	A1	9/2013	Bly et al.
2013/0274584	A1	10/2013	Brion et al.
2013/0331665	A1	12/2013	Bly et al.
2013/0338448	A1	12/2013	Libbus et al.
2014/0012154	A1	1/2014	Mazar

## FOREIGN PATENT DOCUMENTS

JP	08-317913	A	3/1996
JP	2000-126145		5/2000
JP	2007-296266		11/2007
JP	2009-525816	A	7/2009
WO	WO 99/23943	A1	5/1999
WO	WO 01/16607	A2	3/2001
WO	WO 2005/037946	A1	4/2005
WO	WO 2005/084533	A1	9/2005
WO	WO 2006/094513		9/2006
WO	WO 2007/049080	A1	3/2007
WO	WO 2007/036748	A2	4/2007
WO	WO 2007/063436		6/2007
WO	WO 2007/072069	A2	6/2007
WO	WO 2008/057884		5/2008
WO	WO 2011/077097		6/2011
WO	WO 2012/009453		1/2012

## OTHER PUBLICATIONS

European Office Action dated Aug. 29, 2014 for European Patent Application No. 11781310.5.

3M Corporation, "3M Surgical Tapes—Choose the Correct Tape" quicksheet (2004).

Del Mar et al.; The history of clinical holter monitoring; A.N.E.; vol. 10; No. 2; pp. 226-230; Apr. 2005.

Enseleit et al.; Long-term continuous external electrocardiographic recording: a review; Eurospace; vol. 8; pp. 255-266; 2006.

Hoefman et al.; Optimal duration of event recording for diagnosis of arrhythmias in patients with palpitations and light-headedness in the general practice; Family Practice; Dec. 7, 2006.

Kennedy et al.; The history, science, and innovation of holter technology; A.N.E.; vol. 11; No. 1; pp. 85-84; 2006.

Reiffel et al.; Comparison of autotriggered memory loop recorders versus standard loop recorders versus 24-hour holer monitors for arrhythmia detection; Am. J. Cardiology; vol. 95; pp. 1055-1059; May 1, 2005.

Scapa Medical product listing and descriptions (2008) available at <http://www.caapana.com/productlist.jsp> and <http://www.metplus.co.rs/pdf/prospekti/Samolepljivemedicinsketrake.pdf>; retrieved via WayBack Machine Sep. 24, 2012.

Ward et al.; Assessment of the diagnostic value of 24-hour ambulatory electrocardiographic monitoring; Biotelemetry Patient monitoring; vol. 7; 1980.

Ziegler et al.; Comparison of continuous versus intermittent monitoring of atrial arrhythmias; Heart Rhythm; vol. 3; No. 12; pp. 1445-1452; Dec. 2006.

Zimetbaum et al.; The evolving role of ambulatory arrhythmia monitoring in general clinic practice; Ann. Intern. Med.; vol. 130; pp. 848-8556; 1999.

(56)

**References Cited**

OTHER PUBLICATIONS

Zimetbaum et al.; Utility of patient-activated cardiac event recorders in general clinical practice; The Amer. J. of Cardiology; vol. 79; Feb. 1, 1997.

Request for Reexamination of U.S. Pat. No. 7,020,508 under 35 U.S.C. §§ 311-318 and 37 C.F.R. § 1.913 as submitted Sep. 14, 2012 in 78 pages.

US 8,750,980, 06/2014, Katra et al. (withdrawn)

\* cited by examiner

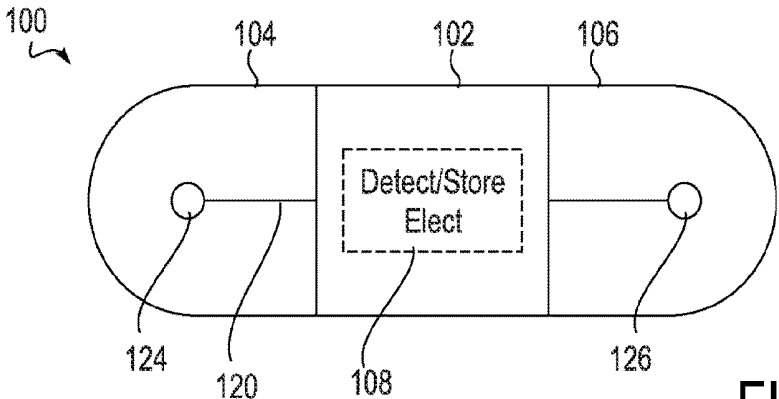

FIG. 1

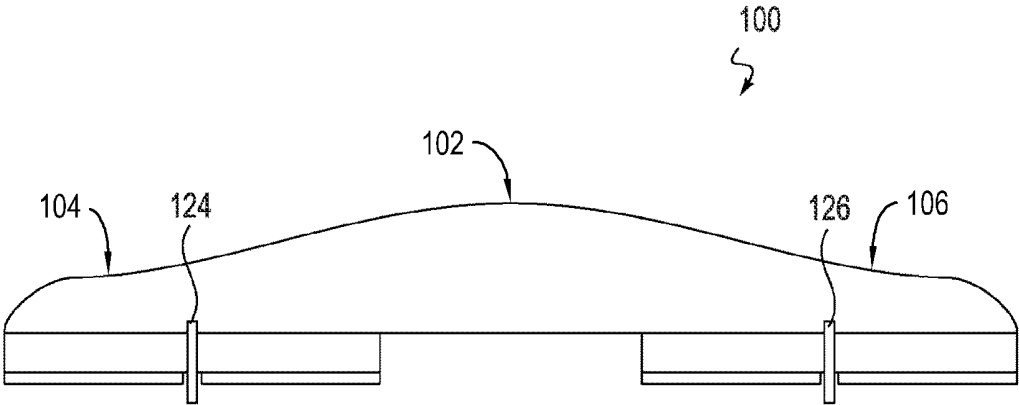

FIG. 1A



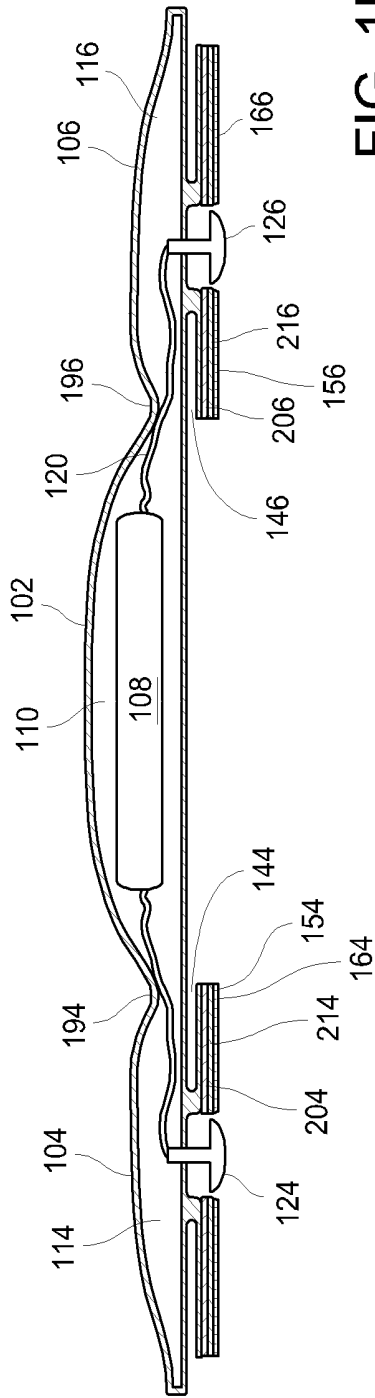

FIG. 1D

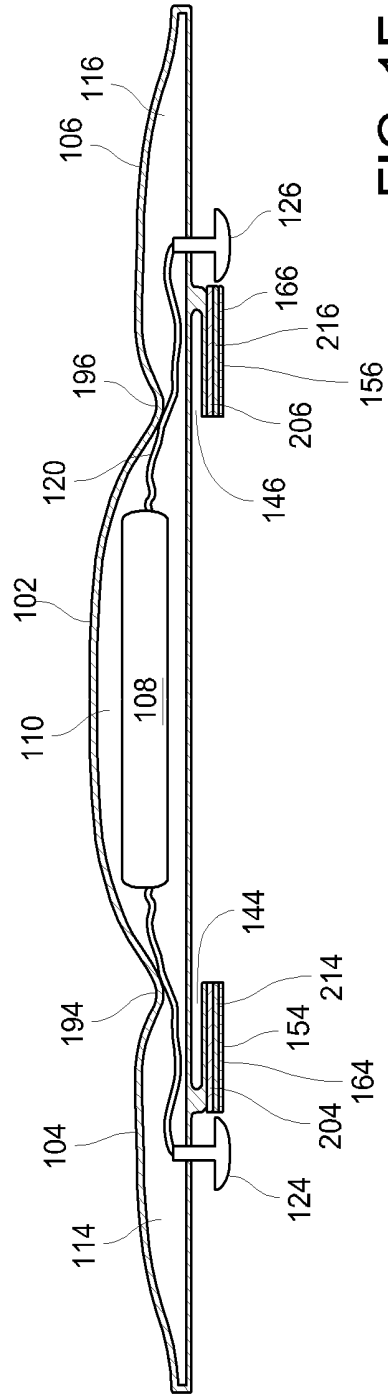

FIG. 1E

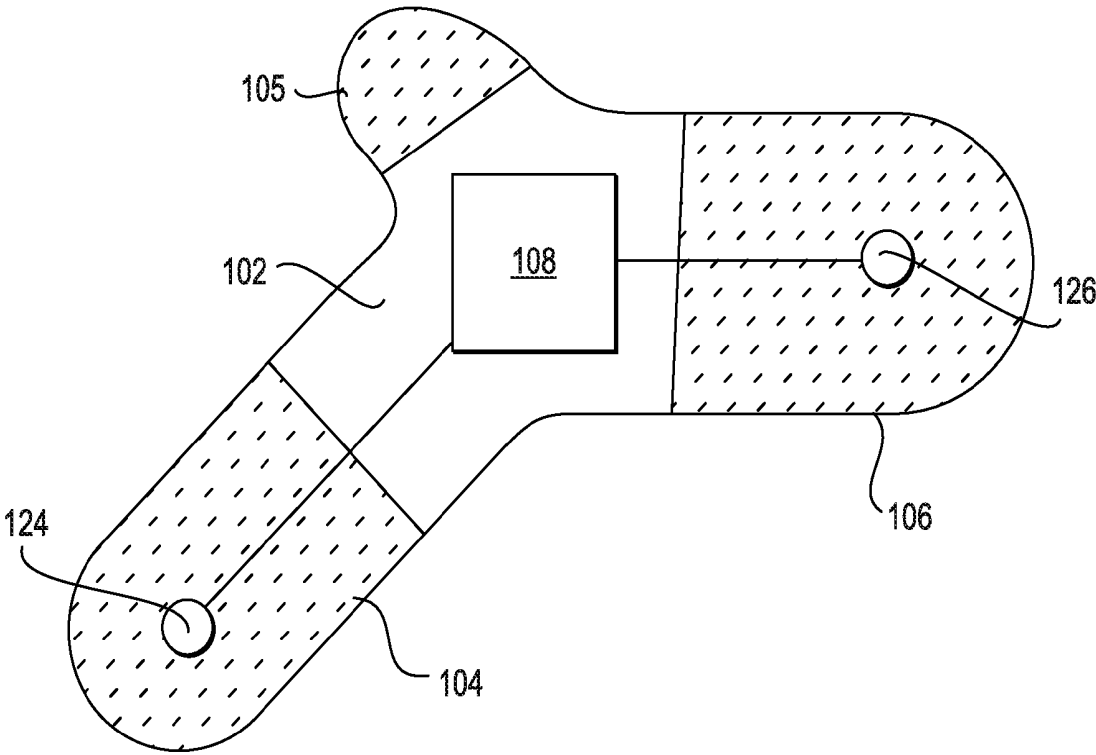

FIG. 1F

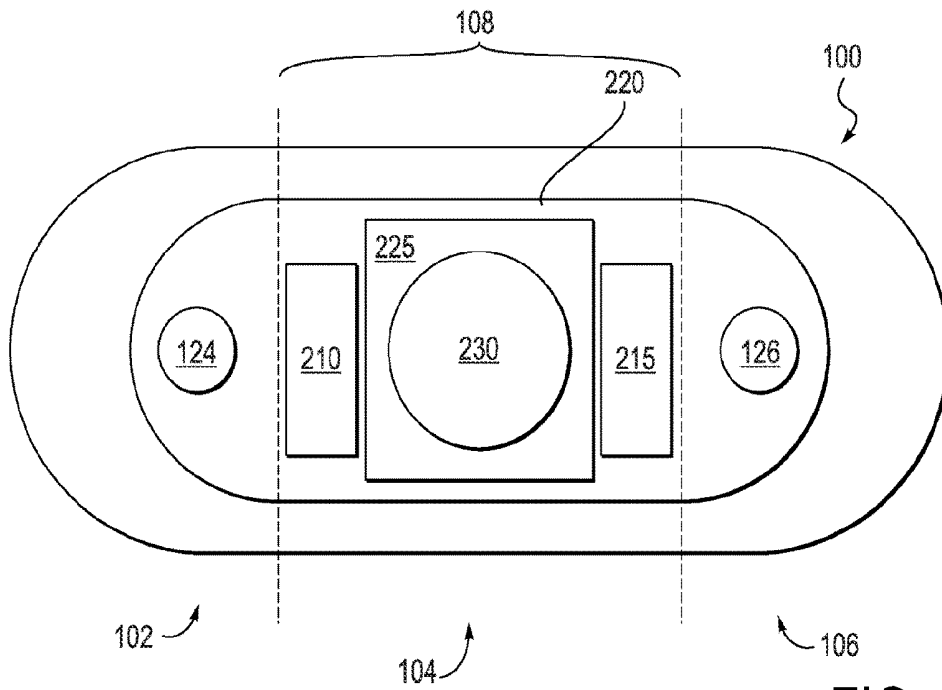

FIG. 2A

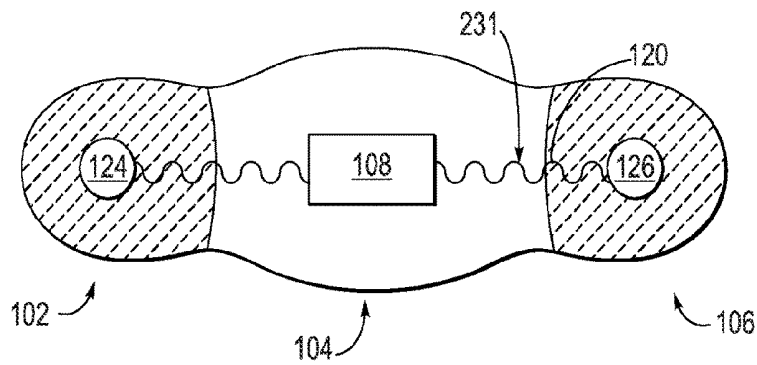

FIG. 2B

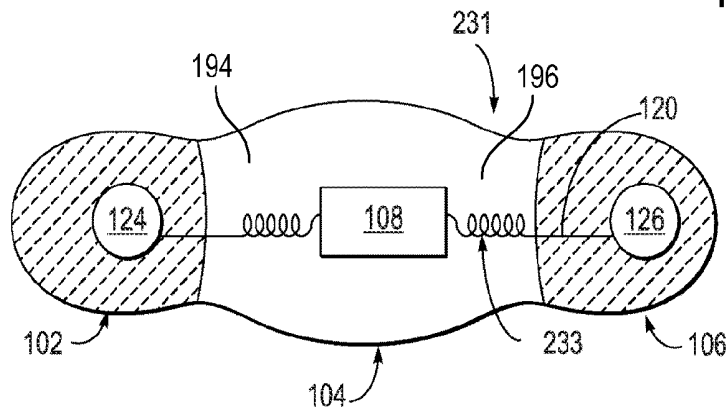

FIG. 2C

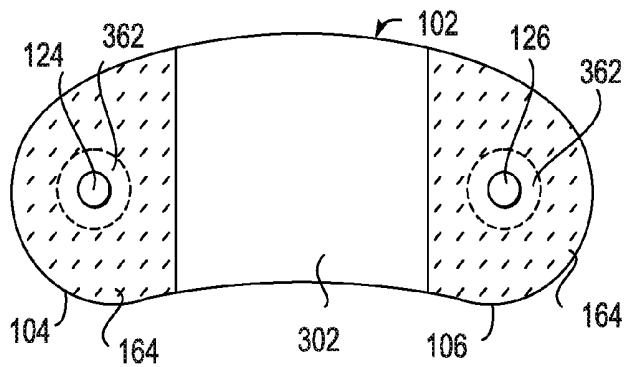

FIG. 3

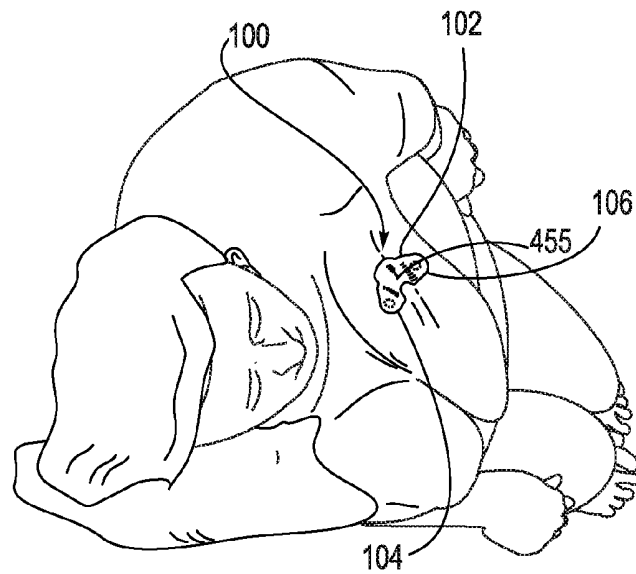

FIG. 4A

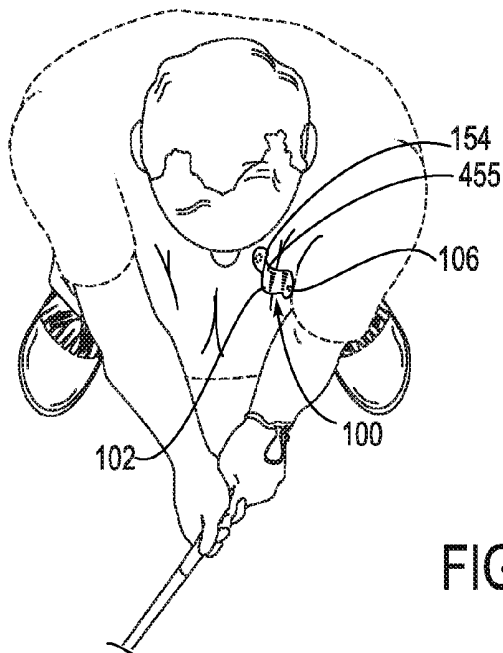

FIG. 4B

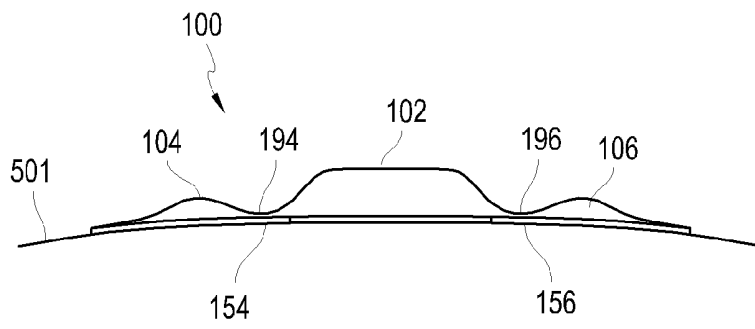

FIG. 5A

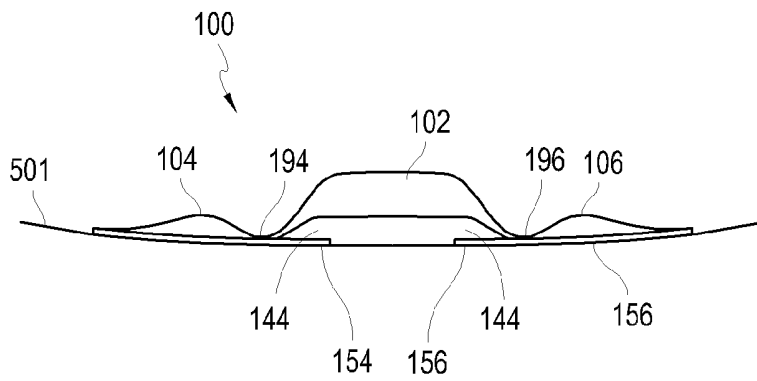

FIG. 5B

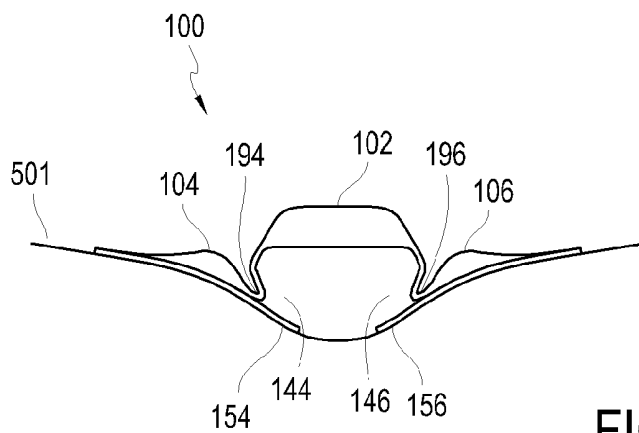

FIG. 5C

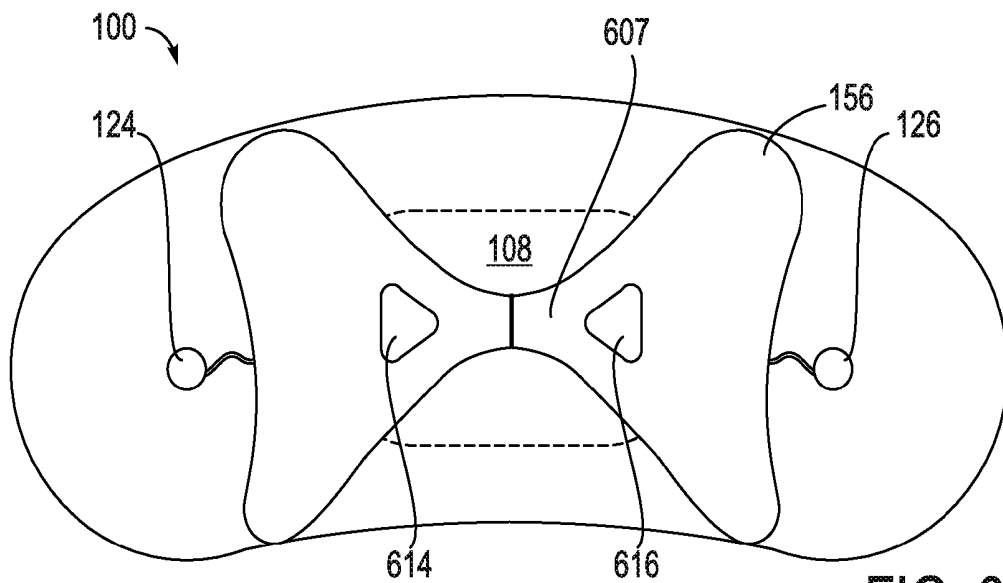

FIG. 6A

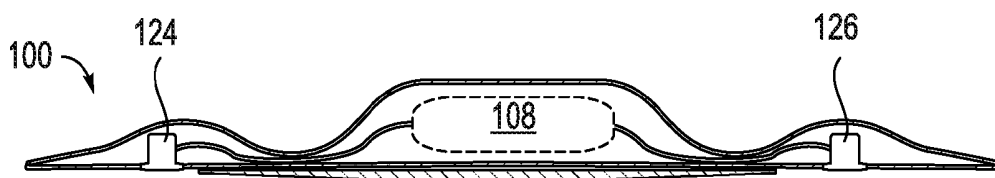

FIG. 6B

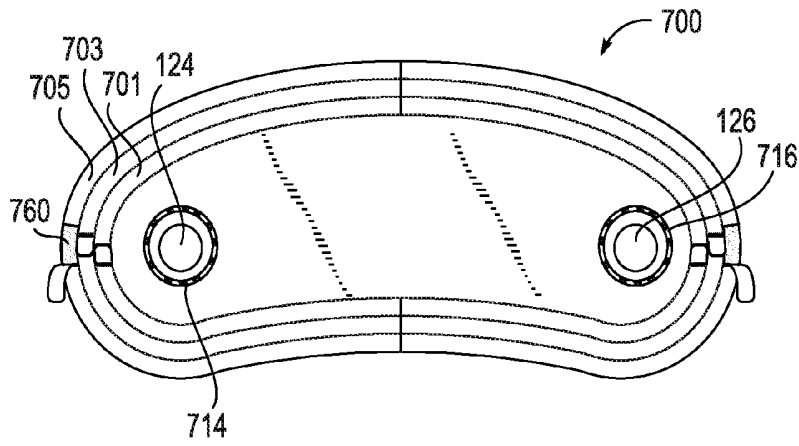

FIG. 7A

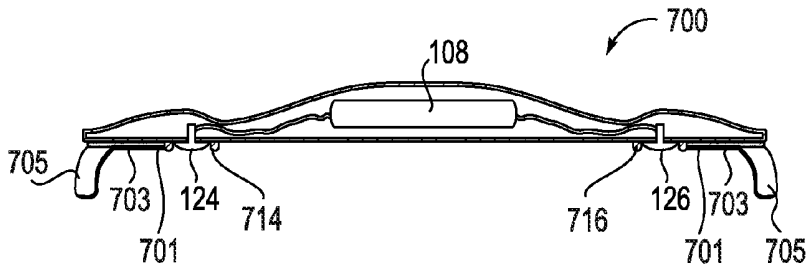

FIG. 7B

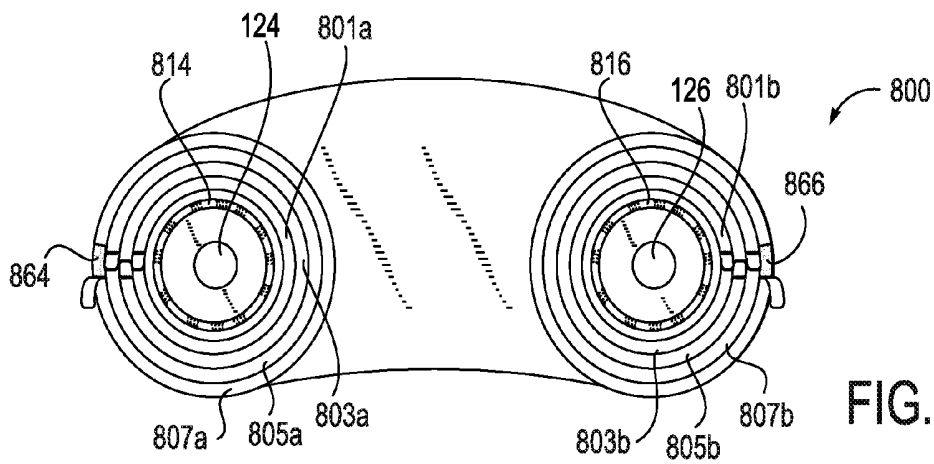

FIG. 8A

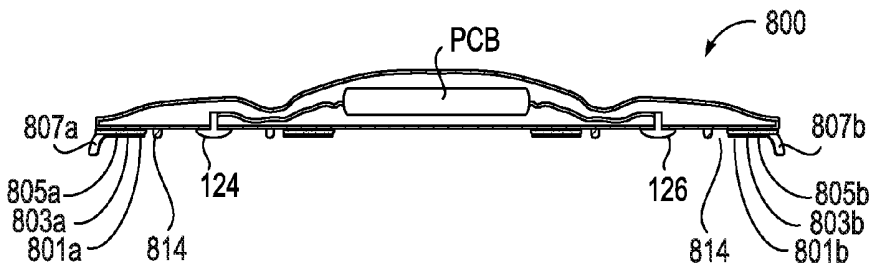

FIG. 8B

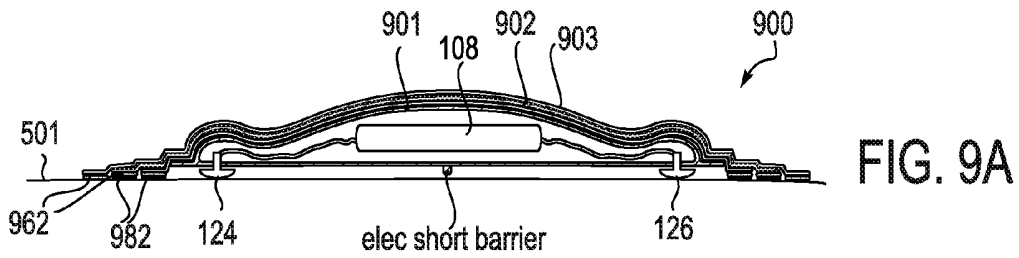

FIG. 9A

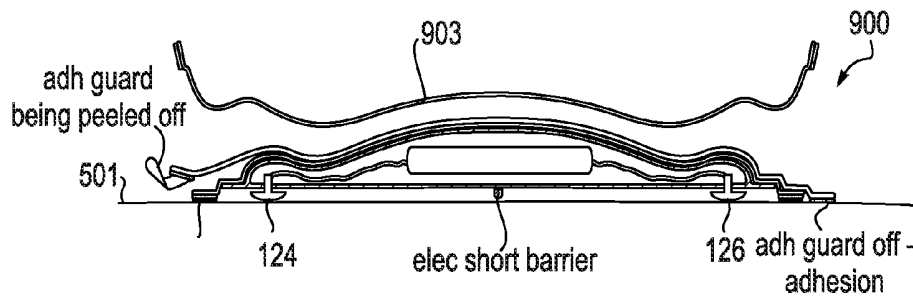

FIG. 9B

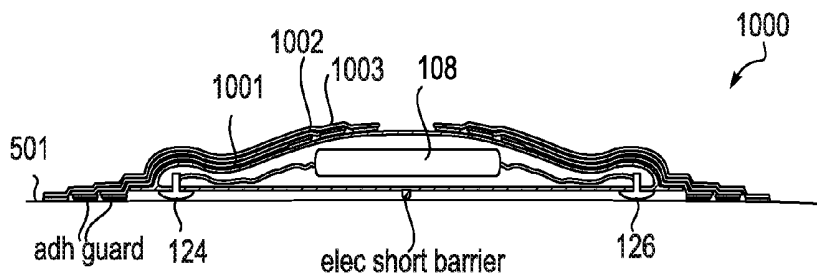

FIG. 10A

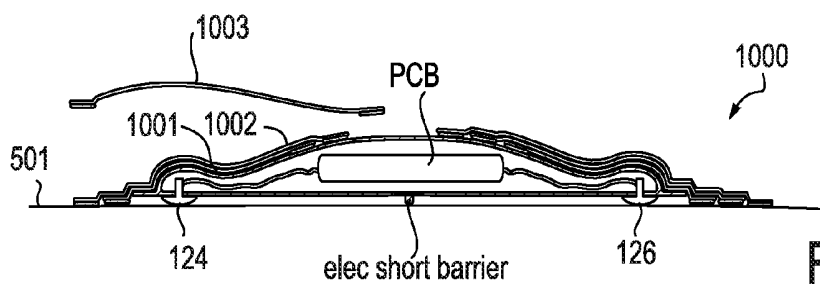

FIG. 10B

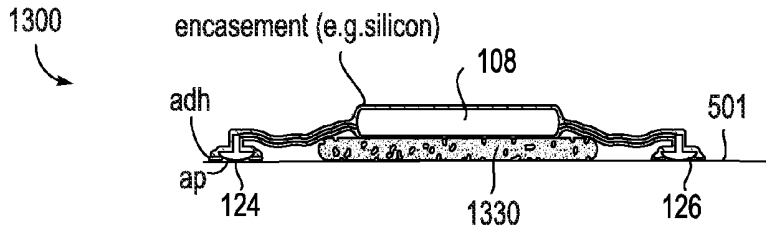

FIG. 11

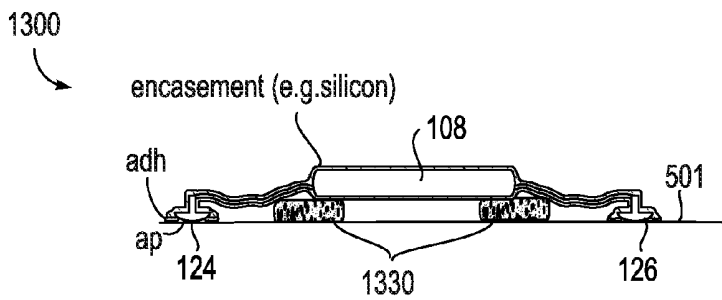

FIG. 12

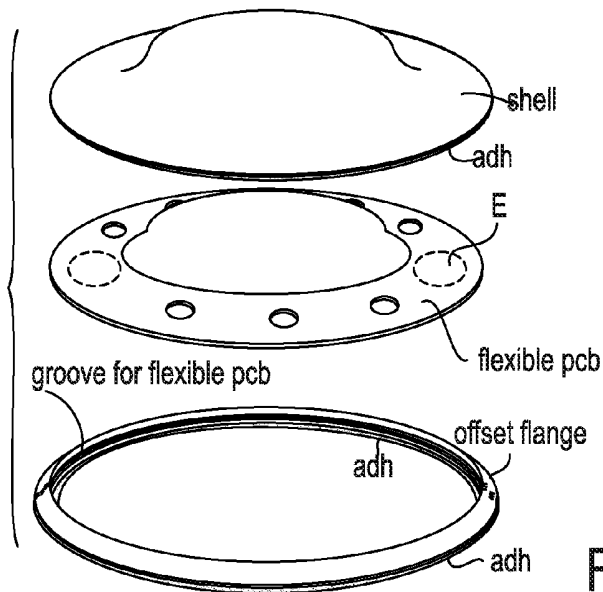

FIG. 13A

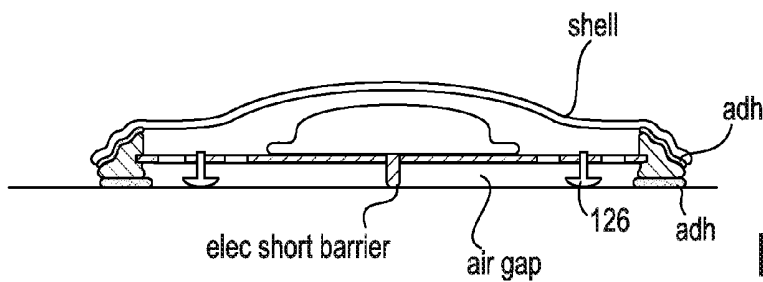

FIG. 13B

## DEVICE FEATURES AND DESIGN ELEMENTS FOR LONG-TERM ADHESION

### CROSS-REFERENCE TO RELATED APPLICATIONS

This application is a continuation of U.S. application Ser. No. 13/563,546, filed Jul. 31, 2012, which issued as U.S. Pat. No. 8,538,503 on Sep. 17, 2013 titled "Device Features and Design Elements for Long-Term Adhesion", which claims priority to U.S. patent application Ser. No. 13/106,750, filed May 12, 2011, which issued as U.S. Pat. No. 8,560,046 on May 12, 2011, which claims priority to U.S. Provisional Patent Application No. 61/334,081, filed May 12, 2010, entitled "Device Features and Design Elements for Long-Term Adhesion," which is incorporated by reference as if fully set forth herein.

### INCORPORATION BY REFERENCE

All publications and patent applications mentioned in this specification are herein incorporated by reference to the same extent as if each individual publication or patent application was specifically and individually indicated to be incorporated by reference.

### FIELD OF THE INVENTION

This application relates to devices worn on a body for monitoring, recording, reporting and/or treating the person wearing the device. Improvements in the device design elements and functionality are disclosed for maintaining the device in contact with and operational for extended periods of time, typically longer than 24 hours.

### BACKGROUND OF THE INVENTION

The ability to adhere a medical device to a human body for a long-period of time is dependent on a variety of factors. In addition to the type and nature of the adhesive chosen, another factor is the mechanical design of the device. By design, this refers to, but is not limited to, the device shape, size, weight, flexibility, and rigidity. These design elements are influenced by a number of additional factors, including, but not limited to, where on the body the device will attach and the duration of the attachment, moisture conditions in that area, movement conditions in that area, stretching and contraction in that area, interactions with external factors in that area such as clothing, and purposeful and/or inadvertent interaction between the person wearing the device and the device.

As many are typically used on the body for less than 24 hours, devices have not been designed that can withstand longer-term adhesion. Hence, there is a need to implement device features and design elements that have the ability to enhance the likelihood of adhesion of a device to a human body for 24 hours or more, while accommodating the functionality, shape, size, weight, flexibility, and rigidity of a given device.

### SUMMARY

In one aspect of the invention, there is an electronic device for long-term adhesion to a mammal. The device has a housing containing an electronic component with a first wing and a second wing integrally formed with the housing. There is an electrode positioned on a bottom surface of each of the wings with the electrodes electrically connected to the electronic

component. An adhesive layer is provided for adhesion to a surface of the mammal. The adhesive layer is coated on a portion of the bottom surface of the wings. The adhesive layer is not coated on the electrode or on a bottom surface of the housing.

The electronic component in any of the devices described herein may include a processor having a memory with computer readable instructions to record signals from the first and second electrodes while the electronic device is attached to the mammal. The processor may be configured to only convert signals from the electrodes to digital signals, filter those signals and then store the signals in memory.

In another aspect, the device includes a flap connected to each of the wings. The flaps may extend below the housing. Additionally or alternatively, the adhesive layer is coated on a bottom surface of the flaps.

In another aspect, the device includes a connector segment. In one aspect, the connector segment configured to connect the flaps together. In other aspects, the connector segment is located at least partially below the housing. Still further, the connector segment is not attached to the housing.

In one alternative, the adhesive layer is coated on a bottom surface of the flap.

In still another aspect, the adhesive for adhesion to a surface of the mammal is an adhesive that can absorb fluids. In another aspect, the adhesive that can absorb fluids is a hydrocolloid adhesive. In another aspect, the adhesive for adhesion to a surface of the mammal is a pressure-sensitive adhesive. The pressure sensitive adhesive is selected from the group consisting of: a polyacrylate, a polyisobutylene, and a polysiloxane. In one alternative, the device includes a diffusion barrier between the adhesive layer and each of the wings. The device may also include an additional adhesive layer and material layer between the wing and the adhesive layer for adhesion to the mammal. The material layer is configured to prevent diffusion of adhesive components from the adhesive layer to the wing. The diffusion barrier may be made from polyester or other suitable synthetic material.

In one aspect of the device, all or substantially all of the electronic components are within the housing. In another aspect, the wing is free from electronic components. In one aspect, the wing is more flexible than the housing. In one alternative, the wings and the housing are made from the same material. In another aspect, the wings and the housing are made from different materials. In another, the wings are made from a fabric. In still another aspect, the material used to make the wings includes a synthetic fiber. In another alternative, the wing and the flap are composed of the same material.

In another alternative, the device includes a hinge portion between the housing and the wing. The hinge portion is configured to allow the device to bend between the housing and the wing. In one aspect, the hinge portion exists between a rigid portion of the device and a flexible portion of the device. In one alternative, the rigid portion of the device corresponds to the portion of the housing including the electronics and the flexible portion of the device includes a wing.

In one aspect, the bottom surface of the wing and the bottom surface of the flap are contiguous. In another aspect, the bottom surfaces of the wings, the flap, and the connectors are contiguous. In still other aspects, the flaps and the connector are contiguous.

In another aspect, the connector has at least one hole extending it. The hole may have any of a number of shapes such as circular, oval, round, or triangular.

In one aspect, the housing is thicker at a center of the housing than at edges of the housing.

In another aspect of the device, the housing is unattached to the mammal when the electrodes are in contact with the mammal.

In another alternative aspect of a device for long-term adhesion to a mammal, the device includes a housing with a first wing extending laterally from the housing and a second wing extending laterally from the housing without overlapping the first wing. There is a first electrode positioned on a bottom surface of the first wing and a second electrode positioned on a bottom surface of the second wing. An electronic memory is positioned within the housing. The electronic device is attached to the mammal. There is also an adhesive layer on a portion of a bottom surface of the first wing and the second wing. The adhesive is not on a bottom surface of the housing. When the device is worn on the mammal, only the adhesive layer(s) are attached to the mammal.

In one aspect, the portion of the bottom surface of the first wing and the second wing does not include the first and second electrodes. In one device aspect, the first wing, the second wing, and the housing are formed from the same material. In still another, the first wing, the second wing and the housing integrally form a monolithic structure. In other aspects, an angle formed by the first wing, the second wing, and the housing is between approximately 90° and 180°. In one variation, the angle is approximately 180°. In another variation, the angle is approximately 135°.

In still other embodiments, there is a first hinged portion between the first electrode and the processor and a second hinged portion between the second electrode and the housing.

In a further aspect, at least a portion of the body uncovered is not adhered to the mammal when signals from the electrodes are being recorded in memory.

In another aspect, the device includes a first flap connected to the first wing medial to the first electrode and a second flap connected to the second wing medial to the second electrode. Each flap may extend below the housing.

The device may also include a connector segment configured to connect the flaps together. In one aspect, the connector segment is located at least partially below the housing, but is not attached to the housing.

In another aspect, there is an electronic device that has a patch including a housing containing an electronic component. There is an electrode positioned on a bottom surface of the patch, the electrode electrically connected to the electronic component. There is a first adhesive strip extending around the perimeter of the patch and a second adhesive strip extending around the perimeter of the first adhesive strip. In one aspect, the first adhesive cover over the first adhesive strip and a second adhesive cover over the second adhesive strip. The first and second adhesive covers may be configured to be separably removed from the first and second adhesive strips. In one alternative, the first adhesive strip extends between the first and second adhesive covers. In another alternative, the adhesive in the first and the second adhesive strips is an adhesive that can absorb fluids. In still another aspect, the adhesive that can absorb fluids is a hydrocolloid adhesive. In one alternative, the adhesive in the first and the second adhesive is a pressure-sensitive adhesive. In some aspects, the pressure-sensitive adhesive is a polyacrylate, a polyisobutylene, or a polysiloxane.

In one alternative, the second adhesive strip partially overlaps the first adhesive strip. In another aspect, the second adhesive strip is attached to a shell, the shell overlapping the first adhesive strip.

In still another alternative device for long-term adhesion to a mammal, the device includes a patch having a housing with an electronic component contained therein. There is an electrode positioned on a bottom surface of the patch. The electrode electrically connected to the electronic component. There is a porous foam pad configured to be positioned between the electronic component and the mammal. In one aspect, the porous foam pad comprises a biocompatible foam material. In one variation, the porous foam pad can absorb fluids. In still another aspect, the porous foam pad is attached to the housing. In another, the porous foam pad is configured to be attached to the mammal. In another request, the porous foam pad can absorb fluids.

In one aspect of a method of applying an electronic device, there is a step of removing a first adhesive cover from the first wing of the electronic device to expose an electrode and an adhesive coated on a bottom surface of a first wing. There is a step of placing the exposed electrode into contact with the mammal by adhering the adhesive coated bottom of the first wing to the mammal. There is also a step of removing a second adhesive cover from the second wing of the electronic device to expose an adhesive coated on a bottom surface of the second wing and another exposed electrode. There is also a step of placing the another exposed electrode into contact with the mammal by adhering the adhesive coated bottom of the second wing to the mammal. After performing the removing and the placing steps, the housing is unattached to the mammal, but is held in position on the mammal using the adhesive coated bottoms of the first and the second wings.

In one alternative method of attaching a device, the electronic device includes a first flap connected to the first wing and a second flap connected to the second wing. The first and second flaps each extend below the housing. The step of removing a first adhesive cover from the first wing may also include exposing an adhesive coated on a bottom surface of the first flap. The step of removing a second adhesive cover from the second wing may also include exposing an adhesive coated on a bottom surface of the second flap.

In another alternative method of attaching a device, after performing the removing and the placing steps, the housing is held in position on the mammal using only the adhesive coated bottoms of the first wing, the second wing, the first flap and the second flap.

In an alternative aspect of a method of applying an electronic device to a mammal for long-term adhesion, the method includes removing a first adhesive cover from the first wing of the electronic device to expose an electrode and an adhesive coated on a bottom surface of the first wing. There is also a step of removing a second adhesive cover from the second wing of the electronic device to expose an adhesive coated on a bottom surface of the second wing and another exposed electrode. There is a step of placing the exposed electrodes into contact with the mammal by adhering the adhesive coated on the bottom of the first and the second wings to the mammal. After performing the removing and the placing steps, the housing is unattached to the mammal, but is held in position on the mammal using the adhesive coated bottoms of the first and the second wings.

There is also provided a method of applying an electronic device to a mammal for long-term adhesion wherein the electronic device includes a patch. The patch includes an electronic component along with an electrode positioned on a bottom surface of the patch and electrically connected to the electronic component. There is a first adhesive strip extending around the perimeter of the patch and a second adhesive strip extending around the perimeter of the first adhesive strip. One aspect of a method of applying the device includes a step of

removing an adhesive cover from the second adhesive strip of the electronic device. There is a step of applying pressure to the second adhesive strip to adhere the second adhesive strip to the mammal such that the electrode is in contact with the mammal. Then, after a period of time, removing an adhesive cover from the first adhesive strip of the electronic device. Next, there is the step of applying pressure to the first adhesive strip to adhere the first adhesive strip to the mammal such that the electrode remains in contact with the mammal.

In another alternative method of applying an electronic device to a mammal for long-term adhesion, the electronic device includes a patch, an electronic component, and an electrode positioned on a bottom surface of the patch and electrically connected to the electronic component. There is a first adhesive strip extending around the perimeter of the patch. The method includes a step of applying pressure to a first adhesive strip to adhere the first adhesive strip to the mammal such that the electrode is in contact with the mammal. After a period of time, placing a second adhesive strip around the perimeter of the first adhesive strip. Then there is the step of applying pressure to the second adhesive strip to adhere the second adhesive strip to the mammal such that the electrode remains in contact with the mammal.

Any of the above described devices may include additional aspects. A device may also include a first wire connecting the first electrode and the processor or an electronic memory and a second wire connecting the second electrode and the processor or an electronic memory. The first and second wires extend within the body and the first and second wings. In one aspect, the first and second wires extend within and are completely encapsulated within the body and the first and second wings. In one aspect, a conduit is provided within the body and the wings and the wires pass through the conduit. In one alternative, the conduit extends from the processor or electronic memory to an electrode so that the wire is completely within the conduit. In still other aspects of the devices described above, the first and second wires connecting the electrodes to the processor or electronics each include slack between the electrode and the processor. In one aspect, the slack is located in a portion of each wing that is configured to bend or flex. In another aspect, the slack is a portion of the wire within the wing and at least partially coiled about the first or the second electrode. In still other aspects, the slack is provided by a portion of the wire formed into a coil, a wave pattern, or a sinusoidal pattern along its length the connection point on the electronics to the connection point on the electrode.

In still other alternatives, the devices described above may be applied to any of a wide variety of conventional physiological data monitoring, recording and/or transmitting devices. Any of the improved adhesion design features and aspects may also be applied to conventional devices useful in the electronically controlled and/or time released delivery of pharmacological agents or blood testing, such as glucose monitors or other blood testing devices. Additional alternatives to the devices described may include the specific components of a particular application such as electronics, antenna, power supplies or charging connections, data ports or connections for down loading or off loading information from the device, adding or offloading fluids from the device, monitoring or sensing elements such as electrodes, probes or sensors or any other component or components needed in the device specific function. In still other aspects, the electronic component in any of the above devices is an electronic system configured for performing, with the electronic signals of the mammal detected by the electrodes, one or more or any combination of or the following electronic functions: monitoring,

recording, analyzing, or processing using one or more algorithms electronic signals from the mammal. Still further, any of the devices described above may include appropriate components such that the device is used to detect, record, process or transmit signals or information related to signals generated by a mammal to which the device is attached including but not limited to signals generated by one or more of EKG, EEG and/or EMG.

#### BRIEF DESCRIPTION OF THE DRAWINGS

The novel features of the invention are set forth with particularity in the claims that follow. A better understanding of the features and advantages of the present invention will be obtained by reference to the following detailed description that sets forth illustrative embodiments, in which the principles of the invention are utilized, and the accompanying drawings of which:

FIG. 1 is a top view of a patch having two wings;

FIG. 1A is a representative cross-section of an embodiment of the patch in FIG. 1;

FIG. 1B is a representative cross-section of another embodiment of the patch in FIG. 1;

FIG. 1C is a representative cross-section of another embodiment of the patch in FIG. 1;

FIG. 1D is a representative cross-section of another embodiment of the patch in FIG. 1;

FIG. 1E is a representative cross-section of another embodiment of the patch in FIG. 1;

FIG. 1F is a top view of a patch having three wings illustrating an alternative electrode-electronics-electrode orientation;

FIG. 2A is a schematic drawing of the electronics contained within a patch;

FIG. 2B is a schematic drawing of a patch with wiring having slack in the form of undulations between electronics and electrodes;

FIG. 2C is a schematic drawing of a patch with wiring having slack in the form of a coil between electronics and electrodes;

FIG. 3 is the bottom view of a patch having adhesive thereon;

FIG. 4A shows a patch as worn by a person rolled to the side;

FIG. 4B shows a patch as worn by a person playing golf;

FIG. 5A shows a patch in response to a concave bend of the skin;

FIGS. 5B and 5C show a patch in response to a convex bend of the skin;

FIG. 6A is a bottom view of a patch having a connector between two flaps;

FIG. 6B is a cross-section of the patch of FIG. 6A;

FIG. 7A is a bottom view of a patch having multiple covers forming strips of adhesive;

FIG. 7B is a cross-section of the patch of FIG. 7A;

FIG. 8A is a bottom view of a patching having multiple covers forming strip of adhesive around each electrode;

FIG. 8B is a cross-section of the patch of FIG. 8A;

FIGS. 9A and 9B show a patch having multiple layers formed thereon;

FIGS. 10A and 10B show a patching having multiple layers formed thereon, each layer having multiple patches of adhesive;

FIG. 11 shows a patch having an open cell support;

FIG. 12 shows a patch having an annular open cell support;

FIG. 13A shows a patch having a protective shell thereon; and

FIG. 13B shows a cross-section of the patch of FIG. 13A.

## DETAILED DESCRIPTION

The following device features and design elements can be implemented into any device being adhered to the human body for a long-period of time, typically greater than 24 hours. As an example, the following device features and design elements can be used for long-term adhesion of a cardiac rhythm monitoring patch (“patch”) to the chest of a person.

Referring to FIGS. 1 and 1A, a patch 100 for long term adhesion includes a housing 102. The housing 102 can be formed from any flexible, durable material, such as a biocompatible polymer, for example silicone. The housing 102 can include electronic components 108 therein. As shown in FIG. 2, the electronics 108 can include a printed circuit board 220, a battery 225, and a communications port mounted on the printed circuit board 220. The printed circuit board 220 can include analog circuits 210, digital circuits 215, and an activation or event notation button or switch 130. The electronics 108 can be used, for example, to record continuous physiological signals from a mammal wearing the patch 100. A system for continuously recording data is described further in co-owned U.S. application Ser. No. 11/703,428, filed Feb. 6, 2007, the entire contents of which are incorporated by reference herein.

As shown in FIGS. 1 and 1A, wings 104, 106 can be connected to the housing 102. The wings 104, 106 can be integral with the housing 102 and, in some embodiments, can be formed of the same material as the housing 102. The wings 104, 106 can be more flexible than the electronic components 108, which can be substantially rigid. An electrode 124, 126 can extend through a bottom surface of each wing 104, 106. The electrodes can be positioned to detect an ECG of a mammal wearing the patch 100 for processing by the electronics 108. For example, the electrodes can be more than 2 cm apart, such as more than 3 cm apart, for example at least 6 cm apart. The electrodes 124, 126 can be integral with the wings 104, 106 so as to be inseparable from the wings 104, 106 when the patch is in use.

For a patch 100 that is entirely flexible and can conform, stretch, and adapt to the movement and conditions of the chest underneath the device, adhesive can be placed over the entire surface of the device that is in contact with the body, except for areas where sensors, electronics, or others elements such as electrodes are interacting with the body related to the functioning of the device may be incorporated. Thus, as shown in FIG. 3, an adhesive layer 166 can coat the bottom of the patch 100 for attachment to the skin. For a patch 100 in which there may be some areas that are not completely flexible and may not be able to stretch or contract (e.g., the electronics 108), adhesive may be excluded from the portion of the patch 100 underneath these areas. Thus, for example, the bottom surface 302 of the housing 102, which contains the electronics, can remain free from adhesive. As shown in FIG. 1A, by not coating adhesive on a bottom surface of the housing 102, the housing 102 can float above the adhered portions, allowing for increased flexibility of the patch, as will be discussed further below. Further, as shown in FIG. 3 the bottom surface of the electrodes 124, 126 can remain free of adhesive. For example, a ring 362 without adhesive can be formed around each electrode 124, 126 to separate the electrodes from the adhesive 164. The adhesive can be, for example, a pressure-sensitive adhesive, such as polyacrylate, polyisobutylene, or a polysiloxane. Alternatively, the adhesive can be a hydrocolloid which advantageously absorbs water.

The wings 104, 106 and the housing 102 can form a smooth, contiguous outer surface to the patch 100. As shown

in FIG. 1A, when viewed from the top, the housing 102 and wings 104, 106 can together form an oblong substantially oval shape. Further, the housing 102 can have a thickness that is greater than the thickness of the wings 104, 106. The housing 102 and each of the wings 104, 106 when viewed in profile, can each form a dome with a height that is greater at the center than at the ends of the respective component, i.e. some or all of the components can be tapered at the ends and/or sides.

The electronics 108 can extend along only a portion of the distance between the electrodes 104, 106. For example, the electronics can occupy less than 90% of the distance between the electrodes, for example less than 80%. By having the electronics 108 in a relatively limited space between the electrodes 124, 126, the flexibility of the patch 100 can be increased.

The housing 102 can provide a watertight enclosure 110 for electronic components 108 of the patch 100. The electronics 108 can be unattached to the housing 102 such that the electronics 108 are free to move within the watertight enclosure 110. Allowing the relatively rigid electronics 108 to move freely within the flexible housing 102 advantageously enhances the overall flexibility of the patch 100. The wings 104, 106 can each have a watertight enclosure 114, 116 formed therein, which can be contiguous with the watertight enclosure 110 of the housing 102.

Wiring 120 or other suitable electrical connections can connect the electrodes 124, 126 with the electrical components 108 of the housing. In some embodiments, as shown in FIGS. 1B-1E, the contiguous nature of the enclosure 110 and the enclosures 114, 116 allows the wiring 120 to extend within the patch 100 from the electrodes 124, 126 to the electronic components 108. In other embodiments, one or more channels, tubes, or conduits are provided between the housing 102 and the wings 104, 106, to provide space for the wiring 120. The tube or channel may be straight or curved. In use, the wire 120 positioned in the enclosures 110, 114, 116 or in the tube or channel may move relative thereto in order to remain flexible within the housing. In one aspect, the flexible channels or tubes are formed within the device housing so that the housing, as it is being stretched, does not affect the ability of the components, such as wires, that may connect more rigid structures, to move or elongate.

As shown in FIG. 1, the wire 120 is straight with a direct line of connection between the electrodes 124, 126 and the electronics 108. FIG. 1 illustrates an embodiment where the length of the wires 120 connecting the electrodes 124, 126 to electronics 108 are about the same distance as the spacing between the electrode connection point on electronics 108 and the electrodes 124, 126. FIG. 1F also illustrates a straight line type connection where wire 120 length is nearly the same as the spacing between the electronics 108 and the electrodes 124, 126. However, as a patient moves, the patch 100 flexes along with patient movement. As shown in FIGS. 4B and 5C, patch flexion may be severe and is likely to occur during long term monitoring. In order to address the possible dislocation or breakage of the wire 120, the length or shape of the wire 120 may be selected to permit patch flexion to occur with little risk of wire 120 pulling from the electrode or electronics. Numerous alternatives are possible to compensate for patch flexion. Exemplary confirmations include undulations or zig-zags 231 as shown in FIG. 2B, coils 233 as shown in FIG. 2e, or a configuration that partially or fully wraps around an electrode. In some embodiments, other components, such as the circuit board or electrodes, can alternatively or additionally contain additional length to help accommodate stretch or displacement. When the patch 100 is attached to a mammal,

the slack in the wiring **120** allows the patch **100** to flex while not placing stress on the wiring **120**.

While the illustrated embodiments of FIGS. 1A-1D show only two wings and show the electrodes and electronics in a direct line in an approximate 180 degree alignment of electrode **124** to electronics **108** to electrode **126**, other configurations are possible. For example, as shown in FIG. 1F, the wings **104**, **106** are arranged in an orientation less than 180 degrees. In the illustrated embodiment, the angle formed by the electrodes and the electronics is about 135 degrees. Other ranges are possible so long as electrode spacing is provided to permit ECG monitoring. The orientation of the wings **104**, **106** to the housing **102** also illustrates the use of an additional adhesive tab **105**. Tab **105** is shown as a semicircular extension of the body **102**. The bottom of tab **105** can include adhesives as described herein and is used to provide additional anchoring of the patch to the patient. The tab **105** may be formed in any of a number of different shapes such as rectangles, ovals, loops or strips. Further, in some embodiments, the tab **105** can function similar to a wing, e.g., include an electrode there-through that connects to the electronics **108**.

Referring to FIGS. 1A-1D and 2B-2C, a hinge portion **194**, **196** in the patch **100** can extend between each electrode **124**, **126** and the electronics **108**. The hinge portions **194**, **196** can have a thickness less than the thickness of surrounding portions of the patch **100**. For example, if the hinge portions **194**, **196** are in the wings **104**, **106**, then the thickness can be less than adjacent portions of the wings. Likewise, the hinge portions **194**, **196** can have a width less than adjacent portions of the patch **100**, e.g., less than adjacent portions of the wings **104**, **106**. Alternatively, the hinged portion can be formed by the adjunct between a rigid portion, i.e. the electronics **108**, and a more flexible portion. The hinged portion allows the patch **100** to bend between the housing **102** and wings **104**, **106** to compensate for any movement caused by the patient. As shown in FIGS. 2B and 2C, the slack in the wiring **120** can be placed at or proximal to the hinge portions **194**, **196** to allow for bending at the hinge portions **194**, **196** without pulling or breaking the wiring **120**.

Referring to FIGS. 4A and 4B, having adhesive on the bottom of the patch **100** except in the areas substantially around the electrodes and directly underneath the housing **102** can create a floating section **455** over the skin of the mammal to which the patch **100** is attached. The floating section **455** can house the more rigid or less flexible electronic components while the flexible wings **104**, **106** can be adhered to the skin and provide the flexibility necessary to hold the patch **100** in place. As a result of this selective use of adhesive areas and non-adhesive areas, the limitation on device flexibility imposed by the less flexible floating section can be mitigated or reduced by hounding the floating section with one or more adhered flexible areas. The flexible sections can thus adhere to the body if the underlying portion of the body is stretched and/or contracted while the floating section is free to move above the skin, for example if the person wearing the device rolls over (as shown in FIG. 4A) or is involved in activities that can otherwise cause movement of the skin (as shown in FIG. 4B).

Referring back to FIGS. 1B-1E, each wing **104**, **106** can include a material layer **214**, **216** between the adhesive **164**, **166** and the wings **104**, **106**. The material layer **214**, **216** can be, for example, a polyester layer. The material layer **214**, **216** can be attached to the patch **100** with a layer of adhesive **204**, **206**. The adhesive **204**, **206** can be the same as the adhesive **164**, **166** or different. For example, the adhesive **204**, **206** could be a silicone adhesive. The material layer **214** can serve as a barrier to prevent diffusion or migration of adhesive

components, such as a tackifier, from the adhesive **164**, **166** into the wings **104**, **106** or housing **102**. The material layer **214** can thus advantageously serve to maintain the strength of the adhesive **104**, **106** over time.

Referring still to FIGS. 1B-1E, the patch **100** can further include a first flap **154** connected to the first wing **104** and a second flap **156** connected to the second wing **106**. The flaps **154**, **156** can both extend from a position on the wings **104**, **106** medial to the electrodes to a position below the housing **102**, such as below the electronics **108**. The flaps **154**, **156** can remain unattached to the housing **102**. As a result, gaps **144**, **146** can be formed between the flaps **154**, **156** and the housing **102**. The gaps can provide additional "floating" for the housing **102** and the relatively rigid components **108** contained therein.

In some embodiments, shown in FIG. 1B, the flaps **154**, **156** can be attached to the wings **104**, **106** with adhesive **134**, **136**. The adhesive **134**, **136** can be the same as the adhesive **164**, **166** or different. For example, the adhesive **134**, **136** could be a silicone adhesive. In other embodiments, shown in FIGS. 1C-1E, the flaps **154**, **156** can be integral with the wings **104**, **106**. For example, the flaps **154**, **156** can be solvent welded to and/or formed during the molding process of the wings **104**, **105** such that hinges **194**, **196** form below the wings **104**, **106**. Additionally or alternatively, one or more of the flaps **154**, **156** may be separably attached to the wings **104**, **106**. In some embodiments, shown in FIGS. 1B and 1C, the materials making up the flaps **154**, **156** can extend all the way to the lateral edge of the patch **100**. In other embodiments, shown in FIG. 1D, a flap can extend on each side of the electrodes, i.e. one flap can extend medially and the other laterally. In some embodiments, the lateral and medial—extending flaps are part of the same annular flap. In other embodiments, shown in FIG. 1E, the flaps and materials making up the flaps extend only from a position medial to the electrodes underneath the housing.

The Flaps **154**, **156** may be positioned in virtually any relationship to the adhered flexible area such that, when attached in use, the attachment of the flap or flaps effectively counteracts the expected external forces acting on the device, specifically those forces that may dislodge the adhered flexible areas. Further, in embodiments such as that shown in FIG. 1F where there are more than two wings, there can be a flap corresponding to each additional wing.

The adhesive layers **164**, **166** can coat all or a portion of the bottom of each of the flaps **154**, **156**. In some embodiments, the adhesive **164**, **166** extends continuously from the bottom surface of the wings **104**, **106** to the bottom surface of the flaps **154**, **156**, except for areas proximate to the electrodes **124**, **126**. Further, the top surface of the flaps **154**, **156**, i.e. the surface closest to the housing **102**, can remain free of adhesive to ensure that the housing **102** remains floating. In some embodiments, the only portion of the patch **100** including adhesive for adhesion to the skin can be the flaps **154**, **156**.

Referring to FIGS. 5A-5C, the naps **154**, **156**, can provide hinge-like behavior for the patch **100**. Thus, as shown in FIG. 5A, if the skin **501** is stretched or bent in a concave manner, the gaps **144**, **146** between the flaps **154**, **156** and the housing **102** can approach zero such that the patch **100** can sit substantially flat on the skin **501**. As shown, the hinge portions **194**, **196** between the housing **102** and wings **104**, **106** can provide additional flexibility for concave bends by flattening as the patch **100** is stretched. In contrast, as shown in FIGS. 5B and 5C, as the skin **501** is bent in an increasingly convex manner, the gaps **144**, **146** between the flaps **154**, **156** and the housing **102** can increase, thereby allowing the flexible wings **104**, **106** to remain adhered to the skin and the rigid housing

102 to float above skin. As shown, the hinge portions 194, 196 between the housing and the wings 104, 106 can provide additional flexibility for convex bends by folding inward as the patch 100 is bent.

When placed substantially flat on the skin 501, the patch 100 can have a height that extends no more than 2 cm off of the skin, such as no more than 1.5 cm off of the skin, when lying flat on the patient and no more than 4 cm, such as no more than 1 cm off of the skin when floating above the skin. The relatively low height of the patch 100 can enhance long-term adhesion by reducing the potential for the patch] 00 to snag or rip off of the skin.

Advantageously, the flaps 154, 156 can function as anchors for adhesion that mitigates shear force. The flaps 154, 156 can provide a different direction for the acute and chronic forces being experienced by the device due to stretching, contraction, or torsion to be spread out over both the flap as well as the flexible adhesive areas. Further, by pre-aligning the orientation of the floating section, adhered flexible area and the flaps, the device may be better able to tolerate (i.e., remain attached to the body and in use) and/or tailor the interaction with the forces acting on the device in order to better withstand the acute or chronic forces being experienced by the device. Tailoring the response of the device to the expected forces is one

Because the flaps can be used to counteract forces acting on a particular device, it is to be appreciated that the dimensions, flexibility, attachment technique, and/or orientation between a flap and another component may vary depending upon the purpose of a particular flap. Accordingly, a flap may have the same or different characteristics from another flap or component of the device. In one aspect, at least one flap is more flexible than the other flaps in a particular device. In another aspect, each of the flaps has similar flexibility. In still another aspect, at least one flap is more flexible than the device component to which it is attached or from which it originates. In still another aspect, at least one flap is less flexible than the device component to which it is attached or from which it originates.

Referring to FIGS. 6A and 6B, in one embodiment, the flaps 154, 156 may be augmented by a connector segment 607 used to join the flaps together. The connector segment 607 can extend below the housing 102, but remain unattached to the housing 102. As shown in FIG. 6A, the flaps 154, 156 and the connector 607 can together form a butterfly shape. In one embodiment, the connector segment 607 and the flaps 154, 156 are formed from a single piece of material. The connector segment 607 can be made of the same material as the flaps 154, 156 or of different material. In one embodiment, the bottom surface of the connector is covered with adhesive. In another embodiment, the bottom surface of the connector does not include any adhesive. Further, as shown in FIG. 6B, the connector segment 607 can be thicker in the middle, under the housing 102, than near the edges, i.e., closer to the electrodes. The variable thickness can help prevent the connector segment 607 from capturing moisture thereunder. The connector segment 607 can advantageously prevent the device from flipping when attached to the patient

The connector segment 607 can include one or more holes 614, 616. In some configurations, the connector segment may trap moisture and/or inadvertently stick to the body. The holes 614, 616 can advantageously minimize the potential for undesired sticking or moisture collection. The size, shape and placement of the holes mitigate or reduce the collection of moisture and/or undesired adhesive still providing a connector with sufficient structural integrity (i.e. the connector allows the flaps to be connected to one another in order to

prevent them from folding). Additionally or alternatively, the connector holes could also be made to preferentially allow forces to be distributed along certain axes of the connector in order to further maximize the ability of the device to adhere long-term in the face of significant acute and chronic forces due to stretching, contraction, and torsion.

Adhesive can be selectively applied to the connector and/or naps to provide the desired body attachment locations depending upon the specific use of the device. For example, one piece of material including flaps and the connector can be adhered along two or more edges and/or with adhesive only covering certain areas. In another aspect, at least a portion of the skin-contacting surface of the unitary nap connector structure does not include any adhesive. Additionally or alternatively, the connector segment incorporating the flaps may be integral parts of the larger device housing (e.g. could be molded as part of the device housing or enclosure).

In some embodiments, the patch 100 can include one or more release liners to cover parts of the adhesive prior to adhesion. As is particular to devices having multiple adhesive areas and/or multiple adhesive components (i.e., flaps and flexible sections), the manner of applying the device may be specifically detailed in order to ensure that the device and the adhesive portions are properly engaged. In one particular aspect, the release liners are removed in a particular order to minimize the likelihood that the device adhesive is misapplied. For example, a portion of the adhesive may be exposed first and used to affix the device to the body. Thereafter, a second set of adhesive liners may be removed to expose and affix one or more flaps to the body. A stepwise adhesive exposure method may be implemented during device application such that elements, such as the one or more flaps do not fold on themselves, for example.

Breaking up the areas in which the adhesive is used to adhere the device, whether it be splitting it up to rigid areas, to create flaps, to create connector segments with holes, of any of the other techniques described above may also have benefits in terms of preventing moisture bridges that could act as conducting pathways between electrical sensing elements, such as electrodes. Bridges of moisture could short-circuit electrical connections and/or prevent the proper functioning of the device, particularly if the device has an electrical function, such as sensing via electrodes.

In some applications, a long-duration patch may experience excessive forces due to acute (quick and/or rapid) or chronic (slow and/or prolonged) contraction, stretching, or torsion. In such applications, the hinge points between a floating rigid section and flexible adhered sections may be modified in order to align with and counteract or mitigate the predominant direction of the force acting on the patch. In some device situations or configurations, the strength and direction of the acute or chronic force may be so strong that the forces imparted on the device adhesive surfaces or components may be distributed differently in addition to or as an alternative to the hinge described above.

Further, the device construction can be made in such a way that the housing is fashioned so that the axes of the housing are structured and placed along or against the direction of various forces, possibly during certain states, such as sleeping, so that the device itself can help counteract these forces and improve long-term adhesion.

Advantageously, the patch described herein can provide long-term adhesion to the skin. Having the various flexible portions and/or hinged portions can compensate for stressed caused as the skin stretches or bends, while allowing the rigid portion to float about the skin. As a result, the devices described herein can adhere to the skin substantially continu-

ously for more than 24 hours, such as greater than 3 days, for example, greater than 7 days, greater than 14 days, or greater than 21 days.

Another mechanism for adhering a patch to the skin long-term is described with respect to FIGS. 7-10. As shown in the embodiments of FIGS. 7-10, one or more parts of the patch are used in a temporary fashion in order to improve adhesion. The adhesive used in the embodiments described below can include a hydrocolloid or a pressure-sensitive adhesive, such as polyacrylate, polyisobutylenes, or polysiloxane.

In one embodiment, shown in FIGS. 7A and 7B, the patch 700 can be surrounded with an adhesive 760 having multiple covers 701, 703, 705 thereon that can be peeled away in a sequence to expose strips of adhesive 760 underneath. The covers 701, 703, 705 can be concentric with one another and be configured to be pulled off separately and sequentially starting from the inside of the patch 700. Each additional exposed area of adhesive 760 can increase the adhesion life of the patch 700. Although only three covers are shown in FIG. 7A, other numbers, such as 2, 4, 5, or more are possible. Further, each electrode 124, 126 of the patch 700 can include a barrier 714, 716 to protect the electrodes 124, 126 from shortage.

In another embodiment, shown in FIGS. 8A and 8B, each electrode 124, 126 can be surrounded by a patch of adhesive 864, 866. Accordingly, a set of covers 801, 803, 805, 807 can be positioned sequentially around each of the electrodes 124, 126 over the adhesive 864, 866. The covers 801, 803, 805, 807 can be concentric with one another and be configured to be pulled off sequentially starting from the inside. Each additional exposed strip of adhesive 864, 866 can increase the adhesion life of the patch 100. Although only four covers are shown in FIG. 8A, other numbers, such as 2, 3, 5, or more are possible. Further, each electrode 124, 126 of the patch 800 can include a barrier 814, 816 to protect from shortage.

Referring to FIGS. 9A-9B, in other embodiments, shells or layers 901, 902, 903 can extend over all or a portion of the patch 900. Each layer 901, 902, 903 can include a strip of adhesive 962 on the bottom surface and an adhesion guard 982 protecting the adhesive. As shown in FIG. 913, as the patch 900 is worn over a period of time, the layers 901, 902, 903 can be sequentially removed. As a new layer is exposed, the adhesive guard 982 of that layer can be peeled away such that the adhesive 962 of the new layer can be used to adhere the patch 900 to the skin. In a similar embodiment, referring to FIGS. 10A-10B, each of the layers 1001, 1002, 1003 can include multiple portions of adhesive to help adhere the layer to both the skin and the patch itself. As with the embodiments of FIGS. 7-8, the number of layers in the embodiments of FIGS. 9 and 10 can vary. For example, there can be 2, 3, 4, or 5 or more layers.

In some embodiments, the layers or covers of the embodiments described herein can be added to the device over time to improve adhesion. Further, the multiple layers or covers of the embodiments described herein can be partially overlapped. Further, in some embodiments, the strips of adhesive can be overlapped.

Advantageously, the use of multiple covers or layers can assist in the adhesive performance of a base or core device because the added surface area or adhesive force of the combined outer layer aids in preventing layer pull away and/or may act to spread forces being experienced away from the core device by spreading those forces over a larger area.

Referring to FIGS. 11 and 12, an open cell structured support 1330 or porous foam can be used to support a more rigid or less flexible portion 1302 of the patch 1300. As shown in FIG. 11, the open cell structured support 1330 can fully fill

an area below the rigid portion 1302. Alternatively, as shown in FIG. 12, the open cell structured support 1330 can be an annular shape or have some other configuration that includes spaces between adjacent portions of the support. The open cell structured support 1302 may be attached to both the skin and to the rigid portion, to only the rigid portion, or to only the skin. Because of the open cell structure of the support, the flexible movement of the skin can be absorbed by the structure entirely or partially such that the rigid portion does not impact or has a reduced impact on the ability of the device to accommodate movement and remain affixed. In addition, the open cell support may have a thickness selected to enhance patient comfort so that the more rigid portion of a device does not push against the skin. In one aspect, the open cell structure is a biocompatible foam material. In another aspect, the open cell material is positioned between an electronics module on the device and the skin when worn by a patient. The open cell support can advantageously absorb fluids to keep the electrodes from shorting.

Referring to FIG. 13, the patch can have a shell design. Adhesive can be placed on the perimeter edge of the bottom ring. The circuit board and electrode unit can be dropped into the bottom ring, and a shell can be dropped on top of the circuit board and electrode. The perimeter adhesive can create a watertight chamber therein.

The shape of a particular electronic device embodiment may vary. The shape, footprint, perimeter or boundary of the device may be a circle or circular (see FIG. 13A), an oval (see FIG. 1A, 2A), a triangle or generally triangular (see FIG. 1F) or a compound curve. Examples of a device embodiments having a compound curve shape are shown in FIGS. 2B, 2B, 3, 6A, 7A, and 8A. In some embodiments, the compound curve includes one or more concave curves and one or more convex curves. FIG. 3 illustrates a device having a convex surface along the top (where reference 102 indicates), a concave surface along the bottom and convex shaped edges around the electrodes 124, 126. FIGS. 2B and 2C illustrate a device embodiment having a convex shape on either side of the electronics 108 and around the electrodes 124, 126. The convex shapes are separated by a concave portion. The concave portion is between the convex portion on the electronics and the convex portion on the electrodes. In some embodiments, the concave portion corresponds to at least partially with a hinge, hinge region or area of reduced.

While described in the context of a heart monitor, the device adhesion improvements described herein are not so limited. The improvement described in this application may be applied to any of a wide variety of conventional physiological data monitoring, recording and/or transmitting devices. The improved adhesion design features may also be applied to conventional devices useful in the electronically controlled and/or time released delivery of pharmacological agents or blood testing, such as glucose monitors or other blood testing devices. As such, the description, characteristics and functionality of the components described herein may be modified as needed to include the specific components of a particular application such as electronics, antenna, power supplies or charging connections, data ports or connections for down loading or off loading information from the device, adding or offloading fluids from the device, monitoring or sensing elements such as electrodes, probes or sensors or any other component or components needed in the device specific function. In addition or alternatively, devices described herein may be used to detect, record, or transmit signals or information related to signals generated by a body including but not limited to one or more of EKG, EEG, and/or EMG.

What is claimed is:

1. An electronic device for long-term adhesion to a mammal, the device comprising:

a housing;

a physiologic data collection circuit contained in the housing;

at least two wings extending laterally from the housing, wherein each wing includes a hinge adjacent the housing;

an electrode integral with a bottom surface of each of the wings so as to be inseparable from the wings during use of the device, the electrodes electrically connected to the physiologic data collection circuit;

an adhesive layer on the bottom surfaces of the wings, wherein the adhesive layer provides adhesion to the skin of the mammal;

wherein the housing is attached to the mammal's skin only via the adhesive layer on the wings and is not directly attached to the skin of the mammal when the electrodes are in contact with the mammal;

wherein each hinge extends from the housing to each adhesive layer, each hinge configured to bend at a first intersection between the hinge and the housing and at a second intersection between the hinge and the adhesive layer;

wherein the wings are flexibly coupled to the housing to enable the electrodes to move toward and away from each other within a horizontal plane parallel to the mammal's skin, and to enable the housing to move toward and away from the mammal's body within a vertical plane perpendicular to the mammal's skin in response to movement of the mammal; and,

wherein the hinges are configured such that forces generated from the movement of the mammal are distributed along each hinge.

2. The electronic device of claim 1, wherein the wings are more flexible than the housing.

3. The electronic device of claim 1, wherein the wings and the housing are made from the same material.

4. The electronic device of claim 1, wherein the wings and the housing are made from different materials.

5. The electronic device of claim 1, wherein each hinge is thinner than an adjacent portion of the wing of which it is a part.

6. The electronic device of claim 1, further comprising a flap connected to each wing, the flaps extending below the housing but not directly attached to the bottom surface of the housing, wherein the adhesive layer extends onto a bottom surface of each flap.

7. The electronic device of claim 6, further comprising a connector segment configured to connect the flaps together without directly attaching to the bottom surface of the housing.

8. The electronic device of claim 1, further comprising a second adhesive layer functioning as an adhesion guard protecting the adhesive.

9. The electronic device of claim 8, wherein the second adhesive layer adds adhesive surface area to the first adhesive layer to distribute forces over a larger area.

10. The electronic device of claim 1, wherein the adhesive comprises an adhesive that can absorb fluids.

11. The electronic device of claim 10, wherein the adhesive comprises a hydrocolloid adhesive.

12. The electronic device of claim 1, wherein the adhesive comprises a pressure-sensitive adhesive.

13. The electronic device of claim 12, wherein the pressure-sensitive adhesive is selected from the group consisting of a polyacrylate, a polyisobutylene and a polysiloxane.

14. The electronic device of claim 1, further comprising: an additional adhesive layer between at least one wing and the adhesive layer; and

a material layer between the at least one wing and the adhesive layer.

15. The electronic device of claim 1, wherein the at least two wings comprise two wings extending from approximately opposite ends of the housing.

16. The electronic device of claim 15, further comprising at least one additional wing extending from the housing without overlapping the two wings.

17. The electronic device of claim 1, wherein the physiologic data collection circuit extends along only a portion of a distance between the electrodes.

18. The electronic device of claim 1, wherein the physiologic data collection circuit is configured to collect cardiac rhythm data from the mammal.

19. The electronic device of claim 1, wherein a shape of the boundary of the device is a compound curve.

20. The electronic device of claim 1, further comprising flaps configured to counteract external forces acting to dislodge the device.

21. The electronic device of claim 1, further comprising an electronic memory within the housing, the electronic memory configured to store physiologic data.

22. A device for monitoring cardiac rhythms of a mammal, the device comprising:

a floating section configured to move toward and away from the body of the mammal;

a skin-adhering section extending laterally out from the floating section;

two electrodes integral with a bottom surface of the skin-adhering section and disposed along the bottom surface; an adhesive layer disposed along the bottom surface of the skin-adhering section except along portions of the bottom surface containing the electrodes, wherein the adhesive layer is not disposed along a bottom surface of the floating section;

electronics disposed in the floating section, the electronics comprising an electronic memory, the electronic memory configured to store physiologic data;

wherein, when the device is worn on the mammal, only the adhesive layer is directly attached to the mammal, and the floating section is not directly adhered to the mammal such that the floating section can move toward and away from the body of the mammal in response to movement of the mammal; and,

wherein the floating section is configured such that forces generated from the movement of the mammal are distributed along an area between the adhesive layer and the electronics such that the generated forces are not concentrated at a single location.

23. A device as in claim 22, wherein the skin-adhering section includes two hinge portions, each hinge portion located adjacent to a connection of the skin-adhering section with the floating section.

24. An electronic device for long-term adhesion to a mammal, the device comprising:

a housing;

a physiologic data collection circuit contained in the housing;

at least two wings extending laterally from the housing, wherein each wing includes a hinge portion adjacent the housing;

an electrode carried by a bottom surface of each of the wings, the electrodes electrically connected to the physiologic data collection circuit;

an adhesive layer on the bottom surfaces of the wings, wherein the adhesive layer provides adhesion to the skin of the mammal, and wherein the housing is attached to the mammal's skin via the adhesive layer on the wings and is not directly attached to the skin of the mammal when the electrodes are in contact with the mammal;

wherein the wings are flexibly coupled to the housing to enable the electrodes to move toward and away from each other within a horizontal plane parallel to the mammal's skin, and to enable the housing to move toward and away from the mammal's body within a vertical plane perpendicular to the mammal's skin, in response to movement of the mammal; and,

wherein the hinge portions are configured such that forces generated from the movement of the mammal are distributed along each hinge portion.

**25.** The electronic device of claim **24**, further comprising an electronic memory within the housing, the electronic memory configured to store physiologic data.

\* \* \* \* \*

专利名称(译)	设备特征和设计元素，用于长期粘合		
公开(公告)号	<a href="#">US9241649</a>	公开(公告)日	2016-01-26
申请号	US13/890144	申请日	2013-05-08
申请(专利权)人(译)	IRHYTHM TECHNOLOGIES, INC.		
当前申请(专利权)人(译)	IRHYTHM TECHNOLOGIES, INC.		
[标]发明人	KUMAR UDAY N LIVINGSTON PETER H DAY MARK J PARK SHENA H WILLIS WILLIAM F RIGHTER WILLIAM H BAHNEY TIM		
发明人	KUMAR, UDAY N. LIVINGSTON, PETER H. DAY, MARK J. PARK, SHENA H. WILLIS, WILLIAM F. RIGHTER, WILLIAM H. BAHNEY, TIM		
IPC分类号	A61B5/04 A61B5/00 A61B5/0408 B31B50/62		
CPC分类号	A61B5/04087 A61B5/6833 A61B2560/0406 A61B2560/0468 Y10T156/10 A61B5/0408 A61B5/0478 A61B5/68335 A61B5/04085 A61B5/0488 A61B5/6832		
代理机构(译)	KNOBBE, MARTENS, 奥尔森 & BEAR LLP		
优先权	61/334081 2010-05-12 US		
其他公开文献	US20130245415A1		
外部链接	<a href="#">Espacenet</a> <a href="#">USPTO</a>		

摘要(译)

一种用于长期粘附到哺乳动物的电子装置包括具有电子元件的壳体。电子设备可包括第一机翼和第二机翼，每个机翼与壳体一体地形成。电极位于每个翼的底表面上，电极电连接到电子元件。提供粘合剂层以粘附到哺乳动物的表面。粘合剂层可以覆盖翼的底表面的一部分，但通常不覆盖电极或壳体的底表面。将电子设备应用于哺乳动物的方法包括从电子设备的第一和第二翼移除第一和第二粘合剂覆盖物以暴露电极和涂覆在每个翼的底表面上的粘合剂。

Uday N. Kumar, San Francisco, CA  
(US); Peter H. Livingston, San  
Francisco, CA (US); Mark J. Day, San