



US009011423B2

(12) **United States Patent**
Brewster et al.

(10) **Patent No.:** **US 9,011,423 B2**
(45) **Date of Patent:** **Apr. 21, 2015**

(54) **SYSTEMS AND METHODS FOR SELECTING, ACTIVATING, OR SELECTING AND ACTIVATING TRANSDUCERS**

(71) Applicant: **Kardium Inc.**, Richmond (CA)

(72) Inventors: **Jeffery Charles Brewster**, Burnaby (CA); **Daniel Martin Reinders**, Richmond (CA); **Daniel Robert Weinkam**, Coquitlam (CA)

(73) Assignee: **Kardium, Inc.** (CA)

(*) Notice: Subject to any disclaimer, the term of this patent is extended or adjusted under 35 U.S.C. 154(b) by 73 days.

(21) Appl. No.: **13/792,670**

(22) Filed: **Mar. 11, 2013**

(65) **Prior Publication Data**

US 2013/0310827 A1 Nov. 21, 2013

Related U.S. Application Data

(60) Provisional application No. 61/723,311, filed on Nov. 6, 2012, provisional application No. 61/670,881, filed on Jul. 12, 2012, provisional application No. 61/649,734, filed on May 21, 2012.

(51) **Int. Cl.**
A61B 18/00 (2006.01)
A61B 18/12 (2006.01)
(Continued)

(52) **U.S. Cl.**
CPC **A61B 18/1233** (2013.01); **A61B 5/053** (2013.01); **A61B 18/1206** (2013.01);
(Continued)

(58) **Field of Classification Search**
None
See application file for complete search history.

(56) **References Cited**

U.S. PATENT DOCUMENTS

4,114,202 A 9/1978 Roy et al.
4,164,046 A 8/1979 Cooley

(Continued)

FOREIGN PATENT DOCUMENTS

EP 0723467 B1 4/2002
WO 95/10320 A1 4/1995

(Continued)

OTHER PUBLICATIONS

International Search Report and Written Opinion mailed Aug. 2, 2013 issued in PCT/CA2013/050350.

(Continued)

Primary Examiner — Brian T Gedeon

(74) *Attorney, Agent, or Firm* — Rossi, Kimms & McDowell LLP

(57) **ABSTRACT**

Transducer-based systems can be configured to display a graphical representation of a transducer-based device, the graphical representation including graphical elements corresponding to transducers of the transducer-based device, and also including between graphical elements respectively associated with a set of the transducers and respectively associated with a region of space between the transducers of the transducer-based device. Selection of graphical elements and/or between graphical elements can cause activation of the set of transducers associated with the selected elements. Selection of a plurality of graphical elements and/or between graphical elements can cause visual display of a corresponding activation path in the graphical representation. Visual characteristics of graphical elements and between graphical elements can change based on an activation-status of the corresponding transducers. Activation requests for a set of transducers can be denied if it is determined that a transducer in the set of transducers is unacceptable for activation.

35 Claims, 21 Drawing Sheets

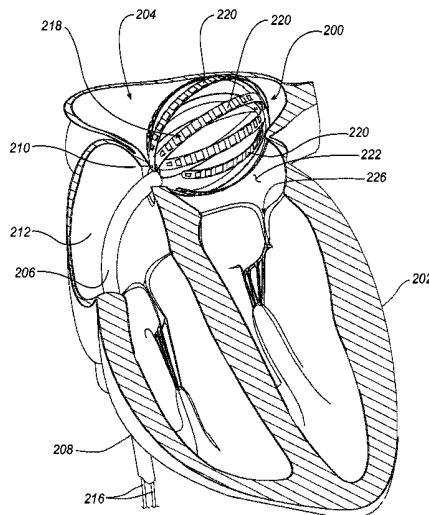

(51)	Int. Cl.		5,620,481 A	4/1997	Desai et al.
	<i>A61B 5/053</i>	(2006.01)	5,662,587 A	9/1997	Grundfest et al.
	<i>A61B 5/00</i>	(2006.01)	5,681,308 A	10/1997	Edwards et al.
	<i>A61B 5/042</i>	(2006.01)	5,681,336 A	10/1997	Clement et al.
	<i>A61B 5/01</i>	(2006.01)	5,687,723 A	11/1997	Avitall
	<i>A61B 18/14</i>	(2006.01)	5,687,737 A	11/1997	Branham et al.
	<i>A61N 1/362</i>	(2006.01)	5,697,285 A	12/1997	Nappi et al.
(52)	U.S. Cl.		5,713,896 A	2/1998	Nardella
	CPC	<i>A61B5/6858</i> (2013.01); <i>A61B 5/6869</i>	5,713,942 A	2/1998	Stern et al.
		(2013.01); <i>A61B 5/743</i> (2013.01); <i>A61B</i>	5,716,397 A	2/1998	Myers
		<i>5/7435</i> (2013.01); <i>A61B 5/01</i> (2013.01); <i>A61B</i>	5,720,726 A	2/1998	Marcadis et al.
		<i>5/0422</i> (2013.01); <i>A61B 5/0538</i> (2013.01);	5,728,114 A	3/1998	Evans et al.
		<i>A61B 18/1492</i> (2013.01); <i>A61N 1/362</i>	5,730,127 A	3/1998	Avitall
		(2013.01); <i>A61B 2018/00267</i> (2013.01); <i>A61B</i>	5,762,066 A	6/1998	Law et al.
		<i>2018/00357</i> (2013.01); <i>A61B 2018/00577</i>	5,769,846 A	6/1998	Edwards et al.
		(2013.01); <i>A61B 2018/00797</i> (2013.01); <i>A61B</i>	5,782,239 A	7/1998	Webster, Jr.
		<i>2018/00839</i> (2013.01); <i>A61B 2018/00875</i>	5,782,879 A	7/1998	Rosborough et al.
		(2013.01); <i>A61B 2018/00892</i> (2013.01)	5,800,495 A	9/1998	Machek et al.
(56)	References Cited		5,824,066 A	10/1998	Gross
	U.S. PATENT DOCUMENTS		5,836,990 A	11/1998	Li
			5,876,343 A	3/1999	Teo
			5,881,727 A	3/1999	Edwards
			5,891,136 A	4/1999	McGee et al.
			5,904,711 A	5/1999	Flom et al.
			5,916,163 A	6/1999	Panescu et al.
			5,919,207 A	7/1999	Taheri
			5,921,924 A	7/1999	Avitall
			5,935,075 A	8/1999	Casscells et al.
			5,935,079 A	8/1999	Swanson et al.
			5,941,251 A	8/1999	Panescu et al.
			5,961,440 A	10/1999	Schweich, Jr. et al.
			5,968,040 A	10/1999	Swanson et al.
			5,984,950 A	11/1999	Cragg et al.
			6,001,069 A	12/1999	Tachibana et al.
			6,014,581 A	1/2000	Whayne et al.
			6,104,944 A	8/2000	Martinelli
			6,138,043 A	10/2000	Avitall
			6,142,993 A	11/2000	Whayne et al.
			6,156,046 A	12/2000	Passafaro et al.
			6,210,432 B1	4/2001	Solem et al.
			6,216,043 B1	4/2001	Swanson et al.
			6,217,573 B1	4/2001	Webster
			6,241,747 B1	6/2001	Ruff
			6,248,124 B1	6/2001	Pedros et al.
			6,258,258 B1	7/2001	Sartori et al.
			6,266,550 B1	7/2001	Selmon et al.
			6,304,769 B1	10/2001	Arenson et al.
			6,306,135 B1	10/2001	Ellman et al.
			6,308,091 B1	10/2001	Avitall
			6,319,249 B1	11/2001	Töllner
			6,346,105 B1	2/2002	Tu et al.
			6,350,263 B1	2/2002	Wetzig et al.
			6,358,258 B1	3/2002	Arcia et al.
			6,383,151 B1	5/2002	Diederich et al.
			6,389,311 B1	5/2002	Whayne et al.
			6,391,024 B1	5/2002	Sun et al.
			6,391,048 B1	5/2002	Ginn et al.
			6,391,054 B2	5/2002	Carpentier et al.
			6,402,781 B1	6/2002	Langberg et al.
			6,436,052 B1	8/2002	Nikolic et al.
			6,475,223 B1	11/2002	Werp et al.
			6,485,409 B1	11/2002	Voloshin et al.
			6,485,489 B2	11/2002	Teirstein et al.
			6,506,210 B1	1/2003	Kanner
			6,514,249 B1	2/2003	Maguire et al.
			6,529,756 B1	3/2003	Phan et al.
			6,537,198 B1	3/2003	Vidlund et al.
			6,537,314 B2	3/2003	Langberg et al.
			6,540,670 B1	4/2003	Hirata et al.
			6,551,312 B2	4/2003	Zhang et al.
			6,569,160 B1	5/2003	Goldin et al.
			6,569,198 B1	5/2003	Wilson et al.
			6,575,971 B2	6/2003	Hauck et al.
			6,589,208 B2	7/2003	Ewers et al.
			6,626,930 B1	9/2003	Allen et al.
			6,632,238 B2	10/2003	Ginn et al.
			6,635,056 B2	10/2003	Kadhiresan et al.
			6,640,119 B1	10/2003	Budd et al.
			6,662,034 B2	12/2003	Segner et al.

(56)

References Cited

U.S. PATENT DOCUMENTS

6,704,590	B2	3/2004	Haldeman	2003/0078671	A1	4/2003	Lesniak et al.
6,723,038	B1	4/2004	Schroeder et al.	2003/0105384	A1	6/2003	Sharkey et al.
6,726,716	B2	4/2004	Marquez	2003/0105520	A1	6/2003	Alferness et al.
6,760,616	B2	7/2004	Hoey et al.	2003/0109770	A1	6/2003	Sharkey et al.
6,780,197	B2	8/2004	Roe et al.	2003/0181819	A1	9/2003	Desai
6,788,969	B2	9/2004	Dupree et al.	2003/0229395	A1	12/2003	Cox
6,797,001	B2	9/2004	Mathis et al.	2004/0002626	A1	1/2004	Feld et al.
6,800,090	B2	10/2004	Alferness et al.	2004/0054279	A1	3/2004	Hanley
6,837,886	B2	1/2005	Collins et al.	2004/0133273	A1	7/2004	Cox
6,852,076	B2	2/2005	Nikolic et al.	2004/0138744	A1	7/2004	Lashinski et al.
6,855,143	B2	2/2005	Davison et al.	2004/0153146	A1	8/2004	Lashinski et al.
6,890,353	B2	5/2005	Cohn et al.	2004/0158321	A1	8/2004	Reuter et al.
6,892,091	B1	5/2005	Ben-Haim et al.	2004/0176797	A1	9/2004	Opolski
6,899,674	B2	5/2005	Viebach et al.	2004/0186566	A1	9/2004	Hindrichs et al.
6,907,297	B2	6/2005	Wellman et al.	2004/0215232	A1	10/2004	Belhe et al.
6,908,478	B2	6/2005	Alferness et al.	2004/0243170	A1	12/2004	Suresh et al.
6,913,576	B2	7/2005	Bowman	2004/0249408	A1	12/2004	Murphy et al.
6,918,903	B2	7/2005	Bass	2004/0249453	A1	12/2004	Cartledge et al.
6,926,669	B1	8/2005	Stewart et al.	2004/0267358	A1	12/2004	Reitan
6,942,657	B2	9/2005	Sinofsky et al.	2005/0004668	A1	1/2005	Aklog et al.
6,949,122	B2	9/2005	Adams et al.	2005/0015109	A1	1/2005	Lichtenstein
6,960,229	B2	11/2005	Mathis et al.	2005/0054938	A1	3/2005	Wehman et al.
6,986,775	B2	1/2006	Morales et al.	2005/0055089	A1	3/2005	Macoviak et al.
6,989,010	B2	1/2006	Francischelli et al.	2005/0060030	A1	3/2005	Lashinski et al.
6,989,028	B2	1/2006	Lashinski et al.	2005/0064665	A1	3/2005	Han
6,994,093	B2	2/2006	Murphy et al.	2005/0065420	A1	3/2005	Collins et al.
6,997,951	B2	2/2006	Solem et al.	2005/0065504	A1	3/2005	Melsky et al.
7,001,383	B2	2/2006	Keidar	2005/0080402	A1	4/2005	Santamore et al.
7,025,776	B1	4/2006	Houser et al.	2005/0096047	A1	5/2005	Haberman et al.
7,048,734	B1	5/2006	Fleischman et al.	2005/0096647	A1	5/2005	Steinke et al.
7,050,848	B2	5/2006	Hoey et al.	2005/0107723	A1	5/2005	Wehman et al.
7,052,487	B2	5/2006	Cohn et al.	2005/0107871	A1	5/2005	Realyvasquez et al.
7,068,867	B2	6/2006	Adoram et al.	2005/0125030	A1	6/2005	Forsberg et al.
7,141,019	B2	11/2006	Pearlman	2005/0148892	A1	7/2005	Desai
7,144,363	B2	12/2006	Pai et al.	2005/0149014	A1	7/2005	Hauck et al.
7,177,677	B2	2/2007	Kaula et al.	2005/0154252	A1	7/2005	Sharkey et al.
7,186,210	B2	3/2007	Feld et al.	2005/0182365	A1	8/2005	Hennemann
7,187,964	B2	3/2007	Khoury	2005/0187620	A1	8/2005	Pai
7,189,202	B2	3/2007	Lau et al.	2005/0197692	A1	9/2005	Pai
7,279,007	B2	10/2007	Nikolic et al.	2005/0197693	A1	9/2005	Pai et al.
7,300,435	B2	11/2007	Wham et al.	2005/0197694	A1	9/2005	Pai et al.
7,303,526	B2	12/2007	Sharkey et al.	2005/0203558	A1	9/2005	Maschke
7,335,196	B2	2/2008	Swanson et al.	2005/0209636	A1	9/2005	Widomski et al.
7,507,252	B2	3/2009	Lashinski et al.	2005/0216054	A1	9/2005	Widomski et al.
7,530,980	B2	5/2009	Hooven	2005/0240249	A1	10/2005	Tu et al.
7,738,967	B2	6/2010	Salo	2005/0251116	A1	11/2005	Steinke et al.
8,103,338	B2	1/2012	Harlev et al.	2005/0251132	A1	11/2005	Oral et al.
8,150,499	B2	4/2012	Gelbart et al.	2005/0256521	A1	11/2005	Kozel
8,224,432	B2	7/2012	MacAdam et al.	2005/0267574	A1	12/2005	Cohn et al.
2001/0003158	A1	6/2001	Kensley et al.	2006/0009755	A1	1/2006	Sra
2001/0005787	A1	6/2001	Oz et al.	2006/0009756	A1	1/2006	Francischelli et al.
2001/0018611	A1	8/2001	Solem et al.	2006/0014998	A1	1/2006	Sharkey et al.
2001/0020126	A1	9/2001	Swanson et al.	2006/0015002	A1	1/2006	Moadddeb et al.
2002/0002329	A1	1/2002	Avitall	2006/0015003	A1	1/2006	Moaddes et al.
2002/0016628	A1	2/2002	Langberg et al.	2006/0015038	A1	1/2006	Weymarn-Scharli
2002/0087156	A1	7/2002	Maguire et al.	2006/0015096	A1	1/2006	Hauck et al.
2002/0087173	A1	7/2002	Alferness et al.	2006/0025800	A1	2/2006	Suresh
2002/0099415	A1	7/2002	Panescu et al.	2006/0030881	A1	2/2006	Sharkey et al.
2002/0107478	A1	8/2002	Wendlandt	2006/0085049	A1	4/2006	Cory et al.
2002/0107511	A1	8/2002	Collins et al.	2006/0089637	A1	4/2006	Werneth et al.
2002/0115941	A1	8/2002	Whayne et al.	2006/0135968	A1	6/2006	Schaller
2002/0115944	A1	8/2002	Mendes et al.	2006/0135970	A1	6/2006	Schaller
2002/0169504	A1	11/2002	Alferness et al.	2006/0184242	A1	8/2006	Lichtenstein
2002/0177782	A1	11/2002	Penner	2006/0199995	A1	9/2006	Vijay
2002/0183836	A1	12/2002	Liddicoat et al.	2006/0229491	A1	10/2006	Sharkey et al.
2002/0183841	A1	12/2002	Cohn et al.	2006/0235286	A1	10/2006	Stone et al.
2002/0188170	A1	12/2002	Santamore et al.	2006/0235314	A1	10/2006	Migliuolo et al.
2003/0028118	A1	2/2003	Dupree et al.	2006/0264980	A1	11/2006	Khairkhanan et al.
2003/0028183	A1	2/2003	Sanchez et al.	2006/0281965	A1	12/2006	Khairkhanan et al.
2003/0050685	A1	3/2003	Nikolic et al.	2006/0293698	A1	12/2006	Douk
2003/0055420	A1	3/2003	Kadhiresan et al.	2006/0293725	A1	12/2006	Rubinsky et al.
2003/0069570	A1	4/2003	Witzel et al.	2007/0016068	A1	1/2007	Grunwald et al.
2003/0069573	A1	4/2003	Kadhiresan et al.	2007/0038208	A1	2/2007	Kefer
2003/0069636	A1	4/2003	Solem et al.	2007/0083193	A1	4/2007	Werneth et al.
2003/0078465	A1	4/2003	Pai et al.	2007/0083195	A1	4/2007	Werneth et al.
				2007/0088362	A1	4/2007	Bonutti et al.
				2007/0115390	A1	5/2007	Makara et al.
				2007/0118215	A1	5/2007	Moadddeb
				2007/0129717	A1	6/2007	Brown, III et al.

(56)

References Cited

U.S. PATENT DOCUMENTS

2007/0161846	A1	7/2007	Nikolic et al.
2007/0198058	A1	8/2007	Gelbart et al.
2007/0213578	A1	9/2007	Khairkahan et al.
2007/0213815	A1	9/2007	Khairkahan et al.
2007/0249999	A1	10/2007	Sklar et al.
2007/0270688	A1	11/2007	Gelbart et al.
2007/0299343	A1	12/2007	Waters
2008/0004534	A1	1/2008	Gelbart et al.
2008/0004643	A1	1/2008	To et al.
2008/0004697	A1	1/2008	Lichtenstein et al.
2008/0045778	A1	2/2008	Lichtenstein et al.
2008/0071298	A1	3/2008	Khairkahan et al.
2008/0281322	A1	11/2008	Sherman et al.
2008/0312713	A1	12/2008	Wilfley et al.
2009/0018617	A1	1/2009	Skelton et al.
2009/0069704	A1	3/2009	MacAdam et al.
2009/0131930	A1	5/2009	Gelbart et al.
2009/0157058	A1	6/2009	Ferren et al.
2009/0192441	A1	7/2009	Gelbart et al.
2009/0287271	A1	11/2009	Blum et al.
2009/0287304	A1	11/2009	Dahlgren et al.
2010/0249771	A1	9/2010	Pearson et al.
2010/0268059	A1	10/2010	Ryu et al.
2011/0125172	A1	5/2011	Gelbart et al.
2013/0310702	A1	11/2013	Reinders et al.
2013/0310826	A1	11/2013	Goertzen et al.
2013/0310828	A1	11/2013	Reinders et al.

FOREIGN PATENT DOCUMENTS

WO	95/20349	A1	8/1995
WO	97/17892	A1	5/1997
WO	03/015611	A2	2/2003
WO	03/077800	A1	9/2003
WO	2004/012629	A1	2/2004
WO	2004/047679	A1	6/2004
WO	2004/084746	A2	10/2004
WO	2004/100803	A1	11/2004
WO	2005/070330	A1	8/2005
WO	2005/102181	A1	11/2005
WO	2006/017809	A2	2/2006
WO	2006/105121	A2	10/2006
WO	2006/135747	A2	12/2006
WO	2006/135749	A2	12/2006
WO	2007/021647	A2	2/2007
WO	2007/115390	A1	10/2007
WO	2008/002606	A2	1/2008
WO	2009/065042	A2	5/2009
WO	2012/100184	A2	7/2012
WO	2012/100185	A2	7/2012
WO	2013/176880	A1	11/2013
WO	2013/176881	A1	11/2013

OTHER PUBLICATIONS

International Search Report and Written Opinion mailed Sep. 17, 2013 issued in PCT/US2013/039982.

International Search Report and Written Opinion mailed Sep. 27, 2013 issued in PCT/US2013/039977.

Becker, et al., "Ablation of Atrial Fibrillation: Energy Sources and Navigation Tools: A Review", *Journal of Electrocardiology*, vol. 37, Supplement 2004, pp. 55-62.

Buchbinder, Maurice, "Dynamic Mitral Valve Annuloplasty: A Reshapable Ring for Residual and Recurring MR", *Foundation for Cardiovascular Medicine*, May 24, 2007.

Calkins, Hugh, "Electrophysiology: Radiofrequency Catheter Ablation of Supraventricular Arrhythmias", *Heart*, 2001; 85; pp. 594-600.

De Ponti, et al., "Non-Fluoroscopic Mapping Systems for

Electrophysiology: the Tool or Toy Dilemma After 10 Years", *European Heart Journal*, 2006; 27, pp. 1134-1136.

Gabriel, et al., "The Dielectric Properties of Biological Tissues: I. Literature Survey", *Phys. Med. Biol.*; 41, 1996, pp. 2231-2249.

Konings, et al., "Development of an Intravascular Impedance Catheter for Detection of Fatty Lesions in Arteries", *IEEE Transactions on Medical Imaging*, vol. 16, No. 4, Aug. 1997, pp. 439-446.

Mack, Michael J., "New Techniques for Percutaneous Repair of the Mitral Valve", *Heart Fail Rev*, 2006; 11, pp. 259-268.

Otasevic, et al., "First-in-Man Implantation of Left Ventricular Partitioning Device in a Patient With Chronic Heart Failure: Twelve-Month Follow-Up", *Journal of Cardiac Failure*, vol. 13, No. 7, 2007, pp. 517-520.

Sharkey, et al., "Left Ventricular Apex Occluder. Description of a Ventricular Partitioning Device", *EuroIntervention*, 2006, pp. 125-127.

Stiles, et al., "Simulated Characterization of Atherosclerotic Lesions in the Coronary Arteries by Measurement of Bioimpedance", *IEEE Transactions on Biomedical Engineering*, vol. 50, No. 7, Jul. 2003, pp. 916-921.

Tanaka, et al., "Artificial SMA Valve for Treatment of Urinary Incontinence: Upgrading of Valve and Introduction of Transcutaneous Transformer", *Bio-Medical Materials and Engineering*; vol. 9, 1999, pp. 97-112.

Timek, et al., "Septal-Lateral Annular Cinching Abolishes Acute Ischemic Mitral Regurgitation", *Journal of Thoracic and Cardiovascular Surgery*, vol. 123, No. 5, May 2002, pp. 881-888.

Timek, et al., "Septal-Lateral Annular Cinching (SLAC) Reduces Mitral Annular Size Without Perturbing Normal Annular Dynamics", *Journal of Heart Valve Disease*, vol. 11, No. 1, Jan. 2002.

Valvano, et al., "Thermal Conductivity and Diffusivity of Biomaterials Measured with Self-Heated Thermistors", *International Journal of Thermophysics*, vol. 6, No. 3, 1985, pp. 301-311.

Prosecution Documents for U.S. Appl. No. 11/436,584, now abandoned.

Prosecution Documents for U.S. Appl. No. 11/941,819, now published as US 2009-0131930 A1.

Prosecution Documents for U.S. Appl. No. 12/010,458, now published as US 2009-0192441 A1.

Prosecution Documents for U.S. Appl. No. 12/950,871, now patented as US 8,150,499.

Specification and Drawings of U.S. Appl. No. 10/690,131.

International Search Report, mailed Dec. 5, 2007 for PCT/US2007/014902, 5 pages.

International Search Report, mailed Dec. 2, 2009 for PCT/US2008/083644, 5 pages.

International Preliminary Report on Patentability, issued Jan. 6, 2009 for PCT/US2007/014902, 8 pages.

Written Opinion, mailed Dec. 5, 2007, for PCT/US2007/014902, 7 pages.

Written Opinion, mailed Dec. 2, 2009, for PCT/US2008/083644, 9 pages.

Ensite System Instructions for use, 54-06154-001 Rev02, Chapter 7 Waveforms and Segments, pp. 85-90.

"Waveforms and Segments", Ensite System Instructions for use, 54-06154-001 Rev02, Chapter 7, pp. 85-90 © 2007 St. Jude Medical.

Reinders et al., "Systems and Methods for Activating Transducers", Response to Restriction Requirement, filed Dec. 23, 2014 for U.S. Appl. No. 13/792,781, 15 pages.

Reinders et al., "Systems and Methods for Activating Transducers", Response to Restriction Requirement, filed Dec. 23, 2014 for U.S. Appl. No. 13/792,945, 16 pages.

Reinders et al., "Systems and Methods for Activating Transducers", Notice of Allowance for U.S. Appl. No. 13/792,945 mailed Jan. 27, 2015, 49 pages.

Reinders et al., "Systems and Methods for Activating Transducers", Notice of Allowance mailed Feb. 3, 2015 for U.S. Appl. No. 13/792,781, 52 pages.

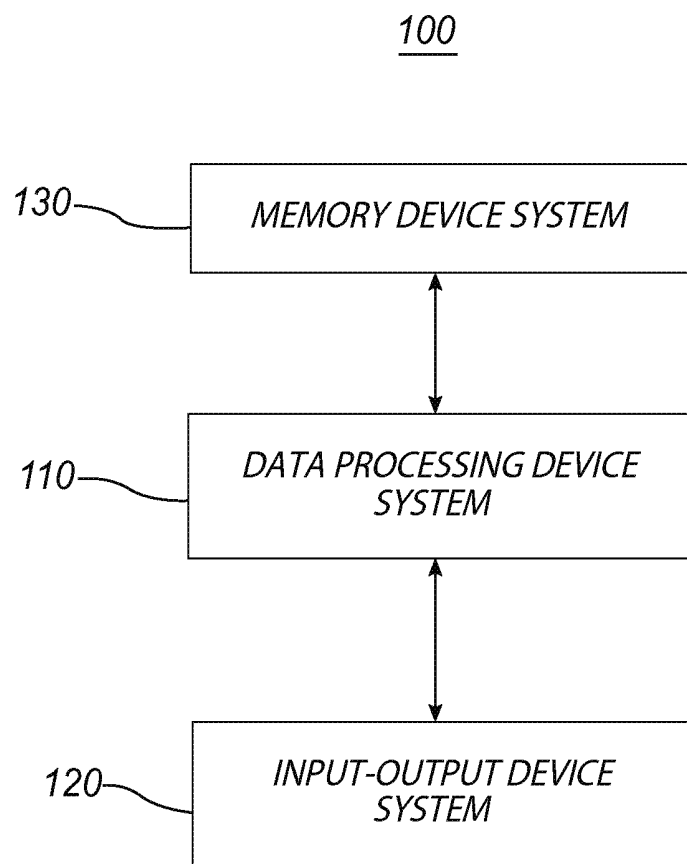

FIG. 1

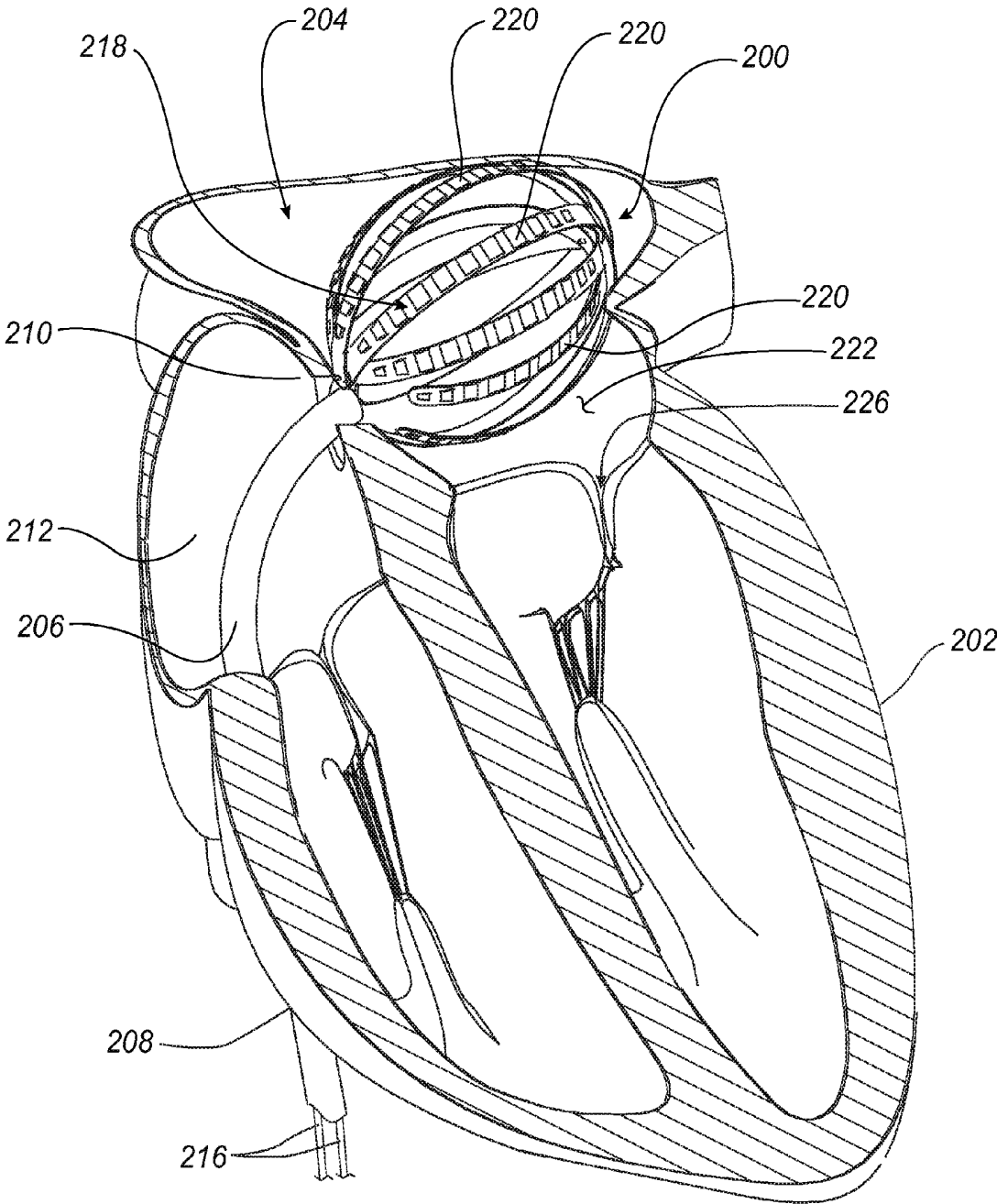

FIG. 2

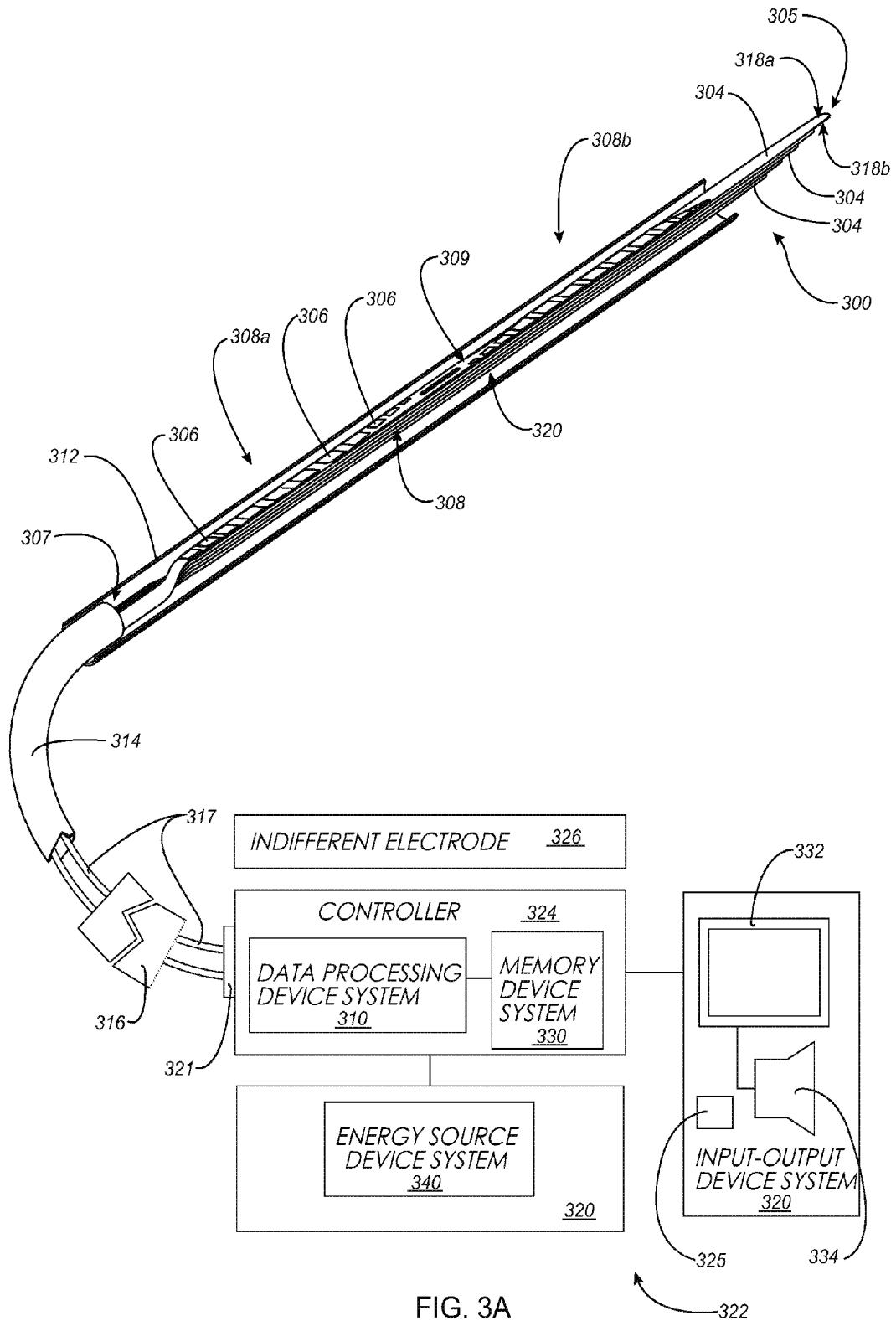

FIG. 3A

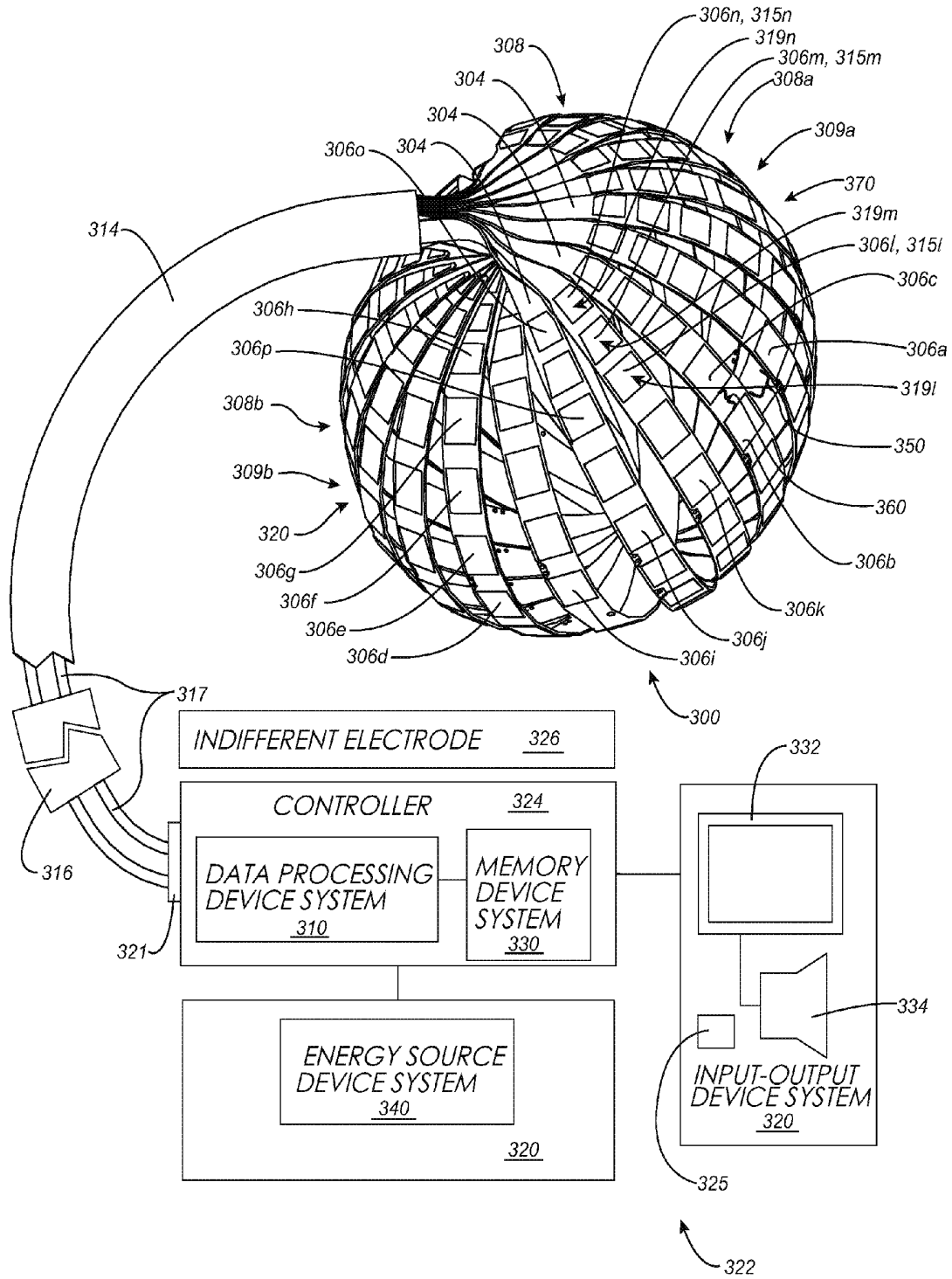

FIG. 3B

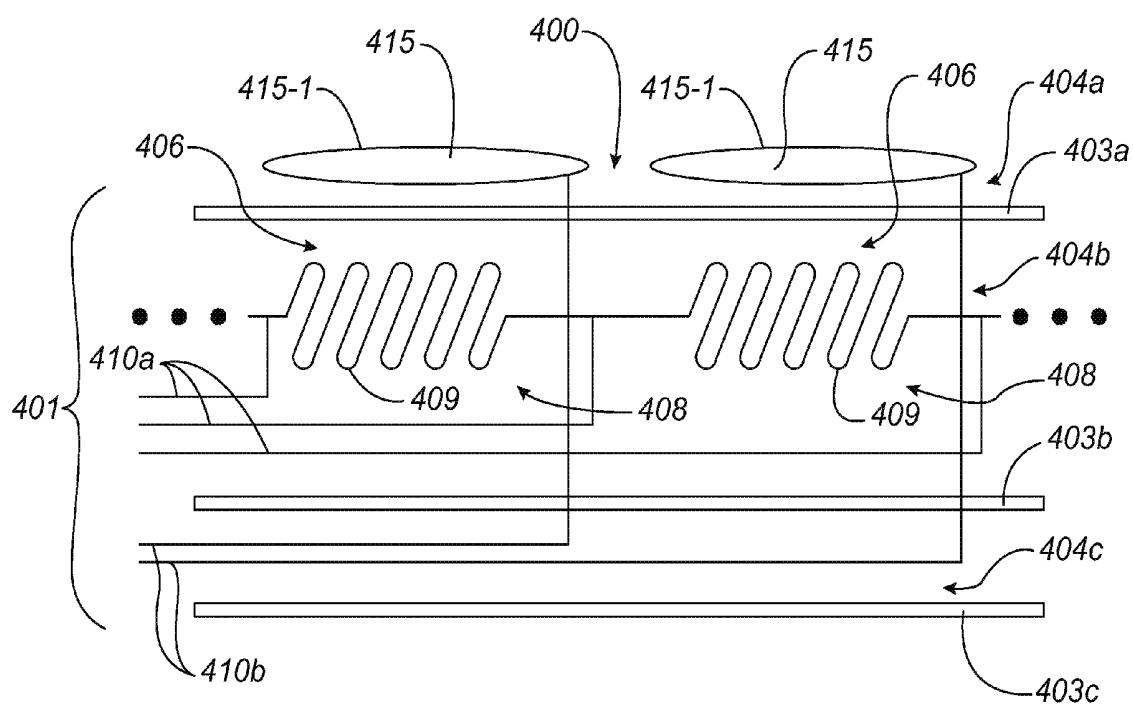

FIG. 4

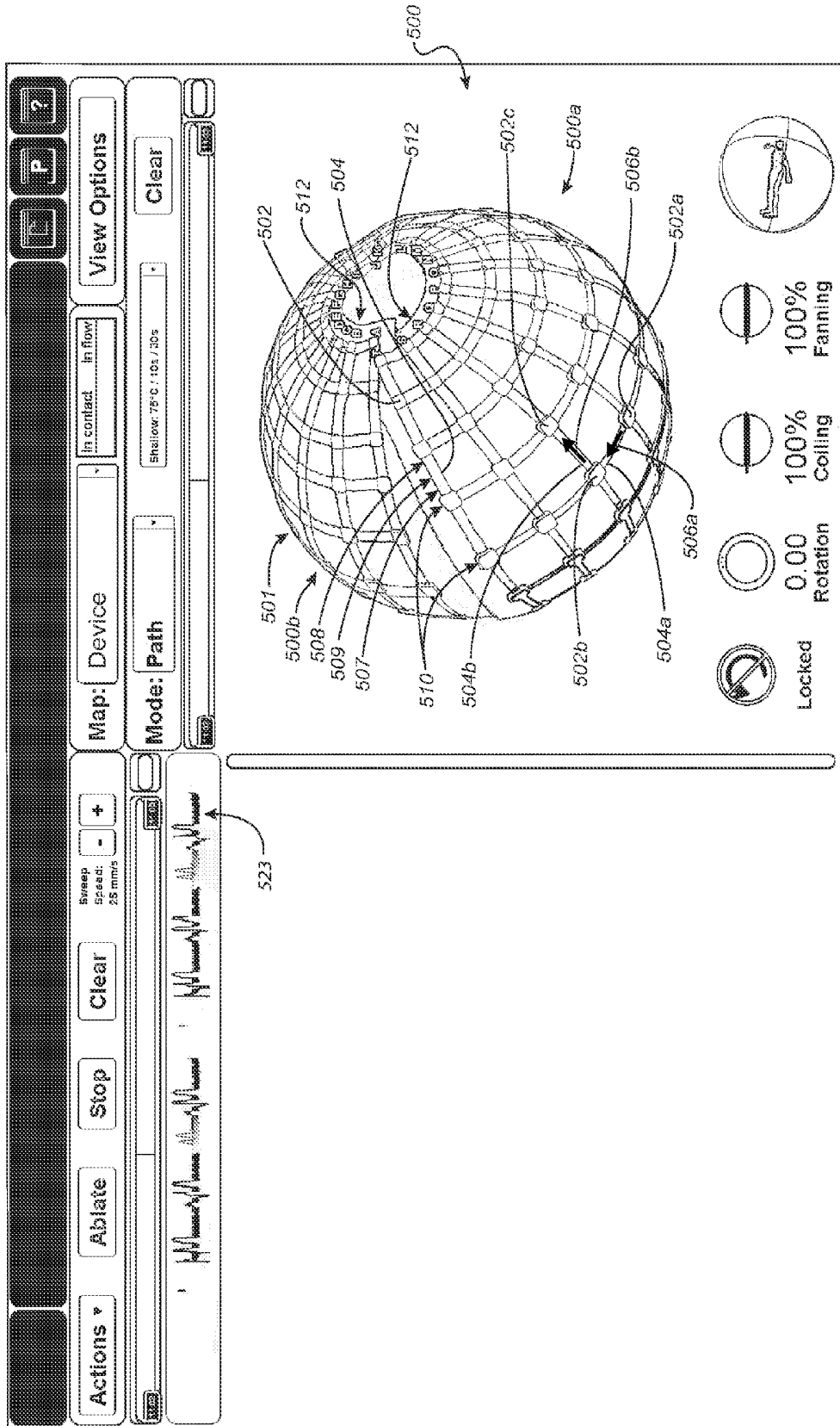

FIG. 5A

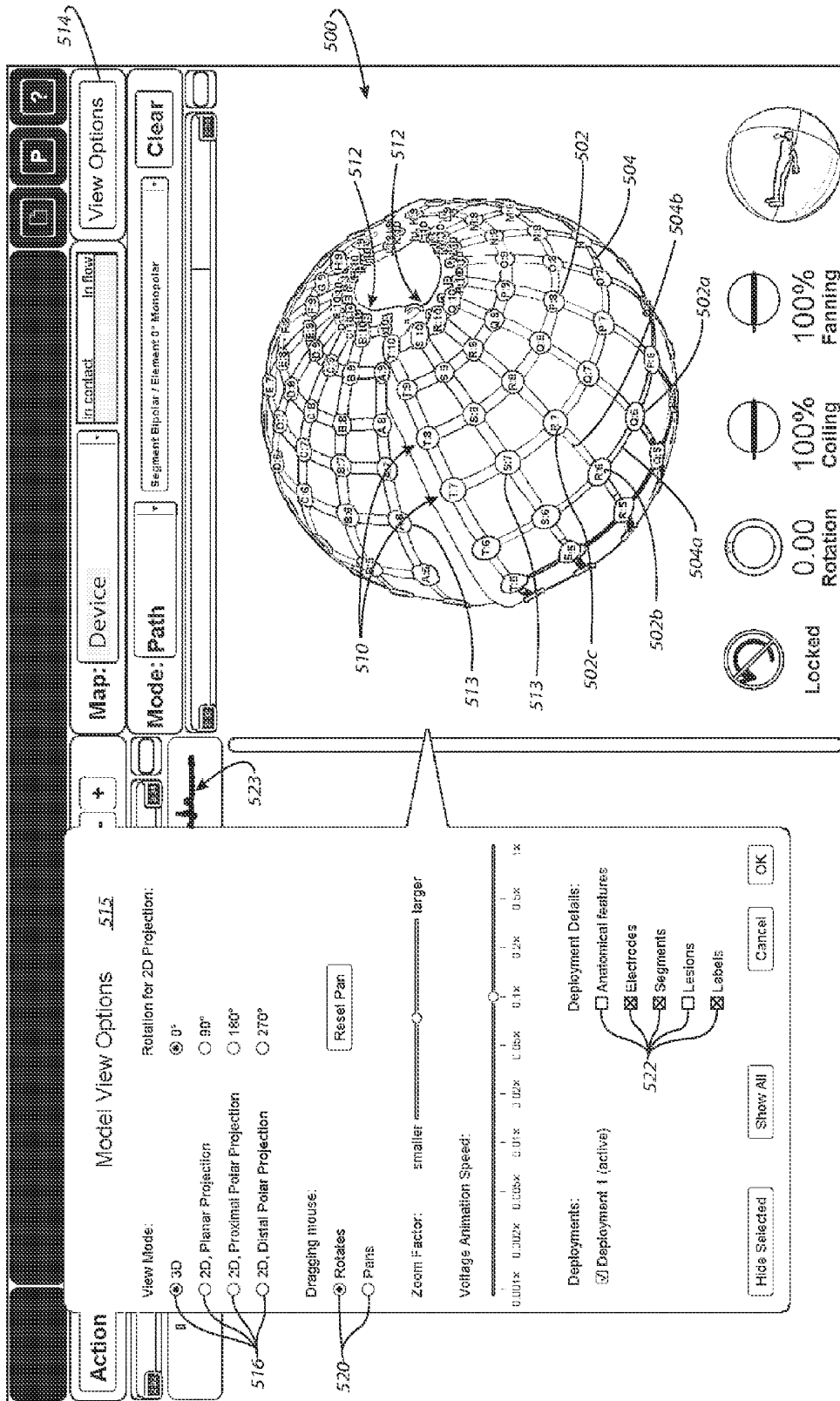

FIG. 5B

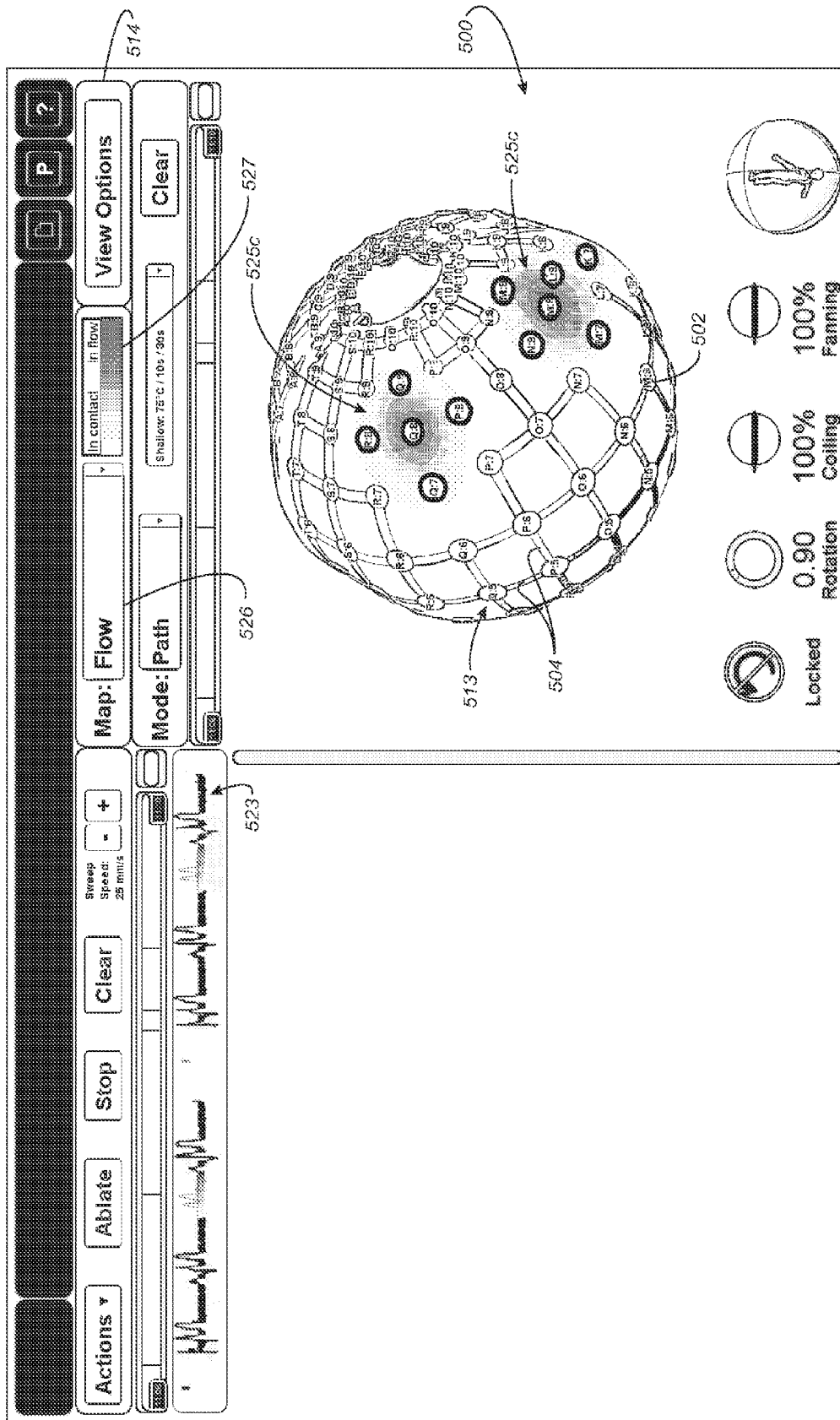

FIG. 5C

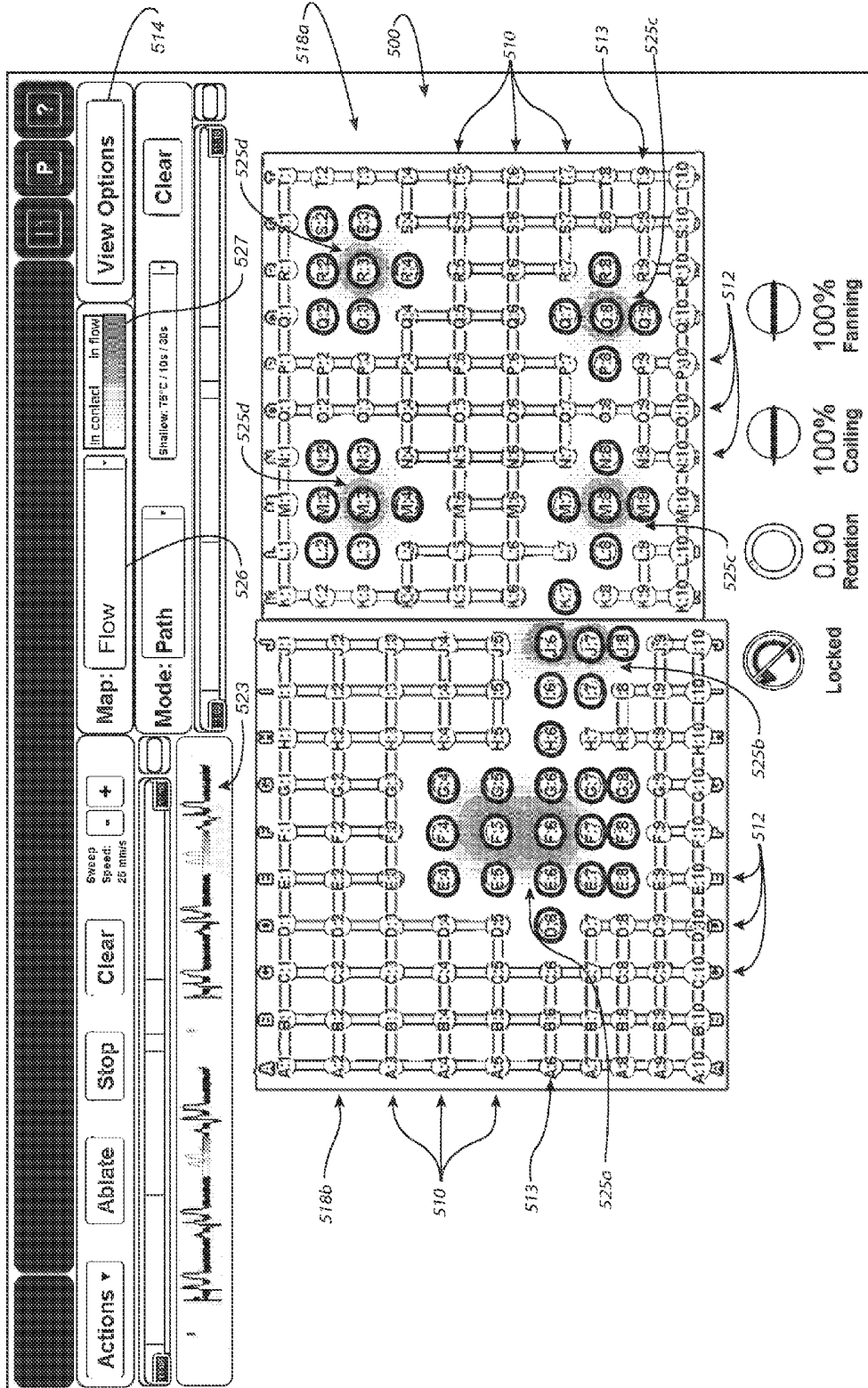

FIG. 5D

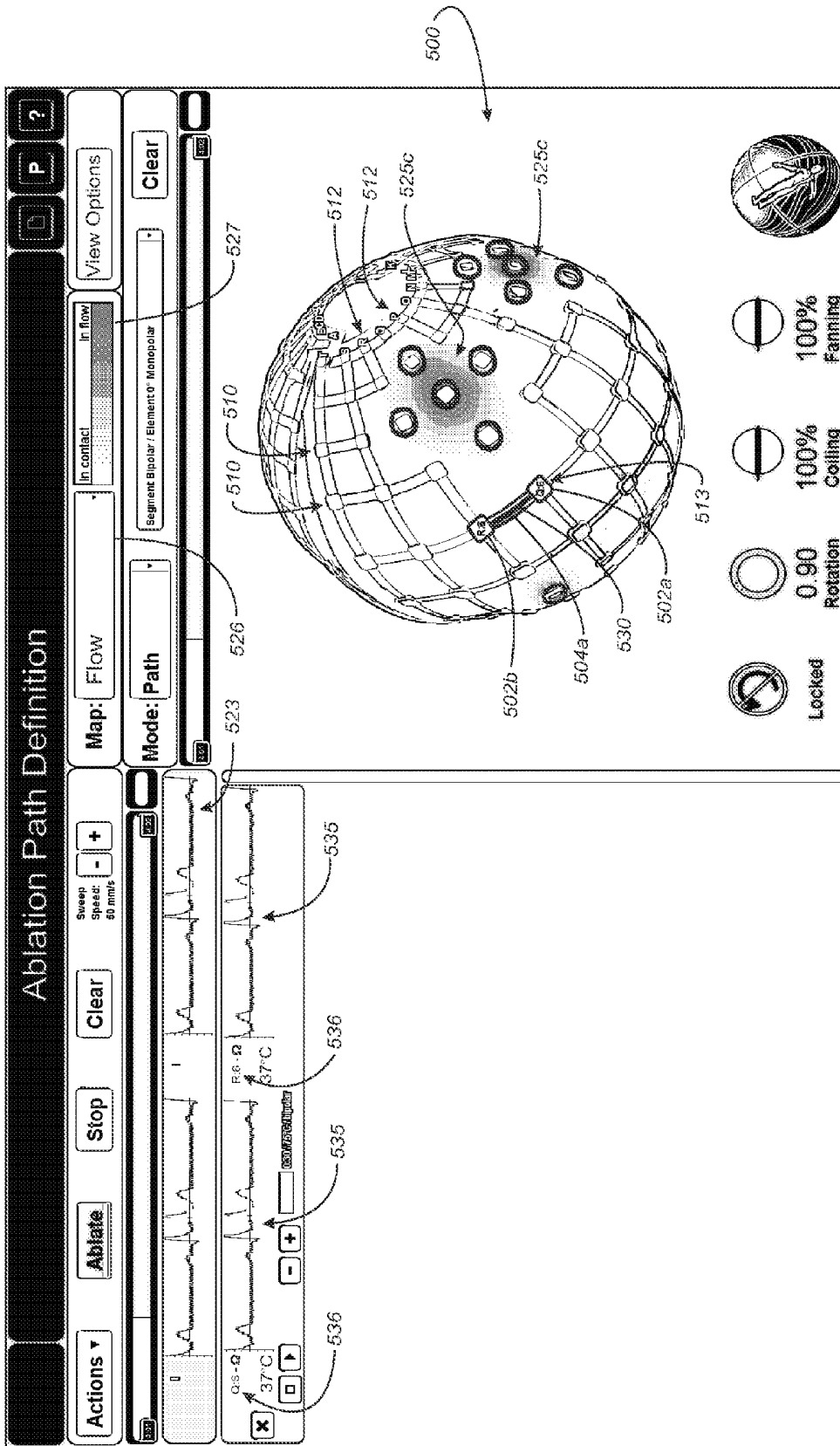

FIG. 5E

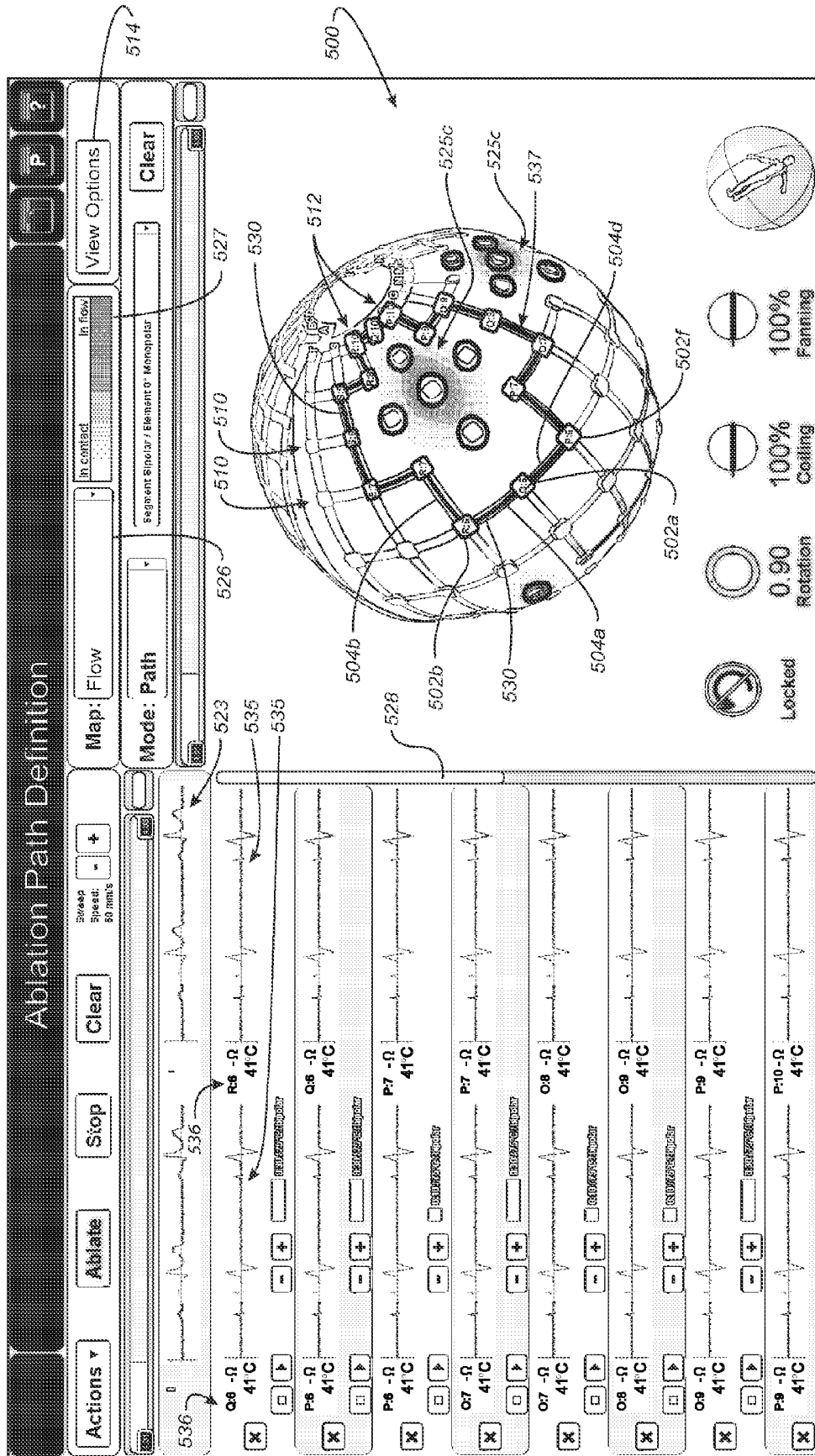

FIG. 5F

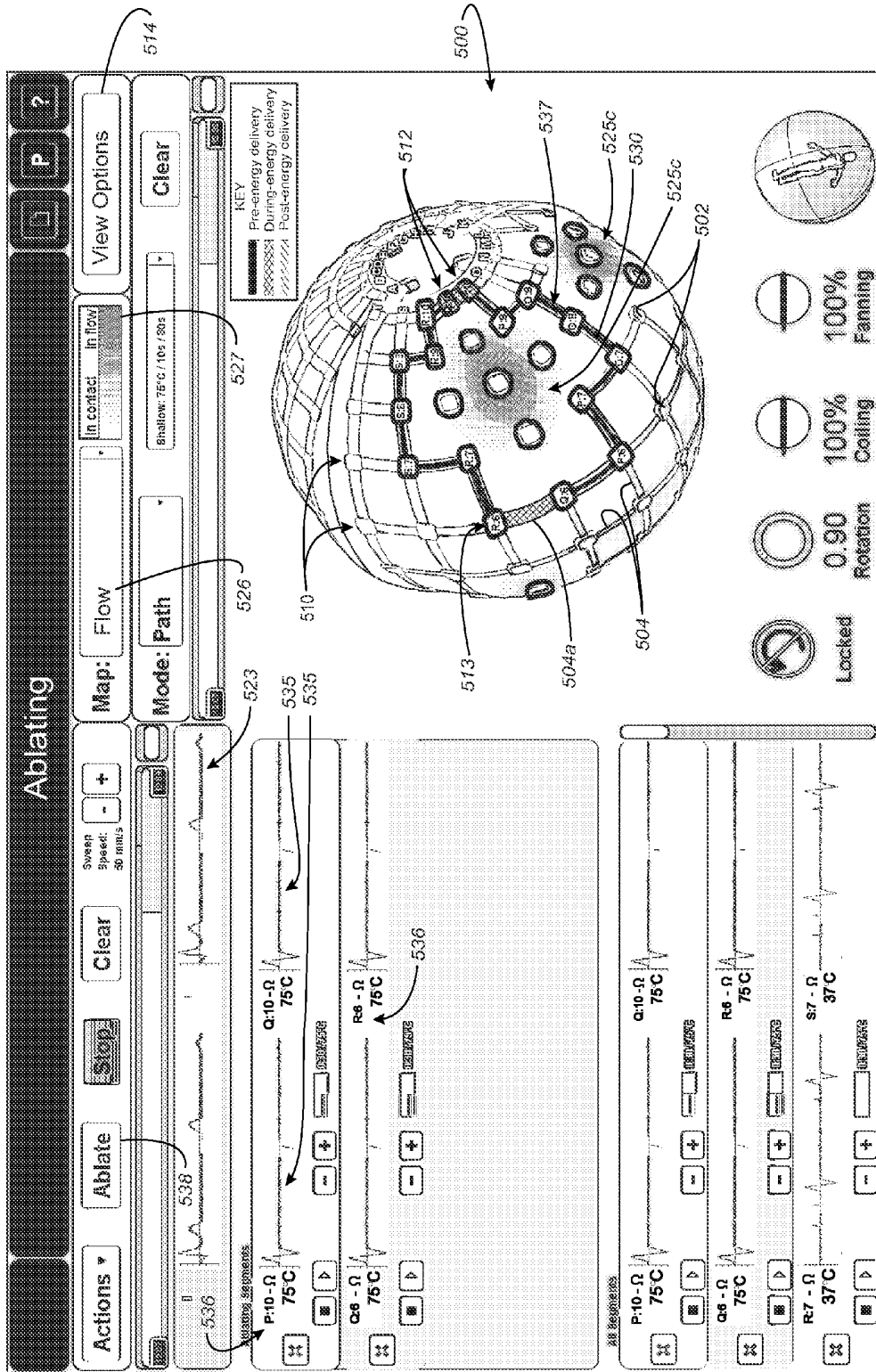

FIG. 5G

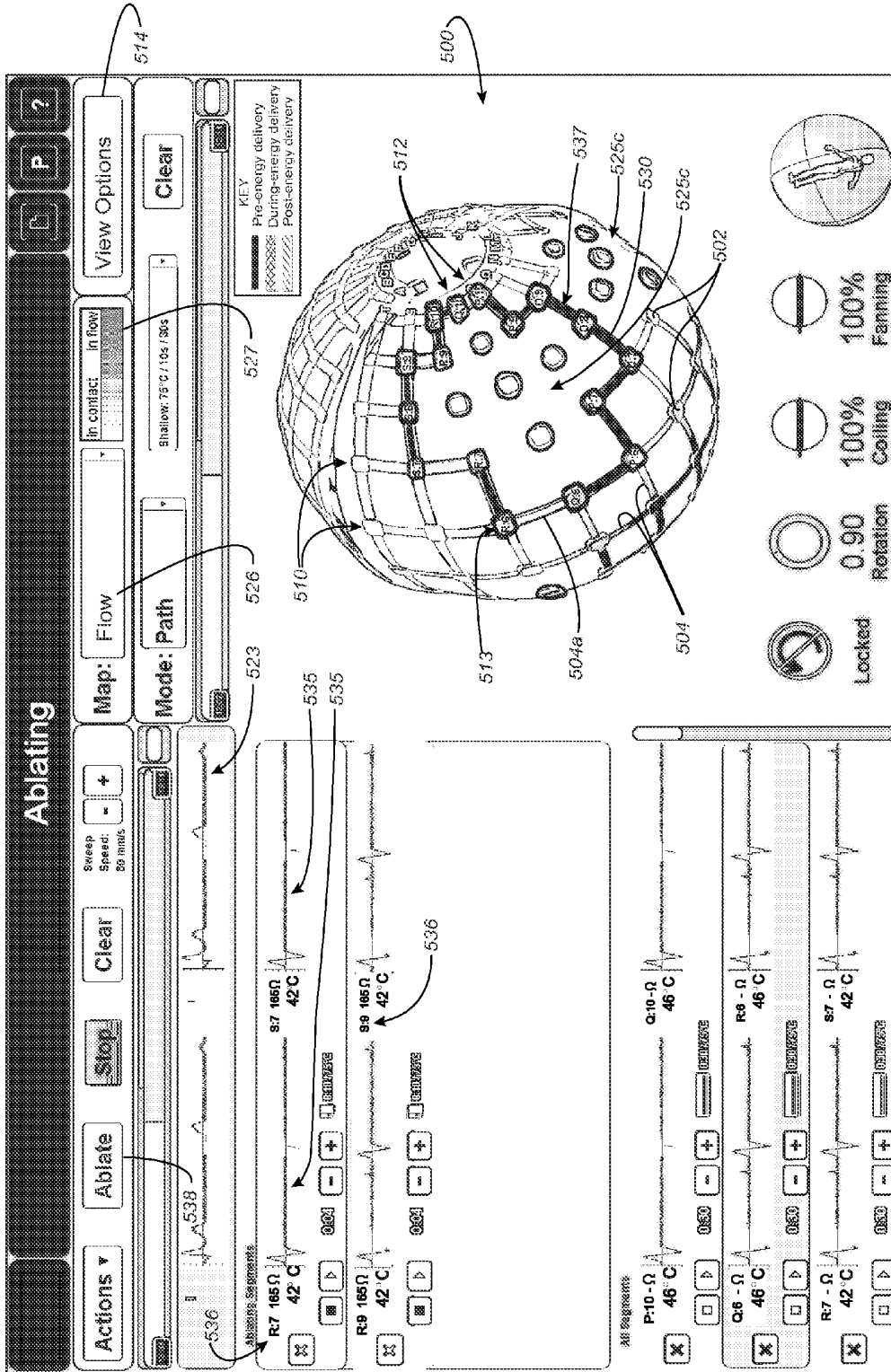
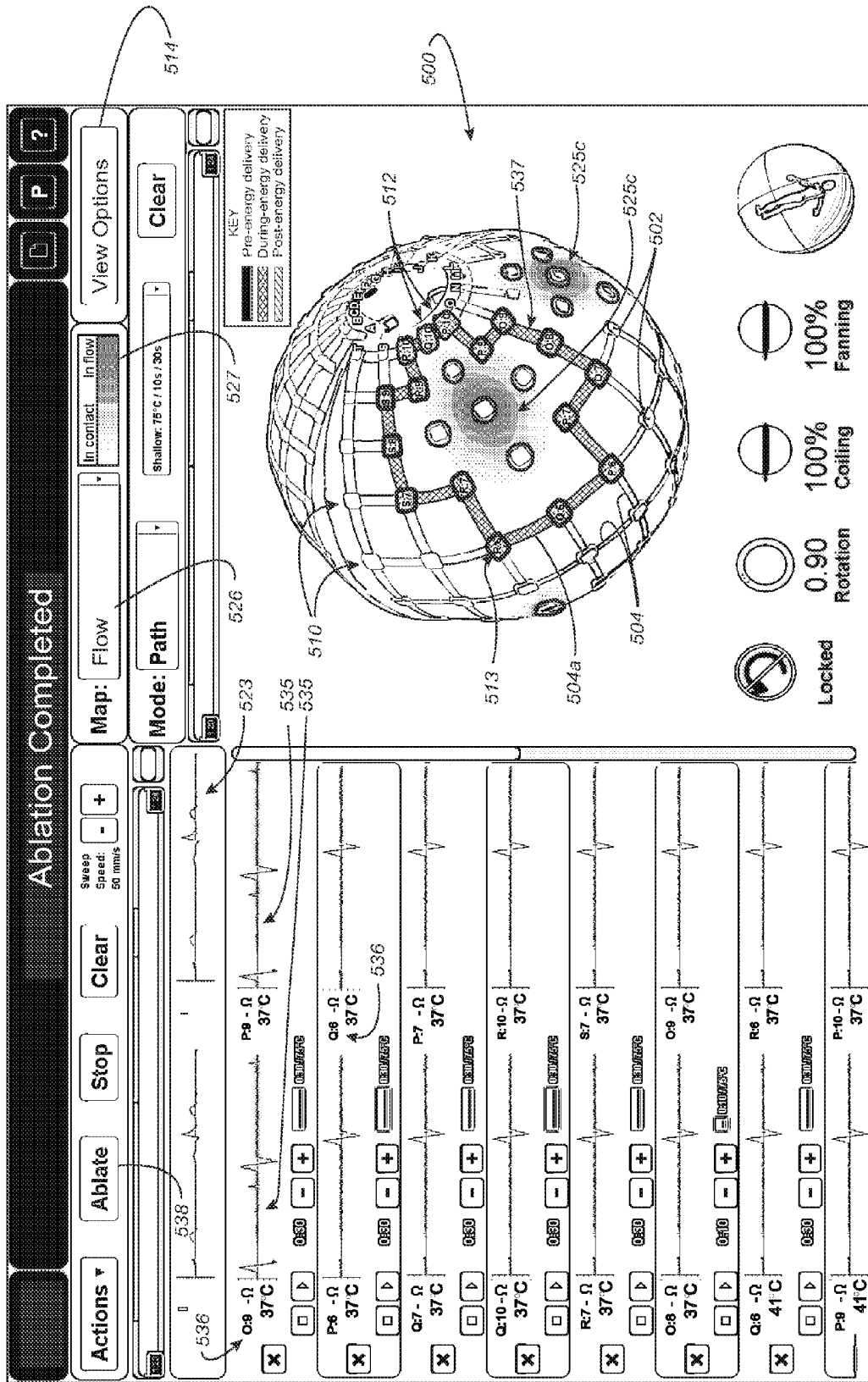

FIG. 5H



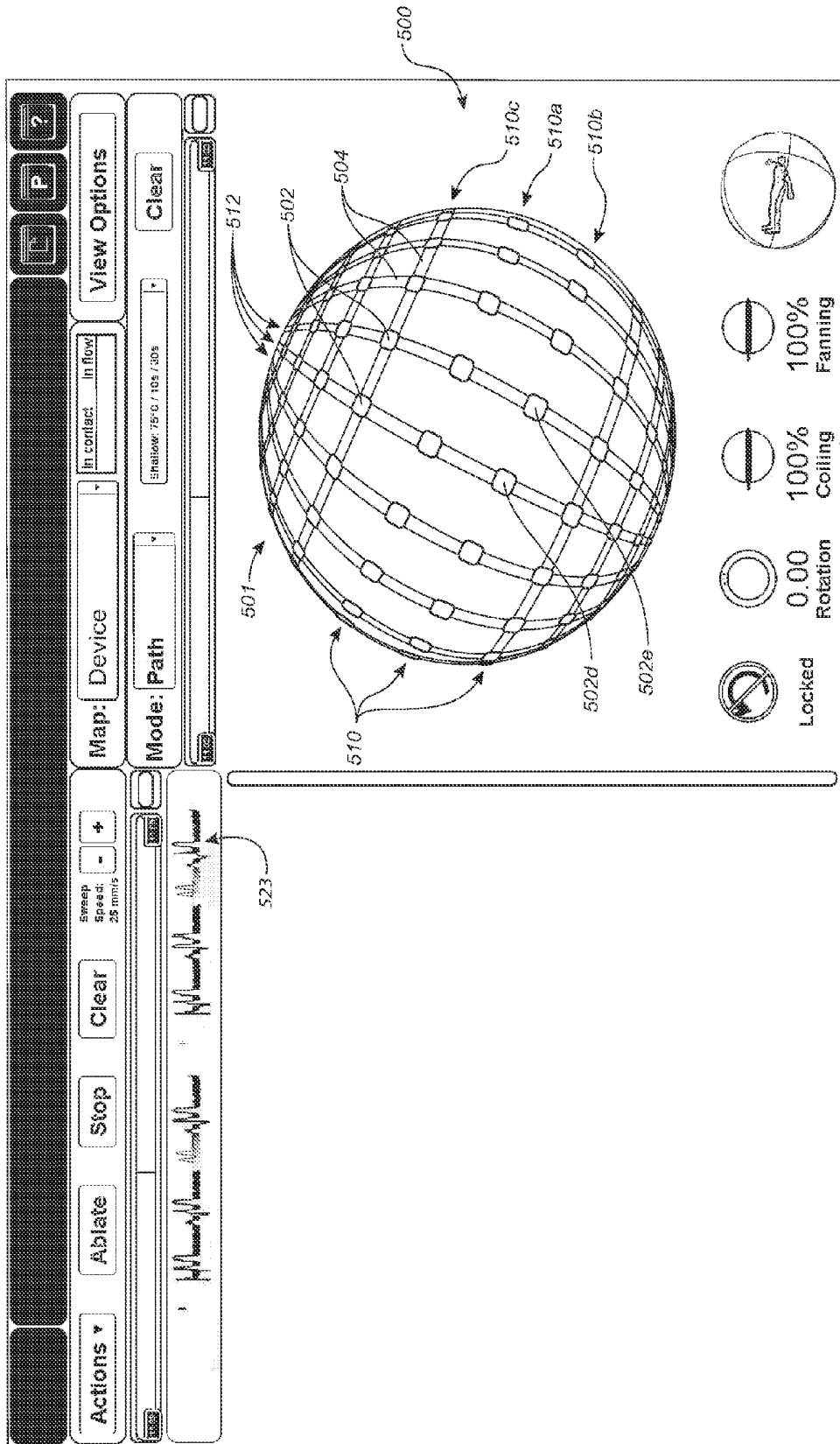

FIG. 5J

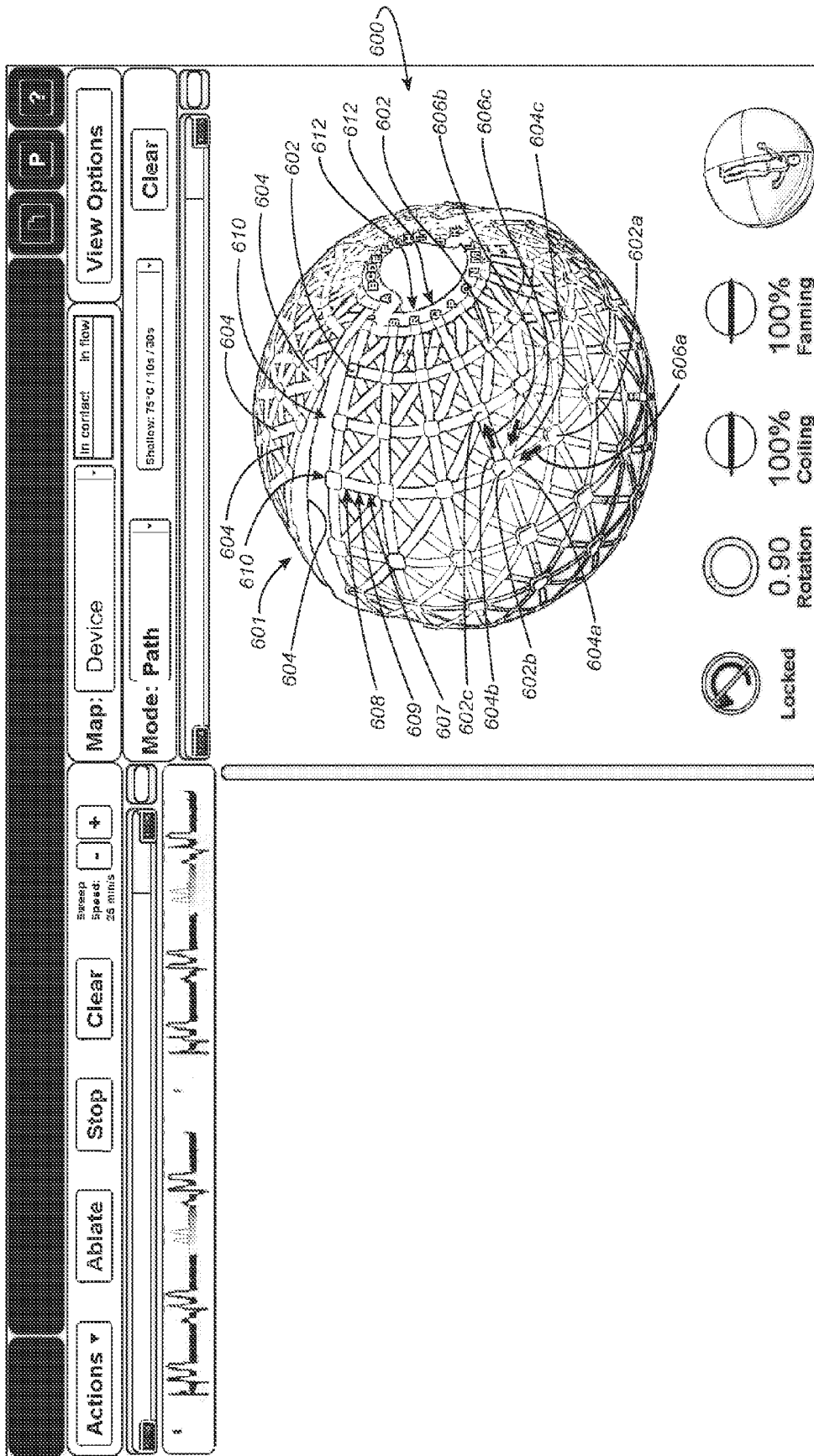

FIG. 6

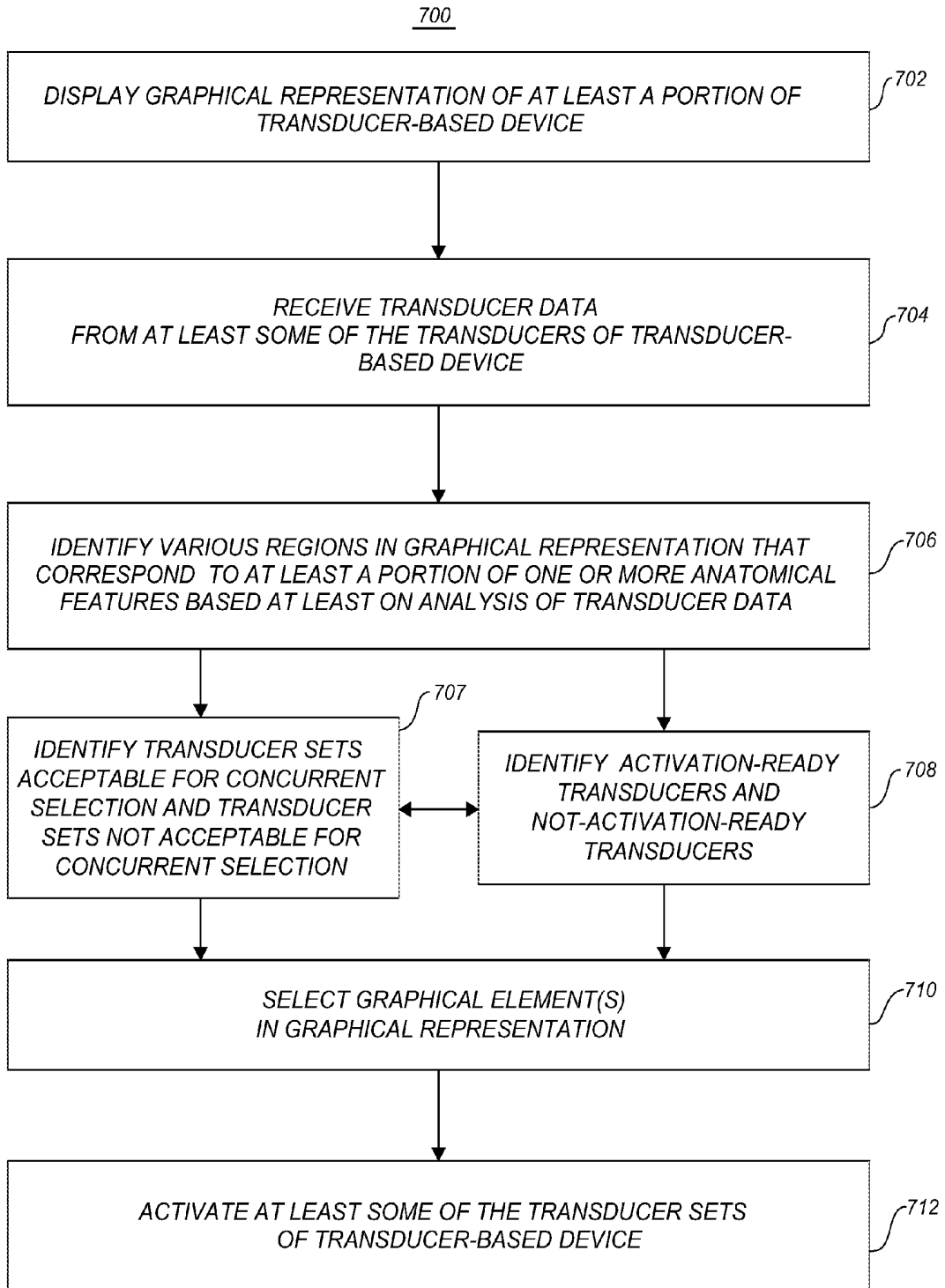

FIG. 7A

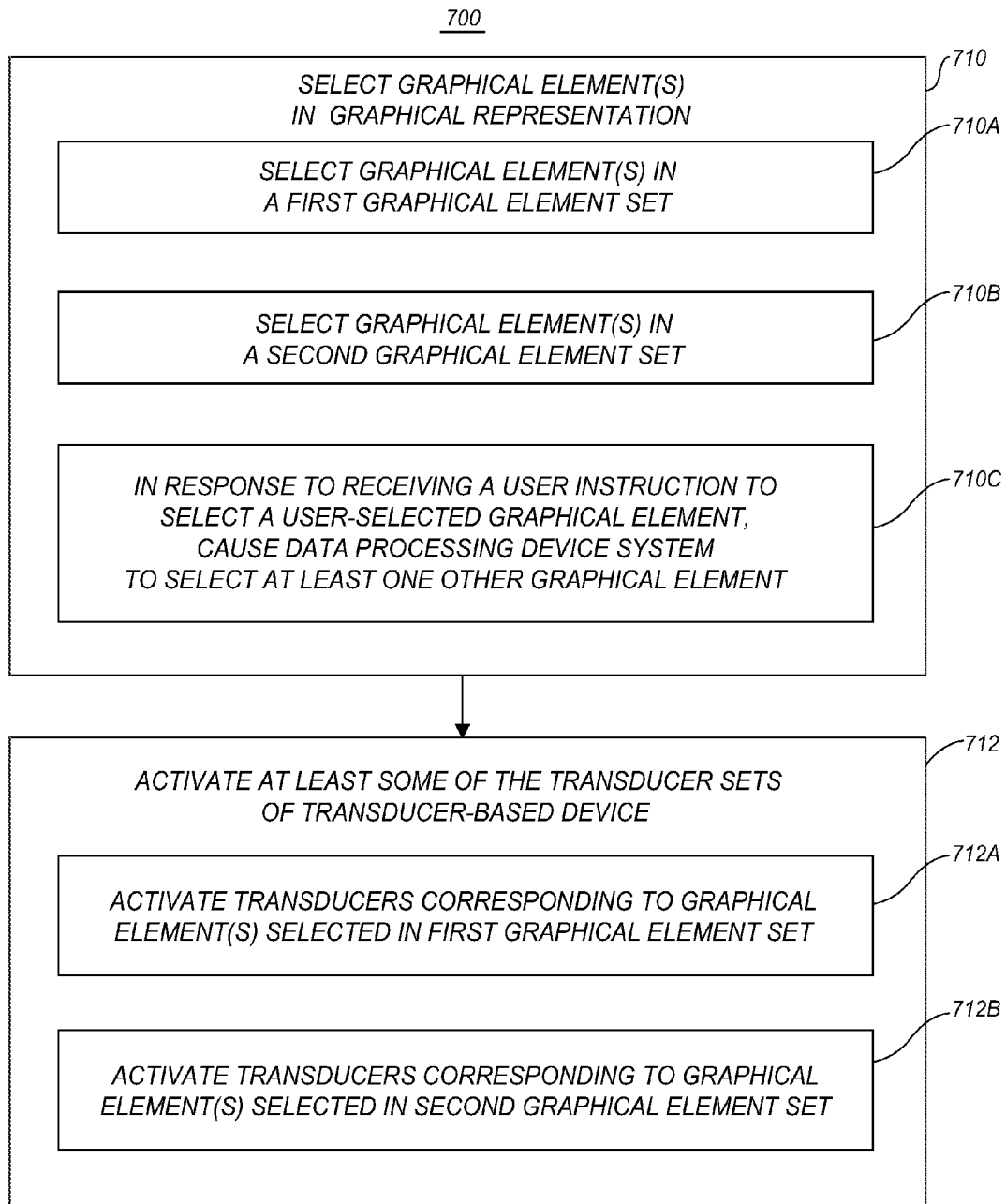

FIG. 7B

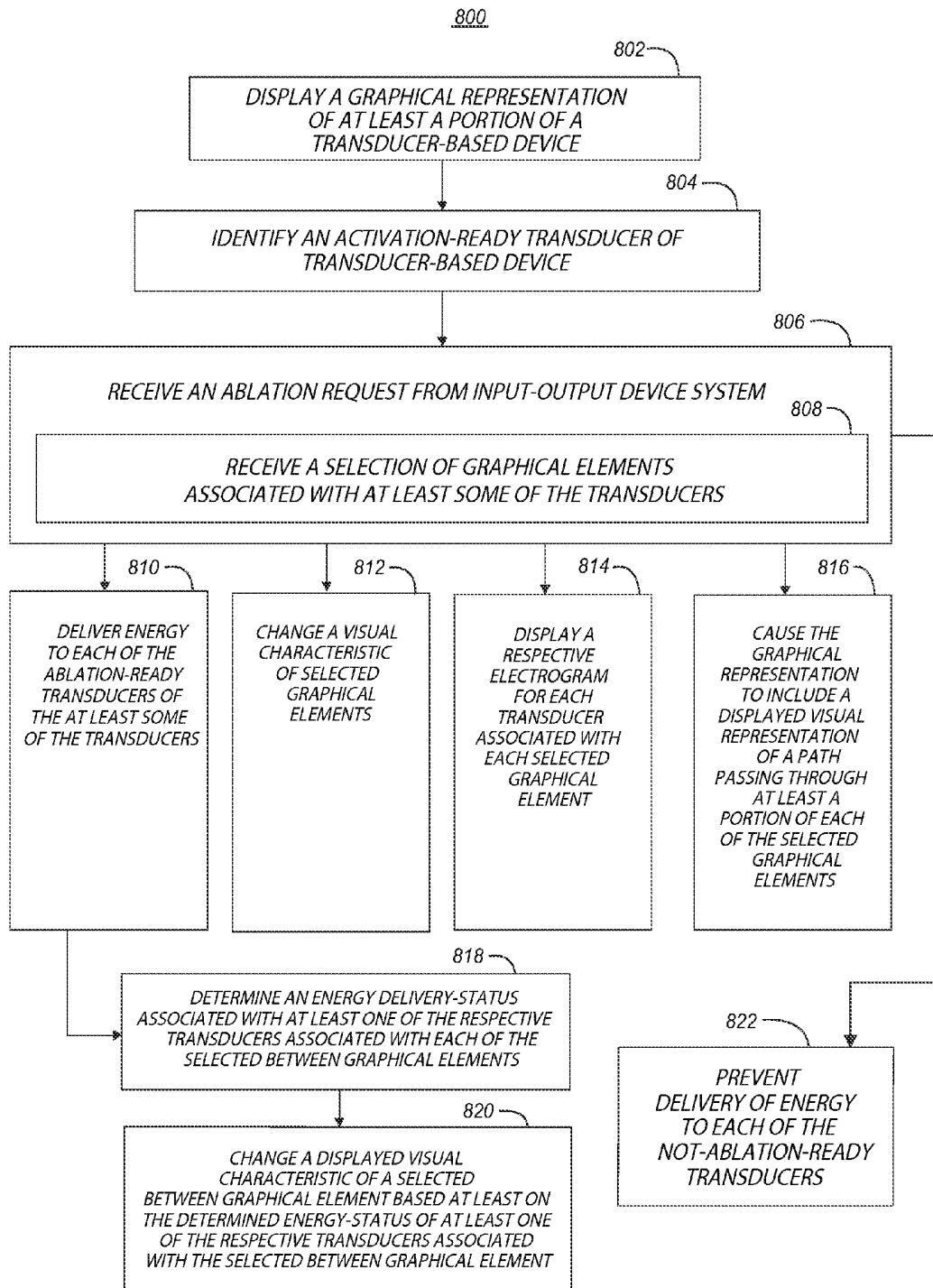

FIG. 8

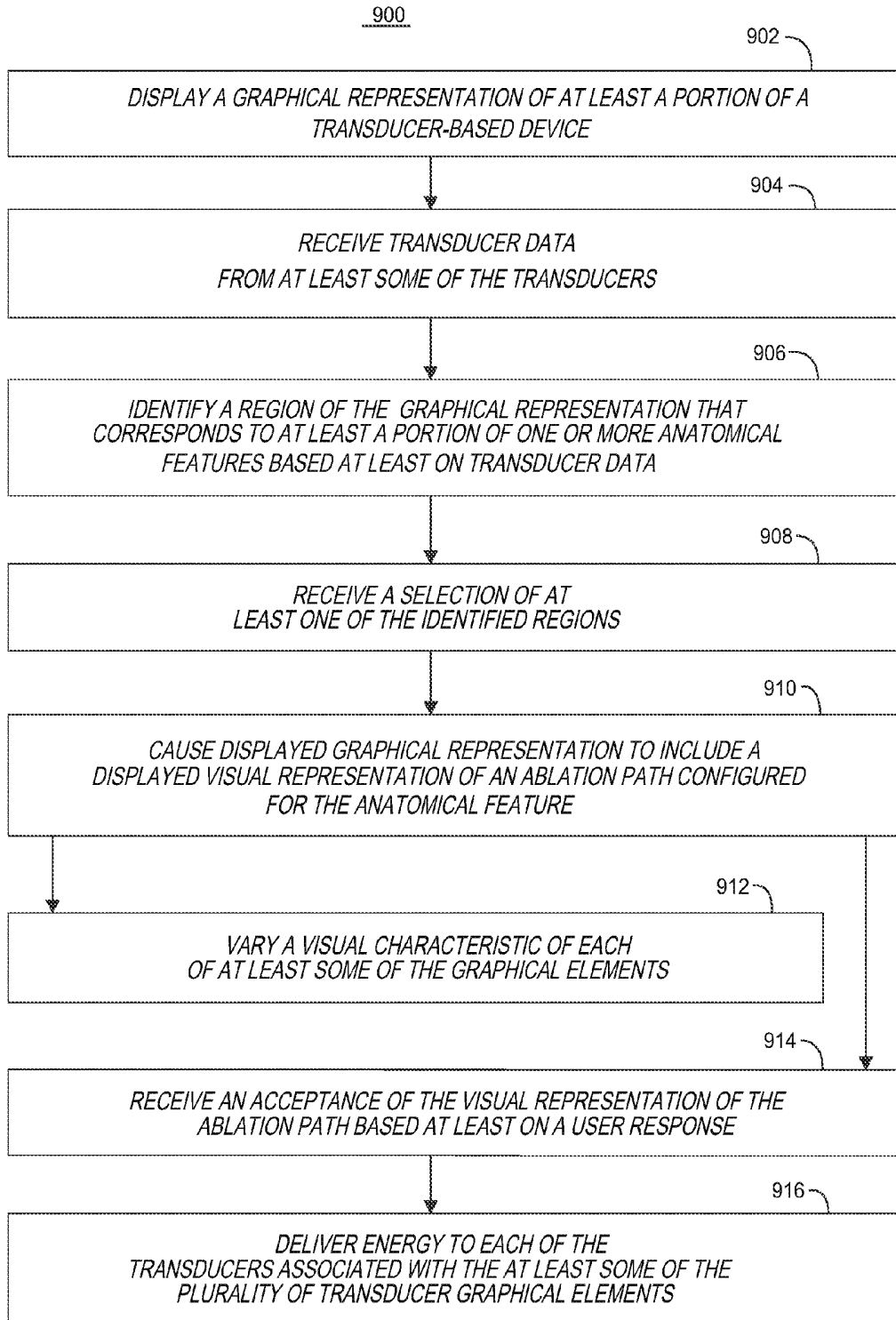

FIG. 9

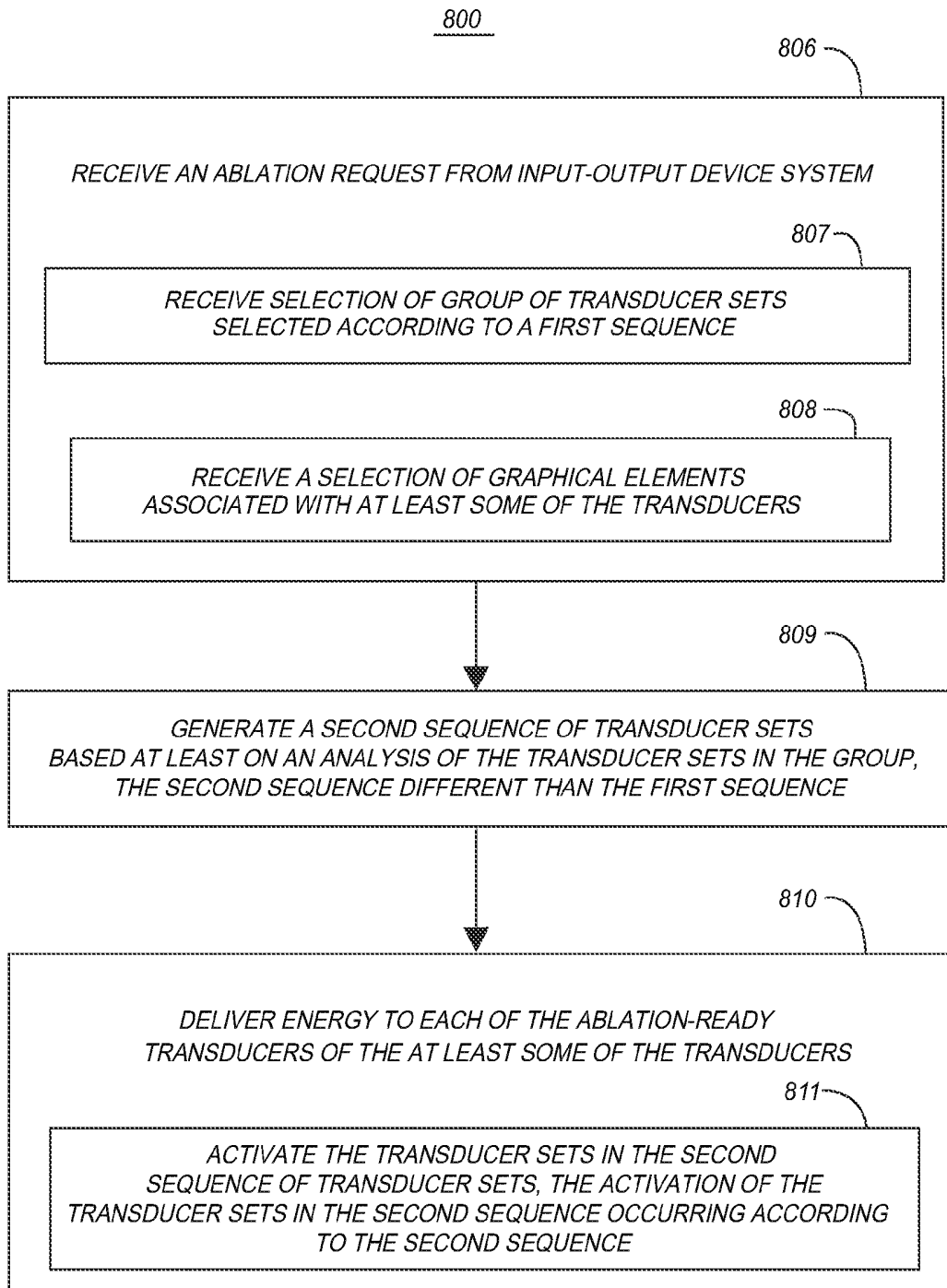

FIG. 10

SYSTEMS AND METHODS FOR SELECTING, ACTIVATING, OR SELECTING AND ACTIVATING TRANSDUCERS

CROSS-REFERENCE TO RELATED APPLICATIONS

This application claims the benefit of each of U.S. Provisional Application No. 61/649,734, filed May 21, 2012; U.S. Provisional Application No. 61/670,881, filed Jul. 12, 2012; and U.S. Provisional Application No. 61/723,311, filed Nov. 6, 2012. The entire disclosure of each of the applications cited in this paragraph is hereby incorporated herein by reference.

TECHNICAL FIELD

Aspects of this disclosure generally are related to systems and methods for selecting, activating, or selecting and activating transducers, such systems and methods applicable to, among other things, medical systems.

BACKGROUND

Cardiac surgery was initially undertaken using highly invasive open procedures. A sternotomy, which is a type of incision in the center of the chest that separates the sternum was typically employed to allow access to the heart. In the past several decades, more and more cardiac operations are performed using intravascular or percutaneous techniques, where access to inner organs or other tissue is gained via a catheter.

Intravascular or percutaneous surgeries benefit patients by reducing surgery risk, complications and recovery time. However, the use of intravascular or percutaneous technologies also raises some particular challenges. Medical devices used in intravascular or percutaneous surgery need to be deployed via catheter systems which significantly increase the complexity of the device structure. As well, doctors do not have direct visual contact with the medical devices once the devices are positioned within the body.

One example of where intravascular or percutaneous medical techniques have been employed is in the treatment of a heart disorder called atrial fibrillation. Atrial fibrillation is a disorder in which spurious electrical signals cause an irregular heartbeat. Atrial fibrillation has been treated with open heart methods using a technique known as the "Cox-Maze procedure". During this procedure, physicians create specific patterns of lesions in the left and right atria to block various paths taken by the spurious electrical signals. Such lesions were originally created using incisions, but are now typically created by ablating the tissue with various techniques including radio-frequency (RF) energy, microwave energy, laser energy and cryogenic techniques. The procedure is performed with a high success rate under the direct vision that is provided in open procedures, but is relatively complex to perform intravascularly or percutaneously because of the difficulty in creating the lesions in the correct locations. Various problems, potentially leading to severe adverse results, may occur if the lesions are placed incorrectly. It is particularly important to know the position of the various transducers which will be creating the lesions relative to cardiac features such as the pulmonary veins and mitral valve. The continuity, transmural and placement of the lesion patterns that are formed can impact the ability to block paths taken within the heart by spurious electrical signals. Other requirements for various ones of the transducers to perform additional functions such as, but not limited to, mapping various anatomical

features, mapping electrophysiological activity, sensing tissue characteristics such as impedance and temperature and tissue stimulation can also complicate the operation of the employed medical device.

In this regard, there is a need for improved intra-bodily-cavity transducer-based device systems or control mechanisms thereof with improved performance and reduced complexity as compared to conventional device systems.

SUMMARY

At least the above-discussed need is addressed and technical solutions are achieved by various embodiments of the present invention. In some embodiments, device systems and methods executed by such systems exhibit enhanced capabilities for the activation of various transducers, which may be located within a bodily cavity, such as an intra-cardiac cavity. In some embodiments, the systems or a portion thereof may be percutaneously or intravascularly delivered to position the various transducers within the bodily cavity. Various ones of the transducers may be activated to distinguish tissue from blood and may be used to deliver positional information of the device relative to various anatomical features in the bodily cavity, such as the pulmonary veins and mitral valve in an atrium. Various ones of the transducers may employ characteristics such as blood flow detection, impedance change detection or deflection force detection to discriminate between blood and tissue. Various ones of the transducers may be used to treat tissue within a bodily cavity. Treatment may include tissue ablation by way of non-limiting example. Various ones of the transducers may be used to stimulate tissue within the bodily cavity. Stimulation can include pacing by way of non-limiting example. Other advantages will become apparent from the teaching herein to those of skill in the art.

In some embodiments, a transducer-activation system may be summarized as including a data processing device system, an input-output device system communicatively connected to the data processing device system, and a memory device system communicatively connected to the data processing device system and storing a program executable by the data processing device system. The program includes display instructions configured to cause the input-output device system to display a graphical representation of at least a portion of a transducer-based device, at least part of the transducer-based device positionable within a bodily cavity. The graphical representation includes a first transducer graphical element, a second transducer graphical element, and a between graphical element. The first transducer graphical element is associated with a first transducer of the transducer-based device. The second transducer graphical element is associated with a second transducer of the transducer-based device different than and spaced apart from the first transducer. The between graphical element is associated with a region of space between the first transducer and the second transducer of the transducer-based device, the region of space not including any transducer. The program further includes selection instructions configured to cause reception of a selection from the input-output device system of the between graphical element and activation instructions configured to, in response to receiving the selection, cause activation of the first transducer and the second transducer via the input-output device system. In various ones of these embodiments, the region of space is not associated with any physical part of the transducer-based device.

The program may further include instructions configured to, in response to receiving the selection, cause the input-

output device system to change a visual characteristic of the between graphical element. The graphical representation may include a first spatial relationship between the first transducer graphical element and the second transducer graphical element that is consistent with a second spatial relationship between the corresponding first transducer and the second transducer of the transducer-based device.

The between graphical element may be a first between graphical element and the graphical representation may further include a second between graphical element associated with a region of space between a pair of transducers of the transducer-based device that is associated with a physical part of the transducer-based device. The program may further include instructions configured to cause reception of a selection from the input-output device system of the second between graphical element, and instructions configured to, in response to receiving the selection of the second between graphical element, cause activation of the pair of transducers via the input-output device system. The program may further include instructions configured to, in response to receiving the selection of the second between graphical element, cause the input-output device system to change a visual characteristic of the second between graphical element. The display instructions may include instructions configured to display the second transducer graphical element in a first direction from the first transducer graphical element. The first between graphical element may be between the second transducer graphical element and the first transducer graphical element in the graphical representation and the second between graphical element may be between the second transducer graphical element and a third transducer graphical element in the graphical representation. The display instructions may include instructions for displaying the third transducer graphical element in a second direction from the second transducer graphical element. The first direction and the second direction may be non-parallel to each other. The first between graphical element may be formed, at least in part, at a location in the graphical representation intersected by the first direction from the first transducer graphical element and the second between graphical element may be formed, at least in part, at a location in the graphical representation intersected by the second direction from the second transducer graphical element. The first between graphical element may include an elongate portion extending along the first direction and the second between graphical element may include an elongate portion extending along the second direction. The first direction and the second direction may be oblique to each other. The first direction and the second direction may form an acute angle with each other.

The program may further include instructions configured to, in response to receiving the selection of the between graphical element, cause the input-output device system to change a visual characteristic of the first transducer graphical element, the second transducer graphical element, or both the first transducer graphical element and the second transducer graphical element. In some embodiments, the selection may not include any user-selected transducer graphical element.

The input-output device system may include the transducer-based device. The transducer-based device may be a catheter device. The bodily cavity may be an intra-cardiac cavity. The catheter device may include a structure that includes a plurality of elongate members, each elongate member of the plurality of elongate members including a proximal end, a distal end, and an intermediate portion positioned between the proximal and the distal ends. The structure may be selectively moveable between a delivery configuration in which the structure is sized to be percutaneously

delivered to the bodily cavity and a deployed configuration in which the structure has a size too large to be percutaneously delivered to the bodily cavity, the first and the second transducers located on different ones of the plurality of elongate members. The respective intermediate portion of each elongate member of the plurality of elongate members may include a thickness, a front surface, and a back surface opposite across the thickness from the front surface, and the respective intermediate portions of the plurality of elongate members may be arranged front surface-toward-back surface in a stacked array when the structure is in the delivery configuration. The structure may further include a proximal portion and a distal portion, each of the proximal and the distal portions including a respective part of each of the plurality of elongate members, the proximal portion of the structure forming a first domed shape and the distal portion of the structure forming a second domed shape when the structure is in the deployed configuration.

The catheter device may include a structure that includes a proximal portion and a distal portion. The structure may be selectively moveable between a delivery configuration in which the structure is sized for percutaneous delivery to the bodily cavity, the structure arranged to be advanced distal portion first into the bodily cavity and a deployed configuration in which the structure is sized too large to be delivered percutaneously to the bodily cavity. The proximal portion of the structure may form a first domed shape and the distal portion of the structure may form a second domed shape when the structure is in the deployed configuration with the proximal and the distal portions of the structure arranged in a clam shell configuration when the structure is in the deployed configuration.

The transducer-based device may include a structure that includes a plurality of elongate members. The between graphical element may be a first between graphical element and the graphical representation may further include a third transducer graphical element and a second between graphical element, the third transducer graphical element associated with a third transducer of the transducer-based device and the second between graphical element associated with a region of space between the second transducer and the third transducer, the region of space between the second transducer and the third transducer not including any transducer. The second transducer and the third transducer may be located on a same elongate member of the plurality of elongate members and the first transducer and the second transducer may be located on different elongate members of the plurality of elongate members.

The input-output device system may include an energy source device system connected to the first transducer and the second transducer. The activation instructions may be further configured to cause energy from the energy source device system to be delivered to the first transducer and the second transducer in a manner that: (a) a portion of the energy delivered to the first transducer is transmitted by the first transducer, (b) a portion of the energy delivered to the second transducer is transmitted by the second transducer, or both (a) and (b). The activation instructions may be further configured to cause energy from the energy source device system to be delivered to the first transducer and the second transducer in a manner that, (a) a portion of the energy delivered to the first transducer is transmitted by the first transducer to the second transducer, or (b) a portion of the energy delivered to the second transducer is transmitted by the second transducer to the first transducer, or both (a) and (b). The activation instructions may be further configured to cause energy from the energy source device system to be delivered to the first trans-

ducer and the second transducer, the energy sufficient to cause ablation of tissue in the bodily cavity. The activation instructions may be further configured to cause a portion of the energy delivered to the first transducer and the second transducer to be delivered between the first transducer and the second transducer across at least part of the region of space. The energy may be sufficient to cause bipolar ablation of the tissue in the bodily cavity. The first transducer may be adjacently spaced from the second transducer along a physical path extending between the first transducer and the second transducer over at least part of an opening in a surface structure of the catheter device, and the energy may be sufficient to ablate a portion of the tissue extending along the physical path.

The between graphical element may be a first between graphical element of a group of between graphical elements included in the graphical representation, each between graphical element of the group of between graphical elements associated with a respective region of space between transducers of the transducer-based device that does not include any transducer and is not associated with any physical part of the transducer-based device. The program may further include determination instructions configured to cause determination, via input received from the input-output device system, of which of a plurality of regions of space, respectively between corresponding transducers of the transducer-based device and respectively not associated with any physical part of the transducer-based device, are and which are not acceptable for activation of the respectively corresponding transducers. The display instructions may be further configured to cause the input-output device system to display the between graphical elements associated with the regions of space determined, according to the determination instructions, to be acceptable for activation of the respectively corresponding transducers with different visual characteristics than visual characteristics of the between graphical elements associated with the regions of space determined, according to the determination instructions, to be not acceptable for activation of the respectively corresponding transducers.

The between graphical element may be a first between graphical element of a plurality of between graphical elements included in the graphical representation, each between graphical element of a first subset of the plurality of between graphical elements associated with a respective region of space between transducers of the transducer-based device that does not include any transducer and that is not associated with any physical part of the transducer-based device, and each between graphical element of a second subset of the plurality of between graphical elements associated with a respective region of space between transducers of the transducer-based device that does not include any transducer and that is associated with a physical part of the transducer-based device. The program may further include determination instructions configured to cause determination, via input received from the input-output device system, of which of a plurality of regions of space, respectively between corresponding transducers of the transducer-based device, are and which are not acceptable for activation of the respectively corresponding transducers. The display instructions may be further configured to cause the input-output device system to display the between graphical elements associated with the regions of space determined, according to the determination instructions, to be acceptable for activation of the respectively corresponding transducers with different visual characteristics than visual characteristics of the between graphical elements associated with the regions of space determined,

according to the determination instructions, to be not acceptable for activation of the respectively corresponding transducers.

The transducer-based device may be a catheter device and the input-output device system may include an energy source device system connected to the transducers of the catheter device. The activation instructions may be further configured to cause energy from the energy source device system to be delivered to each of the transducers associated with the regions of space determined, according to the determination instructions, to be acceptable for activation of the respectively corresponding transducers, the energy sufficient to cause ablation of tissue in the bodily cavity. The determination instructions may be further configured to require that, in order for a between graphical element to be determined to be associated with a region of space acceptable for the activation of the respectively corresponding transducers, the corresponding region of space be determined to be associated with an anatomical feature of the bodily cavity that is acceptable for the ablation of the tissue in the bodily cavity. The activation may include bipolar transducer activation, monopolar transducer activation, or both bipolar transducer activation and monopolar transducer activation. The display instructions may be further configured to cause the input-output device system to display the between graphical elements only for the regions of space determined by the determination instructions, to be acceptable for activation of the respectively corresponding transducers.

Each of the first transducer graphical element and the second transducer graphical element may form part of a plurality of transducer graphical elements included in the graphical representation, each of the transducer graphical elements associated with a respective transducer of a plurality of transducers of the transducer-based device, the plurality of transducers arranged in a spaced apart distribution. The between graphical element may be a first between graphical element of a plurality of between graphical elements included in the graphical representation, each of the between graphical elements associated with a respective region of space between a corresponding pair of the transducers in the spaced apart distribution, each pair of the transducers in the spaced apart distribution having at least one different transducer than another of the other pairs of the transducers in the spaced apart distribution, each respective region of space not including any transducer. The selection instructions may be further configured to cause reception of independent selections from the input-output device system of each of at least two of the plurality of between graphical elements, the corresponding pairs of the transducers in the spaced apart distribution associated with the selected at least two of the plurality of between graphical elements having a same transducer. The activation instructions may be further configured to cause activation, via the input-output device system, of each corresponding pair of the transducers in the spaced apart distribution associated with the selected at least two of the plurality of between graphical elements.

The transducers in the spaced apart distribution associated with the selected at least two of the between graphical elements may be selected transducers. The input-output device system may include an energy source device system connected to at least the selected transducers and the activation instructions may further include instructions configured to cause the energy source device system to deliver energy to the selected transducers. The transducer-based device may be a catheter device and the energy may be sufficient for ablating tissue.

Each pair of transducers associated with the selected at least two of the between graphical elements may be a selected pair of transducers. The transducer-based device may be a catheter device and the bodily cavity may be an intra-cardiac cavity. Each transducer in each selected pair of transducers may be configured to detect electrophysiological activity in the intra-cardiac cavity at a location at least proximate the transducer in the selected pair of transducers, and the activation instructions may be further configured to respectively cause generation of a combined electrogram from each selected pair of transducers based at least on electrophysiological activity data received from the transducers of the selected pair of transducers.

The selected at least two of the plurality of between graphical elements may include the first between graphical element and a second between graphical element, the second between graphical element associated with a region of space between a pair of transducers of the transducer-based device that does not include any transducer and is associated with a physical part of the transducer-based device.

The program may further include instructions configured to cause generation of a combined electrogram from both the first transducer and the second transducer. The activation instructions may be further configured to cause bipolar activation between the first and the second transducers. The first transducer graphical element may have a different size than the second transducer graphical element, the different sizes corresponding to respectively different sizes of the first transducer and the second transducer.

Various systems may include combinations and subsets of all those summarized above.

In some embodiments, a catheter device system may be summarized as including a catheter device that includes a plurality of transducers and a structure that includes one or more surfaces, at least a portion of the one or more surfaces defining one or more openings in the structure. The plurality of transducers are arranged on the structure in a spaced apart distribution that is positionable within a bodily cavity, the spaced apart distribution including at least a first transducer, a second transducer, and a third transducer. The first transducer is adjacently spaced from the second transducer along a first physical path extending between the second and the first transducers, at least part of the first physical path extending over at least part of an opening of the one or more openings in the structure. The third transducer is adjacently spaced from the second transducer along a second physical path extending between the second and the third transducers over at least part of the one or more surfaces. The second physical path is non-parallel with the first physical path. The catheter device system further includes a data processing device system, an input-output device system that includes the catheter device and is communicatively connected to the data processing device system, a display device system, an energy source device system, and a memory device system communicatively connected to the data processing device system and storing a program. The program is executable by the data processing device system to cause the catheter device system to execute a method of activating at least some of a plurality of transducers of the catheter device. The method may be summarized as including generating an image via the display device system, the image at least depicting a spatial relationship between at least some of the transducers in the spaced apart distribution, the image including a plurality of transducer graphical elements and a plurality of between graphical elements. Each of the transducer graphical elements is associated with a respective one of the at least some of the transducers in the spaced apart distribution. Each of the between

graphical elements includes a first end, a second end, and an elongate portion extending between the first and the second ends. A first one of the plurality of between graphical elements is representative of the first physical path and a second one of the plurality of between graphical elements representative of the second physical path, the elongate portions of the first and the second ones of the plurality of between graphical elements depicted extending along non-parallel directions at respective locations at least proximate the respective transducer graphical element associated with the second transducer. The method further includes processing one or more operations of the input-output device system according to a selection mode configured to allow a selection of at least the first one of the plurality of between graphical elements, and processing one or more operations of the input-output device system according to an activation mode configured to activate a pair of the transducers in the spaced apart distribution in response to the selection of the first one of the plurality of between graphical elements to cause energy provided by the energy source device system to be delivered to the pair of the transducers in the spaced apart distribution, the energy sufficient for ablating tissue along the first physical path represented by the first one of the plurality of between graphical elements in the selection.

The elongate portions of the first and the second ones of the plurality of between graphical elements may be depicted extending obliquely with respect to one another at the respective locations at least proximate the respective transducer graphical element associated with the second transducer. The elongate portions of the first and the second ones of the plurality of between graphical elements may be depicted extending with respect to one another to define an acute angle therebetween.

The method may include causing the input-output device system to vary a visual characteristic of at least the first one of the plurality of between graphical elements in response to the selection of the first one of the plurality of between graphical elements. The method may further include causing the input-output device system to vary a visual characteristic of at least one of the respective transducer graphical elements associated with the first transducer and the second transducer in response to the selection of the first one of the plurality of between graphical elements. In some embodiments, the selection may not include any user-selected transducer graphical element.

The structure may include a plurality of elongate members, each elongate member of the plurality of elongate members including a proximal end, a distal end and an intermediate portion positioned between the proximal and distal ends. The structure may be selectively moveable between a delivery configuration in which the structure is sized to be percutaneously delivered to the bodily cavity and a deployed configuration in which the structure has a size too large to be percutaneously delivered to the bodily cavity, the plurality of transducers located on at least some of the plurality of elongate members. Each of the first transducer and the second transducer may be located on a different elongate member of the at least some of the plurality of elongate members and each of the second transducer and the third transducer may be located on a same elongate member of the at least some of the plurality of elongate members. The respective intermediate portion of each elongate member of the plurality of elongate members may include a thickness, a front surface and a back surface opposite across the thickness from the front surface, and the respective intermediate portions of the plurality of elongate members may be arranged front surface-toward-back surface in a stacked array when the structure is in the

delivery configuration. The structure may include a proximal portion and a distal portion, each of the proximal and the distal portions including a respective part of each of the plurality of elongate members, the proximal portion of the structure forming a first domed shape and the distal portion of the structure forming a second domed shape when the structure is in the deployed configuration.

A portion of the energy delivered to the pair of the transducers in the spaced apart distribution may be delivered between the transducers of the pair of the transducers in the spaced apart distribution.

Various methods may include combinations and subsets of all those summarized above.

In some embodiments, a transducer-activation system may be summarized as including a data processing device system, an input-output device system communicatively connected to the data processing device system, and a memory device system communicatively connected to the data processing device system and storing a program executable by the data processing device system. The data processing device system is configured by the program at least to cause the input-output device system to display a graphical representation of at least a portion of a transducer-based device, at least part of the transducer-based device positionable within a bodily cavity, and the graphical representation including a first transducer graphical element, a second transducer graphical element, and a between graphical element. The first transducer graphical element is associated with a first transducer of the transducer-based device, the second transducer graphical element is associated with a second transducer of the transducer-based device different than and spaced apart from the first transducer, and the between graphical element associated with a region of space between the first transducer and the second transducer of the transducer-based device, the region of space not including any transducer. The data processing device system is further configured by the program at least to receive a selection from the input-output device system of the between graphical element, and cause activation, in response to receiving the selection, of the first transducer and the second transducer via the input-output device system. The region of space may not be associated with any physical part of the transducer-based device. In some embodiments, the selection may not include any user-selected transducer graphical element.

In some embodiments, a memory device system is communicatively connected to a data processing device system, and the data processing device system is further communicatively connected to an input-output device system. A transducer-activation method executed by a data processing device system according to a program stored by the memory device system may be summarized as including causing the input-output device system to display a graphical representation of at least a portion of a transducer-based device, at least part of the transducer-based device positionable within a bodily cavity. The graphical representation includes a first transducer graphical element, a second transducer graphical element, and a between graphical element, the first transducer graphical element associated with a first transducer of the transducer-based device, the second transducer graphical element associated with a second transducer of the transducer-based device different than and spaced apart from the first transducer, and the between graphical element associated with a region of space between the first transducer and the second transducer of the transducer-based device, the region of space not including any transducer. The method further includes receiving a selection from the input-output device system of the between graphical element, and causing activation, in

response to receiving the selection, of the first transducer and the second transducer via the input-output device system. The region of space may not be associated with any physical part of the transducer-based device. In some embodiments, the selection may not include any user-selected transducer graphical element.

In some embodiments, a computer-readable storage medium system may be summarized as including one or more computer-readable storage mediums storing a program executable by one or more data processing devices of a data processing device system communicatively connected to an input-output device system. The program includes a display module configured to cause the input-output device system to display a graphical representation of at least a portion of a transducer-based device, at least part of the transducer-based device positionable within a bodily cavity. The graphical representation includes a first transducer graphical element, a second transducer graphical element, and a between graphical element, the first transducer graphical element associated with a first transducer of the transducer-based device, the second transducer graphical element associated with a second transducer of the transducer-based device different than and spaced apart from the first transducer, and the between graphical element associated with a region of space between the first transducer and the second transducer of the transducer-based device, the region of space not including any transducer. The program further includes a selection module configured to cause reception of a selection from the input-output device system of the between graphical element, and an activation module configured to, in response to receiving the selection, cause activation of the first transducer and the second transducer via the input-output device system. The region of space may not be associated with any physical part of the transducer-based device. In some embodiments, the selection may not include any user-selected transducer graphical element. In some embodiments, the computer-readable storage medium system is a non-transitory computer-readable storage medium system including one or more non-transitory computer-readable storage mediums storing the program.

In some embodiments, a transducer-activation system may be summarized as including a data processing device system, an input-output device system communicatively connected to the data processing device system, and a memory device system communicatively connected to the data processing device system and storing a program executable by the data processing device system. The program includes graphical interface instructions configured to cause the input-output device system to display a graphical interface including a graphical representation of at least some of a plurality of graphical elements, each of the plurality of graphical elements respectively associated with a respective one of a plurality of transducer sets, each respective transducer set including at least one of a plurality of transducers included as part of a transducer-based device, and each respective transducer set having at least one different transducer than another of the other transducer sets. The program includes input instructions configured to cause reception of transducer data via the input-output device system, the transducer data indicating data acquired by the plurality of transducers. The program includes identification instructions configured to cause identification of ablation-ready transducers of the plurality of transducers as transducers that are adjacent a region of space deemed, based at least on an analysis of the transducer data, acceptable for ablation, and not-ablation-ready transducers of the plurality of transducers as transducers that are adjacent a region of space deemed, based at least on the analysis of the

transducer data, not acceptable for ablation. The graphical interface includes a first set of visual characteristics associated with the graphical elements that are associated with each of the transducers sets that include the ablation-ready transducers, and includes a second set of visual characteristics associated with the graphical elements that are associated with the transducer sets that include the not-ablation-ready transducers, the first set of visual characteristics being different than the second set of visual characteristics. The program includes ablation request instructions configured to cause reception of an ablation request from the input-output device system, the ablation request configured to request ablation by at least some of the plurality of transducers. The program further includes activation instructions configured to, in response to receiving the ablation request from the input-output device system, cause energy from an energy source device system to be delivered to each of the plurality of ablation-ready transducers in the at least some of the plurality of transducers, and non-activation instructions configured to cause prevention of delivery of energy from the energy source device system to each of the plurality of not-ablation-ready transducers.

The ablation request instructions may be configured to cause reception of a selection from the input-output device system of the graphical elements associated with the respective transducer sets including the at least some of the plurality of transducers.

Each transducer set may include a single transducer of the plurality of transducers. Each transducer set may include at least a pair of the plurality of transducers. The plurality of transducers may be arranged in a distribution, the plurality of transducers positionable within a bodily cavity, and each pair of the plurality of transducers may be a pair of adjacent transducers in the distribution. Each of the transducers in the distribution may be spaced apart from each of the other transducers in the distribution.

The first set of visual characteristics may be associated only with the graphical elements that are associated with the transducer sets each consisting of transducers identified by the identification instructions as only being ablation-ready transducers. The second set of visual characteristics may be associated only with the graphical elements that are associated with the transducer sets each having at least one transducer identified by the identification instructions as being a not-ablation-ready transducer. The graphical interface instructions may be further configured to cause the input-output device system to display only the graphical elements associated with transducer sets consisting of transducers identified by the identification instructions as only being ablation-ready transducers.

The at least some of the plurality of transducers may be an ablation-requested transducer set. The program may further include determination instructions configured to cause determination of whether the ablation-requested transducer set includes a not-ablation-ready transducer, and ablation denial instructions configured to, if it is determined according to the determination instructions that the ablation-requested transducer set includes the not-ablation-ready transducer, cause denial of the ablation request, at least with respect to the not-ablation-ready transducer in the ablation-requested transducer set. The program may further include determination instructions configured to cause determination of whether the ablation-requested transducer set includes a not-ablation-ready transducer, and ablation denial instructions configured to cause denial of the ablation request if it is determined

according to the determination instructions that the ablation-requested transducer set includes the not-ablation-ready transducer.

The input-output device system may include the transducer-based device. The transducer-based device may be a catheter device with a portion thereof sized to be positionable within a bodily cavity. The bodily cavity may be an intracardiac cavity. The catheter device may include a structure that includes a plurality of elongate members, each elongate member of the plurality of elongate members including a proximal end, a distal end and an intermediate portion positioned between the proximal and the distal ends. The structure may be selectively moveable between a delivery configuration in which the structure is sized to be percutaneously delivered to the bodily cavity and a deployed configuration in which the structure has a size too large to be percutaneously delivered to the bodily cavity, the plurality of transducers located on at least some of the plurality of elongate members. At least one of the transducer sets may include at least two transducers identified by the identification instructions as being not-ablation-ready transducers, the at least two transducers located on different elongate members of the at least some of the plurality of elongate members. The respective intermediate portion of each elongate member of the plurality of elongate members may include a thickness, a front surface, and a back surface opposite across the thickness from the front surface, and the respective intermediate portions of the plurality of elongate members may be arranged front surface-toward-back surface in a stacked array when the structure is in the delivery configuration. The structure may further include a proximal portion and a distal portion, each of the proximal and the distal portions including a respective part of each of the plurality of elongate members, the proximal portion of the structure forming a first domed shape and the distal portion of the structure forming a second domed shape when the structure is in the deployed configuration.

The catheter device may include a structure that includes a proximal portion and a distal portion. The structure may be selectively moveable between a delivery configuration in which the structure is sized for percutaneous delivery to the bodily cavity, the structure arranged to be advanced distal portion first into the bodily cavity, and a deployed configuration in which the structure is sized too large to be delivered percutaneously to the bodily cavity. The proximal portion of the structure may form a first domed shape and the distal portion of the structure may form a second domed shape when the structure is in the deployed configuration, the proximal and the distal portions of the structure arranged in a clam shell configuration when the structure is in the deployed configuration.

The plurality of transducers may be arranged in a distribution, the plurality of transducers positionable within a bodily cavity. The transducer data may include data associated with an electrical characteristic of tissue in the bodily cavity. The electrical characteristic may be an electrical impedance of the tissue in the bodily cavity. The transducer data may include data associated with a flow characteristic of fluid in the bodily cavity.

The plurality of transducers may be arranged in a distribution, the plurality of transducers positionable within a bodily cavity. The identification instructions may include instructions configured to cause a requirement that, in order for a region of space to be deemed acceptable for ablation, the region of space be determined, based at least on the analysis of the transducer data, to be associated with a tissue in the bodily cavity that is acceptable for ablation, and the identification instructions may further include instructions config-

ured to cause a requirement that, in order for a region of space to be deemed not acceptable for ablation, the region of space be determined, based at least on the analysis of the transducer data, to be associated with a tissue in the bodily cavity that is not acceptable for ablation. The bodily cavity may be an intra-cardiac cavity and the tissue in the bodily cavity that is not acceptable for ablation may be blood. The identification instructions may include instructions configured to cause a requirement that, in order for a region of space to be deemed acceptable for ablation, the region of space be determined, based at least on the analysis of the transducer data, to be associated with an anatomical feature of the bodily cavity that is acceptable for ablation, and the identification instructions may further include instructions configured to cause a requirement that, in order for a region of space to be deemed not acceptable for ablation, the region of space be determined, based at least on the analysis of the transducer data, to be associated with an anatomical feature of the bodily cavity that is not acceptable for ablation. The plurality of transducers may be arranged in a distribution, the plurality of transducers positionable within a bodily cavity that includes a tissue wall surface interrupted by one or more ports in fluid communication with the bodily cavity. The identification instructions may include instructions configured to cause a requirement that, in order for a region of space to be deemed not acceptable for ablation, the region of space be determined, based at least on the analysis of the transducer data, to overlie at least part of a port of the one or more ports.

Each respective transducer set may have at least one different transducer than each of the other transducer sets.

Various systems may include combinations and subsets of all those summarized above.

In some embodiments, a transducer-activation system may be summarized as including a data processing device system, an input-output device system communicatively connected to the data processing device system, and a memory device system communicatively connected to the data processing device system and storing a program executable by the data processing device system. The data processing device system is configured by the program at least to cause the input-output device system to display a graphical interface including a graphical representation of at least some of a plurality of graphical elements, each of the plurality of graphical elements respectively associated with a respective one of a plurality of transducer sets. Each respective transducer set includes at least one of a plurality of transducers included as part of a transducer-based device, and each respective transducer set has at least one different transducer than another of the other transducer sets. The data processing device system is configured by the program at least to receive transducer data via the input-output device system, the transducer data indicating data acquired by the plurality of transducers. The data processing device system is configured by the program at least to identify ablation-ready transducers of the plurality of transducers as transducers that are adjacent a region of space deemed, based at least on an analysis of the transducer data, acceptable for ablation, and not-ablation-ready transducers of the plurality of transducers as transducers that are adjacent a region of space deemed, based at least on the analysis of the transducer data, not acceptable for ablation. The graphical interface includes a first set of visual characteristics associated with the graphical elements that are associated with each of the transducers sets that include the ablation-ready transducers, and includes a second set of visual characteristics associated with the graphical elements that are associated with the transducer sets that include the not-ablation-ready transducers, the first set of visual characteristics being different

ent than the second set of visual characteristics. The data processing device system is configured by the program at least to receive an ablation request from the input-output device system, the ablation request configured to request ablation by at least some of the plurality of transducers. The data processing device system is configured by the program at least to cause, in response to receiving the ablation request from the input-output device system, energy from an energy source device system to be delivered to each of the plurality of ablation-ready transducers in the at least some of the plurality of transducers, and prevent delivery of energy from the energy source device system to each of the plurality of not-ablation-ready transducers.

In some embodiments, a memory device system is communicatively connected to a data processing device system, the data processing device system further communicatively connected to an input-output device system. A transducer-activation method executed by the data processing device system according to a program stored by the memory device system may be summarized as including causing the input-output device system to display a graphical interface including a graphical representation of at least some of a plurality of graphical elements, each of the plurality of graphical elements respectively associated with a respective one of a plurality of transducer sets, each respective transducer set including at least one of a plurality of transducers included as part of a transducer-based device, and each respective transducer set having at least one different transducer than another of the other transducer sets. The transducer-activation method includes receiving transducer data via the input-output device system, the transducer data indicating data acquired by the plurality of transducers. The transducer-activation method includes identifying ablation-ready transducers of the plurality of transducers as transducers that are adjacent a region of space deemed, based at least on an analysis of the transducer data, acceptable for ablation, and not-ablation-ready transducers of the plurality of transducers as transducers that are adjacent a region of space deemed, based at least on the analysis of the transducer data, not acceptable for ablation. The graphical interface includes a first set of visual characteristics associated with the graphical elements that are associated with each of the transducers sets that includes the ablation-ready transducers, and includes a second set of visual characteristics associated with the graphical elements that are associated with the transducer sets that includes the not-ablation-ready transducers, the first set of visual characteristics being different than the second set of visual characteristics. The transducer-activation method includes receiving an ablation request from the input-output device system, the ablation request configured to request ablation by at least some of the plurality of transducers. The transducer-activation method further includes causing, in response to receiving the ablation request from the input-output device system, energy from an energy source device system to be delivered to each of the plurality of ablation-ready transducers in the at least some of the plurality of transducers, and preventing delivery of energy from the energy source device system to each of the plurality of not-ablation-ready transducers.

In some embodiments, a computer-readable storage medium system may be summarized as including one or more computer-readable storage mediums storing a program executable by one or more data processing devices of a data processing device system communicatively connected to an input-output device system. The program includes a graphical interface module configured to cause the input-output device system to display a graphical interface including a graphical representation of at least some of a plurality of

graphical elements, each of the plurality of graphical elements respectively associated with a respective one of a plurality of transducer sets, each respective transducer set including at least one of a plurality of transducers included as part of a transducer-based device, and each respective transducer set having at least one different transducer than another of the other transducer sets. The program includes an input module configured to cause reception of transducer data via the input-output device system, the transducer data indicating data acquired by the plurality of transducers. The program includes an identification module configured to cause identification of ablation-ready transducers of the plurality of transducers as transducers that are adjacent a region of space deemed, based at least on an analysis of the transducer data, acceptable for ablation, and not-ablation-ready transducers of the plurality of transducers as transducers that are adjacent a region of space deemed, based at least on the analysis of the transducer data, not acceptable for ablation. The graphical interface includes a first set of visual characteristics associated with the graphical elements that are associated with each of the transducers sets that includes the ablation-ready transducers, and includes a second set of visual characteristics associated with the graphical elements that are associated with the transducer sets that includes the not-ablation-ready transducers, the first set of visual characteristics being different than the second set of visual characteristics. The program includes an ablation request module configured to cause reception of an ablation request from the input-output device system, the ablation request configured to request ablation by at least some of the plurality of transducers. The program further includes an activation module configured to, in response to receiving the ablation request from the input-output device system, cause energy from an energy source device system to be delivered to each of the plurality of ablation-ready transducers in the at least some of the plurality of transducers, and a non-activation module configured to cause prevention of delivery of energy from the energy source device system to each of the plurality of not-ablation-ready transducers. In some embodiments, the computer-readable storage medium system is a non-transitory computer-readable storage medium system including one or more non-transitory computer-readable storage mediums storing the program.

In some embodiments, a transducer-based device system may be summarized as including a data processing device system. The transducer-based device includes an input-output device system communicatively connected to the data processing device system. The input-output device system includes a transducer-based device, at least part of the transducer-based device positionable within a bodily cavity, and the transducer-based device including a structure that positions a plurality of transducers in a spaced apart distribution. The transducer-based device further includes a memory device system communicatively connected to the data processing device system and storing a program executable by the data processing device system. The program includes graphical representation instructions configured to cause the input-output device system to display a graphical representation of at least a portion of the transducer-based device. The graphical representation includes a plurality of transducer graphical elements and a plurality of between graphical elements. Each of the transducer graphical elements is associated with a respective transducer of the plurality of transducers of the transducer-based device, and each of the between graphical elements is associated with a region of space between a pair of the transducers in the spaced apart distribution, each region of space not including any transducer, and

no two of the pairs of the transducers having an identical pair of the transducers. The plurality of transducer graphical elements and at least a portion of the plurality of between graphical elements are arranged in a plurality of rows and a plurality of columns. The transducer graphical elements and the between graphical elements in each respective one of the plurality of rows are interleaved with respect to one another along the respective one of the plurality of rows. The transducer graphical elements and the between graphical elements in each respective one of the plurality of columns are interleaved with respect to one another along the respective one of the plurality of columns. Each one of the plurality of columns shares a same transducer graphical element with one of the plurality of rows. The program further includes selection instructions configured to cause reception of independent selections from the input-output device system of each of at least two of the plurality of between graphical elements, and path-display instructions configured to, in response to receiving the independent selections, cause the graphical representation to include, during a time interval that occurs (a) during the receiving of the independent selections, (b) after a completion of the receiving of the independent selections, or both (a) and (b), a displayed visual representation of a path passing through at least a portion of each of the selected between graphical elements, the displayed visual representation of the path extending between at least two of the plurality of rows and between at least two of the plurality of columns.

The path-display instructions may be further configured to cause the displayed visual representation of the path to pass through at least some of the transducer graphical elements associated with the transducers in the pairs of transducers between which the regions of space associated with the selected between graphical elements respectively reside.

Each respective one of the plurality of columns may exclude any of the between graphical elements included in each of the plurality of rows. The displayed visual representation of the path may include a path segment that proceeds diagonally between a first node located at a first junction of a first one of the plurality of columns and a first one of the plurality of rows and a second node located at a second junction of a second one of the plurality of columns and a second one of the plurality of rows, the first junction being different than the second junction. The path-display instructions may include instructions configured to cause the displayed graphical representation to change a visual characteristic of the selected between graphical elements as at least part of forming the displayed visual representation of the path. The path-display instructions may include instructions configured to, in response to receiving the independent selections, cause the displayed graphical representation to change, during the time interval, a visual characteristic of the at least some of the transducer graphical elements associated with the transducers in the pairs of the transducers between which the regions of space associated with the selected between graphical elements respectively reside.

The graphical representation may be three-dimensional. The plurality of rows and the plurality of columns may be depicted as a three-dimensional arrangement in the graphical representation. At least two of the plurality of columns may be depicted in the graphical representation extending along respective directions that converge with respect to one another. At least two of the plurality of columns may be depicted in the graphical representation extending along non-parallel directions. At least two of the plurality of rows may be depicted in the graphical representation extending along parallel directions. The plurality of rows and the plurality of columns may be depicted in the graphical representation in an

arrangement in which the columns are circumferentially arranged. The plurality of rows and the plurality of columns may be depicted in the graphical representation in an arrangement having a generally spherical shape.

At least a first one of the plurality of between graphical elements may be depicted in the graphical representation positioned between two adjacent ones of the plurality of rows, and at least a second one of the plurality of between graphical elements may be depicted in the graphical representation positioned between two adjacent ones of the plurality of columns. Each of at least some of the plurality of between graphical elements may include a first end, a second end and an elongate portion extending between the first end and the second end. Each of the first end and the second end of each of the at least some of the plurality of between graphical elements may connect to a transducer graphical element in the graphical representation. The elongate portions of at least two of the at least some of the plurality of between graphical elements may extend along respective directions defining an acute angle therebetween.

The program may further include activation instructions configured to, in response to receiving the independent selections, cause activation, via the input-output device system, of the transducers in the pairs of the transducers between which the regions of space associated with the selected between graphical elements respectively reside. The input-output device system may include an energy source device system configured to be connected to the transducers in the pairs of the transducers between which the regions of space associated with the selected between graphical elements respectively reside, the activation instructions configured to cause the activation to occur during the time interval. The activation instructions may include instructions configured to, in response to receiving the independent selections, cause the energy source device system to deliver energy to the transducers in the pairs of the transducers between which the regions of space associated with the selected between graphical elements respectively reside, the energy sufficient for ablating tissue, and the activation instructions configured to cause the energy to be delivered during the time interval. The input-output device system may include an indifferent electrode configured to receive a portion of the energy delivered to at least one of the transducers in the pairs of the transducers between which the regions of space associated with the selected between graphical elements respectively reside. The activation instructions may include instructions configured to, in response to receiving the independent selections, cause the energy source device system to deliver energy to the transducers in the pairs of the transducers between which the regions of space associated with the selected between graphical elements respectively reside, the energy to be delivered in a manner that (d) a portion of the energy delivered to a first transducer of each pair of the transducers is transmitted by the first transducer, (e) a portion of the energy delivered to a second transducer of each pair of the transducers is transmitted by the second transducer, or both (d) and (e), and the activation instructions configured to cause the energy to be delivered during the time interval. The transducer-based device may be a catheter device and the bodily cavity may be an intra-cardiac cavity. One of the pairs of the transducers between which one of the regions of space associated with one of the selected between graphical elements resides includes a first transducer and a second transducer and each of the first transducer and the second transducer may be configured to detect electrophysiological activity in the intra-cardiac cavity at a location at least proximate the respective transducer. The activation instructions may include instruc-

tions configured to, in response to receiving the independent selection of the one of the selected between graphical elements, cause generation of a combined electrogram based upon electrophysiological activity data received from the first transducer and the second transducer.

At least one of the regions of space associated with the between graphical elements may not be associated with any physical part of the transducer-based device. At least one of the regions of space associated with the between graphical elements may be associated with a physical part of the transducer-based device. The structure may include one or more surfaces, at least a portion of the one or more surfaces defining one or more openings in the structure. A first particular one of the plurality of between graphical elements may be associated with a region of space between a first particular one of the pairs of the transducers, the first particular one of the pairs of the transducers being spaced with respect to one another over a surface of the one or more surfaces, and a second particular one of the plurality of between graphical elements may be associated with a region of space between a second particular one of the pairs of the transducers, the second particular one of the pairs of the transducers being spaced with respect to one another over at least part of an opening of the one or more openings in the structure.

The transducer-based device may be a catheter device. The structure may include a plurality of elongate members, each elongate member of the plurality of elongate members including a proximal end, a distal end and an intermediate portion positioned between the proximal and the distal ends, the structure selectively moveable between a delivery configuration in which the structure is sized to be percutaneously delivered to the bodily cavity and a deployed configuration in which the structure has a size too large to be percutaneously delivered to the bodily cavity, the plurality of transducers located on at least some of the plurality of elongate members. A first particular one of the plurality of between graphical elements may be associated with a region of space between a first particular one of the pairs of the transducers. A second particular one of the plurality of between graphical elements may be associated with a region of space between a second particular one of the pairs of the transducers. Each transducer in the first particular one of the pairs of the transducers may be located on a same elongate member of the at least some of the plurality of elongate members, and each transducer in the second particular one of the pairs of the transducers may be located on a different elongate member of the at least some of the plurality of elongate members. The respective intermediate portion of each elongate member of the plurality of elongate members may include a thickness, a front surface, and a back surface opposite across the thickness from the front surface, and the respective intermediate portions of the plurality of elongate members may be arranged front surface-toward-back surface in a stacked array when the structure is in the delivery configuration. The structure may include a proximal portion and a distal portion, each of the proximal and the distal portions including a respective part of each of the plurality of elongate members, the proximal portion of the structure forming a first domed shape and the distal portion of the structure forming a second domed shape when the structure is in the deployed configuration.

The structure may include a proximal portion and a distal portion, and the structure may be selectively moveable between a delivery configuration in which the structure is sized for percutaneous delivery to the bodily cavity, the structure arranged to be advanced distal portion first into the bodily cavity, and a deployed configuration in which the structure is sized too large to be delivered percutaneously to the bodily

cavity, the proximal portion of the structure forming a first domed shape and the distal portion of the structure forming a second domed shape when the structure is in the deployed configuration, the proximal and the distal portion of the structure arranged in a clam shell configuration when the structure is in the deployed configuration.

Various systems may include combinations and subsets of all those summarized above.

In some embodiments, a transducer-activation system may be summarized as including a data processing device system, an input-output device system communicatively connected to the data processing device system, the input-output device system including a transducer-based device, at least part of the transducer-based device positionable within a bodily cavity, and the transducer-based device including a structure that positions a plurality of transducers in a spaced apart distribution, and a memory device system communicatively connected to the data processing device system and storing a program executable by the data processing device system. The data processing device system is configured by the program at least to cause the input-output device system to display a graphical representation of at least a portion of the transducer-based device, the graphical representation including a plurality of transducer graphical elements and a plurality of between graphical elements. Each of the transducer graphical elements is associated with a respective transducer of the plurality of transducers of the transducer-based device, and each of the between graphical elements is associated with a region of space between a pair of the transducers in the spaced apart distribution, each region of space not including any transducer, and no two of the pairs of the transducers having an identical pair of the transducers. The plurality of transducer graphical elements and at least a portion of the plurality of between graphical elements are arranged in a plurality of rows and a plurality of columns. The transducer graphical elements and the between graphical elements in each respective one of the plurality of rows are interleaved with respect to one another along the respective one of the plurality of rows. The transducer graphical elements and the between graphical elements in each respective one of the plurality of columns are interleaved with respect to one another along the respective one of the plurality of columns. Each one of the plurality of columns shares a same transducer graphical element with one of the plurality of rows. The data processing device system is further configured by the program at least to receive independent selections from the input-output device system of each of at least two of the plurality of between graphical elements, and cause, in response to receiving the independent selections, the graphical representation to include, during a time interval that occurs (a) during the receiving of the independent selections, (b) after a completion of the receiving of the independent selections, or both (a) and (b), a displayed visual representation of a path passing through at least a portion of each of the selected between graphical elements, the displayed visual representation of the path extending between at least two of the plurality of rows and between at least two of the plurality of columns.

In some embodiments, a transducer-activation method is executed by a data processing device system according to a program stored by a memory device system communicatively connected to the data processing device system. The data processing device system is further communicatively connected to an input-output device system. The input-output device system includes a transducer-based device, at least part of the transducer-based device positionable within a bodily cavity, and the transducer-based device includes a structure that positions a plurality of transducers in a spaced

apart distribution. The method may be summarized as including causing the input-output device system to display a graphical representation of at least a portion of the transducer-based device, the graphical representation including a plurality of transducer graphical elements and a plurality of between graphical elements. Each of the transducer graphical elements is associated with a respective transducer of the plurality of transducers of the transducer-based device, and each of the between graphical elements is associated with a region of space between a pair of the transducers in the spaced apart distribution, each region of space not including any transducer, and no two of the pairs of the transducers having an identical pair of the transducers. The plurality of transducer graphical elements and at least a portion of the plurality of between graphical elements are arranged in a plurality of rows and a plurality of columns. The transducer graphical elements and the between graphical elements in each respective one of the plurality of rows are interleaved with respect to one another along the respective one of the plurality of rows. The transducer graphical elements and the between graphical elements in each respective one of the plurality of columns are interleaved with respect to one another along the respective one of the plurality of columns. Each one of the plurality of columns shares a same transducer graphical element with one of the plurality of rows. The method further includes receiving independent selections from the input-output device system of each of at least two of the plurality of between graphical elements, and causing, in response to receiving the independent selections, the graphical representation to include, during a time interval that occurs (a) during the receiving of the independent selections, (b) after a completion of the receiving of the independent selections, or both (a) and (b), a displayed visual representation of a path passing through at least a portion of each of the selected between graphical elements, the displayed visual representation of the path extending between at least two of the plurality of rows and between at least two of the plurality of columns.

In some embodiments, a computer-readable storage medium system may be summarized as including one or more computer-readable storage mediums storing a program executable by one or more data processing devices of a data processing device system communicatively connected to an input-output device system. The input-output device system includes a transducer-based device, at least part of the transducer-based device positionable within a bodily cavity. The transducer-based device includes a structure that positions a plurality of transducers in a spaced apart distribution. The program includes a graphical representation module configured to cause the input-output device system to display a graphical representation of at least a portion of the transducer-based device. The graphical representation includes a plurality of transducer graphical elements and a plurality of between graphical elements. Each of the transducer graphical elements is associated with a respective transducer of the plurality of transducers of the transducer-based device, and each of the between graphical elements is associated with a region of space between a pair of the transducers in the spaced apart distribution, each region of space not including any transducer, and no two of the pairs of the transducers having an identical pair of the transducers. The plurality of transducer graphical elements and at least a portion of the plurality of between graphical elements are arranged in a plurality of rows and a plurality of columns. The transducer graphical elements and the between graphical elements in each respective one of the plurality of rows are interleaved with respect to one another along the respective one of the plurality of rows. The transducer graphical elements and the between graphical

elements in each respective one of the plurality of columns are interleaved with respect to one another along the respective one of the plurality of columns. Each one of the plurality of columns shares a same transducer graphical element with one of the plurality of rows. The program further includes a selection module configured to cause reception of independent selections from the input-output device system of each of at least two of the plurality of between graphical elements, and a path-display module configured to, in response to receiving the independent selections, cause the graphical representation to include, during a time interval that occurs (a) during the receiving of the independent selections, (b) after a completion of the receiving of the independent selections, or both (a) and (b), a displayed visual representation of a path passing through at least a portion of each of the selected between graphical elements, the displayed visual representation of the path extending between at least two of the plurality of rows and between at least two of the plurality of columns. In some embodiments, the computer-readable storage medium system is a non-transitory computer-readable storage medium system including one or more non-transitory computer-readable storage mediums storing the program.

In some embodiments, a transducer-selection system may be summarized as including a data processing device system, an input-output device system communicatively connected to the data processing device system, and a memory device system communicatively connected to the data processing device system and storing a program executable by the data processing device system. The program includes input instructions configured to cause reception of transducer data via the input-output device system, the transducer data indicating data acquired by at least some of a plurality of transducers included in a transducer-based device, at least part of the transducer-based device positionable within a bodily cavity. The program includes graphical representation instructions configured to cause the input-output device system to display a graphical representation, the graphical representation including a plurality of transducer graphical elements respectively associated with the plurality of transducers of the transducer-based device. The program includes identification instructions configured to cause identification of a region of the graphical representation that corresponds to at least a portion of an anatomical feature based at least on an analysis of the transducer data, wherein the graphical representation instructions are configured to cause the input-output device system to visually display the identified region of the graphical representation. The program further includes selection instructions configured to cause reception of a selection from the input-output device system of the visually-displayed identified region, and path-display instructions configured to, in response to receiving the selection, cause the displayed graphical representation to include a displayed visual representation of an ablation path configured for the anatomical feature.

The displayed visual representation of the ablation path may surround the identified region in the graphical representation. The displayed visual representation of the ablation path may continuously surround the identified region in the graphical representation. The transducer-based device may be a catheter device, and the anatomical feature may be an anatomical feature that forms at least part of the bodily cavity. The bodily cavity may include a tissue wall surface interrupted by one or more ports in fluid communication with the bodily cavity, and the anatomical feature may include at least one port of the one or more ports.

The plurality of transducers may be arranged in a distribution, the plurality of transducers positionable within a bodily

cavity. The transducer data may include data associated with an electrical characteristic of tissue in the bodily cavity. The electrical characteristic may be an electrical impedance of the tissue in the bodily cavity. The transducer data may include data associated with a flow characteristic of fluid in the bodily cavity.

The displayed visual representation of the ablation path may pass through a number of locations in the graphical representation, each of the number of locations positioned in the graphical representation at least proximate a respective one of at least some of the plurality of transducer graphical elements. The graphical representation instructions may include instructions configured to, in response to receiving the selection, cause the input-output device system to vary a visual characteristic of each of the at least some of the plurality of transducer graphical elements. The program may further include path-acceptance instructions configured to cause the data processing device system to receive an acceptance of the visual representation of the ablation path based at least on a user response communicated via the input-output device system. The program may further include activation instructions configured to, in response to receiving the acceptance, cause energy from an energy source device system to be delivered to each of the transducers associated with the at least some of the plurality of transducer graphical elements, the energy sufficient for ablating tissue.

The graphical representation may include a plurality of between graphical elements, each between graphical element associated with a region of space between a respective pair of the plurality of transducers, each region of space not including any transducer, and no two of the respective pairs of the plurality of transducers having an identical pair of the transducers. The graphical representation instructions may include instructions configured to, in response to receiving the selection, cause the input-output device system to vary a visual characteristic of each of at least some of the plurality of between graphical elements. The displayed visual representation of the ablation path may pass through each of the at least some of the plurality of between graphical elements. The program may further include path-acceptance instructions configured to cause reception of an acceptance of the visual representation of the ablation path based at least on a user response via the input-output device system, and activation instructions configured to, in response to receiving the acceptance, cause energy from an energy source device system to be delivered to each of the corresponding pairs of the plurality of transducers associated with each of the at least some of the plurality of between graphical elements, the energy sufficient for ablating tissue.

Various systems may include combinations and subsets of all those summarized above.

In some embodiments, a transducer-activation system includes a data processing device system, an input-output device system communicatively connected to the data processing device system, and a memory device system communicatively connected to the data processing device system and storing a program executable by the data processing device system. The data processing device system is configured by the program at least to receive transducer data via the input-output device system, the transducer data indicating data acquired by at least some of a plurality of transducers included in a transducer-based device, at least part of the transducer-based device positionable within a bodily cavity. The data processing device system is configured by the program at least to cause the input-output device system to display a graphical representation, the graphical representation including a plurality of transducer graphical elements respec-

tively associated with the plurality of transducers of the transducer-based device. The data processing device system is configured by the program at least to identify a region of the graphical representation that corresponds to at least a portion of an anatomical feature based at least on an analysis of the transducer data. The data processing device system is configured by the program at least to cause the input-output device system to visually display the identified region of the graphical representation. The data processing device system is configured by the program at least to receive a selection from the input-output device system of the visually-displayed identified region, and cause, in response to receiving the selection, the displayed graphical representation to include a displayed visual representation of an ablation path configured for the anatomical feature.

In some example embodiments a transducer-activation method is executed by a data processing device system according to a program stored by a memory device system communicatively connected to the data processing device system, the data processing device system further communicatively connected to an input-output device system. The method may be summarized as including receiving transducer data via the input-output device system, the transducer data indicating data acquired by at least some of a plurality of transducers included in a transducer-based device, at least part of the transducer-based device positionable within a bodily cavity. The method includes causing the input-output device system to display a graphical representation, the graphical representation including a plurality of transducer graphical elements respectively associated with the plurality of transducers of the transducer-based device. The method includes identifying a region of the graphical representation that corresponds to at least a portion of an anatomical feature based at least on an analysis of the transducer data. The method includes causing the input-output device system to visually display the identified region of the graphical representation. The method further includes receiving a selection from the input-output device system of the visually-displayed identified region, and causing, in response to receiving the selection, the displayed graphical representation to include a displayed visual representation of an ablation path configured for the anatomical feature.

In some embodiments, a computer-readable storage medium system may be summarized as including one or more computer-readable storage mediums storing a program executable by one or more data processing devices of a data processing device system communicatively connected to an input-output device system. The program includes an input module configured to cause reception of transducer data via the input-output device system, the transducer data indicating data acquired by at least some of a plurality of transducers included in a transducer-based device, at least part of the transducer-based device positionable within a bodily cavity. The program includes a graphical representation module configured to cause the input-output device system to display a graphical representation, the graphical representation including a plurality of transducer graphical elements respectively associated with the plurality of transducers of the transducer-based device. The program further includes an identification module configured to cause identification of a region of the graphical representation that corresponds to at least a portion of an anatomical feature based at least on an analysis of the transducer data. The graphical representation module is configured to cause the input-output device system to visually display the identified region of the graphical representation. The program further includes a selection module configured to cause reception of a selection from the input-output device

system of the visually-displayed identified region, and a path-display module configured to, in response to receiving the selection, cause the displayed graphical representation to include a displayed visual representation of an ablation path configured for the anatomical feature. In some embodiments, the computer-readable storage medium system is a non-transitory computer-readable storage medium system including one or more non-transitory computer-readable storage mediums storing the program.

A transducer-activation system may be summarized as including a data processing device system, an input-output device system communicatively connected to the data processing device system, and a memory device system communicatively connected to the data processing device system and storing a program executable by the data processing device system. The program includes graphical representation instructions configured to cause the input-output device system to display a graphical representation of at least a portion of a transducer-based device, at least part of the transducer-based device positionable within a bodily cavity. The graphical representation includes a between graphical element associated with a region of space between a first transducer and a second transducer of the transducer-based device, the region of space not including any transducer. The program includes activation instructions configured to cause, via the input-output device system, an energy source device system connected to at least the first transducer and the second transducer to deliver energy to each of the first transducer and the second transducer. The program includes determination instructions configured to cause determination of an energy-delivery status associated with at least one of the first transducer and the second transducer, the energy-delivery status indicating a status of the energy delivery by the energy source device system to the at least one of the first transducer and the second transducer. The program further includes energy-delivery-indication instructions configured to cause the input-output device system to change a displayed visual characteristic of the between graphical element based at least on the determined energy-delivery status of the at least one of the first transducer and the second transducer. The region of space may not be associated with any physical part of the transducer-based device.

The energy-delivery status associated with the at least one of the first transducer and the second transducer may include a pre-energy-delivery status associated with a state before a start of the energy delivery by the energy source device system to the at least one of the first transducer and the second transducer and a during-energy-delivery status associated with a state during the energy delivery by the energy source device system to the at least one of the first transducer and the second transducer. A first displayed visual characteristic of the between graphical element may be associated with the pre-energy-delivery status and a second displayed visual characteristic of the between graphical element may be associated with the during-energy-delivery status, the second displayed visual characteristic being different than the first displayed visual characteristic. The energy-delivery status associated with the at least one of the first transducer and the second transducer may include a post-energy-delivery status associated with a state after a completion of the energy delivery by the energy source device system to the at least one of the first transducer and the second transducer. A third displayed visual characteristic of the between graphical element may be associated with the post-energy delivery status, the third displayed visual characteristic being different than one of the first displayed visual characteristic and the second displayed visual characteristic. The third displayed visual

characteristic may be different than the first displayed visual characteristic, the second displayed visual characteristic, or both the first displayed visual characteristic and the second displayed visual characteristic.

The graphical representation may include a first transducer graphical element associated with the first transducer and a second transducer graphical element associated with the second transducer. The energy-delivery-indication instructions may be further configured to cause the input-output device system to change a displayed visual characteristic of the first transducer graphical element, the second transducer graphical element, or both the first transducer graphical element and the second transducer graphical element based at least on the determined energy-delivery status associated with the at least one of the first transducer and the second transducer. The graphical representation may include a first spatial relationship between the first transducer graphical element and the second transducer graphical element that is consistent with a second spatial relationship between the corresponding first transducer and the second transducer of the transducer-based device. The graphical representation instructions may be further configured to display the second transducer graphical element in a first direction from the first transducer graphical element. The between graphical element may be between the second transducer graphical element and the first transducer graphical element in the graphical representation. The between graphical element may be formed, at least in part, at a location in the graphical representation intersected by the first direction from the first transducer graphical element. The between graphical element may include an elongate portion extending along the first direction.

The input-output device system may include the transducer-based device. The transducer-based device may be a catheter device. The bodily cavity may be an intra-cardiac cavity.

Various systems may include combinations and subsets of all those summarized above.

In some embodiments, a transducer-activation system may be summarized as including a data processing device system, an input-output device system communicatively connected to the data processing device system, and a memory device system communicatively connected to the data processing device system and storing a program executable by the data processing device system. The data processing device system is configured by the program at least to cause the input-output device system to display a graphical representation of at least a portion of a transducer-based device, at least part of the transducer-based device positionable within a bodily cavity, and the graphical representation including a between graphical element associated with a region of space between a first transducer and a second transducer of the transducer-based device, the region of space not including any transducer. The data processing device system is configured by the program at least to cause the input-output device system to cause, via the input-output device system, an energy source device system connected to at least the first transducer and the second transducer to deliver energy to each of the first transducer and the second transducer. The data processing device system is configured by the program at least to cause the input-output device system to determine an energy-delivery status associated with at least one of the first transducer and the second transducer, the energy-delivery status indicating a status of the energy delivery by the energy source device system to the at least one of the first transducer and the second transducer. The data processing device system is further configured by the program at least to cause the input-output device system to change a displayed

visual characteristic of the between graphical element based at least on the determined energy-delivery status of the at least one of the first transducer and the second transducer.

In some embodiments, a transducer-activation method is executed by a data processing device system according to a program stored by a memory device system communicatively connected to the data processing device system, the data processing device system further communicatively connected to an input-output device system. The method may be summarized as including causing the input-output device system to display a graphical representation of at least a portion of a transducer-based device, at least part of the transducer-based device positionable within a bodily cavity, and the graphical representation including a between graphical element associated with a region of space between a first transducer and a second transducer of the transducer-based device, the region of space not including any transducer. The method includes causing, via the input-output device system, an energy source device system connected to at least the first transducer and the second transducer to deliver energy to each of the first transducer and the second transducer. The method includes determining an energy-delivery status associated with at least one of the first transducer and the second transducer, the energy-delivery status indicating a status of the energy delivery by the energy source device system to the at least one of the first transducer and the second transducer. The method further includes causing the input-output device system to change a displayed visual characteristic of the between graphical element based at least on the determined energy-delivery status of the at least one of the first transducer and the second transducer.

In some embodiments, a computer-readable storage medium system may be summarized as including one or more computer-readable storage mediums storing a program executable by one or more data processing devices of a data processing device system communicatively connected to an input-output device system. The program includes a graphical representation module configured to cause the input-output device system to display a graphical representation of at least a portion of a transducer-based device, at least part of the transducer-based device positionable within a bodily cavity. The graphical representation includes a between graphical element associated with a region of space between a first transducer and a second transducer of the transducer-based device, the region of space not including any transducer. The program includes an activation module configured to cause, via the input-output device system, an energy source device system connected to at least the first transducer and the second transducer to deliver energy to each of the first transducer and the second transducer. The program includes a determination module configured to cause determination of an energy-delivery status associated with at least one of the first transducer and the second transducer, the energy-delivery status indicating a status of the energy delivery by the energy source device system to the at least one of the first transducer and the second transducer. The program further includes an energy-delivery-indication module configured to cause the input-output device system to change a displayed visual characteristic of the between graphical element based at least on the determined energy-delivery status of the at least one of the first transducer and the second transducer. In some embodiments, the computer-readable storage medium system is a non-transitory computer-readable storage medium system including one or more non-transitory computer-readable storage mediums storing the program.

In some embodiments, a transducer-selection system may be summarized as including a data processing device system,

an input-output device system communicatively connected to the data processing device system, and a memory device system communicatively connected to the data processing device system and storing a program executable by the data processing device system. The program includes display instructions configured to cause the input-output device system to display a graphical representation of at least a portion of a transducer-based device, the transducer-based device including a structure and a plurality of transducers located on the structure, the plurality of transducers arranged in a distribution positionable in a bodily cavity. The graphical representation includes a plurality of graphical element sets, each graphical element set including one or more graphical elements and each graphical element set associated with a respective one of a plurality of pairs of adjacent ones of the transducers in the distribution, no two of the pairs of adjacent ones of the transducers in the distribution having an identical pair of adjacent ones of the transducers in the distribution. The program includes identification instructions configured to cause identification of which of the respective transducers of each of the pairs of adjacent ones of the transducers in the distribution are and which are not acceptable for concurrent selection. The display instructions are configured to cause the input-output device system to display each of the graphical element sets associated with each of the pairs of adjacent ones of the transducers in the distribution whose respective transducers have been identified, according to the identification instructions, to be acceptable for concurrent selection with a respective set of visual characteristics that distinguishes each of the graphical element sets associated with each of the pairs of adjacent ones of the transducers in the distribution whose respective transducers have been identified, according to the identification instructions, to be acceptable for concurrent selection from each of the graphical element sets associated with each of the pairs of adjacent ones of the transducers in the distribution whose respective transducers have been identified, according to the identification instructions, to be acceptable for concurrent selection.

The program may further include first selection instructions configured to cause selection of at least one graphical element in a first set of the plurality of graphical element sets that is associated with a first pair of the plurality of pairs of adjacent ones of the transducers in the distribution whose respective transducers have been identified, according to the identification instructions, to be acceptable for concurrent selection, and to cause concurrent selection, in response to the selection of the at least one graphical element in the first set of the plurality of graphical element sets, of the respective transducers of the first pair of the plurality of pairs of adjacent ones of the transducers in the distribution. The selection of the at least one graphical element in the first set of the plurality of graphical element sets may include a selection of a particular graphical element in the first set of the plurality of graphical element sets made in response to a user instruction to select a user-selected graphical element in the first set of the plurality of graphical element sets. The program may further include activation instructions configured to, in response to the concurrent selection, cause concurrent activation, via the input-output device system, of each of the respective transducers of the first pair of the plurality of pairs of adjacent ones of the transducers in the distribution. The activation instructions may be configured to, in response to the concurrent selection, cause monopolar activation, via the input-output device system, of each of the respective transducers of the first pair of the plurality of pairs of adjacent ones of the transducers in the distribution. The input-output device system may include the transducer-based device and an energy source device system

connected to each of the respective transducers of the first pair of the plurality of pairs of adjacent ones of the transducers in the distribution, and the activation instructions may be further configured to cause energy from the energy source device system to be delivered, for the monopolar activation, to each of the respective transducers of the first pair of the plurality of pairs of adjacent ones of the transducers in the distribution, the energy sufficient to cause ablation of tissue in the bodily cavity. The energy may be sufficient to cause an electrophysiological activity conduction block in the tissue between the respective transducers of the first pair of the plurality of pairs of adjacent ones of the transducers in the distribution.

The input-output device system may include the transducer-based device. The bodily cavity may be an intra-cardiac cavity, and each respective transducer of the first pair of the plurality of pairs of adjacent ones of the transducers in the distribution may be configured to detect electrophysiological activity in the intra-cardiac cavity at a location at least proximate the respective transducer of the first pair of the plurality of pairs of adjacent ones of the transducers in the distribution. The program may further include instructions configured to, in response to the concurrent selection, cause generation of a combined electrogram based at least on input received via the input-output device system from both of the respective transducers of the first pair of the plurality of pairs of adjacent ones of the transducers in the distribution.

The program may further include activation instructions configured to, in response to the concurrent selection, cause bipolar activation, via the input-output device system, between each of the respective transducers of the first pair of the plurality of pairs of adjacent ones of the transducers in the distribution. The input-output device system may include the transducer-based device and an energy source device system connected to each of the respective transducers of the first pair of the plurality of pairs of adjacent ones of the transducers in the distribution. The program may further include activation instructions configured to, in response to the concurrent selection, cause energy from the energy source device system to be delivered to each of the respective transducers of the first pair of the plurality of pairs of adjacent ones of the transducers in the distribution in a manner that, (a) a portion of the energy delivered to a first transducer of the first pair of the plurality of pairs of adjacent ones of the transducers in the distribution is transmitted by the first transducer to a second transducer of the first pair of the plurality of pairs of adjacent ones of the transducers in the distribution, (b) a portion of the energy delivered to the second transducer is transmitted by the second transducer to the first transducer, or both (a) and (b).

The program may further include second selection instructions configured to cause selection of at least one graphical element in a second set of the plurality of graphical element sets that is associated with a second pair of the plurality of pairs of adjacent ones of the transducers in the distribution whose respective transducers have been identified, according to the identification instructions, to be not acceptable for concurrent selection, and to cause non-concurrent selection, in response to the selection of the at least one graphical element in the second set of the plurality of graphical element sets, of the respective transducers of the second pair of the plurality of pairs of adjacent ones of the transducers in the distribution. The first and the second pairs of the plurality of pairs of adjacent ones of the transducers in the distribution may share a same transducer in the distribution. The selection of the at least one graphical element in the first set of the plurality of graphical element sets may be a selection, at one time, of each of the at least one graphical element in the first

set of the plurality of graphical element sets, and the selection of the at least one graphical element in the second set of the plurality of graphical element sets may be a selection, over a time interval, of at least two of the graphical elements in the second set of the plurality of graphical element sets. The second set of the plurality of graphical element sets may have a different number of graphical elements than the first set of the plurality of graphical element sets.

The program may further include third selection instructions configured to, (a) in response to receiving a user instruction to select at least a first user-selected graphical element in the first graphical element set, cause the data processing device system to select at least a second graphical element in the first graphical element set, (b) in response to receiving a user instruction to select at least a first user-selected graphical element in the second graphical element set, cause the data processing device system to select at least a second graphical element in the second graphical element set, or both (a) and (b). The program may further include second activation instructions configured to, in response to the non-concurrent selection, cause activation, via the input-output device system, of each of the respective transducers of the second pair of the plurality of pairs of adjacent ones of the transducers in the distribution, the second activation instructions configured to preclude bipolar activation between each of the respective transducers of the second pair of the plurality of pairs of adjacent ones of the transducers in the distribution. The program may further include second activation instructions configured to, in response to the non-concurrent selection, cause non-concurrent activation, via the input-output device system, of each of the respective transducers of the second pair of the plurality of pairs of adjacent ones of the transducers in the distribution.

The graphical representation may include a plurality of transducer graphical elements and one or more between graphical elements, each transducer graphical element associated with a corresponding transducer in the distribution, and each between graphical element associated with a region of space located between the transducers of a corresponding pair of the plurality of pairs of adjacent ones of the transducers in the distribution, the region of space not including any transducer. In some embodiments, none of the plurality of graphical element sets respectively associated with the pairs of adjacent ones of the transducers in the distribution whose respective transducers have been identified, according to the identification instructions, to be not acceptable for concurrent selection include any of the one or more between graphical elements. The region of space associated with at least a first between graphical element of the one or more between graphical elements may not be associated with any physical part of the transducer-based device. The region of space associated with at least a second between graphical element of the one or more between graphical elements may be associated with a physical part of the transducer-based device. The graphical representation may include a first spatial relationship between the plurality of transducer graphical elements that is consistent with a second spatial relationship between the corresponding transducers in the distribution. Each of the one or more between graphical elements may be located in the graphical representation between a respective pair of the transducer graphical elements, each respective pair of the transducer graphical elements associated with a respective pair of adjacent ones of the transducers in the distribution whose respective transducers have been identified, according to the identification instructions, to be acceptable for concurrent selection.

The program may further include instructions configured to cause reception of transducer data via the input-output device system, the transducer data indicating data acquired by at least some of the plurality of transducers. The identification instructions may be further configured to cause, at least in part, the identification of the respective transducers of each of the pairs of adjacent ones of the transducers in the distribution which are acceptable for concurrent selection based at least on an analysis of the transducer data.

The respective transducers of each of the plurality of pairs of adjacent ones of the transducers in the distribution may be spaced with respect to one another across a corresponding region of space, each region of space not including any transducer. The program may further include determination instructions configured to cause determination, via input received from the input-output device system, of which of the regions of space are and which are not acceptable for activation of the corresponding respective transducers of each of the plurality of pairs of adjacent ones of the transducers in the distribution. The identification instructions may be further configured to cause, at least in part, the identification of the respective transducers of each of the pairs of adjacent ones of the transducers in the distribution which are acceptable for concurrent selection as the respective transducers of each of the plurality of pairs of adjacent ones of the transducers in the distribution whose corresponding regions of space have been determined, according to the determination instructions, to be acceptable for activation of the corresponding respective transducers, and cause identification, at least in part, of the respective transducers of each of the pairs of adjacent ones of the transducers in the distribution which are not acceptable for concurrent selection as the respective transducers of each of the plurality of pairs of adjacent ones of the transducers in the distribution whose corresponding regions of space have been determined, according to the determination instructions, to be not acceptable for activation of the corresponding respective transducers.

The program may further include determination instructions configured to cause, via input received from the input-output device system, identification of an activation-ready transducer of the transducer-based device as a transducer of the plurality of transducers that is deemed, based at least on the input, to be located within sufficient proximity to a region of space, the sufficient proximity deemed acceptable for ablation, and cause identification of a not-activation-ready transducer of the transducer-based device as a transducer of the plurality of transducers that is deemed, based at least on an analysis of the input, to not be located within sufficient proximity to a region of space, the sufficient proximity deemed acceptable for ablation. The identification instructions may be further configured to cause, at least in part, the identification of the respective transducers of each of the pairs of adjacent ones of the transducers in the distribution which are acceptable for concurrent selection as the respective transducers of each of the plurality of pairs of adjacent ones of the transducers in the distribution including only transducers which have been identified according to the determination instructions to be activation-ready transducers.

The respective transducers of each of the plurality of pairs of adjacent ones of the transducers in the distribution may be spaced with respect to one another by a respective transducer-to-transducer distance, and the identification instructions may be further configured to cause, at least in part, the identification of the respective transducers of each of the pairs of adjacent ones of the transducers in the distribution which are acceptable for concurrent selection as the respective transducers of each of the plurality of pairs of adjacent ones of the

transducers in the distribution whose respective transducer-to-transducer distance is not greater than a target transducer-to-transducer distance, and cause identification, at least in part, of the respective transducers of each of the pairs of adjacent ones of the transducers in the distribution which are not acceptable for concurrent selection as the respective transducers of each of the plurality of pairs of adjacent ones of the transducers in the distribution whose transducer-to-transducer distance are greater than the target transducer-to-transducer distance.

Various systems may include combinations and subsets of all those summarized above.

In some embodiments, a transducer-selection system may be summarized as including a data processing device system, an input-output device system communicatively connected to the data processing device system, and a memory device system communicatively connected to the data processing device system and storing a program executable by the data processing device system. The data processing device system is configured by the program to display, via the input-output device system, a graphical representation of at least a portion of a transducer-based device, the transducer-based device including a structure and a plurality of transducers located on the structure, the plurality of transducers arranged in a distribution positionable in a bodily cavity. The graphical representation includes a plurality of graphical element sets, each graphical element set including one or more graphical elements and each graphical element set associated with a respective one of a plurality of pairs of adjacent ones of the transducers in the distribution, no two of the pairs of adjacent ones of the transducers in the distribution having an identical pair of adjacent ones of the transducers in the distribution. The data processing device system is further configured by the program to identify which of the respective transducers of each of the pairs of adjacent ones of the transducers in the distribution are and which are not acceptable for concurrent selection, and display, via the input-output device system, each of the graphical element sets associated with each of the pairs of adjacent ones of the transducers in the distribution whose respective transducers have been identified to be acceptable for concurrent selection with a respective set of visual characteristics that distinguishes each of the graphical element sets associated with each of the pairs of adjacent ones of the transducers in the distribution whose respective transducers have been identified to be acceptable for concurrent selection from each of the graphical element sets associated with each of the pairs of adjacent ones of the transducers in the distribution whose respective transducers have been identified to be not acceptable for concurrent selection.

In some embodiments, a transducer-selection method is executed by a data processing device system according to a program stored by a memory device system communicatively connected to the data processing device system, the data processing device system further communicatively connected to an input-output device system. The method includes displaying, via the input-output device system, a graphical representation of at least a portion of a transducer-based device, the transducer-based device including a structure and a plurality of transducers located on the structure, the plurality of transducers arranged in a distribution positionable in a bodily cavity, and the graphical representation including a plurality of graphical element sets, each graphical element set including one or more graphical elements and each graphical element set associated with a respective one of a plurality of pairs of adjacent ones of the transducers in the distribution, no two of the pairs of adjacent ones of the transducers in the distribution having an identical pair of adjacent ones of the

transducers in the distribution. The method includes identifying which of the respective transducers of each of the pairs of adjacent ones of the transducers in the distribution are and which are not acceptable for concurrent selection. The method further includes displaying, via the input-output device system, each of the graphical element sets associated with each of the pairs of adjacent ones of the transducers in the distribution whose respective transducers have been identified to be acceptable for concurrent selection with a respective set of visual characteristics that distinguishes each of the graphical element sets associated with each of the pairs of adjacent ones of the transducers in the distribution whose respective transducers have been identified to be acceptable for concurrent selection from each of the graphical element sets associated with each of the pairs of adjacent ones of the transducers in the distribution whose respective transducers have been identified to be not acceptable for concurrent selection.

In some embodiments, a computer-readable storage medium system may be summarized as including one or more computer-readable storage mediums storing a program executable by one or more data processing devices of a data processing device system communicatively connected to an input-output device system. The program includes a display module configured to cause the input-output device system to display a graphical representation of at least a portion of a transducer-based device, the transducer-based device including a structure and a plurality of transducers located on the structure, the plurality of transducers arranged in a distribution positionable in a bodily cavity, and the graphical representation including a plurality of graphical element sets, each graphical element set including one or more graphical elements and each graphical element set associated with a respective one of a plurality of pairs of adjacent ones of the transducers in the distribution, no two of the pairs of adjacent ones of the transducers in the distribution having an identical pair of adjacent ones of the transducers in the distribution. The program further includes an identification module configured to cause identification of which of the respective transducers of each of the pairs of adjacent ones of the transducers in the distribution are and which are not acceptable for concurrent selection. The display module is configured to cause the input-output device system to display each of the graphical element sets associated with each of the pairs of adjacent ones of the transducers in the distribution whose respective transducers have been identified, according to the identification module, to be acceptable for concurrent selection with a respective set of visual characteristics that distinguishes each of the graphical element sets associated with each of the pairs of adjacent ones of the transducers in the distribution whose respective transducers have been identified, according to the identification module, to be acceptable for concurrent selection from each of the graphical element sets associated with each of the pairs of adjacent ones of the transducers in the distribution whose respective transducers have been identified, according to the identification module, to be not acceptable for concurrent selection. In some embodiments, the computer-readable storage medium system is a non-transitory computer-readable storage medium system including one or more non-transitory computer-readable storage mediums storing the program.

In some embodiments, a transducer-activation system may be summarized as including a data processing device system, an input-output device system communicatively connected to the data processing device system, and a memory device system communicatively connected to the data processing device system and storing a program executable by the data

processing device system. The program includes display instructions configured to cause the input-output device system to display a graphical representation of at least a portion of a transducer-based device, the transducer-based device including a structure and a plurality of transducers located on the structure, the plurality of transducers arranged in a distribution positionable in a bodily cavity. The graphical representation includes a plurality of graphical elements, the plurality of graphical elements including a group of transducer graphical elements, each transducer graphical element in the group corresponding to a respective one of the transducers in the distribution. The program further includes first selection instructions configured to cause a first selection from the plurality of graphical elements of at least one graphical element in a first graphical element set from the plurality of graphical elements and first activation instructions configured to, in response to the first selection, cause activation, via the input-output device system, of each transducer of a first pair of the transducers in the distribution, the first pair of the transducers in the distribution having a first transducer and a second transducer. The program further includes second selection instructions configured to cause a second selection from the plurality of graphical elements of at least one graphical element in a second graphical element set from the plurality of graphical elements, and second activation instructions configured to, in response to the second selection, cause activation, via the input-output device system, of each transducer of a second pair of the transducers in the distribution, the second pair of the transducers in the distribution having the first transducer and a third transducer. Each of the first, the second, and the third transducers are different transducers in the distribution, and the first selection does not include a selection of a user-selected transducer graphical element in the group made in response to a user instruction to select the user-selected transducer graphical element in the group.

The first selection may include a selection of a user-selected graphical element in the first graphical element set made in response to a user instruction to select the user-selected graphical element in the first graphical element set. The program may further include third selection instructions configured to, in response to receiving a user instruction to select at least one user-selected graphical element in the first graphical element set, cause the data processing device system to select at least a second graphical element of the plurality of graphical elements. The second graphical element may be a particular one of the transducer graphical elements in the group. The first activation instructions may be further configured to, in response to the selection of the at least the second graphical element, cause activation, via the input-output device system, of each transducer of the first pair of the transducers in the distribution. The display instructions may be further configured to, in response to the first selection, cause the input-output device system to change a visual characteristic of at least a portion of the second graphical element.

The second selection may include a selection of a user-selected graphical element in the second graphical element set made in response to a user instruction to select the user-selected graphical element in the second graphical element set. The third selection instructions may be configured to, in response to receiving a user instruction to select at least one user-selected graphical element in the second graphical element set, cause the data processing device system to select at least a third graphical element of the plurality of graphical elements. The third graphical element may be the second graphical element.

Each of the first selection and the second selection may not include a selection of a transducer graphical element in the

group made in response to a user instruction to select the transducer graphical element in the group. The second selection may include a selection of at least two transducer graphical elements in the group.

The first activation instructions may be further configured to, in response to the first selection, cause concurrent activation, via the input-output device system, of each transducer of the first pair of the transducers in the distribution. The second activation instructions may be configured to, in response to the second selection, cause non-concurrent activation, via the input-output device system, of each transducer of the second pair of the transducers in the distribution.

Each of the first and the second pairs of transducers in the distribution may be a respective pair of a plurality of pairs of adjacent ones of the transducers in the distribution. The plurality of graphical elements may include at least one between graphical element, each between graphical element associated with a region of space located between the transducers of a corresponding pair of the plurality of pairs of adjacent ones of the transducers in the distribution, the region of space not including any transducer. The first graphical element set, the second graphical element set, or each of both the first and the second graphical element sets may include one of the at least one between graphical element. The region of space associated with at least a first between graphical element of the at least one between graphical element may not be associated with any physical part of the transducer-based device. The region of space associated with at least a second between graphical element of the at least one between graphical element may be associated with a physical part of the transducer-based device.

The graphical representation may include a first spatial relationship between the plurality of transducer graphical elements that is consistent with a second spatial relationship between the corresponding ones of the transducers in the distribution.

Various systems may include combinations and subsets of all those summarized above.

In some embodiments, a transducer-activation system may be summarized as including a data processing device system, an input-output device system communicatively connected to the data processing device system, and a memory device system communicatively connected to the data processing device system and storing a program executable by the data processing device system. The data processing device system is configured by the program to display, via the input-output device system, a graphical representation of at least a portion of a transducer-based device, the transducer-based device including a structure and a plurality of transducers located on the structure, the plurality of transducers arranged in a distribution positionable in a bodily cavity. The graphical representation includes a plurality of graphical elements, the plurality of graphical elements including a group of transducer graphical elements, each transducer graphical element in the group corresponding to a respective one of the transducers in the distribution. The data processing device system is configured by the program to select, via a first selection from the plurality of graphical elements, at least one graphical element in a first graphical element set from the plurality of graphical elements and activate, in response to the first selection and via the input-output device system, each transducer of a first pair of the transducers in the distribution, the first pair of the transducers in the distribution having a first transducer and a second transducer. The data processing device system is configured by the program to select, via a second selection from the plurality of graphical elements, at least one graphical element in a second graphical element set from the plurality

of graphical elements, and activate, in response to the second selection and via the input-output device system, each transducer of a second pair of the transducers in the distribution, the second pair of the transducers in the distribution having the first transducer and a third transducer. Each of the first, the second, and the third transducers are different transducers in the distribution, and the first selection does not include a selection of a user-selected transducer graphical element in the group made in response to a user instruction to select the user-selected transducer graphical element in the group.

In some embodiments, a transducer-activation method is executed by a data processing device system according to a program stored by a memory device system communicatively connected to the data processing device system, the data processing device system further communicatively connected to an input-output device system. The method includes displaying, via the input-output device system, a graphical representation of at least a portion of a transducer-based device, the transducer-based device including a structure and a plurality of transducers located on the structure, the plurality of transducers arranged in a distribution positionable in a bodily cavity. The graphical representation includes a plurality of graphical elements, the plurality of graphical elements including a group of transducer graphical elements, each transducer graphical element in the group corresponding to a respective one of the transducers in the distribution. The method further includes selecting, via a first selection from the plurality of graphical elements, at least one graphical element in a first graphical element set from the plurality of graphical elements and activating, in response to the first selection and via the input-output device system, each transducer of a first pair of the transducers in the distribution, the first pair of the transducers in the distribution having a first transducer and a second transducer. The method further includes selecting, via a second selection from the plurality of graphical elements, at least one graphical element in a second graphical element set from the plurality of graphical elements, and activating, in response to the second selection and via the input-output device system, each transducer of a second pair of the transducers in the distribution, the second pair of the transducers in the distribution having the first transducer and a third transducer. Each of the first, the second, and the third transducers are different transducers in the distribution, and the first selection does not include a selection of a user-selected transducer graphical element in the group made in response to a user instruction to select the user-selected transducer graphical element in the group.

In some embodiments, a computer-readable storage medium system may be summarized as including one or more computer-readable storage mediums storing a program executable by one or more data processing devices of a data processing device system communicatively connected to an input-output device system. The program includes a display module configured to cause the input-output device system to display a graphical representation of at least a portion of a transducer-based device, the transducer-based device including a structure and a plurality of transducers located on the structure, the plurality of transducers arranged in a distribution positionable in a bodily cavity. The graphical representation includes a plurality of graphical elements, the plurality of graphical elements including a group of transducer graphical elements, each transducer graphical element in the group corresponding to a respective one of the transducers in the distribution. The program includes a first selection module configured to cause selection of a first selection from the plurality of graphical elements of at least one graphical element in a first graphical element set from the plurality of

graphical elements, and a first activation module configured to, in response to the first selection, cause activation, via the input-output device system, of each transducer of a first pair of the transducers in the distribution, the first pair of the transducers in the distribution having a first transducer and a second transducer. The program further includes a second selection module configured to cause selection of a second selection from the plurality of graphical elements of at least one graphical element in a second graphical element set from the plurality of graphical elements, and a second activation module configured to, in response to the second selection, cause activation, via the input-output device system, of each transducer of a second pair of the transducers in the distribution, the second pair of the transducers in the distribution having the first transducer and a third transducer. Each of the first, the second, and the third transducers are different transducers in the distribution, and the first selection does not include a selection of a user-selected transducer graphical element in the group made in response to a user instruction to select the user-selected transducer graphical element in the group. In some embodiments, the computer-readable storage medium system is a non-transitory computer-readable storage medium system including one or more non-transitory computer-readable storage mediums storing the program.

In some embodiments, a transducer-selection system may be summarized as including a data processing device system, an input-output device system communicatively connected to the data processing device system, and a memory device system communicatively connected to the data processing device system and storing a program executable by the data processing device system. The program includes display instructions configured to cause the input-output device system to display a graphical representation of at least a portion of a transducer-based device, the transducer-based device including a structure and a plurality of transducers located on the structure, the plurality of transducers arranged in a distribution positionable in a bodily cavity. The graphical representation includes a plurality of graphical element sets, each graphical element set including one or more graphical elements and each graphical element set associated with a respective one of a plurality of pairs of adjacent ones of the transducers in the distribution, no two of the pairs of adjacent ones of the transducers in the distribution having an identical pair of adjacent ones of the transducers in the distribution. The program includes identification instructions configured to cause identification of which of the respective transducers of each of the pairs of adjacent ones of the transducers in the distribution are and which are not acceptable for concurrent selection. The display instructions are configured to cause the input-output device system to display each of the graphical element sets associated with each of the pairs of adjacent ones of the transducers in the distribution whose respective transducers have been identified, according to the identification instructions, to be acceptable for concurrent selection with a respective set of visual characteristics that distinguishes each of the graphical element sets associated with each of the pairs of adjacent ones of the transducers in the distribution whose respective transducers have been identified, according to the identification instructions, to be acceptable for concurrent selection from each of the graphical element sets associated with each of the pairs of adjacent ones of the transducers in the distribution whose respective transducers have been identified, according to the identification instructions, to be not acceptable for concurrent selection.

The program may further include first selection instructions configured to cause selection of at least one graphical element in a first set of the plurality of graphical element sets

that is associated with a first pair of the plurality of pairs of adjacent ones of the transducers in the distribution whose respective transducers have been identified, according to the identification instructions, to be acceptable for concurrent selection, and to cause concurrent selection, in response to the selection of the at least one graphical element in the first set of the plurality of graphical element sets, of the respective transducers of the first pair of the plurality of pairs of adjacent ones of the transducers in the distribution. The selection of the at least one graphical element in the first set of the plurality of graphical element sets may include a selection of a particular graphical element in the first set of the plurality of graphical element sets made in response to a user instruction to select a user-selected graphical element in the first set of the plurality of graphical element sets. The program may further include activation instructions configured to, in response to the concurrent selection, cause concurrent activation, via the input-output device system, of each of the respective transducers of the first pair of the plurality of pairs of adjacent ones of the transducers in the distribution. The activation instructions may be configured to, in response to the concurrent selection, cause monopolar activation, via the input-output device system, of each of the respective transducers of the first pair of the plurality of pairs of adjacent ones of the transducers in the distribution. The input-output device system may include the transducer-based device and an energy source device system connected to each of the respective transducers of the first pair of the plurality of pairs of adjacent ones of the transducers in the distribution, and the activation instructions may be further configured to cause energy from the energy source device system to be delivered, for the monopolar activation, to each of the respective transducers of the first pair of the plurality of pairs of adjacent ones of the transducers in the distribution, the energy sufficient to cause ablation of tissue in the bodily cavity. The energy may be sufficient to cause an electrophysiological activity conduction block in the tissue between the respective transducers of the first pair of the plurality of pairs of adjacent ones of the transducers in the distribution.

The input-output device system may include the transducer-based device. The bodily cavity may be an intra-cardiac cavity, and each respective transducer of the first pair of the plurality of pairs of adjacent ones of the transducers in the distribution may be configured to detect electrophysiological activity in the intra-cardiac cavity at a location at least proximate the respective transducer of the first pair of the plurality of pairs of adjacent ones of the transducers in the distribution. The program may further include instructions configured to, in response to the concurrent selection, cause generation of a combined electrogram based at least on input received via the input-output device system from both of the respective transducers of the first pair of the plurality of pairs of adjacent ones of the transducers in the distribution.

The program may further include activation instructions configured to, in response to the concurrent selection, cause bipolar activation, via the input-output device system, between each of the respective transducers of the first pair of the plurality of pairs of adjacent ones of the transducers in the distribution. The input-output device system may include the transducer-based device and an energy source device system connected to each of the respective transducers of the first pair of the plurality of pairs of adjacent ones of the transducers in the distribution. The program may further include activation instructions configured to, in response to the concurrent selection, cause energy from the energy source device system to be delivered to each of the respective transducers of the first pair of the plurality of pairs of adjacent ones of the transducers in the distribution in a manner that, (a) a portion of the

energy delivered to a first transducer of the first pair of the plurality of pairs of adjacent ones of the transducers in the distribution is transmitted by the first transducer to a second transducer of the first pair of the plurality of pairs of adjacent ones of the transducers in the distribution, (b) a portion of the energy delivered to the second transducer is transmitted by the second transducer to the first transducer, or both (a) and (b).

The program may further include second selection instructions configured to cause selection of at least one graphical element in a second set of the plurality of graphical element sets that is associated with a second pair of the plurality of pairs of adjacent ones of the transducers in the distribution whose respective transducers have been identified, according to the identification instructions, to be not acceptable for concurrent selection, and to cause non-concurrent selection, in response to the selection of the at least one graphical element in the second set of the plurality of graphical element sets, of the respective transducers of the second pair of the plurality of pairs of adjacent ones of the transducers in the distribution. The first and the second pairs of the plurality of pairs of adjacent ones of the transducers in the distribution may share a same transducer in the distribution. The selection of the at least one graphical element in the first set of the plurality of graphical element sets may be a selection, at one time, of each of the at least one graphical element in the first set of the plurality of graphical element sets, and the selection of the at least one graphical element in the second set of the plurality of graphical element sets may be a selection, over a time interval, of at least two of the graphical elements in the second set of the plurality of graphical element sets. The second set of the plurality of graphical element sets may have a different number of graphical elements than the first set of the plurality of graphical element sets.

The program may further include third selection instructions configured to, (a) in response to receiving a user instruction to select at least a first user-selected graphical element in the first graphical element set, cause the data processing device system to select at least a second graphical element in the first graphical element set, (b) in response to receiving a user instruction to select at least a first user-selected graphical element in the second graphical element set, cause the data processing device system to select at least a second graphical element in the second graphical element set, or both (a) and (b). The program may further include second activation instructions configured to, in response to the non-concurrent selection, cause activation, via the input-output device system, of each of the respective transducers of the second pair of the plurality of pairs of adjacent ones of the transducers in the distribution, the second activation instructions configured to preclude bipolar activation between each of the respective transducers of the second pair of the plurality of pairs of adjacent ones of the transducers in the distribution. The program may further include second activation instructions configured to, in response to the non-concurrent selection, cause non-concurrent activation, via the input-output device system, of each of the respective transducers of the second pair of the plurality of pairs of adjacent ones of the transducers in the distribution.

The graphical representation may include a plurality of transducer graphical elements and one or more between graphical elements, each transducer graphical element associated with a corresponding transducer in the distribution, and each between graphical element associated with a region of space located between the transducers of a corresponding pair of the plurality of pairs of adjacent ones of the transducers in the distribution, the region of space not including any trans-

ducer. In some embodiments, none of the plurality of graphical element sets respectively associated with the pairs of adjacent ones of the transducers in the distribution whose respective transducers have been identified, according to the identification instructions, to be not acceptable for concurrent selection include any of the one or more between graphical elements. The region of space associated with at least a first between graphical element of the one or more between graphical elements may not be associated with any physical part of the transducer-based device. The region of space associated with at least a second between graphical element of the one or more between graphical elements may be associated with a physical part of the transducer-based device. The graphical representation may include a first spatial relationship between the plurality of transducer graphical elements that is consistent with a second spatial relationship between the corresponding transducers in the distribution. Each of the one or more between graphical elements may be located in the graphical representation between a respective pair of the transducer graphical elements, each respective pair of the transducer graphical elements associated with a respective pair of adjacent ones of the transducers in the distribution whose respective transducers have been identified, according to the identification instructions, to be acceptable for concurrent selection.

The program may further include instructions configured to cause reception of transducer data via the input-output device system, the transducer data indicating data acquired by at least some of the plurality of transducers. The identification instructions may be further configured to cause, at least in part, the identification of the respective transducers of each of the pairs of adjacent ones of the transducers in the distribution which are acceptable for concurrent selection based at least on an analysis of the transducer data.

The respective transducers of each of the plurality of pairs of adjacent ones of the transducers in the distribution may be spaced with respect to one another across a corresponding region of space, each region of space not including any transducer. The program may further include determination instructions configured to cause determination, via input received from the input-output device system, of which of the regions of space are and which are not acceptable for activation of the corresponding respective transducers of each of the plurality of pairs of adjacent ones of the transducers in the distribution. The identification instructions may be further configured to cause, at least in part, the identification of the respective transducers of each of the pairs of adjacent ones of the transducers in the distribution which are acceptable for concurrent selection as the respective transducers of each of the plurality of pairs of adjacent ones of the transducers in the distribution whose corresponding regions of space have been determined, according to the determination instructions, to be acceptable for activation of the corresponding respective transducers, and cause identification, at least in part, of the respective transducers of each of the pairs of adjacent ones of the transducers in the distribution which are not acceptable for concurrent selection as the respective transducers of each of the plurality of pairs of adjacent ones of the transducers in the distribution whose corresponding regions of space have been determined, according to the determination instructions, to be not acceptable for activation of the corresponding respective transducers.

The program may further include determination instructions configured to cause, via input received from the input-output device system, identification of an activation-ready transducer of the transducer-based device as a transducer of the plurality of transducers that is deemed, based at least on

the input, to be located within sufficient proximity to a region of space, the sufficient proximity deemed acceptable for ablation, and cause identification of a not-activation-ready transducer of the transducer-based device as a transducer of the plurality of transducers that is deemed, based at least on an analysis of the input, to not be located within sufficient proximity to a region of space, the sufficient proximity deemed acceptable for ablation. The identification instructions may be further configured to cause, at least in part, the identification of the respective transducers of each of the pairs of adjacent ones of the transducers in the distribution which are acceptable for concurrent selection as the respective transducers of each of the plurality of pairs of adjacent ones of the transducers in the distribution including only transducers which have been identified according to the determination instructions to be activation-ready transducers.

The respective transducers of each of the plurality of pairs of adjacent ones of the transducers in the distribution may be spaced with respect to one another by a respective transducer-to-transducer distance, and the identification instructions may be further configured to cause, at least in part, the identification of the respective transducers of each of the pairs of adjacent ones of the transducers in the distribution which are acceptable for concurrent selection as the respective transducers of each of the plurality of pairs of adjacent ones of the transducers in the distribution whose respective transducer-to-transducer distance is not greater than a target transducer-to-transducer distance, and cause identification, at least in part, of the respective transducers of each of the pairs of adjacent ones of the transducers in the distribution which are not acceptable for concurrent selection as the respective transducers of each of the plurality of pairs of adjacent ones of the transducers in the distribution whose transducer-to-transducer distance are greater than the target transducer-to-transducer distance.

Various systems may include combinations and subsets of all those summarized above.

In some embodiments, a transducer-selection system may be summarized as including a data processing device system, an input-output device system communicatively connected to the data processing device system, and a memory device system communicatively connected to the data processing device system and storing a program executable by the data processing device system. The data processing device system is configured by the program to display, via the input-output device system, a graphical representation of at least a portion of a transducer-based device, the transducer-based device including a structure and a plurality of transducers located on the structure, the plurality of transducers arranged in a distribution positionable in a bodily cavity. The graphical representation includes a plurality of graphical element sets, each graphical element set including one or more graphical elements and each graphical element set associated with a respective one of a plurality of pairs of adjacent ones of the transducers in the distribution, no two of the pairs of adjacent ones of the transducers in the distribution having an identical pair of adjacent ones of the transducers in the distribution. The data processing device system is further configured by the program to identify which of the respective transducers of each of the pairs of adjacent ones of the transducers in the distribution are and which are not acceptable for concurrent selection, and display, via the input-output device system, each of the graphical element sets associated with each of the pairs of adjacent ones of the transducers in the distribution whose respective transducers have been identified to be acceptable for concurrent selection with a respective set of visual characteristics that distinguishes each of the graphical

element sets associated with each of the pairs of adjacent ones of the transducers in the distribution whose respective transducers have been identified to be acceptable for concurrent selection from each of the graphical element sets associated with each of the pairs of adjacent ones of the transducers in the distribution whose respective transducers have been identified to be not acceptable for concurrent selection.

In some embodiments, a transducer-selection method is executed by a data processing device system according to a program stored by a memory device system communicatively connected to the data processing device system, the data processing device system further communicatively connected to an input-output device system. The method includes displaying, via the input-output device system, a graphical representation of at least a portion of a transducer-based device, the transducer-based device including a structure and a plurality of transducers located on the structure, the plurality of transducers arranged in a distribution positionable in a bodily cavity, and the graphical representation including a plurality of graphical element sets, each graphical element set including one or more graphical elements and each graphical element set associated with a respective one of a plurality of pairs of adjacent ones of the transducers in the distribution, no two of the pairs of adjacent ones of the transducers in the distribution having an identical pair of adjacent ones of the transducers in the distribution. The method includes identifying which of the respective transducers of each of the pairs of adjacent ones of the transducers in the distribution are and which are not acceptable for concurrent selection. The method further includes displaying, via the input-output device system, each of the graphical element sets associated with each of the pairs of adjacent ones of the transducers in the distribution whose respective transducers have been identified to be acceptable for concurrent selection with a respective set of visual characteristics that distinguishes each of the graphical element sets associated with each of the pairs of adjacent ones of the transducers in the distribution whose respective transducers have been identified to be acceptable for concurrent selection from each of the graphical element sets associated with each of the pairs of adjacent ones of the transducers in the distribution whose respective transducers have been identified to be not acceptable for concurrent selection.

In some embodiments, a computer-readable storage medium system may be summarized as including one or more computer-readable storage mediums storing a program executable by one or more data processing devices of a data processing device system communicatively connected to an input-output device system. The program includes a display module configured to cause the input-output device system to display a graphical representation of at least a portion of a transducer-based device, the transducer-based device including a structure and a plurality of transducers located on the structure, the plurality of transducers arranged in a distribution positionable in a bodily cavity, and the graphical representation including a plurality of graphical element sets, each graphical element set including one or more graphical elements and each graphical element set associated with a respective one of a plurality of pairs of adjacent ones of the transducers in the distribution, no two of the pairs of adjacent ones of the transducers in the distribution having an identical pair of adjacent ones of the transducers in the distribution. The program further includes an identification module configured to cause identification of which of the respective transducers of each of the pairs of adjacent ones of the transducers in the distribution are and which are not acceptable for concurrent selection. The display module is configured to

cause the input-output device system to display each of the graphical element sets associated with each of the pairs of adjacent ones of the transducers in the distribution whose respective transducers have been identified, according to the identification module, to be acceptable for concurrent selection with a respective set of visual characteristics that distinguishes each of the graphical element sets associated with each of the pairs of adjacent ones of the transducers in the distribution whose respective transducers have been identified, according to the identification module, to be acceptable for concurrent selection from each of the graphical element sets associated with each of the pairs of adjacent ones of the transducers in the distribution whose respective transducers have been identified, according to the identification module, to be not acceptable for concurrent selection. In some embodiments, the computer-readable storage medium system is a non-transitory computer-readable storage medium system including one or more non-transitory computer-readable storage mediums storing the program.

In some embodiments, a transducer-activation system may be summarized as including a data processing device system, an input-output device system communicatively connected to the data processing device system, and a memory device system communicatively connected to the data processing device system and storing a program executable by the data processing device system. The program includes display instructions configured to cause the input-output device system to display a graphical representation of at least a portion of a transducer-based device, the transducer-based device including a structure and a plurality of transducers located on the structure, the plurality of transducers arranged in a distribution positionable in a bodily cavity. The graphical representation includes a plurality of graphical elements, the plurality of graphical elements including a group of transducer graphical elements, each transducer graphical element in the group corresponding to a respective one of the transducers in the distribution. The program further includes first selection instructions configured to cause a first selection from the plurality of graphical elements of at least one graphical element in a first graphical element set from the plurality of graphical elements and first activation instructions configured to, in response to the first selection, cause activation, via the input-output device system, of each transducer of a first pair of the transducers in the distribution, the first pair of the transducers in the distribution having a first transducer and a second transducer. The program further includes second selection instructions configured to cause a second selection from the plurality of graphical elements of at least one graphical element in a second graphical element set from the plurality of graphical elements, and second activation instructions configured to, in response to the second selection, cause activation, via the input-output device system, of each transducer of a second pair of the transducers in the distribution, the second pair of the transducers in the distribution having the first transducer and a third transducer. Each of the first, the second, and the third transducers are different transducers in the distribution, and the first selection does not include a selection of a user-selected transducer graphical element in the group made in response to a user instruction to select the user-selected transducer graphical element in the group.

The first selection may include a selection of a user-selected graphical element in the first graphical element set made in response to a user instruction to select the user-selected graphical element in the first graphical element set. The program may further include third selection instructions configured to, in response to receiving a user instruction to select at least one user-selected graphical element in the first

graphical element set, cause the data processing device system to select at least a second graphical element of the plurality of graphical elements. The second graphical element may be a particular one of the transducer graphical elements in the group. The first activation instructions may be further configured to, in response to the selection of the at least the second graphical element, cause activation, via the input-output device system, of each transducer of the first pair of the transducers in the distribution. The display instructions may be further configured to, in response to the first selection, cause the input-output device system to change a visual characteristic of at least a portion of the second graphical element.

The second selection may include a selection of a user-selected graphical element in the second graphical element set made in response to a user instruction to select the user-selected graphical element in the second graphical element set. The third selection instructions may be configured to, in response to receiving a user instruction to select at least one user-selected graphical element in the second graphical element set, cause the data processing device system to select at least a third graphical element of the plurality of graphical elements. The third graphical element may be the second graphical element.

Each of the first selection and the second selection may not include a selection of a transducer graphical element in the group made in response to a user instruction to select the transducer graphical element in the group. The second selection may include a selection of at least two transducer graphical elements in the group.

The first activation instructions may be further configured to, in response to the first selection, cause concurrent activation, via the input-output device system, of each transducer of the first pair of the transducers in the distribution. The second activation instructions may be configured to, in response to the second selection, cause non-concurrent activation, via the input-output device system, of each transducer of the second pair of the transducers in the distribution.

Each of the first and the second pairs of transducers in the distribution may be a respective pair of a plurality of pairs of adjacent ones of the transducers in the distribution. The plurality of graphical elements may include at least one between graphical element, each between graphical element associated with a region of space located between the transducers of a corresponding pair of the plurality of pairs of adjacent ones of the transducers in the distribution, the region of space not including any transducer. The first graphical element set, the second graphical element set, or each of both the first and the second graphical element sets may include one of the at least one between graphical element. The region of space associated with at least a first between graphical element of the at least one between graphical element may not be associated with any physical part of the transducer-based device. The region of space associated with at least a second between graphical element of the at least one between graphical element may be associated with a physical part of the transducer-based device.

The graphical representation may include a first spatial relationship between the plurality of transducer graphical elements that is consistent with a second spatial relationship between the corresponding ones of the transducers in the distribution.

Various systems may include combinations and subsets of all those summarized above.

In some embodiments, a transducer-activation system may be summarized as including a data processing device system, an input-output device system communicatively connected to the data processing device system, and a memory device

system communicatively connected to the data processing device system and storing a program executable by the data processing device system. The data processing device system is configured by the program to display, via the input-output device system, a graphical representation of at least a portion of a transducer-based device, the transducer-based device including a structure and a plurality of transducers located on the structure, the plurality of transducers arranged in a distribution positionable in a bodily cavity. The graphical representation includes a plurality of graphical elements, the plurality of graphical elements including a group of transducer graphical elements, each transducer graphical element in the group corresponding to a respective one of the transducers in the distribution. The data processing device system is configured by the program to select, via a first selection from the plurality of graphical elements, at least one graphical element in a first graphical element set from the plurality of graphical elements and activate, in response to the first selection and via the input-output device system, each transducer of a first pair of the transducers in the distribution, the first pair of the transducers in the distribution having a first transducer and a second transducer. The data processing device system is configured by the program to select, via a second selection from the plurality of graphical elements, at least one graphical element in a second graphical element set from the plurality of graphical elements, and activate, in response to the second selection and via the input-output device system, each transducer of a second pair of the transducers in the distribution, the second pair of the transducers in the distribution having the first transducer and a third transducer. Each of the first, the second, and the third transducers are different transducers in the distribution, and the first selection does not include a selection of a user-selected transducer graphical element in the group made in response to a user instruction to select the user-selected transducer graphical element in the group.

In some embodiments, a transducer-activation method is executed by a data processing device system according to a program stored by a memory device system communicatively connected to the data processing device system, the data processing device system further communicatively connected to an input-output device system. The method includes displaying, via the input-output device system, a graphical representation of at least a portion of a transducer-based device, the transducer-based device including a structure and a plurality of transducers located on the structure, the plurality of transducers arranged in a distribution positionable in a bodily cavity. The graphical representation includes a plurality of graphical elements, the plurality of graphical elements including a group of transducer graphical elements, each transducer graphical element in the group corresponding to a respective one of the transducers in the distribution. The method further includes selecting, via a first selection from the plurality of graphical elements, at least one graphical element in a first graphical element set from the plurality of graphical elements and activating, in response to the first selection and via the input-output device system, each transducer of a first pair of the transducers in the distribution, the first pair of the transducers in the distribution having a first transducer and a second transducer. The method further includes selecting, via a second selection from the plurality of graphical elements, at least one graphical element in a second graphical element set from the plurality of graphical elements, and activating, in response to the second selection and via the input-output device system, each transducer of a second pair of the transducers in the distribution, the second pair of the transducers in the distribution having the first transducer and a third transducer. Each of the first, the second, and

the third transducers are different transducers in the distribution, and the first selection does not include a selection of a user-selected transducer graphical element in the group made in response to a user instruction to select the user-selected transducer graphical element in the group.

In some embodiments, a computer-readable storage medium system may be summarized as including one or more computer-readable storage mediums storing a program executable by one or more data processing devices of a data processing device system communicatively connected to an input-output device system. The program includes a display module configured to cause the input-output device system to display a graphical representation of at least a portion of a transducer-based device, the transducer-based device including a structure and a plurality of transducers located on the structure, the plurality of transducers arranged in a distribution positionable in a bodily cavity. The graphical representation includes a plurality of graphical elements, the plurality of graphical elements including a group of transducer graphical elements, each transducer graphical element in the group corresponding to a respective one of the transducers in the distribution. The program includes a first selection module configured to cause selection of a first selection from the plurality of graphical elements of at least one graphical element in a first graphical element set from the plurality of graphical elements, and a first activation module configured to, in response to the first selection, cause activation, via the input-output device system, of each transducer of a first pair of the transducers in the distribution, the first pair of the transducers in the distribution having a first transducer and a second transducer. The program further includes a second selection module configured to cause selection of a second selection from the plurality of graphical elements of at least one graphical element in a second graphical element set from the plurality of graphical elements, and a second activation module configured to, in response to the second selection, cause activation, via the input-output device system, of each transducer of a second pair of the transducers in the distribution, the second pair of the transducers in the distribution having the first transducer and a third transducer. Each of the first, the second, and the third transducers are different transducers in the distribution, and the first selection does not include a selection of a user-selected transducer graphical element in the group made in response to a user instruction to select the user-selected transducer graphical element in the group. In some embodiments, the computer-readable storage medium system is a non-transitory computer-readable storage medium system including one or more non-transitory computer-readable storage mediums storing the program.

Various systems may include combinations and subsets of all the systems summarized above. Various methods may include combinations and subsets of all the methods summarized above.

BRIEF DESCRIPTION OF THE DRAWINGS

It is to be understood that the attached drawings are for purposes of illustrating aspects of various embodiments and may include elements that are not to scale.

FIG. 1 illustrates a schematic representation of a transducer-activation system according to various example embodiments, the transducer-activation system including a data processing device system, an input-output device system, and a memory device system.

FIG. 2 illustrates a cutaway diagram of a heart showing a transducer-based device percutaneously placed in a left atrium of the heart according to various example embodiments.

FIG. 3A illustrates a partially schematic representation of a medical system according to various example embodiments, the medical system including a data processing device system, an input-output device system, a memory device system, and a transducer-based device having a plurality of transducers and an expandable structure shown in a delivery or unexpanded configuration.

FIG. 3B illustrates the representation of the medical system of FIG. 3A with the expandable structure shown in a deployed or expanded configuration.

FIG. 4 illustrates a schematic representation of a transducer-based device that includes a flexible circuit structure according to various example embodiments.

FIG. 5A illustrates a graphical interface providing a graphical representation of at least a portion of a transducer-based device according to various example embodiments, the graphical representation including a plurality of graphical elements including a plurality of transducer graphical elements and a plurality of between graphical elements.

FIG. 5B illustrates the graphical representation provided by the graphical interface of FIG. 5A with at least some of the transducer graphical elements identified by identification labels.

FIG. 5C illustrates the graphical representation provided by the graphical interface of FIG. 5A with the addition of various regions determined based at least on an analysis of transducer data.

FIG. 5D illustrates the graphical representation of FIG. 5C depicted two-dimensionally.

FIG. 5E illustrates the graphical representation of FIG. 5C with a graphical element selected in accordance with various example embodiments.

FIG. 5F illustrates the graphical representation of FIG. 5C with an addition of a depicted path.

FIGS. 5G and 5H illustrate the graphical representation of FIG. 5F associated with two successive activations of various transducer sets selected according to a first sequence but activated according to a second sequence different from the first sequence.

FIG. 5I illustrates the graphical representation of FIG. 5F after the completion of the activation of all the various transducer sets according to the second sequence.

FIG. 5J illustrates a graphical interface providing a graphical representation of at least a portion of a transducer-based device according to various example embodiments.

FIG. 6 illustrates a graphical interface providing a graphical representation of at least a portion of a transducer-based device according to various example embodiments.

FIG. 7A illustrates a block diagram of a method for activating transducers of a transducer-based device according to some example embodiments.

FIG. 7B illustrates an exploded view of some of the blocks of the block diagram of FIG. 7A according to some example embodiments.

FIG. 8 illustrates a block diagram of a method for activating transducers of a transducer-based device according to various example embodiments.

FIG. 9 illustrates a block diagram of a method for displaying a visual representation of an ablation path according to various example embodiments.

FIG. 10 illustrates an exploded view of some of the blocks of the block diagram of FIG. 8, according to some example embodiments.

In the following description, certain specific details are set forth in order to provide a thorough understanding of various embodiments of the invention. However, one skilled in the art will understand that the invention may be practiced without these details. In other instances, well-known structures (e.g., structures associated with radio-frequency (RF) ablation and electronic controls such as multiplexers) have not been shown or described in detail to avoid unnecessarily obscuring descriptions of various embodiments of the invention.

Reference throughout this specification to “one embodiment” or “an embodiment” or “an example embodiment” or “an illustrated embodiment” or “a particular embodiment” and the like means that a particular feature, structure or characteristic described in connection with the embodiment is included in at least one embodiment. Thus, the appearances of the phrases “in one embodiment” or “in an embodiment” or “in an example embodiment” or “in this illustrated embodiment” or “in this particular embodiment” and the like in various places throughout this specification are not necessarily all referring to one embodiment or a same embodiment. Furthermore, the particular features, structures or characteristics of different embodiments may be combined in any suitable manner to form one or more other embodiments.

It is noted that, unless otherwise explicitly noted or required by context, the word “or” is used in this disclosure in a non-exclusive sense. In addition, unless otherwise explicitly noted or required by context, the word “set” is intended to mean one or more.

Further, the phrase “at least” is used herein at times to emphasize the possibility that other elements can exist besides those explicitly listed. However, unless otherwise explicitly noted (such as by the use of the term “only”) or required by context, non-usage herein of the phrase “at least” does not exclude the possibility that other elements can exist besides those explicitly listed. For example, the phrase, “activation of at least transducer A” includes activation of transducer A by itself, as well as activation of transducer A and activation of one or more other additional elements besides transducer A. In the same manner, the phrase, “activation of transducer A” includes activation of transducer A by itself, as well as activation of transducer A and activation of one or more other additional elements besides transducer A. However, the phrase, “activation of only transducer A” includes only activation of transducer A, and excludes activation of any other transducers besides transducer A.

The word “ablation” as used in this disclosure should be understood to include any disruption to certain properties of tissue. Most commonly, the disruption is to the electrical conductivity and is achieved by heating, which can be generated with resistive or radio-frequency (RF) techniques for example. Other properties, such as mechanical or chemical, and other means of disruption, such as optical, are included when the term “ablation” is used.

The word “fluid” as used in this disclosure should be understood to include any fluid that can be contained within a bodily cavity or can flow into or out of, or both into and out of a bodily cavity via one or more bodily openings positioned in fluid communication with the bodily cavity. In the case of cardiac applications, fluid such as blood will flow into and out of various intra-cardiac cavities (e.g., a left atrium or right atrium).

The words “bodily opening” as used in this disclosure should be understood to include a naturally occurring bodily opening or channel or lumen; a bodily opening or channel or lumen formed by an instrument or tool using techniques that

can include, but are not limited to, mechanical, thermal, electrical, chemical, and exposure or illumination techniques; a bodily opening or channel or lumen formed by trauma to a body; or various combinations of one or more of the above. Various elements having respective openings, lumens or channels and positioned within the bodily opening (e.g., a catheter sheath) may be present in various embodiments. These elements may provide a passageway through a bodily opening for various devices employed in various embodiments.

The words “bodily cavity” as used in this disclosure should be understood to mean a cavity in a body. The bodily cavity may be a cavity provided in a bodily organ (e.g., an intra-cardiac cavity of a heart).

The word “tissue” as used in some embodiments in this disclosure should be understood to include any surface-forming tissue that is used to form a surface of a body or a surface within a bodily cavity, a surface of an anatomical feature or a surface of a feature associated with a bodily opening positioned in fluid communication with the bodily cavity. The tissue can include part or all of a tissue wall or membrane that defines a surface of the bodily cavity. In this regard, the tissue can form an interior surface of the cavity that surrounds a fluid within the cavity. In the case of cardiac applications, tissue can include tissue used to form an interior surface of an intra-cardiac cavity such as a left atrium or right atrium. In some embodiments, the word tissue can refer to a tissue having fluidic properties (e.g., blood).

The term “transducer” as used in this disclosure should be interpreted broadly as any device capable of distinguishing between fluid and tissue, sensing temperature, creating heat, ablating tissue, measuring electrical activity of a tissue surface, stimulating tissue, or any combination thereof. A transducer can convert input energy of one form into output energy of another form. Without limitation, a transducer can include an electrode that functions as, or as part of, a sensing device included in the transducer, an energy delivery device included in the transducer, or both a sensing device and an energy delivery device included in the transducer. A transducer may be constructed from several parts, which may be discrete components or may be integrally formed. In this regard, although transducers, electrodes, or both transducers and electrodes are referenced with respect to various embodiments, it is understood that other transducers or transducer elements may be employed in other embodiments. It is understood that a reference to a particular transducer in various embodiments may also imply a reference to an electrode, as an electrode may be part of the transducer as shown, e.g., with FIG. 4 discussed below.

The term “activation” as used in this disclosure should be interpreted broadly as making active a particular function as related to various transducers disclosed in this disclosure. Particular functions can include, but are not limited to, tissue ablation, sensing electrophysiological activity, sensing temperature and sensing electrical characteristics (e.g., tissue impedance). For example, in some embodiments, activation of a tissue ablation function of a particular transducer is initiated by causing energy sufficient for tissue ablation from an energy source device system to be delivered to the particular transducer. Alternatively, in this example, the activation can be deemed to be initiated when the particular transducer causes a temperature sufficient for the tissue ablation due to the energy provided by the energy source device system. Also in this example, the activation can last for a duration of time concluding when the ablation function is no longer active, such as when energy sufficient for the tissue ablation is no longer provided to the particular transducer. Alternatively, in

this example, the activation period can be deemed to be concluded when the temperature caused by the particular transducer is below the temperature sufficient for the tissue ablation. In some contexts, however, the word “activation” can merely refer to the initiation of the activating of a particular function, as opposed to referring to both the initiation of the activating of the particular function and the subsequent duration in which the particular function is active. In these contexts, the phrase or a phrase similar to “activation initiation” may be used.

The term “program” in this disclosure should be interpreted as a set of instructions or modules that can be executed by one or more components in a system, such a controller system or data processing device system, in order to cause the system to perform one or more operations. The set of instructions or modules can be stored by any kind of memory device, such as those described subsequently with respect to the memory device system 130 shown in FIG. 1. In addition, this disclosure sometimes describes that the instructions or modules of a program are configured to cause the performance of a function. The phrase “configured to” in this context is intended to include at least (a) instructions or modules that are presently in a form executable by one or more data processing devices to cause performance of the function (e.g., in the case where the instructions or modules are in a compiled and unencrypted form ready for execution), and (b) instructions or modules that are presently in a form not executable by the one or more data processing devices, but could be translated into the form executable by the one or more data processing devices to cause performance of the function (e.g., in the case where the instructions or modules are encrypted in a non-executable manner, but through performance of a decryption process, would be translated into a form ready for execution). The word “module” can be defined as a set of instructions.

The word “device” and the phrase “device system” both are intended to include one or more physical devices or sub-devices (e.g., pieces of equipment) that interact to perform one or more functions, regardless of whether such devices or sub-devices are located within a same housing or different housings. In this regard, for example, this disclosure sometimes refers to a “catheter device”, but such catheter device could equivalently be referred to as a “catheter device system”.

In some contexts, the term “adjacent” is used in this disclosure to refer to objects that do not have another substantially similar object between them. For example, object A and object B could be considered adjacent if they contact each other (and, thus, it could be considered that no other object is between them), or if they do not contact each other, but no other object that is substantially similar to object A, object B, or both objects A and B, depending on context, is between them.

Further, the phrase “in response to” commonly is used in this disclosure. For example, this phrase might be used in the following context, where an event A occurs in response to the occurrence of an event B. In this regard, such phrase can include, for example, that at least the occurrence of the event B causes or triggers the event A.

Further still, example methods are described herein with respect to FIGS. 7A, 7B, 8, 9, and 10. Such figures are described to include blocks associated with instructions. It should be noted that the respective instructions associated, e.g., with each of blocks 1206A and 1206B, or any other method blocks herein, need not be separate instructions and may be combined with other instructions to form a combined instruction set. In this regard, the blocks shown in each of the method figures herein are not intended to illustrate an actual

structure of any program or set of instructions, and such method figures, according to some embodiments, merely illustrate the tasks that instructions are configured to perform upon execution by a data processing device system in conjunction with interactions with one or more other devices or device systems.

FIG. 1 schematically illustrates a system 100 for activating transducers, according to some embodiments. The system 100 includes a data processing device system 110, an input-output device system 120, and a processor-accessible memory device system 130. The processor-accessible memory device system 130 and the input-output device system 120 are communicatively connected to the data processing device system 110.

The data processing device system 110 includes one or more data processing devices that implement or execute, in conjunction with other devices, such as those in the system 100, the methods of various embodiments, including the example methods of FIGS. 7A, 7B, 8, 9, and 10 described herein. Each of the phrases “data processing device”, “data processor”, “processor”, and “computer” is intended to include any data processing device, such as a central processing unit (“CPU”), a desktop computer, a laptop computer, a mainframe computer, tablet computer, a personal digital assistant, a cellular phone, and any other device for processing data, managing data, or handling data, whether implemented with electrical, magnetic, optical, biological components, or otherwise.

The memory device system 130 includes one or more processor-accessible memory devices configured to store information, including the information needed to execute the methods of various embodiments, including the example methods of FIGS. 7A, 7B, 8, 9, and 10 described herein. The memory device system 130 may be a distributed processor-accessible memory device system including multiple processor-accessible memory devices communicatively connected to the data processing device system 110 via a plurality of computers and/or devices. On the other hand, the memory device system 130 need not be a distributed processor-accessible memory system and, consequently, may include one or more processor-accessible memory devices located within a single data processing device.

Each of the phrases “processor-accessible memory” and “processor-accessible memory device” is intended to include any processor-accessible data storage device, whether volatile or nonvolatile, electronic, magnetic, optical, or otherwise, including but not limited to, registers, floppy disks, hard disks, Compact Discs, DVDs, flash memories, ROMs, and RAMs. In some embodiments, each of the phrases “processor-accessible memory” and “processor-accessible memory device” is intended to include a non-transitory computer-readable storage medium. And in some embodiments, the memory device system 130 can be considered a non-transitory computer-readable storage medium system.

The phrase “communicatively connected” is intended to include any type of connection, whether wired or wireless, between devices, data processors, or programs in which data may be communicated. Further, the phrase “communicatively connected” is intended to include a connection between devices or programs within a single data processor, a connection between devices or programs located in different data processors, and a connection between devices not located in data processors at all. In this regard, although the memory device system 130 is shown separately from the data processing device system 110 and the input-output device system 120, one skilled in the art will appreciate that the memory device system 130 may be located completely or partially

within the data processing device system **110** or the input-output device system **120**. Further in this regard, although the input-output device system **120** is shown separately from the data processing device system **110** and the memory device system **130**, one skilled in the art will appreciate that such system may be located completely or partially within the data processing system **110** or the memory device system **130**, depending upon the contents of the input-output device system **120**. Further still, the data processing device system **110**, the input-output device system **120**, and the memory device system **130** may be located entirely within the same device or housing or may be separately located, but communicatively connected, among different devices or housings. In the case where the data processing device system **110**, the input-output device system **120**, and the memory device system **130** are located within the same device, the system **100** of FIG. **1** can be implemented by a single application-specific integrated circuit (ASIC) in some embodiments.

The input-output device system **120** may include a mouse, a keyboard, a touch screen, another computer, or any device or combination of devices from which a desired selection, desired information, instructions, or any other data is input to the data processing device system **110**. The input-output device system may include a user-activatable control system that is responsive to a user action. The input-output device system **120** may include any suitable interface for receiving information, instructions or any data from other devices and systems described in various ones of the embodiments. In this regard, the input-output device system **120** may include various ones of other systems described in various embodiments. For example, the input-output device system **120** may include at least a portion a transducer-based device system. The phrase "transducer-based device system" is intended to include one or more physical systems that include various transducers. The phrase "transducer-based device" is intended to include one or more physical devices that include various transducers.

The input-output device system **120** also may include an image generating device system, a display device system, a processor-accessible memory device, or any device or combination of devices to which information, instructions, or any other data is output by the data processing device system **110**. In this regard, if the input-output device system **120** includes a processor-accessible memory device, such memory device may or may not form part or all of the memory device system **130**. The input-output device system **120** may include any suitable interface for outputting information, instructions or data to other devices and systems described in various ones of the embodiments. In this regard, the input-output device system may include various other devices or systems described in various embodiments.

Various embodiments of transducer-based devices are described herein. Some of the described devices are medical devices that are percutaneously or intravascularly deployed. Some of the described devices are moveable between a delivery or unexpanded configuration (e.g., FIG. **3A**, discussed below) in which a portion of the device is sized for passage through a bodily opening leading to a bodily cavity, and an expanded or deployed configuration (e.g., FIG. **3B**, discussed below) in which the portion of the device has a size too large for passage through the bodily opening leading to the bodily cavity. An example of an expanded or deployed configuration is when the portion of the transducer-based device is in its intended-deployed-operational state inside the bodily cavity. Another example of the expanded or deployed configuration is when the portion of the transducer-based device is being changed from the delivery configuration to the intended-de-

ployed-operational state to a point where the portion of the device now has a size too large for passage through the bodily opening leading to the bodily cavity.

In some example embodiments, the device includes transducers that sense characteristics (e.g., convective cooling, permittivity, force) that distinguish between fluid, such as a fluidic tissue (e.g., blood), and tissue forming an interior surface of the bodily cavity. Such sensed characteristics can allow a medical system to map the cavity, for example using positions of openings or ports into and out of the cavity to determine a position or orientation (e.g., pose), or both of the portion of the device in the bodily cavity. In some example embodiments, the described devices are capable of ablating tissue in a desired pattern within the bodily cavity.

In some example embodiments, the devices are capable of sensing characteristics (e.g., electrophysiological activity) indicative of whether an ablation has been successful. In some example embodiments, the devices are capable of providing stimulation (e.g., electrical stimulation) to tissue within the bodily cavity. Electrical stimulation may include pacing.

FIG. **2** is a representation of a transducer-based device **200** useful in investigating or treating a bodily organ, for example a heart **202**, according to one example embodiment.

Transducer-based device **200** can be percutaneously or intravascularly inserted into a portion of the heart **202**, such as an intra-cardiac cavity like left atrium **204**. In this example, the transducer-based device **200** is part of a catheter **206** inserted via the inferior vena cava **208** and penetrating through a bodily opening in transatrial septum **210** from right atrium **212**. In other embodiments, other paths may be taken.

Catheter **206** includes an elongated flexible rod or shaft member appropriately sized to be delivered percutaneously or intravascularly. Various portions of catheter **206** may be steerable. Catheter **206** may include one or more lumens (not shown). The lumen(s) may carry one or more communications or power paths, or both. For example, the lumen(s) may carry one or more electrical conductors **216** (two shown in this embodiment). Electrical conductors **216** provide electrical connections to device **200** that are accessible externally from a patient in which the transducer-based device **200** is inserted.

Transducer-based device **200** includes a frame or structure **218** which assumes an unexpanded configuration for delivery to left atrium **204**. Structure **218** is expanded (e.g., shown in a deployed or expanded configuration in FIG. **2**) upon delivery to left atrium **204** to position a plurality of transducers **220** (three called out in FIG. **2**) proximate the interior surface formed by tissue **222** of left atrium **204**. In this example embodiment, at least some of the transducers **220** are used to sense a physical characteristic of a fluid (e.g., blood) or tissue **222**, or both, that may be used to determine a position or orientation (e.g., pose), or both, of a portion of a device **200** within, or with respect to left atrium **204**. For example, transducers **220** may be used to determine a location of pulmonary vein ostia (not shown) or a mitral valve **226**, or both. In this example embodiment, at least some of the transducers **220** may be used to selectively ablate portions of the tissue **222**. For example, some of the transducers **220** may be used to ablate a pattern around the bodily openings, ports or pulmonary vein ostia, for instance to reduce or eliminate the occurrence of atrial fibrillation.

FIGS. **3A** and **3B** show a transducer-based device system (e.g., a portion thereof shown schematically) that includes a transducer-based device **300** according to one illustrated embodiment. Transducer-based device **300** includes a plurality of elongate members **304** (three called out in each of FIGS. **3A** and **3B**) and a plurality of transducers **306** (three called out

in FIG. 3A and three called out in FIG. 3B as 306a, 306b and 306c). As will become apparent, the plurality of transducers 306 are positionable within a bodily cavity. For example, in some embodiments, the transducers 306 are able to be positioned in a bodily cavity by movement into, within, or into and within the bodily cavity, with or without a change in a configuration of the plurality of transducers 306. In some embodiments, the plurality of transducers 306 are arranged to form a two- or three-dimensional distribution, grid or array of the transducers capable of mapping, ablating or stimulating an inside surface of a bodily cavity or lumen without requiring mechanical scanning. As shown, for example, in FIG. 3A, the plurality of transducers 306 are arranged in a distribution receivable in a bodily cavity (not shown).

The elongate members 304 are arranged in a frame or structure 308 that is selectively movable between an unexpanded or delivery configuration (e.g., as shown in FIG. 3A) and an expanded or deployed configuration (i.e., as shown in FIG. 3B) that may be used to position elongate members 304 against a tissue surface within the bodily cavity or position the elongate members 304 in the vicinity of the tissue surface. In this embodiment, structure 308 has a size in the unexpanded or delivery configuration suitable for delivery through a bodily opening (e.g., via catheter sheath 312) to the bodily cavity. In this embodiment, structure 308 has a size in the expanded or deployed configuration too large for delivery through a bodily opening (e.g., via catheter sheath 312) to the bodily cavity. The elongate members 304 may form part of a flexible circuit structure (e.g., also known as a flexible printed circuit board (PCB) circuit). The elongate members 304 can include a plurality of different material layers. Each of the elongate members 304 can include a plurality of different material layers. The structure 308 can include a shape memory material, for instance Nitinol. The structure 308 can include a metallic material, for instance stainless steel, or non-metallic material, for instance polyimide, or both a metallic and non metallic material by way of non-limiting example. The incorporation of a specific material into structure 308 may be motivated by various factors including the specific requirements of each of the unexpanded or delivery configuration and expanded or deployed configuration, the required position or orientation (e.g., pose), or both of structure 308 in the bodily cavity or the requirements for successful ablation of a desired pattern.

FIG. 4 is a schematic side elevation view of at least a portion of a transducer-based device 400 that includes a flexible circuit structure 401 that is employed to provide a plurality of transducers 406 (two called out) according to an example embodiment. In some embodiments, the flexible circuit structure 401 may form part of a structure (e.g., structure 308) that is selectively movable between a delivery configuration sized for percutaneous delivery and expanded or deployed configurations sized too large for percutaneous delivery. In some embodiments, the flexible circuit structure 401 may be located on, or form at least part of, of a structural component (e.g., elongate member 304) of a transducer-based device system.

The flexible circuit structure 401 can be formed by various techniques including flexible printed circuit techniques. In some embodiments, the flexible circuit structure 401 includes various layers including flexible layers 403a, 403b and 403c (i.e., collectively flexible layers 403). In some embodiments, each of flexible layers 403 includes an electrical insulator material (e.g., polyimide). One or more of the flexible layers 403 can include a different material than another of the flexible layers 403. In some embodiments, the flexible circuit structure 401 includes various electrically conductive layers

404a, 404b and 404c (collectively electrically conductive layers 404) that are interleaved with the flexible layers 403. In some embodiments, each of the electrically conductive layers 404 is patterned to form various electrically conductive elements. For example, electrically conductive layer 404a is patterned to form a respective electrode 415 of each of the transducers 406. Electrodes 415 have respective electrode edges 415-1 that form a periphery of an electrically conductive surface associated with the respective electrode 415.

Electrically conductive layer 404b is patterned, in some embodiments, to form respective temperature sensors 408 for each of the transducers 406 as well as various leads 410a arranged to provide electrical energy to the temperature sensors 408. In some embodiments, each temperature sensor 408 includes a patterned resistive member 409 (two called out) having a predetermined electrical resistance. In some embodiments, each resistive member 409 includes a metal having relatively high electrical conductivity characteristics (e.g., copper). In some embodiments, electrically conductive layer 404c is patterned to provide portions of various leads 410b arranged to provide an electrical communication path to electrodes 415. In some embodiments, leads 410b are arranged to pass through vias (not shown) in flexible layers 403a and 403b to connect with electrodes 415. Although FIG. 4 shows flexible layer 403c as being a bottom-most layer, some embodiments may include one or more additional layers underneath flexible layer 403c, such as one or more structural layers, such as a steel or composite layer. These one or more structural layers, in some embodiments, are part of the flexible circuit structure 401 and can be part of, e.g., elongate member 304. In addition, although FIG. 4 shows only three flexible layers 403a-403c and only three electrically conductive layers 404a-404c, it should be noted that other numbers of flexible layers, other numbers of electrically conductive layers, or both, can be included.

In some embodiments, electrodes 415 are employed to selectively deliver RF energy to various tissue structures within a bodily cavity (not shown) (e.g., an intra-cardiac cavity). The energy delivered to the tissue structures may be sufficient for ablating portions of the tissue structures. The energy delivered to the tissue may be delivered to cause monopolar tissue ablation, bipolar tissue ablation or blended monopolar-bipolar tissue ablation by way of non-limiting example. In some embodiments, each electrode 415 is employed to sense an electrical potential in the tissue proximate the electrode 415. In some embodiments, each electrode 415 is employed in the generation of an intra-cardiac electrogram. In some embodiments, each resistive member 409 is positioned adjacent a respective one of the electrodes 415. In some embodiments, each of the resistive members 409 is positioned in a stacked or layered array with a respective one of the electrodes 415 to form a respective one of the transducers 406. In some embodiments, the resistive members 409 are connected in series to allow electrical current to pass through all of the resistive members 409. In some embodiments, leads 410a are arranged to allow for a sampling of electrical voltage in between each resistive members 409. This arrangement allows for the electrical resistance of each resistive member 409 to be accurately measured. The ability to accurately measure the electrical resistance of each resistive member 409 may be motivated by various reasons including determining temperature values at locations at least proximate the resistive member 409 based at least on changes in the resistance caused by convective cooling effects (e.g., as provided by blood flow).

Referring to FIGS. 3A, 3B, transducer-based device 300 can communicate with, receive power from or be controlled

by a transducer-activation system 322. In some embodiments, elongate members 304 can form a portion of an elongated cable 316 of control leads 317, for example by stacking multiple layers, and terminating at a connector 321 or other interface with transducer-activation system 322. The control leads 317 may correspond to the electrical connectors 216 in FIG. 2 in some embodiments. The transducer-activation device system 322 may include a controller 324 that includes a data processing device system 310 (e.g., from FIG. 1) and a memory device system 330 (e.g., from FIG. 1) that stores data and instructions that are executable by the data processing device system 310 to process information received from transducer-based device 300 or to control operation of transducer-based device 300, for example activating various selected transducers 306 to ablate tissue. Controller 324 may include one or more controllers.

Transducer-activation device system 322 includes an input-output device system 320 (e.g., from FIG. 1) communicatively connected to the data processing device system 310 (e.g., via controller 324 in this embodiment). Input-output device system 320 may include a user-activatable control that is responsive to a user action. Input-output device system 320 may include one or more user interfaces or input/output (I/O) devices, for example one or more display device systems 332, speaker device systems 334, keyboards, mice, joysticks, track pads, touch screens or other transducers to transfer information to, from, or both to and from a user, for example a care provider such as a physician or technician. For example, output from a mapping process may be displayed on a display device system 332. Input-output device system 320 may include a sensing device system 325 configured to detect various characteristics including, but not limited to, at least one of tissue characteristics (e.g., electrical characteristics such as tissue impedance, tissue type, tissue thickness) and thermal characteristics such as temperature. In this regard, the sensing device system 325 may include one, some, or all of the transducers 306 (or 406 of FIG. 4) of the transducer based device 300, including the internal components of such transducers shown in FIG. 4, such as the electrodes 315 and temperature sensors 408.

Transducer-activation device system 322 may also include an energy source device system 340 including one or more energy source devices connected to transducers 306. In this regard, although FIG. 3A shows a communicative connection between the energy source device system 340 and the controller 324 (and its data processing device system 310), the energy source device system 340 may also be connected to the transducers 306 via a communicative connection that is independent of the communicative connection with the controller 324 (and its data processing device system 310). For example, the energy source device system 340 may receive control signals via the communicative connection with the controller 324 (and its data processing device system 310), and, in response to such control signals, deliver energy to, receive energy from, or both deliver energy to and receive energy from one or more of the transducers 306 via a communicative connection with such transducers 306 (e.g., via one or more communication lines through catheter body 314, elongated cable 316 or catheter sheath 312) that does not pass through the controller 324. In this regard, the energy source device system 340 may provide results of its delivering energy to, receiving energy from, or both delivering energy to and receiving energy from one or more of the transducers 306 to the controller 324 (and its data processing device system 310) via the communicative connection between the energy source device system 340 and the controller 324.

In any event, the number of energy source devices in the energy source device system 340 is fewer than the number of transducers in some embodiments. The energy source device system 340 may, for example, be connected to various selected transducers 306 to selectively provide energy in the form of electrical current or power (e.g., RF energy), light or low temperature fluid to the various selected transducers 306 to cause ablation of tissue. The energy source device system 340 may, for example, selectively provide energy in the form of electrical current to various selected transducers 306 and measure a temperature characteristic, an electrical characteristic, or both at a respective location at least proximate each of the various transducers 306. The energy source device system 340 may include as its energy source devices various electrical current sources or electrical power sources. In some embodiments, an indifferent electrode 326 is provided to receive at least a portion of the energy transmitted by at least some of the transducers 306. Consequently, although not shown in FIG. 3A, the indifferent electrode 326 may be communicatively connected to the energy source device system 340 via one or more communication lines in some embodiments. In addition, although shown separately in FIG. 3A, indifferent electrode 326 may be considered part of the energy source device system 340 in some embodiments.

It is understood that input-output device system 320 may include other systems. In some embodiments, input-output device system 320 may optionally include energy source device system 340, transducer-based device 300 or both energy source device system 340 and transducer-based device 300 by way of non-limiting example. Input-output device system 320 may include the memory device system 330 in some embodiments.

Structure 308 can be delivered and retrieved via a catheter member, for example a catheter sheath 312. In some embodiments, a structure provides expansion and contraction capabilities for a portion of the medical device (e.g., an arrangement, distribution or array of transducers 306). The transducers 306 can form part of, be positioned or located on, mounted or otherwise carried on the structure and the structure may be configurable to be appropriately sized to slide within catheter sheath 312 in order to be deployed percutaneously or intravascularly. FIG. 3A shows one embodiment of such a structure. In this example embodiment, each of the elongate members 304 includes a respective distal end 305 (only one called out), a respective proximal end 307 (only one called out) and an intermediate portion 309 (only one called out) positioned between the proximal end 307 and the distal end 305. The respective intermediate portion 309 of each elongate member 304 includes a first or front surface 318a that is positionable to face an interior tissue surface within a bodily cavity (not shown) and a second or back surface 318b opposite across a thickness of the intermediate portion 309 from the front surface 318a. In some embodiments, each of the elongate members 304 is arranged front surface 318a-toward-back surface 318b in a stacked array during an unexpanded or delivery configuration similar to that described in co-assigned International Application No.: PCT/US2012/022061 and co-assigned International Application No.: PCT/US2012/022062, both of which are hereby incorporated herein by reference in their entirety. In many cases a stacked array allows the structure 308 to have a suitable size for percutaneous or intravascular delivery. In this embodiment, the elongate members 304 are arranged to be introduced into a bodily cavity (again not shown) distal end 305 first. For clarity, not all of the elongate members 304 of structure 308 are shown in FIG. 3A. A flexible catheter body 314 is used to deliver structure 308 through catheter sheath 312.

In a manner similar to that described in co-assigned International Application No.: PCT/US2012/022061 and co-assigned International Application No.: PCT/US2012/022062, each of the elongate members **304** is arranged in a fanned arrangement **370** in FIG. 3B. In this embodiment, the fanned arrangement **370** is formed during the expanded or deployed configuration in which structure **308** is manipulated to have a size too large for percutaneous or intravascular delivery. In this example embodiment, structure **308** includes a proximal portion **308a** having a first domed shape **309a** and a distal portion **308b** having a second domed shape **309b**. In this example embodiment, the proximal and the distal portions **308a**, **308b** include respective portions of elongate members **304**. In this example embodiment, the structure **308** is arranged to be delivered distal portion **308b** first into a bodily cavity (again not shown) when the structure is in the unexpanded or delivery configuration as shown in FIG. 3A. In this example embodiment, the proximal and the distal portions **308a**, **308b** are arranged in a clam shell configuration in the expanded or deployed configuration shown in FIG. 3B.

The transducers **306** can be arranged in various distributions or arrangements in various embodiments. In this example embodiment, various ones of the transducers **306** are spaced apart from one another in a spaced apart distribution in the delivery configuration shown in FIG. 3A. In this example embodiment, various ones of the transducers **306** are arranged in a spaced apart distribution in the deployed configuration shown in FIG. 3B. In this example embodiment, various pairs of transducers **306** are spaced apart with respect to one another. In this example embodiment, various regions of space are located between various pairs of the transducers **306**. For example, in FIG. 3B the transducer-based device **300** includes at least a first transducer **306a**, a second transducer **306b** and a third transducer **306c** (all collectively referred to as transducers **306**). In this example embodiment each of the first, the second and the third transducers **306a**, **306b** and **306c** are adjacent transducers in the spaced apart distribution. In this example embodiment, the first and the second transducers **306a**, **306b** are located on different elongate members **304** while the second and the third transducers **306b**, **306c** are located on a same elongate member **304**. In this example embodiment, a first region of space **350** is between the first and the second transducers **306a**, **306b**. In this example embodiment, the first region of space **350** is not associated with any physical portion of structure **308**. In this example embodiment, a second region of space **360** associated with a physical portion of device **300** (e.g., a portion of an elongate member **304**) is between the second and the third transducers **306b**, **306c**. In this example embodiment, each of the first and the second regions of space **350**, **360** does not include a transducer of transducer-based device **300**. In this example embodiment, each of the first and the second regions of space **350**, **360** does not include any transducer. It is noted that other embodiments need not employ a group of elongate members **304** as employed in the illustrated embodiment. For example, other embodiments may employ a structure having a one or more surfaces, at least a portion of the one or more surfaces defining one or more openings in the structure. In these embodiments, a region of space not associated with any physical portion of the structure may extend over at least part of an opening of the one or more openings. In other example embodiments, other structures may be employed to support or carry transducers of a transducer-based device such as a transducer-based catheter. For example, an elongated catheter member may be used to distribute the transducers in a linear

or curvilinear array. Basket catheters or balloon catheters may be used to distribute the transducers in a two-dimensional or three-dimensional array.

FIG. 7A is a block diagram of a method **700** employed according to some example embodiments. In various example embodiments, a memory device system (e.g., memory device systems **130**, **330**) is communicatively connected to a data processing device system (e.g., data processing device systems **110** or **310**) and stores a program executable by the data processing device system to cause the data processing device system to execute method **700** via interaction with at least, for example, a transducer-based device (e.g., transducer-based devices **200**, **300**, or **400**). In these various embodiments, the program may include instructions configured to perform, or cause to be performed, various ones of the instructions associated with method **700**. In some embodiments, method **700** may include a subset of the associated blocks or additional blocks than those shown in FIG. 7A. In some embodiments, method **700** may include a different sequence between various ones of the associated blocks than those shown in FIG. 7A.

Block **702** includes instructions (e.g., graphical representation instructions or graphical interface instructions provided by a program) configured to cause an input-output device system (e.g., input-output device system **120** or **320**) to display a graphical representation of at least a portion of a transducer-based device. For example, FIG. 5A illustrates a graphical interface including a graphical representation **500** provided by the input-output device system according to one example embodiment provided in accordance with block **702**. In this embodiment, the transducer-based device is a catheter-based device similar to devices **200** and **300** shown respectively in FIGS. 2 and 3. In this example embodiment, the graphical interface depicts graphical representation **500** of the transducer-based device as including a first domed portion **500a** associated with a first domed portion of the transducer-based device (e.g., proximal portion **308a** when having the first domed shape **309a**) and a second domed portion **500b** associated with a second domed portion of the transducer-based device (e.g., distal portion **308b** having the second domed shape **309b**). Various other transducer-based devices may be depicted in other embodiments. FIGS. 5A, 5B, 5C, 5D, 5E, 5F, 5G, 5H, 5I and 5J (collectively FIG. 5) are presented in this disclosure in association with various different embodiments. It is understood that each of the different embodiments need not be associated with all of the FIG. 5, and in some cases will only be associated with a subset of the FIG. 5.

In this embodiment, the graphical representation **500** includes a plurality of graphical elements **501**. Each of the graphical elements **501** is respectively associated with a respective one of a plurality of transducer sets. Each respective transducer set includes at least one of a plurality of transducers included as part of the transducer-based device (e.g., transducer-based devices **200**, **300**, or **400**) and each respective transducer set has at least one different transducer than another of the other transducer sets. In this particular embodiment, each respective transducer set has at least one different transducer than each of the others of the other transducer sets.

In this example embodiment, each of at least some of the graphical elements **501** are provided by a respective one of a plurality of transducer graphical elements **502** that include at least a first transducer graphical element **502a**, a second transducer graphical element **502b**, and a third transducer graphical element **502c** (e.g., all the transducer graphical elements collectively referred to as transducer graphical elements **502**).

In this example embodiment, each transducer graphical element **502** is associated with a single respective transducer of the transducer-based device. In some example embodiments, each transducer graphical element **502** is representative of a respective transducer of the transducer-based device. In some example embodiments, each transducer graphical element **502** is representative of a location or position of a respective transducer of the transducer-based device. In this example embodiment, the graphical representation **500** includes a first spatial relationship between the transducer graphical elements **502** that is consistent with a second spatial relationship between the corresponding transducers associated with the transducer graphical elements **502**. An electrocardiogram (ECG/EKG) signal **523** is also shown in the graphical interface of FIG. 5A.

In this example embodiment, each of at least some of the graphical elements **501** are provided by a respective one of a plurality of between graphical elements **504** including a first between graphical element **504a** and a second between graphical element **504b** (e.g., all the between graphical elements collectively referred to as between graphical elements **504**). In various embodiments, each of the between graphical elements **504** is associated with a set of at least two of the transducers of the transducer-based device. In some example embodiments, each of the between graphical elements **504** is associated with a pair of transducers in the transducer-based device. In some example embodiments, each between graphical element **504** is associated with a region of space between a respective pair of transducers in the transducer-based device. In some example embodiments, each between graphical element **504** is associated with a region of space between a respective pair of adjacent ones of the transducers in the transducer-based device.

In this example embodiment, first transducer graphical element **502a** is associated with a first transducer (e.g., first transducer **306a**) of the transducer-based device, second transducer graphical element **502b** associated with a second transducer (e.g., second transducer **306b**) of the transducer-based device, and third transducer graphical element **502c** associated with a third transducer (e.g., third transducer **306c**) of the transducer-based device. In this example embodiment, the first between graphical element **504a** is associated with a first region of space that is between the first and the second transducers and the second between graphical element **504b** is associated with a second region of space that is between the second and the third transducers. In this illustrated embodiment, the first region of space is a region of space that is not associated with any physical part of the transducer-based device (e.g., first region of space **350**) and the second region of space is a region of space that is associated with a physical part of the transducer-based device (e.g., second region of space **360**). In this example embodiment, each of the first and the second between graphical elements **504a**, **504b** is associated with a region of space that does not include a transducer of the transducer-based device. In this example embodiment, each of the first and the second between graphical elements **504a**, **504b** is associated with a region of space that does not include any transducer. It is understood that a “region of space” need not be a vacant space but can include physical matter therein.

In this example embodiment, the second transducer graphical element **502b** is depicted in a first direction (e.g., represented by arrow **506a**) from the first transducer graphical element **502a**, and the first between graphical element **504a** is positioned between the second and the first transducer graphical elements **502b**, **502a** in the graphical representation. In this example embodiment, the third transducer graphical ele-

ment **502c** is depicted in a second direction (e.g., represented by arrow **506b**) from the second transducer graphical element **502b**, and the second between graphical element **504b** is positioned between the second and the third transducer graphical elements **502b**, **502c**. In this example embodiment, the first and the second directions are non-parallel to each other. In this example embodiment, the first between graphical element **504a** is formed, at least in part, at a location in the graphical representation intersected by the first direction from the first transducer graphical element **502a** and the second between graphical element **504b** is formed, at least in part at a location in the graphical representation intersected by the second direction from the second transducer graphical element **502b**. In other example embodiments, other spatial relationships exist between the transducer graphical elements **502** and the between graphical elements **504** in the graphical representation. It is understood that arrows **506a**, **506b** do not form part of the graphical representation in this embodiment.

In this example embodiment, each of the between graphical elements **504** includes a first end **507** (only one called out), a second end **508** (only one called out) and an elongate portion **509** (only one called out) extending between the first and the second ends **507**, **508**. The transducer graphical elements **502**, the between graphical elements **504**, or both may have different sizes, shapes or forms than those shown in the illustrated embodiment. In some embodiments, different ones of the transducer graphical elements **502** may be depicted with different shapes, sizes or forms in the graphical representation. In some embodiments, different ones of the between graphical elements **504** may be depicted with different shapes, sizes or forms in the graphical representation. In this embodiment, the respective elongate portion **509** of the first between graphical element **504a** is depicted extending along the first direction (e.g., again represented by arrow **506a**) and the respective elongate portion **509** of the second between graphical element **504b** is depicted extending along the second direction (e.g., again represented by arrow **506b**). In this example embodiment the first direction is depicted generally orthogonal to the second direction in the three-dimensional graphical representation. Other orientations between the first and the second direction are possible in other embodiments. For example, FIG. 6 illustrates a graphical interface including a graphical representation **600** provided by an input-output device system (e.g., input-output device system **120** or **320**) according to another example embodiment. In a manner similar to FIG. 5A, the graphical interface of FIG. 6 provides a graphical representation **600** that includes a plurality of graphical elements **601**, each of the graphical elements **601** associated with a respective one of a plurality of transducer sets. Each respective transducer set includes at least one of a plurality of the transducers included as part of the transducer-based device and each respective transducer set has at least one different transducer than another of the other transducer sets. In this particular embodiment, each respective transducer set has at least one different transducer than each of the others of the other transducer sets.

In a manner similar to the embodiment of FIG. 5A, the plurality of graphical elements **601** include a plurality of transducer graphical elements **602** (e.g., including transducer graphical elements **602a**, **602b** and **602c**) and a plurality of between graphical elements **604**. In a manner similar to the embodiment of FIG. 5A, each of the transducer graphical elements **602** is associated with a transducer of a transducer-based device and each of the between graphical elements **604** is associated with a region of space between a pair of transducers of a transducer based-device. In a manner similar to the embodiment of FIG. 5A, each of at least some of the

between graphical elements (e.g., first between graphical element 604a and a third between graphical element 604c) is associated with a respective region of space that is not associated with any physical part of the transducer-based device. In a manner similar to the embodiment shown in FIG. 5A, each of at least some of the between graphical elements (e.g., second between graphical elements 604b) is associated with a respective region of space that is associated with a physical portion of the transducer-based device (e.g., an elongate member 304). In a manner similar to the embodiment shown in FIG. 5A, each of the between graphical elements 604 includes a first end 607 (only one called out), a second end 608 (only one called out) and an elongate portion 609 (only one called out) extending between the first and the second ends 607, 608. In this example embodiment, the respective elongate portion 609 of each of two of first ones of the between graphical element (e.g., between graphical elements 604a, 604b) is depicted extending along a respective first direction (e.g., represented by respective ones of arrows 606a, 606b), and the respective elongate portion 609 of a second one of the between graphical elements 604 (e.g., between graphical element 604c) is depicted extending along a second direction (e.g., represented by arrow 606c). In this example embodiment, the second direction is oblique to each of the first directions. In this example embodiment, the second direction forms an acute angle with respect to each of the first directions. In this illustrated embodiment, each between graphical element 604 is associated with a region of space that does not include a transducer of a transducer-based device. In this illustrated embodiment, each between graphical element 604 is associated with a region of space that does not include any transducer.

Referring back to FIG. 5A, at least a portion of the transducer graphical elements 502, and at least a portion of the between graphical elements 504 are arranged in a plurality of rows 510 (two called out) and a plurality of columns 512 (two called out, each column 512 identified in the graphical representation by a respective one of letters "A", "B", "C", "D", "E", "F", "G", "H", "I", "J", "K", "L", "M", "N", "O", "P", "Q", "R", "S", and "T"). In this example embodiment, a portion of each of the columns 512 corresponds to region of space associated with a physical portion of the transducer-based device (e.g., an elongate member 304). In this example embodiment, each of the columns 512 corresponds to at least a portion of the transducers located on a particular elongate member of a transducer-based device (e.g., an elongate member 304). In this example embodiment, each of the columns 512 corresponds to at least a portion of the transducers located on a respective one of a pair of domed portions arranged in a clam shell configuration similar to the embodiments of FIG. 3B. In embodiments in which each domed portion is formed by a respective portion of each of a plurality of elongate members (e.g., elongate members 304), a set of two or more of the columns 512 may correspond to the transducers located on a single one of the elongate members.

In this example embodiment, a portion of each of the rows 510 corresponds to regions of space not associated with any physical portion of the transducer-based device (e.g., regions of space 350 between adjacent ones of the elongate members 304). In other example embodiments, different numbers of transducer graphical elements 502 and different numbers and spatial arrangements of between graphical elements 504 may be depicted in the graphical representation. In other example embodiments, different numbers and spatial arrangements of rows 510 and columns 512 may be depicted in the graphical representation. In various embodiments, each of the between graphical elements (e.g., between graphical elements 504,

604) depicted in the graphical representation are representative of a respective physical path extending between a respective pair of transducers of the transducer-based device. Each of the physical paths may extend over a physical surface of the transducer-based device or over a portion of an opening defined by a physical surface of the transducer-based device. In the embodiment shown in FIG. 6, each between graphical element 604 is representative of a respective physical path extending between the respective transducers associated with the adjacent pair of transducer graphical elements 602 that the between graphical element 604 extends between. In the embodiment shown in FIG. 6, each adjacent pair of the transducer graphical elements 602 may be provided along a row 610 (two called out) of the graphical elements 601, along a column 612 (two called out) of the graphical elements 601, or diagonally between a row 610 and a column 612.

Referring back to FIG. 5A, the transducer graphical elements 502 and the between graphical elements 504 in each respective one of the rows 510 are interleaved with respect to one another along the respective one of the rows 510. In this illustrated embodiment, the transducer graphical elements 502 and the between graphical elements 504 in each respective one of the columns 512 are interleaved with respect to one another along the respective one of the columns 512. In this illustrated embodiment, each one of the plurality of columns 512 shares a same transducer graphical element 502 with one of the plurality of rows 510. In this illustrated embodiment, each respective one of the plurality of columns 512 excludes any of the between graphical elements 504 included in each of the plurality of rows 510. In this illustrated embodiment, at least a first one of the between graphical elements 504 (e.g., second between graphical element 504b) is depicted in the graphical representation between two adjacent ones of the plurality of rows 510 and at least a second one of the plurality of between graphical elements 504 (e.g., first between graphical element 504a) is positioned between two adjacent ones of the plurality of columns 512. In this example embodiment, the plurality of rows 510 and the plurality of columns 512 are depicted as a three-dimensional arrangement in the graphical representation. In this example embodiment, at least two of the plurality of columns 512 are depicted in the graphical representation extending along respective directions that converge with respect to one another. In this illustrated embodiment, at least two of the plurality of columns 512 are depicted in the graphical representation extending along non-parallel directions and at least two of the plurality of rows 510 are depicted extending along parallel directions. In this illustrated embodiment, the rows 510 and the columns 512 are depicted in the graphical representation in an arrangement in which the columns 512 are circumferentially arranged. In this illustrated embodiment, the rows 510 and the columns 512 are depicted in the graphical representation in an arrangement having a generally spherical shape. In this illustrated embodiment, the respective first end 507 and the respective second end 508 of each of at least some of the plurality of between graphical elements 504 connects to a transducer graphical element 502 in the graphical representation. The transducer graphical elements 602 and a portion of the between graphical elements 604 in the embodiment of FIG. 6 are arranged in a similar manner to the embodiment shown in FIG. 5A. In the embodiment of FIG. 6, at least some of the between graphical elements 604 extend along respective directions that form acute angles with the respective directions extended along by others of the between graphical elements 604. In the embodiment of FIG. 6, at least some of the between graphical ele-

ments **604** extend along respective directions that form acute angles with the respective directions extended along by a row **610** or a column **612**.

The graphical interface of FIG. **5B** includes the graphical representation **500** with the addition of identification labels **513** (two called out) to each of the transducer graphical elements **502**. In this example embodiment identification labels are applied by operating the input-output device system to activate a control button **514** identified as “View Options”. Selection, activation, or both selection and activation of a control button, a selection box or other graphical element provided in the various embodiments may be accomplished via various input-output device system controls that can include a touch screen, keyboard or computer mouse by way of non-limiting example. In this embodiment, selection of control button **514** causes the selection menu **515** identified as “Model View Options” to appear in the graphical representation. Selection menu **515** provides various selection boxes **516** that are selectable to vary the graphical representation of the portion of the transducer-based device between a three-dimensional representation (e.g., as depicted in FIGS. **5A** and **5B**) and a two dimensional representation (e.g., as depicted in FIG. **5D**). Various two-dimensional representations are possible in various embodiments. For example, the two-dimensional representation depicted in FIG. **5D** is shown in a “Mercator-type” representation in which the first domed portion **500a** (e.g., shown in FIG. **5A**) of the depicted transducer-based device is depicted as first Mercator projection **518a** and the second domed portion **500b** (e.g., shown in FIG. **5A**) of the depicted transducer-based device is depicted as a second Mercator projection **518b**. The first and the second Mercator projections **518a** and **518b** advantageously allow for simultaneous viewing of all the transducer graphical elements **502** and the between graphical elements **504**. Other two-dimensional representations including polar projections are also selectable.

Selection menu **515** provides various selection boxes **520** that can control mouse drag functions between rotating and panning modes. A rotating mode may be advantageously used for manipulation of a three-dimensional representation of the transducer-based device to allow for viewing a portion of the three-dimensional representation that was not previously viewable. Selection menu **515** includes a plurality of selection boxes **522** that allow for variations in the viewable content of the graphical representation. In this embodiment, a selection box **522** allows for the selective inclusion in the graphical representation of graphical elements associated with various anatomical features. In some example embodiments, the graphical elements associated with the anatomical features are selectable from a menu and may be tailored to a particular procedure in which the transducer-based device is employed. Various ones of the selection boxes **522** allow for selective inclusions of the transducer graphical elements **502** (e.g., indicated as “Electrodes” in this illustrated embodiment) and the selective inclusion of the between graphical elements **504** (e.g., indicated as “Segments” in this illustrated embodiment). In this embodiment, a selection box **522** allows for the selective inclusion in the graphical representation of graphical elements associated with lesions which may be of particular interest in embodiments in which various transducers of the transducer based-device ablate tissue to form the lesions therein.

In this example embodiment, a selection box **522** allows for the selective inclusion of identification labels **513** (e.g., indicated as “Labels” in this illustrated embodiment). In this example embodiment, each of the identification labels **513** is employs an alpha-numeric format including a letter represen-

tative of the column **512** in which a corresponding transducer graphical element is located and a number representative of a location of the transducer graphical element **502** in the corresponding column **514**. Other identification schemes may be employed in other embodiments.

Having described examples of the graphical representation displayed according to the instructions of block **702** in FIG. **7A**, the selection of one or more graphical elements in the graphical representation according to some embodiments will now be described with respect to block **710** in FIG. **7A**. Accordingly, although FIG. **7A** shows block **710** located after blocks **707** and **708**, the invention is not limited to this arrangement, and the selection of one or more graphical elements according to block **710** can occur at any time the graphical elements are selectable, such as when they are displayed in the graphical representation displayed according to block **702**. Blocks **704**, **706**, **707**, and **708** in FIG. **7A** are described afterwards.

In this regard, the selection according to the instructions of block **710** includes, in some embodiments, multiple constituent or sub-selections (although in other embodiments, the selection according to the instructions of block **710** includes only a single selection). For instance, in some embodiments, block **710** includes selection instructions configured to cause, due to execution of the selection instructions by the data processing device system (e.g., exemplified by data processing device systems **110** or **310**), selection of a graphical element. In some embodiments, such selection instructions include a first group of instructions configured to cause the data processing device system to receive or process, via the input-output device system, a user instruction to select a graphical element. In some of these embodiments, such selection instructions also include a second group of instructions configured to cause the data processing device system to perform its own selection of the graphical element in response to receiving the user instruction. For instance, the user instruction to select the graphical element might originate from a user clicking a mouse button (e.g., a first constituent selection) while a cursor is above a user-selected graphical element. In this case, the first group of instructions could configure the data processing device system to recognize this user instruction when it is received via the data input-output device system as a user instruction to select the user-selected graphical element below the cursor at the time of the mouse-button click. In some embodiments, the second group of instructions may configure the data processing device system, in response to the first group of instructions recognizing this user instruction, to perform its own selection (e.g., a second constituent selection) of the user-selected graphical element at least by causing, via the input output device system, the display of the user-selected graphical element to change one or more visual characteristics of the user-selected graphical element. Accordingly, the selection according to the instructions of block **710** may be deemed, in some embodiments, to involve a first, user-based constituent selection and a second, machine-based or automatic constituent selection triggered by the user-based constituent selection.

Although a mouse-click was provided above as an example of a user-based constituent selection, and the changing of a visual characteristic of the user-selected graphical element was provided as an example of a machine-based constituent selection, it should be noted, however, that any form of user-based selection or machine-based selection of a graphical element known in the art can be used. In this regard, direct interaction with a graphical element itself (e.g., by way of a mouse click on the graphical element) is not required to directly select the graphical element or its corresponding

transducer. For example, a user might type a unique identifier associated with a graphical element or transducer via a keyboard, which can cause direct selection of that graphical element or transducer.

Further, although a user-based constituent selection of a user-selected graphical element followed by a machine-based constituent selection of that user-selected graphical element was provided above as an example of constituent selections involved with block 710, it should be noted that a user-based constituent selection of a first user-selected graphical element can also cause a machine-based constituent selection of a second, different, non-user-selected graphical element. For example, a user-performed mouse-click while the mouse cursor is above a user-selected between-graphical element 504 (e.g., a user-based constituent selection) can cause, possibly among other things, a machine-based constituent selection of the non-user-selected transducer graphical elements 502 at each end of the user-selected between graphical element 504. In this regard, the phrase, "user-selected", when used herein to describe a selected graphical element (e.g., a transducer graphical element or a between graphical element), is intended to refer to a graphical element directly selected by a user, as opposed to a non-user-selected graphical element, which is a machine-selected graphical element that is machine-selected either in response to no user instruction to select any graphical element or in response to a user-instruction to select a user-selected graphical element different than the machine-selected graphical element. In cases where a user selection of a user-selected graphical element causes a machine-selection of a different graphical element, it can be said that the different graphical element is indirectly selected by the user.

Further still, although a user-based constituent selection followed by a machine-based constituent selection was provided above as an example of constituent selections involved with block 710, it should be noted that any number of constituent selections, whether user-based or machine-based, can be involved with block 710. For example, depending upon how the user-interface is structured, one or more user-based constituent selections may result in one or more machine-based constituent selections. For instance, multiple user gestures (e.g., a double-fingered gesture on a touch screen, a mouse click-drag-and-release sequence, or other multiple user-gesture technique) might be required to identify a particular user-selected graphical element in order to cause the data processing device system to change the visual characteristics of (or provide another form of selection of) the particular user-selected graphical element. For another example, multiple user-based constituent selections might be a mouse click-and-hold followed by a dragging of a cursor to expand a selection box originating from the initial mouse click location, followed by a releasing of the mouse button to define the final size of the selection box. This initial user-based selection (comprised of the multiple user-based constituent selections) could be recognized by the data processing device system according to the above-discussed first group of instructions, and cause multiple machine-based or automatic constituent selections performed by the data processing device system according to the above-discussed second group of instructions. For instance, these multiple machine-based or automatic constituent selections could include a first constituent selection by the data processing device system of all graphical elements residing within the selection box, followed by a second constituent selection of only those graphical elements deemed to reside within the selection box whose corresponding transducers have been deemed acceptable for concurrent selection (see, e.g., the discussions below regarding block

707 in FIG. 7A, as well as the discussions below regarding FIG. 7B) or activation (see, e.g., the discussions below regarding block 708 in FIG. 7A and block 804 in FIG. 8).

Further still, although one or more user-based constituent selections followed by one or more machine-based constituent selections was provided above as an example of constituent selections involved with block 710, it should be noted that block 710 might not involve any user-based constituent selections. For example, graphical element selection according to block 710 might occur based upon data received from transducers, and this data might result in one or more machine-based or automatic constituent selections performed by the data processing device system.

It should be noted that, whenever a selection of a graphical element is discussed herein, such selection, in some embodiments, can include the above-discussed constituent selections. However, the above-discussed constituent selections are not limited to just selections of graphical elements and can apply to any selection described herein. For example, one or more user-based constituent selections of a user-selected graphical element can lead to one or more machine-based constituent selections of the user-selected graphical element or some other graphical element(s), which can lead to one or more machine-based selections of one or more transducers corresponding to the machine-selected graphical elements, the machine-based selection(s) of the one or more transducers possibly causing an activation of the one or more transducers. For another example, one or more user-based constituent selections of a user-selected graphical element can lead to one or more machine-based constituent selections of one or more data objects associated with the user-selected graphical element, one or more other associated graphical elements, one or more transducers associated with the user-selected graphical element, or one or more other objects associated with the user-selected graphical element, such as for purposes of viewing or changing properties of the one or more data objects or causing an activation based upon information provided by the one or more data objects. It should also be noted that the above-discussion regarding block 710 and user and machine based selections and constituent selections may apply, in some embodiments, to block 710 in FIG. 7B, block 808 in FIG. 8, block 908 in FIG. 9, blocks 807 and 808 in FIG. 10, or any other selection-based discussions herein.

In view of the above-discussion regarding selection types involved with block 710, in some embodiments, the instructions of block 710 are provided in a program that includes instructions configured to cause the data processing device system to receive a selection from the input-output device system of a transducer graphical element (e.g., transducer graphical element 502 or 602).

The selection of one or more graphical elements according to instructions of block 710 in FIG. 7A may cause, in some embodiments, an activation of at least some transducer sets of a transducer-based device (e.g., 200, 300, or 400) according to instructions of block 712. In some embodiments, block 712 includes instructions configured to cause an activation of each of at least some of the transducer sets of the transducer-based device (e.g., again exemplified by transducer based devices 200, 300, or 400) in response to receiving a selection of a corresponding one of the graphical elements (e.g., graphical elements 501, 601) in accordance with selection instructions included in block 710.

In some embodiments, the program can include activation instructions (e.g., in accordance with block 712) configured to, in response to receiving the selection of a transducer graphical element (e.g., transducer graphical element 502, 602), cause, via the input-output device system, activation of

the respective transducer of the transducer-based device corresponding to the selected transducer graphical element. In various embodiments, the instructions configured to activate the respective transducer corresponding to the selected transducer graphical element include instructions that are configured to cause energy from an energy source device system (e.g., energy source device system **340**) to be delivered to the respective transducer. In some embodiments, a sensing device system (e.g., provided at least in part by a number of the transducers) is arranged to sense at least one tissue electrical characteristic (e.g., tissue impedance) at a respective location at least proximate the respective transducer corresponding to the selected transducer graphical element with the energy delivered to the transducer (e.g., in some embodiments, tissue impedance may be measured between transducers on the structure **308** or between a transducer on the structure **308** and the indifferent electrode **326**). In some of these various embodiments, the energy is sufficient for ablating tissue (e.g., tissue-ablating energy). In some of these various embodiments, an indifferent electrode (e.g., indifferent electrode **326**) is provided (e.g., usually to an external surface of a body) while the transducer-based device is received in a bodily cavity within the body. A portion of the tissue-ablating energy delivered to the respective transducer corresponding to the selected transducer graphical element may be transmitted from the respective transducer to the indifferent electrode in a process typically referred to as monopolar ablation. In some embodiments, the instructions of block **712** that are configured to activate the respective transducer corresponding to the selected transducer graphical element includes instructions that are configured to cause a sensing device system (e.g., sensing device system **325**) to detect electrophysiological activity in an intra-cardiac cavity at a location at least proximate the respective transducer. The detected electrophysiological activity can be displayed as an electrogram via the input-output device system (e.g. electrograms **535** in various ones of FIG. **5**). In some embodiments, detection of electrophysiological activity in an intra-cardiac cavity at a location at least proximate various ones of the transducers occurs continuously. Other forms of activation of the respective transducer corresponding to the selected transducer graphical element are possible in other embodiments. In some embodiments, activation of the respective transducer corresponding to the selected transducer graphical element under the influence of the instructions configured to activate the respective transducer is referred to as monopolar activation. Monopolar activation can include activation for monopolar ablation or monopolar electrogram generation by way of non-limiting example.

For another example, in some embodiments, the instructions of block **710** are provided in a program that includes selection instructions configured to cause, due to execution of the selection instructions by the data processing device system (e.g., again exemplified by data processing device systems **110** or **310**), reception of a selection from the input-output device system of a between graphical element (e.g., between graphical elements **504** or **604**). In accordance with the instructions of block **712** the program can include activation instructions configured to, in response to receiving the selection, cause activation, via the input-output device system, of a respective set of two or more of the transducers (e.g., a pair of the transducers in some embodiments) of the transducer-based device corresponding to the between graphical element.

Advantageously, activating a set of two or more of the transducers based on a selection of a single graphical element (e.g., between graphical element **504** or **604**) provides for a

workflow that is less cumbersome and more expeditious than individually selecting the respective graphical elements (e.g., transducer graphical elements **502** or **602**) associated with each transducer of the set of two or more of the transducers, especially when 50, 100, 200 or even over 300 or more transducer graphical elements are provided in the graphical representation. This is even more advantageous, when a single graphical element (e.g., between graphical element **504** or **604**) provides additional information (e.g., spatial information) relating each of the transducers in the set of two or more of the transducers. For example, a between graphical element **504** or **604** can indicate a distance between or acceptability-of-activation of transducers of a corresponding transducer pair, and, accordingly, the between graphical element **504** or **604** provides, in some embodiments, information about the corresponding pair of transducers and, thereby, makes the selection process more efficient. In addition, allowing selection of the between-graphical elements for corresponding transducer activation can provide a more intuitive user-interface in certain applications. For example, such an arrangement allows a user to make selections along an ablation path or a path along which data is to be obtained, without having to focus on the transducers required to make that ablation path or acquire that data. The user can, for example, just select a path using between graphical elements (e.g., user-based selection(s)/constituent selection(s)), and the corresponding transducers are automatically selected (e.g., machine-based selection(s)/constituent selection(s)) in response. Since various ones of the between graphical elements need not be tied to any physical portion of the transducer-based device, they can be freely designed to reflect the path (e.g., over tissue or fluid) in which their corresponding transducers will interact when activated (e.g., by causing ablation or gathering data). In this regard, if the between graphical elements are configured to accurately represent their respective path segments in which ablation or data gathering will occur, according to some embodiments, the user can gain an even better understanding of the expected results of activation of the corresponding transducers.

In some of the embodiments where the instructions according to block **712** are configured to cause a data processing device system to activate a respective set of two or more of the transducers, the instructions according to block **712** include instructions that are configured to cause energy from an energy source device system (e.g., energy source device system **340**) to be delivered to the respective set of two or more of the transducers. In some embodiments, a sensing device system (e.g., sensing device system **325**) is arranged to sense at least one tissue electrical characteristic (e.g., tissue impedance) at respective locations at least proximate each transducer of the respective set of two or more of the transducers with the energy delivered to the respective set of two or more of the transducers (e.g., in some embodiments, tissue impedance may be measured between transducers on the structure **308** or between a transducer on the structure **308** and the indifferent electrode **326**). In some embodiments, (a) a portion of the energy delivered to a first transducer of the respective set of two or more of the transducers (e.g., first transducer **304a**) is transmitted by the first transducer, (b) a portion of the energy delivered to a second transducer of the respective set of two or more of the transducers (e.g., second transducer **304b**) is transmitted by the second transducer, or both (a) or (b). In some of embodiments, (a) a portion of the energy delivered to a first transducer of the respective set of two or more of the transducers (e.g., first transducer **304a**) is transmitted by the first transducer to a second transducer of the respective set of two or more of the transducers (e.g., second

transducer 304b), (b) a portion of the energy delivered to the second transducer of the respective set of two or more of the transducers is transmitted by the second transducer to the first transducer, or both (a) or (b). In some embodiments, the energy is sufficient for ablating tissue (e.g., tissue ablating energy). In some example embodiments, a selected between graphical element (e.g., between graphical elements 504 or 604) is representative of a physical path extending between a respective pair of the transducers associated with the selected between graphical element and the energy is sufficient for ablating a portion of tissue extending along the physical path. A portion of the tissue-ablating energy may be transmitted between the respective pair of the transducers in a process typically referred to as bipolar ablation. In some embodiments, an indifferent electrode (e.g., indifferent electrode 326) is provided (e.g., usually to an external surface of a body) while the transducer-based device is received in a bodily cavity within the body. Some of the tissue-ablating energy may be transmitted between the respective pair of the transducers while some of the tissue-ablating energy may be transmitted from various ones of the respective pair of the transducers to the indifferent electrode in a process typically referred to as blended monopolar-bipolar ablation. The term “bipolar ablation” as used in this disclosure is to be interpreted broadly to include blended monopolar-bipolar ablation in some embodiments.

In addition to embodiments where the instructions according to block 712 are configured to cause a data processing device system to cause bipolar ablation, the instructions according to block 712, in some embodiments, are configured to cause a data processing device system to cause multi-transducer monopolar ablation with the respective set of two or more of the transducers, e.g., dual monopolar ablation for two transducers, or triple monopolar ablation for three transducers. In such cases, for example, the respective set of two or more of the transducers may be ‘queued’ for monopolar ablation, such that monopolar ablation occurs for each transducer in the respective set of two or more of the transducers within some period of time, but not necessarily at the same time or even contiguously one right after another. In this regard, references herein to the occurrence of monopolar ablation for more than one transducer may include this multi-transducer monopolar ablation according to some embodiments. In addition, any reference herein to the occurrence of bipolar ablation may be replaced with the occurrence of dual monopolar ablation (or other multi-transducer monopolar ablation when more than two transducers are involved), according to some embodiments.

In some embodiments, the instructions, according to block 712, configured to activate the respective set of two or more of the transducers include instructions that are configured to cause a sensing device system to detect electrophysiological activity in an intra-cardiac cavity at each of respective locations at least proximate each of the transducers of the set. The detected electrophysiological activity detected at each of the respective locations can be displayed as an electrogram via the input-output device system (e.g., electrograms 535 shown in various ones of FIG. 5). In some example embodiments, a combined electrogram (e.g., a bipolar electrogram) (not shown) may be determined (e.g., by instructions provided by a program) from the respective electrograms associated with each transducer of the respective set of two or more of the transducers. The program may include instructions configured to display the combined electrogram via the input-output device system. Other forms of activation are possible in other embodiments involving activation of a respective set of two or more of the transducers. In some embodiments, activation

under the influence of the instructions configured to activate a respective pair of transducers associated with a selected between graphical element may be referred to as bipolar activation when the pair of the transducers is activated in a bipolar manner (e.g., bipolar ablation or bipolar electrogram generation). Selection of each of at least some of the plurality of graphical elements 501 or 601 in accordance with the instructions of block 710 may include independent selections of each of the at least some of the graphical elements 501 or 601.

Having discussed embodiments where blocks 710 and 712 follow block 702 in FIG. 7A, a discussion will now begin regarding embodiments where block 704 follows block 702. Block 704 of method 700, in some embodiments, includes instructions (e.g., input instructions included in a program) that cause the data processing device system (e.g., data processing device systems 110 or 310) to receive transducer data from at least some of the transducers via the input-output device system. This transducer data can take various forms, such as one or more of various detected characteristics including, but not limited to, e.g., electrical characteristics (such as electrical potential or impedance), thermal characteristics (such as temperature), and force.

Various embodiments can process or analyze the transducer data received by the data processing device system according to the instructions of block 704 in order to, for example, generate and possibly display one or more electrograms, determine the acceptability of selection or activation of particular transducers, generate a map (e.g., a map of anatomical features), determine the status of tissue ablation, or combinations of these tasks. Accordingly, it should be noted that some embodiments need not be limited to any particular form of processing or analysis of the transducer data received by the data processing device system according to the instructions of block 704. In this regard, although various embodiments need not be limited to any particular processing or analysis of the transducer data received according to the instructions of block 704, block 706 of method 700 pertains to some embodiments where the transducer data is analyzed to identify various regions that correspond to at least a portion of one or more anatomical features. For example, according to some embodiments, block 706 includes instructions (e.g., determination or identification instructions included in a program) that are configured to identify various regions 525 (e.g., FIGS. 5C-5I) in the graphical representation (generated according to the instructions of block 702) that correspond to at least a portion of one or more anatomical features based at least on an analysis of the transducer data.

In embodiments such as these, where the transducer-based device is deployed in a bodily cavity (e.g., when the transducer-based device takes the form of a catheter device arranged to be percutaneously or intravascularly delivered to a bodily cavity), it may be desirable to perform various mapping procedures in the bodily cavity. Although these mapping procedures can be implemented according to the instructions of block 706, these mapping procedures can be performed at other times, such as any time during the generation of or after the display of the graphical representation of at least a portion of the transducer-based device (e.g., block 702, 802, or 902). It is noted that in some embodiments, the mapping procedure need not be limited to the mapping of various anatomical landmarks. For example, when the bodily cavity is an intra-cardiac cavity, the mapping procedure may include mapping electrophysiological activity in the intra-cardiac cavity. In some embodiments, the mapping procedure may include mapping varying degrees of contact between various ones of

the transducers (e.g., electrodes) and a tissue surface of a bodily cavity into which the transducers are located.

An example of the mapping performed by devices according to various embodiments (such as those represented by block **706** in FIG. **7A**) would be to locate the position of the ports of various bodily openings positioned in fluid communication with a bodily cavity. For example, in some embodiments, it may be desired to determine the locations of various ones of the pulmonary veins or the mitral valve that each interrupt an interior surface of an intra-cardiac cavity such as a left atrium.

In some example embodiments, the mapping is based at least on locating such bodily openings by differentiating between fluid and tissue (e.g., tissue defining a surface of a bodily cavity). There are many ways to differentiate tissue from a fluid such as blood or to differentiate tissue from a bodily opening in case a fluid is not present. Four approaches may include by way of non-limiting example:

1. The use of convective cooling of heated transducer elements by fluid. A slightly heated arrangement of transducers that is positioned adjacent to the tissue that forms the interior surface(s) of a bodily cavity and across the ports of the bodily cavity will be cooler at the areas which are spanning the ports carrying the flow of fluid.

2. The use of tissue impedance measurements. A set of transducers positioned adjacently to tissue that forms the interior surface(s) of a bodily cavity and across the ports of the bodily cavity can be responsive to electrical tissue impedance. Typically, heart tissue will have higher associated tissue impedance values than the impedance values associated with blood.

3. The use of the differing change in dielectric constant as a function of frequency between blood and tissue. A set of transducers positioned around the tissue that forms the interior surface(s) of the atrium and across the ports of the atrium monitors the ratio of the dielectric constant from 1 KHz to 100 KHz. Such can be used to determine which of those transducers are not proximate to tissue, which is indicative of the locations of the ports.

4. The use of transducers that sense force (e.g., force sensors). A set of force detection transducers positioned around the tissue that forms the interior surface of the bodily cavity and across the bodily openings or ports of the bodily cavity can be used to determine which of the transducers are not engaged with the tissue, which is indicative of the locations of the ports.

The graphical interface of FIG. **5C** includes various regions **525c** (e.g., part of a plurality of regions collectively referred to as regions **525** when considering all of the FIG. **5**) added to the graphical representation **500** of the transducer-based device. The regions **525** could be identified and displayed according to the instructions of block **706** in FIG. **7A** in some embodiments. Although, such regions **525** could be identified and displayed at other times or according to other instructions. In some embodiments, the graphical interface depicted in FIG. **5C** is generated after the transducer-based device was received in a bodily cavity having various anatomical features of interest and the control button **526** identified as "Map" was activated via the input-output device system to select a mode referred to as "Flow". Techniques for flow-based mapping techniques are disclosed in commonly assigned U.S. Patent Application Publication No.: US 2008/0004534. In various embodiments associated with various ones of FIG. **5**, the anatomical features of interest are ports of a mitral valve and various pulmonary veins positioned in fluid communication with an intra-cardiac cavity (e.g., a left atrium in this embodiment). In these various embodiments, the transducers of the

transducer-based device are distributed adjacent respective regions in the intra-cardiac cavity that can include relatively lower blood flow regions (e.g., adjacent a tissue surface of the intra-cardiac cavity), relatively higher flow regions (e.g., over the ports of the intra-cardiac cavity). It is noted that relatively lower blood flow regions in the intra-cardiac cavity may occur when a transducer is positioned in contact with a tissue surface to restrict blood flow at the contacted tissue. In some example embodiments, the relatively large number of transducers in the distribution advantageously allows for each of the transducers to be positioned adjacent their corresponding regions with little or no repositioning of the transducer-based device thereby facilitating obtaining transducer-based data concurrently from a multitude of locations in the bodily cavity. In this example embodiment, activation via the input-output device system of the control button **526** identified as "Map" can allow for other types of maps, including but not limited to, tissue contact maps, isochronal maps, isopotential maps, propagation maps, and various other voltage maps associated with intra-cardiac electrical activity.

Returning to the specific case of block **706** in FIG. **7A**, one or more of the above-discussed mapping procedures may be implemented according to instructions of block **706** to identify various regions **525** in the graphical representation that correspond to at least a portion of one or more anatomical features based at least on an analysis of the transducer data received according to block **704**. In some of these embodiments, the one or more anatomical features are the ports of various bodily openings (e.g., pulmonary veins, left lateral appendage, mitral valve) positioned in fluid communication with the intra-cardiac cavity and the transducer data includes data containing various blood flow data within the bodily cavity. In this embodiment, the instructions in block **706** include instructions that are configured to cause the input-output device system to display the identified regions **525** of the graphical representation **500**. In this example embodiment, the various ones of the identified regions **525** are shown in the three-dimensional graphical representation **500** provided by the graphical interface of FIG. **5C** and the two-dimensional graphical representation **500** provided by the graphical interface of FIG. **5D**.

In FIG. **5D**, the relatively large region **525a** is associated with the mitral valve, region **525b** is associated with the left lateral appendage, regions **525c** are associated with the left pulmonary vein group and regions **525d** are associated with the right pulmonary vein group. Each of the regions **525** is depicted in the graphical representation **500** with a graduated pattern provided by the flow identifier **527** in the graphical interface of FIG. **5D**. A graduated pattern can be employed to indicate various regions in the graphical representation corresponding to different regions of flow in the intra-cardiac cavity. The identified regions **525** may be identified by any suitable methods including the use of gray-scale patterns, different colors, different opacities, different intensities and different shapes. It is understood that other embodiments may employ other techniques to identify regions in the graphical representation corresponding to a desired anatomical feature. For example, transducer-based data containing blood and tissue impedance information may be employed to determine regions **525**. As previously discussed in this detailed description, a selection box **522** may be optionally enabled to allow for the selective inclusion in the graphical representation of graphical elements associated with various anatomical features associated with regions **525**.

Identification of the regions **525** may be motivated for various reasons. For example, in embodiments in which transducers of transducer-based device are activated to treat

or diagnose various regions in a bodily cavity, the identification of various regions 525 and their spatial relationship relative to one another may impact the efficacy of the treatment or diagnostic procedure. For example, in situations in which at least some of the transducers of a transducer-based device are employed to ablate various regions within an intra-cardiac cavity (e.g., to treat atrial fibrillation), ablation of a pulmonary vein may result in an undesired condition referred to as pulmonary stenosis. Identification of regions 525c, 525d in the graphical representation may be employed to reduce occurrences of this undesired condition.

In some embodiments, contrary to what is shown in FIG. 7A, block 706 immediately precedes block 710, with block 707, block 708, or both omitted. However, in some embodiments, block 707 is between blocks 706 and 710 as shown in FIG. 7A. In addition, in some embodiments, block 707 need not occur between blocks 706 and 710 as shown in FIG. 7A, and can, for example, instead occur immediately after block 704, with block 710 immediately following and block 706 omitted. Similarly, in some embodiments, block 708 is between blocks 706 and 710 as shown in FIG. 7A. However, in some embodiments, block 708 need not occur between blocks 706 and 710 as shown in FIG. 7A, and can, for example, instead occur immediately after block 704, with block 710 immediately following and block 706 omitted.

In any event, regarding block 707 and block 710, concurrent selection of a set of two or more of the transducers in the transducer-based device (e.g., a pair of adjacent transducers 306) is provided in some embodiments for enhanced workflows that are less cumbersome and more expeditious than those associated with non-concurrent selection of each transducer of the set of two or more of the transducers. For example, in some embodiments, a user-based selection of a between graphical element (e.g., between graphical elements 504 or 604) allows for a machine-based concurrent selection of an associated set of two or more transducers in various embodiments.

In this regard, block 707 includes, in some embodiments, identification instructions (e.g., instructions provided in a program) configured to cause identification of which of the respective transducers of each of various sets of two or more of the transducers of a transducer-based device are and which are not acceptable for concurrent selection.

Concurrent selection or non-concurrent selection of the respective transducers of a given one of the sets of two or more of the transducers may be motivated for various reasons. For example, concurrent selection of transducers may lead to a more expeditious workflow that advantageously reduces diagnostic or treatment times. Conditions, however, may not allow for the concurrent selection of the respective transducers of each of various ones of selectable sets of two or more transducers.

For example, if a transducer of a transducer pair is deemed not-activation-ready (e.g., according to the instructions of block 708 or block 804, discussed below), the transducer pair can be deemed, according to the instructions of block 707, to be a transducer set that is not acceptable for concurrent selection. A set of two or more transducers (e.g., a pair of transducers) that is identified (e.g., via instructions of block 708 or block 804, discussed below) as including at least one not-activation-ready transducer of the transducer-based device (e.g., a not-ablation-ready transducer) may, in some embodiments, be deemed, according to the identification instructions of block 707, as a set of two or more of the transducers of a transducer-based device whose respective transducers are not acceptable for concurrent selection. In some embodiments, a set of two or more of the transducers that is identified (e.g., via

instructions of block 708 or block 804, discussed below) as not including any not-activation-ready transducer of the transducer-based device (e.g., a not-ablation-ready transducer) may be deemed, according to the identification instructions of block 707, as a set of two or more of the transducers whose respective transducers are acceptable for concurrent selection.

The identification instructions of block 707 need not be limited to causing identification of a set of two or more transducers as acceptable or not acceptable for concurrent selection, and need not be limited to determining the acceptability of concurrency of selection based upon a determination of activation-ready transducers (e.g., via instructions of block 708 or block 804, discussed below). In some embodiments, the identification instructions of block 707 include instructions configured to cause, at least in part, the identification of the respective transducers of each of the sets of two or more transducers which are acceptable for concurrent selection based at least on an analysis of transducer data received in accordance with the instructions of block 704. In other words, acceptability of the concurrency of selection can be determined on a transducer-group basis or on an individual-transducer basis. These differing approaches can lend themselves to different circumstances. For example, in some situations, it may be preferable to determine whether an entire group of transducers is acceptable for concurrent selection, while in other situations, it may be beneficial to know whether individual transducers in each group are acceptable for concurrent selection.

In some embodiments, each of the sets of two or more of the transducers of the transducer-based device including a pair of adjacent transducers that are spaced with respect to one another across a corresponding region of space, each region of space not including any transducer. In some of these embodiments, a determination of whether or not one of these regions of space is acceptable for activation by its corresponding respective transducer pair is used as a basis for determining whether or not the respective transducer pair is acceptable for concurrent selection. For example, if the region of space is deemed to be acceptable for activation by the corresponding respective transducer pair, then the respective transducer pair is identified as being acceptable for concurrent selection in some embodiments. In some embodiments, the regions of space are determined to be acceptable for activation of the corresponding respective transducers according to determination instructions (e.g., according to some embodiments of the instructions of block 708 in FIG. 7A or block 804 in FIG. 8, discussed below). In this regard, the identification instructions of block 707 may be further configured to cause, at least in part, the identification of the respective transducers of each of the pairs of adjacent ones of the transducers which are acceptable for concurrent selection as the respective transducers of each of the plurality of pairs of adjacent transducers whose corresponding regions of space have been determined, according to determination instructions (not shown, but similar to the instructions of block 708 or block 804, discussed below) to be acceptable for activation of the corresponding respective transducers, and cause, at least in part, the identification of the respective transducers of each of the pairs of adjacent ones of the transducers which are not acceptable for concurrent selection as the respective transducers of each of the plurality of pairs of adjacent transducers whose corresponding regions of space have been determined, according to the determination instructions (not shown, similar to the instructions of block 708 or block 804, discussed below) to be not acceptable for activation of the corresponding respective transducers.

Acceptability of concurrency of selection of transducers or a region of space corresponding to transducers need not be based on or solely on a determination of the acceptability of activation of the corresponding transducers (e.g., pursuant to instructions according to block 708 or block 804, discussed below) in some embodiments. In this regard, transducers or regions of space each corresponding to transducers can be deemed to be acceptable or not acceptable for concurrent selection, according to various embodiments of the instructions of block 707, based on any reason which might make it beneficial or not beneficial to concurrently select the corresponding transducers.

In some embodiments, a result of one or more of the identifications according to the instructions of block 707 is the distinguishing display (e.g., by different visual characteristics) of graphical elements associated with transducers identified to be acceptable for concurrent selection as compared to graphical elements associated with transducers identified to be not-acceptable for concurrent selection. In this regard, the instructions according to block 707 include, in some embodiments, instructions configured to cause the graphical representation displayed according to the instructions of block 702 to visually distinguish its graphical elements associated with transducers identified to be acceptable for concurrent selection as compared to graphical elements associated with transducers identified to be not-acceptable for concurrent selection. In this regard, any instructions according to block 707 that affect the appearance of the graphical representation can be considered to be part of block 702 in some embodiments. The same applies to block 708 (with respect to block 702) in FIG. 7A, block 804 (with respect to block 802) in FIG. 8, block 812 (with respect to block 802) in FIG. 8, block 910 (with respect to block 902) in FIG. 9, block 912 (with respect to block 902) in FIG. 9, discussed below, and any other similar discussions herein, where distinguishing visual characteristics of graphical elements in a graphical representation facilitate differences in information or status.

To elaborate with respect to block 702 for example purposes only, various graphical element sets may be displayed by the display instructions of block 702, each graphical element set including one or more graphical elements (e.g., graphical elements 501 or 601) and each graphical element set associated with a respective one of a number of sets of two or more of the transducers (e.g., transducers of transducer-based devices 200, 300 or 400). Method 700 may include instructions (e.g., instructions provided in a program), (not shown) configured to cause graphical representation instructions of block 702 to cause the input-output device system (e.g., input-output device system 120 or 320) to display each of the graphical element sets associated with each of the sets of two or more of the transducers whose respective transducers have been identified (e.g., according to identification instructions associated with block 707) to be acceptable for concurrent selection with a respective set of visual characteristics that distinguishes each of the graphical element sets associated with each of the sets of two or more of the transducers whose respective transducers have been identified to be not acceptable for concurrent selection. Differences in the displayed visual characteristics may include different colors, opacities, hues, intensities, shading, patterns, shapes or the addition or removal of any displayed information suitable for distinguishing a concurrently-selectable transducer set from a not-concurrently-selectable transducer set.

For example, in some embodiments associated with FIGS. 5C and 5D, only the between graphical elements 504 that are each associated with a corresponding set of transducers (e.g., a corresponding pair of transducers in this embodiment) whose respective transducers are deemed acceptable for concurrent selection are displayed, and between graphical elements 504 that are associated with a corresponding pair of transducers that include at least one transducer that is deemed not acceptable for concurrent selection is not displayed. The presence or absence of a particular graphical element (e.g., a between graphical element 504) may form at least part of differences associated with displayed visually characteristics referenced in block 707.

In various embodiments of FIGS. 5C and 5D, the absent between graphical elements 504 indicate that their respective pairs of transducers each have been identified (e.g., according to the instructions of block 708, discussed below) to be over a region of space that is deemed unacceptable for activation (e.g., ablation) because such regions of space include a portion of a port of a bodily opening, which, in some embodiments, is not acceptable for ablation. These identifications lead to a conclusion, in some embodiments, (e.g., according to the instructions of block 707), that these respective pairs of transducers are not acceptable for concurrent selection in some embodiments. In some of these embodiments, such as those illustrated by FIGS. 5C and 5D, the graphical elements associated with these respective transducer pairs identified not to be acceptable for concurrent selection, are not displayed so that they are visually distinguished from the between graphical elements 504, which are displayed and which are associated with respective transducer pairs that have been identified to be acceptable for concurrent selection according to the instructions of block 707.

One reason for identifying a transducer set as being not-acceptable for concurrent selection according to the instructions of block 707 is that the transducer set, when activated, could be harmful to an affected region of space. However, other factors may also have a bearing on whether the respective transducers of a particular set of two more of the transducers are deemed concurrently selectable. In addition, combinations of different factors may be considered in the determination of whether the respective transducers of a particular set of two or more of the transducers are, or are not, acceptable for concurrent selection.

By way of a non-limiting example, another reason for determining a transducer set to be not-acceptable for concurrent selection, according to some embodiments of the instructions of block 707, is that transducers in the transducer set are too far apart, such that, for example, activation of the transducers in the set would lead to a result that may be considered ineffective. For example, if a transducer pair is too far apart, ablation performed by the pair might not be able to reliably form an electrophysiological conduction block between them.

The embodiments of FIG. 5J illustrate examples of transducer pairs being too far apart and, therefore, being deemed to be unacceptable for concurrent selection according to some embodiments of the instructions of block 707. In this regard, FIG. 5J illustrates a graphical interface including a graphical representation 500 provided by an input-output device system (e.g., input-output device system 120 or 320) according to some embodiments. Graphical representation 500 in FIG. 5J is similar to the graphical representation 500 in FIG. 5A and includes a plurality of graphical elements including various transducer graphical elements and between graphical elements. For convenience of discussion, the plurality of graphical elements of graphical representation 500 are iden-

tified as graphical elements **501**, the plurality of transducer graphical elements of graphical representation **500** are identified as transducer graphical elements **502**, and the between graphical elements of graphical representation **500** are identified as between graphical elements **504**. The graphical elements **501** in graphical representation **500** in FIG. **5J** are arranged in a plurality of rows **510** (e.g., latitudinal rows) and a plurality of columns **512** (e.g., longitudinal columns) in a manner similar to that shown by graphical representation **500** in FIG. **5A**. The transducer graphical elements **502** and between graphical elements **504** in graphical representation **500** in FIG. **5J** have similar associations with a spatial distribution of transducers (e.g., transducers **306** in FIG. **3A, 3B**) as their counterparts in graphical representation **500** in FIG. **5A**.

In this illustrated embodiment, graphical representation **500** in FIG. **5J** is distinguished from graphical representation **500** in FIG. **5A** in various ways including an absence of a between graphical element **504** between the respective transducer graphical elements **502** of various adjacent pairs of the transducers graphical elements **502**. For example, a between graphical element **504** is not displayed between adjacent transducer graphical elements **502d** and **502e**. In this illustrated embodiment, an absence of between graphical elements **504** occurs in some of the rows **510**. In this illustrated embodiment, the presence or absence of a particular between graphical element **504** in the graphical representation **500** in FIG. **5J** is indicative, at least in part, of differences in the visual characteristics of particular graphical elements **501** associated with sets of two or more transducers whose respective transducers have been identified by the instructions of block **707** to be acceptable for concurrent selection and particular graphical elements **501** associated with sets of two or more transducers whose respective transducers have been identified by the instructions of block **707** to be not acceptable for concurrent selection. In various example embodiments, between graphical elements **504** are displayed between corresponding pairs of transducer graphical elements **502** associated with transducers that have been identified by the instructions of block **707** to be acceptable for concurrent selection, while between graphical elements **504** are not displayed between corresponding pairs of transducer graphical elements **502** associated with transducers that have been identified by the instructions of block **707** to be not acceptable for concurrent selection.

In some example embodiments, the instructions **707** are further configured to cause, at least in part, the identification of the respective transducers of each of the pairs of adjacent ones of the transducers in a distribution which are acceptable for concurrent selection as the respective transducers of each of the plurality of pairs of adjacent ones of the transducers in the distribution having a respective transducer-to-transducer distance that is not greater than a target transducer-to-transducer distance, and cause identification, at least in part, of the respective transducers of each of the pairs of adjacent ones of the transducers in the distribution which are not acceptable for concurrent selection as the respective transducers of each of the plurality of pairs of adjacent ones of the transducers in the distribution having a transducer-to-transducer distance that is greater than the target transducer-to-transducer distance. In embodiments involving relatively low temperature ablations, the target transducer-to-transducer distance might be one-half an electrode width. In embodiments involving relatively higher temperature ablations, larger target transducer-to-transducer distances might be sufficient. In various embodiments, ablation temperatures lower than the thermal coagulation temperature of blood are preferred. Other factors that may impact the target transducer-to-transducer distance

might include tissue thickness, tissue type, characteristics of fat layers embedded in the tissue, the blood's susceptibility to forming coagulum, and whether or not a pair of transducers performing the ablation are separated by a physical portion of the transducer-based device, such as by an elongate member **304**. In some embodiments, a target transducer-to-transducer distance associated with a particular pair of the transducers is determined or selected to increase a likelihood that an electrophysiological conduction block that blocks electrophysiological activity between the particular pair of transducers will be formed in tissue upon activation of the transducers. In some embodiments, concurrent selection of a pair of transducers whose activation would not likely result in a desired electrophysiological conduction block may be deemed unacceptable according to the instructions of block **707**.

It is noted that different target transducer-to-transducer distances may be employed for different pairs of the transducers. For example, a first target transducer-to-transducer distance associated with a pair of transducers spaced with respect to one another over a region of space that includes a physical portion of a structure on which the transducers are located (e.g., structure **308**) may be different (e.g., greater) than a second target transducer-to-transducer distance associated with a pair of transducer that are spaced with respect to one another across a region of space that does not include a physical portion of a supporting structure (e.g., structure **308**). In the embodiments of FIG. **5J**, between graphical elements **504** are not displayed between transducers graphical elements **502** arranged in particular ones of the rows **510** having the greatest depicted spacing between adjacent transducer graphical elements **502**.

In some particular embodiments, between graphical elements **504** are not displayed between transducer graphical elements **502** arranged in rows **510a** and **510b**, because the transducer-to-transducer distances of the transducers (e.g., transducers **306**) corresponding to these transducer graphical elements **502** in these rows each exceeds a target distance (e.g., in use). Therefore, in some embodiments, it is determined (e.g., according to the instructions of block **707**) that the transducers corresponding to the transducer graphical elements **502** along rows **510a** and **510b** are not acceptable for concurrent selection, which results in the non-display of the corresponding between graphical elements **504**. However, between graphical elements **504** are displayed between transducer graphical elements **502** arranged in the other rows (including row **510c**), because the transducer-to-transducer distances of the transducers corresponding to these transducer graphical elements **502** in these rows each are within a target distance. Therefore, in some embodiments, it is determined (e.g., according to the instructions of block **707**) that the transducers corresponding to the transducer graphical elements **502** along the other rows (besides rows **510a** and **510b**) are acceptable for concurrent selection, which results in the display of the corresponding between graphical elements **504**.

It should be noted that although the embodiments of FIG. **5J** illustrate the unacceptability of concurrency of selection of various transducer pairs latitudinally arranged on a supporting structure due to excessive transducer-to-transducer distance, acceptability of concurrency of selection of transducer pairs or larger groups can be determined on an individual transducer-group basis and based on other factors or other factors in conjunction with transducer-to-transducer distance. For example, a transducer-based device (e.g., similar to transducer-based device **300**) represented by a graphical representation in FIG. **5J** may contort when placed in a bodily cavity, and therefore, transducer-to-transducer distances may

vary between transducer pairs in some directions (e.g., across regions of space that do not include a physical portion of the supporting structure). Therefore, in some embodiments, the transducer-to-transducer distances are calculated in real time for each possible transducer pair via transducer data received according to the instructions of block 704, and based at least upon this transducer data, each possible transducer pair is identified as being acceptable or not acceptable for concurrent selection according to the instructions of block 707, and the corresponding between graphical elements are consequently displayed or not displayed in the graphical representation. In some embodiments, a particular transducer pair is identified as being acceptable or not acceptable for concurrent selection according to the instructions of block 707 on the basis of other factors in addition to the transducer-to-transducer distance associated with the particular transducer pair (e.g., location of the transducer pair to a particular anatomical feature).

Further, in some embodiments, acceptability of concurrency of selection need not be performed on a transducer-pair-basis. For example, in some of these embodiments, a group of three or more transducers that could form one possible ablation path could be evaluated as a group to determine whether all transducers within that group are acceptable for concurrent selection, e.g., to determine whether a possible ablation path is acceptable of activation (e.g., ablation). In this regard, in some embodiments, the instructions of block 707 are configured to cause identification, for each of a plurality of transducer sets of three or more transducers (e.g., each representing a possible ablation path), whether or not all transducers within the corresponding transducer set are acceptable for concurrent selection.

Having discussed the identification of transducer sets that are acceptable and transducer sets that are not acceptable for concurrent selection according to the instructions of block 707, a discussion of some embodiments of graphical element selection and activation according to the instructions of blocks 710 and 712 in FIG. 7A will now be discussed with respect to FIG. 7B.

FIG. 7B includes an exploded view of the selection instructions of block 710 and the activation instructions of block 712 according to some example embodiments. In some embodiments, all of the blocks shown in FIG. 7B may not be required. Block 710A includes first selection instructions (e.g., instructions provided in a program) configured to cause selection (e.g., a first selection) of at least one graphical element in a first graphical element set of a plurality of graphical element sets. In some embodiments, the first graphical element set is associated with a first one of the sets of two or more of the transducers whose respective transducers have been identified according to the instructions of block 707 to be acceptable for concurrent selection, and the first selection instructions are configured to cause concurrent selection, in response to the selection of the at least one graphical element in the first graphical element set, of the respective transducers of the first one of the sets of two or more of the transducers. However, identification of the respective transducers as acceptable for concurrent selection, and concurrent selection of the respective transducers may not be required in some embodiments.

For example, a user might directly select a between graphical element such as a between graphical element 504 or 604 (i.e., the between graphical element is a user-selected between graphical element), which might cause the first selection instructions to cause the data processing device system to (a) perform a machine-selection of the user-selected between graphical element (e.g., by changing its visual

characteristics), and (b) perform a machine-selection (or in some embodiments, a concurrent selection) of the transducers in a transducer pair corresponding to the user-selected between graphical element. In some embodiments, the transducer pair is identified to be acceptable for concurrent selection. In some embodiments, the machine-based selection of the transducer pair may lead to an activation (or in some embodiments, a concurrent activation) of the transducers of that pair (e.g., block 712A, discussed below). In some embodiments, including, but not limited to embodiments where the user directly selects a between graphical element (i.e., the between graphical element is user-selected), the machine-selection(s) may or may not include a machine-selection of a transducer graphical element. In some embodiments, the first selection does not include a user-selected transducer graphical element. In some embodiments, including, but not limited to embodiments where the user directly selects a between graphical element, the selection of the at least one graphical element in the first graphical element set according to the instructions of block 710A is a selection, at one time, of each of the at least one graphical element in the first graphical element set. For example, the user directly selects, at one time, a between graphical element via a mouse click with the cursor above the between graphical element, which causes a corresponding machine selection, at one time, of the user-selected between graphical element, e.g., by changing a visual characteristic of the user-selected between graphical element. Although the above-discussion regarding block 710A includes examples involving both a user graphical element selection and a machine graphical element selection, some embodiments involve only a machine graphical element selection at block 710A.

Block 710B includes second selection instructions configured to cause selection (e.g., a second selection as opposed to the first selection discussed above with respect to block 710A) of at least one graphical element in a second graphical element set of the graphical element sets. In some embodiments, the second graphical element set is associated with a second one of the sets of two or more of the transducers whose respective transducers have been identified according to the instructions of block 707 to be not acceptable for concurrent selection, and the second selection instructions are configured to cause non-concurrent selection, in response to the selection of the at least one graphical element in the second graphical element set, of the respective transducers of the second one of the sets of two or more of the transducers. However, identification of the respective transducers as not acceptable for concurrent selection, and non-concurrent selection of the respective transducers are not required in some embodiments. In some embodiments, the selection of the at least one graphical element in the second graphical element set is a selection, over a time interval, of at least two of the graphical elements in the second graphical element set.

For example, a user might directly select a first transducer graphical element such as a first transducer graphical element 502 or 604 (i.e., the first transducer graphical element is a user-selected transducer graphical element), which might cause the second selection instructions to cause the data processing device system to (a1) perform a selection (or machine selection) of the user-selected first transducer graphical element (e.g., by changing its visual characteristics), and (b1) select the transducer corresponding to the user-selected first transducer graphical element. Then, the user might directly select a second transducer graphical element such as a second transducer graphical element 502 or 604 (i.e., the second transducer graphical element is a user-selected transducer graphical element), which might cause the second selection

instructions to cause the data processing device system to (a2) perform a selection (or machine selection) of the user-selected second transducer graphical element (e.g., by changing its visual characteristics), and (b2) select the transducer corresponding to the user-selected second transducer graphical element. Accordingly, in some embodiments, the user-selections of the first and second transducer graphical elements over a time interval cause the corresponding machine-selections of the first and second transducer graphical elements over a time interval. In some embodiments, these machine selections (b1) and (b2) of the transducers corresponding to the user-selected first and second transducer graphical elements are non-concurrent selections. In some embodiments, the machine-based selections (b1) and (b2) of the transducers corresponding to the user-selected first and second transducer graphical elements may lead to an activation (or in some embodiments, a non-concurrent activation) of such transducers (e.g., block 712, discussed below).

In some embodiments, the second graphical element set selected according to the instructions of block 710B has a different number of graphical elements than the first graphical element set selected according to the instructions of block 710A. For example, the second graphical element set selected according to the instructions of block 710B could include two transducer graphical elements 502, while the first graphical element set selected according to the instructions of block 710A could include, in some embodiments, only a between graphical element 504 or, in other embodiments, two transducer graphical elements 502 and a between graphical element 504.

Block 712A shown in FIG. 7B includes activation instructions (e.g., instructions provided in a program) configured to cause activation of the transducers corresponding to the first graphical element set selected according to the instructions of block 710A. Block 712B shown in FIG. 7B includes activation instructions (e.g., instructions provided in a program) configured to cause activation of the transducers corresponding to the second graphical element set selected according to the instructions of block 710B.

In some embodiments, the activation instructions of block 712A include activation instructions configured to, in response to the concurrent selection of the respective transducers of the first one of the sets of two or more of the transducers cause concurrent activation, via the input-output device system (e.g., input-output device system 120 or 320), of each of the respective transducers of the first one of the sets of two or more of the transducers. In some embodiments, the concurrent activation may include monopolar activation of each of the respective transducers of the first one of the sets of two or more of the transducers. In some embodiments, the concurrent activation may include bipolar activation between the respective transducers of the first one of the sets of two or more of the transducers. The monopolar or bipolar activation of the respective transducers of the first one of the sets of two or more of the transducers may include sufficient energy being delivered from an energy source device system (e.g., energy source device system 340) to each of the respective transducers of the first one of the sets of two or more of the transducers, the energy sufficient to cause ablation of tissue in a bodily cavity. In some of these embodiments, conditions allow for the energy to be sufficient to cause an electrophysiological activity conduction block to be formed in the tissue between the respective transducers of the first one of the sets of two or more of the transducers.

In some embodiments, the activation instructions of block 712B include second activation instructions configured to, in response to the non-concurrent selection of the respective

transducers of the second one of the sets of two or more of the transducers cause non-concurrent activation, via the input-output device system, of each of the respective transducers of the second one of the sets of two or more of the transducers. In some embodiments, the activation instructions of block 712B include second activation instructions configured to, in response to the non-concurrent selection of the respective transducers of the second one of the sets of two or more of the transducers, preclude bipolar activation, via the input-output device system, between the respective transducers of the second one of the sets of two or more of the transducers. In various embodiments, selection instructions (e.g., the selection instructions of block 808) allow for the concurrent selection of a pair of transducers by the selection of a particular between graphical element 504 made in accordance with various aspects of method 700.

In some embodiments associated with FIG. 7B, a first selection of at least one of the graphical elements 501 (e.g., between graphical element 504a shown in FIG. 5F, for example) from a first graphical element set is caused according to first selection instructions (e.g., instructions of block 710A) to select a first pair of transducers made up of a first transducer and a second transducer (e.g., transducers 306). FIG. 5J is considered to include a group of transducer graphical elements 502, and in some of these embodiments, the first selection may not include a user selection of any user-selected transducer graphical elements 502 in the group (e.g., the first selection could be for the between graphical element 504a in cases where the first selection is only for transducer pairs deemed to be concurrently selectable according to the instructions of block 707).

In some embodiments, a second selection of at least one of the graphical elements 501 in FIG. 5F is caused according to second selection instructions (e.g., instructions of block 710B) to select a second pair of the transducers made up of the first transducer and a third transducer. For example, in some embodiments, the second selection may not include a user selection of any user-selected transducer graphical elements 502 (e.g., the second selection could be for the between graphical element 504d in cases where the second selection is only for transducer pairs deemed to be concurrently selectable according to the instructions of block 707). In some embodiments, the second selection may not include a user selection of any user-selected between graphical elements 504 (e.g., the second selection could be for at least a selected transducer graphical element (e.g., transducer graphical element 502f shown in FIG. 5F) in cases where the second selection is only for transducer pairs deemed to be not-concurrently selectable according to the instructions of block 707). In various embodiments, each of the first, the second, and the third transducers are different transducers which respectively correspond to transducer graphical elements 502a, 502b and 502f. In various embodiments, each of the first pair of transducers and the second pair of transducers (each selected by respective ones of the first selection according to the instructions of block 710A and the second selection according to the instructions of block 710B, for example) is an adjacent pair of transducers in a distribution of transducers. In some embodiments, the second selection includes a selection of at least two transducer graphical elements in the group (e.g., transducer graphical elements 502f and 502a).

As stated above, a first spatial relationship between the plurality of transducer graphical elements 502 in the graphical representation of FIG. 5F, for example, may be consistent with a second spatial relationship between corresponding ones of the transducers in the distribution. In some embodiments, each of between graphical elements 504a and 504d is

associated with a respective region of space that does not include a physical portion of a structure on which the transducers are located (e.g., structure 308). In other embodiments, at least one of the first pair and the second pair of transducers may correspond to a between graphical element 504 that is associated with a region of space that includes a physical portion of the structure. Such distinctions can be important, as discussed herein, in determining the acceptability of concurrency of selection of graphical elements and transducers, the acceptability of activation of transducers, the duration of activation, and for other reasons discussed herein.

As discussed above, the selections according to the instructions of blocks 710A and 710B can occur by way of any combination of one or more machine-based constituent selections and, optionally or additionally, user-based constituent selections. In some embodiments, each of the first selection (e.g., according to the instructions of block 710A) and the second selection (e.g., according to the instructions of block 710B) includes a user-selected graphical element 501 selected by a user according to a user instruction (e.g., a user-based constituent selection, as discussed above) to select the user-selected graphical element 501. In some embodiments, the first selection, the second selection, or each of the first selection and the second selection does not include a selection of a user-selected transducer graphical element 502 made in response to a user instruction to select the transducer graphical element. For instance, a user may instruct selection of a between graphical element 504, which can cause a machine-based selection of a pair of transducer graphical elements 502 that correspond to the user-selected between graphical element 504, and, optionally, a machine-based selection of a pair of transducers that correspond to the pair of transducer graphical elements 502. In some embodiments, the second selection does not include a selection of a user-selected transducer graphical element 502 made in response to a user instruction to select the transducer graphical element.

While in some embodiments, both the first selection (e.g., according to the instructions of block 710A) and the second selection (e.g., according to the instructions of block 710B) do not include a selection of a user-selected transducer graphical element made 502 in response to a user selection to select the user-selected transducer graphical element 502, in other embodiments, the second selection may include a selection of at least one user-selected between graphical element 504 (e.g., 504d) (e.g., made in response to a user-instruction to select the at least one user-selected between graphical element).

Block 710C shown in FIG. 7B includes third selection instructions employed in some embodiments, the third selection instructions configured to, in response to receiving a user instruction to select at least one user-selected graphical element, cause the data processing device system (e.g., data processing device system 110 or 310) to a select at least one other graphical element. In one particular embodiment, the third selection instructions are configured to cause the data processing device system to select at least a second graphical element (e.g., transducer graphical elements 502a and 502b) in response to a user instruction to select between graphical element 504a. In this particular embodiment, the third selection instructions are configured to select at least a third graphical element (e.g., transducer graphical elements 502a and 502b) in response to a user instruction to select the user-selected between graphical element 504d. Visual characteristics of user-selected graphical elements and graphical elements selected by the data processing device system in response to receiving a user instruction to select at least one

user-selected graphical element may be changed as discussed above. In some embodiments, the first activation instructions of block 712A, the second activation instructions of block 712B or each of the first and the second activation instructions include instructions configured to cause activation of a corresponding one of the sets of two or more of the transducers in response to the selection of at least one graphical element made by the data processing device system in response to at least receiving a user instruction to select at least one user-selected graphical element.

Having discussed identifying the acceptability of concurrency of selection of transducer sets with respect to block 707 and corresponding subsequent selection of transducer graphical elements and activation of corresponding transducers pursuant to FIG. 7B, block 708 in FIG. 7A will now be described. Block 708 can include, in some embodiments, instructions provided by a program to cause the data processing device system to identify activation-ready transducers and not-activation-ready transducers based at least upon an analysis of transducer data (e.g., received according to the instructions of block 704). For example, in some embodiments, if the analysis of the transducer data indicates that certain transducers are located above an anatomical feature that should not be ablated, those certain transducers are identified according to the instructions of block 708 to be not-activation-ready transducers. Another example of not-activation-ready transducers includes those that have insufficient contact with tissue to properly ablate or acquire tissue characteristics, as determined, for example, according to measurements (e.g., various electrical, force, or pressure measurements) represented in the transducer data. The instructions according to block 708 include, in some embodiments, instructions configured to cause the graphical representation displayed according to the instructions of block 702 to visually distinguish the not-activation-ready transducers from the activation-ready transducers.

In this regard, block 708 includes, in some embodiments, instructions (e.g., identification instructions) provided by a program configured to cause the data processing device system to identify activation-ready transducers of the transducer-based device as transducers deemed, based at least on an analysis of the transducer data (e.g., received according to the instructions of block 704), acceptable for activation (e.g., activation according to the instructions of block 712), and not-activation-ready transducers of the transducer-based device as transducers deemed, based at least on the analysis of the transducer data, not acceptable for activation (e.g., activation according to the instructions of block 712).

As discussed above, the identification of activation-ready transducers and not-activation-ready transducers of a transducer-based device in accordance with the instructions of block 708 can take different forms. In this regard, block 804 in FIG. 8 provides an example of the instructions of block 708 in FIG. 7A, according to some embodiments. It should be noted that block 802 corresponds to block 702 in some embodiments, blocks 806 and 808 correspond to block 710 in some embodiments, and block 810 corresponds to block 712 in some embodiments. However, in some embodiments, FIG. 8 stands on its own independently of FIG. 7A. In this regard, the method 800 pertains to ablation-causing activations, although it is understood that other forms of activation may be employed in other embodiments. Reference to at least some of FIG. 5 continues with the discussion of FIG. 8 for convenience of discussion. In some embodiments, method 800, like method 700, may include a subset of the associated blocks or additional blocks than those shown. In addition, in some embodiments, method 800, like method 700, may include a

different sequence between various ones of the associated blocks than those shown in FIG. 8.

The example of block **804**, in some embodiments, includes instructions (e.g., identification instructions provided by a program) configured to identify an activation-ready transducer of the transducer-based device (e.g., transducer-based devices **100, 300, 400**) as a transducer that is associated with or adjacent a region of space deemed, based at least on an analysis of the transducer data, acceptable for ablation. In some embodiments, this “adjacent region of space” is a region of space that includes matter that would be activated, ablated, or otherwise interacted with by the corresponding transducer due to ablation activation or other activation of the corresponding transducer. In some embodiments, a region of space is determined, in view of an analysis of the transducer data, to be acceptable for ablation or activation of a corresponding transducer set, when the region of space is not determined to be unacceptable for ablation or activation. In some embodiments, a region of space is determined, in view of an analysis of the transducer data, to be not acceptable for ablation or activation of a corresponding transducer set, when all or particular matter in the region of space may be negatively or unacceptably negatively impacted by the ablation or activation of the corresponding transducer set. In some embodiments, block **804** includes instructions (not shown, e.g., identification instructions provided by a program) configured to cause identification of an activation-ready transducer of the transducer-based device (e.g., transducer-based devices **100, 300, 400**) as a transducer that is deemed, based at least on an analysis of the transducer data, to be located within sufficient proximity to a region of space, the sufficient proximity deemed acceptable for ablation. In some embodiments, this sufficient proximity is deemed to require contact between the transducer and the tissue to be ablated.

In some embodiments, block **804** also includes instructions (e.g., identification instructions provided by a program) configured to identify a not-activation-ready transducer of the transducer-based device as a transducer that is adjacent a region of space deemed, based at least on the analysis of the transducer data, not acceptable for ablation. In some embodiments, block **804** includes instructions (not shown, e.g., identification instructions provided by a program) configured to identify a not-activation-ready transducer of the transducer-based device (e.g., transducer-based devices **100, 300, 400**) as a transducer that is deemed, based at least on an analysis of the transducer data, not within sufficient proximity to a region of space, the sufficient proximity deemed acceptable for ablation.

It is understood that a transducer may be identified as an activation-ready transducer or not-activation-ready transducer on the basis of other criteria in other embodiments. In some embodiments, activation-ready transducers are referred to as ablation-ready transducers and not-activation-ready transducers are referred to as not-ablation-ready transducers. In some embodiments, at least two of the ablation-ready transducers or at least two of the not-ablation-ready transducers may be located on a same structural member (e.g., an elongate member **304**) of a transducer-based device. In some embodiments, at least two of the ablation-ready transducers or at least two of the not-ablation-ready transducers may be located on different structural members (e.g., different elongate members **304**) of a transducer-based device. These differences can be important as transducers along a structural member may have different ablation characteristics than transducers located on different structural members that have no physical portion of the transducer based device between them. For example, ablation along structural members may

have, for example, different insulating effects on ablation as compared to ablation between structural members.

In some embodiments where the transducer-based device or a portion thereof is receivable or positionable in a bodily cavity, the instructions of block **804** may include instructions configured to require that, in order for a region of space to be deemed acceptable for ablation, the region of space be determined, based at least on the analysis of the transducer data (e.g., received according to the instructions of block **704**, which may be part of block **804** or between blocks **802** and **804** in some embodiments), to be associated with a tissue in the bodily cavity that is acceptable for ablation. The instructions of block **804** may include instructions configured to require that, in order for a region of space to be deemed not acceptable for ablation, the region of space be determined, based at least on the analysis of the transducer data, to be associated with a tissue in the bodily cavity that is not acceptable for ablation. In some embodiments, the bodily cavity is an intra-cardiac cavity and the tissue in the bodily cavity that is not acceptable for ablation is blood.

In some embodiments where the transducer-based device or a portion thereof is receivable or positionable in a bodily cavity, the instructions of block **804** may include instructions configured to require that, in order for a region of space to be deemed acceptable for ablation, the region of space be determined, based at least on the analysis of the transducer data, to be associated with an anatomical feature of the bodily cavity that is acceptable for ablation. The instructions of block **804** may include instructions configured to require that, in order for a region of space to be deemed not acceptable for ablation, the region of space be determined, based at least on the analysis of the transducer data, to be associated with an anatomical feature of the bodily cavity that is not acceptable for ablation (e.g., a pulmonary vein).

In some embodiments where the transducer-based device or a portion thereof is receivable or positionable in a bodily cavity that includes a tissue wall surface interrupted by one or more ports in fluid communication with the bodily cavity, the instructions of block **804** may include instructions configured to require that, in order for a region of space to be deemed not acceptable for ablation, the region of space be determined, based at least on the analysis of the transducer data, to overlie a least part of a port of the one or more ports.

Referring back to FIGS. **5C** and **5D**, the various regions **525** are associated with regions of space deemed not suitable or acceptable for ablation while various other regions of the graphical representation that exclude regions **525** are associated with regions of space deemed suitable for ablation in this illustrated embodiment. In some embodiments, like the above-discussion with respect to blocks **708** and **702**, regions of space deemed suitable for ablation can be visually distinguished from the regions of space deemed not suitable for ablation in the graphical representation displayed according to the instructions of block **802**. In this regard, the graphical representation instructions for visually distinguishing the regions of space deemed suitable for ablation from the regions of space deemed not suitable for ablation may reside in block **804** or in **802**, according to some embodiments. In any event, these graphical representation instructions (e.g., graphical representation instructions included in a program) may be configured, in some embodiments, to cause an input-output device system (e.g., input-output device system **120** or **320**) to display a graphical representation of at least a portion of a transducer-based device.

In some embodiments, like the above-discussion with respect to blocks **708** and **702**, the graphical representation instructions may include instructions configured to cause the

input-output device system to display the graphical elements **501** that are associated with transducer sets including the ablation-ready transducers with a first set of visual characteristics and to display the graphical elements **501** that are associated with transducer sets including the not-ablation-ready transducers with a second set of visual characteristics different than the first set of visual characteristics. In some embodiments, the first set of visual characteristics, the second set of visual characteristics, or both the first and the second sets of visual characteristics each includes a plurality of different visual characteristics. Different visual characteristics can include different colors, opacities, hues, intensities, shading, patterns, shapes or the addition or removal of any displayed information suitable for distinguishing an ablation-ready transducer from a not-ablation-ready transducer. In the embodiment of FIGS. **5C** and **5D**, transducer graphical elements **502** that are positioned over any of the regions **525** (e.g., transducer graphical elements **502** associated with not-ablation-ready transducers) are displayed with different visual characteristics (e.g., a thick line circle in this embodiment) than the transducers graphical elements **502** that are not positioned over any of the regions **525** (e.g., transducer graphical elements **502** associated with the ablation-ready transducers).

In the embodiment illustrated in FIGS. **5C** and **5D**, only the between graphical elements **504** that are each associated with a corresponding set of transducers (e.g., a corresponding pair of transducers in this embodiment) that includes only ablation-ready transducers are displayed. In the embodiment illustrated in FIGS. **5C** and **5D**, only the between graphical elements **504** that are each associated with a respective region of space that is located between a corresponding pair of transducers that includes only ablation-ready transducers are displayed. In the embodiment illustrated in FIGS. **5C** and **5D**, only the between graphical elements **504** that are each associated with a respective region of space that does not include any transducer and does not include any portion of a region of spaced deemed, based at least on the transducer data, not acceptable for ablation are displayed.

In the embodiment illustrated in FIGS. **5C** and **5D**, each of the between graphical elements **504** that is associated with a corresponding set of transducers (e.g., a corresponding pair of transducers in this embodiment) that includes at least one not-ablation-ready transducers is not displayed. In the embodiment illustrated in FIGS. **5C** and **5D**, each of the between graphical elements **504** that is associated with a region of space between a corresponding pair of transducers that includes at least one not-ablation-ready transducer is not displayed. In the embodiment illustrated in FIGS. **5C** and **5D**, each of the between graphical elements **504** that is associated with a region of space that does not include any transducer but does include a portion of a region of spaced deemed, based at least on the transducer data, not acceptable for ablation (e.g., a region **525**) is not displayed.

Moving on to a discussion of blocks **806** and **808** in FIG. **8**, which may correspond to block **710** in some embodiments, block **806** of method **800** includes ablation request instructions (e.g., instructions provided by a program) configured to cause the data processing device system (e.g., data processing device systems **110** or **310**) to process an ablation request received from the input-output device system, the ablation request configured to request ablation by at least some of the plurality of transducers of the transducer-based device.

In some embodiments, the ablation request associated with block **806** may be considered part of a selection of one or more graphical elements according to the instructions of block **710** in FIG. **7A** in some embodiments. Block **808**

represents instructions associated with such a selection according to some embodiments. As discussed above, the selection instructions associated with block **710** may configure the data processing device system to receive a selection, via the input-output device system (e.g., again exemplified by input-output device system **120** or **320**) of at least some of the graphical elements (e.g., graphical elements **501**, **601**) provided in the graphical representation. In some embodiments, the selection instructions associated with block **710** cause the data processing device system to receive, via the input-output device system, a selection of at least some of the graphical elements **501** associated with the transducers including activation-ready transducers. Block **808**, in some embodiments, includes selection instructions (e.g., instructions provided in a program), which configure the data processing device system (e.g., again exemplified by data processing device systems **110** or **310**) to cause selection of various graphical elements. In some embodiments, the caused selection includes receiving, via the input-output device system (e.g., again exemplified by input-output device systems **120**, **320**) a selection of the graphical elements **501** associated with at least some of the transducers, the at least some of the transducers including ablation-ready transducers. In some embodiments, each of the graphical elements **501** associated with the at least some of the transducers is independently selectable. For example, as shown in FIG. **5E**, first between graphical element **504a** positioned between the first and the second transducer graphical elements **502a**, **502b** respectively identified by identification labels **513** as “Q:6” and “R:6” has been selected via the input-output device system. In this example embodiment, the ablation request instructions of block **806** include the instructions of block **808**. In this example embodiment, the ablation request associated with the instructions of block **806** is made at least in part by making a selection of the at least some of the graphical elements **501** associated with the instructions of block **808**.

It is noted that in some embodiments (e.g., embodiments where ablation-ready transducers and not-ablation-ready transducers are selectable in accordance with blocks **806** or **808**), the method **800** may include determination instructions (e.g., instructions provided by a program) (not shown, but could be shown connected (immediately) downstream of block **806** and (immediately) upstream of block **822**) configured to cause the data processing device system to determine whether an ablation-requested transducer set including the at least some of the plurality of transducers selected in accordance with blocks **806** or **808** includes a not-ablation-ready transducer. In this case, the method **800** may include ablation denial instructions (e.g., instructions provided in a program) configured to, if it is determined according to the determination instructions that the ablation-requested transducer set includes the not-ablation-ready transducer, deny the ablation request. In some embodiments, the ablation denial instructions are configured to deny the ablation request at least with respect to the not-ablation-ready transducer in the ablation-requested transducer set if it is determined according to the determination instructions that the ablation-requested transducer set includes the not-ablation-ready transducer. In some embodiments, the ablation denial instructions can take a form of non-activation instructions (e.g., instructions provided by a program) associated with block **822** in FIG. **8**, which, in some embodiments, are configured to cause the data processing device system to prevent energy from the energy source device system from being delivered to each of the plurality of not-ablation-ready transducers identified according to block **804** or block **708**. An example of preventing energy from being delivered would be for the data processing device sys-

tem to reject all or a portion of an instruction received, for example, from a user via the input-output device system, to perform ablation involving not-ablation ready transducers.

Block **812** of method **800** includes instructions (e.g., instructions provided in a program) configured to, in response to receiving independent selections of graphical elements in accordance with block **808**, cause the input-output device system to change a visual characteristic of the selected graphical elements **501** during a time interval that occurs during the receiving of the independent selections, after a completion of the receiving of the independent selections, or both during the receiving of the independent selections and after a completion of the receiving of the independent selections. In some embodiments, the selected graphical elements **501** include a selected between graphical element **504a** as shown in FIG. **5E**. Changing the visual characteristic of the selected between graphical element **504a** may include changing a color, opacity, hue, intensity, shading, pattern, shape or the addition or removal of any displayed information suitable for indicating that the selection has occurred. In this embodiment, the selected between graphical element **504a** is modified to include an elongated graphical portion **530** having differing visual characteristics. In some embodiments, block **812** can include additional instructions configured to cause the input-output device system to change a visual characteristic of at least one (e.g., both in this illustrated embodiment) of the first and the second transducer graphical elements **502a**, **502b** respectively identified by identification labels **513** as “Q:6” and “R:6” during the time interval. In this example embodiment a thicker border is provided around each of the first and the second transducer graphical elements **502a**, **502b** upon receiving the selection.

In a similar fashion, a visual characteristics of others of the graphical elements **501** (e.g., including transducer graphical elements **502**) may change upon their selection in accordance with the instructions of block **808**. For example, as shown in FIG. **5F** additional between graphical elements **504** (e.g., including second between graphical **504b**) have been selected in accordance with the instructions of block **808** with the visual characteristics of the selected additional between graphical elements **504** changing in accordance with the instructions of block **812**. For clarity, only the identification labels **513** associated with the transducer graphical elements **502** associated with the pair of transducers associated with each of the selected between graphical elements **504** is shown in FIGS. **5E** and **5F**. In this illustrated embodiment, each of the selected between graphical elements **504** in FIGS. **5E** and **5F** were independently selected.

It should be noted that, although the above discussion regarding changing of visual characteristics occurs within the context of FIG. **8**, block **812**, such discussion can also apply to any discussions herein regarding changing of visual characteristics in some embodiments.

Block **814** of method **800** includes instructions (e.g., instructions provided in a program) configured to cause the input-output device system to display a respective electrogram **535** (only two called out in each of FIGS. **5E** and **5F**) for each transducer of the pair of transducers associated with each of the selected between graphical elements **504** (e.g., selected according to the instructions of block **808** or **710**). In this example embodiment, each electrogram **535** is identified with an identifier **536** that provides information corresponding to the identification label **513** associated with a respective one of the transducer graphical elements **502**. In this example embodiment, each electrogram **535** is provided on the basis of transducer data provided by a transducer of the respective pair of transducers associated with a selected between graphical

element **504**. In this example embodiment, a single electrogram **535** would also be displayed if a transducer graphical element **502** were to be individually selected, the single electrogram **535** being provided on the basis of transducer data provided by the respective transducer associated with the selected single transducer graphical element **502**. In some example embodiments, block **814** includes instructions configured to cause the input-output device system to display a combined electrogram (e.g., a bipolar electrogram) from the pair of transducers associated with each of the selected between graphical elements **504**. It is noted that some of the electrograms **535** not shown in the graphical representation shown in FIG. **5F** may be viewed by operation of scroll bar **528** via the input-output device system. It is also noted that, although block **814** is shown as immediately following an ablation request according to block **806**, block **814**, in some embodiments, is not dependent upon receipt of an ablation request, and may operate independently any time a graphical element is selected.

Block **816** of method **800** includes path-display instructions (e.g., instructions provided in a program) configured to, in response to receiving the independent selections (e.g., selected according to the instructions of block **808** or **710**) of between graphical elements **504**, cause the graphical representation to include a displayed visual representation of a path **537** passing through at least a portion of each of the selected between graphical elements **504**, during a time interval that occurs (a) during the receiving of the independent selections, (b) after a completion of the receiving of the independent selections, or both (a) and (b). In this embodiment, the displayed visual representation of the path extends between at least two of the plurality of rows **510** and between at least two of the plurality of columns **512**. In this embodiment, path **537** surrounds a region **525** (e.g., one of the regions **525c**). In this example embodiment, path **537** is a contiguous path. In this example embodiment, path **537** is a closed path. In this embodiment, the path display instructions of block **816** are further configured to cause the displayed visual representation of the path **537** to pass through at least some of the transducer graphical elements **502** associated with the transducers between which the regions of space associated with the selected between graphical elements **504** respectively reside. In some example embodiments (e.g., a visual or graphical representation (e.g., **600** in FIG. **6**) provided by a graphical interface (e.g., FIG. **6**)), the displayed visual representation of the path **537** includes a path segment that proceeds diagonally between a first node located at a first junction of a first one of the plurality of columns (e.g., columns **612**) and a first one of the plurality of rows (e.g., rows **610**) and a second node located at a second junction of a second one of the plurality of columns (e.g., columns **612**) and a second one of the plurality of rows (e.g., rows **610**), the first junction being different than the second junction. In this embodiment the path-display instructions of block **816** include instructions configured to cause the displayed graphical representation to change, during the time interval, a visual characteristic of the selected between graphical element **504** at least as part of forming the displayed visual representation of the path **537** (e.g., via elongated portion **530** in this embodiment). In this example embodiment, the path-display instructions of block **816** include instructions configured to cause the displayed graphical representation to change, during the time interval, a visual characteristic of at least some of the transducer graphical elements **502** associated with the transducers in the pairs of the transducers between which the regions of space associated with the selected between graphical ele-

ments 504 respectively reside. In some embodiments, the path 537 represents an ablation path or proposed or intended ablation path.

Block 810 of method 800 (which could represent a particular subset of implementations of block 712 in FIG. 7A in some embodiments) includes activation instructions (e.g., instructions provided in a program) configured to, in response to receiving the ablation request from the input-output device system, cause, via the input-output device system, energy from an energy source device system (e.g., energy source device system 340) to be delivered to each of the ablation-ready transducers of the at least some of the at least some of transducers in which ablation was requested by as per block 806, the activation instructions configured to cause the energy delivery to occur during the time interval. In this example embodiment, a selection of the control button 538 identified as "Ablate" in response to a user action via the input-output device system can cause execution of the activation instructions. In this example embodiment, the activation instructions of block 810 of method 800 include instructions (e.g., instructions provided in a program) configured to, in response to receiving the independent selections of between graphical elements 504 in accordance with selection instructions included in block 808, cause activation, via the input-output device system, of each of the pairs of the transducers between which the respective regions of space associated with the selected between graphical elements 504 respectively reside, the activation instructions configured to cause the activation to occur during the time interval. In this embodiment, the activation instructions include instructions configured to, in response to receiving the independent selections of the between graphical elements 504 cause energy from the energy source device system (e.g., energy source device system 340) to deliver energy to each of the pairs of the transducers between which the regions of space associated with the selected between graphical elements 504 respectively reside, the activation instructions configured to cause the energy delivery to occur during the time interval. In this example embodiment, the energy is tissue-ablation energy and the path 537 is representative of an ablation path. In some embodiments, the activation instructions include instructions configured to, in response to receiving the independent selections of the between graphical elements 504 cause monopolar activation of the transducers in each of the pairs of the transducers between which the regions of space associated with the selected between graphical elements 504 respectively reside, the activation instructions configured to cause the monopolar activation to occur during the time interval. In some embodiments, the activation instructions include instructions configured to, in response to receiving the independent selections of the between graphical elements 504 cause bipolar activation between the respective transducers in each of the pairs of the transducers between which the regions of space associated with the selected between graphical elements 504 respectively reside, the activation instructions configured to cause the bipolar activation to occur during the time interval. In this regard, the energy may be delivered in a manner that (a) a portion of the energy delivered to a first transducer of each pair of the transducers is transmitted by the first transducer, (b) a portion of the energy delivered to a second transducer of each pair of the transducers is transmitted by the second transducer, or both (a) and (b). In this regard, an indifferent electrode may be arranged to receive a portion of the energy delivered to at least one of the transducers of each of the pairs of the transducers between which the regions of space associated with the selected between graphical elements 504 respectively reside.

In some embodiments, selection of various graphical elements (e.g., graphical elements 501, 601) is not required to provide a visual representation of an ablation path (e.g., path 537). For example, FIG. 9 is a block diagram showing a method 900 including instructions (e.g., instructions provided in a program) for displaying a visual representation of an ablation path. Reference to the instructions provided by at least some of the blocks associated with method 700 is made for comparison purposes. Reference to various ones of FIG. 5 including transducer graphical elements 502 and between graphical elements 504 continues to be made for convenience of discussion. In some embodiments, method 900 may include a subset of the associated blocks or additional blocks than those shown in the FIG. 9. In some embodiments, method 900 may include a different sequence between various ones of the associated blocks than those shown in FIG. 9.

In a manner similar to block 702, block 902 of method 900 includes instructions (e.g., graphical representation instructions or graphical interface instructions included in a program) configured to cause an input-output device system (e.g., input-output device system 120 or 320) to display a graphical representation of at least a portion of a transducer-based device (e.g., transducer-based devices 200, 300, or 400). FIG. 5A illustrates a graphical interface provided by the input-output device system according to one example embodiment provided in accordance with block 902. The graphical interface of FIG. 5A includes a graphical representation 500 that includes a plurality of transducer graphical elements 502 and a plurality of between graphical elements 504, each characterized as per above. In a manner similar to block 704, block 904 of method 900 includes instructions (e.g., input instructions included in a program) that cause the data processing device system (e.g., data processing device systems 110 or 310) to receive transducer data from at least some of the transducers via the input-output device system.

In a manner similar to block 706, block 906 of method 900 includes instructions (e.g., identification instructions included in a program) that are configured to identify a region of the graphical representation that corresponds to at least a portion of one or more anatomical features based at least on the transducer data. In this example embodiment, a plurality of identified regions 525 is shown in the three-dimensional graphical representation provided by the graphical representation 500 of FIG. 5C and the two-dimensional graphical representation provided by the graphical representation 500 of FIG. 5D, each of the identified regions corresponding to a particular anatomical feature as previously discussed (e.g., ports related to various pulmonary veins, left lateral appendage and mitral valve).

Block 908 of method 900 includes selection instructions (e.g., instructions provided in a program) configured to cause the data processing device system (e.g., data processing device systems 110 or 310) to receive a selection from the input-output device system of at least one of the identified regions 525. Block 910 of method 900 includes path-display instructions (e.g., instructions provided in a program) configured to, in response to receiving the selection of the at least one of the identified regions, causes the displayed graphical representation to include a displayed visual representation of an ablation path configured for the anatomical feature.

Referring to FIG. 5D, a region 525 (e.g., region 525c) corresponding to a pulmonary vein of the left pulmonary vein group has been selected via the input-output device system. Again, various input-output device system components including a touch screen, keyboard or computer mouse may be employed to make the selection by way of non-limiting example. A path 537 defining an ablation path around the

selected region 525c is automatically generated in response to the selection of region 525c in accordance with the path display instructions of block 910.

Unlike the embodiment of FIG. 8, where an ablation path is defined by a user, the ablation path associated with the embodiment of FIG. 9 is defined by the data-processing device system. This can be accomplished in various ways. In this example embodiment, transducer data from the transducer-based device is used to help define each of the particular regions 525 as well as additional regions other than the regions 525 that can accommodate an ablation path configured for the anatomical feature corresponding to a selected region. In this example embodiment, the visual representation of the ablation path (e.g., represented by path 537) passes at least proximate to each of at least some of the transducer graphical elements 502 associated with the transducers associated with the particular ones of the additional regions positioned at least proximate region 525c. In some example embodiments, the visual representation of the ablation path passes at least proximate to each of at least some of the between graphical elements 504 (e.g., through the between graphical elements 504 in this embodiment) associated with pairs of the transducers associated with the particular ones of the additional regions positioned at least proximate region 525c. In some example embodiments, at least some of the transducers are deemed anatomical feature-specific transducers (e.g., transducers associated with a particular one of the anatomical features) based at least on the transducer data while others of the transducers are deemed not-anatomical feature-specific transducers (e.g., transducers not associated with a particular one of the anatomical features) based at least on the transducer data. In various example embodiments, method 900 includes instructions (not shown) (e.g., instructions provided in a program) configured to cause the data processing device system to determine the ablation path based at least on a determination of a proximity of various ones of the not-anatomical feature-specific transducers to various ones of the anatomical feature-specific features associated with an anatomical feature corresponding selected region 525. In some of these various example embodiments, the path-display instructions of block 910 includes instructions configured to, in response to receiving the selection of the at least one of the identified regions, cause the displayed graphical representation to include the displayed visual representation of an ablation path configured for the anatomical feature based at least on (a) an identification of the transducer graphical elements 502 associated with the various ones of the not-anatomical feature-specific transducers, (b) an identification of the between graphical elements 504 associated with pairs of the various ones of the not-anatomical feature-specific transducers, or both (a) and (b).

In this example embodiment, the path-display instructions are configured to, in response to receiving the selection of the identified region 525c, cause the displayed visual representation of the ablation path to surround the identified region 525c. In this example embodiment, the path-display instructions are configured to, in response to receiving the selection of the identified region 525c, cause the displayed visual representation of the ablation path to continuously surround the identified region 525c. In some example embodiments, the respective ablation paths associated with different ones of at least two selected ones of the identified regions 525 may have different configurations (e.g., shape, continuity). In some example embodiments, the transducer data includes data associated with an electrical characteristic (e.g., impedance) of tissue within a bodily cavity in which the transducer based-device or a portion thereof is receivable or positionable. In

some example embodiments, the transducer data includes data associated with a flow characteristic of fluid within a bodily cavity in which the transducer-based device or a portion thereof is receivable or positionable.

In this example embodiment, block 912 of method 900 includes instructions (e.g., instructions provided in a program) configured to, in response to receiving the selection of the identified region 525, cause the input-output device system to vary a visual characteristic of each of at least some of the graphical elements 501. In this example embodiment, a visual characteristic of each of at least some of the transducer graphical elements 502 and each of at least some of the between graphical elements 504 is changed.

In this example embodiment, block 914 of method 900 includes path-acceptance instructions (e.g., instructions provided in a program) configured to cause the data processing device system to receive an acceptance of the visual representation of the ablation path based at least on a user response via the input-output device system.

In this example embodiment, block 916 of method 900 includes activation instructions (e.g., instructions provided in a program) configured to, in response to receiving the acceptance, cause, via the input-output device system, energy from an energy source device system (e.g., energy source device system 340) to be delivered to each of the transducers associated with the at least some of the plurality of transducer graphical elements 502, the energy sufficient for ablating tissue. Ablation can include monopolar ablation, or bipolar ablation or combinations thereof.

FIG. 10 is an exploded view of the blocks 806 and 810 of a version of method 800 according to some example embodiments. In some embodiments, the ablation request instructions of block 806 include instructions (e.g., reception instructions provided in a program) as per block 807 configured to receive a selection from the input-output device system of a group of transducer sets, each of the sets of the group of the transducer sets including at least one of the transducers of the transducer-based device (e.g., transducer-based devices 200, 300, or 400). In these embodiments, each of the transducer sets is selected according to a first sequence. In some embodiments, at least part of the selection according to block 807 occurs by a selection of graphical elements, such that the instructions of block 808 are configured to cause the data processing device system (e.g., again exemplified by data processing device systems 110 or 310) to receive, via the input-output device system (e.g., again exemplified by input-output device systems 120, 320) a selection of at least some of the graphical elements 501 associated with some or all of the plurality of transducer sets discussed above with respect to block 807. In some example embodiments, each of the transducer graphical elements 502 associated with the plurality of transducer sets is selected according to the first sequence. For example, as shown in FIG. 5F, the transducer graphical elements 502 associated with path 537 may be selected in a sequential fashion in the following order (e.g., each selected transducer graphical element 502 indicated by the corresponding identification labels 513: "R:6", "Q:6", "P:6", "P:7", "O:7", "O:8", "O:9", "P:9", "P:10", "Q:10", "R:10", "R:9", "S:9", "S:8", "S:7", and "R:7" to select the plurality of transducer sets according to the first sequence. In such embodiments, each transducer set may be considered to have a single transducer. Also, as shown in FIG. 5F, the between graphical elements 504 associated with path 537 may be selected in a sequential fashion in the following order (e.g., each selected between graphical element 504 herein identified by the corresponding pair of identification labels 513 associated with the transducer graphical elements 502 in

which the selected between graphical element **504** is positioned between): “R:6-Q:6”, “Q:6-P:6”, “P:6-P:7”, “P:7-O:7”, “O:7-O:8”, “O:8-O:9”, “O:9-P:9”, “P:9-P:10”, “P:10-Q:10”, “Q:10-R:10”, “R:10-R:9”, “R:9-S:9”, “S:9-S:8”, “S:8-S:7”, “S:7-R:7” and “R:7-R:6” to select the plurality of transducer sets according to the first sequence. In such embodiments, each transducer set may be considered to have at least two transducers. In this embodiment, each of the selected between graphical elements **504** is associated with a region of space between a pair of transducers that include the respective first and second transducers which make up a respective set of group of transducer sets. It is noted that the first sequence can take other forms in other embodiments. For example, the transducer sets may be selected randomly or pseudo-randomly according to the first sequence. In other embodiments, the first sequence may not require successively adjacent transducers in a distribution of the transducers to be selected as described above.

In various embodiments, each of the transducer sets in the first sequence form part of a group of the transducer sets. In various embodiments, various transducer sets in a group of transducer sets are selected according to a first sequence (e.g., the first sequence described above with regard to block **807**) with at least two of the transducer sets in the group sequentially selected. In accordance with the discussion above, in at least some of these various embodiments, each of at least some of the selected transducer sets in the group includes at least one transducer different than each of the other transducer sets in the group. In at least some of these various embodiments, each of at least some of the transducer sets in the group includes at least two transducers. In at least some of these various embodiments, each of at least some of the transducer sets in the group includes a respective pair of adjacent ones of the transducers in a distribution of the transducers. The respective pair of adjacent ones of the transducers of each of the at least some of the transducer sets in the group may have a same transducer as the respective pair of adjacent ones of the transducers of another of the at least some of the of the transducer sets in the group. In some of these various embodiments, at least a first transducer set in the group has a same transducer as a second transducer set in the group. In at least some of these various embodiments, two or more of the transducers in a given one of the transducer sets may be selected concurrently (e.g., a pair of transducers selected by a selection of a between graphical element **504, 604** as described above). In at least some of these various embodiments, two or more of the transducer sets in the group may also be selected concurrently in the first sequence. In at least some of these various embodiments, an additional transducer set may be selected concurrently with one of the at least two of the transducer sets sequentially selected according to the first sequence. Transducer sets in the group that include different numbers of transducers or different transducers may be selected according to the first sequence. For example, the first sequence may indicate at least (a) a selection (e.g., by a selection of a transducer graphical element **502, 602**) of a first transducer in a first transducer set in the group followed by a selection (e.g., by a selection of a between graphical element **504, 604**) of a pair of second and third transducers in a second transducer set in the group, (b) a selection (e.g., by a selection of a between graphical element **504, 604**) of a pair of fourth and fifth transducers in a third transducer set in the group followed by a selection (e.g., by a selection of a transducer graphical element **502, 602**) of a sixth transducer in a fourth transducer set in the group, or both (a) and (b).

In some embodiments, the activation instructions of block **810** of method **800** includes activation instructions as per

block **811** (e.g., instructions provided in a program) configured to cause sequential activation, initiated during or after completion of a generation of a second sequence of transducer sets (discussed below), of the transducer sets in the second sequence of transducer sets. The activation of the transducer sets in the second sequence occurs according to the second sequence, and the activation instructions are configured to cause activation of at least one transducer in each of the sequentially activated sets. In one particular embodiment, the activation of instructions of block **811** are configured to cause activation of the transducer sets of a group of transducer sets according to a second sequence different than the first sequence in which the transducer sets of the group of transducers sets were selected.

The second sequence may be determined in various manners. For example, in some embodiments, method **800** may include a block **809** (e.g., shown in FIG. **10**, not shown in FIG. **8**) that includes generation instructions (e.g., instructions provided in a program) configured to, in response to receiving at least part of the first sequence, cause a generation (e.g., via a data processing device system such as data processing device systems **110** or **310**) of the second sequence of transducer sets based at least on an analysis of the transducer sets in a group of which the transducer sets in the first sequence form at least part.

We now turn to embodiments that vary visual characteristics of graphical elements during transducer activation processes. For example, the activation instructions as per block **811** in method **800** in FIG. **10**, can include activation instructions configured to, in response to receiving at least part of a selection of various between graphical elements **504** associated with each of a plurality of transducer sets selected according to a first sequence, cause, via the input-output device system, energy from an energy source device system (e.g., energy source device system **340**) to be delivered to each of the transducer sets according to a second sequence different than the first sequence. In some embodiments, during this energy delivery process, visual characteristics of the selected between graphical elements **504** can be varied to illustrate to a user a status of the energy delivery process. It should be noted, however, that the variances of visual characteristics described herein need not apply only to the method **800** or to the selection of between graphical elements **504**, but can also apply to any activation process and to any graphical element according to the various embodiments described herein. The method **800** and between graphical elements **504** are only used for illustration purposes.

In this regard, FIGS. **5G** and **5H**, show example sequential variances in visual characteristics of respective ones of the between graphical elements **504** associated with at least some of the transducers sets as they are activated according to the second sequence. Changes in the visual characteristics are highlighted in accordance with a KEY provided in each of FIGS. **5G, 5H** and **5I**. It is understood that the KEY is provided for illustrative purposes and does not form part of the graphical representation in this example embodiment. As discussed above, variances in visual characteristics may include changing a color, opacity, hue, intensity, shading, pattern, shape or the addition or removal of any displayed information.

FIG. **5G** is associated with a condition in which energy is being delivered (e.g., according to the second sequence) to the respective transducer set associated with the first between graphical element **504a** (e.g., previously identified as “R:6-Q:6” and to the respective transducer set associated with another between graphical element **504** (e.g., previously identified as “P:10-Q:10”) while energy is not delivered to the

respective transducer sets associated with the remaining ones of the selected between graphical elements 504. It is noted that the energy delivered to the transducer set associated with the between graphical element 504 previously identified as “P:10-Q:10” is not delivered according to the sequence it was selected with respect to the other of the transducer sets. It is noted that the respective electrograms 535 associated with the respective transducers of at least some of the transducer sets to which energy is delivered (e.g., the transducer set associated with the between graphical element 504 previously identified as “P:10-Q:10”) are repositioned in the graphical representation for enhanced viewing during the energy delivery (e.g., as best compared between FIGS. 5F and 5G).

FIG. 5H is associated with a condition in which the energy delivery has been completed to respective transducer sets associated with each of the between graphical elements 504 previously identified as “R:6-Q:6” and “P:10-Q:10”. FIG. 5H is associated with a condition in which energy is being delivered to the respective transducer sets associated with the between graphical elements 504 previously identified as “R:9-S:9” and “S:7-R:7” while energy is not delivered to the other respective transducer sets that have not yet received energy or the other respective transducer sets in which the energy delivery has been completed. Again, it is noted that the energy delivered to the transducer sets associated with the between graphical elements 504 previously identified as “R:9-S:9” and “S:7-R:7” is not delivered according to the first sequence in which these transducer sets were selected with respect to the others of the group of transducer sets. In this example embodiment, the energy delivery process according to the remainder of the second sequence continues, until energy has been delivered to all of the remaining selected transducer sets as exemplified in FIG. 5I. It is noted that for brevity of illustration, energy delivery to every one of the selected remaining transducer sets in accordance with the remainder of the second sequence has not been shown.

In this example embodiment, the activation instructions of blocks 810, 811 cause the transmission of energy-delivery instructions (not shown) to cause energy from the energy source device system to be delivered to each of the respective first transducer and second transducer of the corresponding transducer set associated with each of the selected between graphical elements 504. FIG. 8 includes a block 818 that includes determination instructions (e.g., instructions provided by a program) configured to determine an energy-delivery status associated with at least one of the respective first transducer and the respective second transducer associated with each of the selected between graphical elements 504, the energy delivery status indicating a status of the energy delivery by the energy source device system to the at least one of the respective first transducer and the respective second transducer. In some embodiments, the energy delivery status includes a status of a portion of the energy delivered by the energy source device system to the at least one of the respective first transducer and the respective second transducer, the portion of the energy transmitted by the at least one of the respective first transducer and the respective second transducer. FIG. 8 includes a block 820 that includes energy delivery indication instructions configured to cause the input-output device system to change a displayed visual characteristic of a selected between graphical element 504 based at least on the determined energy-status of the at least one of the respective first transducer and the respective second transducer. For example, referring to FIG. 5G, the energy delivery status associated with the at least one of the respective first and the respective second transducers associated with the selected between graphical element 504a previously identified

as “R:6-Q:6” includes a during-energy delivery status associated with a state during the energy delivery by the energy source device system to the at least one of the first transducer and the second transducer associated with the selected between graphical element 504a previously identified as “R:6-Q:6”. The energy delivery status associated with the at least one of the respective first and second transducers associated with the selected between graphical element 504 previously identified as “S:7-R:7” includes a pre-energy-delivery status associated with a state before a start of energy delivery by the energy source device system to the at least one of the first transducer and the second transducer associated with the selected between graphical element 504 previously identified as “S:7-R:7”. As shown in FIG. 5G, a first displayed visual characteristic of the between graphical elements 504 is associated with the pre-energy-delivery status (e.g., the selected between graphical element 504 previously identified as “S:7-R:7”) and a second displayed visual characteristic of the between graphical elements 504 is associated with the during-energy-delivery status (e.g., the selected between graphical element 504 previously identified as “R:6-Q:6”), the second displayed visual characteristic being different than the first displayed visual characteristic. Differences in the displayed visual characteristics may include different colors, opacities, hues, intensity, shading, patterns, shapes or any suitable addition or removal of any displayed information sufficient for characterizing the difference. In some embodiments, the first displayed visual characteristic of a between graphical element 504 associated with the pre-energy delivery status is different than a visual characteristic of the between graphical element 504 resulting upon a selection of the between graphical element 504 (e.g., as per block 812). In this embodiment, the first displayed visual characteristic of a between graphical element 504 associated with the pre-energy delivery status is the same as a visual characteristic of the between graphical element 504 resulting upon a selection of the between graphical element 504. It is noted that in this example embodiment that the between graphical element 504a previously identified as “R:6-Q:6” included the first displayed visual characteristic prior to energy delivery to the corresponding ones of the transducers.

In FIG. 5H, the energy delivery status associated with the at least one of the first transducer and the second transducer associated with the between graphical element 504a previously identified as “R:6-Q:6” includes a post-energy-delivery status associated with a state after a completion of the energy delivery from the energy source device system to the at least one of the first transducer and the second transducer associated with the between graphical element 504a previously identified as “R:6-Q:6”. In FIG. 5H, a pre-energy-delivery status is associated with at least some of the between graphical elements (e.g., the between graphical element 504 previously identified as “P:7-O:7”) and a during-energy-delivery status is associated with at least some of the between graphical elements (e.g., the between graphical element 504 previously identified as “S:7-R:7”). In this example embodiment, a third displayed visual characteristic of the between graphical elements 504 associated with the post-energy delivery-state (e.g., the between graphical element 504a previously identified as “R:6-Q:6”) is different than at least one (e.g., both in this example embodiment) of the first displayed visual characteristic of the between graphical elements 504 associated with the pre-energy delivery-state (e.g., the between graphical element 504 previously identified as “P:7-O:7”) and the second displayed visual characteristic of the between graphical elements 504 associated with the during-energy delivery-state (e.g., the between graphical element 504 pre-

viously identified as “S:7-R:7”). In FIG. 5I all of the selected between graphical elements 504 are shown with the third displayed visual characteristic, indicating that completion of the energy delivery to their respective transducer sets has occurred. In this example embodiment, the displayed visual characteristics of at least some of the respective transducer graphical elements 502 associated with the respective first and the second transducers associated with each selected between graphical elements undergo changes in accordance with changes in the energy delivery state. The displayed visual characteristics associated with the various energy-delivery states are depicted in accordance with the KEY provided in each of FIGS. 5G, 5H and 5I.

While some of the embodiments disclosed above are described with examples of cardiac mapping, the same or similar embodiments may be used for mapping other bodily organs, for example gastric mapping, bladder mapping, arterial mapping and mapping of any lumen or cavity into which the devices of the present invention may be introduced.

While some of the embodiments disclosed above are described with examples of cardiac ablation, the same or similar embodiments may be used for ablating other bodily organs or any lumen or cavity into which the devices of the present invention may be introduced.

Subsets or combinations of various embodiments described above can provide further embodiments.

These and other changes can be made to the invention in light of the above-detailed description. In general, in the following claims, the terms used should not be construed to limit the invention to the specific embodiments disclosed in the specification and the claims, but should be construed to include other transducer-based device systems including all medical treatment device systems and all medical diagnostic device systems in accordance with the claims. Accordingly, the invention is not limited by the disclosure, but instead its scope is to be determined entirely by the following claims.

What is claimed is:

1. A transducer-activation system comprising:

a data processing device system;

an input-output device system communicatively connected to the data processing device system; and

a memory device system communicatively connected to the data processing device system and storing a program executable by the data processing device system, the program comprising:

graphical interface instructions configured to cause the input-output device system to display a graphical interface including a graphical representation of at least some of a plurality of graphical elements, each of the plurality of graphical elements respectively associated with a respective one of a plurality of transducer sets, each respective transducer set including at least one of a plurality of transducers included as part of a transducer-based device, and each respective transducer set having at least one different transducer than another of the other transducer sets;

input instructions configured to cause reception of transducer data via the input-output device system, the transducer data indicating data acquired by the plurality of transducers;

identification instructions configured to cause identification of ablation-ready transducers of the plurality of transducers as transducers that are adjacent a region of space deemed, based at least on an analysis of the transducer data, acceptable for ablation, and not-ablation-ready transducers of the plurality of transducers as transducers that are adjacent a region of space deemed, based

at least on the analysis of the transducer data, not acceptable for ablation, wherein the graphical interface includes a first set of visual characteristics associated with the graphical elements that are associated with each of the transducers sets comprising the ablation-ready transducers, and includes a second set of visual characteristics associated with the graphical elements that are associated with the transducer sets comprising the not-ablation-ready transducers, the first set of visual characteristics being different than the second set of visual characteristics;

ablation request instructions configured to cause reception of an ablation request from the input-output device system, the ablation request configured to request ablation by at least some of the plurality of transducers;

activation instructions configured to, in response to receiving the ablation request from the input-output device system, cause energy from an energy source device system to be delivered to each of the plurality of ablation-ready transducers in the at least some of the plurality of transducers; and

non-activation instructions configured to cause prevention of delivery of energy from the energy source device system to each of the plurality of not-ablation-ready transducers.

2. The transducer-activation system of claim 1 wherein the ablation request instructions are configured to cause reception of a selection from the input-output device system of the graphical elements associated with the respective transducer sets comprising the at least some of the plurality of transducers.

3. The transducer-activation system of claim 1 wherein each transducer set comprises a single transducer of the plurality of transducers.

4. The transducer-activation system of claim 1 wherein each transducer set comprises at least a pair of the plurality of transducers.

5. The transducer-activation system of claim 4 wherein the plurality of transducers are arranged in a distribution, the plurality of transducers positionable within in a bodily cavity, and wherein each pair of the plurality of transducers is a pair of adjacent transducers in the distribution.

6. The transducer-activation system of claim 5 wherein each of the transducers in the distribution is spaced apart from each of the other transducers in the distribution.

7. The transducer-activation system of claim 4 wherein the first set of visual characteristics is associated only with the graphical elements that are associated with the transducer sets each consisting of transducers identified by the identification instructions as only being ablation-ready transducers.

8. The transducer-activation system of claim 7 wherein the second set of visual characteristics is associated only with the graphical elements that are associated with the transducer sets each having at least one transducer identified by the identification instructions as being a not-ablation-ready transducer.

9. The transducer-activation system of claim 4 wherein the graphical interface instructions are further configured to cause the input-output device system to display only the graphical elements associated with transducer sets consisting of transducers identified by the identification instructions as only being ablation-ready transducers.

10. The transducer-activation system of claim 1 wherein the graphical interface instructions are further configured to cause the input-output device system to display only the graphical elements associated with transducer sets consisting of transducers identified by the identification instructions as only being ablation-ready transducers.

11. The transducer-activation system of claim 1 wherein the at least some of the plurality of transducers is an ablation-requested transducer set, and wherein the program further comprises:

determination instructions configured to cause determination of whether the ablation-requested transducer set comprises a not-ablation-ready transducer; and ablation denial instructions configured to, if it is determined according to the determination instructions that the ablation-requested transducer set comprises the not-ablation-ready transducer, cause denial of the ablation request, at least with respect to the not-ablation-ready transducer in the ablation-requested transducer set.

12. The transducer-activation system of claim 1 wherein the at least some of the plurality of transducers is an ablation-requested transducer set, and wherein the program further comprises:

determination instructions configured to cause determination of whether the ablation-requested transducer set comprises a not-ablation-ready transducer; and ablation denial instructions configured to cause denial of the ablation request if it is determined according to the determination instructions that the ablation-requested transducer set comprises the not-ablation-ready transducer.

13. The transducer-activation system of claim 1 wherein the input-output device system comprises the transducer-based device.

14. The transducer-activation system of claim 1 wherein the plurality of transducers are arranged in a distribution, the plurality of transducers positionable within a bodily cavity and wherein the identification instructions comprise instructions configured to cause a requirement that, in order for a region of space to be deemed acceptable for ablation, the region of space be determined, based at least on the analysis of the transducer data, to be associated with a tissue in the bodily cavity that is acceptable for ablation, and wherein the identification instructions further comprise instructions configured to cause a requirement that, in order for a region of space to be deemed not acceptable for ablation, the region of space be determined, based at least on the analysis of the transducer data, to be associated with a tissue in the bodily cavity that is not acceptable for ablation.

15. The transducer-activation system of claim 14 wherein the bodily cavity is an intra-cardiac cavity and the tissue in the bodily cavity that is not acceptable for ablation is blood.

16. The transducer-activation system of claim 1 wherein the plurality of transducers are arranged in a distribution, the plurality of transducers positionable within a bodily cavity and wherein the identification instructions comprise instructions configured to cause a requirement that, in order for a region of space to be deemed acceptable for ablation, the region of space be determined, based at least on the analysis of the transducer data, to be associated with an anatomical feature of the bodily cavity that is acceptable for ablation, and wherein the identification instructions further comprise instructions configured to cause a requirement that, in order for a region of space to be deemed not acceptable for ablation, the region of space be determined, based at least on the analysis of the transducer data, to be associated with an anatomical feature of the bodily cavity that is not acceptable for ablation.

17. The transducer-activation system of claim 16 wherein the plurality of transducers are arranged in a distribution, the plurality of transducers positionable within a bodily cavity comprising a tissue wall surface interrupted by one or more ports in fluid communication with the bodily cavity, and

wherein the identification instructions comprise instructions configured to cause a requirement that, in order for a region of space to be deemed not acceptable for ablation, the region of space be determined, based at least on the analysis of the transducer data, to overlie at least part of a port of the one or more ports.

18. The transducer-activation system of claim 1 wherein each respective transducer set has at least one different transducer than each of the other transducer sets.

19. A transducer-selection system comprising:

a data processing device system;

an input-output device system communicatively connected to the data processing device system; and

a memory device system communicatively connected to the data processing device system and storing a program executable by the data processing device system, the program comprising:

display instructions configured to cause the input-output device system to display a graphical representation of at least a portion of a transducer-based device, the transducer-based device including a structure and a plurality of transducers located on the structure, the plurality of transducers arranged in a distribution positionable in a bodily cavity, and the graphical representation including a plurality of graphical element sets, each graphical element set including one or more graphical elements and each graphical element set associated with a respective one of a plurality of pairs of adjacent ones of the transducers in the distribution, no two of the pairs of adjacent ones of the transducers in the distribution having an identical pair of adjacent ones of the transducers in the distribution; and

identification instructions configured to cause identification of which of the respective transducers of each of the pairs of adjacent ones of the transducers in the distribution are and which are not acceptable for concurrent selection,

wherein the display instructions are configured to cause the input-output device system to display each of the graphical element sets associated with each of the pairs of adjacent ones of the transducers in the distribution whose respective transducers have been identified, according to the identification instructions, to be acceptable for concurrent selection with a respective set of visual characteristics that distinguishes each of the graphical element sets associated with each of the pairs of adjacent ones of the transducers in the distribution whose respective transducers have been identified, according to the identification instructions, to be acceptable for concurrent selection from each of the graphical element sets associated with each of the pairs of adjacent ones of the transducers in the distribution whose respective transducers have been identified, according to the identification instructions, to be not acceptable for concurrent selection.

20. The transducer-selection system of claim 19 wherein the program further comprises first selection instructions configured to cause selection of at least one graphical element in a first set of the plurality of graphical element sets that is associated with a first pair of the plurality of pairs of adjacent ones of the transducers in the distribution whose respective transducers have been identified, according to the identification instructions, to be acceptable for concurrent selection, and to cause concurrent selection, in response to the selection of the at least one graphical element in the first set of the plurality of graphical element sets, of the respective transduc-

ers of the first pair of the plurality of pairs of adjacent ones of the transducers in the distribution.

21. The transducer-selection system of claim 20 wherein the selection of the at least one graphical element in the first set of the plurality of graphical element sets includes a selection of a particular graphical element in the first set of the plurality of graphical element sets made in response to a user instruction to select a user-selected graphical element in the first set of the plurality of graphical element sets.

22. The transducer-selection system of claim 20 wherein the program further comprises activation instructions configured to, in response to the concurrent selection, cause concurrent activation, via the input-output device system, of each of the respective transducers of the first pair of the plurality of pairs of adjacent ones of the transducers in the distribution.

23. The transducer-selection system of claim 21 wherein the activation instructions are further configured to, in response to the concurrent selection, cause monopolar activation, via the input-output device system, of each of the respective transducers of the first pair of the plurality of pairs of adjacent ones of the transducers in the distribution.

24. The transducer-selection system of claim 23 wherein the input-output device system comprises the transducer-based device and an energy source device system connected to each of the respective transducers of the first pair of the plurality of pairs of adjacent ones of the transducers in the distribution, and

wherein the activation instructions are further configured to cause energy from the energy source device system to be delivered, for the monopolar activation, to each of the respective transducers of the first pair of the plurality of pairs of adjacent ones of the transducers in the distribution, the energy sufficient to cause ablation of tissue in the bodily cavity.

25. The transducer-selection system of claim 24 wherein the energy is sufficient to cause an electrophysiological activity conduction block in the tissue between the respective transducers of the first pair of the plurality of pairs of adjacent ones of the transducers in the distribution.

26. The transducer-selection system of claim 20, wherein the input-output device system comprises the transducer-based device,

wherein the bodily cavity is an intra-cardiac cavity, wherein each respective transducer of the first pair of the plurality of pairs of adjacent ones of the transducers in the distribution is configured to detect electrophysiological activity in the intra-cardiac cavity at a location at least proximate the respective transducer of the first pair of the plurality of pairs of adjacent ones of the transducers in the distribution, and

wherein the program further comprises instructions configured to, in response to the concurrent selection, cause generation of a combined electrogram based at least on input received via the input-output device system from both of the respective transducers of the first pair of the plurality of pairs of adjacent ones of the transducers in the distribution.

27. The transducer-selection system of claim 20 wherein the program further comprises activation instructions configured to, in response to the concurrent selection, cause bipolar activation, via the input-output device system, between each of the respective transducers of the first pair of the plurality of pairs of adjacent ones of the transducers in the distribution.

28. The transducer-selection system of claim 20, wherein the input-output device system comprises the transducer-based device and an energy source device system connected to each of the respective transducers

of the first pair of the plurality of pairs of adjacent ones of the transducers in the distribution, and

wherein the program further comprises activation instructions configured to, in response to the concurrent selection, cause energy from the energy source device system to be delivered to each of the respective transducers of the first pair of the plurality of pairs of adjacent ones of the transducers in the distribution in a manner that, (a) a portion of the energy delivered to a first transducer of the first pair of the plurality of pairs of adjacent ones of the transducers in the distribution is transmitted by the first transducer to a second transducer of the first pair of the plurality of pairs of adjacent ones of the transducers in the distribution, (b) a portion of the energy delivered to the second transducer is transmitted by the second transducer to the first transducer, or both (a) and (b).

29. The transducer-selection system of claim 20 wherein the program further comprises second selection instructions configured to cause selection of at least one graphical element in a second set of the plurality of graphical element sets that is associated with a second pair of the plurality of pairs of adjacent ones of the transducers in the distribution whose respective transducers have been identified, according to the identification instructions, to be not acceptable for concurrent selection, and to cause non-concurrent selection, in response to the selection of the at least one graphical element in the second set of the plurality of graphical element sets, of the respective transducers of the second pair of the plurality of pairs of adjacent ones of the transducers in the distribution.

30. The transducer-selection system of claim 29 wherein the first and the second pairs of the plurality of pairs of adjacent ones of the transducers in the distribution share a same transducer in the distribution.

31. The transducer-selection system of claim 29, wherein the selection of the at least one graphical element in the first set of the plurality of graphical element sets is a selection, at one time, of each of the at least one graphical element in the first set of the plurality of graphical element sets, and

wherein the selection of the at least one graphical element in the second set of the plurality of graphical element sets is a selection, over a time interval, of at least two of the graphical elements in the second set of the plurality of graphical element sets.

32. The transducer-selection system of claim 29 wherein the second set of the plurality of graphical element sets has a different number of graphical elements than the first set of the plurality of graphical element sets.

33. The transducer-selection system of claim 29 wherein the program further comprises third selection instructions configured to, (a) in response to receiving a user instruction to select at least a first user-selected graphical element in the first graphical element set, cause the data processing device system to select at least a second graphical element in the first graphical element set, (b) in response to receiving a user instruction to select at least a first user-selected graphical element in the second graphical element set, cause the data processing device system to select at least a second graphical element in the second graphical element set, or both (a) and (b).

34. The transducer-selection system of claim 29 wherein the program further comprises second activation instructions configured to, in response to the non-concurrent selection, cause activation, via the input-output device system, of each of the respective transducers of the second pair of the plurality of pairs of adjacent ones of the transducers in the distribution, the second activation instructions configured to preclude

bipolar activation between each of the respective transducers of the second pair of the plurality of pairs of adjacent ones of the transducers in the distribution.

35. The transducer-selection system of claim 29 wherein the program further comprises second activation instructions 5 configured to, in response to the non-concurrent selection, cause non-concurrent activation, via the input-output device system, of each of the respective transducers of the second pair of the plurality of pairs of adjacent ones of the transducers in the distribution. 10

* * * * *

UNITED STATES PATENT AND TRADEMARK OFFICE
CERTIFICATE OF CORRECTION

PATENT NO. : 9,011,423 B2
APPLICATION NO. : 13/792670
DATED : April 21, 2015
INVENTOR(S) : Jeffery Charles Brewster et al.

Page 1 of 1

It is certified that error appears in the above-identified patent and that said Letters Patent is hereby corrected as shown below:

In the Claims,

Claim 5, at column 100, line 40, "within in a bodily cavity," should read as --within a bodily cavity,--.

Signed and Sealed this
Seventeenth Day of November, 2015

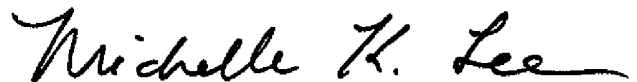

Michelle K. Lee
Director of the United States Patent and Trademark Office

专利名称(译)	用于选择，激活或选择和激活换能器的系统和方法		
公开(公告)号	US9011423	公开(公告)日	2015-04-21
申请号	US13/792670	申请日	2013-03-11
[标]申请(专利权)人(译)	卡尔蒂姆公司		
申请(专利权)人(译)	KARDIUM INC.		
当前申请(专利权)人(译)	KARDIUM INC.		
[标]发明人	BREWSTER JEFFERY CHARLES REINDERS DANIEL MARTIN WEINKAM DANIEL ROBERT		
发明人	BREWSTER, JEFFERY CHARLES REINDERS, DANIEL MARTIN WEINKAM, DANIEL ROBERT		
IPC分类号	A61B18/00 A61B18/12 A61B5/00 A61B5/01 A61B5/042 A61B5/053 A61B18/14 A61N1/362		
CPC分类号	A61B18/1233 A61B5/053 A61B5/6858 A61B5/743 A61B5/7435 A61B5/0422 A61B5/0538 A61B18/1206 A61B5/6869 A61B5/01 A61B18/1492 A61N1/362 A61B2018/00267 A61B2018/00357 A61B2018/00577 A61B2018/00797 A61B2018/00839 A61B2018/00875 A61B2018/00892 A61B34/25 A61B2017/00199 A61B2018/00351 A61B2018/00363 A61B2018/00642 A61B2018/00648 A61B2018/00654 A61B2018/00708 A61B2018/00863 A61B2018/00904 A61B2018/00988 A61B2018/124 A61B2034/254 A61B5/026 A61B5/042 A61B18/14 A61N1/37264 G06F3/0482 G06F3/04842		
优先权	61/723311 2012-11-06 US 61/670881 2012-07-12 US 61/649734 2012-05-21 US		
其他公开文献	US20130310827A1		
外部链接	Espacenet USPTO		

摘要(译)

基于换能器的系统可以被配置为显示基于换能器的设备的图形表示，该图形表示包括与基于换能器的设备的换能器相对应的图形元件，并且还包含分别与一组换能器相关联的图形元件和分别与基于换能器的装置的换能器之间的空间区域相关联。图形元素的选择和/或图形元素之间的选择可以激活与所选元素相关联的一组换能器。选择多个图形元素和/或在图形元素之间可以导致在图形表示中可视地显示相应的激活路径。图形元素的视觉特性和图形元素之间的视觉特性可以基于相应换能器的激活状态而改变。如果确定该组换能器中的换能器不能被激活，则可以拒绝对该组换能器的激活请求。

