



(19) **United States**

(12) **Patent Application Publication**  
**Bardy et al.**

(10) **Pub. No.: US 2019/0231213 A1**

(43) **Pub. Date: Aug. 1, 2019**

(54) **WEARABLE ELECTROCARDIOGRAPHY  
AND PHYSIOLOGY MONITORING  
ENSEMBLE**

**Publication Classification**

(71) Applicant: **Bardy Diagnostics, Inc.**, Seattle, WA  
(US)

(51) **Int. Cl.**  
*A61B 5/0408* (2006.01)  
*A61B 5/00* (2006.01)  
*A61B 5/0432* (2006.01)

(72) Inventors: **Gust H. Bardy**, Carnation, WA (US);  
**Mark Handfelt**, Kirkland, WA (US);  
**Jon Mikalson Bishay**, Lexington, KY  
(US); **Jason Felix**, Vashon Island, WA  
(US)

(52) **U.S. Cl.**  
CPC ..... *A61B 5/04085* (2013.01); *A61B 5/6833*  
(2013.01); *A61B 5/6823* (2013.01); *A61B*  
*5/6804* (2013.01); *A61B 5/0006* (2013.01);  
*A61B 2560/0412* (2013.01); *A61B 2562/222*  
(2013.01); *A61B 2562/227* (2013.01); *A61B*  
*2562/0209* (2013.01); *A61B 2562/164*  
(2013.01); *A61B 2560/0443* (2013.01); *A61B*  
*5/0432* (2013.01)

(21) Appl. No.: **16/378,458**

(22) Filed: **Apr. 8, 2019**

**Related U.S. Application Data**

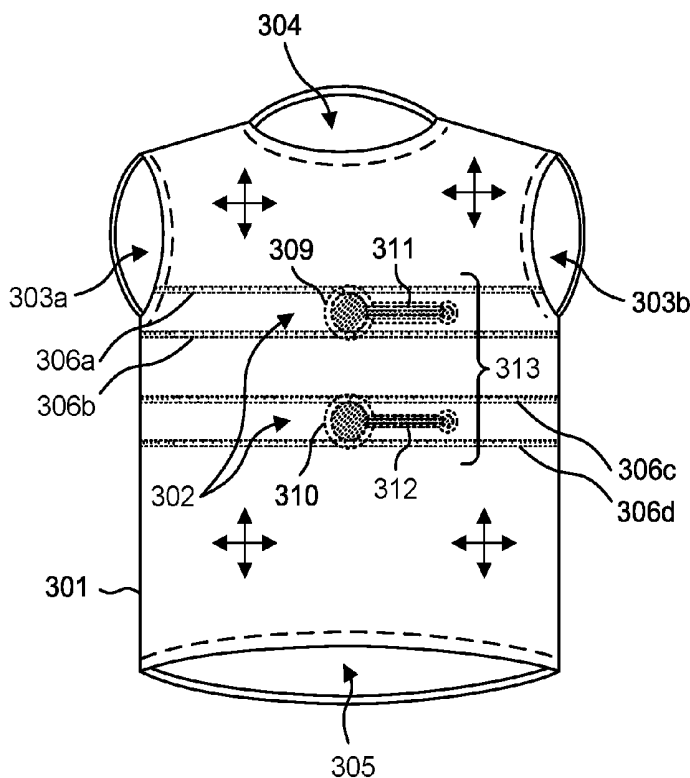
(63) Continuation of application No. 15/602,003, filed on  
May 22, 2017, now Pat. No. 10,251,575, which is a  
continuation of application No. 14/734,853, filed on  
Jun. 9, 2015, now Pat. No. 9,655,537, which is a  
continuation-in-part of application No. 14/463,585,  
filed on Aug. 19, 2014, now Pat. No. 9,717,432,  
which is a continuation-in-part of application No.  
14/080,717, filed on Nov. 14, 2013, now Pat. No.  
9,545,204.

(60) Provisional application No. 61/882,403, filed on Sep.  
25, 2013.

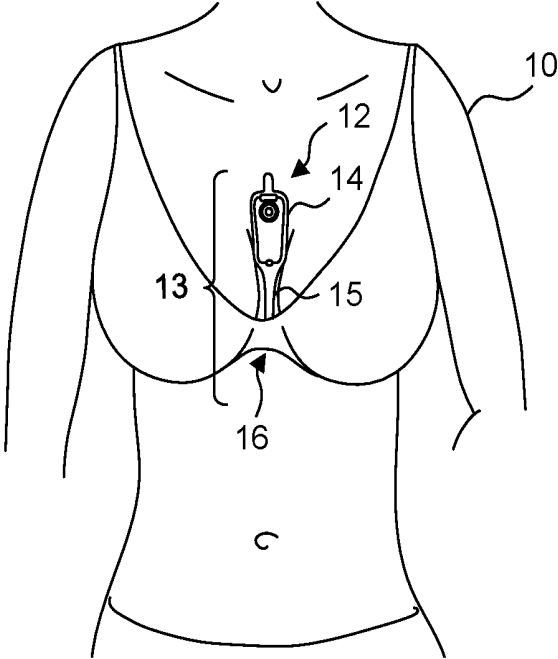
(57) **ABSTRACT**

A wearable electrocardiography monitoring ensemble is provided. A first receptacle is defined in a wearable garment by two horizontal bands placed across the wearable garment. A second receptacle is defined by two further horizontal bands positioned across the wearable garment under the first receptacle. A first electrode assembly is positioned within the first receptacle and includes a backing with an electrical connection having an electrode on one end of the electrical connection and terminated at the other end of the electrical connection to connect with a monitor recorder. A second electrode assembly is positioned within the second receptacle and includes a backing with an electrical connection having an electrode on one end of the electrical connection and terminated at the other end of the electrical connection to connect with a further monitor recorder, wherein the first and second electrodes are aligned longitudinally in the wearable garment.

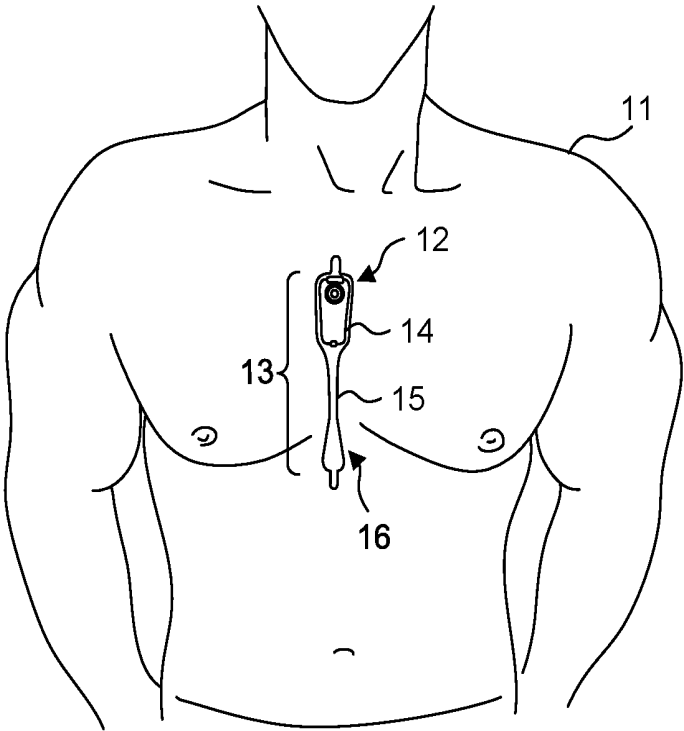
300



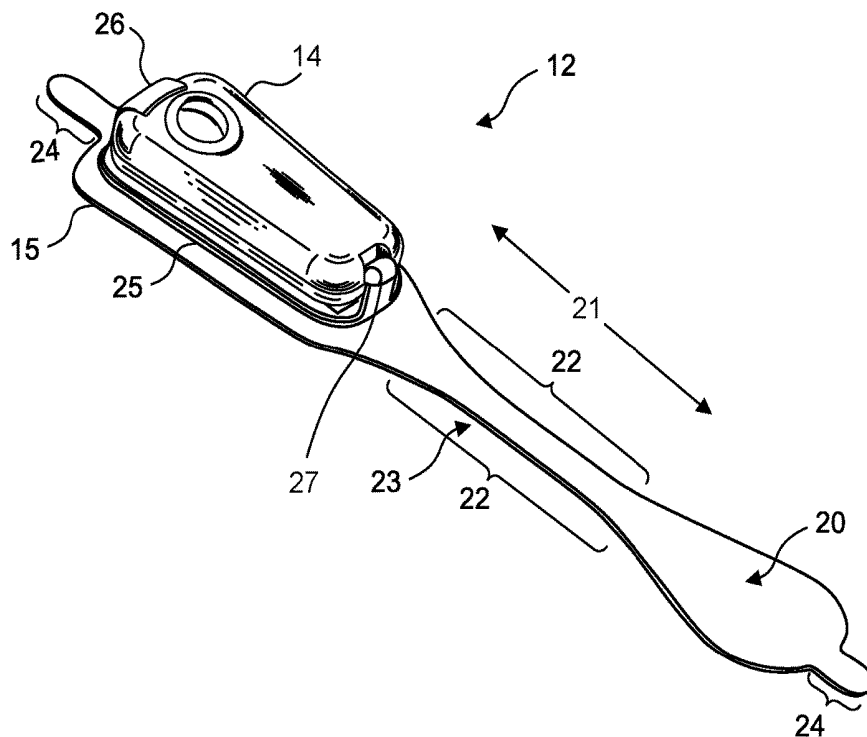
**Fig. 1.**



**Fig. 2.**



**Fig. 3.**



**Fig. 4.**

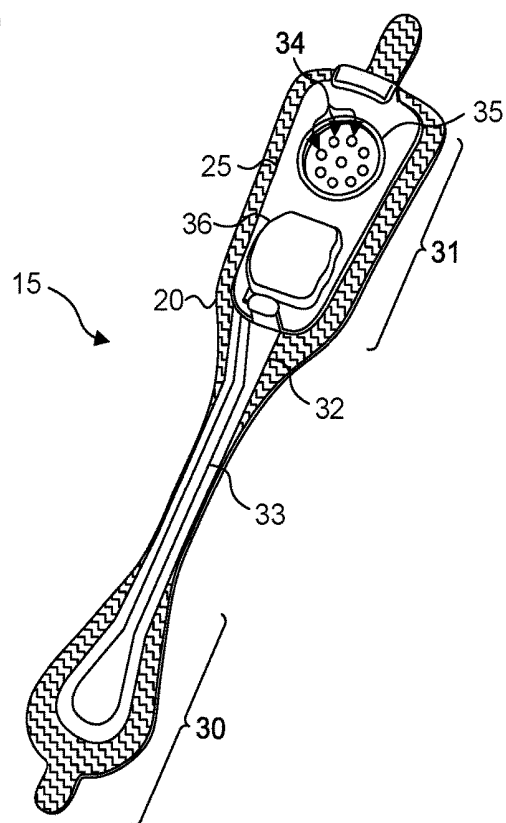


Fig. 5.

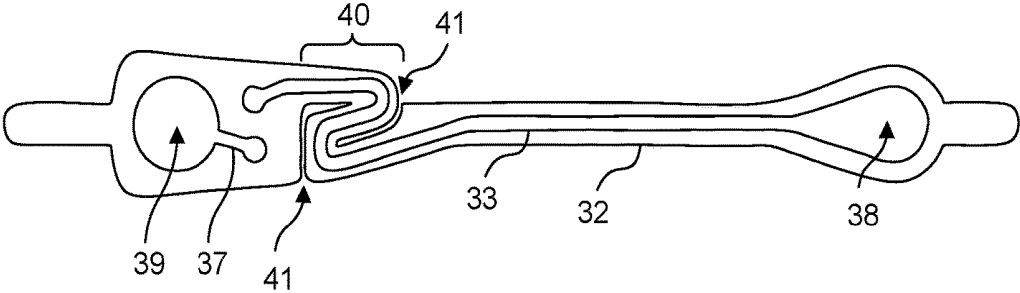
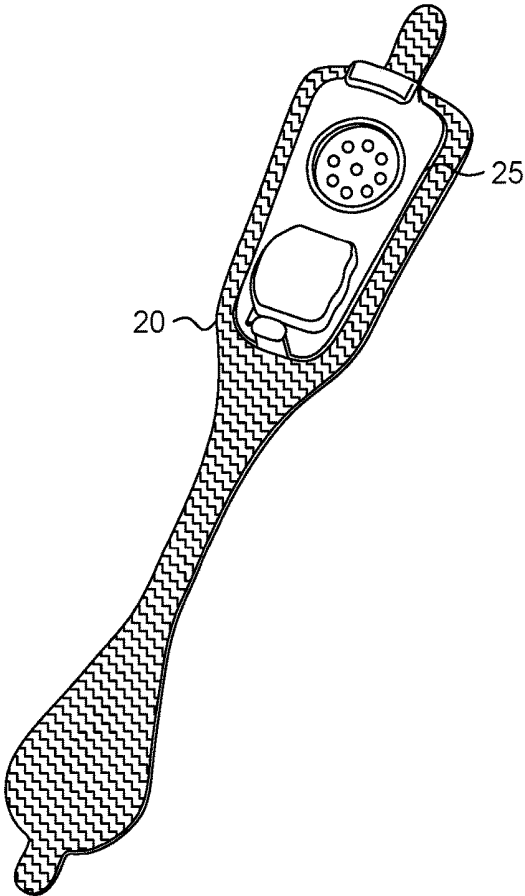
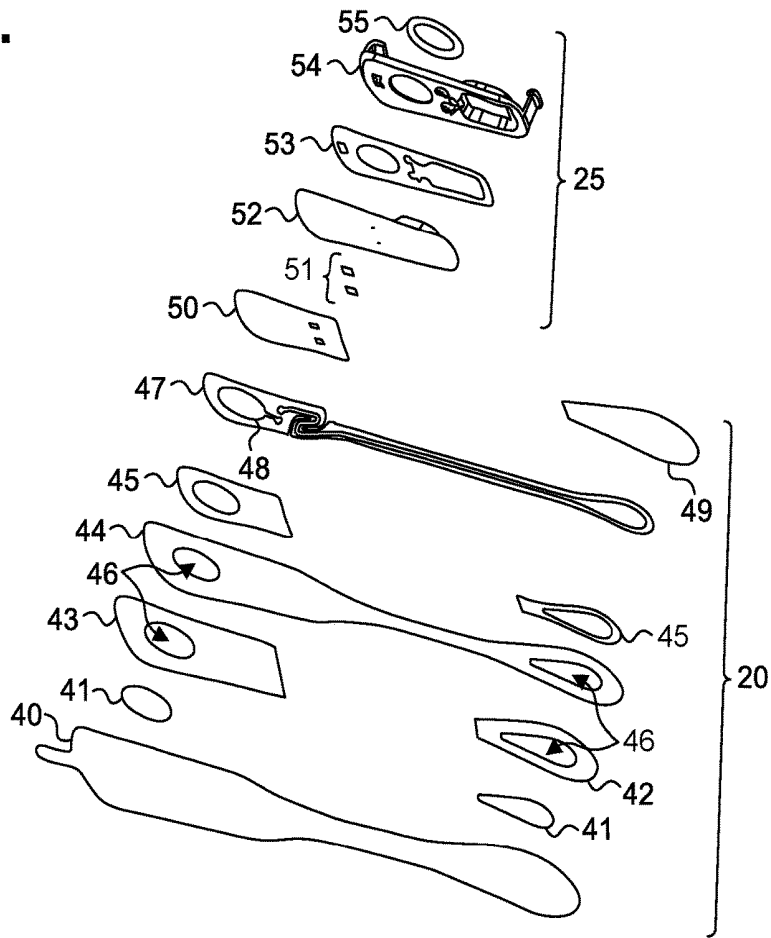


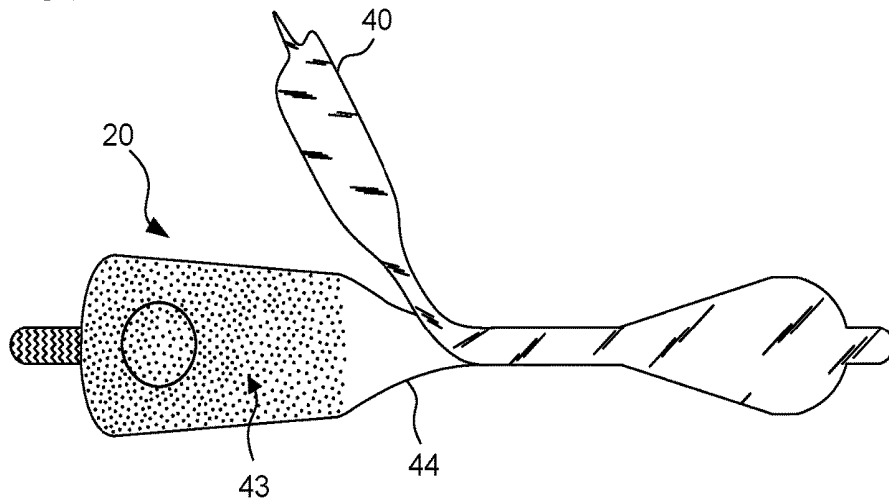
Fig. 6.



**Fig. 7.**



**Fig. 8.**



**Fig. 9.**

60

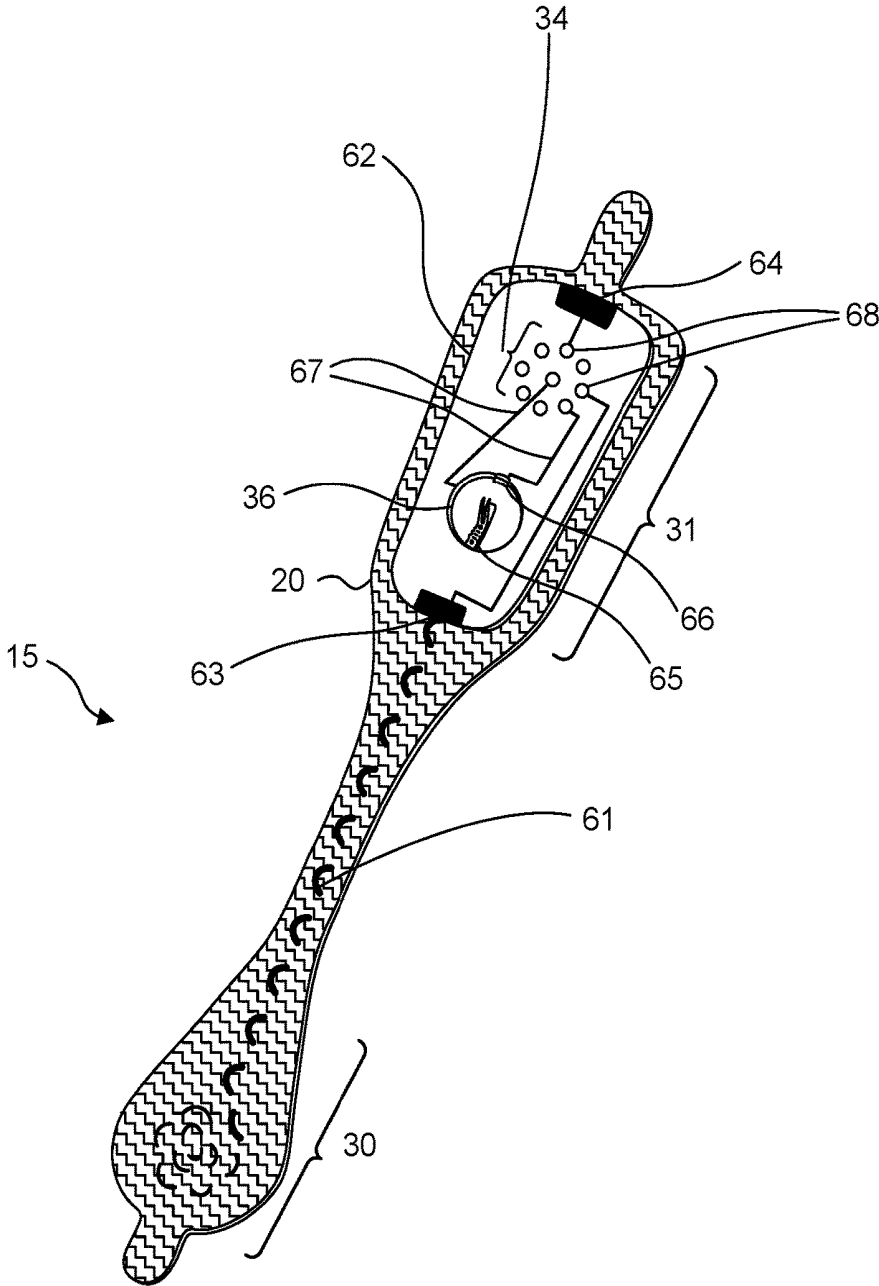
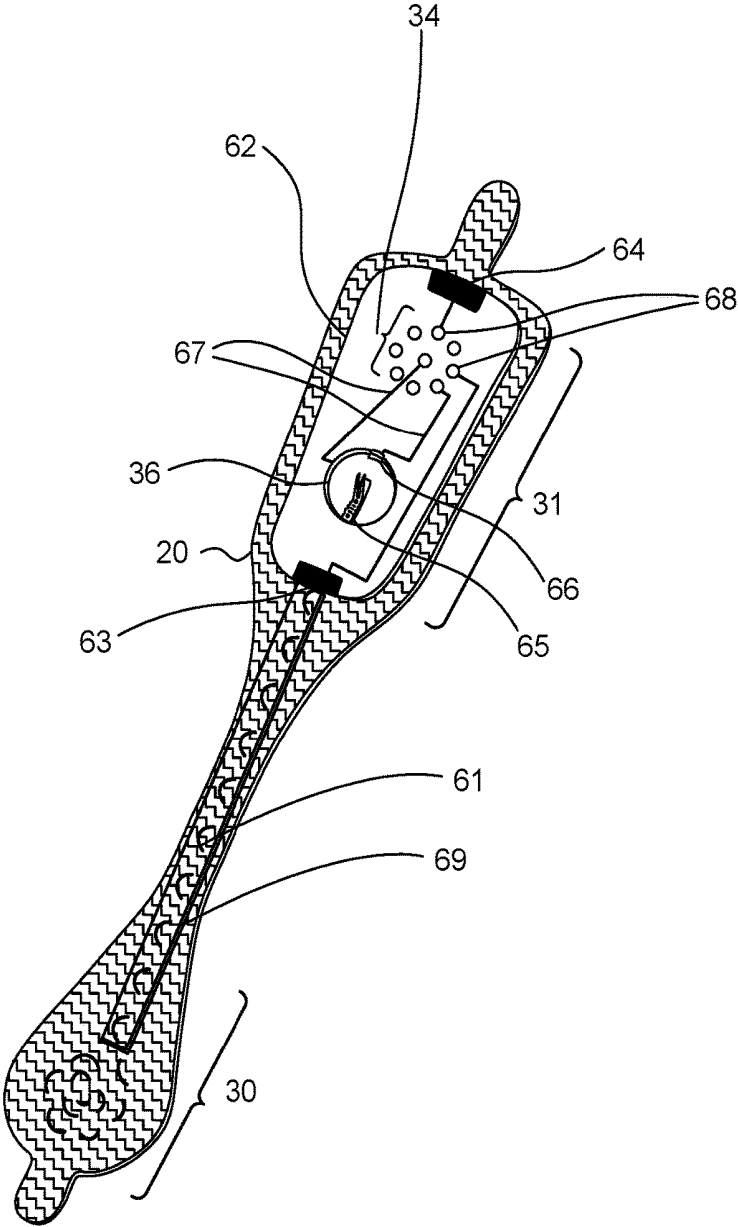
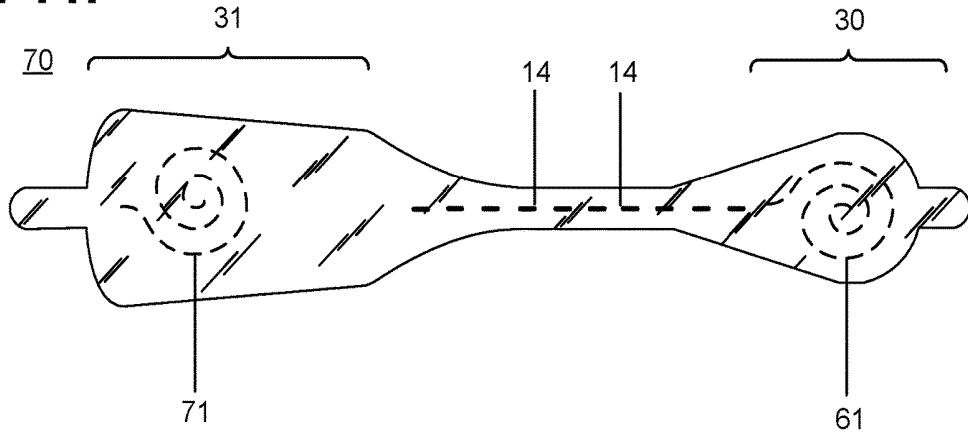


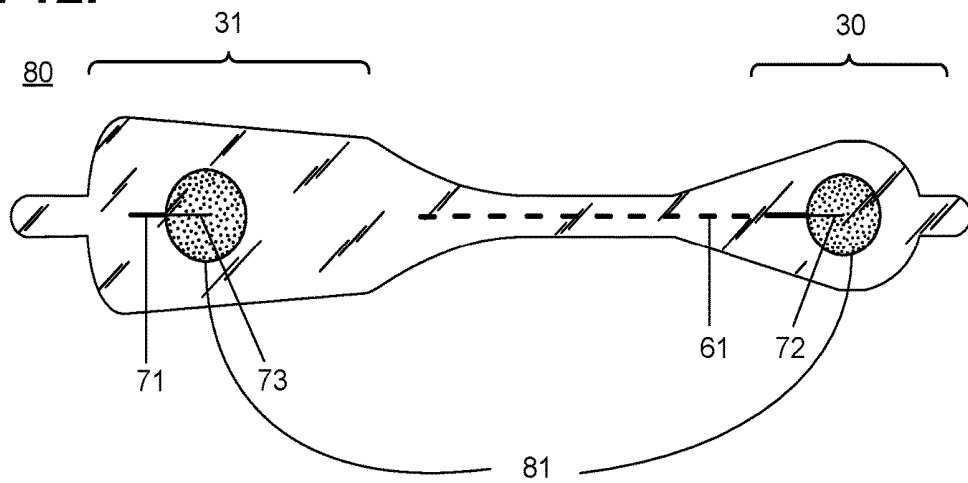
Fig. 10.



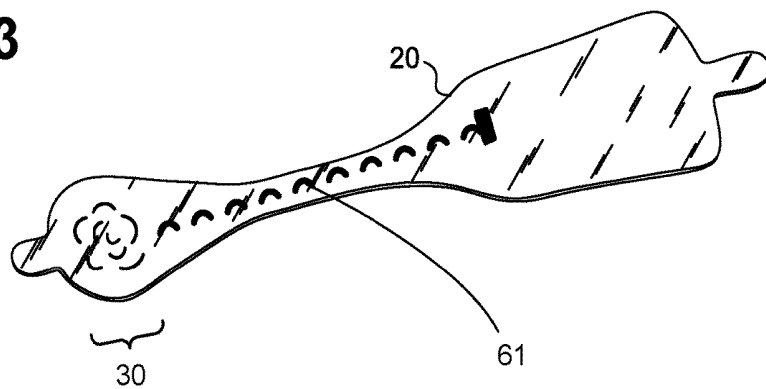
**Fig. 11.**



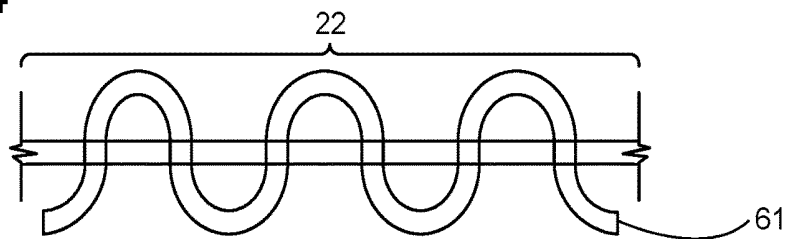
**Fig. 12.**



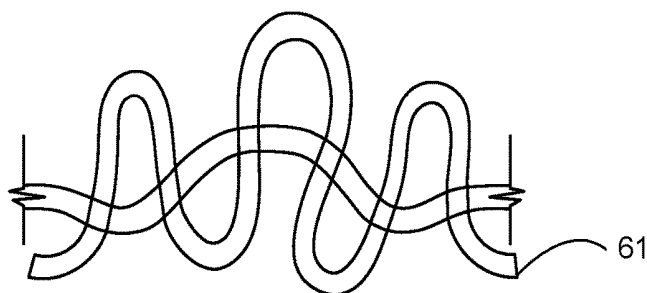
**Fig. 13**



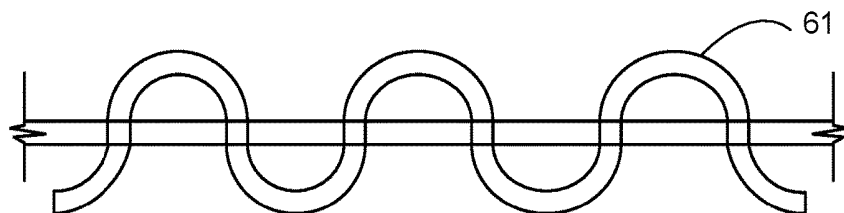
**Fig. 14**



**Fig. 15A.**



**Fig. 15B.**



**Fig. 15C.**

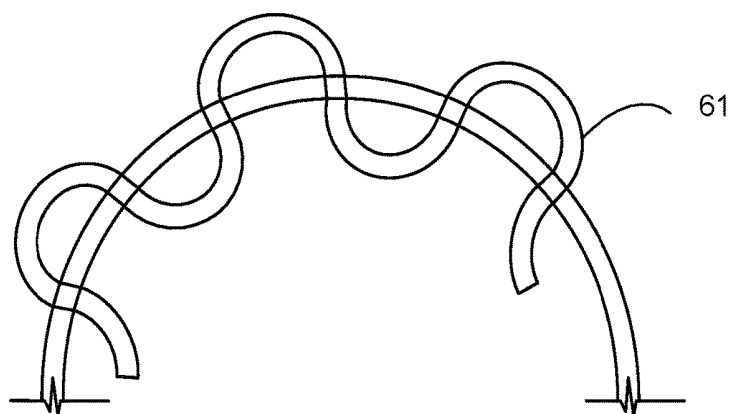
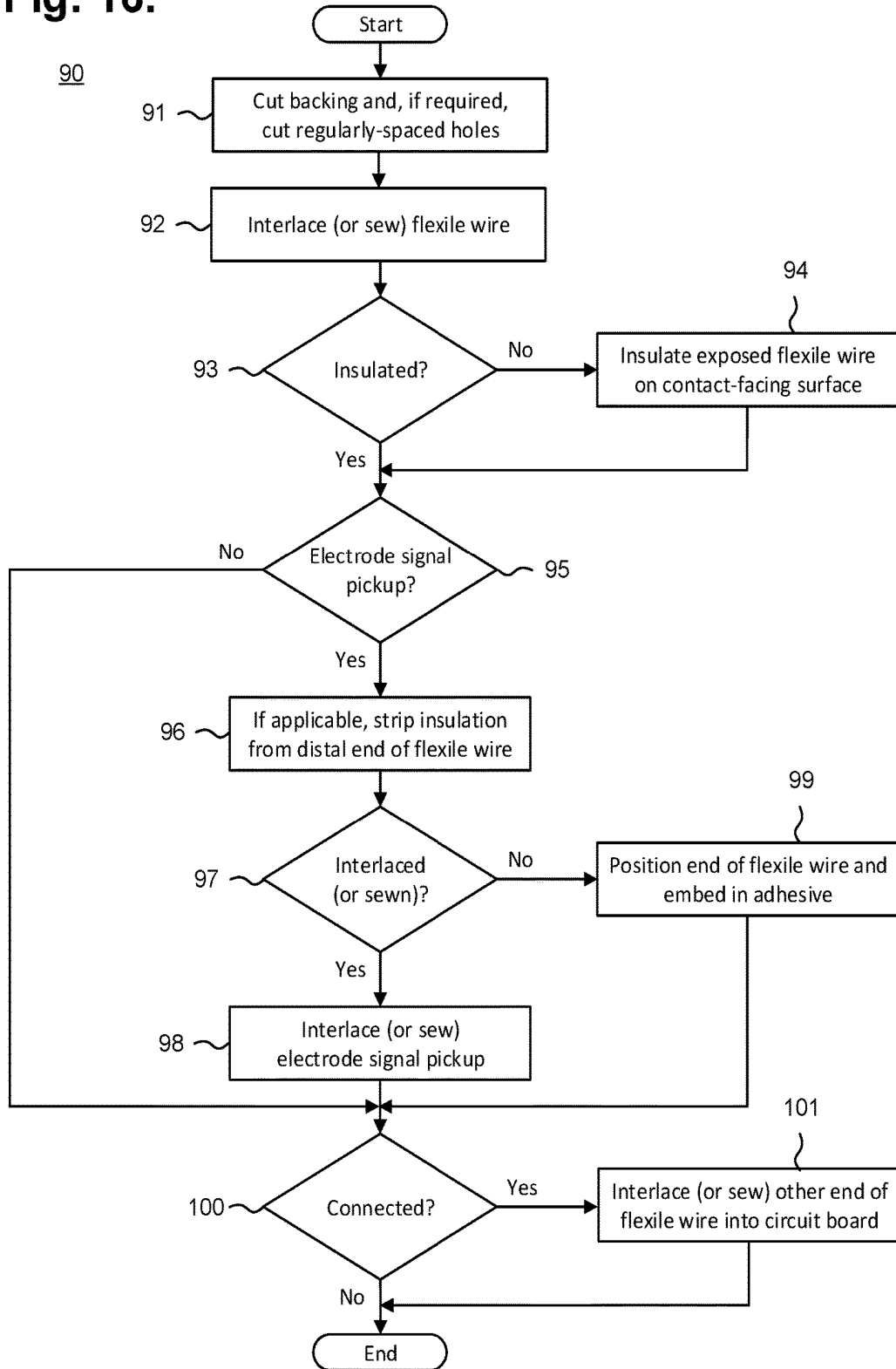
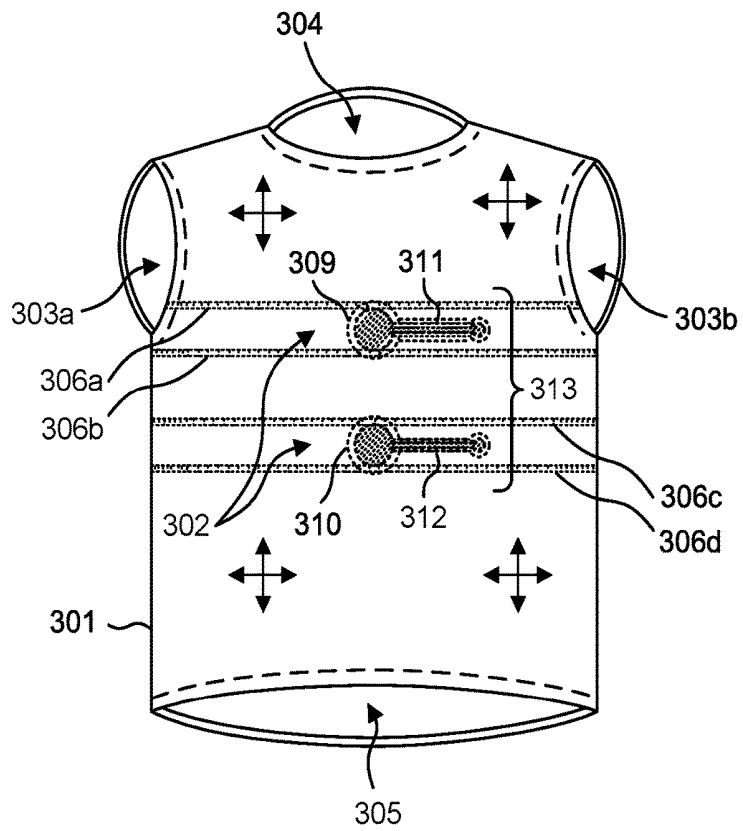


Fig. 16.



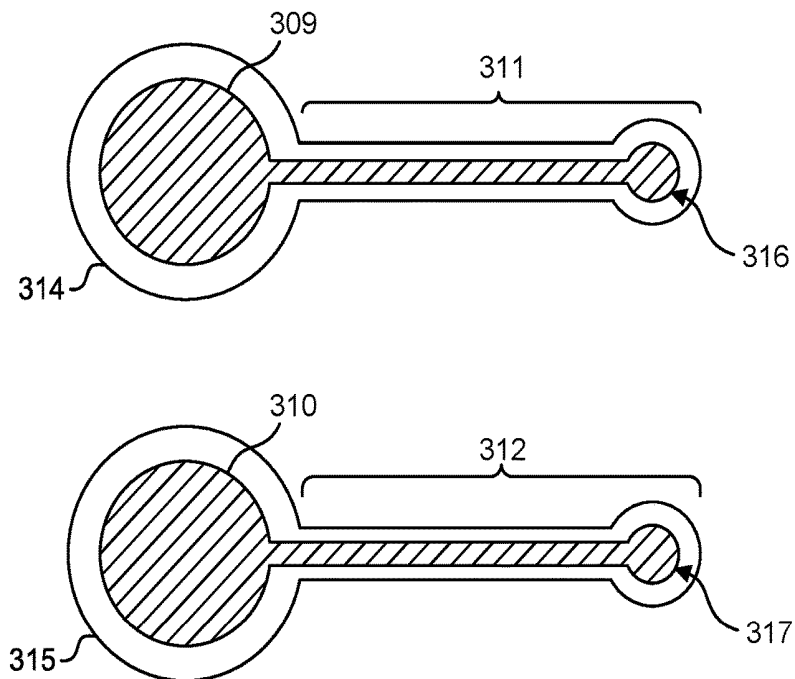
**Fig. 17.**

300

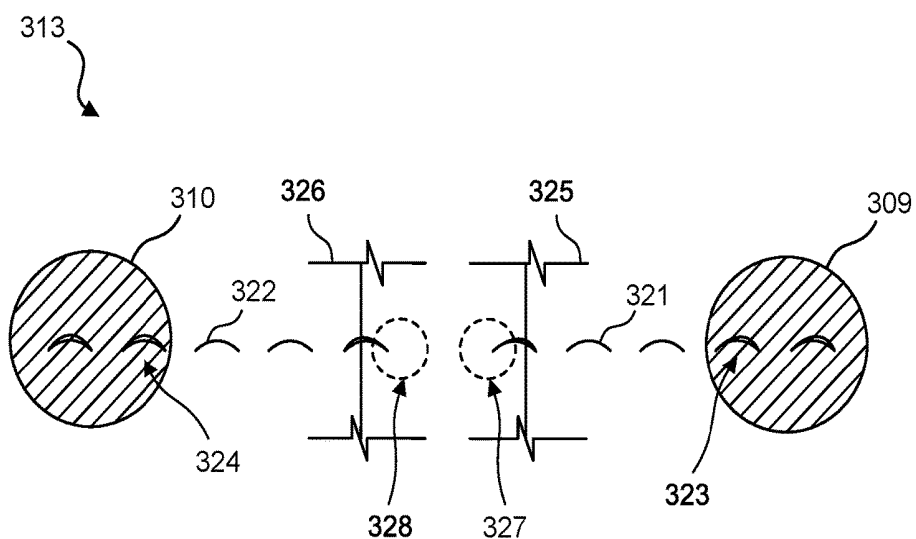


**Fig. 18.**

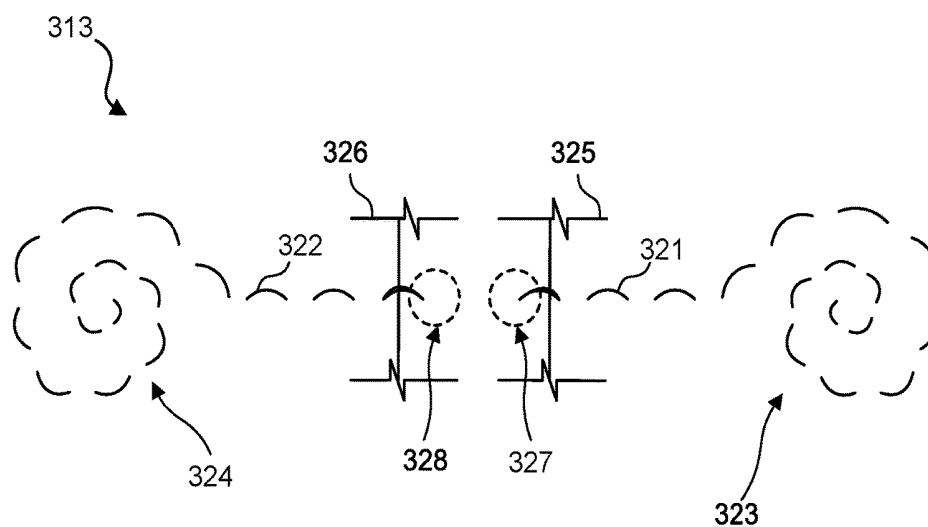
313



**Fig. 19.**



**Fig. 20.**



**WEARABLE ELECTROCARDIOGRAPHY  
AND PHYSIOLOGY MONITORING  
ENSEMBLE**

**CROSS-REFERENCE TO RELATED  
APPLICATION**

[0001] This non-provisional patent application is a continuation of U.S. patent application Ser. No. 15/602,003, filed May 22, 2017, pending, which is a continuation of U.S. Pat. No. 9,655,537, issued May 23, 2017, which is a continuation-in-part of U.S. Pat. No. 9,717,432, issued Aug. 1, 2017, which is a continuation-in-part of U.S. Pat. No. 9,545,204, issued Jan. 17, 2017, and further claims priority under 35 U.S.C. § 119(e) to U.S. Provisional Patent application, Ser. No. 61/882,403, filed Sep. 25, 2013, the disclosures of which are incorporated by reference.

**FIELD**

[0002] This application relates in general to electrocardiography and physiology monitoring and, in particular, to a wearable electrocardiography and physiology monitoring ensemble.

**BACKGROUND**

[0003] An electrocardiogram (ECG) measures and records electrical potential signals and visually depicts heart electrical activity over time. Conventionally, a standard 12-lead configuration is used in-clinic to record cardiac electrical signals from established chest locations. Physicians use ECGs to diagnose heart problems and other health concerns during appointments; however, spot ECG recording may not always detect sporadic conditions, including conditions affected by fluctuations in blood pressure, blood sugar, respiratory function, temperature, cardiac physiology and pathophysiology, or cardiac rhythm.

[0004] Physicians may provide improved diagnoses through ambulatory ECG monitoring that increases the odds of capturing sporadic conditions, during which a subject can also engage in activities of daily living. While long-term extended ambulatory monitoring in-clinic is implausible and impracticable, diagnostic efficacy can be improved through long-term extended ambulatory ECG monitoring. A 30-day observation period is considered the “gold standard,” but has heretofore proven unworkable because existing ECG monitoring systems have been arduous to employ, cumbersome to the patient, and expensive.

[0005] Extended ECG monitoring is further complicated by patient intolerance to long-term electrode wear and predisposition to skin irritation. Moreover, natural materials from the patient’s body, such as hair, sweat, skin oils, and dead skin cells, can get between an electrode, adhesives, and the skin’s surface, which can adversely affect electrode contact and cardiac signal recording quality. Patient physical movement and clothing can impart forces on the ECG electrode contact point; inflexibly fastened ECG electrodes are particularly prone to becoming dislodged. Precisely re-placing a dislodged ECG electrode may be essential to ensuring signal capture at the same fidelity. Dislodgment may occur unbeknownst to the patient, rendering the ECG recordings worthless.

[0006] The high cost of the patient-wearable components used to provide long-term extended ECG monitoring can also negatively influence the availability and use of moni-

tors. Disposable components, such as adhesive electrodes, ideally should be inexpensive, while more complex components, particularly the electronic hardware that detects and records ECG and related physiological data, may be unavoidably expensive. Costs can be balanced by designing the electric hardware to be re-usable, but when the total cost of a full ECG monitoring ensemble remains high, despite the utilization of re-usable parts, the number of monitors available for use by healthcare providers can be inhibited. Cost, then, becomes a barrier to entry, which, in turn, can hinder or prevent healthcare providers from obtaining the means with which to efficaciously identify the physiology underlying sporadic cardiac arrhythmic conditions and can ultimately contribute to a failure to make proper and timely medical diagnose.

[0007] ECG data are crucial for diagnosing many cardiovascular conditions. For example, detecting abnormal respiratory function with ECG data showing normal respiratory variation may facilitate diagnosis, prognosis, and treatment of certain disorders. Moreover, ECG data obtained through ambulatory monitoring, when combined with additional physiological data, can be especially helpful when diagnosing athletes, who present unique concerns not generally observed in a non-physically active patient population. For example, blood sugar plays a strong role in athletic performance and recovery and correlates with cardiac function. Monitoring respiratory and ECG together can help in diagnosing cardiorespiratory conditions common to athletes, especially since such conditions not only impair performance, but when combined with overtraining, a cardiorespiratory impairment may lead to severe or even terminal conditions, including severe bronchoconstriction or sudden death.

[0008] Existing portable devices that monitor cardiac data and other physiological data, at best, provide suboptimal results. Such devices can be inconvenient and may restrain movement; for example, a Holter device, which is a wearable ECG monitor with leads placed in a similar position as used with a standard ECG set-up, is cumbersome, expensive, typically only available by medical prescription, and requires skilled medical staff to properly position the electrodes.

[0009] Wrist monitors, such as the Fitbit product line of activity trackers, manufactured by Fitbit Inc., San Francisco, Calif., and related technologies, like wristwatch smartphones (also known as smartwatches), such as the Apple Watch, manufactured by Apple Inc., Cupertino, Calif. or the Gear S smartwatch, manufactured by Samsung Electronics Co., Ltd., Suwon, South Korea, as well as clothing embedded with sensors, such as the Hexoskin product line of wearable clothing, manufactured by Carré Technologies, Inc., Montreal, Quebec, Canada, all experience fidelity problems related to variation in electrode and sensor contact. Gaps in signal quality or interruptions or distortions of the data stream can lead to false positives and false negatives critical to understanding the relationship between physiological markers and medical events or needs.

[0010] U.S. Pat. No. 8,668,653, to Nagata, et al., discloses an ECG-monitoring shirt with a plurality of electrodes, including four limb electrodes and sensors disposed on a beltline. To fit each of the electrodes on the body surface of the examinee, a low-irritant acrylic adhesive, for example, may be applied on each of the electrodes that fit on the

body's surface. The use of adhered electrodes is incompatible in patients with a predisposition to skin irritation.

[0011] Therefore, a need remains for an ambulatory, extended-wear monitor that can be used by patients who are intolerant to adhesively-adhered electrodes; highly mobile individuals, such as athletes, whose movement will cause adhesively-adhered electrodes to become dislodged; and individuals of all types in whom the recording high-quality PQRSTU ECG data and related physiological data are desired.

#### SUMMARY

[0012] Long-term extended ECG monitoring can be provided through a form of ECG or physiological sensor embedded into clothing, rather than on the-skin electrodes. The garment is made of a material holding the sensor in place during extended wear through, for example, a compressible, breathable fabric. Electrodes are preferably placed on the garment to contact the skin along a wearer's sternal midline at specific positions to enhance P-wave detection and ECG. The electrodes are connected to an ECG monitor recorder that is either discrete from or affixed to the garment and obtains physiological telemetry through a wireless or electrical interface. Various types of physiological sensors can be provided.

[0013] One embodiment provides a wearable electrocardiography monitoring ensemble. A first receptacle is defined in a wearable garment by two horizontal bands placed across the wearable garment. A second receptacle is defined by two further horizontal bands positioned across the wearable garment and under the first receptacle. A first electrode assembly is positioned within the first receptacle and includes a backing with an electrical connection having an electrode on one end of the electrical connection and terminated at the other end of the electrical connection to connect with a monitor recorder. A second electrode assembly is positioned within the second receptacle and includes a backing with an electrical connection having an electrode on one end of the electrical connection and terminated at the other end of the electrical connection to connect with a further monitor recorder. The first and second electrodes are aligned longitudinally in the wearable garment.

[0014] The wearable monitoring ensemble creates a more natural experience for wearers and can be used to produce an expanded dataset for diagnosis because the ensemble can collect data during activities of daily living and can capture cardiovascular events outside of clinical observation, which is otherwise not practicable, especially for athletes.

[0015] Still other embodiments will become readily apparent to those skilled in the art from the following detailed description, wherein are described embodiments by way of illustrating the best mode contemplated. As will be realized, other and different embodiments are possible, and the embodiments' several details are capable of modifications in various obvious respects, all without departing from their spirit and the scope. Accordingly, the drawings and detailed description are to be regarded as illustrative in nature and not as restrictive.

#### BRIEF DESCRIPTION OF THE DRAWINGS

[0016] FIGS. 1 and 2 are diagrams showing, by way of examples, an extended wear electrocardiography monitor, including an extended wear electrode patch in accordance

with one embodiment, respectively fitted to the sternal region of a female and a male.

[0017] FIG. 3 is a perspective view showing an extended wear electrode patch in accordance with one embodiment with a monitor recorder inserted.

[0018] FIG. 4 is a perspective view showing the extended wear electrode patch of FIG. 3 without a monitor recorder inserted.

[0019] FIG. 5 is a top view showing the flexible circuit of the extended wear electrode patch of FIG. 3.

[0020] FIG. 6 is a perspective view showing the extended wear electrode patch in accordance with a further embodiment.

[0021] FIG. 7 is an exploded view showing the component layers of the electrode patch of FIG. 3.

[0022] FIG. 8 is a bottom plan view of the extended wear electrode patch of FIG. 3 with liner partially peeled back.

[0023] FIG. 9 is a perspective view of an extended wear electrode patch with a flexile wire electrode assembly in accordance with a still further embodiment.

[0024] FIG. 10 is perspective view of the flexile wire electrode assembly from FIG. 9, with a layer of insulating material shielding a bare distal wire around the midsection of the flexible backing.

[0025] FIG. 11 is a bottom view of the flexile wire electrode assembly as shown in FIG. 9.

[0026] FIG. 12 is a bottom view of a flexile wire electrode assembly in accordance with a still yet further embodiment.

[0027] FIG. 13 is a perspective view showing the longitudinal midsection of the flexible backing of the electrode assembly from FIG. 9.

[0028] FIG. 14 is a longitudinal cross-sectional view of the midsection of the flexible backing of the electrode assembly of FIG. 11.

[0029] FIGS. 15A-C are the electrode assembly from FIG. 14 under compressional, tensile, and bending force, respectively.

[0030] FIG. 16 is a flow diagram showing a method for constructing a stress-pliant physiological electrode assembly in accordance with a further embodiment.

[0031] FIG. 17 is a front view of a wearable electrocardiography and physiology monitoring ensemble in accordance with a further embodiment.

[0032] FIG. 18 is a contact-surface view of a flexible circuit electrode assembly of the wearable monitoring ensemble of FIG. 17.

[0033] FIG. 19 is a contact-surface view of a flexile wire interconnect of the wearable monitoring ensemble of FIG. 17.

[0034] FIG. 20 is a contact-surface view of a flexile wire electrode and interconnect of the wearable monitoring ensemble of FIG. 17.

#### DETAILED DESCRIPTION

[0035] Physiology monitoring can be provided through a wearable monitor that includes two components, a flexible extended wear electrode patch and a removable reusable monitor recorder. FIGS. 1 and 2 are diagrams showing, by way of examples, an extended wear electrocardiography monitor 12, including an extended wear electrode patch 15 in accordance with one embodiment, respectively fitted to the sternal region of a female 10 and a male 11. In a further embodiment, extended wear monitoring can be provided in the form of a wearable garment, as further described below

beginning with reference to FIG. 17 et seq. The wearable monitor 12 sits centrally (in the midline) on a human chest along the sternum 13 oriented top-to-bottom with the monitor recorder 14 preferably situated towards a human head. The electrode patch 15 is shaped to fit comfortably and conform to the contours of a human chest approximately centered on the sternal midline 16 (or immediately to either side of the sternum 13). The distal end of the electrode patch 15 extends towards the Xiphoid process and lower sternum and, depending upon a human build, may straddle the region over the Xiphoid process and lower sternum. The proximal end of the electrode patch 15, located under the monitor recorder 14, is below the manubrium and, depending upon a person's build, may straddle the region over the manubrium.

[0036] The placement of the wearable monitor 12 in a location at the sternal midline 16 (or immediately to either side of the sternum 13) significantly improves the ability of the wearable monitor 12 to cutaneously sense cardiac electric signals, particularly the P-wave (or atrial activity) and, to a lesser extent, the QRS interval signals in the ECG waveforms that indicate ventricular activity. The sternum 13 overlies the right atrium of the heart and the placement of the wearable monitor 12 in the region of the sternal midline 13 puts the ECG electrodes of the electrode patch 15 in a location better adapted to sensing and recording P-wave signals than other placement locations, say, the upper left pectoral region. In addition, placing the lower or inferior pole (ECG electrode) of the electrode patch 15 over (or near) the Xiphoid process and lower sternum facilitates sensing of right ventricular activity and provides superior recordation of the QRS interval.

[0037] During use, the electrode patch 15 is first adhered to the skin along the sternal midline 16 (or immediately to either side of the sternum 13). A monitor recorder 14 is then snapped into place on the electrode patch 15 to initiate ECG monitoring. FIG. 3 is a perspective view showing an extended wear electrode patch 15 in accordance with one embodiment with a monitor recorder 14 inserted. The body of the electrode patch 15 is preferably constructed using a flexible backing 20 formed as an elongated strip 21 of wrap knit or similar stretchable material about 145 mm long and 32 mm at the widest point with a narrow longitudinal mid-section 23 evenly tapering inward from both sides. A pair of cut-outs 22 between the distal and proximal ends of the electrode patch 15 create a narrow longitudinal midsection 23 or "isthmus" and defines an elongated "hourglass"-like shape, when viewed from above, such as described in commonly-assigned U.S. Pat. No. D744,659, issued Dec. 1, 2015, the disclosure of which is incorporated by reference. The upper part of the "hourglass" is sized to allow an electrically non-conductive receptacle 25, sits on top of the outward-facing surface of the electrode patch 15, to be affixed to the electrode patch 15 with an ECG electrode placed underneath on the wearer-facing underside, or contact, surface of the electrode patch 15; the upper part of the "hourglass" has a longer and wider profile than the lower part of the "hourglass," which is sized primarily to allow just the placement of an ECG electrode.

[0038] The electrode patch 15 incorporates features that significantly improve wearability, performance, and comfort throughout an extended monitoring period. The entire electrode patch 15 is lightweight in construction, which reduces shear forces and allows the patch to be resilient to disad-

hesis, displacement, or falling off and, critically, to avoid creating distracting discomfort, even when a person is asleep. In contrast, the weight of a heavy ECG monitor impedes wearer mobility and will cause the monitor to constantly tug downwards and press on the wearer's body; frequent adjustments by the wearer are needed to maintain comfort.

[0039] During every day wear, the electrode patch 15 is subjected to pushing, pulling, and torsional movements, including compressional and torsional forces when the wearer bends forward, and tensile and torsional forces when the wearer leans backwards. To counter these stress forces, the electrode patch 15 incorporates crimp and strain reliefs, as further described infra respectively with reference to FIGS. 4 and 5. In addition, the cut-outs 22 and longitudinal midsection 23 help minimize interference with and discomfort to breast tissue, particularly in women (and gynecomastic men). The cut-outs 22 and longitudinal midsection 23 allow better conformity of the electrode patch 15 to sternal bowing and to the narrow isthmus of flat skin that can occur along the bottom of the intermammary cleft between the breasts, especially in buxom women. The cut-outs 22 and longitudinal midsection 23 help the electrode patch 15 fit nicely between a pair of female breasts in the intermammary cleft. In one embodiment, the cut-outs 22 can be graduated to form the longitudinal midsection 23 as a narrow in-between stem or isthmus portion about 7 mm wide. In a still further embodiment, tabs 24 can respectively extend an additional 8 mm to 12 mm beyond the distal and proximal ends of the flexible backing 20 to facilitate purchase when adhering the electrode patch 15 to or removing the electrode patch 15 from the sternum 13. These tabs preferably lack adhesive on the underside, or contact, surface of the electrode patch 15. Still other shapes, cut-outs and conformities to the electrode patch 15 are possible.

[0040] The monitor recorder 14 removably and reusably snaps into an electrically non-conductive receptacle 25 during use. The monitor recorder 14 contains electronic circuitry for recording and storing the wearer's electrocardiography as sensed via a pair of ECG electrodes provided on the electrode patch 15, such as described in commonly-assigned U.S. Pat. No. 9,730,593, the disclosure of which is incorporated by reference. The circuitry includes a microcontroller, flash storage, ECG signal processing, analog-to-digital conversion (where applicable), and an external interface for coupling to the electrode patch 15 and to a download station for stored data download and device programming. The monitor recorder 14 also includes external wearer-interfaceable controls, such as a push button to facilitate event marking and provide feedback. In a further embodiment, the circuitry, with the assistance of the appropriate types of deployed electrodes or sensors, is capable of monitoring other types of physiology, in addition to ECGs. Still other types of monitor recorder components and functionality are possible.

[0041] The non-conductive receptacle 25 is provided on the top surface of the flexible backing 20 with a retention catch 26 and tension clip 27 molded into the non-conductive receptacle 25 to conformably receive and securely hold the monitor recorder 14 in place. The edges of the bottom surface of the non-conductive receptacle 25 are preferably rounded, and the monitor recorder 14 is nestled inside the

interior of the non-conductive receptacle **25** to present a rounded (gentle) surface, rather than a sharp edge at the skin-to-device interface.

[0042] The electrode patch **15** is intended to be disposable. The monitor recorder **14**, however, is reusable and can be transferred to successive electrode patches **15** to ensure continuity of monitoring. The placement of the wearable monitor **12** in a location at the sternal midline **16** (or immediately to either side of the sternum **13**) benefits long-term extended wear by removing the requirement that ECG electrodes be continually placed in the same spots on the skin throughout the monitoring period. Instead, the wearer is free to place an electrode patch **15** anywhere within the general region of the sternum **13**.

[0043] As a result, at any point during ECG monitoring, the wearer's skin is able to recover from the wearing of an electrode patch **15**, which increases wearer comfort and satisfaction, while the monitor recorder **14** ensures ECG monitoring continuity with minimal effort. A monitor recorder **14** is merely unsnapped from a worn out electrode patch **15**, the worn out electrode patch **15** is removed from the skin, a new electrode patch **15** is adhered to the skin, possibly in a new spot immediately adjacent to the earlier location, and the same monitor recorder **14** is snapped into the new electrode patch **15** to reinitiate and continue the ECG monitoring.

[0044] During use, the electrode patch **15** is first adhered to the skin in the sternal region. FIG. 4 is a perspective view showing the extended wear electrode patch **15** of FIG. 3 without a monitor recorder **14** inserted. A flexible circuit **32** is adhered to each end of the flexible backing **20**. A distal circuit trace **33** from the distal end **30** of the flexible backing **20** and a proximal circuit trace (not shown) from the proximal end **31** of the flexible backing **20** electrically couple ECG electrodes (not shown) with a pair of electrical pads **34**. In a further embodiment, the distal and proximal circuit traces are replaced with interlaced or sewn-in flexible wires, as further described infra beginning with reference to FIG. 9. The electrical pads **34** are provided within a moisture-resistant seal **35** formed on the bottom surface of the non-conductive receptacle **25**. When the monitor recorder **14** is securely received into the non-conductive receptacle **25**, that is, snapped into place, the electrical pads **34** interface to electrical contacts (not shown) protruding from the bottom surface of the monitor recorder **14**. The moisture-resistant seal **35** enables the monitor recorder **14** to be worn at all times, even during bathing or other activities that could expose the monitor recorder **14** to moisture or adverse conditions.

[0045] In addition, a battery compartment **36** is formed on the bottom surface of the non-conductive receptacle **25**. A pair of battery leads (not shown) from the battery compartment **36** to another pair of the electrical pads **34** electrically interface the battery to the monitor recorder **14**. The battery contained within the battery compartment **35** can be replaceable, rechargeable or disposable.

[0046] The monitor recorder **14** draws power externally from the battery provided in the non-conductive receptacle **25**, thereby uniquely obviating the need for the monitor recorder **14** to carry a dedicated power source. The battery contained within the battery compartment **36** can be replaceable, rechargeable or disposable. In a further embodiment, the ECG sensing circuitry of the monitor recorder **14** can be supplemented with additional sensors, including an SpO<sub>2</sub>

sensor, a blood pressure sensor, a temperature sensor, respiratory rate sensor, a glucose sensor, an air flow sensor, and a volumetric pressure sensor, which can be incorporated directly into the monitor recorder **14** or onto the non-conductive receptacle **25**.

[0047] The placement of the flexible backing **20** on the sternal midline **16** (or immediately to either side of the sternum **13**) also helps to minimize the side-to-side movement of the wearable monitor **12** in the left- and right-handed directions during wear. However, the wearable monitor **12** is still susceptible to pushing, pulling, and torquing movements, including compressional and torsional forces when the wearer bends forward, and tensile and torsional forces when the wearer leans backwards. To counter the dislodgment of the flexible backing **20** due to compressional and torsional forces, a layer of non-irritating adhesive, such as hydrocolloid, is provided at least partially on the underside, or contact, surface of the flexible backing **20**, but only on the distal end **30** and the proximal end **31**. As a result, the underside, or contact surface of the longitudinal midsection **23** does not have an adhesive layer and remains free to move relative to the skin. Thus, the longitudinal midsection **23** forms a crimp relief that respectively facilitates compression and twisting of the flexible backing **20** in response to compressional and torsional forces. Other forms of flexible backing crimp reliefs are possible.

[0048] Unlike the flexible backing **20**, the flexible circuit **32** is only able to bend and cannot stretch in a planar direction. FIG. 5 is a top view showing the flexible circuit **32** of the extended wear electrode patch **15** of FIG. 3. A distal ECG electrode **38** and proximal ECG electrode **39** are respectively coupled to the distal and proximal ends of the flexible circuit **32** to serve as electrode signal pickups. The flexible circuit **32** preferably does not extend to the outside edges of the flexible backing **20**, thereby avoiding gouging or discomforting the wearer's skin during extended wear, such as when sleeping on the side. During wear, the ECG electrodes **38**, **39** must remain in continual contact with the skin. A strain relief **40** is defined in the flexible circuit **32** at a location that is partially underneath the battery compartment **36** when the flexible circuit **32** is affixed to the flexible backing **20**. The strain relief **40** is laterally extendable to counter dislodgment of the ECG electrodes **38**, **39** due to tensile and torsional forces. A pair of strain relief cutouts **41** partially extend transversely from each opposite side of the flexible circuit **32** and continue longitudinally towards each other to define in 'S'-shaped pattern, when viewed from above. The strain relief respectively facilitates longitudinal extension and twisting of the flexible circuit **32** in response to tensile and torsional forces. Other forms of circuit board strain relief are possible.

[0049] The flexible circuit **32** can be provided either above or below the flexible backing **20**. FIG. 6 is a perspective view showing the extended wear electrode patch **15** in accordance with a further embodiment. The flexible circuit (not shown) is provided on the underside, or contact, surface of the flexible backing **20** and is electrically interfaced to the set of electrical pads **34** on the bottom surface of the non-conductive receptacle **25** through electrical contacts (not shown) pierced through the flexible backing **20**.

[0050] The electrode patch **15** is intended to be a disposable component, which enables a wearer to replace the electrode patch **15** as needed throughout the monitoring period, while maintaining continuity of physiological sens-

ing through reuse of the same monitor recorder 14. FIG. 7 is an exploded view showing the component layers of the electrode patch 15 of FIG. 3. The flexible backing 20 is constructed of a wearable gauze, latex, woven textile, or similar wrap knit or stretchable and wear-safe material 44, such as a Tricot-type linen with a pressure sensitive adhesive (PSA) on the underside, or contact, surface. The ends of the wearable material 44 are coated with a layer 43 of non-irritating adhesive, such as hydrocolloid, to facilitate long-term wear, while the unadhesed narrowed midsection rides freely over the skin. The hydrocolloid, for instance, is typically made of mineral oil, cellulose and water and lacks any chemical solvents, so should cause little itching or irritation. Moreover, hydrocolloid can be manufactured into an appropriate thickness and plasticity and provides cushioning between the relatively rigid and unyielding non-conductive receptacle 25 and the wearer's skin. In a further embodiment, the layer of non-irritating adhesive can be contoured, such as by forming the adhesive with a concave or convex cross-section; surfaced, such as through stripes or crosshatches of adhesive, or by forming dimples in the adhesive's surface; or applied discontinuously, such as with a formation of discrete dots of adhesive.

[0051] As described supra with reference to FIG. 5, a flexible circuit can be adhered to either the outward facing surface or the underside, or contact, surface of the flexible backing 20. For convenience, a flexible circuit 47 is shown relative to the outward facing surface of the wearable material 44 and is adhered respectively on a distal end by a distal electrode seal 45 and on a proximal end by a proximal electrode seal 45. In a further embodiment, the flexible circuit 47 can be provided on the underside, or contact, surface of the wearable material 44. Through the electrode seals, only the distal and proximal ends of the flexible circuit 47 are attached to the wearable material 44, which enables the strain relief 40 (shown in FIG. 5) to respectively longitudinally extend and twist in response to tensile and torsional forces during wear. Similarly, the layer 43 of non-irritating adhesive is provided on the underside, or contact, surface of the wearable material 44 only on the proximal and distal ends, which enables the longitudinal midsection 23 (shown in FIG. 3) to respectively bow outward and away from the sternum 13 or twist in response to compressional and torsional forces during wear.

[0052] A pair of openings 46 is defined on the distal and proximal ends of the wearable material 44 and layer 43 of non-irritating adhesive for ECG electrodes 38, 39 (shown in FIG. 5). The openings 46 serve as "gel" wells with a layer of hydrogel 41 being used to fill the bottom of each opening 46 as a conductive material that aids electrode signal capture. The entire underside, or contact, surface of the flexible backing 20 is protected prior to use by a liner layer 40 that is peeled away, as shown in FIG. 8.

[0053] The non-conductive receptacle 25 includes a main body 54 that is molded out of polycarbonate, ABS, or an alloy of those two materials to provide a high surface energy to facilitate adhesion of an adhesive seal 53. The main body 54 is attached to a battery printed circuit board 52 by the adhesive seal 53 and, in turn, the battery printed circuit board 52 is adhered to the flexible circuit 47 with an upper flexible circuit seal 50. A pair of conductive transfer adhesive points 51 or, alternatively, soldered connections, or electromechanical connections, including metallic rivets or similar conductive and structurally unifying components,

connect the circuit traces 33, 37 (shown in FIG. 5) of the flexible circuit 47 to the battery printed circuit board 52. The main body 54 has a retention catch 26 and tension clip 27 (shown in FIG. 3) that fixably and securely receive a monitor recorder 14 (not shown), and includes a recess within which to circumferentially receive a die cut gasket 55, either rubber, urethane foam, or similar suitable material, to provide a moisture resistant seal to the set of pads 34. Other types of design, arrangement, and permutation are possible.

[0054] In a still further embodiment, the flexible circuit 32 (shown in FIG. 4) and distal ECG electrode 38 and proximal ECG electrode 39 (shown in FIG. 5) are replaced with a pair of interlaced flexile wires. The interlacing of flexile wires through the flexible backing 20 reduces both manufacturing costs and environmental impact, as further described infra. The flexible circuit and ECG electrodes are replaced with a pair of flexile wires that serve as both electrode circuit traces and electrode signal pickups. FIG. 9 is a perspective view of an extended wear electrode patch 15 with a flexile wire electrode assembly in accordance with a still further embodiment. The flexible backing 20 maintains the unique narrow "hourglass"-like shape that aids long term extended wear, particularly in women, as described supra with reference to FIG. 3. For clarity, the non-conductive receptacle 25 is omitted to show the exposed battery printed circuit board 62 that is adhered underneath the non-conductive receptacle 25 to the proximal end 31 of the flexible backing 20. Instead of employing flexible circuits, a pair of flexile wires are separately interlaced or sewn into the flexible backing 20 to serve as circuit connections for an anode electrode lead and for a cathode electrode lead.

[0055] To form a distal electrode assembly, a distal wire 61 is interlaced into the distal end 30 of the flexible backing 20, continues along an axial path through the narrow longitudinal midsection of the elongated strip, and electrically connects to the battery printed circuit board 62 on the proximal end 31 of the flexible backing 20. The distal wire 61 is connected to the battery printed circuit board 62 by stripping the distal wire 61 of insulation, if applicable, and interlacing or sewing the uninsulated end of the distal wire 61 directly into an exposed circuit trace 63. The distal wire-to-battery printed circuit board connection can be made, for instance, by back stitching the distal wire 61 back and forth across the edge of the battery printed circuit board 62. Similarly, to form a proximal electrode assembly, a proximal wire (not shown) is interlaced into the proximal end 31 of the flexible backing 20. The proximal wire is connected to the battery printed circuit board 62 by stripping the proximal wire of insulation, if applicable, and interlacing or sewing the uninsulated end of the proximal wire directly into an exposed circuit trace 64. The resulting flexile wire connections both establish electrical connections and help to affix the battery printed circuit board 62 to the flexible backing 20.

[0056] The battery printed circuit board 62 is provided with a battery compartment 36. A set of electrical pads 34 are formed on the battery printed circuit board 62. The electrical pads 34 electrically interface the battery printed circuit board 62 with a monitor recorder 14 when fitted into the non-conductive receptacle 25. The battery compartment 36 contains a spring 65 and a clasp 66, or similar assembly, to hold a battery (not shown) in place and electrically interfaces the battery to the electrical pads 34 through a pair battery leads 67 for powering the electrocardiography moni-

tor 14. Other types of battery compartment are possible. The battery contained within the battery compartment 36 can be replaceable, rechargeable, or disposable.

[0057] In a yet further embodiment, the circuit board and non-conductive receptacle 25 are replaced by a combined housing that includes a battery compartment and a plurality of electrical pads. The housing can be affixed to the proximal end of the elongated strip through the interlacing or sewing of the flexile wires or other wires or threads.

[0058] The core of the flexile wires may be made from a solid, stranded, or braided conductive metal or metal compounds. In general, a solid wire will be less flexible than a stranded wire with the same total cross-sectional area, but will provide more mechanical rigidity than the stranded wire. The conductive core may be copper, aluminum, silver, or other material. The pair of the flexile wires may be provided as insulated wire. In one embodiment, the flexile wires are made from a magnet wire from Belden Cable, catalogue number 8051, with a solid core of AWG 22 with bare copper as conductor material and insulated by polyurethane or nylon. Still other types of flexile wires are possible. In a further embodiment, conductive ink or graphene can be used to print electrical connections, either in combination with or in place of the flexile wires.

[0059] In a still further embodiment, the flexile wires are uninsulated. FIG. 10 is perspective view of the flexile wire electrode assembly from FIG. 9, with a layer of insulating material 69 shielding a bare uninsulated distal wire 61 around the midsection on the contact side of the flexible backing. On the contact side of the proximal and distal ends of the flexible backing, only the portions of the flexile wires serving as electrode signal pickups are electrically exposed and the rest of the flexile wire on the contact side outside of the proximal and distal ends are shielded from electrical contact. The bare uninsulated distal wire 61 may be insulated using a layer of plastic, rubber-like polymers, or varnish, or by an additional layer of gauze or adhesive (or non-adhesive) gel. The bare uninsulated wire 61 on the non-contact side of the flexible backing may be insulated or can simply be left uninsulated.

[0060] Both end portions of the pair of flexile wires are typically placed uninsulated on the contact surface of the flexible backing 20 to form a pair of electrode signal pickups. FIG. 11 is a bottom view of the flexile wire electrode assembly as shown in FIG. 9. When adhered to the skin during use, the uninsulated end portions of the distal wire 61 and the proximal wire 71 enable the monitor recorder 14 to measure dermal electrical potential differentials. At the proximal and distal ends of the flexible backing 20, the uninsulated end portions of the flexile wires may be configured into an appropriate pattern to provide an electrode signal pickup, which would typically be a spiral shape formed by guiding the flexile wire along an inwardly spiraling pattern. The surface area of the electrode pickups can also be variable, such as by selectively removing some or all of the insulation on the contact surface. For example, an electrode signal pickup arranged by sewing insulated flexile wire in a spiral pattern could have a crescent-shaped cutout of uninsulated flexile wire facing towards the signal source.

[0061] In a still yet further embodiment, the flexile wires are left freely riding on the contact surfaces on the distal and proximal ends of the flexible backing, rather than being interlaced into the ends of the flexible backing 20. FIG. 12 is a bottom view of a flexile wire electrode assembly in

accordance with a still yet further embodiment. The distal wire 61 is interlaced onto the midsection and extends an exposed end portion 72 onto the distal end 30. The proximal wire 71 extends an exposed end portion 73 onto the proximal end 31. The exposed end portions 72 and 73, not shielded with insulation, are further embedded within an electrically conductive adhesive 81. The adhesive 81 makes contact to skin during use and conducts skin electrical potentials to the monitor recorder 14 (not shown) via the flexile wires. The adhesive 81 can be formed from electrically conductive, non-irritating adhesive, such as hydrocolloid.

[0062] The distal wire 61 is interlaced or sewn through the longitudinal midsection of the flexible backing 20 and takes the place of the flexible circuit 32. FIG. 13 is a perspective view showing the longitudinal midsection of the flexible backing of the electrode assembly from FIG. 9. Various stitching patterns may be adopted to provide a proper combination of rigidity and flexibility. In simplest form, the distal wire 61 can be manually threaded through a plurality of holes provided at regularly-spaced intervals along an axial path defined between the battery printed circuit board 62 (not shown) and the distal end 30 of the flexible backing 20. The distal wire 61 can be threaded through the plurality of holes by stitching the flexile wire as a single "thread." Other types of stitching patterns or stitching of multiple "threads" could also be used, as well as using a sewing machine or similar device to machine-stitch the distal wire 61 into place, as further described infra. Further, the path of the distal wire 61 need not be limited to a straight line from the distal to the proximal end of the flexible backing 20.

[0063] The distal wire 61 is flexile yet still retains a degree of rigidity that is influenced by wire gauge, composition, stranding, insulation, and stitching pattern. For example, rigidity decreases with wire gauge; and a solid core wire tends to be more rigid than a stranded core of the same gauge. The combination of the flexibility and the rigidity of the portion of the distal wire 61 located on or close to the midsection contributes to the overall strength and wearability of the patch. FIG. 14 is a longitudinal cross-sectional view of the midsection of the flexible backing 20 of the electrode assembly of FIG. 11. FIGS. 15A-C are the electrode assembly from FIG. 14 under compressional, tensile, and bending force, respectively. The relative sizes of the distal wire 61 and flexible backing 20 are not to scale and are exaggerated for purposes of illustration.

[0064] The interlacing of the distal wire 61 through the narrow longitudinal midsection 22 of the flexible backing 20 bends the distal wire 61 into a line of rounded stitches that alternate top and bottom, which can be advantageous to long term wearability. First, the tension of the rounded stitches reinforces the planar structure of the narrow longitudinal midsection 22 and spreads a dislodging force impacting on one end of the flexible backing 20 to the other end of the flexible backing 20. Second, the rounded stitches leave room for stretching, compressing, bending, and twisting, thus increasing the wearability of the patch extended wear electrode patch 15 by facilitating extension, compression, bending, and twisting of the narrow longitudinal midsection 22 in response to tensile, compressional, bending, and torsional forces.

[0065] In a further embodiment, the distal wire and the proximal wire may be stitched or sewn into the flexible backing 20. Depending upon the type of stitching used, the distal or proximal wire may use more than one individual

wire. For instance, a conventional sewing machine used to stitch fabrics uses a spool of thread and a bobbin, which are both wound with thread that together allow the creation of various stitching patterns, such as the lockstitch. Other type of stitching patterns are possible. Additionally, where more than one “threads” are used for stitching, the flexile wire may constitute all of the “threads,” thereby increasing redundancy of the circuit trace thus formed. Alternatively, just one (or fewer than all) of the threads may be conductive, with the non-conductive threads serving to reinforce the strength of the flexile wire connections and flexible backing 20. The additional threads can be made from line, threads, or fabrics of sufficient mechanical strength and do not need to be conductive; alternatively, the same flexile wires can be employed to serve as the additional threads.

[0066] Conventionally, flexible circuits, such as the flexible circuit 32 (shown in FIG. 4) that connects the distal ECG electrode 38 and proximal ECG electrode 39 (shown in FIG. 5) to the battery printed circuit board 62 (shown in FIG. 9), are constructed using subtractive processes. In general, a flexible circuit interconnects electronic components with custom point-to-point circuit traces and is typically constructed by forming the conductive circuit traces on a thin film of insulating polymer. A flexible circuit is not an off-the-shelf component; rather, each flexible circuit is designed with a specific purpose in mind. Changes to a flexible circuit’s design will generally require fabricating entirely new flexible circuits, as the physical circuit traces on the polymer film cannot be changed.

[0067] Manufacturing a flexible circuit typically requires the use of sophisticated and specialized tools, coupled with environmentally unfriendly processes, including depositing copper on a polyamide core, etching away unwanted copper with inline etching or an acid bath to retain only the desired conductive circuit traces, and applying a coverlay to the resulting flexible circuit. Significant amounts of hazardous waste are generated by these subtractive processes during the fabrication of each flexible circuit. Properly disposing of such hazardous waste is expensive and adds to the costs of the flexible circuit.

[0068] In the still further embodiment described supra beginning with reference to FIG. 9, the distal and proximal flexile wires replace the flexible circuit 32 and enables the electrode assembly to be constructed using additive processes with off-the-shelf, low cost components. The flexile wires serve the triple functions of an electrode signal pickup, electrical circuit trace, and support for structural integrity and malleability of the electrode assembly.

[0069] The general manner of constructing the electrode assembly can be applied to other forms of electronic components in which custom point-to-point circuit traces need to be affixed to a gauze or textile backing, as well as backings made from other materials. The circuit traces are replaced by the interlaced or sewn flexile wires, and the ends of each flexile wire are terminated, as appropriate to the application. The flexile wires may, by example, connect two circuit boards, or connect to an electrical terminal, power source, or electrical component. In addition, flexile wires may be used to replace a printed circuit board entirely, with each flexile wire serving as a form of sewn interconnect between two or more discrete components, including resistors, capacitors, transistors, diodes, operational amplifiers (op amps) and other integrated circuits, and other electronic or electromechanical components.

[0070] By way of illustration, the flexile wires will be described as terminated for use in an electrode assembly, specifically, as terminated on one end to form an electrode signal pickup and on the other end to connect into a circuit board. Constructing the electrode assembly entails interlacing, including manually threading, or machine sewing the flexile, conductive wire through the flexible backing 20. FIG. 16 is a flow diagram showing a method 90 for constructing a stress-pliant physiological electrode assembly in accordance with a further embodiment. The method can be performed by a set of industrial machines, including a gauze cutting machine to cut the flexible backing 20 to form; a hole punch to cut a plurality of holes provided at regularly-spaced intervals; a stitching or sewing machine to interleave or sew the flexile wire through the flexible backing 20; a wire stripper or plasma jet to remove insulation from the flexile wire, when applicable; and a glue or adhesive dispenser to embed or coat electrode signal pickup in hydrocolloid gel or equivalent non-irritating adhesive. Other forms or combinations of industrial machines, including a single purpose-built industrial machine, could be used.

[0071] As an initial step, a backing is cut to shape and, if required, holes are cut at regularly-spaced intervals along an axial path (step 91) through which the flexile wire will be interlaced. Holes will need to be cut, for instance, if the flexile wire is to be hand-guided through the backing, or where the backing is cut from a material that is difficult to puncture with a threaded needle, such as used by a sewing machine. In one embodiment, the backing is cut from wearable gauze, latex, woven textile, or similar wrap knit or stretchable and wear-safe material, such as a Tricot-type linen; the resulting backing is flexible and yielding. The backing is also cut into an elongated “hourglass”-like shape, when viewed from above, with a pair of cut-outs and a longitudinal midsection that together help minimize interference with and discomfort to breast tissue, particularly in women (and gynecomastia men), such as described supra with reference to FIG. 3. The backing can be cut into other shapes as appropriate to need. In addition, depending upon the application, other materials could be substituted for the backing. For example, neoprene, such as used in wetsuits, could be used where a high degree of elasticity and ruggedness is desired.

[0072] The flexile wire is then interlaced or sewn into the backing (step 92). Interlacing can be performed by a machine that guides the flexile wire through the holes previously cut in the material in a crisscrossed, interwoven, or knitted fashion, as well as by hand. The flexile wire can also be guided through the backing without first cutting holes, provided that the weave of the material is sufficiently loose to allow passage of the flexile wire if the flexile wire is otherwise incapable of passing through the backing without the assistance of a needle or other piercing instrument.

[0073] Alternatively, the flexile wire could be sewn into the backing by using the flexile wire as “thread” that is stitched into place using a needle or similar implement. If a single flexile wire is employed, the stitching will be a line of rounded stitches that alternate top and bottom, as described supra; however, if more than one flexile wire is used, or the stitching pattern requires the use of more than one thread, other forms of conventional machine-stitching patterns could be employed, such as a lockstitch.

[0074] Once completed, the interlacing or sewing of the flexile wire into the backing creates an integrated point-to-

point electrical path that takes the place of a custom circuit trace using an additive, rather than subtractive, manufacturing process. The flexile wire can be interlaced or sewn along a straight, curved, or arbitrary path. One flexile wire is required per point-to-point circuit trace. The strength and pliability of the flexile wire reinforces the backing and, in the still further embodiment described supra beginning with reference to FIG. 9, facilitates extension, compression, bending, and twisting of the narrow longitudinal midsection 22 in response to tensile, compressional, bending, and torsional forces. Thus, the path of the flexile wire along the backing can be mapped to take advantage of the strength and reinforcing properties of the flexile wire, which, when interlaced or sewn into the backing, help the backing counter the stresses to which the backing will be subjected when deployed.

[0075] The flexile wire itself may be insulated or bare (step 93). When one end of the flexile wire is connected to (or forms) an electrode, particularly a dermal physiology electrode that senses electrical potentials on the skin's surface, insulated flexile wire will ordinarily be used, with only a portion of the flexile wire incident to the electrode stripped of insulation. However, bare uninsulated flexile wire could alternatively be used throughout, so long as those portions of the uninsulated flexile wire that are exposed on the contact-facing surface of the backing are insulated and shielded from electrical contact (step 94), such as by applying a layer of plastic, rubber-like polymers, or varnish, or by an additional layer of gauze or adhesive (or non-adhesive) gel over the exposed wire. The uninsulated flexile wire exposed on other surfaces of the backing could also be insulated or simply be left bare.

[0076] One end of the flexile wire may be terminated as an electrode signal pickup (step 95). If insulated flexile wire is used, a portion of the end of the flexile wire is stripped of insulation (step 96) using, for instance, a wire stripper or plasma jet. The electrode signal pickup could either be formed by interlacing (or sewing) the flexile wire (step 97) into the backing in the shape of the desired electrode (step 98) or positioned over the contact-facing area of the backing designated to serve as an electrode signal pickup and embedded within an electrically conductive adhesive (step 99). In a yet further embodiment, the flexile wire could be terminated as a connection to a discrete electrode, such as by sewing an uninsulated portion of the end of the electrode wire into the discrete electrode to thereby establish an electrical contact and affix the discrete electrode to the backing. The Universal ECG EKG electrode, manufactured by Bio Protech Inc., Tustin, Calif., is one example of a discrete electrode.

[0077] Finally, the other end of the flexile wire may be terminated as a connection to a circuit board (step 100). The flexile wire can be interlaced or sewn onto the circuit board, for instance, by back stitching the flexile wire back and forth across the edge of the circuit board to thereby establish an electrical contact and affix the discrete electrode to the backing.

[0078] In a further embodiment, flexile wire can be used to replace all or part of a printed circuit board, such as battery printed circuit board 62 used in constructing a stress-pliant physiological electrode assembly, as described supra, or for any other application that requires interconnection of electrical or electro mechanical components on a physical substrate or backing. Flexile wire in place of

conductive circuit traces can work especially well with simple circuit board layouts, where ample space between components and relatively uncomplicated layouts are amenable to stitched-in interconnections. In addition, the use of flexile wire can simplify circuit layout design in multilayer circuits, as insulated flexile wires can be run across each other in situations that would otherwise require the use of a multilayer printed circuit board or similar solution.

[0079] Through such use of flexile wire, a printed circuit board can be omitted in whole or in part. Interconnects between and connections to the electronic and electro mechanical components formerly placed on the printed circuit board can instead be sewn from flexile wire. For instance, the battery printed circuit board 62 can be replaced by flexile wire interconnects that connect the electrodes to a sewn set of electrical pads formed by over-stitching the flexile wire into electrical contact surfaces of sufficient size to interface with a monitor recorder 14 when fitted into the non-conductive receptacle 25. Likewise, the spring 65 and clasp 66 can be sewn in place using flexile wire to hold a battery in place with flexile wire interconnects connecting the battery to a sewn set of electrical pads formed by over-stitching the flexile wire into electrical contact surfaces of sufficient size to interface with a monitor recorder 14 when fitted into the non-conductive receptacle 25. Still other approaches to replacing printed circuit boards with flexile wire interconnects are possible.

[0080] The resultant stress-pliant physiological electrode assembly may be electrically coupled to a broad range of physiological monitors not limited to electrocardiographic measurement. The foregoing method of constructing a stress-pliant electrode assembly is adaptable to manufacturing other forms of dermal electrodes, including electrodes for electrocardiography, electroencephalography, and skin conductance measurements. Further, by adjusting the number of electrodes, the distances among the electrode signal pickups, and the thickness of the flexile wire, the method can be adapted to manufacturing at low cost an electrode assembly that is lightweight and resistant to tensile, compressional and torsional forces, thus contributing to long-term wear and versatility.

[0081] The extended wear electrocardiography monitor, described supra with reference to FIGS. 1-16, is generally worn as a patch adhered to the skin during use. Some patients, however, may not be able to wear an adhesive patch due to allergic reaction, skin condition, or other factors that make the wearing of an adhesive patch, even for a short duration, either undesirable or impracticable. Moreover, athletes, particularly when interested in monitoring performance during training and sports activities, may find the wearing of an adhesive patch a hindrance to movement and at odds with performance monitoring.

[0082] As an alternative to an adhesively-attached electrode patch, the electrodes of the extended wear electrocardiography monitor can be integrated into a wearable garment that can be coupled with a monitor recorder 14 (shown in FIG. 1) or similar recording device. FIG. 17 is a front view of a wearable electrocardiography and physiology monitoring ensemble 300 in accordance with a further embodiment. The wearable monitoring ensemble 300 is provided through a wearable garment 301, such as a shirt, blouse, or tunic, that is worn about the upper region of the torso that is equipped with an electrode assembly 313. The wearable garment 301 is constructed, at least in part, using

a compressible and elastomeric material, such as Spandex, formerly manufactured by E.I. du Pont de Nemours and Company (“DuPont”), Wilmington, Del.; Lycra, manufactured by Koch Industries, Inc., Wichita, Kans.; or elastane. Other types or combinations of compressible and elastomeric materials are possible.

**[0083]** An electrode patch achieves fully continuous electrode contact through an adhesive or a fixing agent that adheres a gauze or similarly-woven or flexible material against the skin; the gauze serves as a backing to each electrode, which is held captive and firmly in place between the skin and the gauze. In addition, the electrodes themselves could be coated with an adhesive to self-adhere to the electrodes directly to the skin. In both forms, the presence of adhesive on the skin’s surface can be at variance with extended long-term wear, especially on patients with sensitive or fragile skin or who have allergies or sensitivities to the chemicals or materials used in adhesive patches.

**[0084]** The construction of the wearable garment **301** employs an internal structure **302** that obviates the need to use adhesives or other fixing agents to hold electrophysiology and physiology sensing electrodes into place. The internal structure **302** allows the wearable garment **301** to exert a compressive force against an electrode assembly **313** that is sufficient to keep the electrodes **309** and **310** in useably-continuous contact with the wearer’s skin throughout the monitoring period. The electrode assembly **313** contains at least two electrodes **309** and **310** that are both affixed to a backing, either individually or combined. The electrode assembly **313** is provided on an inside-facing surface of the wearable garment **301** on an underside of the internal structure **302** to keep the electrode assembly **313** firmly against the wearer’s skin. In contrast to an electrode-equipped adhesive patch, the wearable garment **301** permits unconstrained free movement during monitoring and the wearer is typically unaware of the presence of the electrode assembly **313**. However, to effectively measure electrophysiology, the electrodes **309** and **310** need to be kept in fairly continuous, albeit not absolutely constant, physical contact with the skin.

**[0085]** The wearable monitoring ensemble **300** obviates the necessity of adhesives or other fixing agents that adhere directly to the skin by utilizing the internal structure **302** of the wearable garment **301** to place and retain the electrode assembly **313** securely against the skin. To some degree, internal structure **302** inherent in the overall design of the wearable garment **301**, when in the form of clothing worn about the torso, specifically, a shirt, blouse, or tunic, will retain the relative positions of the various panels that make up the wearable garment **301** in place during wear. Elements of the inherent garment design include, for instance, the openings for the arms **303a** and **303b**, the neck **304**, and torso **305** proper. Other elements of inherent garment design are possible.

**[0086]** To facilitate monitoring purposes, though, the relative position of the panel upon which the sensory assembly **313** is affixed to the internal structure **302** on the inside surface of the wearable garment **301** must be kept from dramatically shifting about; the location of the electrode assembly **313** ought to be sufficiently stable, so as to avoid displacing the underlying electrodes **309** and **310** to the degree that cardiac electric potential signals are degraded or change character.

**[0087]** The inherent design of the wearable garment **301** only provides a partial solution and these structures alone will not suffice to maintain the electrode assembly **313** in fairly continuous physical contact with the skin. The internal structure **302** of the wearable garment **301** is biased to press snugly against the skin in at least those portions of the wearable garment **301** where the electrode assembly **313** need be held in a relatively stable orientation. The compressive bias is provided by the compressible and elastomeric material and the internal structure **302**, which can include elastic bands **306a**, **306b**, **306c**, and **306d**, embedded longitudinally across the chest, or by a combination of fabric components with varying characteristics of elasticity.

**[0088]** The compressive force imparted by the wearable garment **301** on the electrode assembly **313** is provided by placing the electrode assembly **313** on an inside surface of the wearable garment **301** on an underside of the internal structure **302**, such that the electrode assembly **313** is firmly “pinned” in place against the skin, yet not adhered. The amount of side-to-side shift or momentary loss of contact that can be tolerated without signal degradation or compromise depends upon the monitoring location. For instance, to optimize capture of P-wave signals, the electrode assembly **313** can advantageously be positioned axially along the midline of a wearer’s sternum, such as described in commonly-assigned U.S. Pat. No. 9,700,227, the disclosure of which is incorporated by reference. To secure the electrode assembly **313** in the desired orientation axially along the sternal midline, the wearable garment **301** integrates a bias that imparts compressive force circumferentially about the wearer’s torso; the compressive force is sufficient to keep the two electrodes **309** and **310** against the skin for the majority of the time during wear and monitoring. However, whereas an electrode patch seeks to keep the electrodes in continuous and stationary contact with the skin at all times, the electrodes here are permitted to actively “float” over the skin’s surface, so long as at least a part of an electrode’s surface contacts the skin. Thus, to a limited extent, the electrodes **309** and **310** can slide around the general region on the skin where a cardiac electric potential signal sensing is desired. In addition, the occasional loss of signal pick up that can occur if the electrode assembly **313** briefly loses contact with the skin, such as happens if the wearer makes a sudden movement, can be weathered; cardiac electric potential signals lost through a momentary loss of skin contact are not likely to adversely degrade overall signal fidelity, so long as the loss of contact is sufficiently brief and spans say, no more than a few heartbeats. As a result, the wearable garment **301** needs to keep the electrode assembly **313** oriented on the skin in the same overall spot, but the electrode assembly **313** need not be fixed as an absolutely stationary location and some degree of sliding movement or “float” along the skin’s surface is permissible.

**[0089]** The electrode assembly **313** is also provided with two electrical connections **311** and **312** through which a monitor recorder can receive and record electrical potential signals. One end of each of the electrical connections **311** and **312** is connected to one of the electrodes **309** and **310**, while the other end of each of the electrical connections **311** and **312** is terminated to suit interfacing with a compatible form of monitor recorder. In one embodiment, the electrical connections **311** and **312** can be connected to the pair of electrical pads **34** provided on the non-conductive receptacle **25** (shown in FIG. 4) to electrically couple the electrodes

**309** and **310** to a reusable monitor recorder **14**. In a further embodiment, the electrical connections can be adapted to wirelessly interface to a wireless-capable monitor recorder. Each of the electrical connections **311** and **312** are interfaced to a wireless transceiver over which the cardiac electric potential signals sensed by the electrodes **309** and **310** are transmitted. Other forms of terminating the electrical connections **311** and **312** to interface to a monitor recorder are possible.

[0090] The electrode assembly **313** can be packaged in at least three different forms, including a flexible circuit electrode assembly and flexile wire electrode assemblies with discrete or sewn-in electrodes. These forms of sensor assemblies will now be discussed. First, FIG. **18** is a contact-surface view of a flexible circuit electrode assembly **313** of the wearable monitoring ensemble **300** of FIG. **17**. The electrode assembly **313** contains two electrodes **309** and **310**, which are formed on two flexible circuits **314** and **315**, respectively. In a further embodiment, the two electrodes **309** and **310** can be formed on a single flexible circuit. The flexile circuits include circuit traces **311** and **312** that terminate respectively with electrical pads **316** and **317** for mating with, for instance, the pair of electrical pads **34** provided on the non-conductive receptacle **25**.

[0091] Second, the two flexible circuits **314** and **315** can be replaced with a pair of flexile wires that are sewn or stitched into a pair of discrete electrodes, such as described supra with reference to FIGS. **9** through **15A-C**. FIG. **19** is a contact-surface view of a flexile wire interconnect **320** of the wearable monitoring ensemble **300** of FIG. **17**. The two electrodes **309** and **310** are stitched or sewn **323** and **324** into the compressible and elastomeric material (not shown) using a pair of flexile wires **321** and **322**. The insulation is first stripped from the ends of the pair of flexile wires **321** and **322** and an electrical connection is established between the two electrodes **309** and **310** and the pair of flexile wires **321** and **322**. In similar fashion, the pair of flexile wires **321** and **322** can be electrically connected on their opposite ends to additional components **325** and **326**, such as the non-conductive receptacle **25**, electrical terminals, or a wireless transceiver, by stripping insulation from and sewing or stitching **327** and **328** the other ends of the flexile wires **321** and **322** into the additional components **325** and **326**. Other ways of interconnecting electrodes and additional components using flexile wire, including soldering and crimping, are possible.

[0092] Finally, both the two flexible circuits **314** and **315** and the two electrodes **309** and **310** can be respectively replaced with a pair of flexile wires and a pair of sewn-in electrodes. FIG. **20** is a contact-surface view of a flexile wire electrode and interconnect **330** of the wearable monitoring ensemble **300** of FIG. **17**. A pair of electrodes **323** and **324** are stitched or sewn into the compressible and elastomeric material (not shown) using a pair of flexile wires **321** and **322**. The pair of flexile wires **321** and **322** can be electrically connected on their opposite ends to additional components **325** and **326**, such as the non-conductive receptacle **25**, electrical terminals or a wireless transceiver, by stripping insulation from and sewing or stitching **327** and **328** the other ends of the flexile wires **321** and **322** into the additional components **325** and **326**. Other ways of interconnecting electrodes and additional components using flexile wire, including soldering and crimping, are possible.

[0093] The wearable monitoring ensemble **300** is advantageous for both patients and athletes because the ambulatory apparatus can collect high-quality ECG and physiological data while the wearer engages in activities of daily living. ECG data are crucial for diagnosing many cardiovascular conditions, but additional data are often necessary for differential diagnoses, such as in diabetic and hypertensive patients. Cardiovascular patients must take particular care in monitoring their status to avoid related adverse events; for example, monitoring temperature can be helpful in cardiovascular patients because cardiovascular system compromises patients' capacity for maintaining a normal body temperature, and cardiovascular patients may be more susceptible to hypothermia in cool environments.

[0094] Athletes also benefit from ECG data combined with additional physiological data to prevent adverse cardiac events, including power sports athletes, aged athletes, and young athletes with congenital heart conditions. Moreover, ECG data combined with other physiological data may aid athletes in optimizing performance. In many instances, blood sugar measurements may aid in generating a diagnosis, prognosis, and treatment plan as well as predicting athletic performance. For example, patients with diabetes or blood sugar levels that are greater than normal are also more likely to develop certain heart diseases, such as ischemic heart disease and myocardial infarction. Moreover, multiple types of physiological data may be combined to predict additional disease conditions, such as the combination of high blood pressure, coronary heart disease, and diabetes, which can severely damage cardiac muscle and lead to heart failure. In addition, blood sugar plays a strong role in athletic performance and recovery; thus, athletes benefit from both monitoring their blood sugar before, during, and after exercise as well as using the monitoring data to elucidate undiagnosed blood sugar conditions. For example, exercise-induced hypoglycemia can severely hamper performance and may indicate a more serious condition that can lead to sudden death.

[0095] Monitoring blood pressure may also be key to elucidating a patient's or athlete's underlying physical condition. Hypertension is the greatest risk factor for cardiovascular disease in both normal and athlete populations. Dubbed the "silent killer," hypertension is both common as well as under-diagnosed and can damage various organs, leading to a higher risk of left ventricular hypertrophy and sudden death, among other conditions. Further, combined with ECG data, it may provide critical data for determining a patient's cardiovascular condition. For example, as noted above, heart failure is more likely in patients with high blood pressure combined with heart disease and blood sugar dysregulation. Further, silent ischemia is often diagnosed through detecting hypertension and ST depression, which is best observed using an ambulatory ECG device; a combined prolonged QT interval and hypertension are associated with increased risk of pathological cardiovascular conditions, including the risk of sudden death; and hypertensive patients with abnormal T wave patterns exhibit increased left ventricular mass, which enhances the risk of adverse cardiac events, including sudden death. Moreover, while the athletic population maintains a lower blood pressure generally, hypertension remains the greatest cardiac risk factor for athletes. Further, athletes benefit from blood pressure monitoring, particularly during exercise, because untreated

hypertension can significantly impair athletic performance; moreover, older athletes are at particular risk for undiagnosed hypertension.

[0096] Further, detecting abnormal respiratory function may facilitate diagnosis, prognosis, and treatment of certain disorders in both patients and athletes. For example, Cheyne-Stokes breathing associated with chronic heart failure is a predictor of poor prognoses associated with cardiac death. In addition, cardiorespiratory conditions are common in athletes but are often undiagnosed. Such conditions not only impair performance, but overtraining with a cardiorespiratory may lead to severe consequences, such as sudden death due to severe bronchoconstriction. Further, sleep decreases the diagnostic efficacy of ECG monitoring alone due to natural heart rate decrease during sleep. As a patient enters non-rapid eye movement (NREM) sleep, the patient undergoes physiological changes due to less sympathetic nervous system activity. Thus, even healthy people may experience sinus bradyarrhythmia during sleep, and ECG monitoring alone may reveal whether the bradyarrhythmia is natural or due to a pathological condition, such as an apnea. Further, if a patient experiences other types of arrhythmias during sleep, a physician may not be able to determine whether an arrhythmia is due to sleep apnea or other morbidity without measuring the patient's air flow, which is the flow of air in and out of the patient's lungs during breathing, or other respiration indicator. However, considering that cardiac manifestations of sleep apnea are most apparent at night, short-term ECG monitoring during business hours may not reveal cardiac arrhythmia.

[0097] While the invention has been particularly shown and described as referenced to the embodiments thereof, those skilled in the art will understand that the foregoing and other changes in form and detail may be made therein without departing from the spirit and scope.

What is claimed is:

1. A wearable electrocardiography monitoring ensemble, comprising:

a first receptacle defined by two horizontal bands across a wearable garment;

a second receptacle defined by two further horizontal bands across the wearable garment and positioned under the first receptacle;

a first electrode assembly positioned within the first receptacle and comprising a backing with an electrical connection having an electrode on one end of the electrical connection and terminating the other end of the electrical connection to connect with a monitor recorder;

a second electrode assembly positioned within the second receptacle and comprising a backing with an electrical connection having an electrode on one end of the electrical connection and terminating the other end of the electrical connection to connect with a further monitor recorder, wherein the first and second electrodes are aligned longitudinally in the wearable garment.

2. A wearable electrocardiography monitoring ensemble according to claim 1, further comprising:

a wireless transceiver on the terminated end of the electrical connection of the first and second electrode assemblies to wirelessly connect with the monitor recorder and the further monitor recorder respectively.

3. A wearable electrocardiography monitoring ensemble according to claim 1, further comprising:

one or more electrical pads on the terminated end of the electrical connection of the first and second electrode assemblies to connect with the monitor recorder and the further monitor recorder respectively.

4. A wearable electrocardiography monitoring ensemble according to claim 3, wherein each of the monitor recorder and the further monitor recorder comprises electrical pads for mating with the electrical pads of the first and second electrode assemblies respectively.

5. A wearable electrocardiography monitoring ensemble according to claim 1, wherein each of the electrodes are formed on a flexible circuit.

6. A wearable electrocardiography monitoring ensemble according to claim 1, wherein each of the monitor recorder and the further monitor recorder comprise a housing with electronic circuitry for recording and storing ECG data.

7. A wearable electrocardiography monitoring ensemble according to claim 1, further comprising:

a non-conductive receptacle shaped to receive the monitor recorder or the further monitor recorder and positioned on a surface of the backing of one or more of the first and second electrode assemblies respectively.

8. A wearable electrocardiography monitoring ensemble according to claim 7, wherein the monitor recorder and the further monitor recorder are placed in the non-conductive receptacle for the first and second electrode assemblies respectively.

9. A wearable electrocardiography monitoring ensemble according to claim 1, wherein the wearable garment comprises one or more of a shirt, blouse, and tunic.

10. A wearable electrocardiography monitoring ensemble according to claim 1, wherein the first and second receptacles each provide compressive force imparted by the wearable garment on the first and second electrode assemblies respectively.

11. A method for constructing a wearable electrocardiography monitoring ensemble, comprising:

obtaining a wearable garment;

defining a receptacle in a wearable garment via two horizontal bands positioned across the wearable garment, wherein a first electrode assembly is positioned within the first receptacle and comprises a backing with an electrical connection having an electrode on one end of the electrical connection and terminated at the other end of the electrical connection to connect with a monitor recorder; and

defining a second receptacle by two more horizontal bands positioned across the wearable garment under the first receptacle, wherein a second electrode assembly is positioned within the second receptacle and comprises a backing with an electrical connection having an electrode on one end of the electrical connection and terminated at the other end of the electrical connection to connect with a further monitor recorder,

wherein the first and second electrodes are aligned longitudinally in the wearable garment.

12. A method according to claim 11, further comprising: positioning a wireless transceiver on the terminated end of the electrical connection of each of the first and second electrode assemblies to wirelessly connect with the monitor recorder and the further monitor recorder respectively.

**13.** A method according to claim **11**, further comprising: implementing one or more electrical pads on the terminated end of the electrical connection of the first and second electrode assemblies to connect with the monitor recorder and the further monitor recorder respectively.

**14.** A method according to claim **13**, wherein the monitor recorder comprises electrical pads for mating with the electrical pads of the first or second electrode assemblies.

**15.** A method according to claim **11**, wherein each of the electrodes are formed on a flexible circuit.

**16.** A method according to claim **11**, wherein the monitor recorder and the further monitor recorder each comprise a housing comprising electronic circuitry for recording and storing ECG data.

**17.** A method according to claim **11**, further comprising: affixing a non-conductive receptacle shaped to receive the monitor recorder or the further monitor recorder on the backing of one or more of the first and second electrode assemblies respectively.

**18.** A method according to claim **17**, wherein the monitor recorder or the further monitor recorder is placed in the non-conductive receptacle for at least one of the first and second electrode assemblies respectively.

**19.** A method according to claim **11**, wherein the wearable garment comprises one or more of a shirt, blouse, and tunic.

**20.** A method according to claim **11**, wherein the first and second receptacles each provide compressive force imparted by the wearable garment on the first and second electrode assemblies respectively.

\* \* \* \* \*

专利名称(译)	可穿戴式心电图和生理监测系统		
公开(公告)号	<a href="#">US20190231213A1</a>	公开(公告)日	2019-08-01
申请号	US16/378458	申请日	2019-04-08
[标]申请(专利权)人(译)	BARDY诊断		
申请(专利权)人(译)	BARDY诊断, INC.		
当前申请(专利权)人(译)	BARDY诊断, INC.		
[标]发明人	BARDY GUST H HANDFELT MARK BISHAY JON MIKALSON FELIX JASON		
发明人	BARDY, GUST H. HANDFELT, MARK BISHAY, JON MIKALSON FELIX, JASON		
IPC分类号	A61B5/0408 A61B5/00 A61B5/0432		
CPC分类号	A61B5/04085 A61B5/6833 A61B5/6823 A61B5/6804 A61B5/0006 A61B5/0432 A61B2562/222 A61B2562/227 A61B2562/0209 A61B2562/164 A61B2560/0443 A61B2560/0412 A61B2562/0215		
优先权	61/882403 2013-09-25 US		
外部链接	<a href="#">Espacenet</a> <a href="#">USPTO</a>		

摘要(译)

提供了可穿戴心电图监测系统。第一容器通过横跨可穿戴服装放置的两个水平带限定在可穿着服装中。第二容器由两个另外的水平带限定，所述水平带横跨第一容器下方的可穿戴衣服定位。第一电极组件定位在第一插座内并包括具有电连接的背衬，该电连接在电连接的一端具有电极并且终止于电连接的另一端以与监视记录器连接。第二电极组件定位在第二插座内并包括具有电连接的背衬，该电连接在电连接的一端具有电极并且在电连接的另一端终止以与另一个监视记录器连接，其中第一和第二电极组件连接。第二电极在可穿着服装中纵向对齐。

300

