



(19) **United States**

(12) **Patent Application Publication**  
**Schultheis et al.**

(10) **Pub. No.: US 2019/0029753 A1**

(43) **Pub. Date: Jan. 31, 2019**

(54) **METHODS OF REMOVING HEAT FROM AN ELECTRODE USING THERMAL SHUNTING**

*A61B 5/01* (2006.01)  
*A61B 18/00* (2006.01)

(71) Applicant: **EPIX Therapeutics, Inc.**, Santa Clara, CA (US)

(52) **U.S. Cl.**  
CPC .... *A61B 18/1492* (2013.01); *A61B 2218/002* (2013.01); *A61B 5/068* (2013.01); *A61B 5/150954* (2013.01); *A61B 5/6852* (2013.01); *A61B 18/1206* (2013.01); *A61B 5/01* (2013.01); *A61B 2018/00821* (2013.01); *A61B 2018/00815* (2013.01); *A61B 2018/00797* (2013.01); *A61B 2018/00761* (2013.01); *A61B 2018/00714* (2013.01); *A61B 2018/00702* (2013.01); *A61B 2018/00678* (2013.01); *A61B 2018/00642* (2013.01); *A61B 2018/00577* (2013.01); *A61B 2018/00357* (2013.01); *A61B 2018/00351* (2013.01); *A61B 2018/0016* (2013.01); *A61B 2018/00101* (2013.01); *A61B 2018/00083* (2013.01); *A61B 2018/00029* (2013.01); *A61B 2018/00023* (2013.01); *A61B 2018/00839* (2013.01); *A61B 2018/00875* (2013.01); *A61B 2018/128* (2013.01); *A61B 2018/1467* (2013.01); *A61B 2217/007* (2013.01); *A61B 2562/046* (2013.01); *A61B 5/0422* (2013.01)

(72) Inventors: **Eric Andrew Schultheis**, Sunnyvale, CA (US); **Josef Vincent Koblish**, Sunnyvale, CA (US); **Dorin Panescu**, Sunnyvale, CA (US)

(21) Appl. No.: **16/147,403**

(22) Filed: **Sep. 28, 2018**

**Related U.S. Application Data**

(63) Continuation of application No. 15/336,648, filed on Oct. 27, 2016, which is a continuation of application No. 15/214,376, filed on Jul. 19, 2016, now Pat. No. 9,522,037, which is a continuation of application No. PCT/US2015/061419, filed on Nov. 18, 2015.

(60) Provisional application No. 62/081,710, filed on Nov. 19, 2014, provisional application No. 62/094,892, filed on Dec. 19, 2014, provisional application No. 62/135,046, filed on Mar. 18, 2015, provisional application No. 62/135,025, filed on Mar. 18, 2015, provisional application No. 62/138,338, filed on Mar. 25, 2015, provisional application No. 62/211,539, filed on Aug. 28, 2015.

**Publication Classification**

(51) **Int. Cl.**  
*A61B 18/14* (2006.01)  
*A61B 5/042* (2006.01)  
*A61B 5/06* (2006.01)  
*A61B 5/15* (2006.01)  
*A61B 5/00* (2006.01)  
*A61B 18/12* (2006.01)

(57) **ABSTRACT**

According to some embodiments, a medical instrument (for example, an ablation device) comprises an elongate body having a proximal end and a distal end, an energy delivery member positioned at the distal end of the elongate body, a first plurality of temperature-measurement devices carried by or positioned within the energy delivery member, the first plurality of temperature-measurement devices being thermally insulated from the energy delivery member, and a second plurality of temperature-measurement devices positioned proximal to a proximal end of the energy delivery member, the second plurality of temperature-measurement devices being thermally insulated from the energy delivery member.

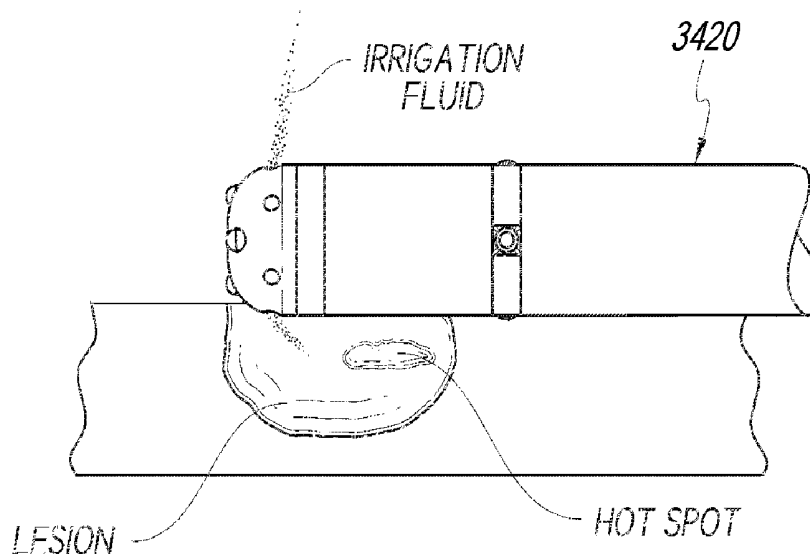

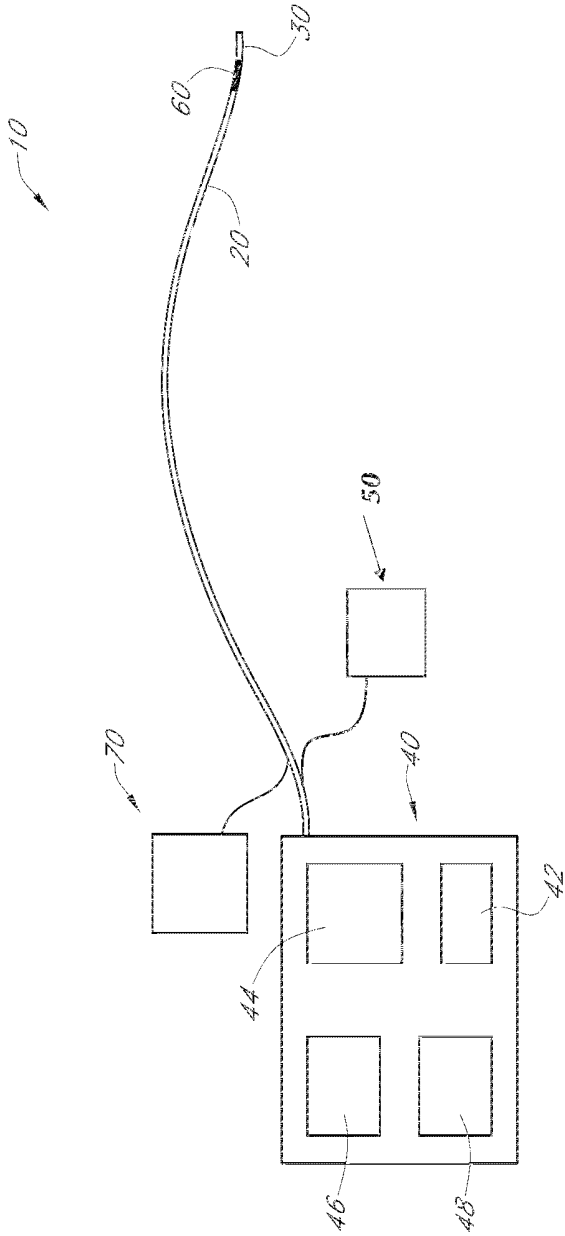

FIG. 1

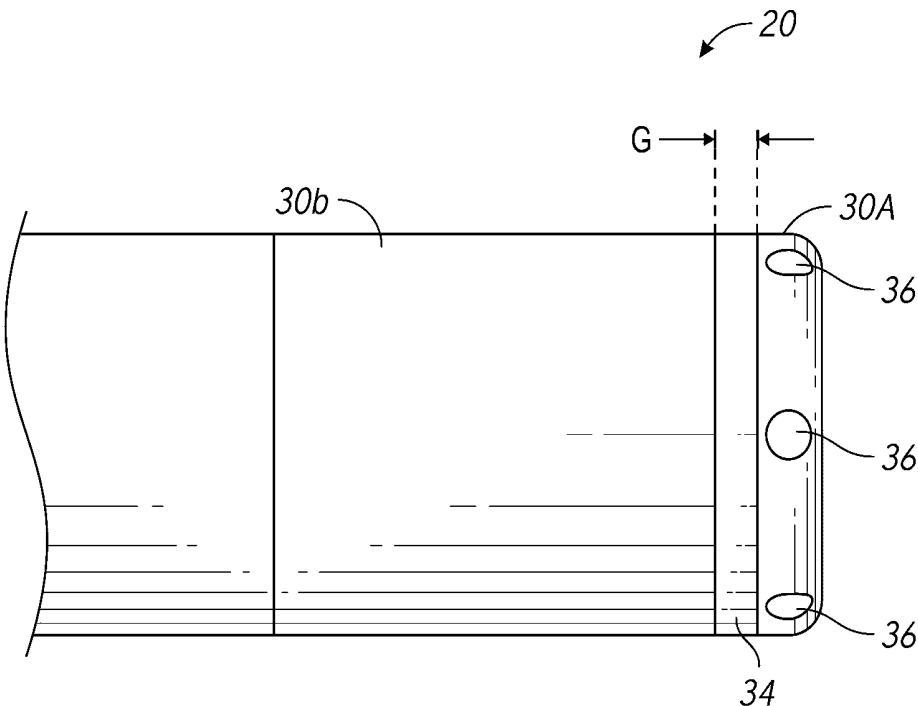

FIG. 2

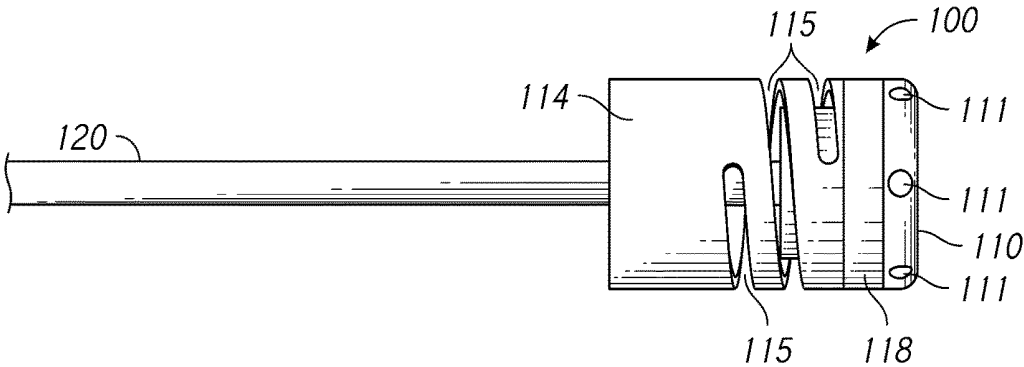

FIG. 3

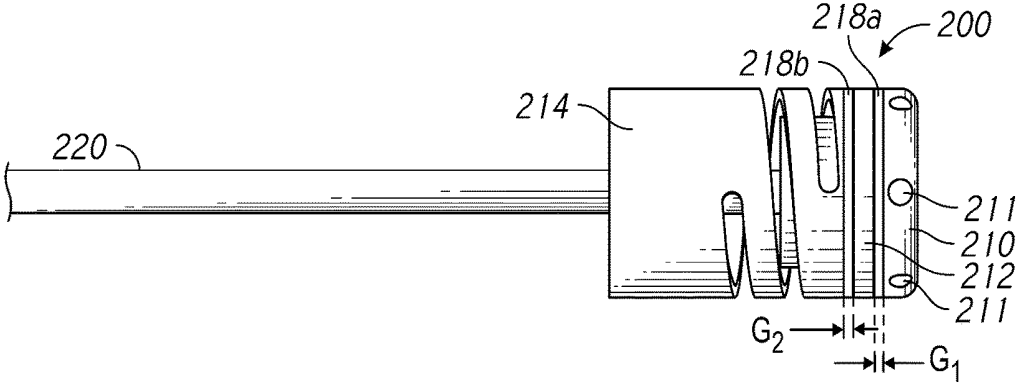

FIG. 4

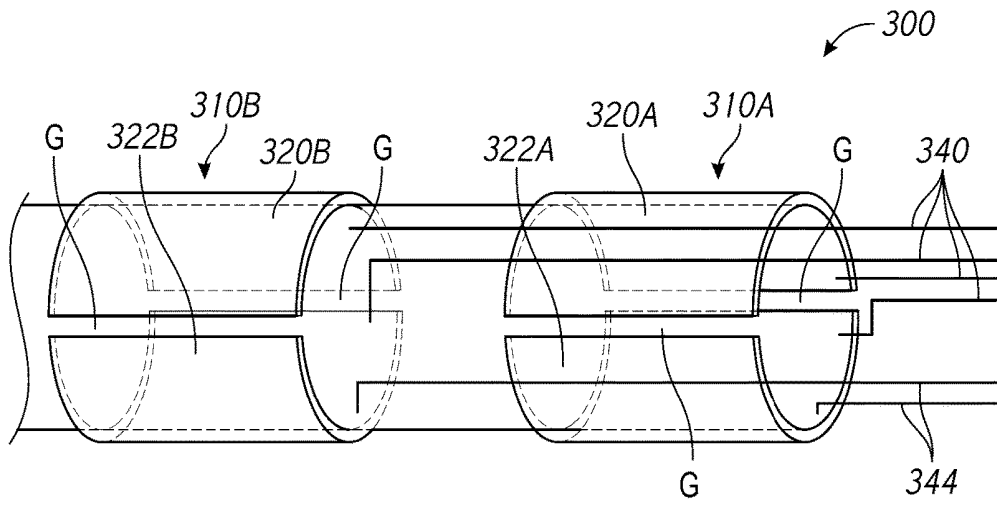

FIG. 5

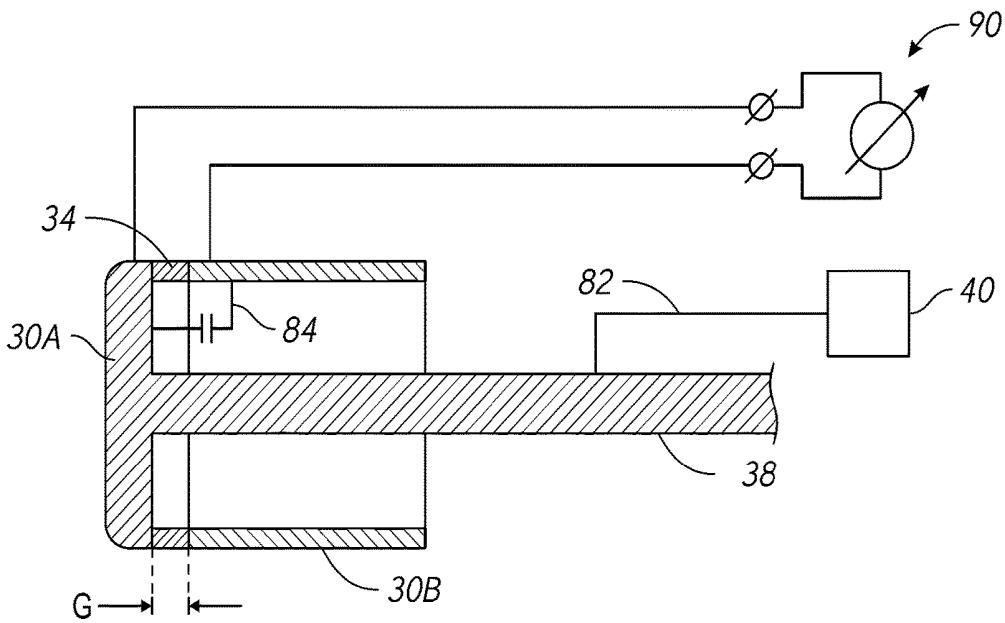

FIG. 6

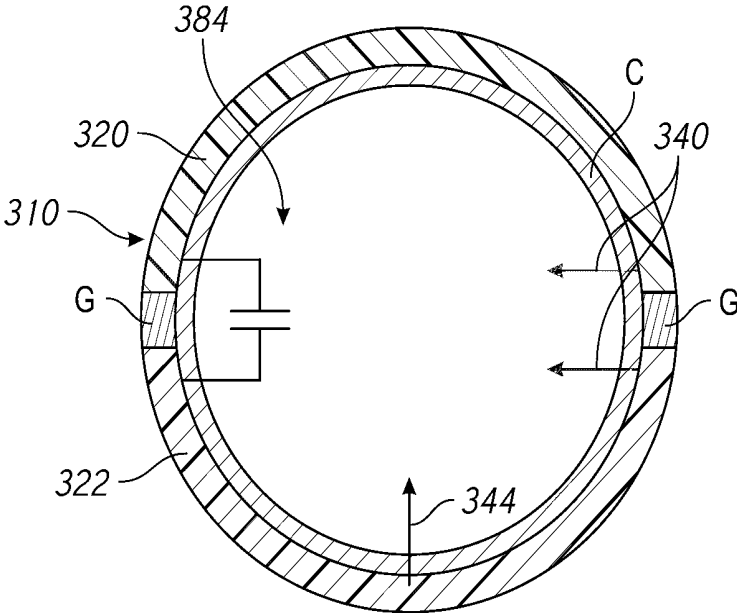

FIG. 7

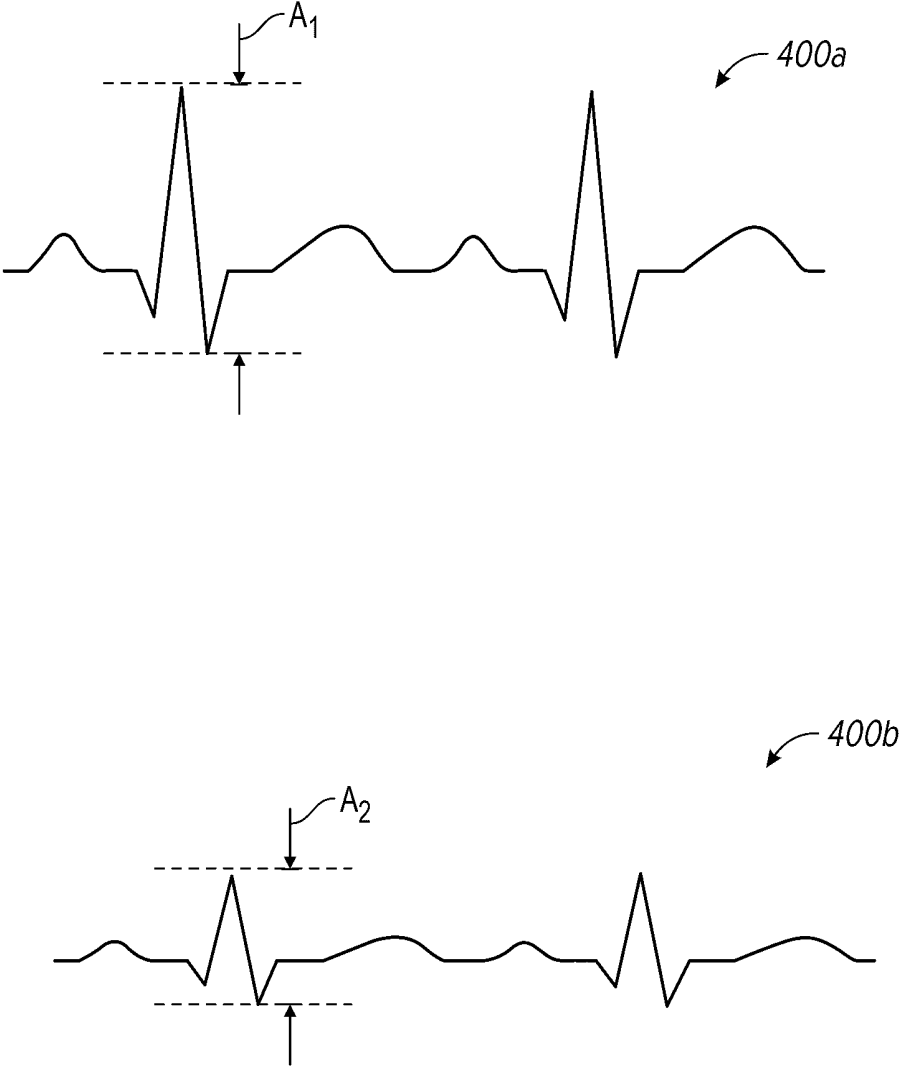

FIG. 8

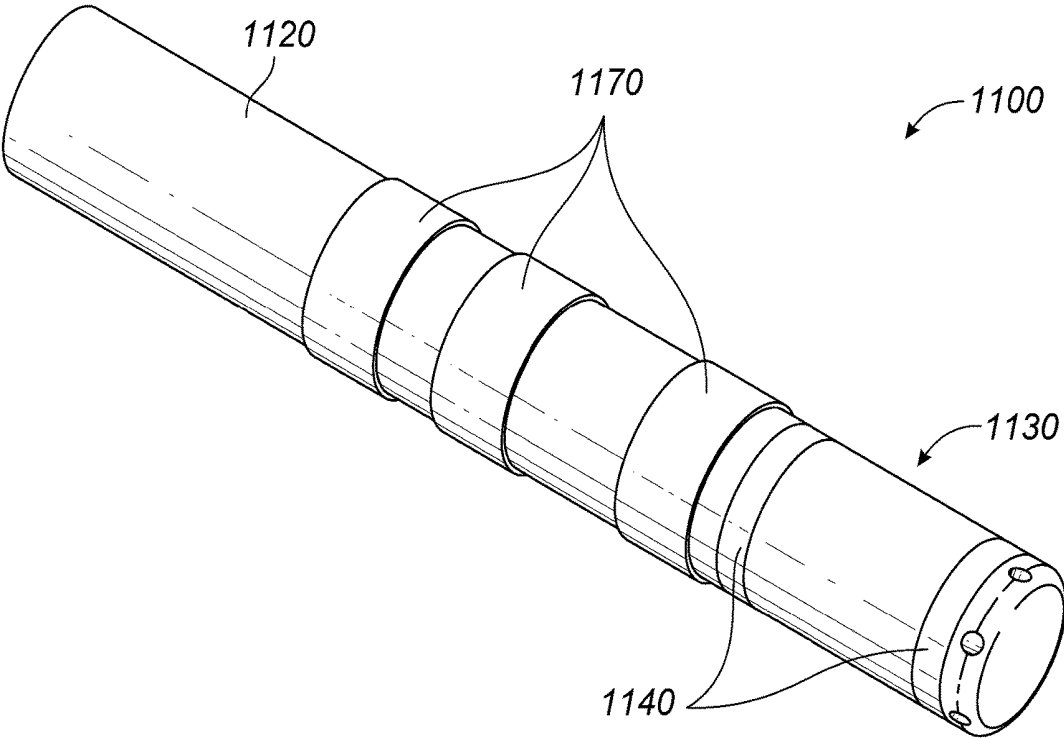

FIG. 9

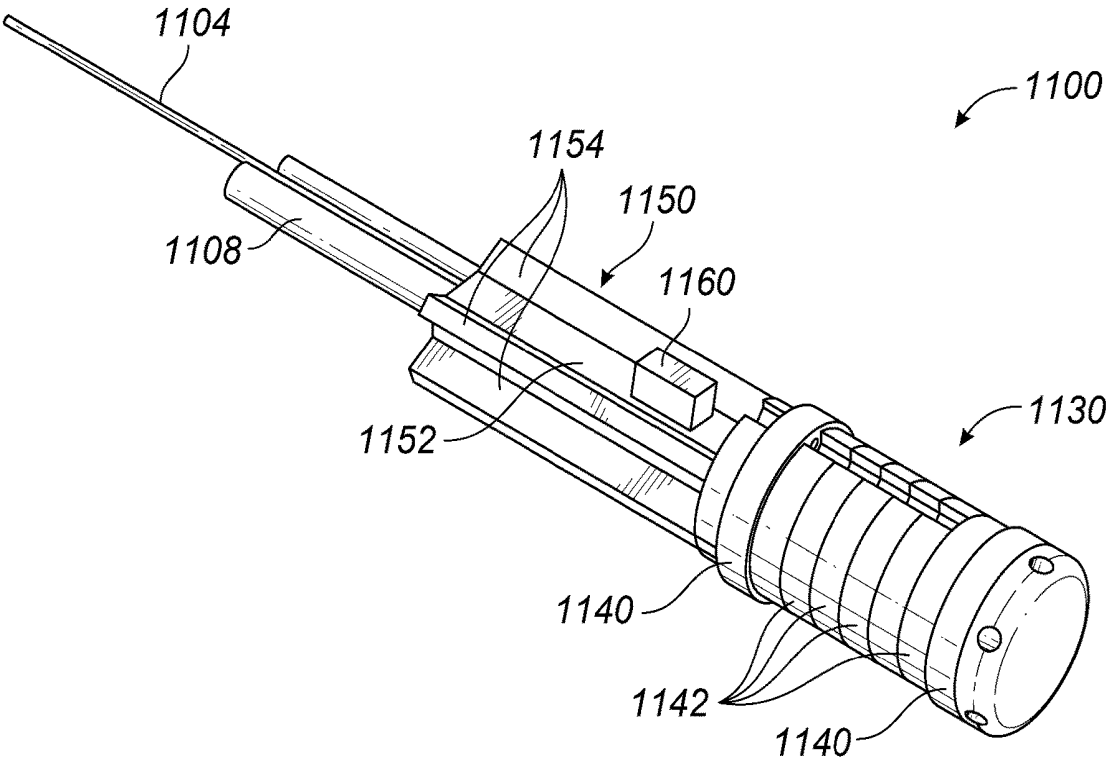

FIG. 10

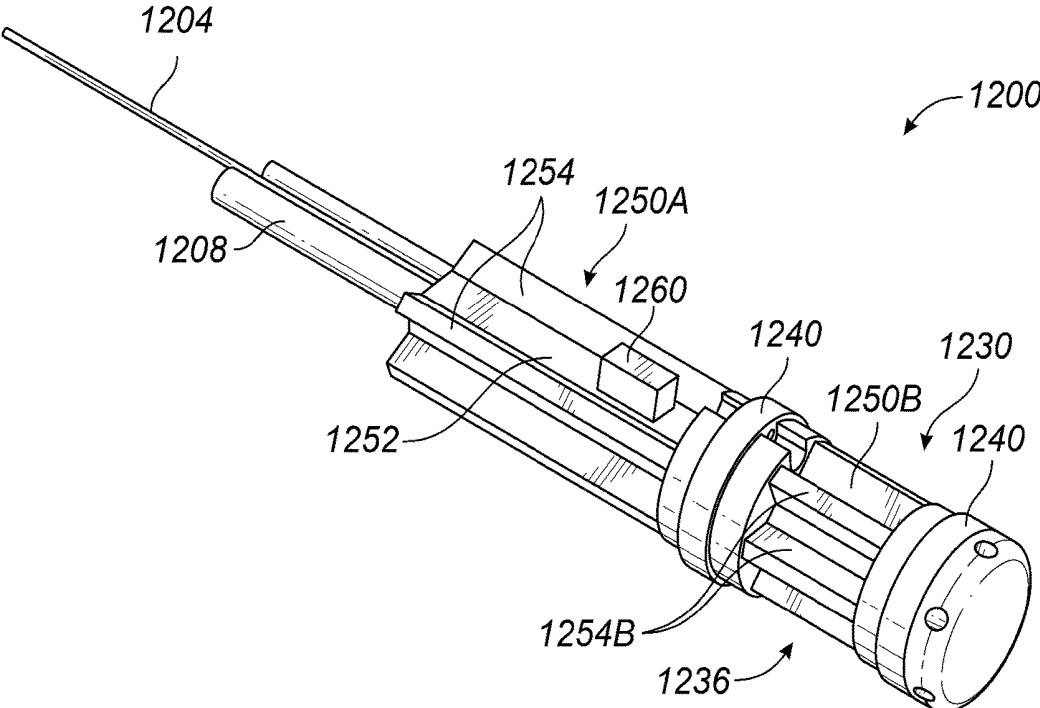

FIG. 11

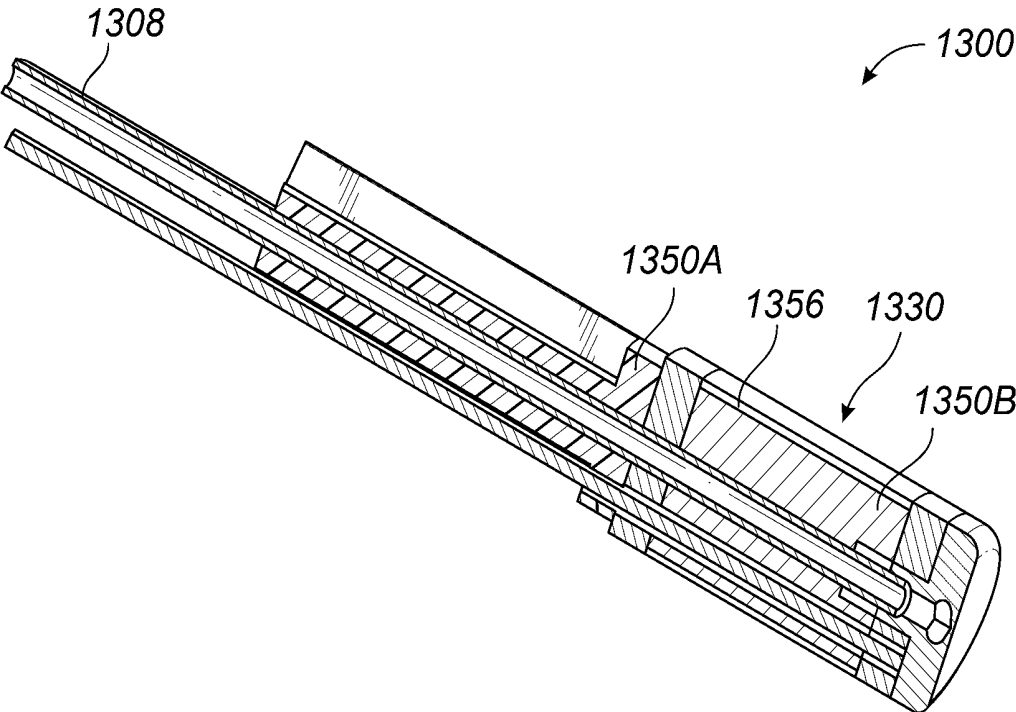

FIG. 12

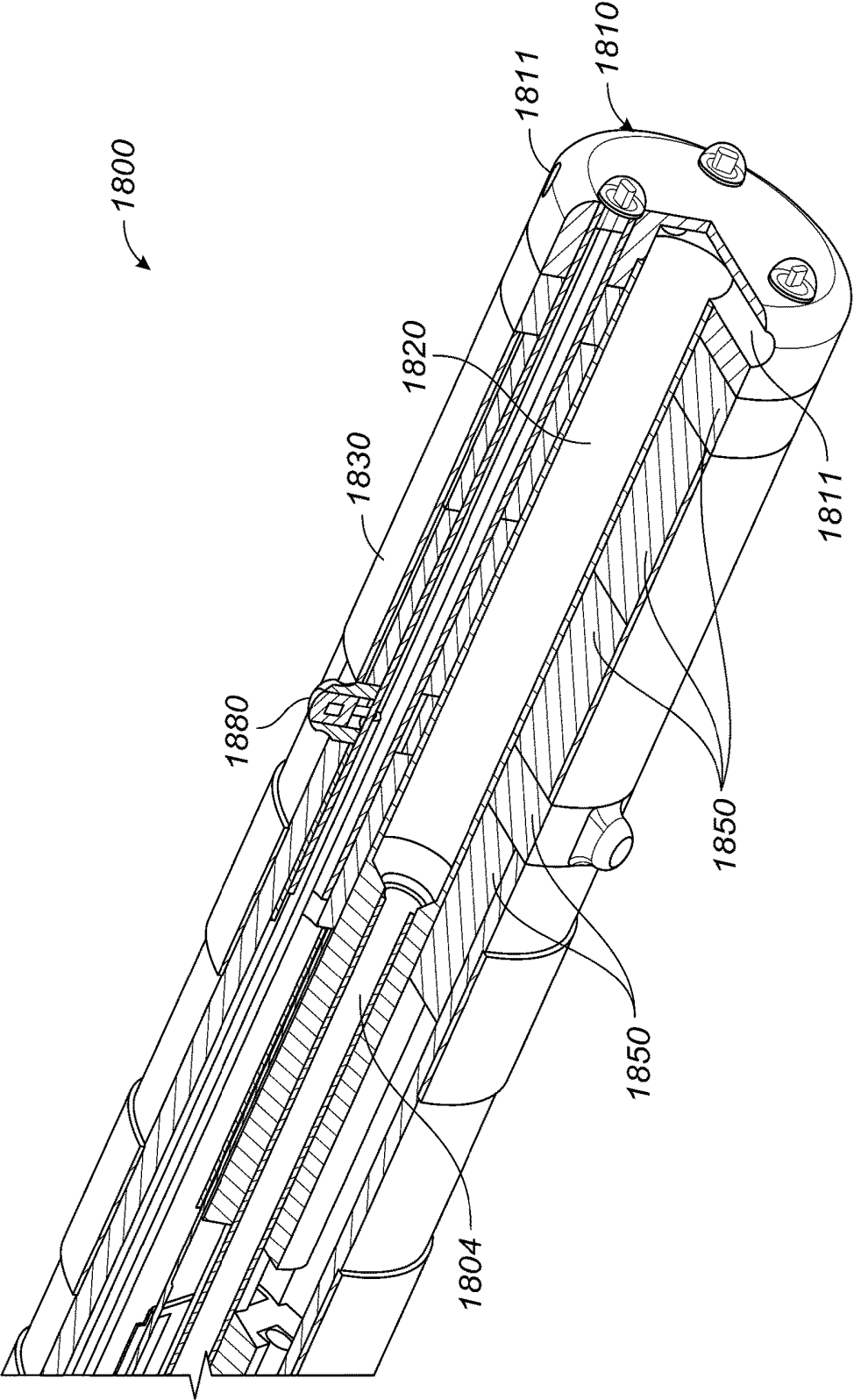

FIG.13

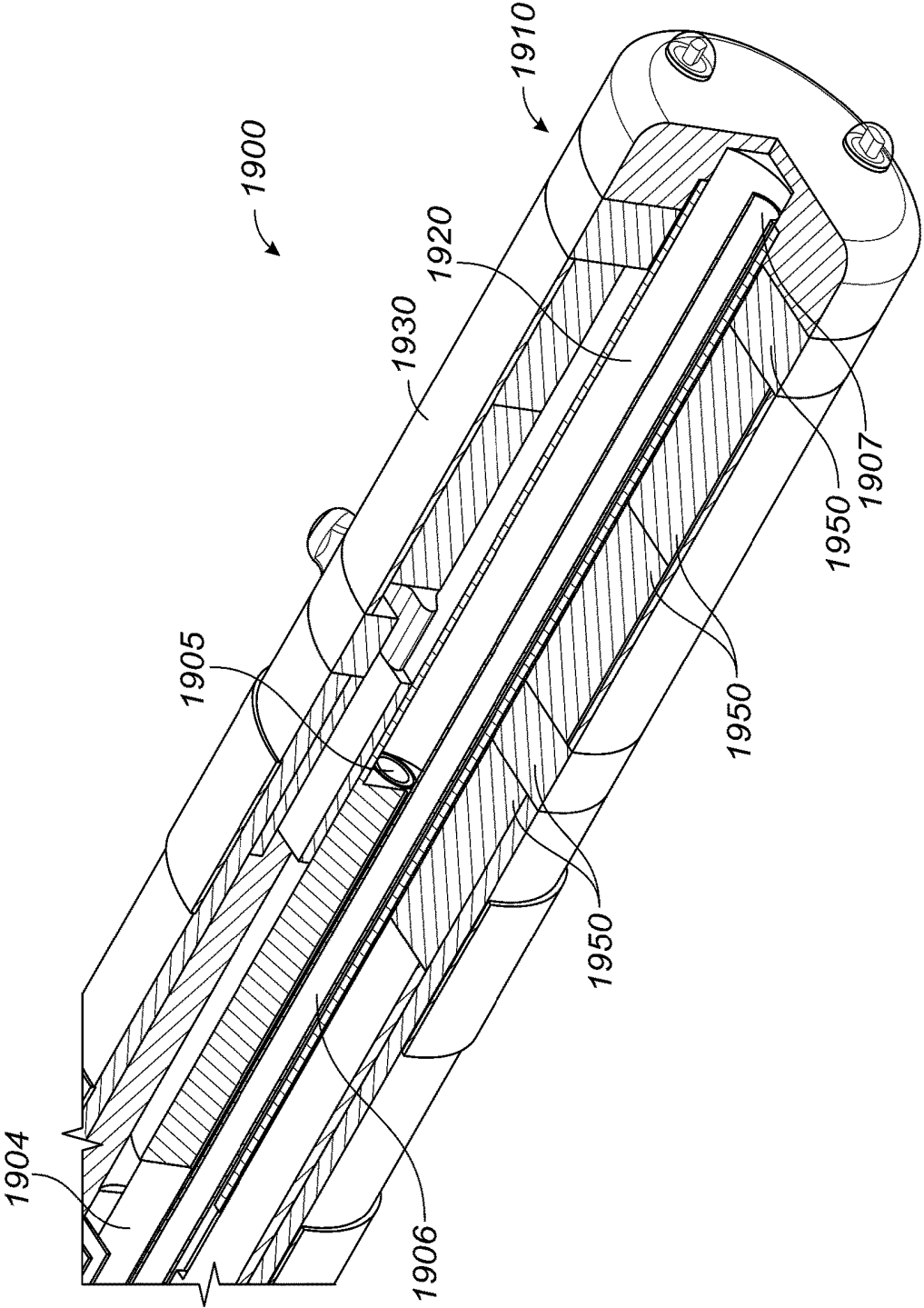

FIG. 14

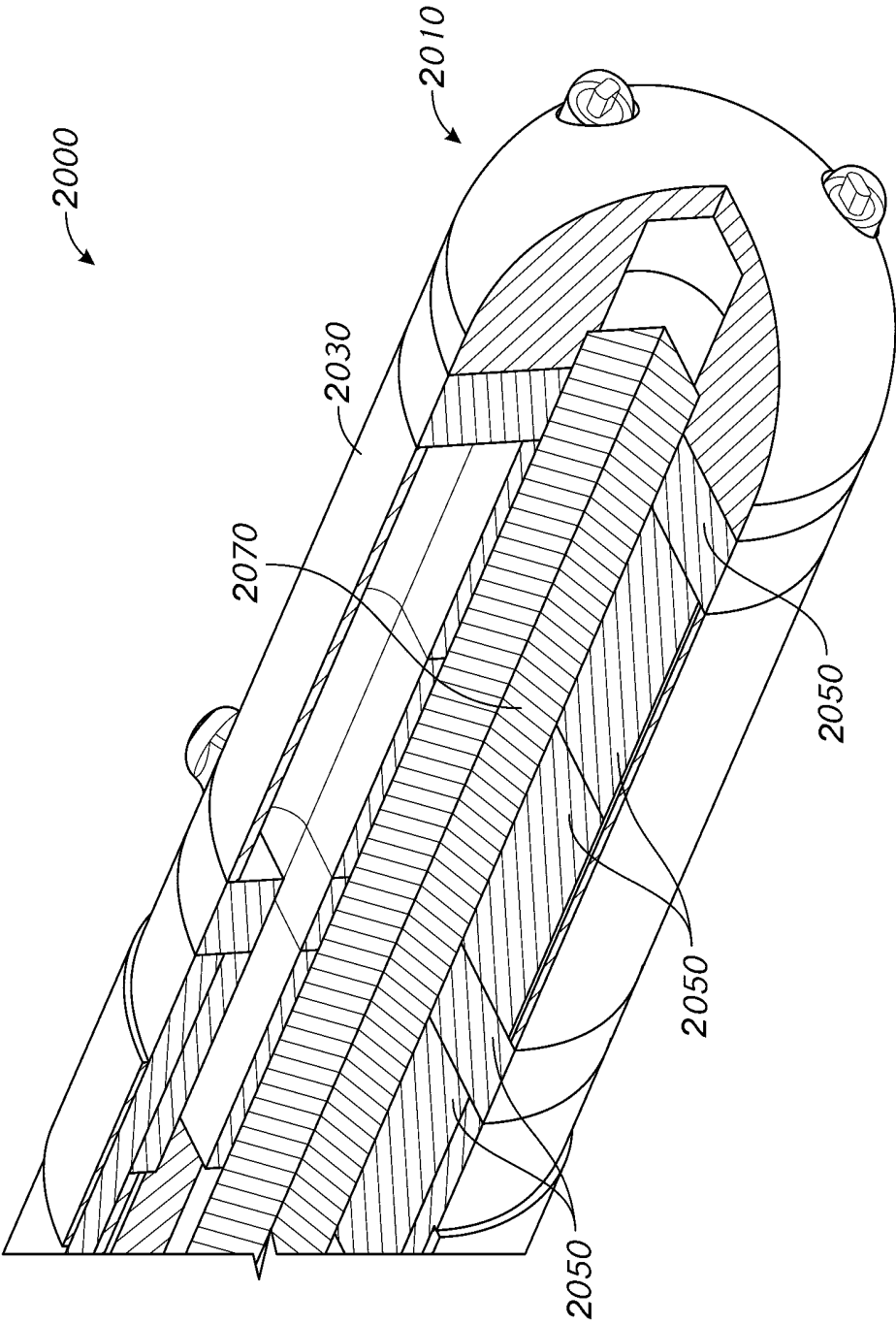

FIG. 15

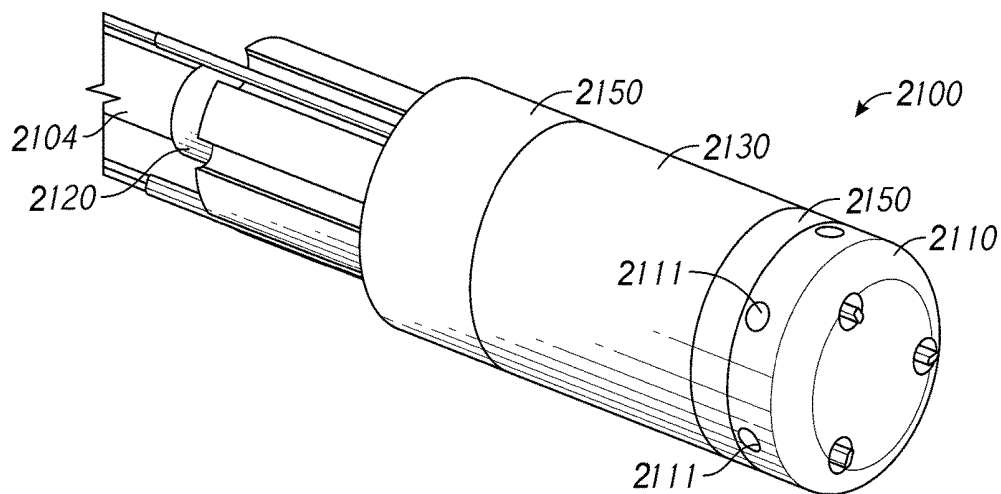

FIG. 16A

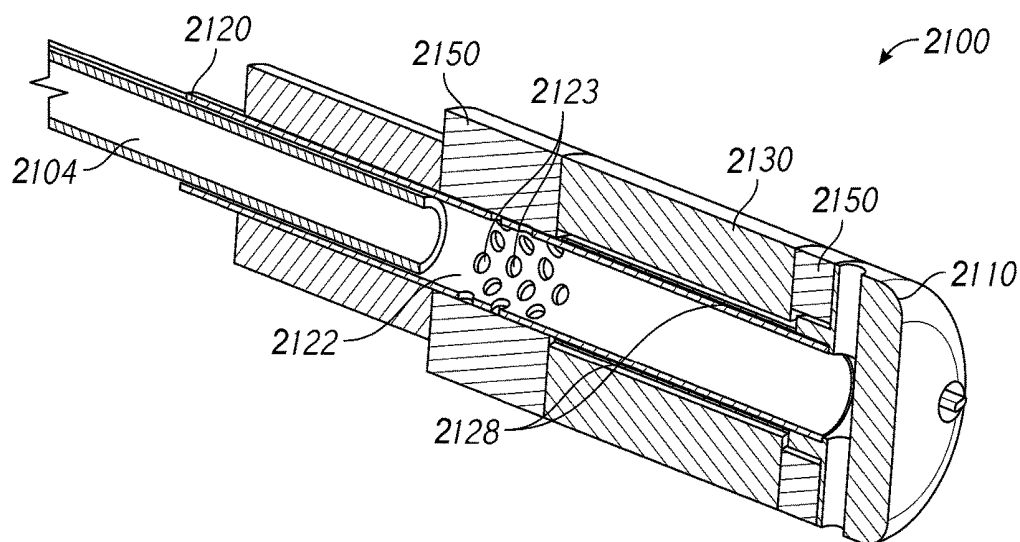

FIG. 16B

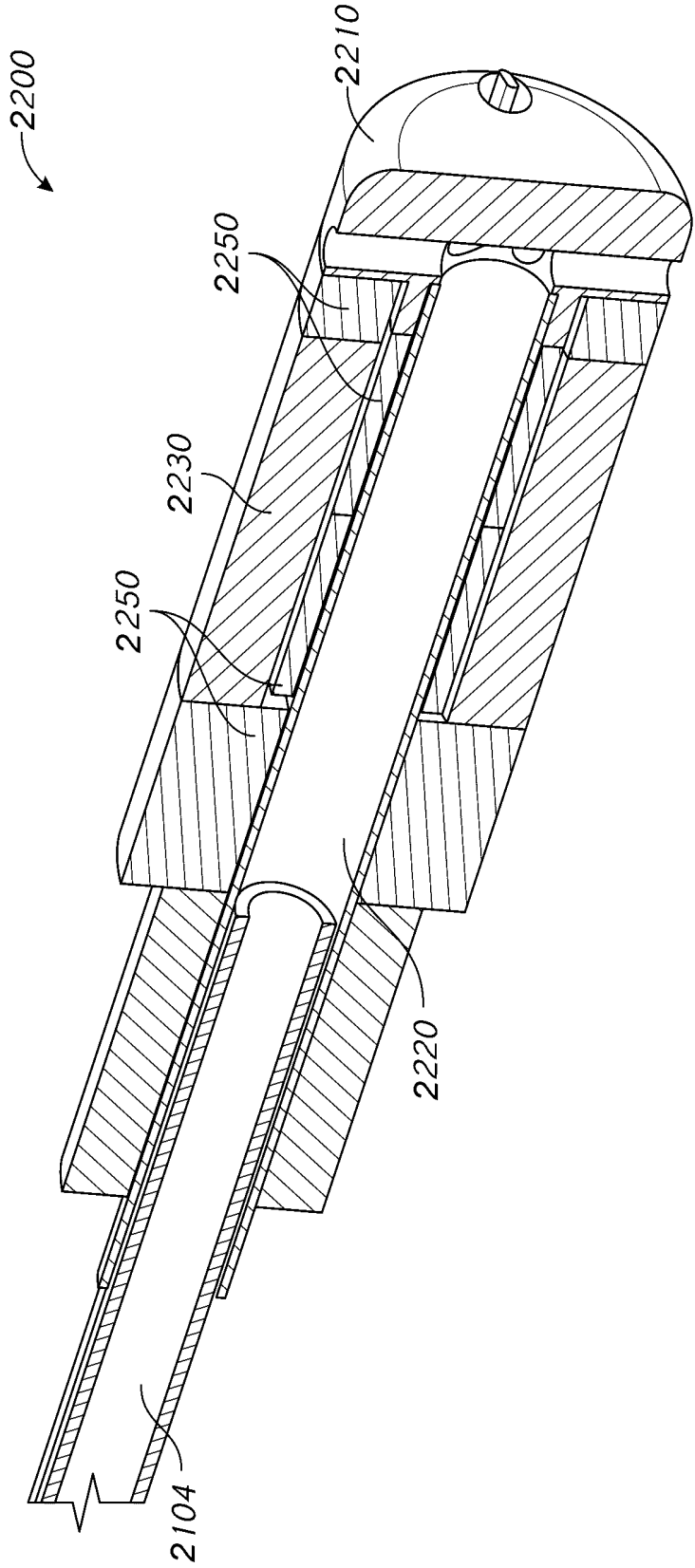

FIG. 16C

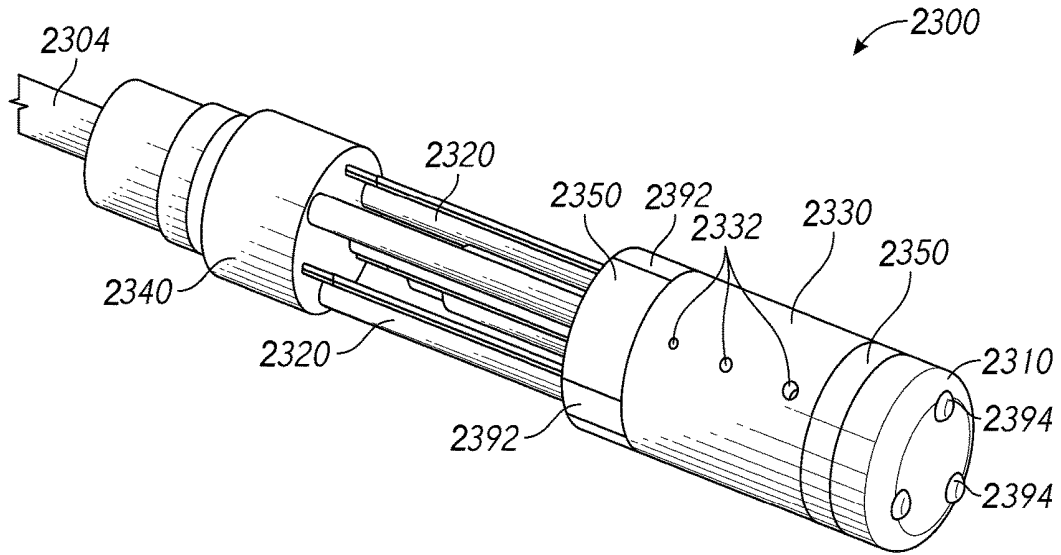

FIG. 17A

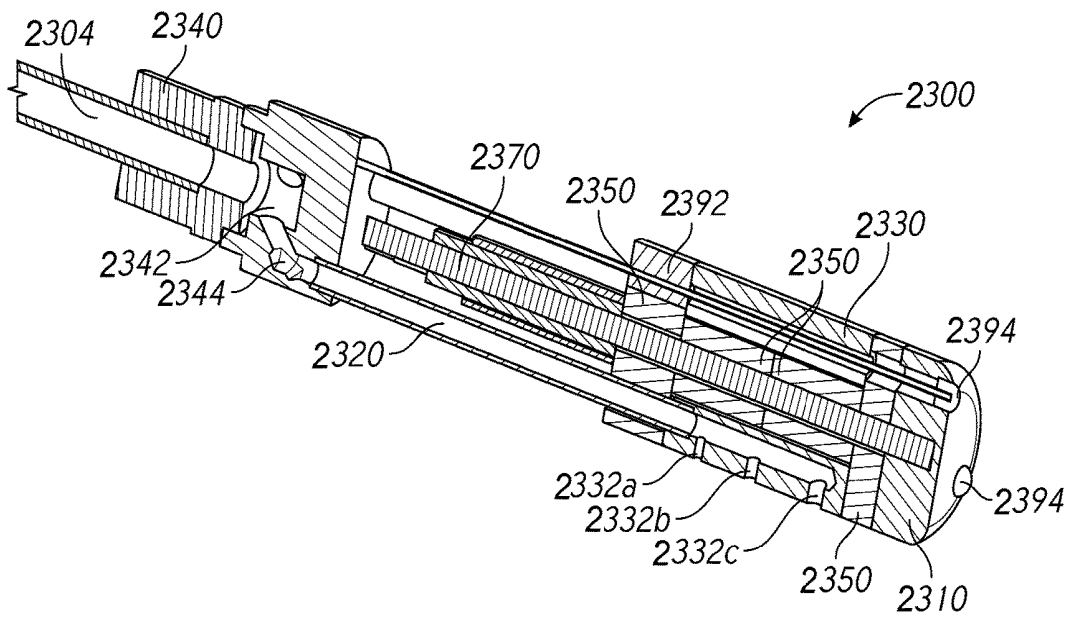

FIG. 17B

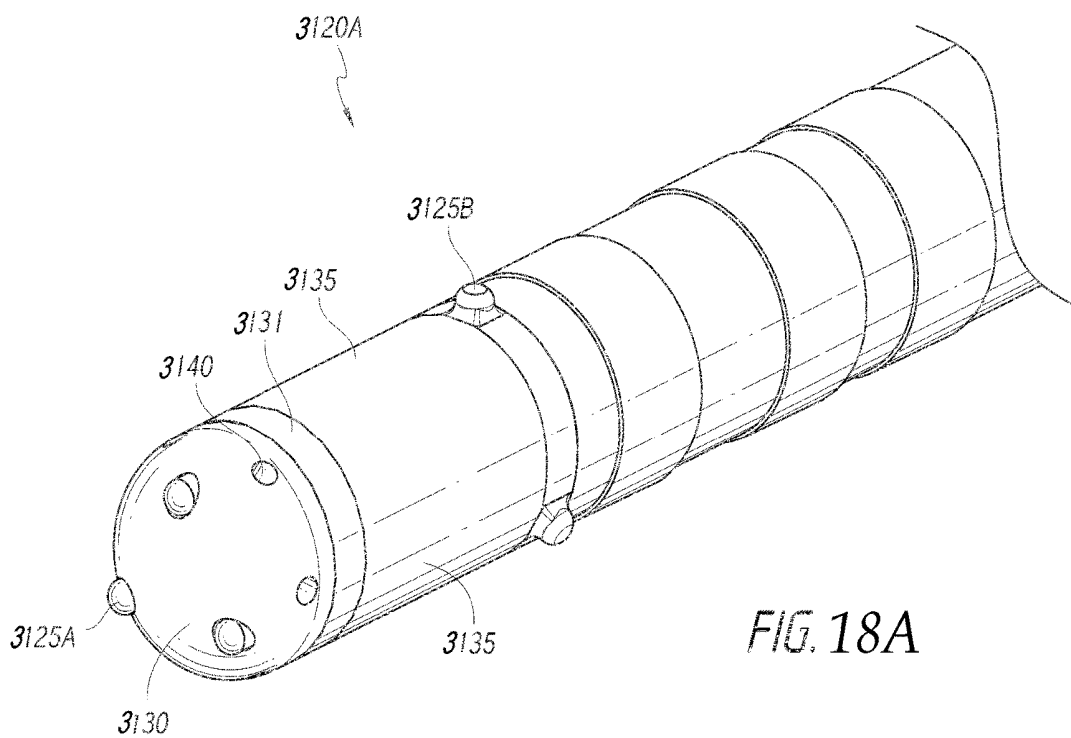

FIG. 18A

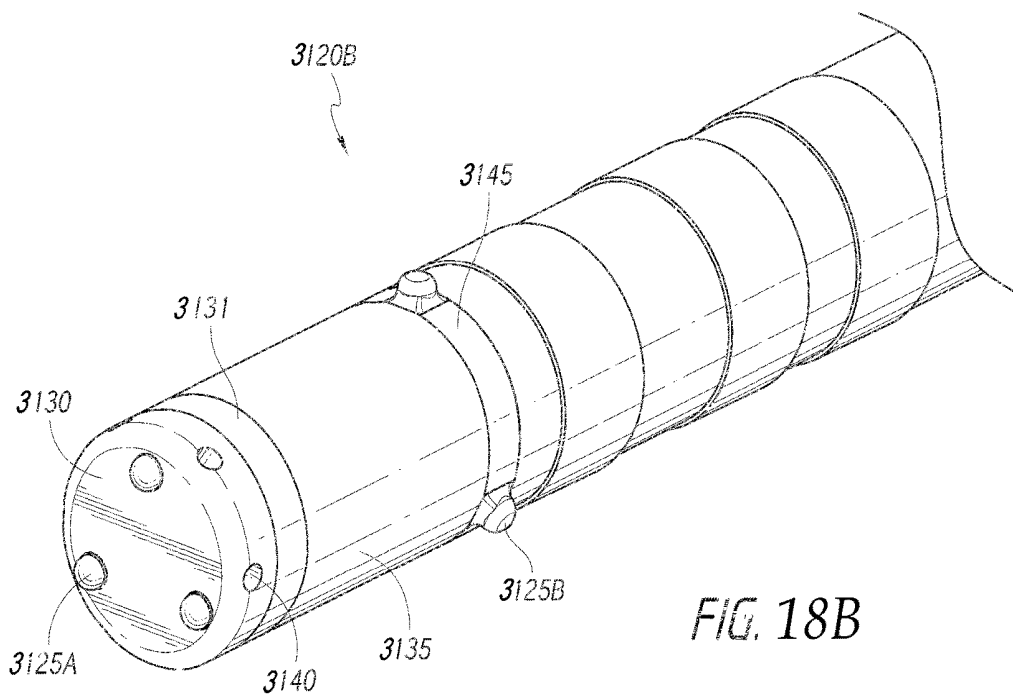
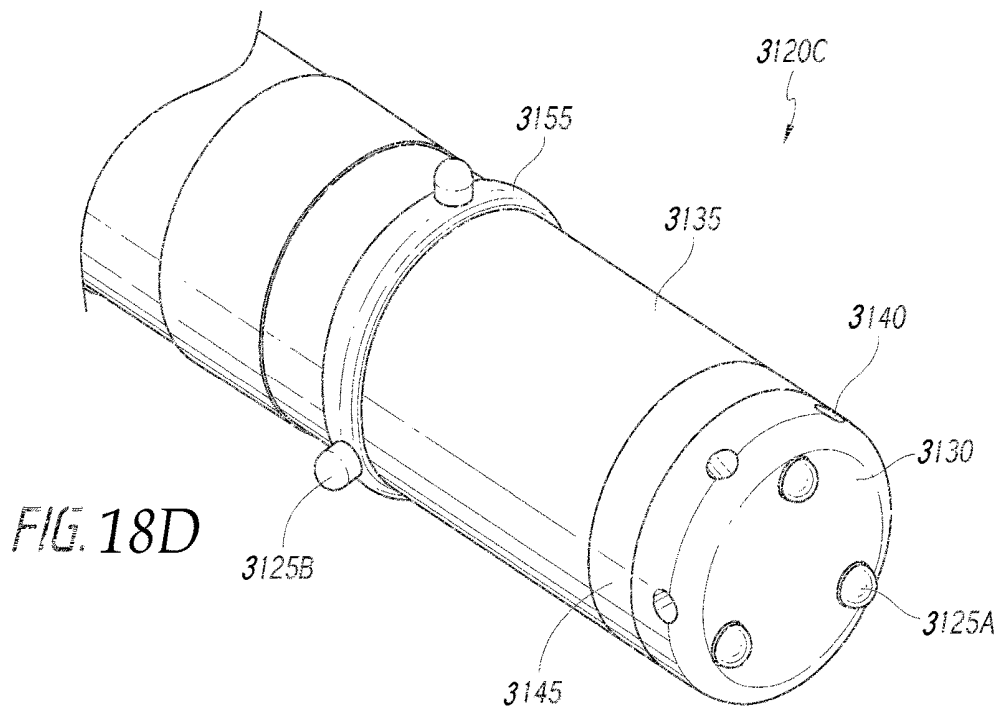
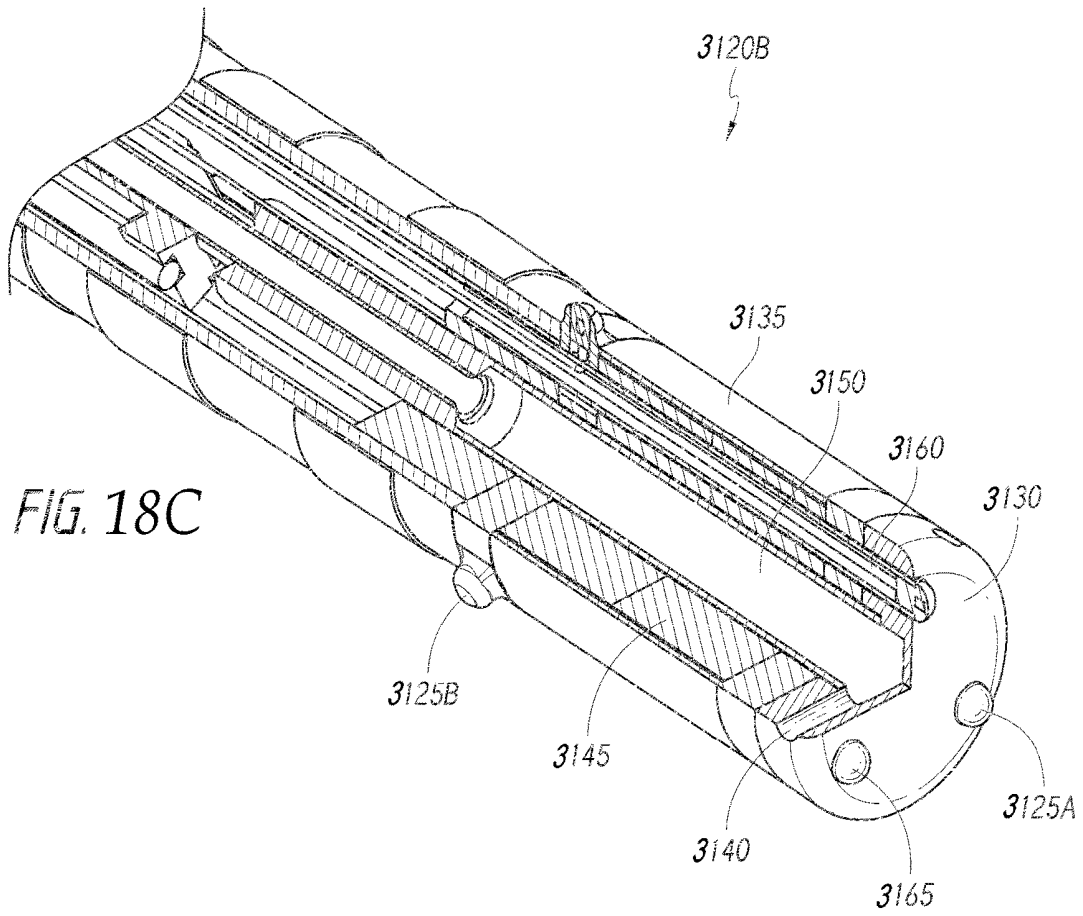

FIG. 18B



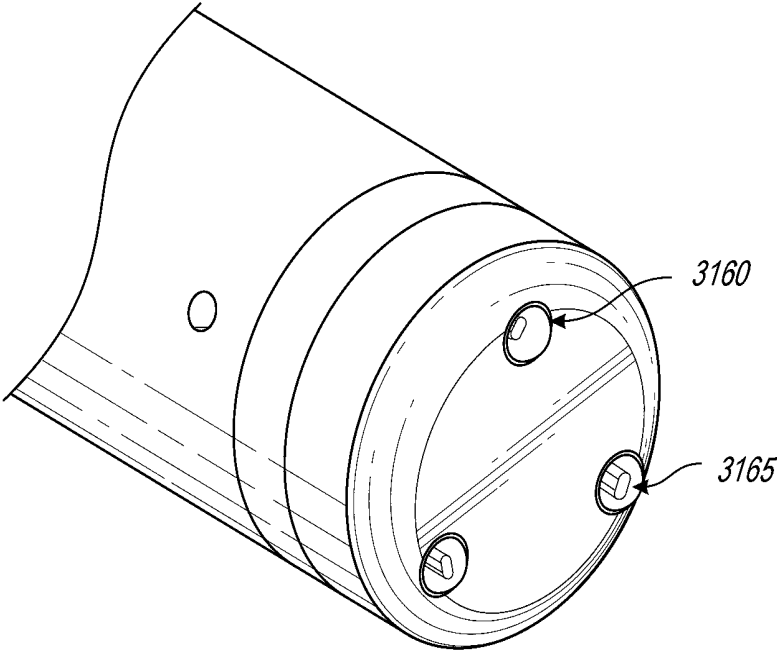

FIG. 18E

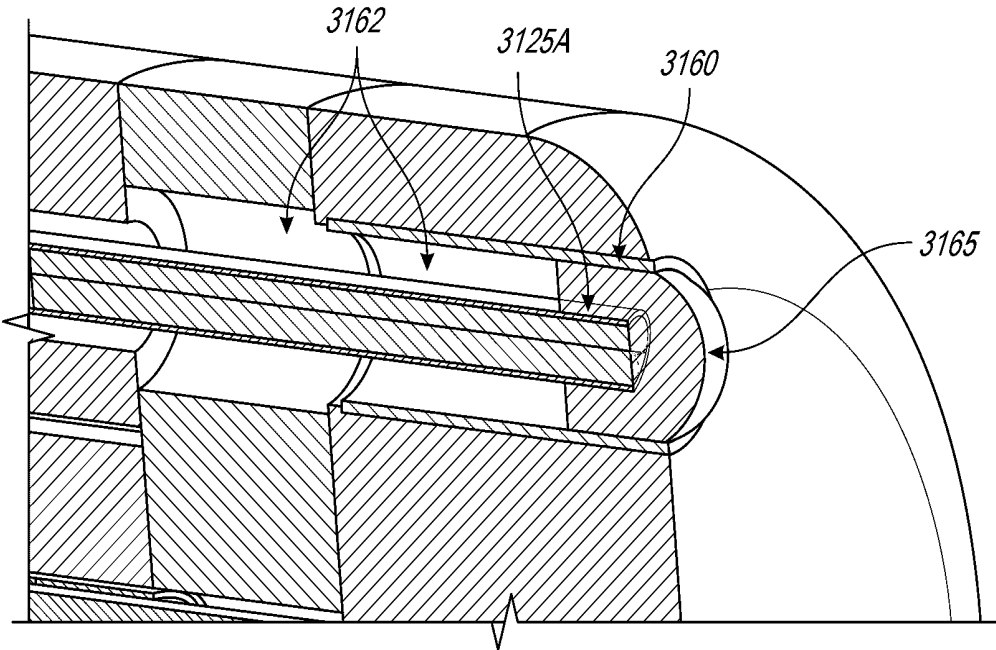

FIG. 18F

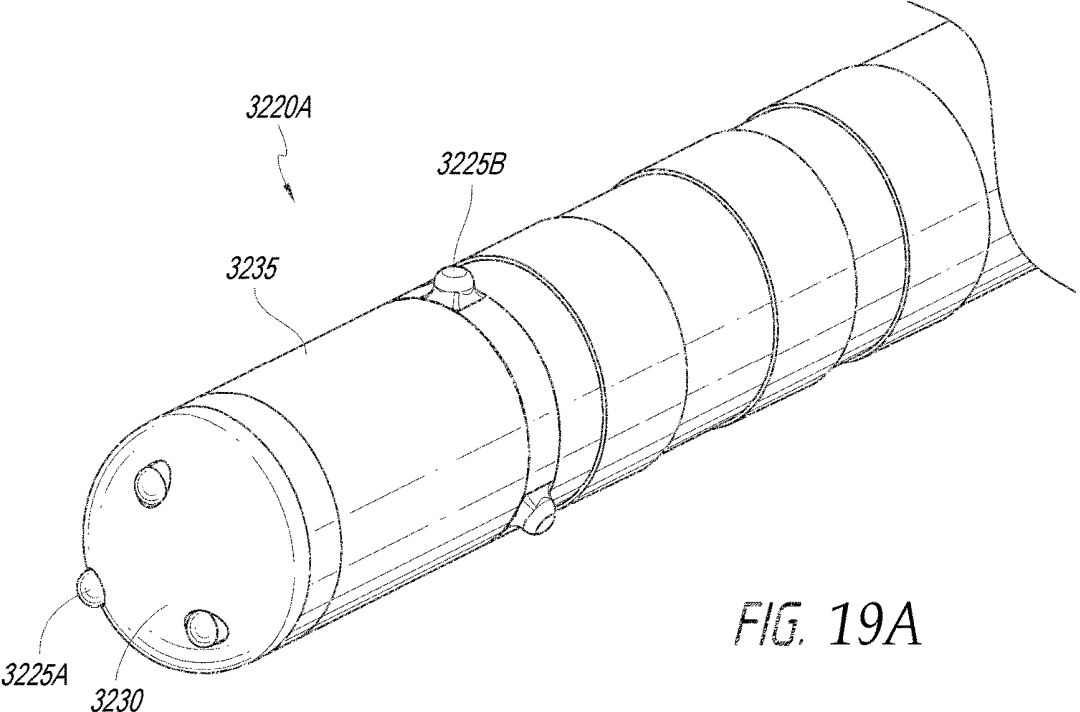

FIG. 19A

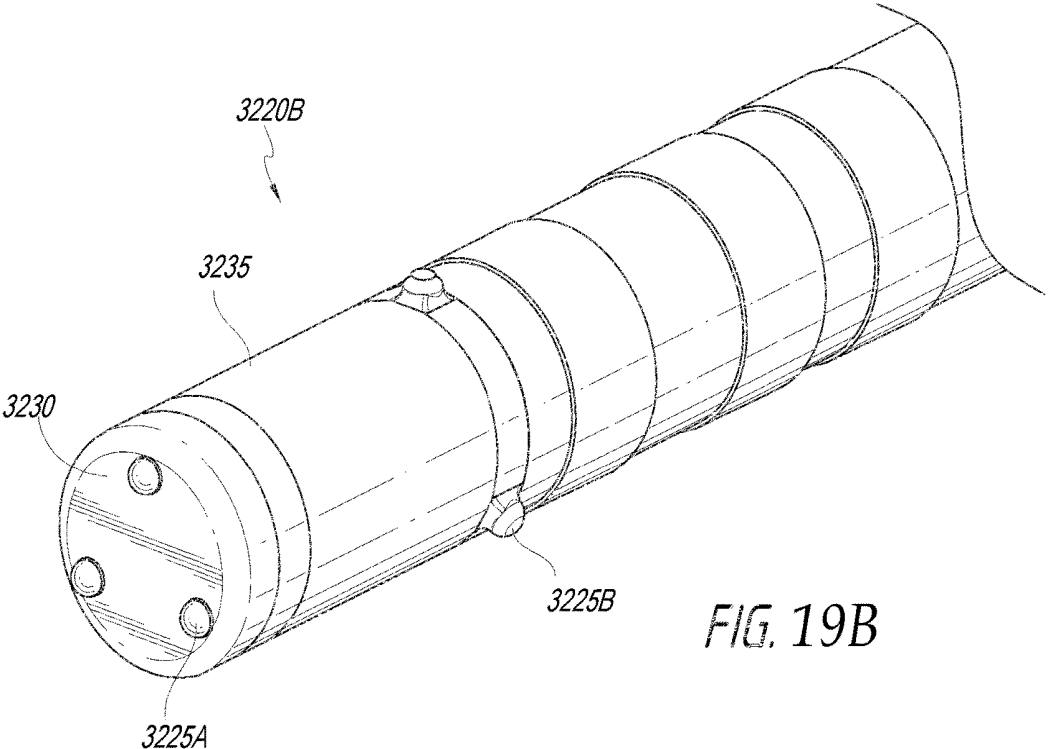
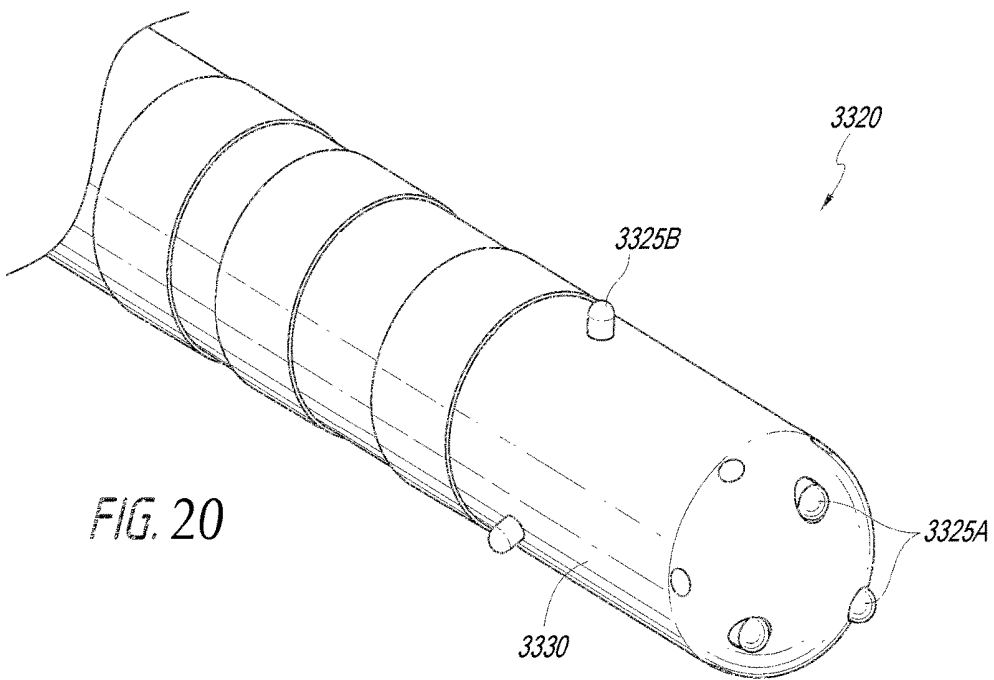
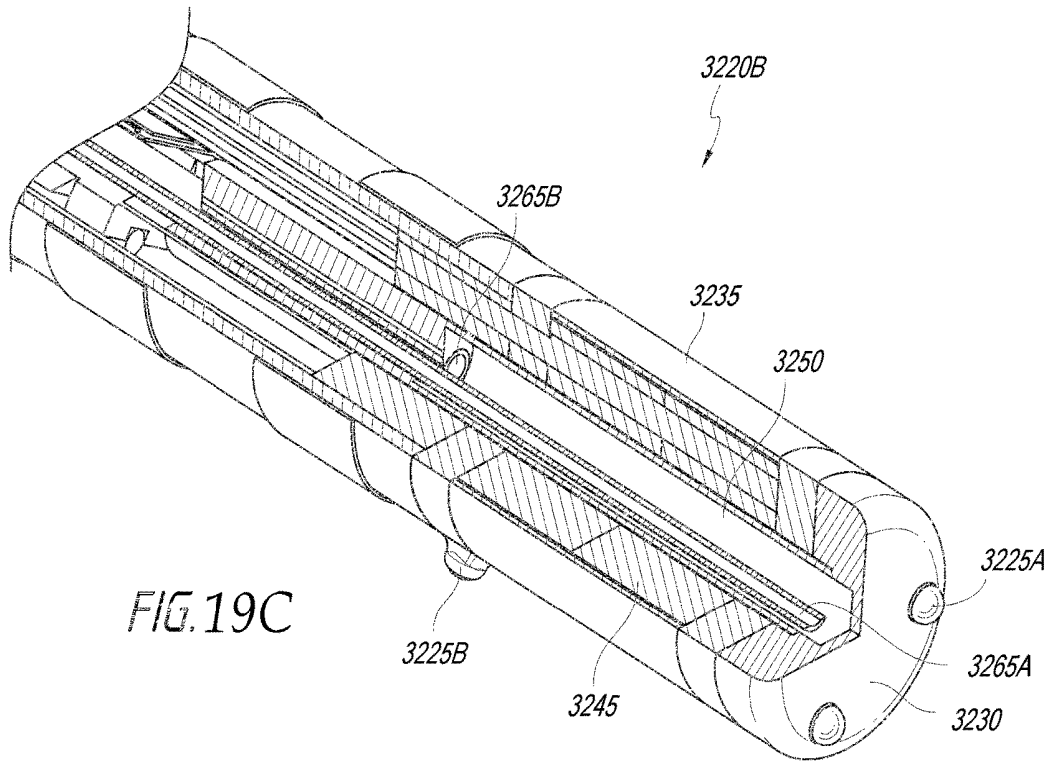

FIG. 19B



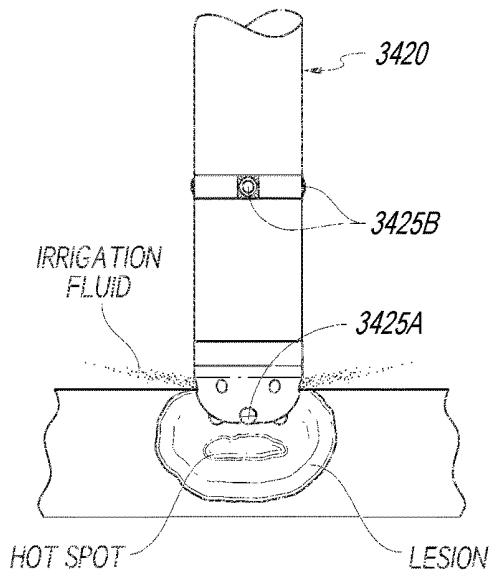

FIG. 21A

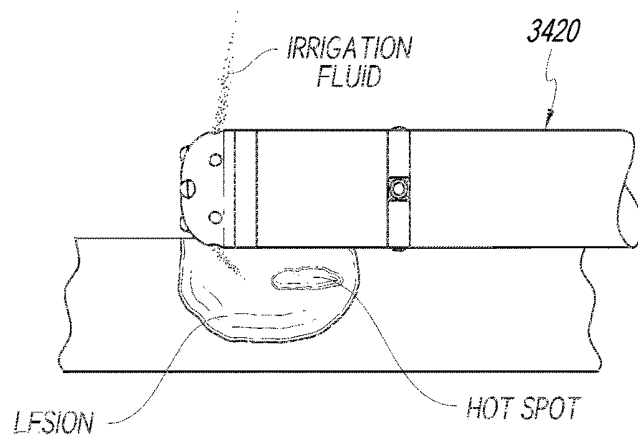

FIG. 21B

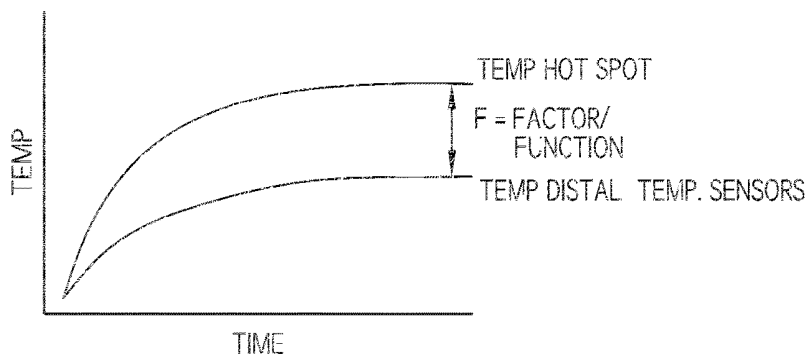

FIG. 22A

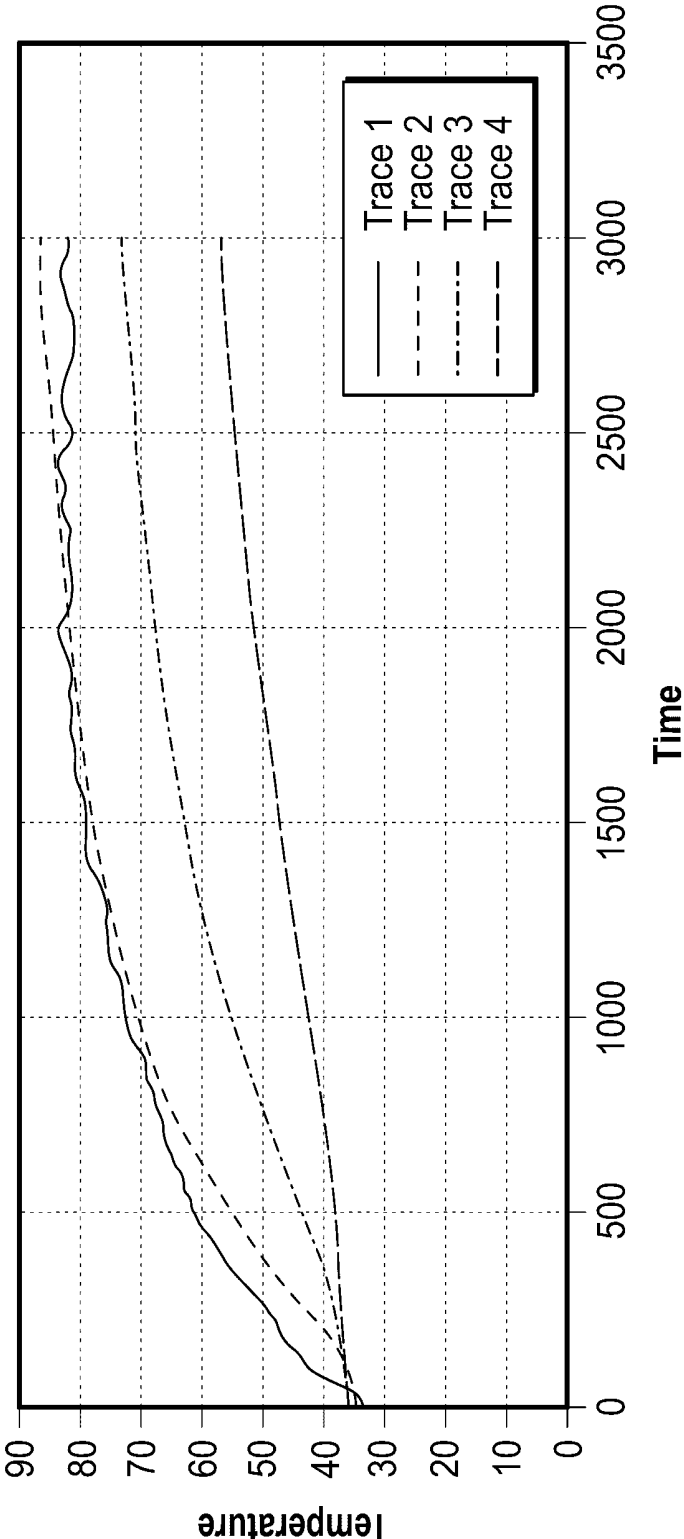

FIG. 22B

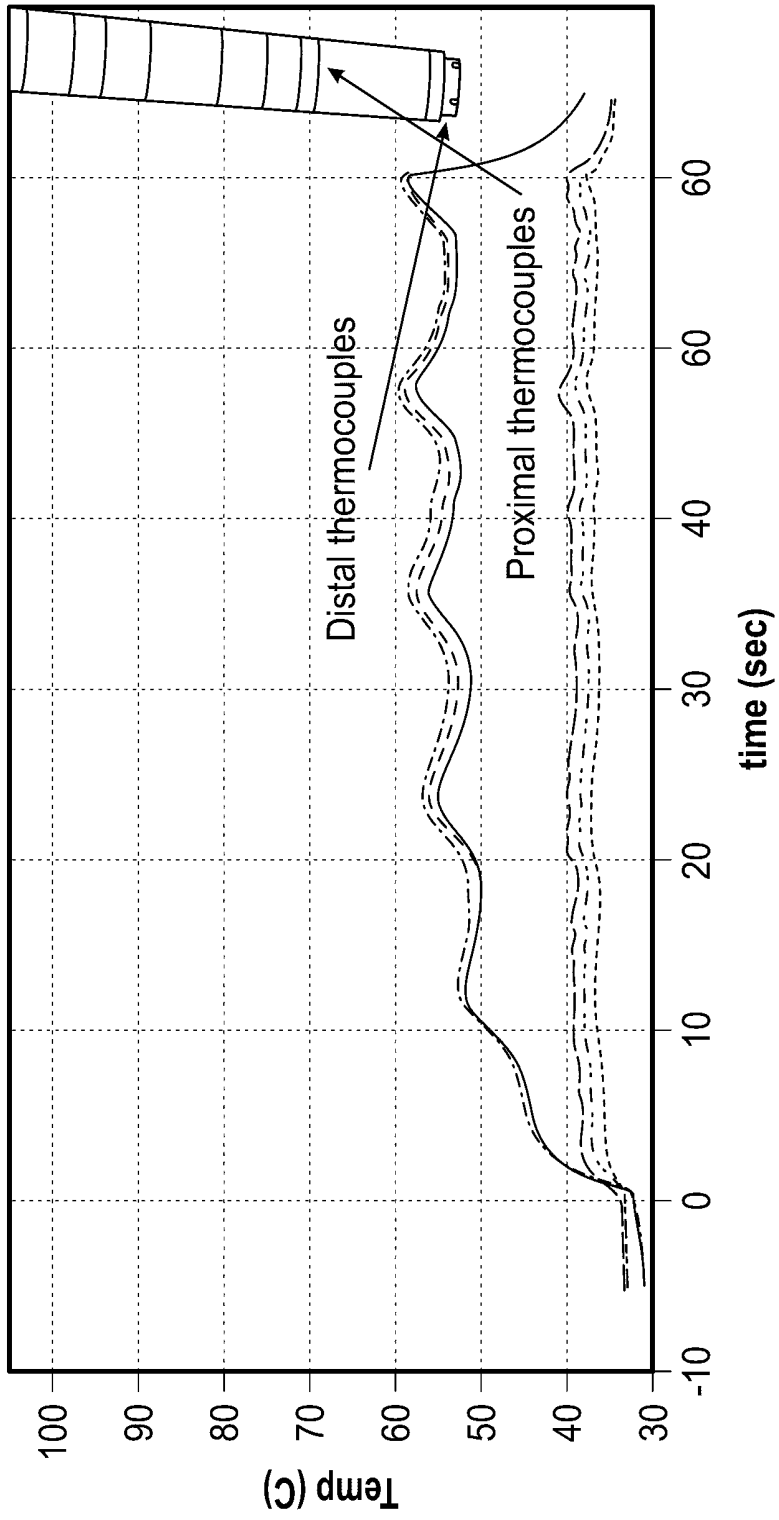

FIG. 23A

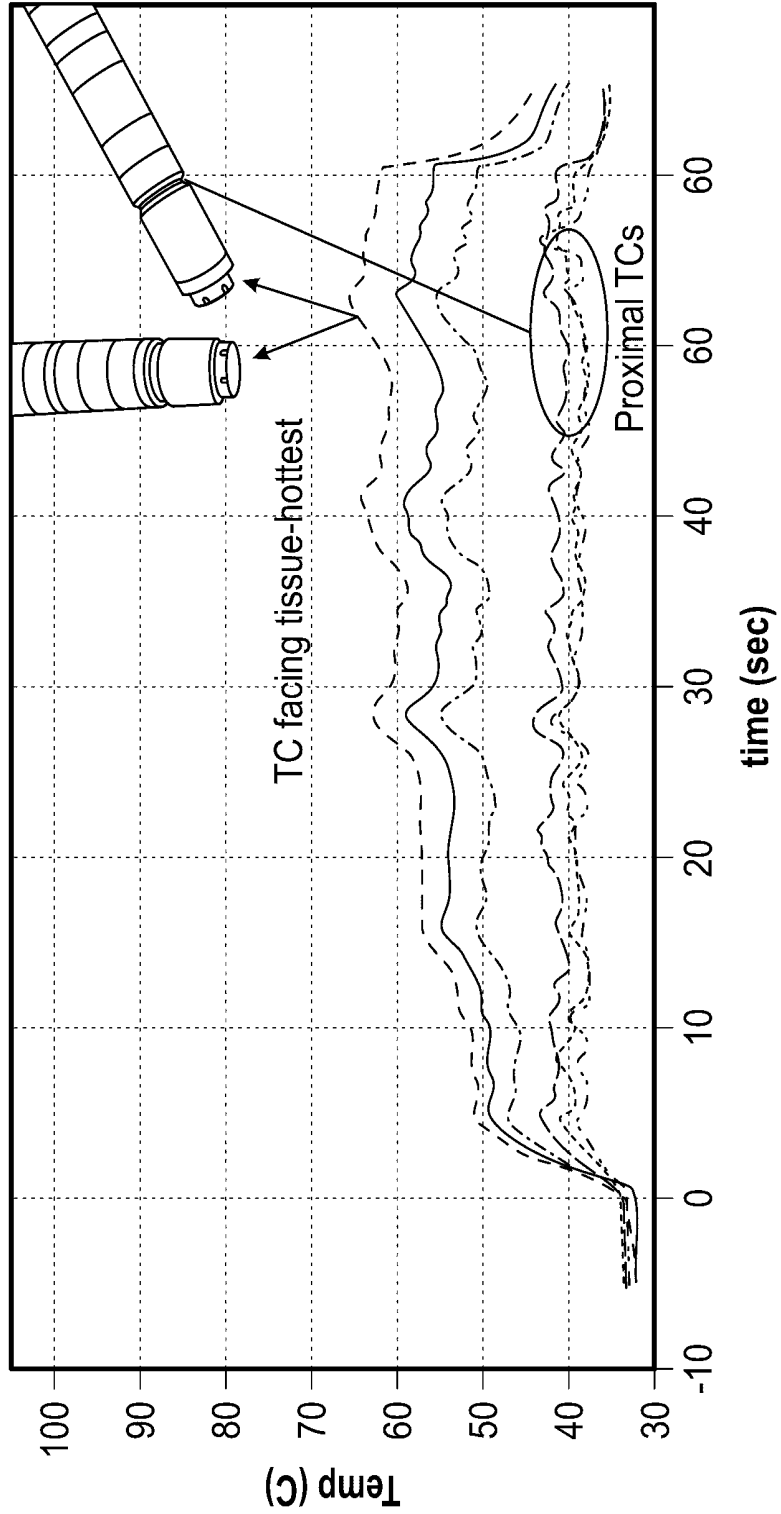

FIG. 23B

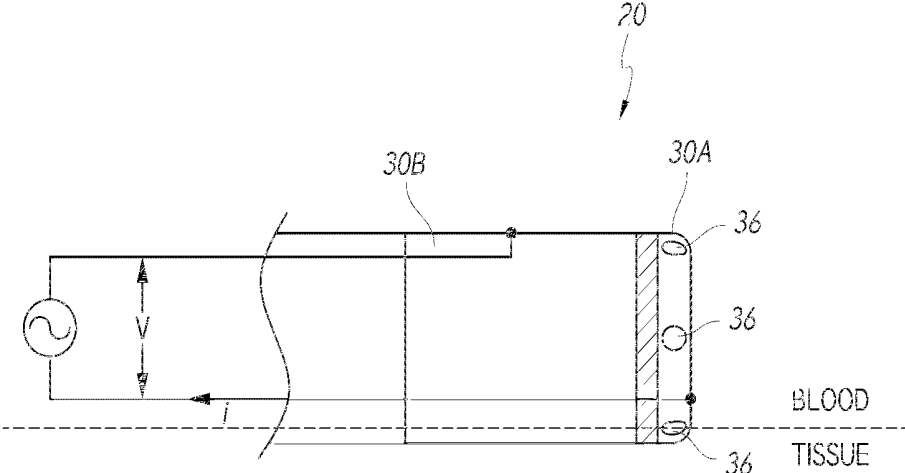

FIG. 24

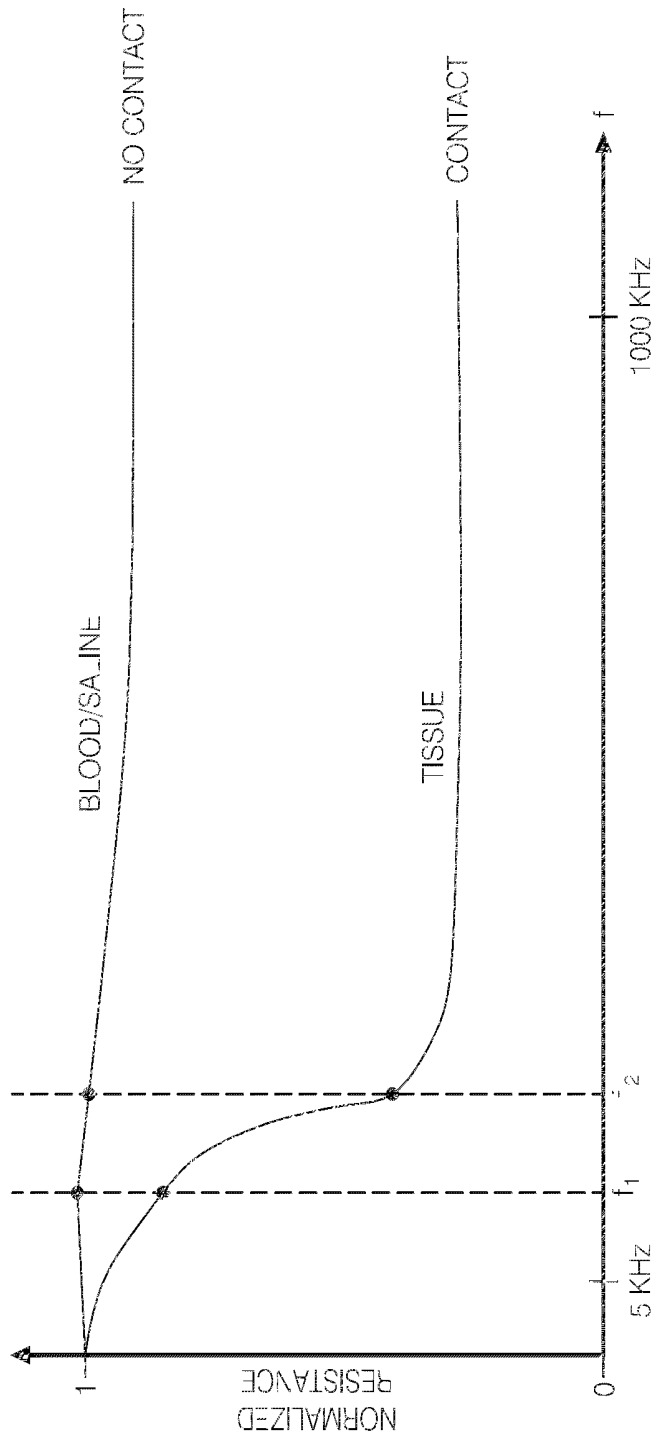

FIG. 25A

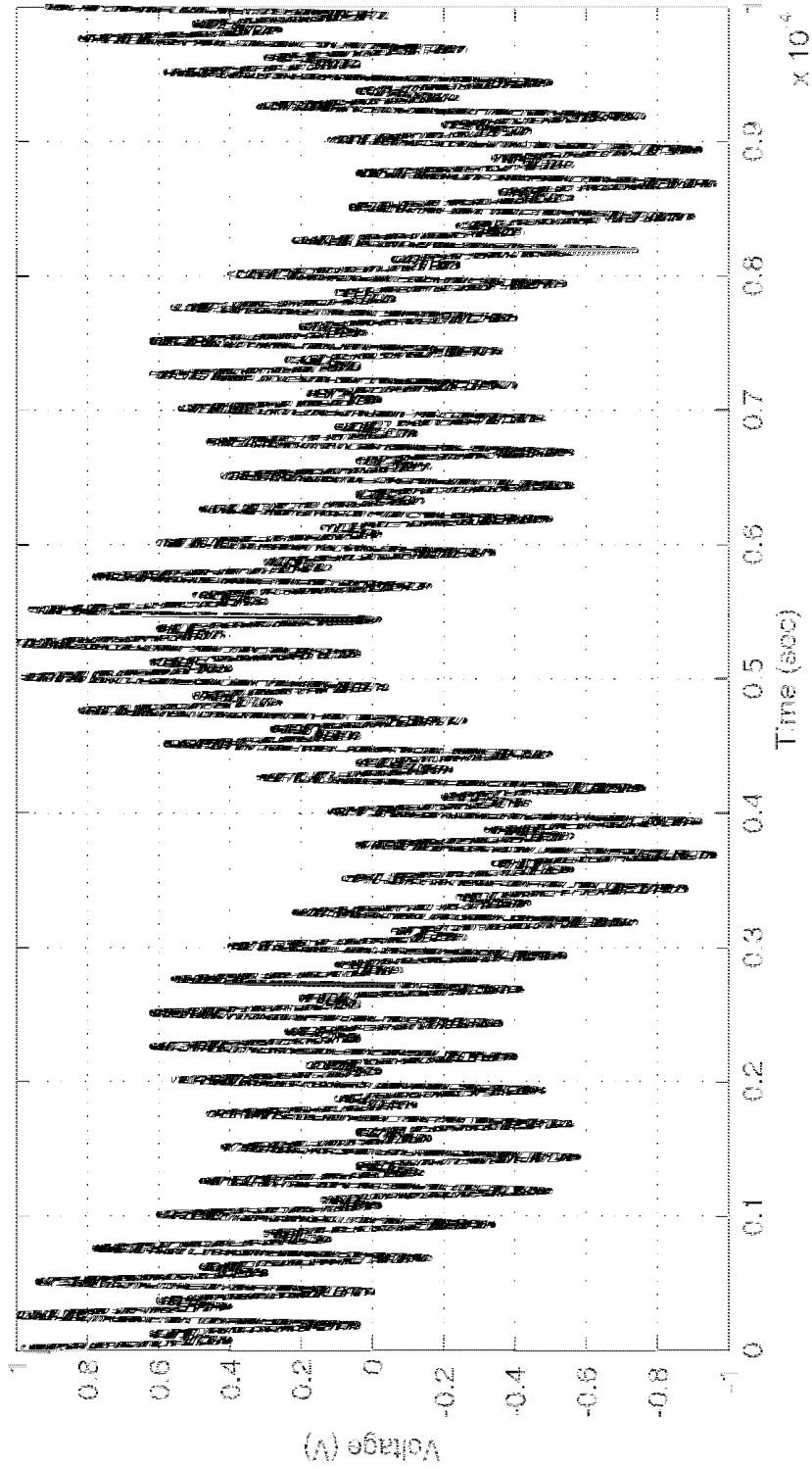

FIG. 25B

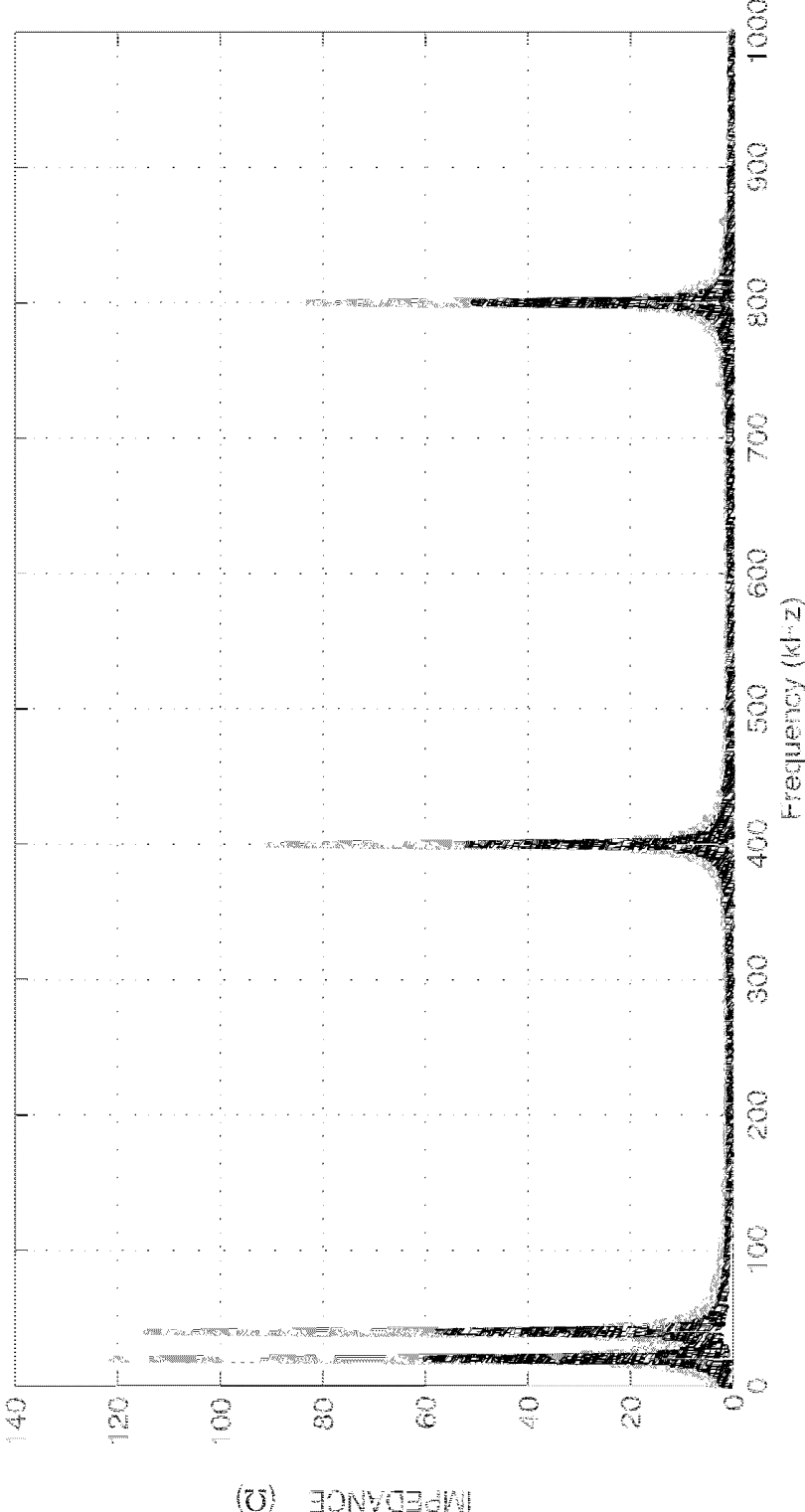

FIG. 25C

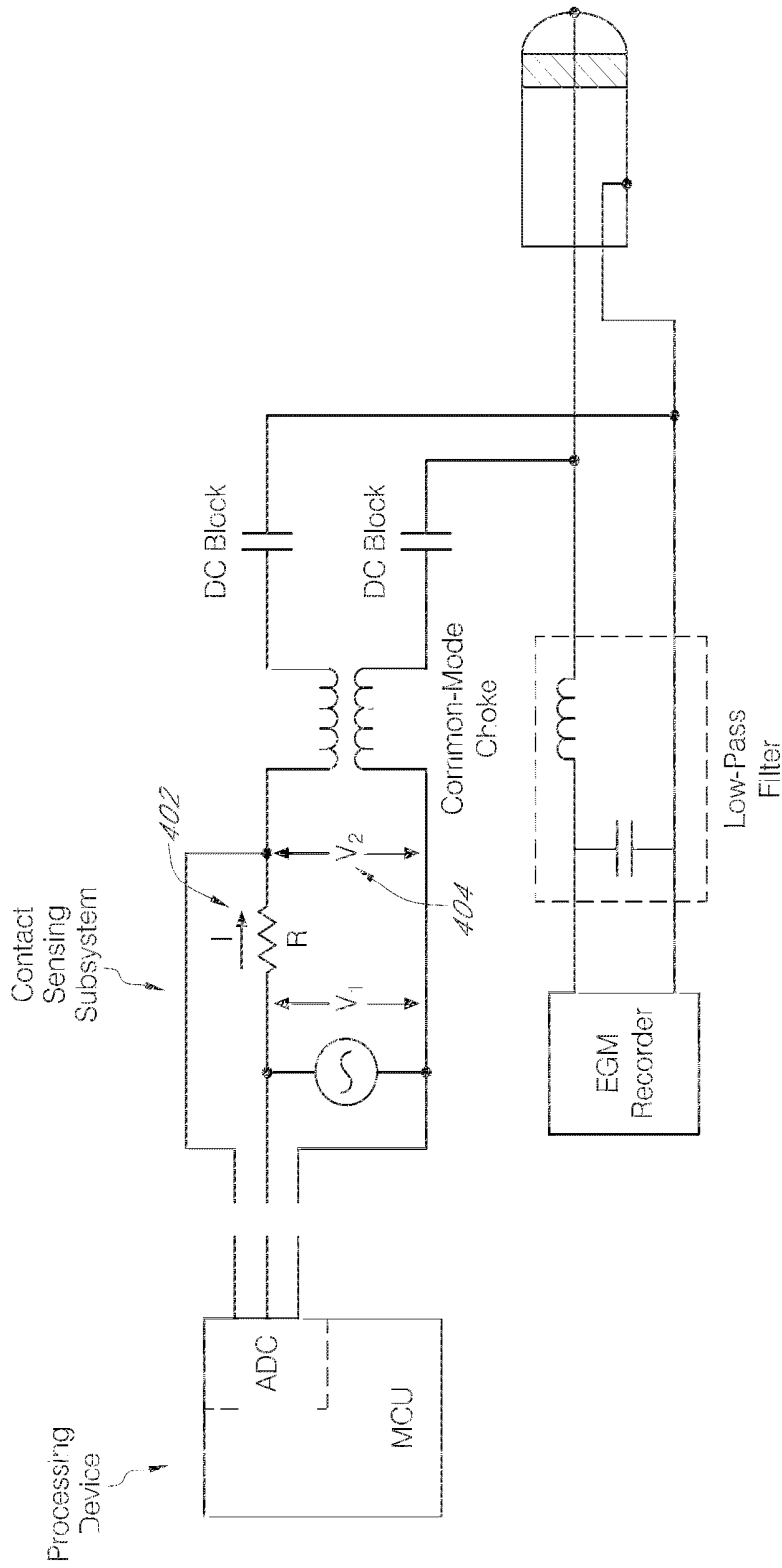

FIG. 25D

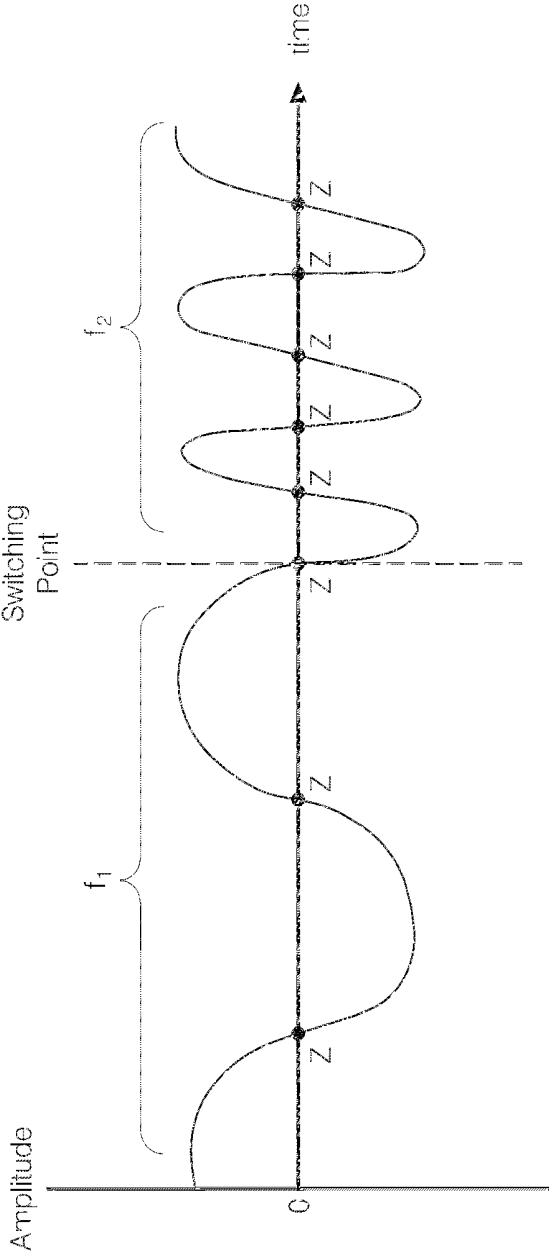

FIG. 26A

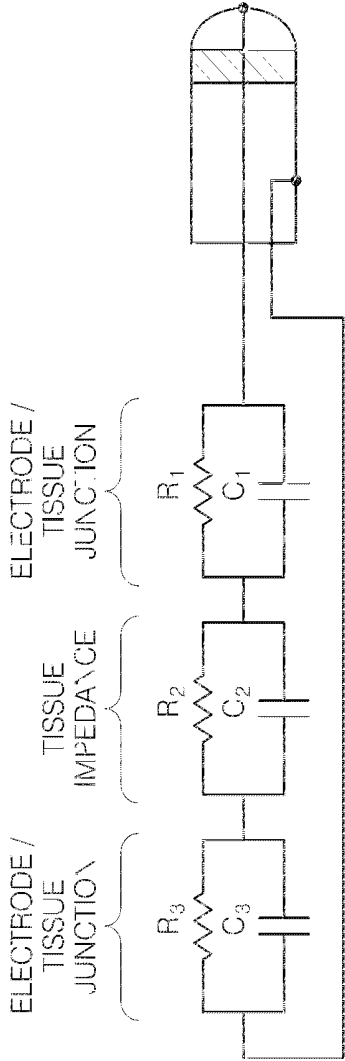

FIG. 26B

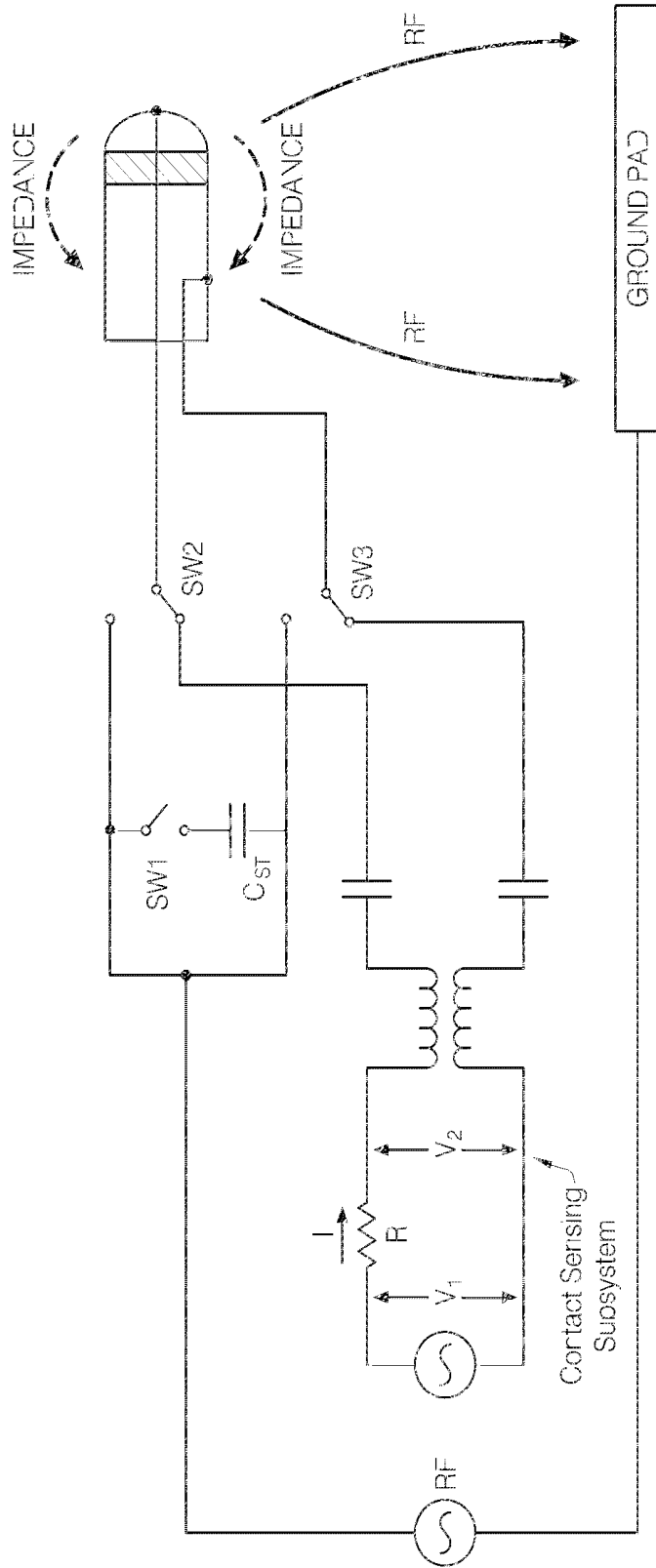

FIG. 26C

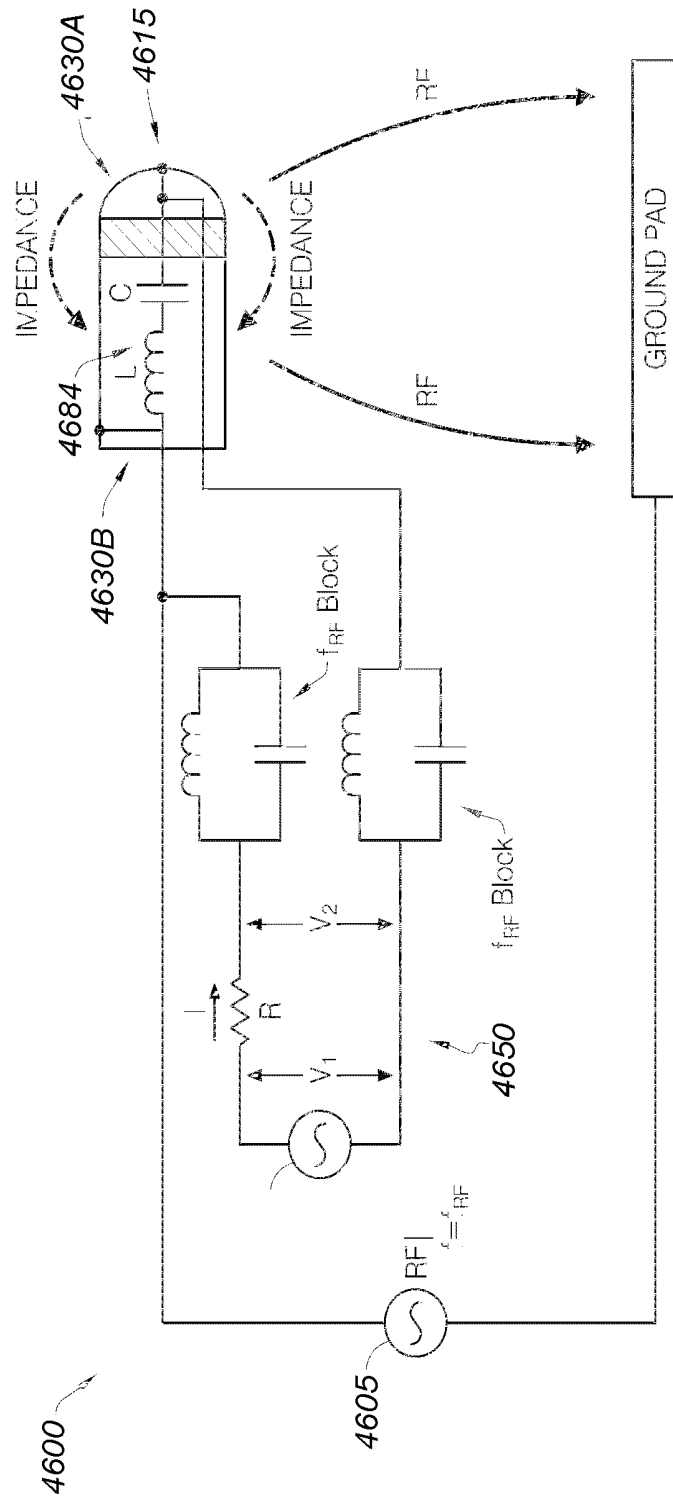

FIG. 27

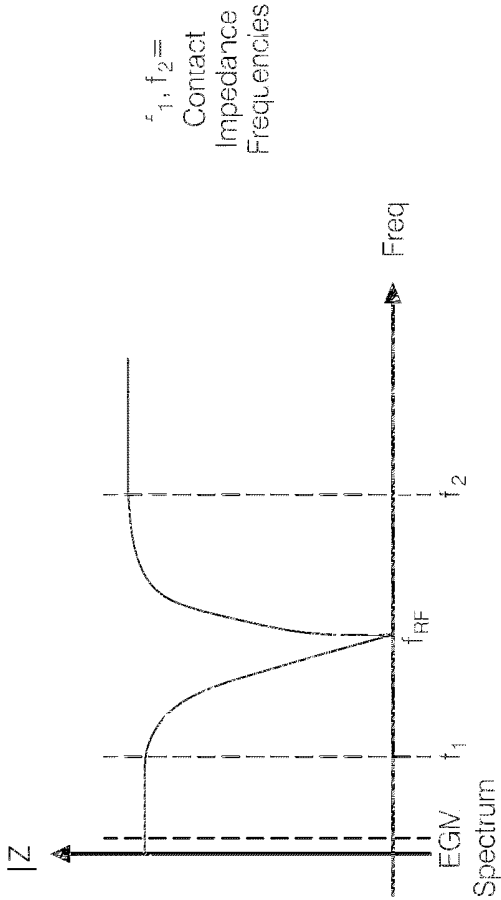

FIG. 28

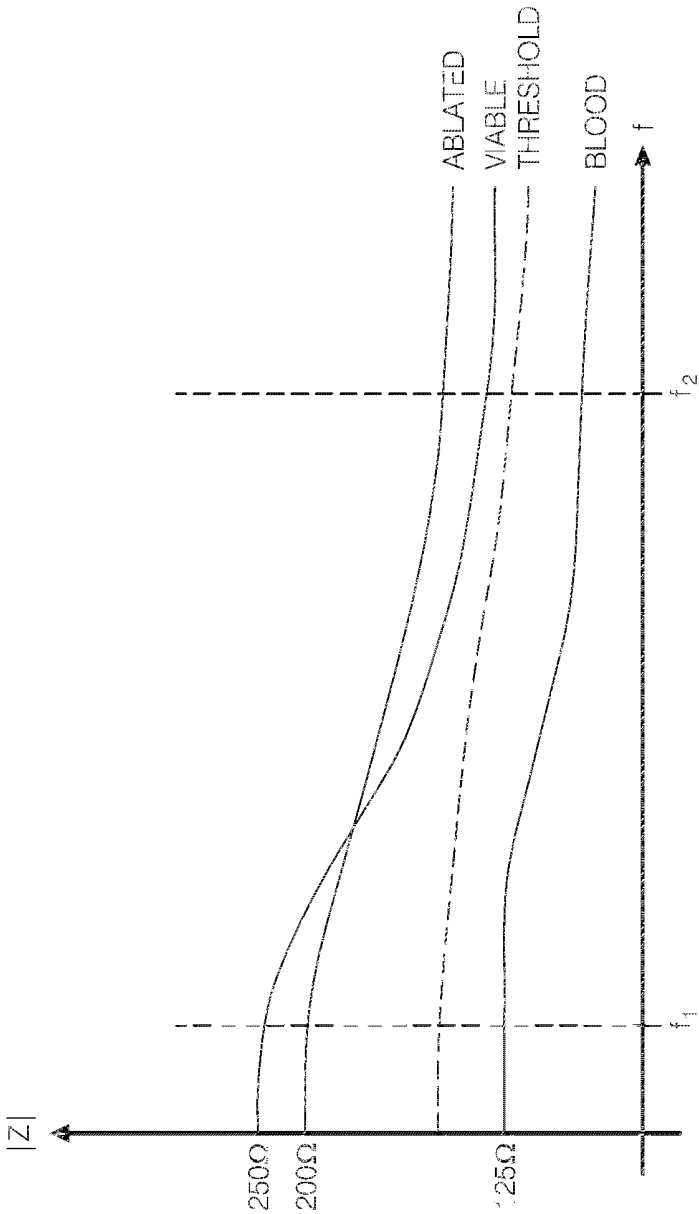

FIG. 29

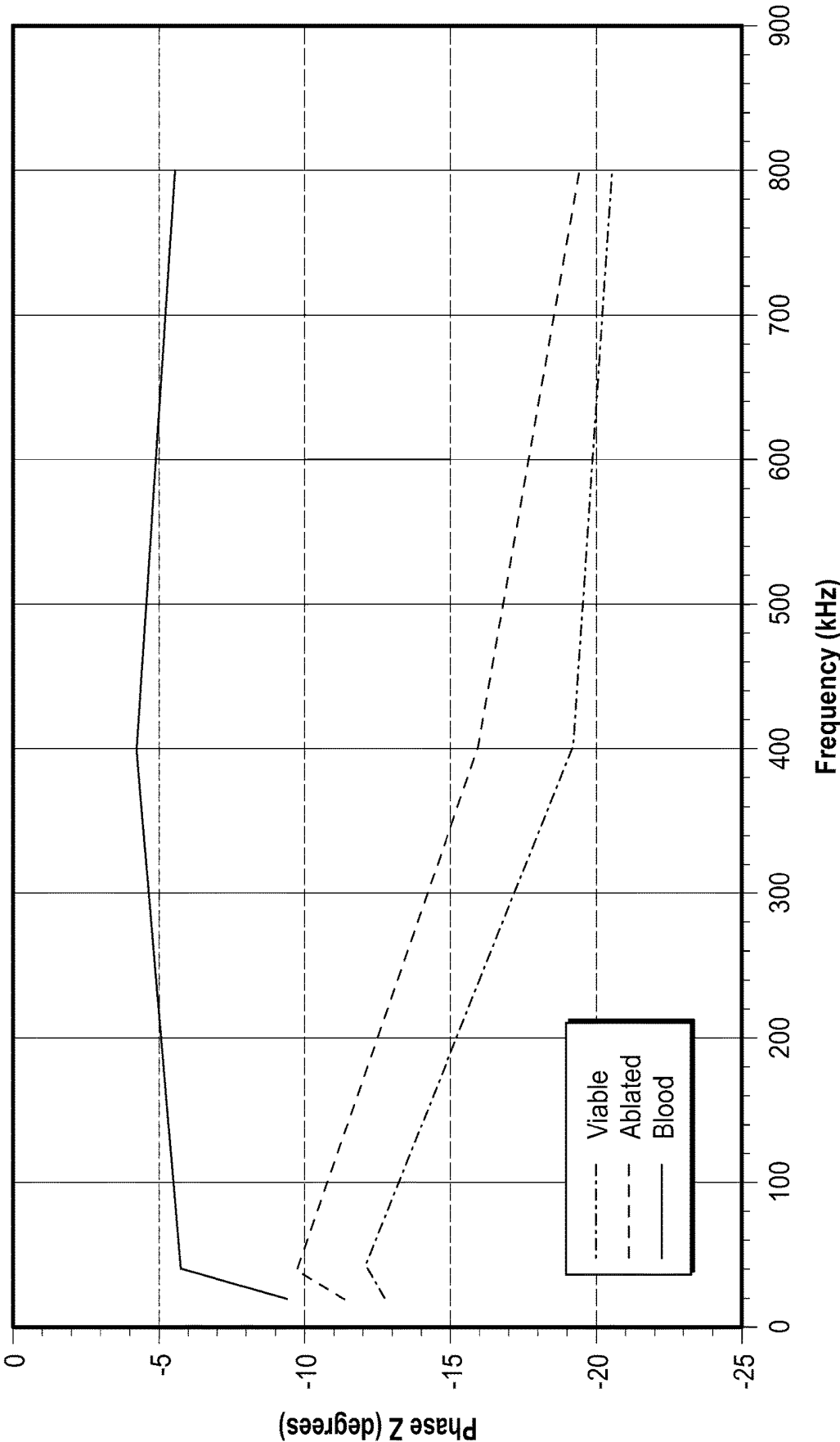

FIG. 30

5000

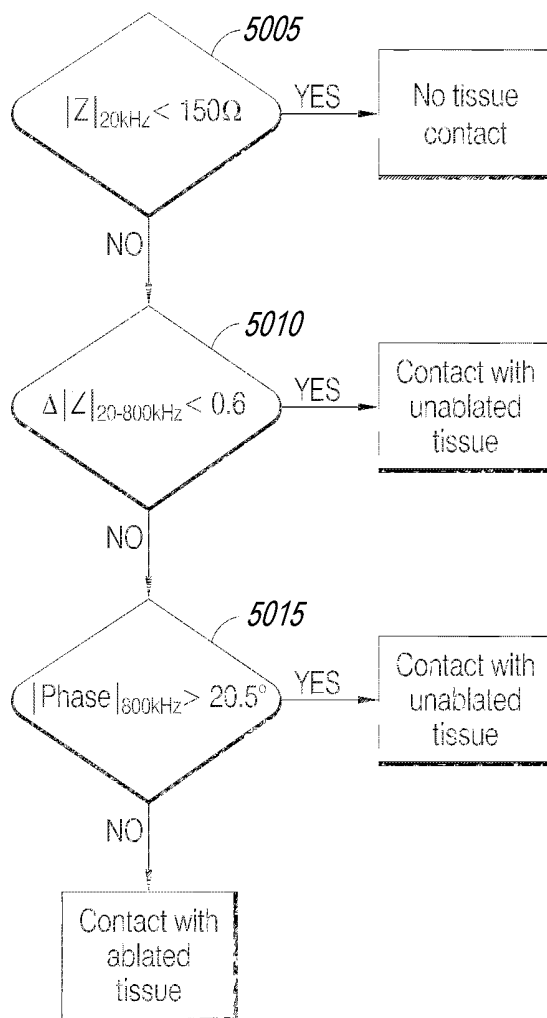

FIG. 31

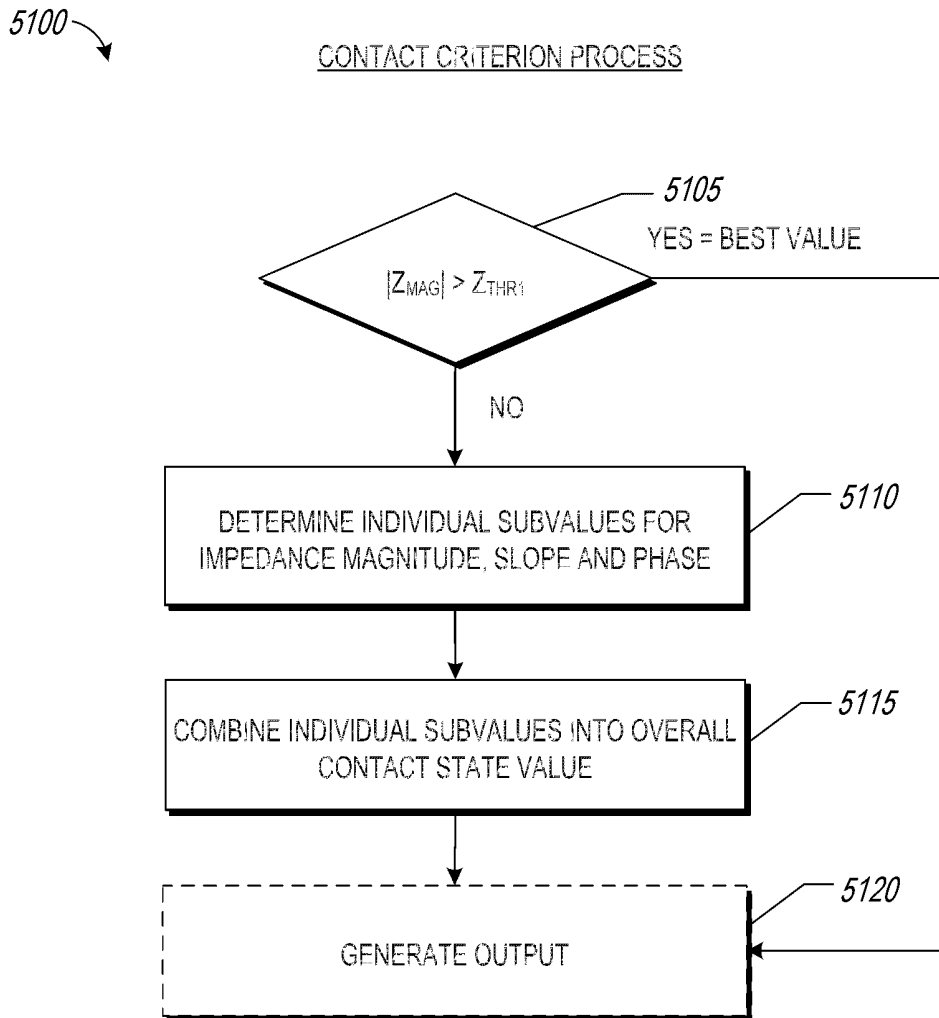

FIG. 32

5110 ↗

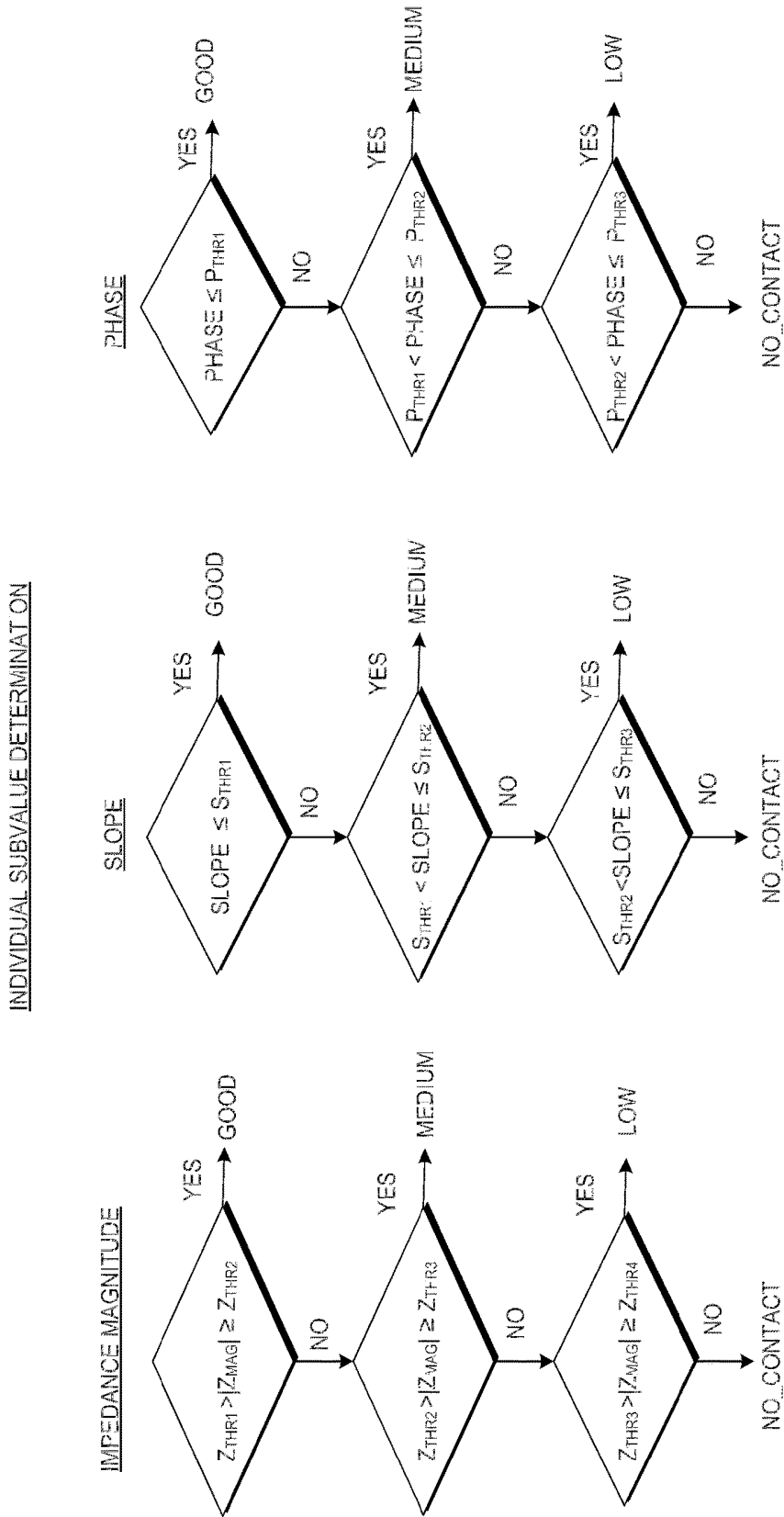

FIG. 32A

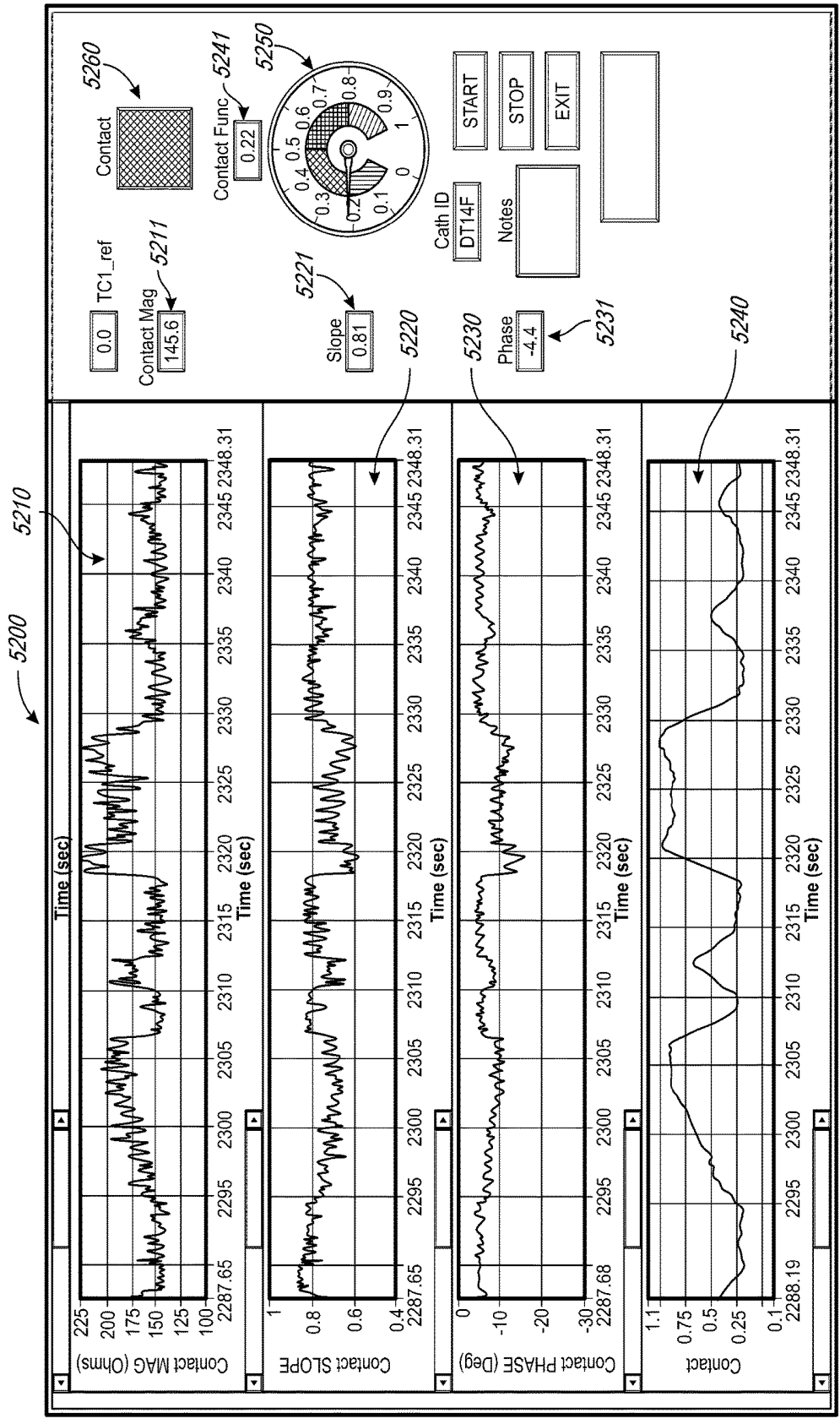

FIG. 33

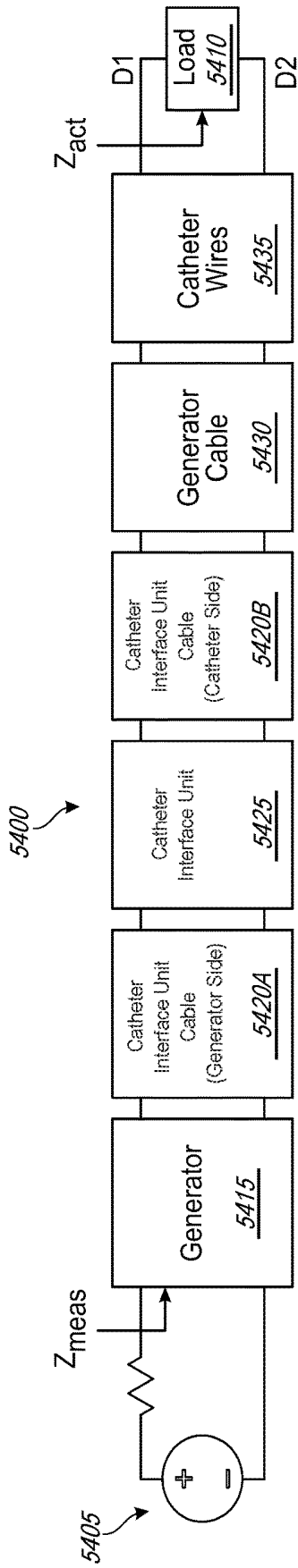

FIG. 34A

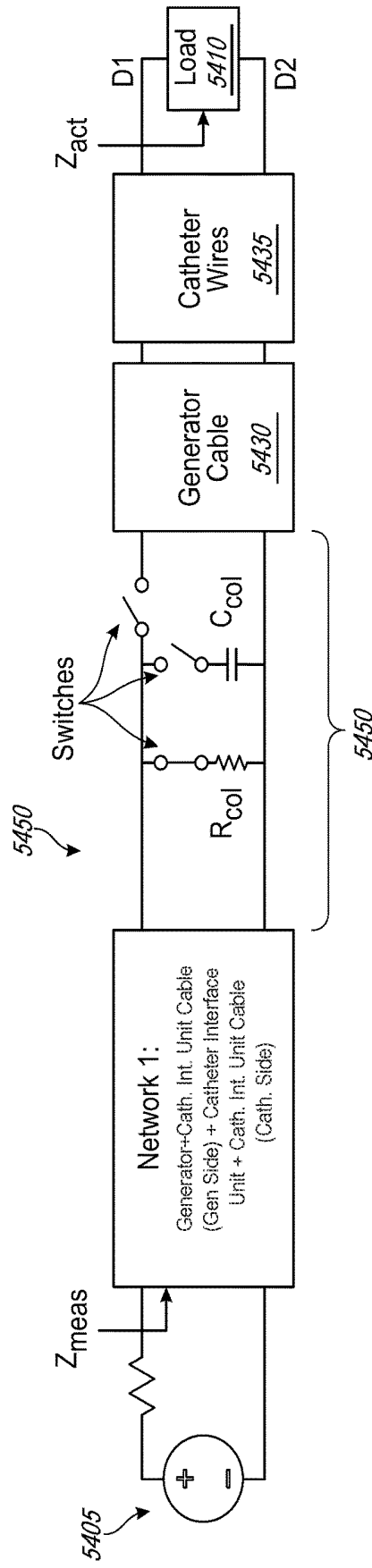

FIG. 34B

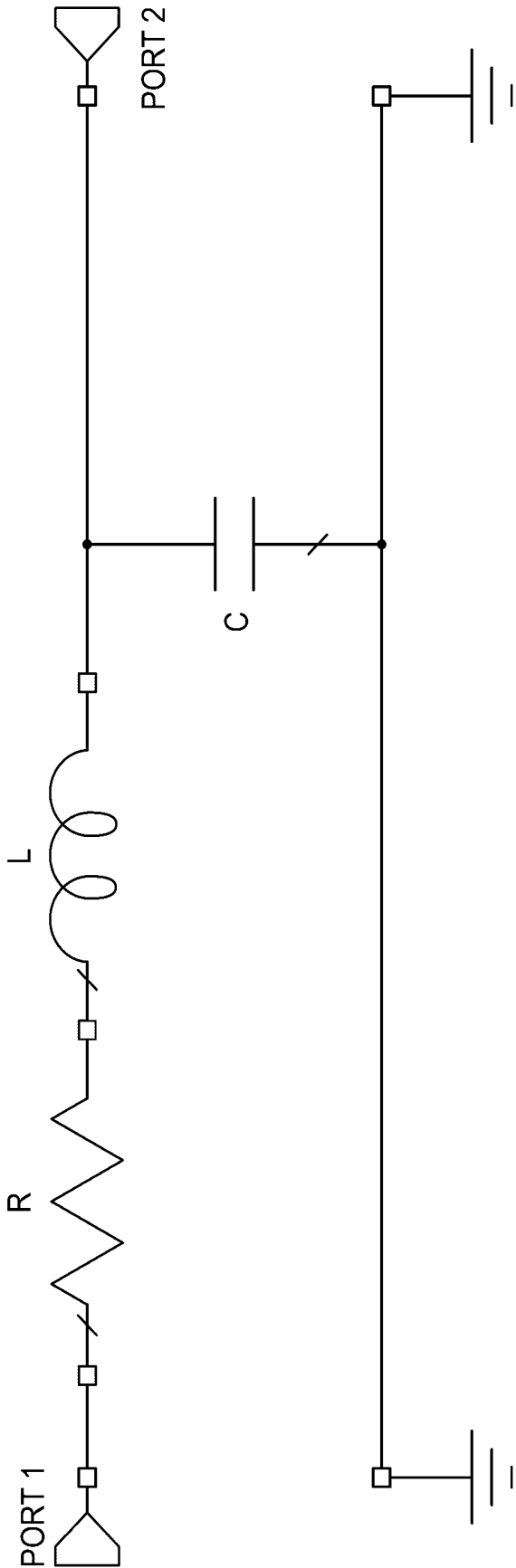

FIG. 34C

## METHODS OF REMOVING HEAT FROM AN ELECTRODE USING THERMAL SHUNTING

### RELATED APPLICATIONS

[0001] This application is a continuation of U.S. patent application Ser. No. 15/336,648 filed Oct. 27, 2016, which is a continuation of U.S. patent application Ser. No. 15/214,376 filed Jul. 19, 2016, which is a continuation of PCT Application No. PCT/US2015/061419 filed Nov. 18, 2015. PCT Application No. PCT/US2015/061419 claims priority to U.S. Provisional Application No. 62/081,710 filed Nov. 19, 2014, U.S. Provisional Application No. 62/094,892 filed Dec. 19, 2014, U.S. Provisional Application No. 62/135,046 filed Mar. 18, 2015, U.S. Provisional Application No. 62/135,025 filed Mar. 18, 2015, U.S. Provisional Application No. 62/211,539 filed Aug. 28, 2015, and U.S. Provisional Application No. 62/138,338 filed Mar. 25, 2015. The contents of each of the above-referenced applications are incorporated herein by reference in their entireties.

### BACKGROUND

[0002] Tissue ablation may be used to treat a variety of clinical disorders. For example, tissue ablation may be used to treat cardiac arrhythmias by at least partially destroying (e.g., at least partially or completely ablating, interrupting, inhibiting, terminating conduction of, otherwise affecting, etc.) aberrant pathways that would otherwise conduct abnormal electrical signals to the heart muscle. Several ablation techniques have been developed, including cryoablation, microwave ablation, radio frequency (RF) ablation, and high frequency ultrasound ablation. For cardiac applications, such techniques are typically performed by a clinician who introduces a catheter having an ablative tip to the endocardium via the venous vasculature, positions the ablative tip adjacent to what the clinician believes to be an appropriate region of the endocardium based on tactile feedback, mapping electrocardiogram (ECG) signals, anatomy, and/or fluoroscopic imaging, actuates flow of an irrigant to cool the surface of the selected region, and then actuates the ablative tip for a period of time and at a power believed sufficient to destroy tissue in the selected region.

[0003] Successful electrophysiology procedures require precise knowledge about the anatomic substrate. Additionally, ablation procedures may be evaluated within a short period of time after their completion. Cardiac ablation catheters typically carry only regular mapping electrodes. Cardiac ablation catheters may incorporate high-resolution mapping electrodes. Such high-resolution mapping electrodes provide more accurate and more detailed information about the anatomic substrate and about the outcome of ablation procedures. High-resolution mapping electrodes can allow the electrophysiology to evaluate precisely the morphology of electrograms, their amplitude and width and to determine changes in pacing thresholds. Morphology, amplitude and pacing threshold are accepted and reliable electrophysiology (EP) markers that provide useful information about the outcome of ablation.

### SUMMARY

[0004] According to some embodiments, a device for ablation and high-resolution of cardiac tissue comprises an elongate body (e.g., catheter, other medical instrument, etc.) comprising a distal end and an electrode assembly posi-

tioned along the distal end of the elongate body, wherein the electrode assembly comprises a first electrode portion, at least a second electrode portion positioned adjacent the first electrode portion, the first electrode portion and the second electrode portion being configured to contact tissue of a subject and deliver radiofrequency energy sufficient to at least partially ablate the tissue, at least one electrically insulating gap positioned between the first electrode portion and the second electrode portion, the at least one electrically insulating gap comprising a gap width separating the first and second electrode portions, and at least one separator positioned within the at least one electrically insulating gap, wherein the at least one separator contacts a proximal end of the first electrode portion and the distal end of the second electrode portion. The device additionally comprises at least one conductor configured to electrically couple an energy delivery module to at least one of the first and second electrode portions, wherein the at least one conductor is electrically coupled to an energy delivery module and wherein a frequency of energy provided to the first and second electrodes is in the radiofrequency range.

[0005] According to some embodiments, the device further comprises a filtering element electrically coupling the first electrode portion to the second electrode portion and configured to present a low impedance at a frequency used for delivering ablative energy via the first and second electrode portions, wherein the filtering element comprises a capacitor, wherein the capacitor comprises a capacitance of 50 to 300 nF (e.g., 100 nF, 50-100, 100-150, 150-200, 200-250, 250-300 nF, values between the foregoing ranges, etc.), wherein the elongate body comprises at least one irrigation passage, said at least one irrigation passage extending to the first electrode portion, wherein the first electrode portion comprises at least one outlet port in fluid communication with the at least one irrigation passage, wherein the gap width is approximately 0.2 to 1.0 mm (e.g., 0.2, 0.2-0.3, 0.3-0.4, 0.4-0.5, 0.5-0.6, 0.6-0.7, 0.7-0.8, 0.8-0.9, 0.9-1.0 mm, values between the foregoing ranges, less than 0.2 mm, greater than 1 mm, etc.), wherein a series impedance of lower than about 3 ohms ( $\Omega$ ) (e.g., e.g., 0-1, 1-2, 2-3 ohms, values between the foregoing ranges, etc.) is introduced across the first and second electrode portions in the operating RF frequency range, and wherein the operating RF frequency range is 200 kHz to 10 MHz (e.g., 200-300, 300-400, 400-500, 500-600, 600-700, 700-800, 800-900, 900-1000 kHz, up to 10 MHz or higher frequencies between the foregoing ranges, etc.). Electrode portions or sections can be used interchangeably with electrodes herein.

[0006] According to some embodiments, the device further comprises a first plurality of temperature-measurement devices positioned within separate apertures formed in a distal end of the electrode assembly, the first plurality of temperature-measurement devices (e.g., thermocouples, other temperature sensors, etc.) being thermally insulated from the electrode assembly, and a second plurality of temperature-measurement devices (e.g., thermocouples, other temperature sensors, etc.) positioned within separate apertures located in relation to the proximal end of the electrode assembly, the second plurality of temperature-measurement devices being thermally insulated from the electrode assembly, wherein temperature measurements determined from the first plurality of temperature-measurement devices and the second plurality of temperature-measurement devices facilitate determination of orientation of

the electrode assembly with respect to tissue being treated, and at least one thermal shunt member placing a heat absorption element in thermal communication with the electrode assembly to selectively remove heat from at least one of the electrode assembly and tissue being treated by the electrode assembly when the electrode assembly is activated, a contact sensing subsystem comprising a signal source configured to deliver a range of frequencies to the electrode assembly, and a processing device configured to obtain impedance measurements while different frequencies within the range of frequencies are being applied to the electrode assembly by the signal source, process the impedance measurements obtained at the different frequencies, and determine whether the electrode assembly is in contact with tissue based on said processing of the impedance measurements, wherein the elongate body comprises at least one irrigation passage, said at least one irrigation passage extending to the first electrode portion.

**[0007]** According to some embodiments, the device further comprises a first plurality of temperature-measurement devices (e.g., thermocouples, other temperature sensors, etc.) positioned within separate apertures formed in a distal end of the electrode assembly, the first plurality of temperature-measurement devices being thermally insulated from the electrode assembly, and a second plurality of temperature-measurement devices (e.g., thermocouples, other temperature sensors, etc.) positioned within separate apertures located in relation to the proximal end of the electrode assembly, the second plurality of temperature-measurement devices being thermally insulated from the electrode assembly, wherein temperature measurements determined from the first plurality of temperature-measurement devices and the second plurality of temperature-measurement devices facilitate determination of orientation of the electrode assembly with respect to tissue being treated.

**[0008]** According to some embodiments, the device further comprises at least one thermal shunt member placing a heat absorption element in thermal communication with the electrode assembly to selectively remove heat from at least one of the electrode assembly and tissue being treated by the electrode assembly when the electrode assembly is activated.

**[0009]** According to some embodiments, the device further comprises a contact sensing subsystem comprising a signal source configured to deliver a range of frequencies to the electrode assembly, and a processing device configured to obtain impedance measurements while different frequencies within the range of frequencies are being applied to the electrode assembly by the signal source, process the impedance measurements obtained at the different frequencies, and determine whether the electrode assembly is in contact with tissue based on said processing of the impedance measurements.

**[0010]** According to some embodiments, the filtering element comprises a capacitor. In some embodiments, the capacitor comprises a capacitance of 50 to 300 nF (e.g., 100 nF, 50-100, 100-150, 150-200, 200-250, 250-300 nF, values between the foregoing ranges, etc.).

**[0011]** According to some embodiments, the at least one thermal shunt member is in thermal communication with at least one fluid conduit (e.g., internal passageway) extending at least partially through an interior of the elongate body, the at least one fluid conduit being configured to place the electrode in fluid communication with a fluid source to

selectively remove heat from the electrode assembly and/or tissue of a subject located adjacent the electrode assembly.

**[0012]** According to some embodiments, the at least one thermal shunt member comprises a thermal diffusivity greater than 1.5 cm<sup>2</sup>/sec. In some embodiments, the at least one thermal shunt member comprises diamond (e.g., industrial-grade diamond).

**[0013]** According to some embodiments, the second plurality of temperature-measurement devices is positioned along a plane that is substantially perpendicular to a longitudinal axis of the distal end of the elongate body and spaced proximal to the first plurality of temperature-measurement devices. In some embodiments, each of the temperature-measurement devices comprises a thermocouple, a thermistor and/or any other type of temperature sensor or temperature measuring device or component. In some embodiments, the first plurality of temperature-measurement devices comprises at least three (e.g., 3, 4, 5, 6, more than 6, etc.) temperature sensors, and wherein the second plurality of temperature-measurement devices comprises at least three (e.g., 3, 4, 5, 6, more than 6, etc.) temperature sensors.

**[0014]** According to some embodiments, the device further comprises a means for facilitating high-resolution mapping. In some embodiments, electrically separating the first and second electrode portions facilitates high-resolution mapping along a targeted anatomical area. In some embodiments, the device further comprises at least one separator positioned within the at least one electrically insulating gap. In one embodiment, the at least one separator contacts a proximal end of the first electrode and the distal end of the second electrode portion.

**[0015]** According to some embodiments, the device further comprises at least one conductor configured to electrically couple an energy delivery module to at least one of the first and second electrodes. In some embodiments, the at least one conductor is electrically coupled to an energy delivery module.

**[0016]** According to some embodiments, a frequency of energy provided to the first and second electrodes is in the radiofrequency range. In some embodiments, a series impedance introduced across the first and second electrodes is lower than: (i) an impedance of a conductor that electrically couples the electrodes to an energy delivery module, and (ii) an impedance of a tissue being treated. In some embodiments, the gap width is approximately 0.2 to 1.0 mm (e.g., 0.5 mm, 0.2-0.3, 0.3-0.4, 0.4-0.5, 0.5-0.6, 0.6-0.7, 0.7-0.8, 0.8-0.9, 0.9-1.0 mm, values between the foregoing ranges, less than 0.2 mm, greater than 1 mm, etc.). In some embodiments, the elongate body (e.g., catheter) comprises at least one irrigation passage, said at least one irrigation passage extending to the first electrode.

**[0017]** According to some embodiments, the at least a second electrode comprises a second electrode and a third electrode portion, the second electrode portion positioned axially between the first and third electrode portions, wherein an electrically insulating gap separates the second and third electrode portions. In some embodiments, gaps are included between the first and second electrode portions and between the second and third electrode portions to increase a ratio of mapped tissue surface to ablated tissue surface. In some embodiments, the ratio is between 0.2 and 0.8 (e.g., 0.2-0.3, 0.3-0.4, 0.4-0.5, 0.5-0.6, 0.6-0.7, 0.7-0.8, ratios between the foregoing, etc.). In some embodiments, the

device further comprises a separator positioned within the gap between the second and third electrode portions.

**[0018]** According to some embodiments, a device for mapping and ablating tissue comprises an elongate body (e.g., a catheter, other medical instrument, etc.) including a proximal end and a distal end, a first electrode (or electrode portion or section) positioned on the elongate body, at least a second electrode (or electrode portion or section) positioned adjacent the first electrode, the first electrode (or electrode portion or section) and the second electrode (or electrode portion or section) being configured to contact tissue of a subject and deliver radiofrequency energy sufficient to at least partially ablate the tissue, at least one electrically insulating gap positioned between the first electrode (or electrode portion or section) and the second electrode (or electrode portion or section), the at least one electrically insulating gap comprising a gap width separating the first and second electrodes (or electrode portions or sections), and a filtering element electrically coupling the first electrode (or electrode portion or section) to the second electrode (or electrode portion or section) and configured to present a low impedance at a frequency used for delivering ablative energy via the first and second electrodes (or electrode portions or sections).

**[0019]** According to some embodiments, the device further comprises a means for facilitating high-resolution mapping. In some embodiments, electrically separating the first and second electrodes (or electrode portions or sections) facilitates high-resolution mapping along a targeted anatomical area (e.g., cardiac tissue). In some embodiments, the device further comprises at least one separator positioned within the at least one electrically insulating gap. In one embodiment, the at least one separator contacts a proximal end of the first electrode (or electrode portion or section) and the distal end of the second electrode (or electrode portion or section). In some embodiments, the device further comprises at least one conductor configured to electrically couple an energy delivery module to at least one of the first and second electrodes (or electrode portions or sections). In some embodiments, the at least one conductor is electrically coupled to an energy delivery module.

**[0020]** According to some embodiments, a frequency of energy provided to the first and second electrodes is in the radiofrequency range. In some embodiments, the filtering element comprises a capacitor. In some embodiments, the capacitor comprises a capacitance of 50 to 300 nF (e.g., 100 nF, 50-100, 100-150, 150-200, 200-250, 250-300 nF, values between the foregoing ranges, etc.). In some embodiments, the capacitor comprises a capacitance of 100 nF. In some embodiments, a series impedance of lower than about 3 ohms ( $\Omega$ ) (e.g., e.g., 0-1, 1-2, 2-3 ohms, values between the foregoing ranges, etc.) is introduced across the first and second electrodes in the operating RF frequency range. In some embodiments, the operating RF frequency range is 200 kHz to 10 MHz (e.g., 200-300, 300-400, 400-500, 500-600, 600-700, 700-800, 800-900, 900-1000 kHz, up to 10 MHz or higher frequencies between the foregoing ranges, etc.).

**[0021]** According to some embodiments, a series impedance introduced across the first and second electrodes is lower than: (i) an impedance of a conductor that electrically couples the electrodes to an energy delivery module, and (ii) an impedance of a tissue being treated. In some embodiments, the gap width is approximately 0.2 to 1.0 mm (e.g., 0.2, 0.2-0.3, 0.3-0.4, 0.4-0.5, 0.5-0.6, 0.6-0.7, 0.7-0.8, 0.8-

0.9, 0.9-1.0 mm, values between the foregoing ranges, less than 0.2 mm, greater than 1 mm, etc.). In some embodiments, the gap width is 0.5 mm.

**[0022]** According to some embodiments, the elongate body comprises at least one irrigation passage, the at least one irrigation passage extending to the first electrode. In some embodiments, the first electrode (or electrode portion or section) comprises at least one outlet port in fluid communication with the at least one irrigation passage.

**[0023]** According to some embodiments, the at least a second electrode (or electrode portion or section) comprises a second electrode (or electrode portion or section) and a third electrode (or electrode portion or section), the second electrode (or electrode portion or section) being positioned axially between the first and third electrodes (or electrode portions or sections), wherein an electrically insulating gap separates the second and third electrodes (or electrode portions or sections). In some embodiments, gaps are included between the first and second electrodes (or electrode portions or sections) and between the second and third electrodes (or electrode portions or sections) to increase a ratio of mapped tissue surface to ablated tissue surface. In some embodiments, the ratio is between 0.2 and 0.8 (e.g., 0.2-0.3, 0.3-0.4, 0.4-0.5, 0.5-0.6, 0.6-0.7, 0.7-0.8, ratios between the foregoing, etc.). In some embodiments, the device further comprising a separator positioned within the gap between the second and third electrodes (or electrode portions or sections).

**[0024]** According to some embodiments, an ablation device comprises a first electrode (or electrode portion or section) positioned at a distal end of a catheter, at least a second electrode (or electrode portion or section) positioned at a location proximal to the first electrode (or electrode portion or section), the first electrode (or electrode portion or section) and the second electrode (or electrode portion or section) being configured to contact tissue (e.g., cardiac tissue, other targeted anatomical tissue, etc.) of a subject and deliver energy sufficient to at least partially ablate the tissue, an electrically insulating gap positioned between the first electrode (or electrode portion or section) and the second electrode (or electrode portion or section), the electrically insulating gap comprising a gap width separating the first and second electrodes (or electrode portions or sections), and a filtering element electrically coupling the first electrode (or electrode portion or section) to the second electrode (or electrode portion or section).

**[0025]** According to some embodiments, electrically separating the first and second electrodes (or electrode portions or sections) facilitates high-resolution mapping along a targeted anatomical area. In some embodiments, the device further comprises at least one separator positioned within the at least one electrically insulating gap. In several embodiments, the at least one separator contacts a proximal end of the first electrode (or electrode portion or section) and the distal end of the second electrode (or electrode portion or section).

**[0026]** According to some embodiments, the device additionally comprises at least one conductor configured to energize at least one of the first and second electrodes (or electrode portions or sections). In one embodiment, the at least one conductor is electrically coupled to an energy delivery module (e.g., a RF generator).

**[0027]** According to some embodiments, the device further comprises means for connectivity to an electrophysiol-

ogy recorder. In some embodiments, the device is configured to connect to an electrophysiology recorder.

**[0028]** According to some embodiments, a frequency of energy provided to the first and second electrodes is in the radiofrequency (RF) range. In some embodiments, the operating RF frequency range is 200 kHz to 10 MHz (e.g., 200-300, 300-400, 400-500, 500-600, 600-700, 700-800, 800-900, 900-1000 kHz, up to 10 MHz or higher frequencies between the foregoing ranges, etc.). In some embodiments, the filtering element comprises a capacitor. In some embodiments, the capacitor comprises a capacitance of 50 to 300 nF (e.g., 100 nF, 50-100, 100-150, 150-200, 200-250, 250-300 nF, values between the foregoing ranges, etc.). In some embodiments, a series impedance of less than 3 ohms ( $\Omega$ ) (e.g., e.g., 0-1, 1-2, 2-3 ohms, values between the foregoing ranges, etc.) is introduced across the first and second electrodes (or electrode portions or sections) at 500 kHz.

**[0029]** According to some embodiments, a series impedance introduced across the first and second electrodes is lower than: (i) an impedance of a conductor that electrically couples the electrodes to an energy delivery module, and (ii) an impedance of a tissue being treated. In some embodiments, the gap width is approximately 0.2 to 1.0 mm (e.g., 0.2, 0.2-0.3, 0.3-0.4, 0.4-0.5, 0.5-0.6, 0.6-0.7, 0.7-0.8, 0.8-0.9, 0.9-1.0 mm, values between the foregoing ranges, less than 0.2 mm, greater than 1 mm, etc.). In one embodiment, the gap width is 0.5 mm.

**[0030]** According to some embodiments, the at least a second electrode (or electrode portion or section) comprises a second electrode (or electrode portion or section) and a third electrode (or electrode portion or section), the second electrode (or electrode portion or section) being positioned axially between the first and third electrodes (or electrode portions or sections), wherein an electrically insulating gap separates the second and third electrodes (or electrode portions or sections). In some embodiments, the a separator is positioned within the gap between the second and third electrodes (or electrode portions or sections). In some embodiments, gaps are included between the first and second electrodes (or electrode portions or sections) and between the second and third electrodes (or electrode portions or sections) to increase a ratio of mapped tissue surface to ablated tissue surface. In some embodiments, the ratio is between 0.2 and 0.8 (e.g., 0.2-0.3, 0.3-0.4, 0.4-0.5, 0.5-0.6, 0.6-0.7, 0.7-0.8, ratios between the foregoing, etc.).

**[0031]** According to some embodiments, the system further comprises means for connectivity to an electrophysiology recorder. In some embodiments, the system is configured to connect to an electrophysiology recorder. In some embodiments, the system comprises an ablation device, and at least one of (i) a generator for selectively energizing the device, and (ii) an electrophysiology recorder.

**[0032]** According to some embodiments, a method of delivering energy to an ablation device comprises energizing a split tip or split section electrode positioned on a catheter (or other medical instrument), the split tip or split section electrode comprising a first electrode and a second electrode (or electrode portions or sections), the first electrode and the second electrode being configured to contact tissue of a subject and deliver energy sufficient to at least partially ablate the tissue, wherein an electrically insulating gap is positioned between the first electrode and the second electrode, the electrically insulating gap comprising a gap width separating the first and second electrodes, wherein a filtering

element electrically couples the first electrode to the second electrode, and wherein electrically separating the first and second electrodes facilitates high-resolution mapping along a targeted anatomical area.

**[0033]** According to some embodiments, the method additionally includes receiving high-resolution mapping data from the first and second electrodes (or electrode portions or sections), the high-resolution mapping data relating to tissue of a subject adjacent the first and second electrodes (or electrode portions or sections). In some embodiments, receiving high-resolution mapping data occurs prior to, during or after energizing a split tip electrode positioned on a catheter.

**[0034]** According to some embodiments, a method of mapping tissue of a subject includes receiving high-resolution mapping data using a split-tip or split-section electrode, said split-tip or split-section electrode comprising first and second electrodes positioning a split-section electrode located on a catheter, the split-tip or split-section electrode comprising a first electrode and a second electrode separated by an electrically insulating gap, wherein a filtering element electrically couples the first electrode to the second electrode in the operating RF range, and wherein electrically insulating the first and second electrodes facilitates high-resolution mapping along a targeted anatomical area.

**[0035]** According to some embodiments, the method additionally includes energizing at least one of the first and second electrodes to deliver energy sufficient to at least partially ablate the tissue of the subject. In some embodiments, the high-resolution mapping data relates to tissue of a subject adjacent the first and second electrodes. In some embodiments, receiving high-resolution mapping data occurs prior to, during or after energizing a split tip or a split section electrode positioned on a catheter.

**[0036]** According to some embodiments, a separator is positioned within the at least one electrically insulating gap. In some embodiments, the at least one separator contacts a proximal end of the first electrode and the distal end of the second electrode. In some embodiments, the first and second electrodes are selectively energized using at least one conductor electrically coupled to an energy delivery module. In some embodiments, the mapping data is provided to an electrophysiology recorder.

**[0037]** According to some embodiments, a frequency of energy provided to the first and second electrodes is in the radiofrequency (RF) range. In some embodiments, the filtering element comprises a capacitor.

**[0038]** According to some embodiments, a frequency of energy provided to the first and second electrodes is in the radiofrequency (RF) range. In some embodiments, the operating RF frequency range is 200 kHz to 10 MHz (e.g., 200-300, 300-400, 400-500, 500-600, 600-700, 700-800, 800-900, 900-1000 kHz, up to 10 MHz or higher frequencies between the foregoing ranges, etc.). In some embodiments, the filtering element comprises a capacitor. In some embodiments, the capacitor comprises a capacitance of 50 to 300 nF (e.g., 100 nF, 50-100, 100-150, 150-200, 200-250, 250-300 nF, values between the foregoing ranges, etc.). In some embodiments, a series impedance of less than 3 ohms ( $\Omega$ ) (e.g., e.g., 0-1, 1-2, 2-3 ohms, values between the foregoing ranges, etc.) is introduced across the first and second electrodes (or electrode portions or sections) at 500 kHz.

**[0039]** According to some embodiments, a series impedance introduced across the first and second electrodes is

lower than: (i) an impedance of a conductor that electrically couples the electrodes to an energy delivery module, and (ii) an impedance of a tissue being treated. In some embodiments, the gap width is approximately 0.2 to 1.0 mm (e.g., 0.2, 0.2-0.3, 0.3-0.4, 0.4-0.5, 0.5-0.6, 0.6-0.7, 0.7-0.8, 0.8-0.9, 0.9-1.0 mm, values between the foregoing ranges, less than 0.2 mm, greater than 1 mm, etc.). In one embodiment, the gap width is 0.5 mm.

**[0040]** According to some embodiments, a kit for ablation and high-resolution mapping of cardiac tissue, comprising a device for high-resolution mapping, the device further being configured to provide ablative energy to targeted tissue, the device comprising an elongate body (e.g., catheter, other medical instrument, etc.) comprising a proximal end and a distal end, the elongate body comprising an electrode assembly, the electrode assembly comprising a first and second high-resolution portions, the first high-resolution electrode portion positioned on the elongate body, the second electrode portion being positioned adjacent the first electrode portion, the first and second electrode portions being configured to contact tissue of a subject, and at least one electrically insulating gap positioned between the first electrode portion and the second electrode portion, the at least one electrically insulating gap comprising a gap width separating the first and second electrode portions, wherein the first electrode portion is configured to electrically couple to the second electrode portion using a filtering element, wherein the filtering element is configured to present a low impedance at a frequency used for delivering ablative energy via the first and second electrode portions, and wherein the device is configured to be positioned within targeted tissue of the subject to obtain high-resolution mapping data related to said tissue when ablative energy is not delivered to the first and second electrode portions. The kit further comprises an energy delivery module configured to generate energy for delivery to the electrode assembly, and a processor configured to regulate the delivery of energy from the energy delivery module to the electrode assembly.

**[0041]** According to some embodiments, a kit for ablation and high-resolution mapping of cardiac tissue comprises an ablation device, an energy delivery module (e.g., a generator) configured to generate energy for delivery to the electrode assembly, and a processor configured to regulate the delivery of energy from the energy delivery module to the electrode assembly. In some embodiments, the energy delivery module comprises a RF generator. In some embodiments, the energy delivery module is configured to couple to the device.

**[0042]** According to some embodiments, a generator for selectively delivering energy to an ablation device comprises an energy delivery module configured to generate ablative energy for delivery to an ablation device, and a processor configured to regulate the delivery of energy from the energy delivery module to the ablation device.

**[0043]** According to some embodiments, an ablation device comprises an elongate body (e.g., catheter, other medical instrument, etc.) comprising a distal end, an electrode positioned at the distal end of the elongate body, and at least one thermal shunt member placing a heat absorption element in thermal communication with the electrode to selectively remove heat from at least one of the electrode and tissue being treated by the electrode when the electrode is activated, wherein the at least one thermal shunt member

extends at least partially through an interior of the electrode to dissipate and remove heat from the electrode during use.

**[0044]** According to some embodiments, the at least one thermal shunt member is in thermal communication with at least one fluid conduit extending at least partially through an interior of the elongate body, the at least one fluid conduit being configured to place the electrode in fluid communication with a fluid source to selectively remove heat from the electrode and/or tissue of a subject located adjacent the electrode. In some embodiments, a fluid conduit or passage extends at least partially through an interior of the elongate body. In some embodiments, the fluid conduit or passage extends at least partially through the at least one thermal shunt member. In several configurations, the at least one thermal shunt member is at least partially in thermal communication with a thermally convective fluid. In some embodiments,

**[0045]** a flow rate of the thermally convective fluid is less than 15 ml/min in order to maintain a desired temperature along the electrode during an ablation procedure. In some embodiments, a flow rate of the thermally convective fluid is approximately less than 10 ml/min in order to maintain a desired temperature along the electrode during an ablation procedure. In some embodiments, a flow rate of the thermally convective fluid is approximately less than 5 ml/min in order to maintain a desired temperature along the electrode during an ablation procedure. In some embodiments, the desired temperature along the electrode during an ablation procedure is 60 degrees C. In some embodiments, the thermally convective fluid comprises blood and/or another bodily fluid.

**[0046]** According to some embodiments, the at least one fluid conduit is in direct thermal communication with the at least one thermal shunt member. In some embodiments, the at least one fluid conduit is not in direct thermal communication with the at least one thermal shunt member. In some embodiments, the at least one fluid conduit comprises at least one opening, wherein the at least one opening places irrigation fluid passing through the at least one fluid conduit in direct physical contact with at least a portion of the at least one thermal shunt member. In some embodiments, the at least one opening is located along a perforated portion of the at least one conduit, wherein the perforated portion of the at least one conduit is located distally to the electrode. In some embodiments, the at least one fluid conduit is in fluid communication only with exit ports located along the distal end of the elongate body. In several configurations, the at least one fluid conduit directly contacts the at least one thermal shunt member. In some embodiments, the at least one fluid conduit does not contact the at least one thermal shunt member.

**[0047]** According to some embodiments, the at least one thermal shunt member comprises a thermal diffusivity greater than 1.5 cm<sup>2</sup>/sec. In some embodiments, the at least one thermal shunt member comprises diamond (e.g., an industrial-grade diamond). In other embodiments, the at least one thermal shunt member comprises a carbon-based material (e.g., Graphene, silica, etc.). In some embodiments, a temperature of the at least one thermal shunt member does not exceed 60 to 62 degrees Celsius while maintaining a desired temperature along the electrode during an ablation procedure. In some embodiments, the desired temperature along the electrode during an ablation procedure is 60 degrees C.

**[0048]** According to some embodiments, the electrode comprises a radiofrequency (RF) electrode. In some embodiments, the electrode comprises a split-tip electrode. In several configurations, the split-tip electrode comprises a first electrode portion and at least a second electrode portion, wherein an electrically insulating gap is located between the first electrode portion and the at least a second electrode portion to facilitate high-resolution mapping along a targeted anatomical area.

**[0049]** According to some embodiments, at least a portion of the at least one thermal shunt member extends to an exterior of the catheter adjacent the proximal end of the electrode. In some embodiments, at least a portion of the at least one thermal shunt member extends to an exterior of the catheter adjacent the distal end of the electrode. In some embodiments, at least a portion of the at least one thermal shunt member extends proximally relative to the proximal end of the electrode. In some embodiments, the at least one thermal shunt member comprises a disk or other cylindrically-shaped member. In some embodiments, the at least one thermal shunt member comprises at least one extension member extending outwardly from a base member.

**[0050]** According to some embodiments, the at least one fluid conduit comprises at least one fluid delivery conduit and at least one fluid return conduit, wherein the fluid is at least partially circulated through an interior of the elongate body via the at least one fluid delivery conduit and the at least one fluid return conduit, wherein the at least one fluid conduit is part of a closed-loop or non-open cooling system. In some embodiments, the elongate body comprises a cooling chamber along a distal end of the elongate body, wherein the cooling chamber is configured to be in fluid communication with the at least one fluid conduit. In some embodiments, the at least one fluid conduit comprises a metallic material, an alloy and/or the like. In some embodiments, the elongate body does not comprise a fluid conduit. In some embodiments, an interior of a distal end of the elongate body comprises an interior member generally along a location of the electrode. In some embodiments, the interior member comprises at least one thermally conductive material configured to dissipate and/or transfer heat generated by the electrode.

**[0051]** According to some embodiments, an ablation device comprises an elongate body (e.g., catheter, other medical instrument, etc.) including a distal end, an ablation member positioned at the distal end of the elongate body, and at least one thermal shunt member placing a heat shunting element in thermal communication with the electrode to selectively remove heat from at least a portion of the electrode and/or tissue being treated by the electrode when the electrode is activated, wherein the heat shunting element of the at least one thermal shunt extends at least partially through an interior of the ablation member to help remove and dissipate heat generated by the ablation member during use.

**[0052]** According to several embodiments, the at least one thermal shunt member is in thermal communication with at least one fluid conduit or passage extending at least partially through an interior of the elongate body, the at least one fluid conduit or passage being configured to place the ablation member in fluid communication with a fluid source to selectively remove heat from the ablation member and/or tissue of a subject located adjacent the ablation member. In some embodiments, the at least one thermal shunt member

comprises at least one fluid conduit or passage extending at least partially through an interior of the elongate body. In some embodiments, the at least one thermal shunt member does not comprise a fluid conduit or passage extending at least partially through an interior of the elongate body. In some embodiments, an interior of the distal end of the elongate body comprises an interior member generally along a location of the ablation member. In several configurations, the interior member comprises at least one thermally conductive material configured to dissipate and/or transfer heat generated by the ablation member.

**[0053]** According to some embodiments, the ablation member comprises a radiofrequency (RF) electrode. In some embodiments, the ablation member comprises one of a microwave emitter, an ultrasound transducer and a cryoablation member.

**[0054]** According to some embodiments, the at least one thermal shunt member comprises a thermal diffusivity greater than 1.5 cm<sup>2</sup>/sec (e.g., greater than 1.5 cm<sup>2</sup>/sec or 5 cm<sup>2</sup>/sec (e.g., 1.5-2, 2-2.5, 2.5-3, 3-4, 4-5, 5-6, 6-7, 7-8, 8-9, 9-10, 10-11, 11-12, 12-13, 13-14, 14-15, 15-20 cm<sup>2</sup>/sec, values between the foregoing ranges, greater than 20 cm<sup>2</sup>/sec). In some arrangements, the at least one thermal shunt member comprises a thermal diffusivity greater than 5 cm<sup>2</sup>/sec. In some embodiments, the at least one thermal shunt member comprises a diamond (e.g., an industrial-grade diamond). In some embodiments, the at least one thermal shunt member comprises a carbon-based material (e.g., Graphene, silica, etc.). In some embodiments, the radiofrequency (RF) electrode comprises a split-tip RF electrode or other high-resolution electrode.

**[0055]** According to some embodiments, the at least one fluid conduit or passage is in direct thermal communication with the at least one thermal shunt member. In some embodiments, the at least one irrigation conduit is not in direct thermal communication with the at least one thermal shunt member. In some arrangements, the at least one fluid conduit or passage directly contacts the at least one thermal shunt member. In some embodiments, the at least one fluid conduit or passage does not contact the at least one thermal shunt member. In some embodiments, the at least one fluid conduit or passage comprises at least one opening, wherein the at least one opening places irrigation fluid passing through the at least one fluid conduit or passage in direct physical contact with at least a portion of the at least one thermal shunt member. In some embodiments, the at least one opening is located along a perforated portion of the at least one conduit or passage, wherein the perforated portion of the at least one conduit or passage is located distally to the electrode.

**[0056]** According to some embodiments, at least a portion of the at least one thermal shunt member extends to an exterior of the catheter adjacent the proximal end of the ablation member. In some embodiments, at least a portion of the at least one thermal shunt member extends to an exterior of the catheter adjacent the distal end of the ablation member. In some embodiments, at least a portion of the at least one thermal shunt member extends proximally relative to the proximal end of the ablation member. In some embodiments, the at least one thermal shunt member comprises a disk or other cylindrically-shaped member. In several configurations, the at least one thermal shunt member comprises at least one extension member extending outwardly from a base member. In some embodiments, the at

least one extension member comprises at least one of a fin, a pin or a wing. In some embodiments, the at least one fluid conduit or passage comprises a metallic material.

**[0057]** According to some embodiments, a method of heat removal from an ablation member during a tissue treatment procedure includes activating an ablation system, the system comprising an elongate body (e.g., catheter, other medical instrument, etc.) comprising a distal end, an ablation member positioned at the distal end of the elongate body, wherein the elongate body of the ablation system comprises at least one thermal shunt member along its distal end, wherein the at least one thermal shunt member extends at least partially through an interior of the ablation member, and at least partially removing heat generated by the ablation member along the distal end of the elongate body via the at least one thermal shunt member so as to reduce the likelihood of localized hot spots along the distal end of the elongate body.

**[0058]** According to some embodiments, the elongate body further comprises at least one fluid conduit or passage extending at least partially through an interior of the elongate body, wherein the method further comprises delivering fluid through the at least one fluid conduit or passage, wherein the at least one thermal shunt member places the at least one fluid conduit or passage in thermal communication with a proximal portion of the ablation member to selectively remove heat from the proximal portion of the ablation member when the electrode is activated, wherein the at least one fluid conduit or passage is configured to place the ablation member in fluid communication with a fluid source to selectively remove heat from the ablation member and/or tissue of a subject located adjacent the ablation member.

**[0059]** According to some embodiments, the elongate body is advanced to a target anatomical location of the subject through a bodily lumen of the subject. In some embodiments, the bodily lumen of the subject comprises a blood vessel, an airway or another lumen of the respiratory tract, a lumen of the digestive tract, a urinary lumen or another bodily lumen. In some embodiments, the ablation member comprises a radiofrequency (RF) electrode. In other arrangements, the ablation member comprises one of a microwave emitter, an ultrasound transducer and a cryoablation member.

**[0060]** According to some embodiments, the at least one thermal shunt member comprises a thermal diffusivity greater than  $1.5 \text{ cm}^2/\text{sec}$  (e.g., greater than  $1.5 \text{ cm}^2/\text{sec}$  or  $5 \text{ cm}^2/\text{sec}$  (e.g., 1.5-2, 2-2.5, 2.5-3, 3-4, 4-5, 5-6, 6-7, 7-8, 8-9, 9-10, 10-11, 11-12, 12-13, 13-14, 14-15, 15-20  $\text{cm}^2/\text{sec}$ , values between the foregoing ranges, greater than  $20 \text{ cm}^2/\text{sec}$ ). In some arrangements, the at least one thermal shunt member comprises a thermal diffusivity greater than  $5 \text{ cm}^2/\text{sec}$ . In some embodiments, the at least one thermal shunt member comprises a diamond (e.g., an industrial-grade diamond). In some embodiments, the at least one thermal shunt member comprises a carbon-based material (e.g., Graphene, silica, etc.). In some embodiments, the radiofrequency (RF) electrode comprises a split-tip RF electrode or other high-resolution electrode. In some embodiments, the method additionally includes obtaining at least one high-resolution image of the target anatomical locations of the subject adjacent the ablation member.

**[0061]** According to some embodiments, the at least one fluid conduit or passage is in direct thermal communication with the at least one thermal shunt member. In some embodiments, the at least one irrigation conduit is not in

direct thermal communication with the at least one thermal shunt member. According to some embodiments, the at least one fluid conduit or passage directly contacts the at least one thermal shunt member. In some embodiments, the at least one fluid conduit or passage does not contact the at least one thermal shunt member. In some embodiments, delivering fluid through the at least one fluid conduit or passage comprises delivering fluid to and through the distal end of the catheter in an open irrigation system. In several configurations, delivering fluid through the at least one fluid conduit or passage includes circulating fluid through the distal end of the catheter adjacent the ablation member in a closed fluid cooling system.

**[0062]** According to some embodiments, the elongate body of the ablation system does not comprise any fluid conduits or passages. In one embodiment, the elongate body comprises an interior member. In some embodiments, the interior member comprises a thermally conductive material that is in thermal communication with the at least one thermal shunt member to help dissipate and distribute heat generated by the ablation member during use. In some embodiments, at least a portion of the at least one thermal shunt member extends to an exterior of the catheter adjacent the proximal end of the ablation member. In some embodiments, at least a portion of the at least one thermal shunt member extends proximally to the proximal end of the ablation member. In some embodiments, at least a portion of the at least one thermal shunt member extends distally to the proximal end of the ablation member such that at least a portion of the at least one thermal shunt member is located along a length of the ablation member. In several configurations, the at least one thermal shunt member comprises a disk or other cylindrically-shaped member. In some arrangements, the at least one thermal shunt member comprises at least one extension member extending outwardly from a base member. In some embodiments, the at least one extension member comprises at least one of a fin, a pin, a wing and/or the like.

**[0063]** According to some embodiments, a system comprises means for connectivity to an electrophysiology recorder. In some embodiments, the system is configured to connect to an electrophysiology recorder. In some embodiments, the system further comprises at least one of (i) a generator for selectively energizing the device, and (ii) an electrophysiology recorder. In some embodiments, the system further comprises both (i) a generator for selectively energizing the device, and (ii) an electrophysiology recorder.

**[0064]** According to some embodiments, a system for delivering energy to targeted tissue of a subject includes a catheter having a high-resolution electrode (e.g., a split-tip electrode). The split-tip electrode can include two or more electrodes or electrode portions that are separated by an electrically-insulating gap. A filtering element can electrically couple the first and second electrodes or electrode portions, or any adjacent electrode sections (e.g., in a circumferential or radial arrangement) and can be configured to present a low impedance at a frequency used for delivering ablative energy via the first and second electrodes or electrode portions. In some embodiments, electrically separating the first and second electrodes, or electrode portions (e.g., in a circumferential or radial arrangement), facilitates high-resolution mapping along a targeted anatomical area. The catheter can further include a plurality of temperatures sensors (e.g., thermocouples) that are thermally insulated

from the electrode and are configured to detect tissue temperature at a depth. The catheter can also include one or more thermal shunt members and/or components for transferring heat away from the electrode and/or the tissue being treated. In some embodiments, such thermal shunt members and/or components include diamond (e.g., industrial diamond) and/or other materials with favorable thermal diffusivity characteristics. Further, the system can be configured to detect whether and to what extent contact has been achieved between the electrode and targeted tissue.

**[0065]** According to some embodiments, an energy delivery device (e.g., ablation device) comprises an elongate body (e.g., a catheter) comprising a proximal end and a distal end, a first electrode (e.g., radiofrequency electrode) positioned at the distal end of the elongate body, and one or more second electrodes (e.g., radiofrequency electrodes) positioned at a location proximal to the first electrode, the first electrode and the second electrode being configured to contact tissue of a subject and deliver radiofrequency energy sufficient to at least partially ablate the tissue. In alternative embodiments, the electrodes are distributed or otherwise located circumferentially around the catheter (e.g., along four quadrant sections distributed around the catheter shaft circumference separated by gaps). In other embodiments, the catheter may have additional support structures and may employ multiple electrodes distributed on the support structures. The device further comprises at least one electrically insulating gap positioned between the first electrode and the second electrode or the sections of circumferential electrodes, the at least one electrically insulating gap comprising a gap width separating the first and second electrodes, and a band-pass filtering element electrically coupling the first electrode to the second electrode, or any adjacent electrode sections (e.g., in a circumferential or radial arrangement), and configured to present a low impedance at a frequency used for delivering ablative energy via the first and second electrodes. In some embodiments, electrically separating the first and second electrodes, or electrode sections (e.g., in a circumferential or radial arrangement), facilitates high-resolution mapping along a targeted anatomical area. In some embodiments, the ratio of ablated tissue surface to that of mapped tissue is enhanced (e.g., optimized).

**[0066]** Several embodiments disclosed in the present application are particularly advantageous because they include one, more or all of the following benefits: a system configured to deliver energy (e.g., ablative or other type of energy) to anatomical tissue of a subject and configured for high-resolution mapping; a system configured to deliver energy to anatomical tissue of a subject and configured to detect the effectiveness of the resulting treatment procedure using its high-resolution mapping capabilities and functions; a split-tip or split-section design configured to be energized as a unitary tip or section to more uniformly provide energy to targeted anatomical tissue of a subject and/or the like.

**[0067]** According to some embodiments, the device further comprises a separator positioned within the at least one electrically insulating gap. In some embodiments, the at least one separator contacts a proximal end of the first electrode and the distal end of the second electrode. In some embodiments, the separator contacts, at least partially, a side of one electrode section and an opposing side of the adjacent electrode section. In one embodiment, the first and second electrodes and the separator are cylindrical. In one embodiment, the outer diameter of the electrodes and the separator

are equal. In some embodiments, the first and second electrodes include quadrants or other sections that are circumferentially distributed on the catheter shaft. In some embodiments, the first and second electrodes comprise other geometries that make suitable for distribution on a catheter shaft and also be separated by a narrow non-conductive gap. In some embodiments, the device further comprises at least one conductor (e.g., wire, cable, etc.) configured to electrically couple an energy delivery module (e.g., a RF or other generator) to at least one of the first and second electrodes. In some embodiments, the device further comprises one or more additional conductors connected to each of the first and second electrodes for distributing signals (e.g., cardiac signals) picked up by said electrodes to an electrophysiology (EP) recorder.

**[0068]** According to some embodiments, a device additionally includes an electrophysiology recorder. In some embodiments, a frequency of energy provided to the first and second electrodes is in an operating radiofrequency (RF) range (e.g., approximately 300 kHz to 10 MHz).

**[0069]** According to some embodiments, the band-pass filtering element comprises a capacitor. In some embodiments, the capacitor comprises a capacitance of 50 to 300 nF (e.g., 100 nF, 50-100, 100-150, 150-200, 200-250, 250-300 nF, values between the foregoing ranges, etc.), depending, e.g., on the operating frequency used to deliver ablative energy. In some embodiments, a series impedance of about 3 ohms ( $\Omega$ ) or less than about 3 ohms (e.g., 0-1, 1-2, 2-3 ohms, values between the foregoing ranges, etc.) is introduced between the first and second electrodes in the operating RF frequency range (e.g., 300 kHz to 10 MHz). For example, a lower capacitance value (e.g. 5-10 nF) may be used at a higher frequency range (e.g. 10 MHz). In some embodiments, a 100 nF capacitance value may be well-suited for applications in the 500 kHz frequency range. In some embodiments, a series impedance introduced across the first and second electrodes is lower than: (i) an impedance of a conductor that electrically couples the electrodes to an energy delivery module, and (ii) an impedance of a tissue being treated. In some embodiments, the device further comprises a band-pass filtering element electrically coupling the second electrode to the third electrode, or any adjacent electrode sections (e.g., in a circumferential or radial arrangement), and configured to present a low impedance at a frequency used for delivering ablative energy via the second and third electrodes.

**[0070]** According to some embodiments, the gap width between the first and second electrodes is approximately 0.2 to 1.0 mm (e.g., 0.5 mm). In some embodiments, the elongate body comprises at least one irrigation passage, said at least one irrigation passage extending to the first electrode. In one embodiment, the first electrode comprises at least one outlet port in fluid communication with the at least one irrigation passage.

**[0071]** According to some embodiments, the device further comprises a third electrode, wherein the second electrode is positioned axially between the first and third electrodes, wherein an electrically insulating gap separates the second and third electrodes. In some embodiments, the device further comprises a separator positioned within the gap between the second and third electrodes.

**[0072]** According to some embodiments, a system comprises an ablation device according to any of the embodiments disclosed herein. In some embodiments, the system

additionally comprises means for connectivity to an electrophysiology recorder. In some embodiments, the system is configured to connect to an electrophysiology recorder. In some embodiments, the system further comprises at least one of (i) a generator for selectively energizing the device, and (ii) an electrophysiology recorder.

**[0073]** According to some embodiments, a method of simultaneously delivering energy to an ablation device and mapping tissue of a subject comprises energizing a split-tip or split-section electrode being separated by a non-conductive gap from the first electrode and a second electrode, the second electrode positioned at a location proximal to the first electrode, the first electrode and the second electrode being configured to contact tissue of a subject to deliver energy sufficient to at least partially ablate the tissue and to receive high-resolution mapping data, the high-resolution mapping data relating to tissue of a subject adjacent the first and second electrodes. In some embodiments, an electrically insulating gap is positioned between the first electrode and the second electrode, the electrically insulating gap comprising a gap width separating the first and second electrodes. In some embodiments, a filtering element electrically couples the first electrode to the second electrode only in the operating RF frequency range. In one embodiment, electrically separating the first and second electrodes facilitates high-resolution mapping along a targeted anatomical area.

**[0074]** According to some embodiments, a separator is positioned within the at least one electrically insulating gap. In one embodiment, the at least one separator contacts a proximal end of the first electrode and the distal end of the second electrode.

**[0075]** According to some embodiments, the mapping data is provided to an electrophysiology recorder. In some embodiments, a frequency of energy provided to the first and second electrodes is in the radiofrequency range.

**[0076]** According to some embodiments, the filtering element comprises a capacitor. In one embodiment, the capacitor comprises a capacitance of 50 to 300 nF (e.g., 100 nF), depending on, e.g., the operating frequency used for ablative energy. In some embodiments, a series impedance of about 3 ohms ( $\Omega$ ) is introduced across the first and second electrodes at 500 kHz. In some embodiments, a series impedance introduced across the first and second electrodes is lower than: (i) an impedance of a conductor that electrically couples the electrodes to an energy delivery module, and (ii) an impedance of a tissue being treated.

**[0077]** According to some embodiments, the gap width is approximately 0.2 to 1.0 mm. In one embodiment, the gap width is 0.5 mm.

**[0078]** According to some embodiments, an ablation device comprises an elongate body (e.g., catheter, other medical instrument, etc.) comprising a distal end, an electrode positioned at the distal end of the elongate body and at least one thermal shunt member placing a heat absorption element in thermal communication with the electrode to selectively remove heat from at least one of the electrode and tissue being treated by the electrode when the electrode is activated, wherein the at least one thermal shunt member extends at least partially through an interior of the electrode to dissipate and remove heat from the electrode during use. In some embodiments, the at least one thermal shunt member is in thermal communication with at least one fluid conduit extending at least partially through an interior of the elongate body, the at least one fluid conduit being configured

to place the electrode in fluid communication with a fluid source to selectively remove heat from the electrode and/or tissue of a subject located adjacent the electrode. In some embodiments, a fluid conduit or passage extends at least partially through an interior of the elongate body. In one embodiment, the fluid conduit or passage extends at least partially through the at least one thermal shunt member. In some embodiments, the at least one thermal shunt member is at least partially in thermal communication with a thermally convective fluid. In some embodiments, the thermally convective fluid comprises blood and/or another bodily fluid.

**[0079]** According to some embodiments, a flow rate of the thermally convective fluid is less than 15 ml/min in order to maintain a desired temperature along the electrode during an ablation procedure. In some embodiments, a flow rate of the thermally convective fluid is approximately less than 10 ml/min in order to maintain a desired temperature along the electrode during an ablation procedure. In some embodiments, a flow rate of the thermally convective fluid is approximately less than 5 ml/min in order to maintain a desired temperature along the electrode during an ablation procedure. According to some embodiments, the desired temperature along the electrode during an ablation procedure is 60 degrees C.

**[0080]** According to some embodiments, the at least one thermal shunt member comprises a thermal diffusivity greater than 1.5 cm<sup>2</sup>/sec or 5 cm<sup>2</sup>/sec (e.g., 1.5-2, 2-2.5, 2.5-3, 3-4, 4-5, 5-6, 6-7, 7-8, 8-9, 9-10, 10-11, 11-12, 12-13, 13-14, 14-15, 15-20 cm<sup>2</sup>/sec, values between the foregoing ranges, greater than 20 cm<sup>2</sup>/sec). In some embodiments, the at least one thermal shunt member comprises diamond (e.g., an industrial-grade diamond). In some embodiments, the at least one thermal shunt member comprises a carbon-based material. In some embodiments, the at least one thermal shunt member comprises at least one of Graphene and silica.

**[0081]** According to some embodiments, a temperature of the at least one thermal shunt member does not exceed 60 to 62 degrees Celsius while maintaining a desired temperature along the electrode during an ablation procedure. In some embodiments, the desired temperature along the electrode during an ablation procedure is 60 degrees C.

**[0082]** According to some embodiments, the electrode comprises a radiofrequency (RF) electrode. In some embodiments, the electrode comprises a split-tip electrode. In some embodiments, the split-tip electrode comprises a first electrode portion and at least a second electrode portion, wherein an electrically insulating gap is located between the first electrode portion and the at least a second electrode portion to facilitate high-resolution mapping along a targeted anatomical area.

**[0083]** According to some embodiments, the at least one fluid conduit is in direct thermal communication with the at least one thermal shunt member. In some embodiments, the at least one fluid conduit is not in direct thermal communication with the at least one thermal shunt member. In some embodiments, the at least one fluid conduit comprises at least one opening, wherein the at least one opening places irrigation fluid passing through the at least one fluid conduit in direct physical contact with at least a portion of the at least one thermal shunt member. In some embodiments, the at least one opening is located along a perforated portion of the at least one conduit, wherein the perforated portion of the at least one conduit is located distally to the electrode. In one

embodiment, the at least one fluid conduit is in fluid communication only with exit ports located along the distal end of the elongate body. In some embodiments, the at least one fluid conduit directly contacts the at least one thermal shunt member. In some embodiments, the at least one fluid conduit does not contact the at least one thermal shunt member. In some embodiments, at least a portion of the at least one thermal shunt member extends to an exterior of the catheter adjacent the proximal end of the electrode. In one embodiment, at least a portion of the at least one thermal shunt member extends to an exterior of the catheter adjacent the distal end of the electrode. In certain embodiments, at least a portion of the at least one thermal shunt member extends proximally relative to the proximal end of the electrode. In some embodiments, the at least one thermal shunt member comprises a disk or other cylindrically-shaped member.

**[0084]** According to some embodiments, an ablation device comprises an elongate body (e.g., catheter, other medical instrument, etc.) comprising a distal end, an ablation member positioned at the distal end of the elongate body and at least one thermal shunt member placing a heat shunting element in thermal communication with the electrode to selectively remove heat from at least a portion of the electrode and/or tissue being treated by the electrode when the electrode is activated, wherein the heat shunting element of the at least one thermal shunt extends at least partially through an interior of the ablation member to help remove and dissipate heat generated by the ablation member during use. In some embodiments, the at least one thermal shunt member is in thermal communication with at least one fluid conduit or passage extending at least partially through an interior of the elongate body, the at least one fluid conduit or passage being configured to place the ablation member in fluid communication with a fluid source to selectively remove heat from the ablation member and/or tissue of a subject located adjacent the ablation member.

**[0085]** According to some embodiments, the at least one thermal shunt member comprises at least one fluid conduit or passage extending at least partially through an interior of the elongate body. In some embodiments, the at least one thermal shunt member does not comprise a fluid conduit or passage extending at least partially through an interior of the elongate body. In some embodiments, an interior of the distal end of the elongate body comprises an interior member generally along a location of the ablation member. In one embodiment, the interior member comprises at least one thermally conductive material configured to dissipate and/or transfer heat generated by the ablation member.

**[0086]** According to some embodiments, the ablation member comprises a radiofrequency (RF) electrode. In some embodiments, the ablation member comprises one of a microwave emitter, an ultrasound transducer and a cryoablation member.

**[0087]** According to some embodiments, the at least one thermal shunt member comprises at least one extension member extending outwardly from a base member. In some embodiments, the at least one fluid conduit comprises at least one fluid delivery conduit and at least one fluid return conduit, wherein the fluid is at least partially circulated through an interior of the elongate body via the at least one fluid delivery conduit and the at least one fluid return conduit, wherein the at least one fluid conduit is part of a closed-loop or non-open cooling system. In some embodiments, the elongate body comprises a cooling chamber

along a distal end of the elongate body, wherein the cooling chamber is configured to be in fluid communication with the at least one fluid conduit. In some embodiments, the at least one fluid conduit comprises at least one of a metallic material and an alloy. In some embodiments, the elongate body does not comprise a fluid conduit. In one embodiment, an interior of a distal end of the elongate body comprises an interior member generally along a location of the electrode. In some embodiments, the interior member comprises at least one thermally conductive material configured to dissipate and/or transfer heat generated by the electrode.

**[0088]** According to some embodiments, a method of heat removal from an ablation member during a tissue treatment procedure comprises activating an ablation system, the system comprising an elongate body comprising a distal end, an ablation member positioned at the distal end of the elongate body, wherein the elongate body of the ablation system comprises at least one thermal shunt member along its distal end, wherein the at least one thermal shunt member extends at least partially through an interior of the ablation member, and at least partially removing heat generated by the ablation member along the distal end of the elongate body via the at least one thermal shunt member so as to reduce the likelihood of localized hot spots along the distal end of the elongate body.

**[0089]** According to some embodiments, the elongate body (e.g., catheter, medical instrument, etc.) further comprises at least one fluid conduit or passage extending at least partially through an interior of the elongate body, the method further comprising delivering fluid through the at least one fluid conduit or passage, wherein the at least one thermal shunt member places the at least one fluid conduit or passage in thermal communication with a proximal portion of the ablation member to selectively remove heat from the proximal portion of the ablation member when the electrode is activated, wherein the at least one fluid conduit or passage is configured to place the ablation member in fluid communication with a fluid source to selectively remove heat from the ablation member and/or tissue of a subject located adjacent the ablation member.

**[0090]** According to some embodiments, the elongate body is advanced to a target anatomical location of the subject through a bodily lumen of the subject. In some embodiments, the bodily lumen of the subject comprises a blood vessel, an airway or another lumen of the respiratory tract, a lumen of the digestive tract, a urinary lumen or another bodily lumen. In some embodiments, the ablation member comprises a radiofrequency (RF) electrode. In some embodiments, the ablation member comprises one of a microwave emitter, an ultrasound transducer and a cryoablation member. In some embodiments, the at least one thermal shunt member comprises a thermal diffusivity greater than 1.5 cm<sup>2</sup>/sec or 5 cm<sup>2</sup>/sec (e.g., 1.5-2, 2-2.5, 2.5-3, 3-4, 4-5, 5-6, 6-7, 7-8, 8-9, 9-10, 10-11, 11-12, 12-13, 13-14, 14-15, 15-20 cm<sup>2</sup>/sec, values between the foregoing ranges, greater than 20 cm<sup>2</sup>/sec). In some embodiments, the at least one thermal shunt member comprises diamond (e.g., an industrial-grade diamond). In some embodiments, the at least one thermal shunt member comprises a carbon-based material. In some embodiments, the at least one thermal shunt member comprises at least one of Graphene and silica.

**[0091]** According to some embodiments, the radiofrequency (RF) electrode comprises a split-tip RF electrode. In some embodiments, the method further comprises obtaining

at least one high-resolution image of the target anatomical locations of the subject adjacent the ablation member. In some embodiments, the at least one fluid conduit or passage is in direct thermal communication with the at least one thermal shunt member. In some embodiments, the at least one irrigation conduit is not in direct thermal communication with the at least one thermal shunt member. In some embodiments, the at least one fluid conduit or passage directly contacts the at least one thermal shunt member. In one embodiment, the at least one fluid conduit or passage does not contact the at least one thermal shunt member. In certain embodiments, delivering fluid through the at least one fluid conduit or passage comprises delivering fluid to and through the distal end of the catheter in an open irrigation system. In some embodiments, delivering fluid through the at least one fluid conduit or passage comprises circulating fluid through the distal end of the catheter adjacent the ablation member in a closed fluid cooling system.

**[0092]** According to some embodiments, the elongate body (e.g., catheter, medical instrument, etc.) of the ablation system does not comprise any fluid conduits or passages. In some embodiments, the distal end of the elongate body comprises an interior member. In some embodiments, the interior member comprises a thermally conductive material that is in thermal communication with the at least one thermal shunt member to help dissipate and distribute heat generated by the ablation member during use. In some embodiments, at least a portion of the at least one thermal shunt member extends to an exterior of the catheter adjacent the proximal end of the ablation member. In one embodiment, at least a portion of the at least one thermal shunt member extends proximally to the proximal end of the ablation member. In some embodiments, at least a portion of the at least one thermal shunt member extends distally to the proximal end of the ablation member such that at least a portion of the at least one thermal shunt member is located along a length of the ablation member. In some embodiments, the at least one thermal shunt member comprises a disk or other cylindrically-shaped member. In one embodiment, the at least one thermal shunt member comprises at least one extension member extending outwardly from a base member. In some embodiments, the at least one extension member comprises at least one of a fin, a pin or a wing.

**[0093]** According to some embodiments, a system comprising a device in accordance with the present application further comprises means for connectivity to an electrophysiology recorder. In some embodiments, the system is configured to connect to an electrophysiology recorder. In some embodiments, the system further comprises at least one of (i) a generator for selectively energizing the device, and (ii) an electrophysiology recorder.

**[0094]** According to some embodiments, an ablation device comprises an elongate body (e.g., a catheter) having a distal end, an electrode (e.g., a RF electrode, split-tip electrode, etc.) positioned at the distal end of the elongate body, at least one irrigation conduit extending at least partially through an interior of the elongate body, the at least one irrigation conduit configured to place the electrode in fluid communication with a fluid source to selectively remove heat from the electrode and/or tissue of a subject located adjacent the electrode and at least one heat transfer member placing the at least one irrigation conduit in thermal communication with a proximal portion of the electrode to

selectively remove heat from the proximal portion of the electrode when the electrode is activated.

**[0095]** According to some embodiments, an ablation device comprises an elongate body (e.g., a catheter, other medical instrument, etc.) comprising a distal end, an ablation member positioned at the distal end of the elongate body, at least one irrigation conduit extending at least partially through an interior of the elongate body, the at least one irrigation conduit configured to place the ablation member in fluid communication with a fluid source and at least one thermal transfer member placing the at least one irrigation conduit in thermal communication with a proximal portion of the ablation member to selectively remove heat from the proximal portion of the ablation member when the electrode is activated. In some embodiments, the ablation member comprises a radiofrequency (RF) electrode, a microwave emitter, an ultrasound transducer, a cryoablation member and/or any other member.

**[0096]** According to some embodiments, the at least one thermal transfer member comprises a thermal conductance greater than 300 W/m<sup>2</sup> C. (e.g., 300-350, 350-400, 400-450, 450-500 W/m<sup>2</sup> C., ranges between the foregoing, etc.). In other embodiments, the at least one thermal transfer member comprises a thermal conductance greater than 500 W/m<sup>2</sup> C. (e.g., 500-550, 550-600, 600-650, 650-700, 700-800, 800-900, 900-1000 W/m<sup>2</sup> C., ranges between the foregoing, greater than 1000 W/m<sup>2</sup> C., etc.).

**[0097]** According to some embodiments, the at least one thermal transfer member comprises a diamond (e.g., industrial-grade diamond). In some embodiments, the at least one thermal transfer member comprises at least one of a metal and an alloy (e.g., copper, beryllium, brass, etc.).

**[0098]** According to some embodiments, the electrode comprises a radiofrequency (RF) electrode. In one embodiment, the electrode comprises a split-tip electrode. In some embodiments, the split-tip electrode comprises a first electrode portion and at least a second electrode portion, wherein an electrically insulating gap is located between the first electrode portion and the at least a second electrode portion to facilitate high-resolution mapping along a targeted anatomical area.

**[0099]** According to some embodiments, the device further comprises a radiometer. In some embodiments, the radiometer is located in the catheter (e.g., at or near the electrode or other ablation member). In other embodiments, however, the radiometer is located in the handle of the device and/or at another location of the device and/or accompanying system. In embodiments of the device that comprise a radiometer, the catheter comprises one or more antennas (e.g., at or near the electrode) configured to detect microwave signals emitted by tissue. In some embodiments, the device does not comprise a radiometer or does not incorporate radiometry technology (e.g., for measuring temperature of tissue). As discussed herein, other types of temperature-measurement devices (e.g., thermocouples, thermistors, other temperature sensors, etc.) can be incorporated into a device or system.

**[0100]** According to some embodiments, an ablation device consists essentially of a catheter, an ablation member (e.g., a RF electrode, a split-tip electrode, etc.), an irrigation conduit extending through an interior of the catheter to or near the ablation member, at least one electrical conductor (e.g., wire, cable, etc.) to selectively activate the ablation member and at least one heat transfer member that places at

least a portion of the ablation member (e.g., a proximal portion of the ablation member) in thermal communication with the irrigation conduit.

[0101] According to some embodiments, an ablation device consists essentially of a catheter, an ablation member (e.g., a RF electrode, a split-tip electrode, etc.), an irrigation conduit extending through an interior of the catheter to or near the ablation member, at least one electrical conductor (e.g., wire, cable, etc.) to selectively activate the ablation member, an antenna configured to receive microwave signals emitted by tissue of a subject, a radiometer and at least one heat transfer member that places at least a portion of the ablation member (e.g., a proximal portion of the ablation member) in thermal communication with the irrigation conduit.

[0102] According to some embodiments, the at least one irrigation conduit is in direct thermal communication with the at least one thermal transfer member. In some embodiments, the at least one irrigation conduit is not in direct thermal communication with the at least one thermal transfer member. In some embodiments, the irrigation conduit is fluid communication only with exit ports located along the distal end of the elongate body. In some embodiments, the catheter only comprises irrigation exit openings along a distal end of the catheter (e.g., along a distal end or the electrode). In some embodiments, the system does not comprise any irrigation openings along the heat transfer members.

[0103] According to some embodiments, the at least one irrigation conduit directly contacts the at least one thermal transfer member. In some embodiments, the at least one irrigation conduit does not contact the at least one thermal transfer member. In one embodiment, at least a portion of the heat transfer member extends to an exterior of the catheter adjacent the proximal end of the electrode. In some embodiments, at least a portion of the heat transfer member extends proximally to the proximal end of the electrode. In certain embodiments, at least a portion of the heat transfer member extends distally to the proximal end of the electrode such that at least a portion of the heat transfer member is located along a length of the electrode. According to some embodiments, the at least one irrigation conduit comprises a metallic material and/or other thermally conductive materials.

[0104] According to some embodiments, the heat transfer member comprises a disk or other cylindrically-shaped member. In some embodiments, the heat transfer member comprises at least one extension member extending outwardly from a base member.

[0105] According to some embodiments, the device further comprises a radiometer to enable the device and/or accompanying system to detect a temperature to tissue of the subject at a depth. In some embodiments, the radiometer is included, at least in part, in the catheter. In other embodiments, the radiometer is located, at least in part, in the handle of the system and/or in a portion of the device and/or accompanying system external to the catheter.

[0106] According to some embodiments, a method of heat removal from an ablation member during an ablation procedure comprises activating an ablation system, the system comprising an elongate body comprising a distal end, an ablation member positioned at the distal end of the elongate body, at least one irrigation conduit extending at least partially through an interior of the elongate body, and at least one thermal transfer member, wherein the at least one

irrigation conduit configured to place the ablation member in fluid communication with a fluid source to selectively remove heat from the ablation member and/or tissue of a subject located adjacent the ablation member, and delivering fluid through the at least one irrigation conduit, wherein the at least one thermal transfer member places the at least one irrigation conduit in thermal communication with a proximal portion of the ablation member to selectively remove heat from the proximal portion of the ablation member when the electrode is activated.

[0107] According to some embodiments, the elongate body is advanced to a target anatomical location of the subject through a bodily lumen of the subject. In some embodiments, the bodily lumen of the subject comprises a blood vessel, an airway or another lumen of the respiratory tract, a lumen of the digestive tract, a urinary lumen or another bodily lumen.

[0108] According to some embodiments, the ablation member comprises a radiofrequency (RF) electrode, a microwave emitter, an ultrasound transducer, a cryoablation member and/or the like. In some embodiments, the at least one thermal transfer member comprises a thermal conductance greater than  $300 \text{ W/m}^{\circ} \text{ C}$ . In one embodiment, the at least one thermal transfer member comprises a thermal conductance greater than  $500 \text{ W/m}^{\circ} \text{ C}$ .

[0109] According to some embodiments, the at least one thermal transfer member comprises a diamond (e.g., industrial-grade diamond). In some embodiments, the at least one thermal transfer member comprises at least one of a metal and an alloy (e.g., copper, beryllium, brass, etc.).

[0110] According to some embodiments, a system comprises an ablation device according to any of the embodiments disclosed herein. In some embodiments, the system additionally comprises means for connectivity to an electrophysiology recorder. In some embodiments, the system is configured to connect to an electrophysiology recorder. In some embodiments, the system further comprises at least one of (i) a generator for selectively energizing the device, and (ii) an electrophysiology recorder.

[0111] According to one embodiment, a medical instrument (for example, ablation catheter) includes an elongate body having a proximal end and a distal end. The medical instrument also includes an energy delivery member positioned at the distal end of the elongate body that is configured to deliver energy to the targeted tissue. The medical instrument further includes a first plurality of temperature-measurement devices positioned within the energy delivery member and being thermally insulated from the energy delivery member and a second plurality of temperature-measurement devices positioned along the elongate body and spaced apart axially from the first plurality of temperature-measurement devices, the second plurality of temperature-measurement devices also being thermally insulated from the energy delivery member. The energy delivery member may optionally be configured to contact the tissue. The first plurality of temperature-measurement devices may optionally be positioned along a first plane that is substantially perpendicular to a longitudinal axis of the elongate body. The second plurality of temperature-measurement devices may optionally be positioned along a second plane that is substantially perpendicular to a longitudinal axis of the elongate body and spaced apart axially along the longitudinal axis proximal to the first plane. The energy delivery member may optionally comprise one or more electrode

portions, one or more ultrasound transducers, one or more laser elements, or one or more microwave emitters.

**[0112]** According to one embodiment, a medical instrument (for example, an ablation catheter or other device) comprises an elongate body having a proximal end and a distal end. The medical instrument comprises at least one energy delivery member (for example, a tip electrode or multiple electrode portions) positioned at the distal end of the elongate body. In this embodiment, the at least one energy delivery member is configured to deliver energy (for example, radiofrequency energy, acoustic energy, microwave power, laser energy) to the targeted tissue with or without contacting the tissue. In one embodiment, the energy is sufficient to generate a lesion at a depth from a surface of the targeted tissue. The embodiment of the medical instrument comprises a first plurality of temperature-measurement devices carried by, or positioned within separate apertures, recesses or other openings formed in a distal end (for example, a distal-most surface) of the at least one energy delivery member. The first plurality of temperature-measurement devices are thermally insulated from the energy delivery member. The embodiment of the medical instrument comprises a second plurality of temperature-measurement devices positioned adjacent to (for example, within 1 mm of) a proximal end of the at least one energy delivery member (for example, carried by or within the energy delivery member or carried by or within the elongate body proximal of the proximal end of the energy delivery member), the second plurality of temperature-measurement devices being thermally insulated from the at least one energy delivery member. The second plurality of temperature-measurement devices may be positioned just proximal or just distal of the proximal end of the at least one energy delivery member. If the medical instrument comprises two or more energy delivery members, then the second plurality of temperature-measurement devices may be positioned adjacent the proximal edge of the proximal-most energy delivery member and the first plurality of temperature-measurement devices may be positioned within the distal-most energy delivery member. In some embodiments, the second plurality of temperature-measurement devices are positioned along a thermal shunt member (for example, thermal transfer member) proximal of the at least one energy delivery member. In some embodiments, the second plurality of temperature-measurement devices is positioned along a plane that is perpendicular or substantially perpendicular to a longitudinal axis of the distal end of the elongate body and spaced proximal to the first plurality of temperature-measurement devices.

**[0113]** In some embodiments, each of the temperature-measurement devices comprises a thermocouple or a thermistor (for example, Type K or Type T thermocouples). In some embodiments, the first plurality of temperature-measurement devices comprises at least three temperature-measurement devices and the second plurality of temperature-measurement devices comprises at least three temperature-measurement devices. In one embodiment, the first plurality of temperature-measurement devices consists of only three temperature-measurement devices and the second plurality of temperature-measurement devices consists of only three temperature-measurement devices. Each of the first plurality of temperature-measurement devices and each of the second plurality of temperature-measurement devices may be spaced apart (equidistantly or non-equally spaced) from

each of the other temperature-measurement devices of its respective group (for example, circumferentially or radially around an outer surface of the elongate body or otherwise arranged). For example, where three temperature-measurement devices are included in each plurality, group or set, the temperature-measurement devices may be spaced apart by about 120 degrees. In some embodiments, the first plurality of temperature-measurement devices and the second plurality of temperature-measurement devices protrude or otherwise extend beyond an outer surface of the elongate body to facilitate increased depth of insertion (for example, burying) within the targeted tissue. In one embodiment the elongate body is cylindrical or substantially cylindrical. The distal ends of the temperature-measurement devices may comprise a generally rounded casing or shell to reduce the likelihood of penetration or scraping of the targeted tissue.

**[0114]** In accordance with one embodiment, a medical instrument (for example, ablation device) comprises an elongate body having a proximal end and a distal end and a split-tip electrode assembly positioned at the distal end of the elongate body. The split-tip electrode assembly comprises a first electrode member positioned at a distal terminus of the distal end of the elongate body, a second electrode member positioned proximal to the first electrode member and spaced apart from the first electrode member, and an electrically-insulating gap between the first electrode member and the second electrode member. The first electrode member and the second electrode member may be configured to contact tissue of a subject and to deliver radiofrequency energy to the tissue. In some embodiments, the energy may be sufficient to ablate the tissue. The electrically-insulating gap may comprise a gap width separating the first electrode member and the second electrode member. The embodiment of the medical instrument comprises a first plurality of temperature sensors positioned within separate openings, apertures, slits, slots, grooves or bores formed in the first electrode member and spaced apart (for example, circumferentially, radially or otherwise) and a second plurality of temperature sensors positioned at a region proximal to the second electrode member (for example, adjacent to (just proximal or just distal, within less than 1 mm from) a proximal edge of the second electrode member). The second plurality of temperature sensors are thermally insulated from the second electrode member. In some embodiments, the second plurality of temperature sensors is spaced apart circumferentially or radially around an outer circumferential surface of the elongate body. The first plurality of temperature sensors may be thermally insulated from the first electrode member and may extend beyond an outer surface (for example, distal-most surface) of the first electrode member. In one embodiment, at least a portion of each of the second plurality of temperature sensors extends beyond the outer circumferential surface of the elongate body.

**[0115]** In some embodiments, the medical instrument comprises a heat exchange chamber (for example, irrigation conduit) extending at least partially through an interior of the elongate body. The medical instrument may be coupled to a fluid source configured to supply cooling fluid to the heat exchange chamber and a pump configured to control delivery of the cooling fluid to the heat exchange chamber from the fluid source through one or more internal lumens within the heat exchange chamber. In one embodiment, the first electrode member comprises a plurality of irrigation exit ports in fluid communication with the heat exchange

chamber such that the cooling fluid supplied by the fluid source exits from the irrigation exit ports, thereby providing cooling to the split-tip electrode assembly, blood and/or tissue being heated.

**[0116]** For open irrigation arrangements, the medical instrument (for example, ablation device) may comprise a fluid delivery lumen having a diameter or other cross-sectional dimension smaller than the lumen of the heat exchange chamber (for example, irrigation conduit) to facilitate increased velocity to expel the saline or other fluid out of the irrigation exit ports at a regular flow rate. For closed irrigation arrangements, the medical instrument may comprise an inlet lumen (for example, fluid delivery lumen) extending between the heat exchange chamber and the fluid source and an outlet lumen (for example, return lumen) extending between the heat exchange chamber (for example, irrigation conduit) and a return reservoir external to the medical instrument. In one embodiment, a distal end (for example, outlet) of the inlet lumen is spaced distally from the distal end (for example, inlet) of the outlet lumen so as to induce turbulence or other circulation within the heat exchange chamber. In various embodiments, an irrigation flow rate is 10 mL/min or less (for example, 9 mL/min or less, 8 mL/min or less, 7 mL/min or less, 6 mL/min or less, 5 mL/min or less). In some embodiments, the medical instruments are not irrigated.

**[0117]** According to one embodiment, a medical instrument (for example, ablation device) comprises an elongate body (for example, a catheter, wire, probe, etc.) comprising a proximal end and a distal end and a longitudinal axis extending from the proximal end to the distal end. The medical instrument comprises a split-tip electrode assembly. In the embodiment, the split-tip electrode assembly comprises a first electrode member positioned at a distal terminus of the distal end of the elongate body and a second electrode member positioned proximal to the first electrode member and spaced apart from the first electrode member. The first electrode member and the second electrode member are configured to contact tissue of a subject and to deliver radiofrequency energy to the tissue. The energy delivered may be sufficient to at least partially ablate or otherwise heat the tissue. The split-tip electrode assembly also comprises an electrically-insulating gap comprising a gap width separating the first electrode member and the second electrode member. The embodiment of the ablation device further comprises at least one thermal transfer member in thermal communication with the first and second electrode members to selectively remove or dissipate heat from the first and second electrode members, a first plurality of temperature-measurement devices positioned within the first electrode member and spaced apart (for example, circumferentially, radially) and a second plurality of temperature-measurement devices positioned within a portion of the at least one thermal heat shunt member (for example, heat transfer member) proximal to the second electrode member. The first plurality of temperature-measurement devices is thermally insulated from the first electrode member and may extend beyond an outer surface of the first electrode member in a direction that is at least substantially parallel to the longitudinal axis of the elongate body. The second plurality of thermocouples is thermally insulated from the second electrode member and may extend beyond an outer surface

of the at least one thermal heat shunt member in a direction that is at least substantially perpendicular to the longitudinal axis of the elongate body.

**[0118]** In some embodiments, the medical instrument comprises a heat exchange chamber (for example, irrigation conduit) extending at least partially through an interior of the elongate body. The medical instrument may be fluidly coupled to a fluid source configured to supply cooling fluid to the heat exchange chamber and a pump configured to control delivery of the cooling fluid. In one embodiment, the first electrode member comprises a plurality of irrigation exit ports in fluid communication with the heat exchange chamber such that the cooling fluid supplied by the fluid source is expelled from the irrigation exit ports, thereby providing cooling to the split-tip electrode assembly. In some embodiments, at least an inner surface or layer of the heat exchange chamber comprises a biocompatible material, such as stainless steel.

**[0119]** In some embodiments, the at least one thermal shunt member (for example, heat shunt network or heat transfer member(s)) comprises a thermal conductance greater than 300 W/m<sup>2</sup> C. (for example, 300-350, 350-400, 400-450, 450-500 W/m<sup>2</sup> C., ranges between the foregoing, etc.). In other embodiments, the at least one thermal transfer member comprises a thermal conductance greater than 500 W/m<sup>2</sup> C. (for example, 500-550, 550-600, 600-650, 650-700, 700-800, 800-900, 900-1000 W/m<sup>2</sup> C., ranges between the foregoing, greater than 1000 W/m<sup>2</sup> C., etc.). According to some embodiments, the at least one thermal transfer member comprises a diamond (for example, industrial-grade diamond).

**[0120]** The electrode member(s) may comprise platinum in any of the embodiments. The temperature-measurement devices may comprise one of more of the following types of thermocouples: nickel alloy, platinum/rhodium alloy, tungsten/rhenium alloy, gold/iron alloy, noble metal alloy, platinum/molybdenum alloy, iridium/rhodium alloy, pure noble metal, Type K, Type T, Type E, Type J, Type M, Type N, Type B, Type R, Type S, Type C, Type D, Type G, and/or Type P.

**[0121]** According to some embodiments, the medical instrument comprises at least one separator positioned within the at least one electrically-insulating gap. In one embodiment, the at least one separator comprises a portion of the at least one thermal transfer member. For example, the at least one separator may comprise industrial grade diamond.

**[0122]** According to some embodiments, the medical instrument comprises at least one conductor configured to conduct current from an energy source to the split-tip electrode assembly or other ablation members. In some embodiments, the first plurality of thermocouples or other temperature-measurement devices and the second plurality of thermocouples or other temperature-measurement devices extend up to 1 mm beyond the outer surface of the first electrode member and the at least one thermal transfer member, respectively.

**[0123]** According to some embodiments, an outer diameter of a portion of the at least one thermal heat transfer member comprising the second plurality of temperature-measurement devices is greater than the outer diameter of the elongate body so as to facilitate greater insertion depth within the tissue, thereby increasing isolation of the ther-

mocouples or other temperature-measurement devices from the thermal effects of the electrode member(s).

**[0124]** In accordance with several embodiments, a treatment system comprises a medical instrument (for example, an ablation catheter), a processor, and an energy source. The medical instrument comprises an elongate body having a proximal end and a distal end, an energy delivery member (for example, electrode) positioned at the distal end of the elongate body, a first plurality of temperature-measurement devices carried by or positioned along or within the energy delivery member, and a second plurality of temperature-measurement devices positioned proximal of the electrode along the elongate body. The energy delivery member may be configured to contact tissue of a subject and to deliver energy generated by the energy source to the tissue. In some embodiments, the energy is sufficient to at least partially ablate the tissue. In some embodiments, the first plurality of temperature-measurement devices are thermally insulated from the energy delivery member and the second plurality of temperature-measurement devices are thermally insulated from the energy delivery member. In one embodiment, the second plurality of temperature-measurement devices is spaced apart around an outer surface of the elongate body. The energy source of the embodiment of the system may be configured to provide the energy to the energy delivery member through one or more conductors (for example, wires, cables, etc.) extending from the energy source to the energy delivery member.

**[0125]** The processor of the embodiment of the system may be programmed or otherwise configured (for example, by execution of instructions stored on a non-transitory computer-readable storage medium) to receive signals from each of the temperature-measurement devices indicative of temperature and determine an orientation of the distal end of the elongate body of the ablation catheter with respect to the tissue based on the received signals. In some embodiments, the processor may be configured to adjust one or more treatment parameters based on the determined orientation. The one or more treatment parameters may include, among other things, duration of treatment, power of energy, target or setpoint temperature, and maximum temperature.

**[0126]** In some embodiments, the processor is configured to cause an identification of the determined orientation to be output to a display. The output may comprise textual information (such as a word, phrase, letter or number). In some embodiments, the display comprises a graphical user interface and the output comprises one or more graphical images indicative of the determined orientation.

**[0127]** In some embodiments, the determination of the orientation of the distal end of the elongate body of the medical instrument with respect to the tissue is based on a comparison of tissue measurements determined from received signals with respect to each other. The orientation may be selected from one of three orientation options: perpendicular, parallel and angled or oblique. In one embodiment, the processor is configured to generate an output to terminate delivery of energy if the determined orientation changes during energy delivery (for example, an alarm to cause a user to manually terminate energy delivery or a signal to automatically cause termination of energy delivery).

**[0128]** According to some embodiments, a treatment system comprises a medical instrument (for example, an ablation catheter) and a processor. The medical instrument may

comprise an elongate body having a proximal end and a distal end, an energy delivery member positioned at the distal end of the elongate body, the energy delivery member being configured to contact tissue of a subject and to deliver energy (for example, ablative energy) to the tissue, a first plurality of temperature-measurement devices positioned within the energy delivery member, and a second plurality of temperature-measurement devices positioned proximal to the energy delivery member along the elongate body. The first plurality of temperature-measurement devices may be thermally insulated from the energy delivery member and may be spaced apart from each other and the second plurality of temperature-measurement devices may be thermally insulated from the energy delivery member and may be spaced apart around an outer surface of the elongate body.

**[0129]** A processor of the embodiment of the treatment system may be programmed or otherwise configured (for example, by execution of instructions stored on a non-transitory computer-readable storage medium) to receive signals from each of the temperature-measurement devices, and calculate a peak temperature of the tissue at a depth based on the received signals. The peak temperature may comprise an extreme temperature (for example, a peak or a valley/trough temperature, a hot or a cold temperature, a positive peak or a negative peak).

**[0130]** According to some embodiments, the processor is configured to calculate the peak temperature of the tissue at a depth by comparing individual temperature measurements determined from the received signals to each other. In some embodiments, the processor is configured to adjust one or more treatment parameters based on the calculated peak temperature, including duration of treatment, power of energy, target temperature, and maximum temperature.

**[0131]** According to some embodiments, the processor is configured to generate an output to automatically terminate delivery of energy if the calculated peak temperature exceeds a threshold temperature or to generate an alert to cause a user to manually terminate energy delivery. In some embodiments, the processor is configured to cause an identification of the calculated peak temperature to be output to a display (for example, using a color, textual information, and/or numerical information).

**[0132]** In accordance with several embodiments, a treatment system comprises a medical instrument (for example, ablation catheter) comprising an elongate body comprising a proximal end and a distal end, an energy delivery member positioned at the distal end of the elongate body. In one embodiment, the energy delivery member (for example, electrode) is configured to contact tissue of a subject and to deliver energy (for example, ablative energy) to the tissue. The medical instrument comprises a first plurality of temperature-measurement devices positioned within separate openings or apertures formed in the energy delivery member, and a second plurality of temperature-measurement devices positioned proximal to the energy delivery member along the elongate body. The first plurality of temperature-measurement devices may be thermally insulated from the electrode and spaced apart from each other and the second plurality of temperature-measurement devices may be thermally insulated from the electrode. In one embodiment, the second plurality of temperature-measurement devices is spaced apart around an outer surface of the elongate body. The treatment system may also comprise a processor that is programmed or otherwise configured (for example, by

execution of instructions stored on a non-transitory computer-readable storage medium) to receive signals from each of the temperature-measurement devices and determine an estimated location of a peak temperature zone at a depth within the tissue based, at least in part, on the received signals. In some embodiments, the processor determines individual temperature measurements based on the received signals and compares them to determine the estimated location of the peak temperature. The processor may be configured to adjust one or more treatment parameters based on the estimated location, including duration, power, target temperature, and maximum temperature. The processor may also be configured to cause an identification of the estimated location to be output to a display. The output may comprise alphanumeric information and/or one or more graphical images indicative of the estimated location of the peak temperature zone.

**[0133]** In accordance with several embodiments, a method of determining a peak temperature of tissue being ablated at a depth from a surface of the tissue may comprise receiving signals indicative of temperature from a first plurality of temperature sensors positioned at a distal end of an ablation catheter. In one embodiment, each of the first plurality of temperature sensors is spaced apart around the distal end of the ablation catheter. The method also comprises receiving signals indicative of temperature from a second plurality of temperature sensors positioned at a distance proximal to the first plurality of temperature sensors. The method further comprises determining temperature measurements from the signals received from the first plurality of temperature sensors and the second plurality of temperature sensors and comparing the determined temperature measurements to each other. In some embodiments, the method comprises applying one or more correction factors to one or more of the determined temperature measurements based, at least in part, on the comparison to determine the peak temperature. In one embodiment, the method comprises outputting the determined peak temperature on a display textually, visually and/or graphically. In one embodiment, the method comprises adjusting one or more treatment (for example, ablation) parameters and/or terminating ablation based on the determined hotspot temperature. The second plurality of temperature sensors may be spaced apart around a circumference of the ablation catheter or other medical instrument.

**[0134]** According to some embodiments, a method of determining a location of a peak temperature zone within tissue being ablated comprises receiving signals indicative of temperature from a first plurality of temperature sensors positioned at a distal end of an ablation catheter. In one embodiment, each of the first plurality of temperature sensors are spaced apart around the distal end of the ablation catheter. The method comprises receiving signals indicative of temperature from a second plurality of temperature sensors positioned at a distance proximal to the first plurality of temperature sensors. The method further comprises determining temperature measurements from the signals received from the first plurality of temperature sensors and the second plurality of temperature sensors and, comparing the determined temperature measurements to each other. The method may comprise determining a location of a peak temperature zone of a thermal lesion based, at least in part, on the comparison. In one embodiment, the method comprises outputting the determined peak location on a display, textually, visually and/or graphically. In one embodiment, each

of the second plurality of temperature sensors is spaced apart around a circumference of the ablation catheter.

**[0135]** According to some embodiments, a method of determining an orientation of a distal tip of an ablation catheter with respect to tissue in contact with the distal tip comprises receiving signals indicative of temperature from a first plurality of temperature sensors positioned at a distal end of an ablation catheter and receiving signals indicative of temperature from a second plurality of temperature sensors positioned at a distance proximal to the first plurality of temperature sensors. The method further comprises determining temperature measurements from the signals received from the first plurality of temperature sensors and the second plurality of temperature sensors and comparing each of the determined temperature measurements with each other. The method further comprises determining an orientation of a distal tip of an ablation catheter with respect to tissue in contact with the distal tip based, at least in part, on the comparison. In one embodiment, the method comprises outputting the determined orientation on a display. The output may comprise textual information or one or more graphical images. The embodiments of the methods may also comprise terminating energy delivery or generating an output (for example, an alert) to signal to a user that energy delivery should be terminated. In some embodiments, each of the first plurality of temperature sensors is spaced apart around a distal end of the ablation catheter and each of the second plurality of temperature sensors is spaced apart around a circumference of the ablation catheter.

**[0136]** In accordance with several embodiments, a system comprises at least one signal source configured to deliver at least a first frequency and a second frequency to a pair of electrodes or electrode portions of a combination electrode or electrode assembly. The system also comprises a processing device configured to: obtain impedance measurements while the first frequency and the second frequency are being applied to the pair of electrodes by the signal source, process the electrical (for example, voltage, current, impedance) measurements obtained at the first frequency and the second frequency, and determine whether the pair of electrodes is in contact with tissue based on said processing of the electrical (for example, impedance) measurements. The pair of electrodes may be positioned along a medical instrument (for example, at a distal end portion of an ablation catheter). The pair of electrodes may comprise radiofrequency electrodes and the at least one signal source may comprise one, two or more sources of radiofrequency energy.

**[0137]** The signal source may comprise a first signal source configured to generate, deliver or apply signals to the pair of electrodes having a frequency configured for tissue ablation and a second signal source configured to generate, deliver or apply signals to the pair of electrodes having frequencies adapted for contact sensing and/or tissue type determination (for example, whether the tissue is ablated or still viable). The first and second signal sources may be integrated within an energy delivery module (for example, RF generator) or within an elongate body or handle of a medical instrument (for example, ablation catheter). In some embodiments, the second signal source is within a contact sensing subsystem, which may be a distinct and separate component from the energy delivery module and medical instrument or integrated within the energy delivery module or medical instrument. In one embodiment, only one signal source capable of applying signals having frequencies

adapted for ablation or other treatment and signals having frequencies adapted for contact sensing or tissue type determination functions is used. The frequencies adapted for contact sensing or tissue type determination may be within the treatment frequency range or outside the treatment frequency range. By way of example, in one non-limiting embodiment, the system comprises an energy source configured to generate, deliver or apply signals to at least a pair of electrode members (and also to a ground pad or reference electrode) to deliver energy having a frequency configured for tissue ablation or other treatment and a signal source configured to generate, deliver or apply signals to the pair of electrode members (and not to a ground pad or reference electrode) having frequencies adapted for contact sensing and/or tissue type determination (for example, whether the tissue is ablated or still viable). The energy source and the signal source may both be integrated within an energy delivery module (for example, RF generator) or one of the sources (for example, the signal source) may be incorporated within an elongate body or handle of a medical instrument (for example, ablation catheter). In some embodiments, the signal source is within a contact sensing subsystem, which may be a distinct and separate component from the energy delivery module and medical instrument or integrated within the energy delivery module or medical instrument. In some embodiments, a single source configured for applying signals having frequencies adapted for ablation or other treatment and configured for applying signals having frequencies adapted for contact sensing or tissue type determination functions is used. Signals having the treatment frequencies may also be delivered to a ground pad or reference electrode.

**[0138]** In some embodiments, the system consists essentially of or comprises a medical instrument (for example, an energy delivery device), one or more energy sources, one or more signal sources and one or more processing devices. The medical instrument (for example, energy delivery catheter) may comprise an elongate body having a proximal end and a distal end and a pair of electrodes or electrode portions (for example, a combination, or split-tip, electrode assembly) positioned at the distal end of the elongate body. In one embodiment, the pair of electrodes comprises a first electrode positioned on the elongate body and a second electrode positioned adjacent (for example, proximal of) the first electrode. The first electrode and the second electrode may be configured to contact tissue of a subject and provide energy to the tissue to heat (for example, ablate or otherwise treat) the tissue at a depth from the surface of the tissue. In one embodiment, the pair of electrodes comprises an electrically insulating gap positioned between the first electrode and the second electrode, the electrically insulating gap comprising a gap width separating the first and second electrodes. A separator (for example, a capacitor or insulation material) may be positioned within the electrically insulating gap.

**[0139]** The one or more signal sources may be configured to deliver signals over a range of frequencies (for example, frequencies within a radiofrequency range). In some embodiments, the processing device is configured to execute specific program instructions stored on a non-transitory computer-readable storage medium to: obtain impedance or other electrical measurements while different frequencies of energy within the range of frequencies are being applied to the pair of electrodes by a signal source, process the impedance or other electrical measurements obtained at the first

frequency and the second frequency, and determine whether at least one of (for example, the distal-most electrode) the pair of electrodes is in contact with tissue based on said processing of the impedance or other electrical measurements.

**[0140]** In some embodiments, the medical instrument consists essentially of or comprises a radiofrequency ablation catheter and the first and second electrodes or electrode portions comprise radiofrequency electrodes. The signal source(s) may comprise a radiofrequency (RF) generator. In one embodiment, the range of frequencies that is delivered by the signal source(s) (for example, of a contact sensing subsystem) comprises at least a range between 1 kHz and 5 MHz (for example, between 5 kHz and 1000 kHz, between 10 kHz and 500 kHz, between 5 kHz and 800 kHz, between 20 kHz and 800 kHz, between 50 kHz and 5 MHz, between 100 kHz and 1000 kHz, and overlapping ranges thereof). The signal source(s) may also be configured to deliver frequencies below and above this range. The frequencies may be at least greater than five times or at least greater than ten times the electrogram mapping frequencies so as not to interfere with high-resolution mapping images or functions obtained by the first and second electrodes or electrode portions. In one embodiment, the different frequencies at which impedance measurements are obtained consists only of two discrete frequencies. In another embodiment, the different frequencies comprise two or more discrete frequencies. In some embodiments, the processing device is configured to obtain impedance measurements while a full sweep of frequencies from a minimum frequency to a maximum frequency of the range of frequencies is applied to the pair of electrodes or electrode portions. As one example, the range of frequencies is between 5 kHz and 1000 kHz. The second frequency may be different from (for example, higher or lower than) the first frequency.

**[0141]** The system may comprise an ablative energy source (for example, signal source such as an RF generator) configured to deliver signals to the pair of electrodes (and possibly also to a ground pad or reference electrode) to generate energy sufficient to ablate or otherwise treat tissue (such as cardiac tissue). In one embodiment, the processing device is configured to adjust one or more energy delivery parameters of the ablative energy based on a determination of whether at least one of the pair of electrodes is in contact with tissue and/or is configured to terminate energy delivery based on a determination of whether at least one of the pair of electrodes is in contact with tissue or that contact has been lost. In some embodiments, the ablative energy source and the at least one signal source comprise a single source. In other embodiments, the signal source comprises a first source and the ablative energy source comprises a second source that is separate and distinct from the first source. In some embodiments, the processing is performed in the time domain. In some embodiments, the processing is performed in the frequency domain. Portions of the processing may be performed in both the time domain and the frequency domain.

**[0142]** In some embodiments, the processing device is configured to execute specific program instructions stored on a non-transitory computer-readable storage medium to generate an output indicative of contact. The processing device may be configured to cause the generated output to be displayed on a display (for example an LCD or LED monitor) in communication with the processing device. In

various embodiments, the output comprises textual information, quantitative information (for example, numeric information, binary assessment of whether contact exists or not) and/or a qualitative information (for example, color or other information indicative of a level of contact).

**[0143]** In accordance with several embodiments, a system comprises a signal source configured to deliver signals having a range of frequencies and a processing device configured to execute specific program instructions stored on a non-transitory computer-readable storage medium to: obtain impedance or other electrical measurements while different frequencies of energy are being applied to a pair of electrodes (for example, combination electrode, or split-tip, electrode assembly) by the signal source, compare the impedance measurements obtained at the different frequencies of energy; and determine whether or not tissue in contact with at least one of the pair of electrodes has been ablated. In some embodiments, the range of frequencies over which contact determination is made is between 5 kHz and 1000 kHz. The different frequencies consist of two discrete frequencies in one embodiment or may comprise two or more discrete frequencies in other embodiments. The processing device may be configured to obtain impedance measurements while a full sweep of frequencies from a minimum frequency to a maximum frequency of the range of frequencies (for example, 5 kHz to 1000 kHz) is applied to the pair of electrodes. In some embodiments, one component of an impedance measurement (for example, impedance magnitude) is obtained at a first frequency and a second component of a different impedance measurement (for example, phase angle) is obtained at a second frequency. A comparison (for example, derivative of impedance versus frequency, delta or slope of impedance vs. frequency) of impedance magnitude measurements at two or more different frequencies may also be obtained. A weighted combination of various impedance measurements at two or more different frequencies may be calculated by the processing device and used by the processing device to determine an overall contact level or state. The impedance measurements may be obtained directly or may be calculated based on electrical parameter measurements, such as voltage and/or current measurements.

**[0144]** In some embodiments, the processing device is configured to execute specific program instructions stored on a non-transitory computer-readable storage medium to generate an output indicative of tissue type based on the determination of whether or not tissue in contact with at least one of the pair of electrodes has been ablated. The processing device may be configured to cause the generated output to be displayed on a display in communication with the processing device. The output may comprise one or more of textual information, a color or other qualitative information, and numerical information. In various embodiments, the processing device is configured to adjust one or more energy delivery parameters based on the determination of whether the tissue in contact with the pair of electrodes has been ablated and/or is configured to terminate energy delivery based on the determination of whether tissue in contact with the pair of electrodes has been ablated.

**[0145]** In accordance with several embodiments, a system for determining whether a medical instrument is in contact with tissue based, at least in part, on impedance measurements comprises a signal source configured to deliver signals having different frequencies to a pair of electrodes of a

medical instrument and a processing device configured to process a resulting waveform that formulates across the pair of electrodes to obtain impedance measurements at a first frequency and a second frequency and determine a ratio between the magnitude of the impedance at the second frequency and the first frequency. If the determined ratio is below a predetermined threshold indicative of contact, the processing device is configured, upon execution of stored instructions on a computer-readable medium, to generate a first output indicative of contact. If the determined ratio is above the predetermined threshold, the processing device is configured to, upon execution of stored instructions on a computer-readable medium, generate a second output indicative of no contact. In one embodiment, the signal source comprises a radiofrequency energy source. The first and second frequencies may be between 5 kHz and 1000 kHz. In some embodiments, the signal source is configured to generate signals having a frequency adapted for tissue ablation. In other embodiments, the system comprises a second signal source (or an ablative energy source) configured to generate signals having a frequency adapted for tissue ablation. The frequency adapted for tissue ablation may be between 400 kHz and 600 kHz (for example, 400 kHz, 450 kHz, 460 kHz, 480 kHz, 500 kHz, 550 kHz, 600 kHz, 400 kHz-500 kHz, 450 kHz-550 kHz, 500 kHz-600 kHz, or overlapping ranges thereof). In various embodiments, the predetermined threshold is a value between 0.5 and 0.9. Processing the waveforms may comprise obtaining voltage and/or current measurements and calculating impedance measurements based on the voltage and/or current measurements or directly obtaining impedance measurements.

**[0146]** A method of determining whether a medical instrument is in contact with a target region (for example, tissue) based, at least in part, on electrical measurements (for example, impedance measurements), may comprise applying signals having a first frequency and a second frequency to a pair of electrodes or electrode portions of the medical instrument, processing a resulting waveform to obtain impedance measurements at the first frequency and the second frequency, and determining a ratio between the magnitude of the impedance at the second frequency and the first frequency. If the determined ratio is below a predetermined threshold indicative of contact, the method comprises generating a first output indicative of contact. If the determined ratio is above the predetermined threshold, the method comprises generating a second output indicative of no contact.

**[0147]** In accordance with several embodiments, a system for determining a contact state of a distal end portion of a medical instrument with a target region (for example, tissue) based, at least in part, on electrical measurements comprises a signal source configured to generate at least one signal having a first frequency and a second frequency to be applied to a pair of electrode members of a combination electrode assembly. The signal source may be a component of a contact sensing or detection subsystem or an energy delivery module, such as a radiofrequency generator. The system also comprises a processor or other computing device configured to, upon execution of specific program instructions stored in memory or a non-transitory computer-readable storage medium, cause the signal source to generate and apply the at least one signal to the pair of electrode

members. The signal may be a single multi-tone waveform or signal or multiple waveforms or signals having a single frequency.

**[0148]** The processor may be configured to process a resulting waveform that formulates across the pair of electrode members to obtain a first electrical measurement at the first frequency and to process the resulting waveform that formulates across the pair of electrode members to obtain a second electrical measurement at the second frequency of the plurality of frequencies. The processor is further configured to: determine an impedance magnitude based on the first electrical measurement (for example, voltage and/or current measurement), determine an impedance magnitude and a phase based on the second electrical measurement, and calculate a contact indication value indicative of a state of contact between the distal end portion of the medical instrument and the target region based on a criterion combining the impedance magnitude based on the first electrical measurement, a ratio of the impedance magnitudes based on the first electrical measurement and the second electrical measurement, and the phase based on the second electrical measurement. The first and second electrical measurements may comprise voltage and/or current measurements or direct impedance measurements between the pair of electrode members. In some embodiments, the first and second electrical measurements do not comprise direct measurements of electrical parameters between an electrode and tissue but are measurements between two electrode members. Impedance measurements may be calculated based on the voltage and/or current measurements.

**[0149]** In some embodiments, the criterion comprises a weighted combination of the impedance magnitude based on the first electrical measurement, a ratio of the impedance magnitudes based on the first and second electrical measurements, and the phase based on the second electrical measurement. In some embodiments, the criterion comprises an if-then case conditional criterion, such as described in connection with FIGS. 11 and 11A. In various embodiments, only one impedance measurement or calculation (for example, only impedance magnitude, only slope between impedance magnitude values, or only phase) or only two types of impedance measurements or calculations are used to determine the contact state.

**[0150]** In accordance with several embodiments, a system for determining whether a medical instrument is in contact with a target region (for example, tissue) based, at least in part, on impedance measurements consists essentially of or comprises a signal source configured to generate one or more signals having a first frequency and a second frequency to a pair of electrodes (for example, positioned at a distal end of a medical instrument, catheter or probe) and a processing device configured to execute specific program instructions stored on a non-transitory computer-readable storage medium to process a resulting waveform that formulates across the pair of electrodes to obtain impedance measurements at the first frequency and the second frequency. If the impedance magnitude at the first and/or second frequency is above a predetermined threshold indicative of contact, the processing device is configured to, upon execution of stored instructions on the computer-readable storage medium, generate a first output indicative of contact. If the impedance magnitude at the first and/or second frequency is below a predetermined threshold indicative of no contact, the processing device is configured to, upon

execution of stored instructions on the computer-readable storage medium, generate a second output indicative of no contact. Processing the waveforms may comprise obtaining voltage and/or current measurements and calculating impedance measurements based on the voltage and/or current measurements or directly obtaining impedance measurements.

**[0151]** A method of determining whether a medical instrument is in contact with a target region (for example, tissue) based, at least in part, on impedance measurements comprises delivering at least one signal having a first frequency and a second frequency (for example, a multi-tonal waveform) to a pair of electrodes or electrode portions and processing a resulting waveform that formulates across the pair of electrodes to obtain impedance measurements at the first frequency and the second frequency. If the impedance magnitude at the first frequency and/or second frequency is above a predetermined threshold indicative of contact, the method comprises generating a first output indicative of contact. If the impedance magnitude at the first frequency and/or second frequency is below a predetermined threshold indicative of no contact, the method comprises generating a second output indicative of no contact.

**[0152]** A method of determining whether a medical instrument is in contact with a target region (for example, tissue) based, at least in part, on impedance measurements may comprise applying a signal comprising a multi-tone waveform having a first frequency and a second frequency to a pair of electrodes, processing the resulting waveform to obtain impedance measurements at the first frequency and the second frequency, comparing values of the impedance measurements at the first frequency and the second frequency to a known impedance of blood or a blood and saline mixture (or other known tissue impedance), comparing values of the impedance measurements at the first and second frequency to each other; and generating an output indicative of whether or not the medical instrument is in contact with tissue based on said comparisons. A system for determining whether a medical instrument is in contact with tissue based, at least in part, on impedance measurements may comprise a signal source configured to generate a multi-tone waveform or signal having a first frequency and a second frequency to a pair of electrodes (for example, at a distal end of a split-tip electrode catheter); and a processing device. The processing device may be configured to, upon execution of stored instructions on a computer-readable storage medium, process the resulting waveform to obtain impedance measurements at the first frequency and the second frequency, compare values of the impedance measurements at the first frequency and the second frequency to a known impedance of blood or a blood and saline mixture, compare values of the impedance measurements at the first and second frequency to each other and/or generate an output indicative of whether or not the medical instrument is in contact with tissue based on said comparisons.

**[0153]** In accordance with several embodiments, a method of determining whether a medical instrument comprising a pair of electrodes or electrode portions is in contact with a target region (for example, tissue) based, at least in part, on impedance measurements comprises applying at least one signal having a plurality of frequencies (for example, a multi-tonal waveform) to a pair of electrodes of a medical instrument, and processing a resulting waveform that formulates across the pair of electrodes to obtain impedance

measurements at a first frequency and a second frequency of the plurality of frequencies. If a variation of the impedance measurements across the range of frequencies has a model whose parameter values are indicative of contact, the method comprises generating a first output indicative of contact. If the variation of the impedance measurements across the range of frequencies has a model whose parameter values are indicative of no contact, the method comprises generating a second output indicative of no contact. The model may comprise a fitting function or a circuit model such as shown in FIG. 5B. A system for determining whether a medical instrument is in contact with tissue based, at least in part, on impedance measurements comprises a signal source configured to generate at least one signal having a first frequency and a second frequency to a pair of electrodes and a processing device. The processing device may be configured to, upon execution of stored instructions on a computer-readable storage medium, apply at least one signal having a plurality of frequencies to a pair of electrodes of a medical instrument and process a resulting waveform that formulates across the pair of electrodes to obtain impedance measurements at a first frequency and a second frequency of the plurality of frequencies. If a variation of the impedance measurements across the range of frequencies follows a model whose parameter values are indicative of contact the processor is configured to generate a first output indicative of contact. If the variation of the impedance measurements across the range of frequencies follows a model whose parameter values are indicative of no contact, the processor is configured to generate a second output indicative of no contact. Processing the waveforms to obtain impedance measurements may comprise obtaining voltage and/or current measurements and calculating impedance measurements based on the voltage and/or current measurements or directly obtaining impedance measurements.

**[0154]** In accordance with several embodiments, a method of determining whether tissue has been ablated by an ablation catheter comprising a pair of electrodes is provided. The method comprises applying one or more signals having a first frequency and a second frequency (for example, a multi-tonal waveform) to a pair of electrodes along the ablation catheter and processing a resulting waveform that formulates across the pair of electrodes to obtain impedance measurements at the first frequency and the second frequency. The method may comprise assessing absolute change in the impedance as well as the slope or ratio between impedance. If the first impedance measurement at the first and/or second frequency is greater than a known impedance level of blood and if a ratio of the second impedance measurement to the first impedance measurement is above a predetermined threshold, the method comprises generating a first output indicative of ablated tissue. If the first impedance measurement at the first and/or second frequency is greater than a known impedance level of blood and if a ratio of the second impedance measurement to the first impedance measurement is below a predetermined threshold, the method comprises generating a second output indicative of viable tissue. Processing the waveforms to obtain impedance measurements may comprise obtaining voltage and/or current measurements and calculating impedance measurements based on the voltage and/or current measurements or directly obtaining impedance measurements.

**[0155]** In some embodiments, a phase of the impedance measurements at the first frequency and/or second frequency is compared to a known phase response for blood or a blood and saline mixture and utilized in conjunction with the magnitude values of the impedance measurements to generate an output indicative of whether or not the medical instrument is in contact with tissue. A system for determining whether tissue has been ablated by an ablation catheter comprising a pair of electrodes or electrode portions may comprise a signal source configured to generate at least one signal having a first frequency and a second frequency to a pair of electrodes along the ablation catheter and a processing device. The processing device may be configured to, upon execution of stored instructions on a computer-readable storage medium, process a resulting waveform that formulates across the pair of electrodes to obtain impedance measurements at the first frequency and the second frequency. If the first impedance measurement at the first and/or second frequency is greater than a known impedance level of blood and if a ratio of the second impedance measurement to the first impedance measurement is above a predetermined threshold, the processing device is configured to generate a first output indicative of ablated tissue. If a ratio of the second impedance measurement to the first impedance measurement is below a predetermined threshold, the processor is configured to generate a second output indicative of viable (for example, unablated) tissue. Processing the waveforms to obtain impedance measurements may comprise obtaining voltage and/or current measurements and calculating impedance measurements based on the voltage and/or current measurements or directly obtaining impedance measurements.

**[0156]** Processing the resulting waveform may comprise applying a transform (for example, a Fourier transform) to the waveform to obtain the impedance measurements. In some embodiments, the first frequency and the second frequency are within a range between 5 kHz and 1000 kHz. In one embodiment, the second frequency is higher than the first frequency. The impedance measurements may be obtained simultaneously or sequentially. The second frequency may be at least 20 kHz higher than the first frequency. In one embodiment, the first frequency is between 10 kHz and 100 kHz (for example, between 10 kHz and 30 kHz, between 15 kHz and 40 kHz, between 20 kHz and 50 kHz, between 30 kHz and 60 kHz, between 40 kHz and 80 kHz, between 50 kHz and 90 kHz, between 60 kHz and 100 kHz, overlapping ranges thereof, 20 kHz or any values from 10 kHz and 100 kHz) and the second frequency is between 400 kHz and 1000 kHz (for example, between 400 kHz and 600 kHz, between 450 kHz and 750 kHz, between 500 kHz and 800 kHz, between 600 kHz and 850 kHz, between 700 kHz and 900 kHz, between 800 kHz and 1000 kHz, overlapping ranges thereof, 800 kHz, or any values from 400 kHz to 1000 kHz). The predetermined threshold may have a value between 0.5 and 0.9. In some embodiments, generating a first output and generating a second output further comprises causing the first output or the second output to be displayed on a display (for example via one or more display drivers). The output may comprise textual information, quantitative measurements and/or qualitative assessments indicative of contact state. In some embodiments, the output includes an amount of contact force corresponding to the level of contact (for example, grams of force).

**[0157]** A method of determining whether a medical instrument having a pair of electrodes or electrode portions is in contact with a target region (for example, tissue) based, at least in part, on impedance measurements may comprise obtaining a first impedance measurement at a first frequency within a range of frequencies, obtaining a second impedance measurement at a second frequency within the range of frequencies and obtaining a third impedance measurement at a third frequency within the range of frequencies. If a variation of the impedance measurements across the range of frequencies is above a predetermined threshold indicative of contact, the method comprises generating a first output indicative of contact. If the variation of the impedance measurements across the range of frequencies is below the predetermined threshold, the method comprises generating a second output indicative of no contact. The impedance measurements may be calculated based on voltage and/or current measurements or may be directly-measured impedance measurements.

**[0158]** The range of frequencies may be between 5 kHz and 5 MHz (for example, between 5 kHz and 1000 kHz, between 1 MHz and 3 MHz, between 2.5 MHz and 5 MHz, or overlapping ranges thereof). In one embodiment, the first frequency is between 10 kHz and 100 kHz (for example, between 10 kHz and 30 kHz, between 15 kHz and 40 kHz, between 20 kHz and 50 kHz, between 30 kHz and 60 kHz, between 40 kHz and 80 kHz, between 50 kHz and 90 kHz, between 60 kHz and 100 kHz, overlapping ranges thereof, 20 kHz or any values from 10 kHz and 100 kHz) and the second frequency is between 400 kHz and 1000 kHz (for example, between 400 kHz and 600 kHz, between 450 kHz and 750 kHz, between 500 kHz and 800 kHz, between 600 kHz and 850 kHz, between 700 kHz and 900 kHz, between 800 kHz and 1000 kHz, overlapping ranges thereof, 800 kHz, or any values from 400 kHz to 1000 kHz) and the third frequency is between 20 kHz and 800 kHz. The predetermined threshold may be a value between 0.5 and 0.9. In some embodiments, generating a first output and generating a second output comprises causing the first output or the second output to be displayed on a display. The output may comprise textual information indicative of contact. In one embodiment, the output comprises a quantitative measurement and/or qualitative assessment of contact.

**[0159]** In some embodiments, the distal end portion of the medical instrument comprises a high-resolution electrode assembly comprising a first electrode portion and second electrode portion spaced apart and insulated from the first electrode portion (for example, a split-tip electrode assembly or combination radiofrequency electrode). The control unit may comprise a contact detection subsystem or module configured to receive signals from the high-resolution electrode assembly and the control unit (for example, processor) of the contact detection subsystem or module or a separate processor may be configured (for example, specifically programmed with instructions stored in or on a non-transitory computer-readable medium) to determine a level of contact or a contact state with tissue (for example, cardiac tissue) based on the received signals from the high-resolution electrode assembly and to modulate the opposition force provided by the opposition force motor based, at least in part, on the determined level of contact, or the contact state. The control unit may further comprise a power delivery module configured to apply radiofrequency power to the high-resolution electrode assembly at a level sufficient to

effect ablation of tissue in contact with at least a portion of the distal end portion of the medical instrument.

**[0160]** In some embodiments, the control unit (for example, processor) is configured to generate output indicative of the level of contact for display on a display coupled to the control unit (for example, via one or more display drivers). In various embodiments, the output is based on a contact function determined based on one or more criteria combining multiple electrical parameter measurements (such as voltage measurements, current measurements or impedance measurements). In one embodiment, the contact function is determined by summing a weighted combination of impedance (for example, bipolar impedance) measurements that are directly measured or that are calculated based on voltage and/or current measurements. In one embodiment, the contact function is based on one or more if-then case conditional criteria. In one embodiment, the impedance measurements comprise one or more of an impedance magnitude determined by the contact detection subsystem at a first frequency, a ratio of impedance magnitudes at the first frequency and a second frequency and a phase of a complex impedance measurement at the second frequency. The second frequency may be higher than the first frequency (for example, at least 20 kHz higher than the first frequency). In some embodiments, the first frequency and the second frequency are between 5 kHz and 1000 kHz. In one embodiment, the first frequency is between 10 kHz and 100 kHz (for example, between 10 kHz and 30 kHz, between 15 kHz and 40 kHz, between 20 kHz and 50 kHz, between 30 kHz and 60 kHz, between 40 kHz and 80 kHz, between 50 kHz and 90 kHz, between 60 kHz and 100 kHz, overlapping ranges thereof, 20 kHz or any values from 10 kHz and 100 kHz) and the second frequency is between 400 kHz and 1000 kHz (for example, between 400 kHz and 600 kHz, between 450 kHz and 750 kHz, between 500 kHz and 800 kHz, between 600 kHz and 850 kHz, between 700 kHz and 900 kHz, between 800 kHz and 1000 kHz, overlapping ranges thereof, 800 kHz, or any values from 400 kHz to 1000 kHz); however, other frequencies may be used as desired and/or required. In some embodiments, the frequencies at which impedance measurements are obtained are outside treatment (for example, ablation) frequency ranges. In some embodiments, filters (such as bandpass filters) are used to isolate the treatment frequency ranges from the impedance measurement frequency ranges.

**[0161]** In some embodiments, the handle of the medical instrument further comprises a motion detection element (for example, at least one of an accelerometer and a gyroscope). In some embodiments, the first motor is configured to be actuated only when the motion detection element is detecting motion of the handle.

**[0162]** In accordance with several embodiments, a method of determining a contact state of a distal end portion of a medical instrument with a target region, for example, tissue, comprises applying at least one signal having a plurality of frequencies to a pair of electrodes or electrode portions of a combination electrode assembly positioned along a distal end portion of a medical instrument. The method comprises processing a resulting waveform that formulates across the pair of electrodes to obtain a first impedance measurement at a first frequency of the plurality of frequencies and processing the resulting waveform that formulates across the pair of electrodes to obtain a second impedance measurement at a second frequency of the plurality of frequencies.

The method further comprises determining a magnitude of the first impedance measurement, determining a magnitude and a phase of the second impedance measurement and applying a contact function (for example, via execution of a computer program stored on a non-transitory computer storage medium) to calculate a contact indication value indicative of a state of contact between the distal end portion of the medical instrument and the target region (for example, cardiac tissue). The contact function may be determined by summing a weighted combination of the magnitude of the first impedance measurement, a ratio of the magnitudes of the first impedance measurement and the second impedance measurement, and the phase of the second impedance measurement. In various embodiments, the first frequency and the second frequency are different. In one embodiment, the second frequency is higher than the first frequency.

**[0163]** The method may further comprise generating output corresponding to the contact indication value for display on a display monitor (for example, via one or more display drivers). In some embodiments, the output comprises a qualitative and/or a quantitative output. The output may comprise a numerical value between 0 and 1 or between 0 and 1.5, with values above 1 indicating excessive contact. In some embodiments, the output comprises a percentage value or a number corresponding to an amount of contact force (for example, grams of contact force). The output may comprise a color and/or pattern indicative of the contact state and/or one or more of a gauge, a bar, or a scale.

**[0164]** In accordance with several embodiments, a system for determining a contact state of a distal end portion of a medical instrument with a target region (for example, tissue, based, at least in part, on electrical parameter measurements consists essentially of or comprises a signal source configured to generate at least one signal having a first frequency and a second frequency to be applied to a pair of electrode members of a combination electrode assembly (for example, two electrode members separated by a gap). The system also consists essentially of or comprises a processing device configured to (a) cause the signal source to generate and apply the at least one signal to the pair of electrode members, (b) process a resulting waveform that formulates across the pair of electrode members to obtain a first electrical measurement at the first frequency, (c) process the resulting waveform that formulates across the pair of electrode members to obtain a second electrical measurement at the second frequency of the plurality of frequencies, (d) determine an impedance magnitude based on the first electrical measurement, (e) determine an impedance magnitude and a phase based on the second electrical measurement, and (f) calculate a contact indication value indicative of a state of contact between the distal end portion of the medical instrument and the target region based on a criterion combining the impedance magnitude based on the first electrical measurement, a ratio of the impedance magnitudes based on the first and second electrical measurements, and the phase based on the second electrical measurement. The electrical measurements may comprise voltage, current, and/or other electrical parameter measurements from which impedance measurements (such as impedance magnitude or phase) may be calculated or may comprise directly-obtained impedance measurements. The criterion may comprise a weighted combination of the impedance magnitude based on the first electrical measurement, a ratio of the impedance magnitudes based on the first and second electrical measurements, and

the phase based on the second electrical measurement or the criterion may comprise an if-then case conditional criterion.

**[0165]** In some embodiments, the system further comprises the medical instrument, which may be a radiofrequency ablation catheter. The first frequency and the second frequency may be different. In some embodiments, the second frequency is higher than the first frequency. In other embodiments, the second frequency is lower than the first frequency. In some embodiments, the first frequency and the second frequency are between 5 kHz and 1000 kHz (for example, between 5 kHz and 50 kHz, between 10 kHz and 100 kHz, between 50 kHz and 200 kHz, between 100 kHz and 500 kHz, between 200 kHz and 800 kHz, between 400 kHz and 1000 kHz, or overlapping ranges thereof). In various embodiments, the two frequencies are at least 20 kHz apart in frequency.

**[0166]** In some embodiments, the processor is further configured to generate output corresponding to the contact indication value for display on a display monitor, upon execution of specific instructions stored in or on a computer-readable medium. In some embodiments, the output comprises a numerical value between 0 and 1. In some embodiments, the output comprises a qualitative output (such as a color and/or pattern indicative of the contact state). In some embodiments, the output comprises one or more of a gauge, a bar, a meter or a scale. In one embodiment, the output comprises a virtual gauge having a plurality of regions (for example, two, three, four, five or more than five regions or segments) indicative of varying levels of contact, or contact states. The plurality of regions may be represented in different colors. Each of the plurality of regions may correspond to a different range of numerical values indicative of varying levels of contact.

**[0167]** In accordance with several embodiments, a system for displaying a contact state of a distal tip of a medical instrument with a target region (for example, body tissue) on a patient monitor comprises a processor configured to generate output for display on the patient monitor. The output may be generated on a graphical user interface on the patient monitor. In one embodiment, the output comprises a graph that displays a contact function indicative of a contact state between a distal tip of a medical instrument and body tissue calculated by a processing device based, at least in part, on impedance measurements obtained by the medical instrument. The graph may be a scrolling waveform. The output also comprises a gauge separate from the graph that indicates a real-time state of contact corresponding to a real-time numerical value of the contact function displayed by the graph. The gauge includes a plurality of regions indicative of varying contact states. In some embodiments, each one of the plurality of regions is optionally displayed in a different color or graduation to provide a qualitative indication of the real-time state of contact. In one embodiment, the gauge consists of three regions or segments. The three regions may be colored red, yellow and green. In another embodiment, the gauge consists of four regions or segments. The four regions may be colored red, orange, yellow and green. Each of the plurality of regions may correspond to a different range of numerical values indicative of the current contact state. The gauge may comprise a pointer that indicates a level on the gauge corresponding to the real-time numerical value of the contact function. The real-time numerical value may range between 0 and 1 or between 0 and 1.25 or between 0 and 1.5. Values above 1 may generate a “contact

alert” to the clinician to prevent excessive contact, which could result in perforation of tissue.

**[0168]** The output may also comprise other graphs or waveforms of individual components of impedance measurements (for example, impedance magnitude and phase) at multiple frequencies or of comparisons (for example, a slope) between two impedance measurements (for example, impedance magnitude at two different frequencies).

**[0169]** In some embodiments, the contact function is calculated based on a weighted combination of a magnitude of a first impedance measurement at a first frequency, a ratio of the magnitudes of the first impedance measurement and a second impedance measurement at a second frequency different from the first frequency, and the phase of the second impedance measurement at the second frequency. In one embodiment, the second frequency is higher than the first frequency. In another embodiment, the second frequency is lower than the first frequency. The first frequency and the second frequency may be between 5 kHz and 1000 kHz. In some embodiments, the system further comprises the patient monitor.

**[0170]** In accordance with several embodiments, a system for assessing a level of contact between a distal end portion of an ablation catheter having a pair of spaced-apart electrode members of a combination electrode assembly and target region, e.g., tissue, comprises a signal source configured to generate signals having at least a first frequency and a second frequency to be applied to the pair of spaced-apart electrode members. The system also comprises a processor configured to, upon execution of specific program instructions stored on a computer-readable storage medium, measure network parameters at an input of a network measurement circuit comprising a plurality of hardware components between the signal source and the pair of spaced-apart electrode members. The processor may also be configured (for example, specifically programmed, constructed or designed) to determine an aggregate effect on a measured network parameter value caused by the hardware components of the network measurement circuit, remove the aggregate effect to result in a corrected network parameter value between the pair of spaced-apart electrode members, and determine a level of contact based, at least in part, on the corrected network parameter value.

**[0171]** In some embodiments, the processor is configured to generate an output indicative of the level of contact for display. The signal source may be located within a radio-frequency generator or within the ablation catheter. The processor may be configured to measure network parameters at at least two frequencies (for example, two frequencies, three frequencies, four frequencies or more than four frequencies). In some embodiments, the frequencies are between 5 kHz and 1000 kHz. In embodiments involving two frequencies, the second frequency may be at least 20 kHz higher than the first frequency. For example, the first frequency may be between 10 kHz and 100 kHz and the second frequency is between 400 kHz and 1000 kHz. A third frequency may be higher than the first frequency and lower than the second frequency (for example, the third frequency may be between 20 kHz and 120 kHz.).

**[0172]** The network parameters may comprise scattering parameters or other electrical parameters (such as voltage, current, impedance). The network parameter values may comprise, for example, voltage and current values or impedance values either directly measured or determined from

voltage and/or current values. Impedance values may comprise impedance magnitude values and impedance phase values. The impedance magnitude values may be obtained at two or more frequencies and slopes may be determined between magnitude values at different frequencies. The impedance phase values may be obtained at one or more frequencies.

**[0173]** In accordance with several embodiments, a method of assessing a level of contact determination of a distal end portion of an ablation catheter having a pair of spaced-apart electrode members comprises measuring network parameters at an input of a network parameter circuit of hardware components between a signal source and the pair of spaced-apart electrode members. The method also comprises determining an aggregate effect on a measured network parameter value determined from the network parameters caused by the hardware components, removing the aggregate effect to result in a corrected network parameter value between the pair of spaced-apart electrode members, and determining a level of contact based, at least in part, on the corrected network parameter value.

**[0174]** Measuring network parameters may comprise measuring network parameters at a plurality of frequencies. In some embodiments, determining an aggregate effect on the measured network parameter value caused by the hardware components of the network parameter circuit comprises measuring network parameters associated with each individual hardware component. In some embodiments, determining an aggregate effect on the measured network parameter value caused by the hardware components of the network parameter circuit comprises combining the network parameters of the individual hardware components into total network parameters at a plurality of frequencies. Removing the aggregate effect so as to isolate an actual network parameter value between the pair of spaced-apart electrode members may comprise de-embedding the total network parameters from a measured input reflection coefficient to result in an actual reflection coefficient corresponding to the actual network parameter value. In some embodiments, the method is performed automatically by a processor.

**[0175]** The processing device (for example, processor or controller) may be configured to perform operations recited herein upon execution of instructions stored within memory or a non-transitory storage medium. The methods summarized above and set forth in further detail below may describe certain actions taken by a practitioner; however, it should be understood that they can also include the instruction of those actions by another party. For example, actions such as “terminating energy delivery” include “instructing the terminating of energy delivery.” Further aspects of embodiments of the invention will be discussed in the following portions of the specification. With respect to the drawings, elements from one figure may be combined with elements from the other figures.

**[0176]** According to some embodiments, an ablation system consists essentially of a catheter, an ablation member (e.g., a RF electrode, a split-tip electrode, another type of high-resolution electrode, etc.), an irrigation conduit extending through an interior of the catheter to or near the ablation member, at least one electrical conductor (e.g., wire, cable, etc.) to selectively activate the ablation member and at least one heat transfer member that places at least a portion of the ablation member (e.g., a proximal portion of the ablation member) in thermal communication with the irrigation con-

duit, at least one heat shunt member configured to effectively transfer heat away from the electrode and/or tissue being treated and a plurality of temperature sensors (e.g., thermocouples) located along two different longitudinal locations of the catheter, wherein the temperature sensors are thermally isolated from the electrode and configured to detect temperature of tissue at a depth.

[0177] The methods summarized above and set forth in further detail below may describe certain actions taken by a practitioner; however, it should be understood that they can also include the instruction of those actions by another party. For example, actions such as “terminating energy delivery” include “instructing the terminating of energy delivery.” Further aspects of embodiments of the invention will be discussed in the following portions of the specification. With respect to the drawings, elements from one figure may be combined with elements from the other figures.

#### BRIEF DESCRIPTION OF THE DRAWINGS

[0178] These and other features, aspects and advantages of the present application are described with reference to drawings of certain embodiments, which are intended to illustrate, but not to limit, the concepts disclosed herein. The attached drawings are provided for the purpose of illustrating concepts of at least some of the embodiments disclosed herein and may not be to scale.

[0179] FIG. 1 schematically illustrates one embodiment of an energy delivery system configured to selectively ablate or otherwise heat targeted tissue of a subject;

[0180] FIG. 2 illustrates a side view of a system's catheter comprising a high-resolution-tip design according to one embodiment;

[0181] FIG. 3 illustrates a side view of a system's catheter comprising a high-resolution-tip design according to another embodiment;

[0182] FIG. 4 illustrates a side view of a system's catheter comprising a high-resolution-tip design according to yet another embodiment;

[0183] FIG. 5 illustrates an embodiment of a system's catheter comprising two high-resolution-section electrodes each consisting of separate sections circumferentially distributed on the catheter shaft;

[0184] FIG. 6 schematically illustrates one embodiment of a high-pass filtering element consisting of a coupling capacitor. The filtering element can be incorporated into a system's catheter that comprises a high-resolution-tip design;

[0185] FIG. 7 schematically illustrates one embodiment of four high-pass filtering elements comprising coupling capacitors. The filtering elements can operatively couple, in the operating RF frequency range, the separate electrode sections of a system's catheter electrodes, e.g., those illustrated in FIG. 5;

[0186] FIG. 8 illustrates embodiments of EKGs obtained from a high-resolution-tip electrode systems disclosed herein configured to detect whether an ablation procedure has been adequately performed;

[0187] FIG. 9 illustrates a perspective view of an ablation system's catheter comprising an electrode and heat shunt network to facilitate the transfer of heat to an irrigation conduit during use, according to one embodiment;

[0188] FIG. 10 illustrates a partially exposed view of the system of FIG. 9;

[0189] FIG. 11 illustrates a perspective view of an ablation system's catheter comprising an electrode and heat shunt

network to facilitate the transfer of heat to an irrigation conduit during use, according to another embodiment;

[0190] FIG. 12 illustrates a cross-sectional view of an ablation system's catheter comprising an electrode and heat shunt network to facilitate the transfer of heat to an irrigation conduit during use, according to one embodiment;

[0191] FIG. 13 illustrates a partial cross-sectional perspective view of one embodiment of an ablation system's catheter comprising an open irrigation cooling system;

[0192] FIG. 14 illustrates a partial cross-sectional perspective view of one embodiment of an ablation system's catheter comprising a closed irrigation cooling system;

[0193] FIG. 15 illustrates a partial cross-sectional perspective view of another embodiment of an ablation system's catheter;

[0194] FIG. 16A illustrates a side perspective view of a distal end of one embodiment of a split-tip RF ablation system comprising heat transfer (e.g. heat shunt) members;

[0195] FIG. 16B illustrates a partial cross-sectional perspective view of the system of FIG. 16A;

[0196] FIG. 16C illustrates a partial cross-sectional perspective view of another embodiment of an ablation system comprising a split-tip electrode and heat transfer (e.g. heat shunt) members;

[0197] FIG. 17A illustrates a side perspective view of a distal end of one embodiment of a split-tip RF ablation system comprising heat transfer (e.g. heat shunt) members and fluid outlets extending through a proximal electrode or slug;

[0198] FIG. 17B illustrates a partial cross-sectional perspective view of the system of FIG. 17A;

[0199] FIG. 18A illustrates a perspective view of a distal portion of an open-irrigated ablation catheter having multiple temperature-measurement devices, according to one embodiment;

[0200] FIGS. 18B and 18C illustrate a perspective view and a cross-sectional view, respectively, of a distal portion of an open-irrigated ablation catheter having multiple temperature-measurement devices, according to another embodiment;

[0201] FIG. 18D illustrates a perspective view of a distal portion of an ablation catheter having multiple temperature-measurement devices, according to another embodiment;

[0202] FIGS. 18E and 18F illustrate a perspective view and a cross-sectional view, respectively, of a distal portion of an ablation catheter showing isolation of the distal temperature-measurement devices from an electrode tip, according to one embodiment;

[0203] FIG. 19A illustrates a perspective view of a distal portion of a closed-irrigation ablation catheter having multiple temperature-measurement devices, according to one embodiment;

[0204] FIGS. 19B and 19C illustrate a perspective view and a cross-sectional view, respectively, of a distal portion of a closed-irrigation ablation catheter having multiple temperature-measurement devices, according to another embodiment;

[0205] FIG. 20 illustrates a perspective view of a distal portion of an open-irrigated ablation catheter comprising a non-split-tip design according to one embodiment;

[0206] FIG. 21A schematically illustrates a distal portion of an open-irrigated ablation catheter in contact with tissue

to be ablated in a perpendicular orientation and a lesion formed using the ablation catheter, according to one embodiment;

[0207] FIG. 21B schematically illustrates a distal portion of an open-irrigated ablation catheter in contact with tissue to be ablated in a parallel orientation and a lesion formed using the ablation catheter, according to one embodiment;

[0208] FIG. 22A is a graph illustrating that temperature of a lesion peak may be correlated to the temperature of the temperature-measurement devices by a correction factor or function, according to one embodiment;

[0209] FIG. 22B is a plot showing an estimated peak temperature determined by an embodiment of an ablation catheter having multiple temperature-measurement devices compared against actual tissue measurements at various depths within a tissue;

[0210] FIGS. 23A and 23B illustrate plots showing temperature measurements obtained by the multiple temperature-measurement devices of an embodiment of an ablation catheter for a parallel orientation and an oblique orientation, respectively;

[0211] FIG. 24 schematically illustrates one embodiment of variable frequency being applied to the split-tip electrode design of FIG. 2 to determine whether the split-tip electrode is in contact with tissue;

[0212] FIG. 25A is a plot showing normalized resistance of blood/saline and tissue across a range of frequencies;

[0213] FIG. 25B is a plot of a four tone waveform utilized for impedance measurements;

[0214] FIG. 25C is a plot of impedance vs. frequency, with tones at four frequencies;

[0215] FIG. 25D schematically illustrates one embodiment of a contact sensing subsystem configured to perform contact sensing functions while simultaneously conducting electrogram (EGM) measurements, in accordance with one embodiment;

[0216] FIG. 26A illustrates zero crossings of a frequency spectrum and is used to illustrate that switching between frequencies may be designed to occur at the zero crossings to avoid interference at EGM frequencies;

[0217] FIG. 26B schematically illustrates one embodiment of a circuit model to describe the behavior of the impedance of tissue or blood or blood/saline combination, as measured across two electrodes or electrode portions;

[0218] FIG. 26C schematically illustrates one embodiment of a circuit configured to switch between contact sensing circuitry in standby mode and radiofrequency energy delivery circuitry in treatment mode, in accordance with one embodiment;

[0219] FIG. 27 schematically illustrates one embodiment of a circuit configured to perform contact sensing functions while radiofrequency energy is being delivered, in accordance with one embodiment;

[0220] FIG. 28 is a plot of impedance of an LC circuit element across a range of frequencies;

[0221] FIG. 29 is a plot showing resistance, or impedance magnitude, values of ablated tissue, viable tissue and blood across a range of frequencies;

[0222] FIG. 30 is a plot showing the phase of impedance values of ablated tissue, viable tissue and blood across a range of frequencies;

[0223] FIG. 31 illustrates one embodiment of a sensing algorithm that utilizes impedance magnitude, ratio of imped-

ance magnitude at two frequencies, and impedance phase data to determine contact state as well as tissue state;

[0224] FIG. 32 illustrates an embodiment of a contact criterion process, and FIG. 32A illustrates an embodiment of a sub-process of the contact criterion process of FIG. 32;

[0225] FIG. 33 illustrates an embodiment of a graphical user interface of a display of output indicative of tissue contact by a high resolution combination electrode device;

[0226] FIG. 34A illustrates a schematic representation of possible hardware components of a network measurement circuit;

[0227] FIG. 34B illustrates a schematic representation of an embodiment of an auto-calibration circuit configured to calibrate (for example, automatically) the network measurement circuit so as to remove the effects of one or more hardware components present in the circuit; and

[0228] FIG. 34C illustrates a schematic representation of one embodiment of an equivalent circuit model for a hardware component present in an impedance measurement circuit.

#### DETAILED DESCRIPTION

[0229] According to some embodiments, successful electrophysiology procedures require precise knowledge about the anatomic substrate being targeted. Additionally, it may be desirable to evaluate the outcome of an ablation procedure within a short period of time after the execution of the procedure (e.g., to confirm that the desired clinical outcome was achieved). Typically, ablation catheters include only regular mapping electrodes (e.g., ECG electrodes). However, in some embodiments, it may be desirable for such catheters to incorporate high-resolution mapping capabilities. In some embodiments, high-resolution mapping electrodes can provide more accurate and more detailed information about the anatomic substrate and about the outcome of ablation procedures. For example, such high-resolution mapping electrodes can allow the electrophysiology (EP) practitioner to evaluate the morphology of electrograms, their amplitude and width and/or to determine changes in pacing thresholds. According to some arrangements, morphology, amplitude and/or pacing threshold are accepted as reliable EP markers that provide useful information about the outcome of ablation. Thus, high-resolution electrodes are defined as any electrode(s) capable of delivering ablative or other energy to tissue capable of transferring heat to/from such tissue, while being capable of obtaining accurate mapping data of adjacent tissue, and include, without limitation, split-tip RF electrodes, other closely oriented electrodes or electrode portions and/or the like.

[0230] According to some embodiments, the present application discloses devices, systems and/or methods that include one or more of the following features: a high-resolution electrode (e.g., split tip electrode), heat shunting concepts to help dissipate heat away from the electrode and/or the tissue of the subject being treated, multiple temperature sensors located along the exterior of the device to determine, among other things, temperature of the subject at a depth and contact sensing features that help determine if and to what extent the device is contacting targeted tissue.

[0231] Several embodiments of the invention are particularly advantageous because they include one, several or all of the following benefits: (i) provides the ability to obtain accurate tissue mapping data using the same electrode that delivers the ablative energy, (ii) reduces proximal edge

heating, (iii) reduces likelihood of char or thrombus formation, (iv) provides feedback that may be used to adjust ablation procedures in real time, (v) provides noninvasive temperature measurements, (vi) does not require use of radiometry; (vii) provides tissue temperature monitoring and feedback during irrigated or non-irrigated ablation; and (viii) provides multiple forms of output or feedback to a user; and (ix) provides safer and more reliable ablation procedures.

#### High-Resolution Electrode

[0232] According to some embodiments, various implementations of electrodes (e.g., radiofrequency or RF electrodes) that can be used for high-resolution mapping are disclosed herein. For example, as discussed in greater detail herein, an ablation or other energy delivery system can comprise a high-resolution-tip design, wherein the energy delivery member (e.g., radiofrequency electrode) comprises two or more separate electrodes or electrode portions. As also discussed herein, in some embodiments, such separate electrodes or electrode portions can be advantageously electrically coupled to each other (e.g., to collectively create the desired heating or ablation of targeted tissue).

[0233] FIG. 1 schematically illustrates one embodiment of an energy delivery system 10 that is configured to selectively ablate, stimulate, modulate and/or otherwise heat or treat targeted tissue (e.g., cardiac tissue, pulmonary vein, other vessels or organs, etc.). Although certain embodiments disclosed herein are described with reference to ablation systems and methods, any of the systems and methods can be used to stimulate, modulate, heat and/or otherwise affect tissue, with or without partial or complete ablation, as desired or required. As shown, the system 10 can include a medical instrument 20 (e.g., catheter) comprising one or more energy delivery members 30 (e.g., radiofrequency electrodes) along a distal end of the medical instrument 20. The medical instrument can be sized, shaped and/or otherwise configured to be passed intraluminally (e.g., intravascularly) through a subject being treated. In various embodiments, the medical instrument 20 comprises a catheter, a shaft, a wire, and/or other elongate instrument. In other embodiments, the medical instrument is not positioned intravascularly but is positioned extravascularly via laparoscopic or open surgical procedures. In various embodiments, the medical instrument 20 comprises a catheter, a shaft, a wire, and/or other elongate instrument. In some embodiments, one or more temperature sensing devices or systems 60 (e.g., thermocouples, thermistors, etc.) may be included at the distal end of the medical instrument 20, or along its elongate shaft or in its handle. The term "distal end" does not necessarily mean the distal terminus or distal end. Distal end could mean the distal terminus or a location spaced from the distal terminus but generally at a distal end portion of the medical instrument 20.

[0234] In some embodiments, the medical instrument 20 is operatively coupled to one or more devices or components. For example, as depicted in FIG. 1, the medical instrument 20 can be coupled to a delivery module 40 (such as an energy delivery module). According to some arrangements, the energy delivery module 40 includes an energy generation device 42 that is configured to selectively energize and/or otherwise activate the energy delivery member(s) 30 (for example, radiofrequency electrodes) located along the medical instrument 20. In some embodiments, for instance, the energy generation device 42 comprises a radiofrequency

generator, an ultrasound energy source, a microwave energy source, a laser/light source, another type of energy source or generator, and the like, and combinations thereof. In other embodiments, energy generation device 42 is substituted with or use in addition to a source of fluid, such a cryogenic fluid or other fluid that modulates temperature. Likewise, the delivery module (e.g., delivery module 40), as used herein, can also be a cryogenic device or other device that is configured for thermal modulation.

[0235] With continued reference to the schematic of FIG. 1, the energy delivery module 40 can include one or more input/output devices or components 44, such as, for example, a touchscreen device, a screen or other display, a controller (e.g., button, knob, switch, dial, etc.), keypad, mouse, joystick, trackpad, or other input device and/or the like. Such devices can permit a physician or other user to enter information into and/or receive information from the system 10. In some embodiments, the output device 44 can include a touchscreen or other display that provides tissue temperature information, contact information, other measurement information and/or other data or indicators that can be useful for regulating a particular treatment procedure.

[0236] According to some embodiments, the energy delivery module 40 includes a processor 46 (e.g., a processing or control unit) that is configured to regulate one or more aspects of the treatment system 10. The module 40 can also comprise a memory unit or other storage device 48 (e.g., computer readable medium) that can be used to store operational parameters and/or other data related to the operation of the system 10. In some embodiments, the processor 46 is configured to automatically regulate the delivery of energy from the energy generation device 42 to the energy delivery member 30 of the medical instrument 20 based on one or more operational schemes. For example, energy provided to the energy delivery member 30 (and thus, the amount of heat transferred to or from the targeted tissue) can be regulated based on, among other things, the detected temperature of the tissue being treated.

[0237] According to some embodiments, the energy delivery system 10 can include one or more temperature detection devices, such as, for example, reference temperature devices (e.g., thermocouples, thermistors, etc.) and/or the like. For example, in some embodiments, the device further comprises a one or more temperature sensors or other temperature-measuring devices to help determine a peak (e.g., high or peak, low or trough, etc.) temperature of tissue being treated. In some embodiments, the temperature sensors (e.g., thermocouples) located at, along and/or near the ablation member (e.g., RF electrode) can help with the determination of whether contact is being made between the ablation member and targeted tissue (and/or to what degree such contact is being made). In some embodiments, such peak temperature is determined without the use of radiometry. Additional details regarding the use of temperature sensors (e.g., thermocouples) to determine peak tissue temperature and/or to confirm or evaluate tissue contact are provided herein.

[0238] With reference to FIG. 1, the energy delivery system 10 comprises (or is in configured to be placed in fluid communication with) an irrigation fluid system 70. In some embodiments, as schematically illustrated in FIG. 1, such a fluid system 70 is at least partially separate from the energy delivery module 40 and/or other components of the system 10. However, in other embodiments, the irrigation fluid

system 70 is incorporated, at least partially, into the energy delivery module 40. The irrigation fluid system 70 can include one or more pumps or other fluid transfer devices that are configured to selectively move fluid through one or more lumens or other passages of the catheter 20. Such fluid can be used to selectively cool (e.g., transfer heat away from) the energy delivery member 30 during use.

[0239] FIG. 2 illustrates one embodiment of a distal end of a medical instrument (e.g., catheter) 20. As shown, the catheter 20 can include a high-resolution tip design, such that there are two adjacent electrodes or two adjacent electrode portions 30A, 30B separated by a gap G. According to some embodiments, as depicted in the configuration of FIG. 2, the relative length of the different electrodes or electrode portions 30A, 30B can vary. For example, the length of the proximal electrode 30B can be between 1 to 20 times (e.g., 1-2, 2-3, 3-4, 4-5, 5-6, 6-7, 7-8, 8-9, 9-10, 10-11, 11-12, 12-13, 13-14, 14-15, 15-16, 16-17, 17-18, 18-19, 19-20, values between the foregoing ranges, etc.) the length of the distal electrode 30A, as desired or required. In other embodiments, the length of the proximal electrode 30B can be greater than 20 times (e.g., 20-25, 25-30, more than 30 times, etc.) the length of the distal electrode 30A. In yet other embodiments, the lengths of the distal and proximal electrodes 30A, 30B are about equal. In some embodiments, the distal electrode 30A is longer than the proximal electrode 30B (e.g., by 1 to 20 times, such as, for example, 1-2, 2-3, 3-4, 4-5, 5-6, 6-7, 7-8, 8-9, 9-10, 10-11, 11-12, 12-13, 13-14, 14-15, 15-16, 16-17, 17-18, 18-19, 19-20, values between the foregoing ranges, etc.).

[0240] In some embodiments, the distal electrode or electrode portion 30A is 0.5 mm long. In other embodiments, the distal electrode or electrode portion 30A is between 0.1 mm and 1 mm long (e.g., 0.1-0.2, 0.2-0.3, 0.3-0.4, 0.4-0.5, 0.5-0.6, 0.6-0.7, 0.7-0.8, 0.8-0.9, 0.9-1 mm, values between the foregoing ranges, etc.). In other embodiments, the distal electrode or electrode portion 30A is greater than 1 mm in length, as desired or required. In some embodiments, the proximal electrode or electrode portion 30B is 2 to 4 mm long (e.g., 2-2.5, 2.5-3, 3-3.5, 3.5-4 mm, lengths between the foregoing, etc.). However, in other embodiments, the proximal electrode portion 30B is greater than 4 mm (e.g., 4-5, 5-6, 6-7, 7-8, 8-9, 9-10 mm, greater than 10 mm, etc.) or smaller than 1 mm (e.g., 0.1-0.5, 0.5-1, 1-1.5, 1.5-2 mm, lengths between the foregoing ranges, etc.), as desired or required. In embodiments where the high-resolution electrodes are located on catheter shafts, the length of the electrodes can be 1 to 5 mm (e.g., 1-2, 2-3, 3-4, 4-5 mm, lengths between the foregoing, etc.). However, in other embodiments, the electrodes can be longer than 5 mm (e.g., 5-6, 6-7, 7-8, 8-9, 9-10, 10-15, 15-20 mm, lengths between the foregoing, lengths greater than 20 mm, etc.), as desired or required.

[0241] As noted above, the use of a high-resolution tip design can permit a user to simultaneously ablate or otherwise thermally treat targeted tissue and map (e.g., using high-resolution mapping) in a single configuration. Thus, such systems can advantageously permit precise high-resolution mapping (e.g., to confirm that a desired level of treatment occurred) during a procedure. In some embodiments, the high-resolution tip design that includes two electrodes or electrode portions 30A, 30B can be used to record a high-resolution bipolar electrogram. For such purposes, the two electrodes or electrode portions can be

connected to the inputs of an EP recorder. In some embodiments, a relatively small separation distance (e.g., gap G) between the electrodes or electrode portions 30A, 30B enables high-resolution mapping.

[0242] In some embodiments, a medical instrument (e.g., a catheter) 20 can include three or more electrodes or electrode portions (e.g., separated by gaps), as desired or required. Additional details regarding such arrangements are provided below. According to some embodiments, regardless of how many electrodes or electrode portions are positioned along a catheter tip, the electrodes or electrode portions 30A, 30B are radiofrequency electrodes and comprise one or more metals, such as, for example, stainless steel, platinum, platinum-iridium, gold, gold-plated alloys and/or the like.

[0243] According to some embodiments, as illustrated in FIG. 2, the electrodes or electrode portions 30A, 30B are spaced apart from each other (e.g., longitudinally or axially) using a gap (e.g., an electrically insulating gap). In some embodiments, the length of the gap G (or the separation distance between adjacent electrodes or electrode portions) is 0.5 mm. In other embodiments, the gap G or separation distance is greater or smaller than 0.5 mm, such as, for example, 0.1-1 mm (e.g., 0.1-0.2, 0.2-0.3, 0.3-0.4, 0.4-0.5, 0.5-0.6, 0.6-0.7, 0.7-0.8, 0.8-0.9, 0.9-1.0 mm, values between the foregoing ranges, less than 0.1 mm, greater than 1 mm, etc.), as desired or required.

[0244] According to some embodiments, a separator 34 is positioned within the gap G, between the adjacent electrodes or electrode portions 30A, 30B, as depicted in FIG. 2. The separator can comprise one or more electrically insulating materials, such as, for example, Teflon, polyetheretherketone (PEEK), polyetherimide resins (e.g., ULTEM™), ceramic materials, polyimide and the like.

[0245] As noted above with respect to the gap G separating the adjacent electrodes or electrode portion, the insulating separator 34 can be 0.5 mm long. In other embodiments, the length of the separator 34 can be greater or smaller than 0.5 mm (e.g., 0.1-0.2, 0.2-0.3, 0.3-0.4, 0.4-0.5, 0.5-0.6, 0.6-0.7, 0.7-0.8, 0.8-0.9, 0.9-1.0 mm, values between the foregoing ranges, less than 0.1 mm, greater than 1 mm, etc.), as desired or required.

[0246] According to some embodiments, as discussed in greater detail herein, to ablate or otherwise heat or treat targeted tissue of a subject successfully with the high-resolution tip electrode design, such as the one depicted in FIG. 2, the two electrodes or electrode portions 30A, 30B are electrically coupled to each other at the RF frequency. Thus, the two electrodes or electrode portions can advantageously function as a single longer electrode at the RF frequency.

[0247] FIGS. 3 and 4 illustrate different embodiments of catheter systems 100, 200 that incorporate a high-resolution tip design. For example, in FIG. 3, the electrode (e.g., radiofrequency electrode) along the distal end of the electrode comprises a first or distal electrode or electrode portion 110 and a second or proximal electrode or electrode portion 114. As shown and discussed in greater detail herein with reference to other configurations, the high-resolution tip design 100 includes a gap G between the first and second electrodes or electrode portions 110, 114. In some configurations, the second or proximal electrode or electrode portion 114 is generally longer than the first or distal electrode or electrode portion 110. For instance, the length of the

proximal electrode **114** can be between 1 to 20 times (e.g., 1-2, 2-3, 3-4, 4-5, 5-6, 6-7, 7-8, 8-9, 9-10, 10-11, 11-12, 12-13, 13-14, 14-15, 15-16, 16-17, 17-18, 18-19, 19-20, values between the foregoing ranges, etc.) the length of the distal electrode **110**, as desired or required. In other embodiments, the length of the proximal electrode can be greater than 20 times (e.g., 20-25, 25-30, more than 30 times, etc.) the length of the distal electrode. In yet other embodiments, the lengths of the distal and proximal electrodes are about the same. However, in some embodiments, the distal electrode **110** is longer than the proximal electrode **114** (e.g., by 1 to 20 times, such as, for example, 1-2, 2-3, 3-4, 4-5, 5-6, 6-7, 7-8, 8-9, 9-10, 10-11, 11-12, 12-13, 13-14, 14-15, 15-16, 16-17, 17-18, 18-19, 19-20, values between the foregoing ranges, etc.).

[0248] As shown in FIG. 3 and noted above, regardless of their exact design, relative length diameter, orientation and/or other characteristics, the electrodes or electrode portions **110**, **114** can be separated by a gap G. The gap G can comprise a relatively small electrically insulating gap or space. In some embodiments, an electrically insulating separator **118** can be snugly positioned between the first and second electrodes or electrode portions **110**, **114**. In certain embodiments, the separator **118** can have a length of about 0.5 mm. In other embodiments, however, the length of the separator **118** can be greater or smaller than 0.5 mm (e.g., 0.1-0.2, 0.2-0.3, 0.3-0.4, 0.4-0.5, 0.5-0.6, 0.6-0.7, 0.7-0.8, 0.8-0.9, 0.9-1.0 mm, values between the foregoing ranges, less than 0.1 mm, greater than 1 mm, etc.), as desired or required. The separator can include one or more electrically insulating materials (e.g., materials that have an electrical conductivity less than about 1000 or less (e.g., 500-600, 600-700, 700-800, 800-900, 900-1000, 1000-1100, 1100-1200, 1200-1300, 1300-1400, 1400-1500, values between the foregoing, less than 500, greater than 1500, etc.) than the electrical conductivity of metals or alloys). The separator can comprise one or more electrically insulating materials, such as, for example, Teflon, polyetheretherketone (PEEK), polyoxymethylene, acetal resins or polymers and the like.

[0249] As shown in FIG. 3, the separator **118** can be cylindrical in shape and can have the identical or similar diameter and configuration as the adjacent electrodes or electrode portions **110**, **114**. Thus, in some embodiments, the outer surface formed by the electrodes or electrode portions **110**, **114** and the separator **118** can be generally uniform or smooth. However, in other embodiments, the shape, size (e.g., diameter) and/or other characteristics of the separator **118** can be different than one or more of the adjacent electrodes or electrode portions **110**, **114**, as desired or required for a particular application or use.

[0250] FIG. 4 illustrates an embodiment of a system **200** having three or more electrodes or electrode portions **210**, **212**, **214** separated by corresponding gaps G1, G2. The use of such additional gaps, and thus, additional electrodes or electrode portions **210**, **212**, **214** that are physically separated (e.g., by gaps) yet in close proximity to each other, can provide additional benefits to the high-resolution mapping capabilities of the system. For example, the use of two (or more) gaps can provide more accurate high-resolution mapping data related to the tissue being treated. Such multiple gaps can provide information about the directionality of cardiac signal propagation. In addition, high-resolution mapping with high-resolution electrode portions involving multiple gaps can provide a more extended view of lesion

progression during the ablation process and higher confidence that viable tissue strands are not left behind within the targeted therapeutic volume. In some embodiments, high-resolution electrodes with multiple gaps can optimize the ratio of mapped tissue surface to ablated tissue surface. Preferably, such ratio is in the range of 0.2 to 0.8 (e.g., 0.2-0.3, 0.3-0.4, 0.4-0.5, 0.5-0.6, 0.6-0.7, 0.7-0.8, ratios between the foregoing, etc.). Although FIG. 4 illustrates an embodiment having a total of three electrodes or electrode portions **210**, **212**, **214** (and thus, two gaps G1, G2), a system can be designed or otherwise modified to comprise additional electrodes or electrode portions, and thus, additional gaps. For example, in some embodiments, an ablation or other treatment system can include 4 or more (e.g., 5, 6, 7, 8, more than 8, etc.) electrodes or electrode portions (and thus, 3 or more gaps, e.g., 3, 4, 5, 6, 7 gaps, more than 7 gaps, etc.), as desired or required. In such configurations, a gap (and/or an electrical separator) can be positioned between adjacent electrodes or electrode portions, in accordance with the embodiments illustrated in FIGS. 2 to 4.

[0251] As depicted in FIGS. 3 and 4, an irrigation tube **120**, **220** can be routed within an interior of the catheter (not shown for clarity). In some embodiments, the irrigation tube **120**, **220** can extend from a proximal portion of the catheter (e.g., where it can be placed in fluid communication with a fluid pump) to the distal end of the system. For example, in some arrangements, as illustrated in the side views of FIGS. 3 and 4, the irrigation tube **120**, **220** extends and is in fluid communication with one or more fluid ports **211** that extend radially outwardly through the distal electrode **110**, **210**. Thus, in some embodiments, the treatment system comprises an open irrigation design, wherein saline and/or other fluid is selectively delivered through the catheter (e.g., within the fluid tube **120**, **220**) and radially outwardly through one or more outlet ports **111**, **211** of an electrode **110**, **210**. The delivery of such saline or other fluid can help remove heat away from the electrodes and/or the tissue being treated. In some embodiments, such an open irrigation system can help prevent overheating of targeted tissue, especially along the tissue that is contacted by the electrodes. An open irrigation design is also incorporated in the system that is schematically illustrated in FIG. 2. For instance, as depicted in FIG. 2, the distal electrode or electrode portion **34** can include a plurality of outlet ports **36** through which saline or other irrigation fluid can exit.

[0252] According to some embodiments, a catheter can include a high-resolution-tip electrode design that includes one or more gaps in the circumferential direction (e.g., radially), either in addition to or in lieu of gaps in the longitudinal direction. One embodiment of a system **300** comprising one or more electrodes **310A**, **310B** is illustrated in FIG. 5. As shown, in arrangements where two or more electrodes are included, the electrodes **310A**, **310B** can be longitudinally or axially offset from each other. For example, in some embodiments, the electrodes **310A**, **310B** are located along or near the distal end of a catheter. In some embodiments, the electrodes **310A**, **310B** are located along an exterior portion of a catheter or other medical instrument. However, in other configurations, one or more of the electrodes can be positioned along a different portion of the catheter or other medical instrument (e.g., along at least an interior portion of a catheter), as desired or required.

[0253] With continued reference to FIG. 5, each electrode **310A**, **310B** can comprise two or more sections **320A**,

**322A** and/or **320B**, **320B**. As shown, in some embodiments, the each section **320A**, **322A** and/or **320B**, **320B** can extend half-way around (e.g., 180 degrees) the diameter of the catheter. However, in other embodiments, the circumferential extent of each section can be less than 180 degrees. For example, each section can extend between 0 and 180 degrees (e.g., 15, 30, 45, 60, 75, 90, 105, 120 degrees, degrees between the foregoing, etc.) around the circumference of the catheter along which it is mounted. Thus, in some embodiments, an electrode can include 2, 3, 4, 5, 6 or more circumferential sections, as desired or required.

[0254] Regardless of how the circumferential electrode sections are designed and oriented, electrically insulating gaps **G** can be provided between adjacent sections to facilitate the ability to use the electrode to conduct high-resolution mapping, in accordance with the various embodiments disclosed herein. Further, as illustrated in the embodiment of FIG. 5, two or more (e.g., 3, 4, 5, more than 5, etc.) electrodes **310A**, **310B** having two or more circumferential or radial sections can be included in a particular system **300**, as desired or required.

[0255] In alternative embodiments, the various embodiments of a high-resolution tip design disclosed herein, or variations thereof, can be used with a non-irrigated system or a closed-irrigation system (e.g., one in which saline and/or other fluid is circulated through or within one or more electrodes to selectively remove heat therefrom). Thus, in some arrangements, a catheter can include two or more irrigation tubes or conduits. For example, one tube or other conduit can be used to deliver fluid toward or near the electrodes, while a second tube or other conduit can be used to return the fluid in the reverse direction through the catheter.

[0256] According to some embodiments, a high-resolution tip electrode is designed to balance the current load between the various electrodes or electrode portions. For example, if a treatment system is not carefully configured, the electrical load may be delivered predominantly to one or more of the electrodes or electrode portions of the high-resolution tip system (e.g., the shorter or smaller distal electrode or electrode portion). This can lead to undesirable uneven heating of the electrode, and thus, uneven heating (e.g., ablation) of the adjacent tissue of the subject. Thus, in some embodiments, one or more load balancing configurations can be used to help ensure that the heating along the various electrodes or electrode portions of the system will be generally balanced. As a result, the high-resolution tip design can advantageously function more like a longer, single electrode, as opposed to two or more electrodes that receive an unequal electrical load (and thus, deliver an unequal amount of heat or level of treatment to the subject's targeted tissue).

[0257] One embodiment of a configuration that can be used to balance the electrical current load delivered to each of the electrodes or electrode portions in a high-resolution tip design is schematically illustrated in FIG. 6. As shown, one of the electrodes (e.g., the distal electrode) **30A** can be electrically coupled to an energy delivery module **40** (e.g., a RF generator). As discussed herein, the module **40** can comprise one or more components or features, such as, for example, an energy generation device that is configured to selectively energize and/or otherwise activate the energy members (e.g., RF electrodes), one or more input/output devices or components, a processor (e.g., a processing or

control unit) that is configured to regulate one or more aspects of the treatment system, a memory and/or the like. Further, such a module can be configured to be operated manually or automatically, as desired or required.

[0258] In the embodiment that is schematically depicted in FIG. 6, the distal electrode **30A** is energized using one or more conductors **82** (e.g., wires, cables, etc.). For example, in some arrangements, the exterior of the irrigation tube **38** comprises and/or is otherwise coated with one or more electrically conductive materials (e.g., copper, other metal, etc.). Thus, as shown in FIG. 6, the conductor **82** can be placed in contact with such a conductive surface or portion of the tube **38** to electrically couple the electrode or electrode portion **30A** to an energy delivery module. However, one or more other devices and/or methods of placing the electrode or electrode portion **30A** in electrical communication with an energy delivery module can be used. For example, one or more wires, cables and/or other conductors can directly or indirectly couple to the electrodes, without the use of the irrigation tube.

[0259] With continued reference to FIG. 6, the first or distal electrode or electrode portion **30A** can be electrically coupled to the second or proximal electrode or electrode portion **30B** using one more band-pass filtering elements **84**, such as a capacitor, a filter circuit (see, e.g., FIG. 16), etc. For instance, in some embodiments, the band-pass filtering element **84** comprises a capacitor that electrically couples the two electrodes or electrode portions **30A**, **30B** when radiofrequency current is applied to the system. In one embodiment, the capacitor **84** comprises a 100 nF capacitor that introduces a series impedance lower than about 3Ω at 500 kHz, which, according to some arrangements, is a target frequency for RF ablation. However, in other embodiments, the capacitance of the capacitor(s) or other band-pass filtering elements **84** that are incorporated into the system can be greater or less than 100 nF, for example, 5 nF to 300 nF, according to the operating RF frequency, as desired or required. In some embodiments, the capacitance of the filtering element **84** is selected based on a target impedance at a particular frequency or frequency range. For example, in some embodiments, the system can be operated at a frequency of 200 kHz to 10 MHz (e.g., 200-300, 300-400, 400-500, 500-600, 600-700, 700-800, 800-900, 900-1000 kHz, up to 10 MHz or higher frequencies between the foregoing ranges, etc.). Thus, the capacitor that couples adjacent electrodes or electrode portions to each other can be selected based on the target impedance for a particular frequency. For example, a 100 nF capacitor provides about 3Ω of coupling impedance at an operating ablation frequency of 500 kHz.

[0260] In some embodiments, a series impedance of 3Ω across the electrodes or electrode portions **30A**, **30B** is sufficiently low when compared to the impedance of the conductor **82** (e.g., wire, cable, etc.), which can be about 5-10Ω, and the impedance of tissue, which can be about 100Ω, such that the resulting tissue heating profile is not negatively impacted when the system is in use. Thus, in some embodiments, a filtering element is selected so that the series impedance across the electrodes or electrode portions is lower than the impedance of the conductor that supplies RF energy to the electrodes. For example, in some embodiments, the insertion impedance of the filtering element is 50% of the conductor **82** impedance, or lower, or 10% of the equivalent tissue impedance, or lower.

[0261] In some embodiments, a filtering element (e.g., capacitor or filter circuit such as the one described herein with reference to FIG. 16, etc.) can be located at a variety of locations of the device or accompanying system. For example, in some embodiments, the filtering element is located on or within a catheter (e.g., near the distal end of the catheter, adjacent the electrode, etc.). In other embodiments, however, the filtering element is separate of the catheter. For instance, the filtering element can be positioned within or along a handle to which the catheter is secured, within the generator or other energy delivery module, within a separate processor or other computing device or component and/or the like).

[0262] Similarly, with reference to the schematic of FIG. 7, a filtering element 384 can be included in an electrode 310 comprising circumferentially-arranged portions 320, 322. In FIG. 7, the filtering element 384 permits the entire electrode 310 to be energized within RF frequency range (e.g., when the electrode is activated to ablate). One or more RF wires or other conductors 344 can be used to deliver power to the electrode from a generator or source. In addition, separate conductors 340 can be used to electrically couple the electrode 310 for mapping purposes.

[0263] In embodiments where the high-resolution-tip design (e.g., FIG. 4) comprises three or more electrodes or electrode portions, additional filtering elements (e.g., capacitors) can be used to electrically couple the electrodes or electrode portions to each other. Such capacitors or other filtering elements can be selected to create a generally uniform heating profile along the entire length of the high-resolution tip electrode. As noted in greater detail herein, for any of the embodiments disclosed herein or variations thereof, the filtering element can include something other than a capacitor. For example, in some arrangements, the filtering element comprises a LC circuit (e.g., a resonant circuit, a tank circuit, a tuned circuit, etc.). Such embodiments can be configured to permit simultaneous application of RF energy and measurement of EGM recordings.

[0264] As discussed above, the relatively small gap G between the adjacent electrodes or electrode portions 30A, 30B can be used to facilitate high-resolution mapping of the targeted tissue. For example, with continued reference to the schematic of FIG. 6, the separate electrodes or electrode portions 30A, 30B can be used to generate an electrogram that accurately reflects the localized electrical potential of the tissue being treated. Thus, a physician or other practitioner using the treatment system can more accurately detect the impact of the energy delivery to the targeted tissue before, during and/or after a procedure. For example, the more accurate electrogram data that result from such configurations can enable the physician to detect any gaps or portions of the targeted anatomical region that was not properly ablated or otherwise treated. Specifically, the use of a high-resolution tip design can enable a cardiac electrophysiologist to more accurately evaluate the morphology of resulting electrograms, their amplitude and width and/or to determine pacing thresholds. In some embodiments, morphology, amplitude and pacing threshold are accepted and reliable EP markers that provide useful information about the outcome of an ablation or other heat treatment procedure.

[0265] According to some arrangements, the high-resolution-tip electrode embodiments disclosed herein are configured to provide localized high-resolution electrogram. For

example, the electrogram that is obtained using a high-resolution-tip electrode, in accordance with embodiments disclosed herein, can provide electrogram data (e.g., graphical output) 400a, 400b as illustrated in FIG. 8. As depicted in FIG. 8, the localized electrograms 400a, 400b generated using the high-resolution-tip electrode embodiments disclosed herein include an amplitude A1, A2.

[0266] With continued reference to FIG. 8, the amplitude of the electrograms 400a, 400b obtained using high-resolution-tip electrode systems can be used to determine whether targeted tissue adjacent the high-resolution-tip electrode has been adequately ablated or otherwise treated. For example, according to some embodiments, the amplitude A1 of an electrogram 400a in untreated tissue (e.g., tissue that has not been ablated or otherwise heated) is greater than the amplitude A2 of an electrogram 400b that has already been ablated or otherwise treated. In some embodiments, therefore, the amplitude of the electrogram can be measured to determine whether tissue has been treated. For example, the electrogram amplitude A1 of untreated tissue in a subject can be recorded and used as a baseline. Future electrogram amplitude measurements can be obtained and compared against such a baseline amplitude in an effort to determine whether tissue has been ablated or otherwise treated to an adequate or desired degree.

[0267] In some embodiments, a comparison is made between such a baseline amplitude (A1) relative to an electrogram amplitude (A2) at a tissue location being tested or evaluated. A ratio of A1 to A2 can be used to provide a quantitative measure for assessing the likelihood that ablation has been completed. In some arrangements, if the ratio (i.e., A1/A2) is above a certain minimum threshold, then the user can be informed that the tissue where the A2 amplitude was obtained has been properly ablated. For example, in some embodiments, adequate ablation or treatment can be confirmed when the A1/A2 ratio is greater than 1.5 (e.g., 1.5-1.6, 1.6-1.7, 1.7-1.8, 1.8-1.9, 1.9-2.0, 2.0-2.5, 2.5-3.0, values between the foregoing, greater than 3, etc.). However, in other embodiments, confirmation of ablation can be obtained when the ratio of A1/A2 is less than 1.5 (e.g., 1-1.1, 1.1-1.2, 1.2-1.3, 1.3-1.4, 1.4-1.5, values between the foregoing, etc.).

[0268] For any of the embodiments disclosed herein, a catheter or other minimally-invasive medical instrument can be delivered to the target anatomical location of a subject (e.g., atrium, pulmonary veins, other cardiac location, renal artery, other vessel or lumen, etc.) using one or more imaging technologies. Accordingly, any of the ablation systems disclosed herein can be configured to be used with (e.g., separately from or at least partially integrated with) an imaging device or system, such as, for example, fluoroscopy technologies, intracardiac echocardiography (ICE) technologies and/or the like.

#### Thermal Shunting

[0269] FIG. 9 illustrates one embodiment of a system 1100 comprising an electrode 1130 (e.g., a unitary RF electrode, a split-tip electrode having two, three or more portions, other types of electrodes, etc.) located at or near the distal end of a catheter 1120. In addition, as with any other embodiments disclosed herein, the system can further include a plurality of ring electrodes 1170 to assist with the execution of a treatment procedure (e.g., mapping of tissue adjacent the treatment site, monitoring of the subject, etc.). Although the

embodiments of the various systems and related methods disclosed herein are described in the context of radiofrequency (RF) based ablation, the heat transfer concepts (including heat shunting embodiments), either alone or in conjunction with other embodiments described herein (e.g., split-tip concepts, temperature sensing concepts, etc.), can be implemented in other types of ablation systems as well, such as those, for example, that use microwave emitters, ultrasound transducers, cryoablation members and/or the like to target tissue of a subject.

[0270] With reference to FIG. 9 and the corresponding partially-exposed view of the distal end of the catheter illustrated in FIG. 10, one or more heat transfer members or other heat transfer components or features, including any of the heat shunting embodiments disclosed herein, can be used to facilitate the heat transfer from or near the electrode to the irrigation conduit 1108 that extends through the interior of the catheter 1120. For example, in some embodiments, as depicted in FIG. 10, one or more heat transfer disks or members 1140 (e.g., heat shunt disks or members) can be positioned along the length of the electrode 1130. In some arrangements, the disks or other heat transfer members 1140 (including any of the heat shunting embodiments disclosed herein) comprise separate components that may or may not contact each other. In other embodiments, however, the heat transfer disks or other heat transfer members 1140 comprise a unitary or monolithic structure, as desired or required. The disks 1140 can be in direct or indirect thermal communication with the irrigation conduit 1108 that passes, at least partially, through an interior portion (e.g., along the longitudinal centerline) of the catheter. For example, the disks 1140 can extend to and make contact with an exterior surface of the irrigation conduit and/or another interior portion of the catheter (e.g., non-irrigation component or portion for embodiments that do not include active cooling using open or closed irrigation). However, in other embodiments, as illustrated in FIG. 11, the disks 1140 can be in thermal communication (e.g., directly via contact or indirectly) with one or more other heat exchange components or members, including any heat shunting components or members, located between the disks and the irrigation conduit.

[0271] A heat sink includes both (i) a heat retention transfer in which heat is localized to/retained by a certain component, and (ii) a heat shunt (which can also be called a heat transfer member) that is used to shunt or transfer heat from, e.g., an electrode to an irrigation passageway. In one embodiment, a heat retention sink is used to retain heat for some period of time. Preferably, a heat shunt (heat transfer member) is used rather than a heat retention sink. A heat shunt (heat transfer member), in some embodiments, provides more efficient dissipation of heat and improved cooling, thus, for example, offering a protective effect to tissue that is considered non-target tissue. For any of the embodiments disclosed herein, one or more heat shunting components can be used to effectively and safely transfer heat away from an electrode and/or the tissue being heated. In some embodiments, a device or system can be configured to adequately transfer heat away from the electrode without any additional components or features (e.g., solely using the heat shunting configurations disclosed herein).

[0272] In any of the embodiments disclosed herein, the ablation system can include one or more irrigation conduits that extend at least partially along (e.g., through an interior portion of) a catheter or other medical instrument configured

for placement within a subject. The irrigation conduit(s) can be part of an open irrigation system, in which fluid exits through one or more exit ports or openings along the distal end of the catheter (e.g., at or near the electrode) to cool the electrode and/or the adjacent targeted tissue. Alternatively, however, the irrigation conduit(s) can be part of a closed irrigation system, in which irrigation fluid is circulated at least partially through (e.g., as opposed to being expelled from) the catheter (e.g., in the vicinity of the electrode or other ablation member to selectively cool the electrode and/or the adjacent tissue of the subject. For example, in some arrangements, the catheter comprises at least two internal fluid conduits (e.g., a delivery conduit and a return conduit) to circulate irrigation fluid to and perform the desired or necessary heat transfer with the distal end of the catheter, as desired or required. Further, in some embodiments, in order to facilitate the heat transfer between the heat transfer members or components included in the ablation system (e.g., heat shunting members or components), the system can comprise an irrigation conduit that comprises one or more metallic and/or other favorable heat transfer materials (e.g., copper, stainless steel, other metals or alloys, ceramics, polymeric and/or other materials with relatively favorable heat transfer properties, etc.). In yet other embodiments, the catheter or other medical instrument of the ablation system does not include any active fluid cooling system (e.g., open or closed irrigation passage or other components extending through it), as desired or required. As discussed in greater detail herein, such embodiments that do not include active cooling using fluid passage through the catheter can take advantage of enhanced heat transfer components and/or designs to advantageously dissipate and/or distribute heat away from the electrode(s) and/or the tissue being treated.

[0273] In some embodiments, the irrigation conduit is fluid communication only with exit ports located along the distal end of the elongate body. In some embodiments, the catheter only comprises irrigation exit openings along a distal end of the catheter (e.g., along a distal end or the electrode). In some embodiments, the system does not comprise any irrigation openings along the heat transfer members (e.g., heat shunt members), and/or, as discussed herein, the system does not comprise an active irrigation system at all. Thus, in such embodiments, the use of heat transfer members along the catheter (e.g., at or near the electrode or other ablation member) help more evenly distribute the heat generated by the electrode or other ablation member and/or assist in heat transfer with the surrounding environment (e.g., blood or other fluid passing along an exterior of the ablation member and/or catheter).

[0274] With continued reference to FIG. 10, the proximal end 1132 of the electrode 1130 comprises one or more additional heat transfer members 1150, including any heat shunt embodiments disclosed herein. For example, according to some embodiments, such additional heat transfer members 1150 (e.g., heat shunt members) comprise one or more fins, pins and/or other members that are in thermal communication with the irrigation conduit 108 extending through an interior of the catheter of the system. Accordingly, as with the heat transfer disks or other heat transfer members 1140 positioned along the length of the electrode 1130, including heat shunting members, heat can be transferred and thus removed, from the electrode, the adjacent

portions of the catheter and/or the adjacent tissue of the subject, when the electrode is activated, via these heat transfer members **1150**.

[0275] In any of the embodiments disclosed herein or variations thereof, the heat transfer members **1140**, **1150** of the system **1100** that are placed in thermal communication with the irrigation conduit **1108** can comprise one or more materials that include favorable heat transfer properties, including, but not limited to, favorable heat shunting properties. For example, in some embodiments, the thermal conductivity of the material(s) included in the heat transfer members and/or of the overall heat transfer assembly (e.g., when viewed as a unitary member or structure) is greater than  $300 \text{ W/m}^\circ \text{ C}$ . (e.g., 300-350, 350-400, 400-450, 450-500, 500-600, 600-700  $\text{W/m}^\circ \text{ C}$ ., ranges between the foregoing, greater than  $700 \text{ W/m}^\circ \text{ C}$ ., etc. Possible materials with favorable thermal conductivity properties include, but are not limited to, copper, brass, beryllium, other metals and/or alloys, alumina ceramics, other ceramics, industrial diamond and/or other metallic and/or non-metallic materials.

[0276] According to certain embodiments where the heat transfer members comprise heat shunting members, the thermal diffusivity of the material(s) included in the heat shunt members and/or of the overall heat shunt assembly (e.g., when viewed as a unitary member or structure) is greater than  $1.5 \text{ cm}^2/\text{sec}$  (e.g., 1.5-2, 2-2.5, 2.5-3, 3-4, 4-5, 5-6, 6-7, 7-8, 8-9, 9-10, 10-11, 11-12, 12-13, 13-14, 14-15, 15-20  $\text{cm}^2/\text{sec}$ , values between the foregoing ranges, greater than  $20 \text{ cm}^2/\text{sec}$ ). Thermal diffusivity measures the ability of a material to conduct thermal energy relative to its ability to store thermal energy. Thus, even though a material can be efficient at transferring heat (e.g., can have a relatively high thermal conductivity), it may not have favorable thermal diffusivity properties, because of its heat storage properties. Heat shunting, unlike heat transferring, requires the use of materials that possess high thermal conductance properties (e.g., to quickly transfer heat through a mass or volume) and a low heat capacity (e.g., to not store heat). Possible materials with favorable thermal diffusivity, and thus favorable heat shunting properties, include, but are not limited to, industrial diamond, Graphene, silica, other carbon-based materials and/or the like.

[0277] The use of materials with favorable thermal diffusivity properties can help ensure that heat can be efficiently transferred away from the electrode and/or the adjacent tissue during a treatment procedure. In contrast, materials that have favorable thermal conductivity properties, but not favorable thermal diffusivity properties, such as, e.g., copper, other metals or alloys, thermally conductive polypropylene or other polymers, etc., will tend to retain heat. As a result, the use of such materials that store heat may cause the temperature along the electrode and/or the tissue being treated to be maintained at an undesirably elevated level (e.g., over  $75 \text{ degrees C}$ .) especially over the course of a relatively long ablation procedure, which may result in charring, thrombus formation and/or other heat-related problems.

[0278] Industrial diamond and other materials with the requisite thermal diffusivity properties for use in a thermal shunting network, as disclosed in the various embodiments herein, comprise favorable thermal conduction characteristics. Such favorable thermal conduction aspects emanate from a relatively high thermal conductance value ( $k$ ) and the

manner in which the heat shunt members of a network are arranged with respect to each other within the tip and with respect to the tissue. For example, in some embodiments, as RF energy is emitted from the tip and the ohmic heating within the tissue generates heat, the exposed distal most shunt member (e.g., located  $0.5 \text{ mm}$  from the distal most end of the tip) can actively extract heat from the lesion site. The thermal energy can advantageously transfer through the shunting network in a relatively rapid manner and dissipate through the shunt residing beneath the RF electrode surface the heat shunt network, through a proximal shunt member and/or into the ambient surroundings. Heat that is shunting through an interior shunt member can be quickly transferred to an irrigation conduit extending through an interior of the catheter or other medical instrument. In other embodiments, heat generated by an ablation procedure can be shunted through both proximal and distal shunt members (e.g., shunt members that are exposed to an exterior of the catheter or other medical instrument, such as shown in many of the embodiments herein).

[0279] Further, as noted above, the materials with favorable thermal diffusivity properties for use in a heat shunt network not only have the requisite thermal conductivity properties but also have sufficiently low heat capacity values ( $c$ ). This helps ensure that the thermal energy is dissipated very quickly from the tip to tissue interface as well as the hot spots on the electrode, without heat retention in the heat shunting network. The thermal conduction constitutes the primary heat dissipation mechanism that ensures quick and efficient cooling of the tissue surface and of the RF electrode surface. Conversely a heat transfer (e.g., with relatively high thermal conductivity characteristics but also relatively high heat capacity characteristics) will store thermal energy. Over the course of a long ablation procedure, such stored heat may exceed  $75 \text{ degrees C}$ . Under such circumstances, thrombus and/or char formation can undesirably occur.

[0280] The thermal convection aspects of the various embodiments disclosed herein two-fold. First, an irrigation lumen of the catheter can absorb thermal energy which is transferred to it through the shunt network. Such thermal energy can then be flushed out of the distal end of the RF tip via the irrigation ports. In closed irrigation systems, however, such thermal energy can be transferred back to a proximal end of the catheter where it can be removed. Second, the exposed shunt surfaces along an exterior of the catheter or other medical instrument can further assist with the dissipation of heat from the electrode and/or the tissue being treated. For example, such heat dissipation can be accomplished via the inherent convective cooling aspects of the blood flowing over the surfaces of the electrode.

[0281] Accordingly, the use of materials in a heat shunting network with favorable thermal diffusivity properties, such as industrial diamond, can help ensure that heat is quickly and efficiently transferred away from the electrode and treated tissue, while maintaining the heat shunting network cool (e.g., due to its low heat capacity properties). This can create a safer ablation catheter and related treatment method, as potentially dangerous heat will not be introduced into the procedure via the heat shunting network itself.

[0282] For example, in some embodiments, during the course of an ablation procedure that attempts to maintain the subject's tissue at a desired temperature of about  $60 \text{ degrees C}$ ., the temperature of the electrode is approximately  $60 \text{ degrees Celsius}$ . Further, the temperature of traditional heat

transferring members positioned adjacent the electrode (e.g., copper, other metals or alloys, thermally-conductive polymers, etc.) during the procedure is approximately 70 to 75 degrees Celsius. In contrast, the temperature of the various portions or members of the heat shunting network for systems disclosed herein can be approximately 60 to 62 degrees Celsius (e.g., 10% to 30% less than comparable heat transferring systems) for the same desired level of treatment of tissue.

**[0283]** In some embodiments, the heat shunt members disclosed herein draw out heat from the tissue being ablated and shunt it into the irrigation channel. Similarly, heat is drawn away from the potential hot spots that form at the edges of RF electrodes and are shunted through the heat shunt network into the irrigation channel. From the irrigation channel, via convective cooling, heat can be advantageously released into the blood stream and dissipated away. In closed irrigation systems, heat can be removed from the system without expelling irrigation fluid into the subject.

**[0284]** According to some embodiments, the various heat shunting systems disclosed herein rely on heat conduction as the primary cooling mechanism. Therefore, such embodiments do not require a vast majority of the heat shunting network to extend to an external surface of the catheter or other medical instrument (e.g., for direct exposure to blood flow). In fact, in some embodiments, the entire shunt network can reside within an interior of the catheter tip (i.e., with no portion of the heat shut network extending to an exterior of the catheter or other medical instrument). Further, the various embodiments disclosed herein do not require electrical isolation of the heat shunts from the RF electrode or from the irrigation channel.

**[0285]** According to some embodiments, the heat transfer disks and/or other heat transfer members **1140**, **1150** included in a particular system, including heat shunting members or components, can continuously and/or intermittently or partially extend to the irrigation conduit **108**, as desired or required for a particular design or configuration. For instance, as illustrated in the embodiment of FIG. **10**, the proximal heat transfer member **1150** (e.g., heat shunt members) can comprise one or more (e.g., 2, 3, 4, 5, more than 5, etc.) wings or portions **1154** that extend radially outwardly from a base or inner member **1152**. In some embodiments, such wings or radially-extending portion **1154** are equally spaced from each other to more evenly transfer heat toward the irrigation conduit **1108** with which the heat transfer member **1150** is in thermal communication. Alternatively, however, the heat transfer member **1150**, including, but not limited to, a heat shunt member, can include a generally solid or continuous structure between the irrigation conduit **1108** and a radially exterior portion or region of the catheter.

**[0286]** According to some embodiments, heat transfer members (e.g., fins) **1150** can extend proximally to the proximal end of the electrode(s) included along the distal end of a catheter. For example, as illustrated in FIG. **10**, the heat transfer members **1150** (e.g., heat shunt members) can extend to, near or beyond the proximal end of the electrode **1130**. In some embodiments, the heat transfer members **1150** terminate at or near the proximal end **1132** of the electrode **1130**. However, in other arrangements, the heat transfer members **1150**, including, without limitation, heat shunt members, extend beyond the proximal end **1132** of the electrode **1130**, and in some embodiments, contact and/or

are otherwise in direct or indirect thermal communication with distally-located heat transfer members (e.g., heat transfer disks or other heat transfer members located along or near the length of the electrode **1130**), including heat shunt members, as desired or required. In yet other embodiments, proximal heat transfer members (e.g., heat shunt members) terminate proximally to the proximal end **1132** of the electrode or other ablation member.

**[0287]** In any of the embodiments disclosed herein, including the systems comprising the enhanced heat transfer (e.g., heat shunting) properties discussed in connection with FIGS. **9-12**, the system can include one or more temperature sensors or temperature detection components (e.g., thermocouples) for the detection of tissue temperature at a depth. For example, in the embodiments illustrated in FIGS. **9** and **10**, the electrode and/or other portion of the distal end of the catheter can include one or more sensors (e.g., thermocouples, thermistors, etc.) and/or the like. Thus, signals received by sensors and/or other temperature-measurement components can be advantageously used to determine or approximate the extent to which the targeted tissue is being treated (e.g., heated, cooled, etc.). Temperature measurements can be used to control an ablation procedure (e.g., module power provided to the ablation member, terminate an ablation procedure, etc.), in accordance with a desired or required protocol.

**[0288]** In some embodiments, the device further comprises a one or more temperature sensors or other temperature-measuring devices to help determine a peak (e.g., high or peak, low or trough, etc.) temperature of tissue being treated. In some embodiments, the temperature sensors (e.g., thermocouples) located at, along and/or near the ablation member (e.g., RF electrode) can help with the determination of whether contact is being made between the ablation member and targeted tissue (and/or to what degree such contact is being made). In some embodiments, such peak temperature is determined without the use of radiometry. Additional details regarding the use of temperature sensors (e.g., thermocouples) to determine peak tissue temperature and/or to confirm or evaluate tissue contact are provided herein.

**[0289]** In some embodiments, for any of the systems disclosed herein (including but not limited to those illustrated herein) or variations thereof, one or more of the heat transfer members, including, but not limited to, heat shunt members, that facilitate the heat transfer to an irrigation conduit of the catheter are in direct contact with the electrode and/or the irrigation conduit. However, in other embodiments, one or more of the heat transfer members (e.g., heat shunt members) do not contact the electrode and/or the irrigation conduit. Thus, in such embodiments, the heat transfer members are in thermal communication with the electrode and/or irrigation conduit, but not in physical contact with such components. For example, in some embodiments, one or more intermediate components, layers, coatings and/or other members are positioned between a heat transfer member (e.g., a heat shunt member) and the electrode (or other ablation member) and/or the irrigation conduit.

**[0290]** FIG. **11** illustrates another embodiment of an ablation system **1200** comprising an electrode (e.g., a RF electrode, a split-tip electrode, etc.) or other ablation member **1230** located along or near the distal end of a catheter or other elongated member. In some embodiments, an interior

portion **1236** of the electrode or other ablation member (not shown in FIG. **11**, for clarity) can include a separate, internal heat transfer member **1250B**, including any heat shunt embodiments disclosed herein. Such a heat transfer member **1250B** can be in addition to or in lieu of any other heat transfer members located at, within and/or near the electrode or other ablation member. For example, in the depicted embodiment, in the vicinity of the electrode **1230**, the system **1200** comprises both an internal heat transfer member **1250B** and one or more disk-shaped or cylindrical heat transfer members **1240** (e.g., heat shunting members).

[**0291**] For any of the embodiments disclosed herein, at least a portion of heat transfer member, including a heat shunt member, that is in thermal communication with the irrigation conduit extends to an exterior surface of the catheter, adjacent to (and, in some embodiments, in physical and/or thermal contact with) the electrode or other ablation member. Such a configuration, can further enhance the cooling of the electrode or other ablation member when the system is activated, especially at or near the proximal end of the electrode or ablation member, where heat may otherwise tend to be more concentrated (e.g., relative to other portions of the electrode or other ablation member). According to some embodiments, thermal conductive grease and/or any other thermally conductive material (e.g., thermally-conductive liquid or other fluid, layer, member, coating and/or portion) can be used to place the thermal transfer, such as, for example, a heat shunt member or heat shunt network, in thermal communication with the irrigation conduit, as desired or required. In such embodiments, such a thermally conductive material places the electrode in thermal communication, at least partially, with the irrigation conduit.

[**0292**] With continued reference to FIG. **11**, the heat transfer member (e.g., heat shunt member) **1250B** located along an interior portion of the electrode **1230** can include one or more fins, wings, pins and/or other extension members **1254B**. Such members **1254B** can help enhance heat transfer with the (e.g., heat shunting to, for heat shunting embodiments) irrigation conduit **1208**, can help reduce the overall size of the heat transfer member **1254B** and/or provide one or more additional advantages or benefits to the system **1200**.

[**0293**] Another embodiment of an ablation system **1300** comprising one or more heat transfer (e.g., heat shunt) components or features that facilitate the overall heat transfer of the electrode or other ablation member during use is illustrated in FIG. **12**. As shown, heat transfer (e.g., shunting) between one or more heat transfer members **1350B** located along an interior of an electrode or other ablation member **1330** can be facilitated and otherwise enhanced by eliminating air gaps or other similar spaces between the electrode and the heat transfer members. For example, in the illustrated embodiment, one or more layers **1356** of an electrically conductive material (e.g., platinum, gold, other metals or alloys, etc.) have been positioned between the interior of the electrode **1330** and the exterior of the heat transfer member **1350B**. Such layer(s) **1356** can be continuously or intermittently applied between the electrode (or another type of ablation member or energy delivery member) and the adjacent heat transfer member(s), including, but not limited to, heat shunting member(s). Further, such layer(s) **1356** can be applied using one or more methods or procedures, such as, for example, sputtering, other plating

techniques and/or the like. Such layer(s) **1356** can be used in any of the embodiments disclosed herein or variations thereof.

[**0294**] FIG. **13** illustrates a distal portion of a catheter or other medical instrument of an ablation system **1800** comprising one or more heat transfer members **1850** (e.g., heat shunt members) that facilitate the efficient transfer of heat generated by the electrode or other energy delivery member **1830**. As shown in FIG. **13**, the heat shunt members **1850** are positioned immediately adjacent (e.g., within an interior of) the electrode **1830**. Accordingly, as discussed in greater detail herein, heat generated by the electrode or other energy delivery member **1830** can be transferred via the one or more heat shunt members **1850**. As discussed above, the heat shunt members advantageously comprise favorable thermal diffusivity properties to quickly transfer heat while not retaining heat. Thus, the likelihood of localized hot spots (e.g., along the distal and/or proximal ends of the electrode) can be prevented or reduced. In addition, the heat dissipation or removal (e.g., away from the electrode) can be more easily and/or quickly realized using the heat shunt members **1850**.

[**0295**] As discussed herein, for example, the heat shunt members **1850** can include industrial diamond, Graphene, silica or other carbon-based materials with favorable thermal diffusivity properties and/or the like. In some embodiments, the heat shunt members **1850** comprise a combination of two, three or more materials and/or portions, components or members. In some embodiments, the thermal diffusivity of the material(s) included in the heat shunt members and/or of the overall heat shunting network or assembly (e.g., when viewed as a unitary member or structure) is greater than 1.5 cm<sup>2</sup>/sec (e.g., 1.5-2, 2-2.5, 2.5-3, 3-4, 4-5, 5-6, 6-7, 7-8, 8-9, 9-10, 10-11, 11-12, 12-13, 13-14, 14-15, 15-20 cm<sup>2</sup>/sec, values between the foregoing ranges, greater than 20 cm<sup>2</sup>/sec).

[**0296**] The heat shunt members **1850** (e.g., fins, rings, blocks, etc.) can be in direct or indirect contact with the electrode or other energy delivery member **1830**. Regardless of whether direct physical contact is made between the electrode and one or more of the heat transfer shunt **1850**, the heat shunt members **1850** can be advantageously in thermal communication with the electrode, thereby facilitating the heat dissipation and/or heat transfer properties of the catheter or other medical instrument. In some embodiments, for example, one or more intermediate layers, coatings, members and/or other components are positioned between the electrode (or other energy delivery member) and the heat shunt members, as desired or required.

[**0297**] With continued reference to FIG. **13**, as discussed with other embodiment herein, a catheter or other medical instrument of the ablation system **1800** comprises an open irrigation system configured to deliver a cooling fluid (e.g., saline) to and through the distal end of the catheter or other medical instrument. Such an open irrigation system can help remove heat from the electrode or other energy delivery member during use. In some embodiments, the heat shunting network and the favorable thermal diffusivity properties it possesses can help to quickly and efficiently transfer heat from the electrode and/or the tissue being treated to an irrigation conduit or passage **1804** or chamber **1820** during use. For example, as depicted in FIG. **13**, an irrigation conduit or passage **1804** extends through an interior of the catheter and is in fluid communication with one or more

outlet ports **1811** along the distal member **1810** of the catheter. However, as discussed in greater detail herein, enhanced heat shunt members can be incorporated into the design of a catheter or other medical instrument without the use of an open irrigation system and/or without an active fluid cooling system, as desired or required. In some embodiments, the flow of irrigation fluid (e.g., saline) through the irrigation conduit or chamber of the catheter or other medical instrument can be modified to vary the heat shunting that occurs through the heat shunting network. For example, in some embodiments, due to the favorable heat transfer properties of the heat shunting network and its ability to not retain heat, the flow rate of irrigation fluid through a catheter can be maintained below 5 ml/min (e.g., 1-2, 2-3, 3-4, 4-5 ml/min, flow rates between the foregoing ranges, less than 1 ml/min, etc.). In one embodiment, the flow rate of irrigation fluid through a catheter is maintained at approximately 1 ml/min. In other embodiments, the flow rate of irrigation fluid passing through the catheter can be between 5 and 15 ml/min (e.g., 5-6, 6-7, 7-8, 8-9, 9-10, 11-12, 12-13, 13-14, 14-15 ml/min, flow rates between the foregoing rates, etc.) or greater than 15 ml/min (e.g., 15-16, 16-17, 17-18, 18-19, 19-20 ml/min, flow rates between the foregoing rates, etc.), as desired or required. In some embodiments, such irrigation flow rates are significantly less than would otherwise be required if non-heat shunting members (e.g., metals, alloys, thermally-conductive polymers, other traditional heat transferring members, etc.) were being used to transfer heat away from the electrode and/or the tissue between treated. For example, the required flow rate of the irrigation fluid passing through an interior of a catheter that has a heat shunting member in accordance with the various embodiments disclosed herein or variations thereof, can be decreased by 20% to 90% (e.g., 20-25, 25-30, 30-35, 35-40, 40-45, 45-50, 50-55, 55-60, 60-65, 65-70, 70-75, 75-80, 80-85, 85-90%, percentages between the foregoing ranges, etc.), as compared to systems that use traditional heat transferring members or no heat transferring members at all (e.g., assuming the same amount of heating is produced at the electrode, the same anatomical location is being treated and other parameters are the same). For example, in some commercially available RF ablation systems, an irrigation flow rate of about 30 ml/min (e.g., 25-35 ml/min) is typically required to accomplish a desired level of heat transfer way from the electrode. As noted above, in some arrangements, the systems disclosed herein that utilize a heat shunting network can utilize a irrigation flow rate of about 10 ml/min or lower to effectively shunt the heat away from the electrode. Thus, in such embodiments, the irrigation flow rate can be reduced by at least 60% to 70% relative to traditional and other commercially available systems.

**[0298]** Thus, as noted in greater detail herein, the use of heat shunting materials to shunt heat away from the electrode and/or the adjacent tissue can also reduce the amount of irrigation fluid that is being discharged into the subject's blood stream in an open irrigation system. Since the discharge of irrigation fluid into the subject is not desirable, the use of heat shunting in an ablation catheter can provide additional benefits to an ablation procedure. For example, in some arrangements, discharging excessive saline or other cooling fluid into the heart, blood vessel and/or other targeted region of the subject can bring about negative physiological consequences to the subject (e.g., heart failure).

**[0299]** As noted above, the use of heat shunting components at or near the electrode can also provide one or more additional benefits and advantages. For example, a significantly lower irrigation flow rate is required to effectively remove heat away from the electrode and the surrounding tissue using heat shunting components (e.g., vis-à-vis traditional heat transferring components and members), the irrigation fluid in such systems is less likely to negatively impact any temperature sensors that are located along or near the outside of the distal end of a catheter, allowing more accurate temperature measurements. This is particularly relevant for systems, such as those disclosed herein, where temperature sensors are configured to detect the temperature of adjacent tissue of a subject (e.g., not the temperature of the electrode or another component or portion of the treatment system). Thus, the lower volume of fluid being discharged at or in the vicinity of the sensors (e.g., compared to systems that do not use heat shunting, systems that include traditional heat transfer components, systems that rely primarily or strictly on heat transfer between the electrode (and/or tissue) and blood passing adjacent the electrode (and/or tissue), other open-irrigation systems, etc.) can increase the accuracy of the temperature measurements obtained by the sensors located at or near the distal end of a catheter or other medical instrument.

**[0300]** Also, since the irrigation fluid can be delivered at a lower flow rate which is characterized by a laminar flow profile (e.g., as opposed to a turbulent flow profile that may be required when the irrigation flow rate is higher), any disruptive fluid dynamic effects resulting from an otherwise higher flow rate can be advantageously avoided or at least reduced. Thus, the laminar flow of fluid (and/or in conjunction with the significantly lower flow rate of the fluid relative to higher flow systems) can help with the accuracy of the temperature measurements by the sensors located near the electrode, the tissue being treated and/or any other location along the distal end of the catheter or other medical instrument.

**[0301]** Further, since heat shunting components positioned along or near the electrode are so effective in transferring heat away from the electrode and/or the adjacent tissue of the subject being treated without retaining the heat being transferred, the need to have a longer electrode and/or larger heat transferring members or portions can be advantageously eliminated. For example, traditional systems that utilize one or more heat transferring members (as opposed and in contrast to heat shunting members) or systems that do not use any heat transferring members or components at all rely on the heat transfer between the electrode and the surrounding environment (e.g., blood that flows past the electrode, irrigation fluid passing through an interior of the catheter, etc.) to attempt to cool the electrode. As a result, the length, size and/or other dimensions of the electrode or traditional heat transferring members needs to be increased. This is done to increase the surface area for improved heat transfer between the electrode and/or the heat transferring members and the fluid that will provide the heat transfer (e.g., blood, irrigation fluid, etc.). However, in various embodiments disclosed herein, it is advantageously not necessary to provide such enlarged surface areas for the electrode and/or the heat shunting components or other members of the heat shunting network. Accordingly, the electrode can be sized based on the intended ablation/heating and/or mapping (e.g., high-resolution) properties

without the need to oversize based on heat transfer capacity. Such oversizing can negatively impact the safety and efficacy of a lesion formation procedure.

[0302] Therefore, as discussed herein, in some embodiments, the size of the heat shunting members can be advantageously reduced (e.g., as compared to the size of heat transferring members in traditional systems). Heat generated during a treatment procedure can be efficiently and rapidly transferred away from electrode and/or the tissue being treated via the heat shunting network without the fear of such network retaining the heat being transferred. In some embodiments, the heat can be shunted to irrigation fluid passing through an interior of the catheter or other medical instrument. In other embodiments, heat can be transferred to surrounding bodily fluid of the subject (e.g., blood) via heat shunting members that are positioned along an exterior of the catheter or other medical instrument, either in addition or in lieu of heat shunting to an irrigation fluid.

[0303] According to some embodiments, the total length (e.g., along a longitudinal direction) of the heat shunting members that extend to the exterior of the catheter or other medical instrument (such as, e.g., in the configurations depicted in FIGS. 13 to 17B) can be 1 to 3 mm (e.g., 1-1.5, 1.5-2, 2-2.5, 2.5-3 mm, lengths between the foregoing values, etc.). As noted above, despite such a relatively short exposure length, the heat shunting members can effectively transfer heat away from the electrode and/or the tissue being ablated without retaining heat.

[0304] According to some embodiments, the total length (e.g., along a longitudinal direction) of the heat shunting members that extend along an interior of the catheter or other medical instrument (such as, e.g., in the configurations depicted in FIGS. 13 to 17B) can be 1 to 30 mm (e.g., 1-2, 2-3, 3-4, 4-5, 5-6, 6-7, 7-8, 8-9, 9-10, 10-11, 11-12, 12-13, 13-14, 14-15, 15-20, 20-25, 25-30 mm, lengths between the foregoing values, etc.). As noted above, despite such a relatively short overall length, the heat shunting members can effectively transfer heat away from the electrode and/or the tissue being ablated to fluid passing through the irrigation channel of the catheter or other medical instrument without retaining heat.

[0305] According to some embodiments, the total length (e.g., along a longitudinal direction) of the heat shunting members that extend along an interior of the catheter or other medical instrument plus the electrode (such as, e.g., in the configurations depicted in FIGS. 13 to 17B) can be 1 to 30 mm (e.g., 1-2, 2-3, 3-4, 4-5, 5-6, 6-7, 7-8, 8-9, 9-10, 10-11, 11-12, 12-13, 13-14, 14-15, 15-20, 20-25, 25-30 mm, lengths between the foregoing values, etc.). As noted above, despite such a relatively short overall length, the heat shunting members can effectively transfer heat away from the electrode and/or the tissue being ablated to fluid passing through the irrigation channel of the catheter or other medical instrument without retaining heat.

[0306] As illustrated in FIG. 13, an interior of the distal end of the catheter or other medical instrument can comprise a cooling chamber or region 1820 that is in fluid communication with the irrigation conduit or passage 1804. As shown, according to some embodiments, the cooling chamber 1820 includes a diameter or cross-sectional dimension that is greater than the diameter or cross-sectional dimension of the fluid conduit or passage 1804. For example, in some arrangements, the diameter or other cross-sectional dimension of the cooling chamber or region 1820 is approximately

1 to 3 times (e.g., 1 to 1.1, 1.1 to 1.2, 1.2 to 1.3, 1.3 to 1.4, 1.4 to 1.5, 1.5 to 1.6, 1.6 to 1.7, 1.7 to 1.8, 1.8 to 1.9, 1.9 to 2.0, 2.0 to 2.1, 2.1 to 2.2, 2.2 to 2.3, 2.3 to 2.4, 2.4 to 2.5, 2.5 to 2.6, 2.6 to 2.7, 2.7 to 2.8, 2.8 to 2.9, 2.9 to 3, values between the foregoing, etc.) the diameter or cross-section dimension of the fluid conduit or passage 1804, as desired or required. In other embodiments, the diameter or other cross-sectional dimension of the cooling chamber or region 1820 is approximately greater than 3 times the diameter or cross-section dimension of the fluid conduit or passage 1804, as desired or required (e.g., 3 to 3.5, 3.5 to 4, 4 to 5, values between the foregoing, greater than 5, etc.). In other embodiments, the diameter or cross-section dimension of the cooling chamber or region 1820 is similar or identical to that of the fluid conduit or passage 1804 (or smaller than that of the fluid conduit or passage), as desired or required.

[0307] FIG. 14 illustrates a distal end of a catheter or other medical instrument of another embodiment of an ablation system 1900. As shown, the catheter comprises one or more energy delivery members 1930 (e.g., a split-tip RF electrode, another type of electrode, another type of ablation member, etc.) along its distal end. Like in FIG. 13, the depicted arrangement comprises an active cooling system using one or more fluid conduits or passages that extend at least partially through the interior of the catheter or other medical instrument.

[0308] With continued reference to FIG. 14, the catheter or medical instrument of the ablation system 1900 includes a closed irrigation system (e.g., non-open irrigation system) in which cooling fluid (e.g., saline) is circulated at least partially through an interior of the catheter (e.g., to and/or near the location of the electrode or other energy delivery member) to transfer heat away from such electrode or other energy delivery member. As shown, the system can include two separate conduits or passages 1904, 1906 extending at least partially through the interior of the catheter or other medical instrument configured for placement within and/or adjacent targeted tissue of a subject. In some embodiments, one fluid conduit or passage 1904 is configured to deliver fluid (e.g., saline) to the distal end of the catheter or instrument (e.g., adjacent the electrode, ablation member or other energy delivery member), while a separate conduit or passage 1906 is configured to return the cooling fluid delivered to or near the distal end of the catheter or other medical instrument proximally. In other embodiments, more than one passage or conduit delivers fluid to the distal end and/or more than one passage or fluid returns fluid from the distal end, as desired or required.

[0309] In the embodiment of FIG. 14, the fluid delivery conduit or passage 1904 is in fluid communication with a cooling chamber or region 1920 that extends within an interior of the electrode or other energy delivery member 1930. In the depicted arrangement, the outlet 1905 of the fluid delivery conduit or passage 1904 is located at a location proximal to the distal end or inlet 1907 of the fluid return conduit or passage 1906. Thus, in the illustrated embodiment, the cooling chamber or region 1920 generally extends between the outlet 1905 of the fluid delivery conduit or passage 1904 and the inlet 1907 of the fluid return conduit or passage 1906. However, in other embodiments, the length, orientation, location and/or other details of the cooling chamber or portion 1920 can vary, as desired or required. Further, in some embodiments, a catheter or other medical instrument can include a closed fluid cooling system

(e.g., wherein cooling fluid is circulated through the catheter or medical instrument) without the inclusion of a separate cooling chamber or portion. Regardless of the exact orientation of the various fluid delivery and/or return lines (e.g., passages, conduits, etc.) of the catheter or medical instrument in a closed-loop fluid cooling system, fluid is simply circulated through at least a portion of the catheter or other medical instrument (e.g., adjacent and/or in the vicinity of the electrode or energy delivery member being energized) to selectively and advantageously transfer heat away from the electrode or energy delivery member. Thus, in such embodiments, the various fluid conduits or passages are in thermal communication with the electrode or other energy delivery member.

**[0310]** In some embodiments, it is advantageous to transfer heat away from the electrode (or other energy delivery member) of an ablation system, and thus, the targeted tissue of the subject, without expelling or discharging cooling fluid (e.g., saline) into the subject. For example, in some arrangements, discharging saline or other cooling fluid into the heart, blood vessel and/or other targeted region of the subject can bring about negative physiological consequences to the subject (e.g., heart failure). Thus, in some embodiments, it is preferred to treat a subject with an ablation system that includes a catheter or other medical instrument with a closed fluid cooling system or without an active fluid cooling system altogether.

**[0311]** As with the embodiment of FIG. 14 (and/or other embodiments disclosed herein), the depicted catheter includes one or more heat shunt members 1950 that are in thermal communication with the electrode, ablation member or other energy delivery member 1930 of the system 1900. As discussed above, the heat shunt members 1950 can include industrial diamond, Graphene, silica, other carbon-based materials with favorable thermal diffusivity properties and/or the like. In some embodiments, the thermal diffusivity of the material(s) included in the heat shunt members and/or of the overall heat shunt network or assembly (e.g., when viewed as a unitary member or structure) is greater than 1.5 cm<sup>2</sup>/sec (e.g., 1.5-2, 2-2.5, 2.5-3, 3-4, 4-5, 5-6, 6-7, 7-8, 8-9, 9-10, 10-11, 11-12, 12-13, 13-14, 14-15, 15-20 cm<sup>2</sup>/sec, values between the foregoing ranges, greater than 20 cm<sup>2</sup>/sec).

**[0312]** FIG. 15 illustrates yet another embodiment of a catheter or other medical instrument of an ablation system 2000 can include one or more heat transfer members 2050 (e.g., heat shunt members) along and/or near its distal end. Unlike the arrangements of FIGS. 13 and 14 discussed herein, the depicted embodiment does not include an active fluid cooling system. In other words, the catheter or other medical instrument does not comprise any fluid conduits or passages. Instead, in some embodiments, as illustrated in FIG. 15, the distal end of the catheter comprises one or more interior members (e.g., interior structural members) 2070 along its interior. Such interior members 2070 can include a member or material having favorable thermal diffusivity characteristics. In some embodiments, the interior member 2070 comprises identical or similar thermal diffusivity characteristics or properties as the heat shunt members 2050, such as, for example, industrial diamond or Graphene. In some embodiments, the thermal diffusivity of the material(s) included in the interior member 2070 and/or of the overall heat shunt network or assembly (e.g., when viewed as a unitary member or structure) is greater than 1.5 cm<sup>2</sup>/sec

(e.g., 1.5-2, 2-2.5, 2.5-3, 3-4, 4-5, 5-6, 6-7, 7-8, 8-9, 9-10, 10-11, 11-12, 12-13, 13-14, 14-15, 15-20 cm<sup>2</sup>/sec, values between the foregoing ranges, greater than 20 cm<sup>2</sup>/sec). However, in other embodiments, the interior member(s) do not include high heat shunting materials and/or members. In other embodiments, however, the interior member 2070 does not include materials or members similar to those as the heat shunt members 2050. For example, in some arrangements, the interior member(s) 2070 can include one or more components or members that comprise material(s) having a thermal diffusivity less than 1 cm<sup>2</sup>/sec.

**[0313]** With continued reference to the embodiment of FIG. 15, the volume along the distal end of the catheter or medical instrument includes a structural member that at least partially occupies said volume. This is in contrast to other embodiments disclosed herein, wherein at least a portion of the distal end of the catheter or medical instrument includes a cavity (e.g., a cooling chamber) that is configured to receive cooling fluid (e.g., saline) when such cooling fluid is delivered and/or circulated through the catheter or medical instrument.

**[0314]** In embodiments such as the one illustrated in FIG. 15, wherein no active fluid cooling is incorporated into the design of the catheter or other medical instrument of the ablation system 2000, heat generated by and/or at the electrode (or other energy delivery member) 2030 can be more evenly dissipated along the distal end of the catheter or medical instrument as a result of the heat dissipation properties of the heat transfer members 2050, including, without limitation, heat shunt members, (and/or the interior member 2070, to the extent that the interior member 2070 also comprises favorable heat shunting properties, e.g., materials having favorable thermal diffusivity characteristics). Thus, the heat shunt members 2050 can help dissipate heat away from the electrode or other energy delivery member (e.g., either via direct or indirect thermal contact with the electrode or other energy delivery member) to reduce the likelihood of any localized hotspots (e.g., along the distal and/or proximal ends of the electrode or other energy delivery member). Accordingly, heat can be more evenly distributed with the assistance of the heat shunt member 2050 along a greater volume, area and/or portion of the catheter. As discussed above, the use of heat shunting members can quickly and efficiently transfer heat away from the electrode and the tissue being treated during use. The use of materials that comprises favorable thermal diffusivity properties can accomplish the relatively rapid heat transfer without the negative effect of heat retention (e.g., which may otherwise cause charring, thrombus formation and/or other heat-related problems).

**[0315]** Further, in some embodiments, the flow of blood or other natural bodily fluids of the subject in which the catheter or medical instrument is positioned can facilitate with the removal of heat away from the electrode or other energy delivery member. For example, the continuous flow of blood adjacent the exterior of the catheter during use can help with the removal of heat away from the distal end of the catheter. Such heat transfer can be further enhanced or otherwise improved by the presence of one or more heat shunt members that are in thermal communication with the exterior of the catheter. For example, in some arrangements, such as shown in FIG. 15, one or more heat shunt members 2050 can extend to the exterior of the catheter or other medical instrument. Thus, as blood (and/or other bodily

fluids) moves past the catheter or other medical instrument when the catheter or medical instrument is inserted within the subject during use, heat can be advantageously transferred through the heat shunt members 2050 to the blood and/or other bodily fluids moving adjacent the catheter. Again, the use of heat shunt materials with favorable thermal diffusivity characteristics will ensure that heat is not retained within such materials, thereby creating a safer ablation system and treatment procedure.

[0316] FIGS. 16A and 16B illustrate another embodiment of a catheter or other medical instrument of an ablation system 2100 that includes one or more heat transfer members 2050 (e.g., heat shunt members) along and/or near its distal end. Unlike other embodiments disclosed herein, the illustrated system includes a proximal electrode or electrode portion 2130 that extends deeper into the interior of the catheter. For example, as depicted in the side cross-sectional view of FIG. 16B, the proximal electrode 2130 can extend to or near the outside of the irrigation channel 2120. As discussed herein, the irrigation channel 2120 can comprise one or more metals, alloys and/or other rigid and/or semi-rigid materials, such as, for example, stainless steel.

[0317] With continued reference to FIGS. 16A and 16B, the proximal electrode or proximal electrode portion 2130 can be part of a split-tip electrode system, in accordance with the various split-tip embodiments disclosed herein. Thus, in some embodiments, in order for the split tip electrode configuration to operate properly, the distal electrode 2110 is electrically isolated from the proximal electrode 2130. In the illustrated configuration, since the proximal electrode 2130 extends to or near the metallic (and thus, electrically conductive) irrigation tube 2120, at least one electrically insulative layer, coating, member, portion, barrier and/or the like 2128 can be advantageously positioned between the electrode 2130 and the irrigation tube 2120. In some embodiments, for example, the electrically insulative member 2128 comprises one or more layers of polyimide, other polymeric material and/or another electrically insulative material, as desired or required. Such an electrically-insulative layer and/or other member 2128 can take the place of diamond and/or another electrically-insulative heat shunting member that may otherwise be positioned around the irrigation tube 2120 to electrically isolate the distal electrode 2110 from the proximal electrode 2130.

[0318] According to any of the embodiments disclosed herein, the proximal and/or the distal electrodes 2130, 2110 can comprise one or more metals and/or alloys. For example, the electrodes can include platinum, stainless steel and/or any other biocompatible metal and/or alloy. Thus, in some embodiments, the thicker proximal electrode 2130 that extends to or near the irrigation tube 2120 can be referred to as a “slug,” e.g., “a platinum slug.” As discussed, in such arrangements, the need for an internal diamond and/or other heat shunting member can be eliminated. Instead, in such embodiments, as depicted in FIG. 16B, the proximal and distal ends of the “slug” or thicker proximal electrode 2130 can be placed in thermal communication with one or more heat shunting members (e.g., diamond) to help shunt heat away from the electrode 2130 and/or the tissue of the subject being treated. Thus, in some embodiments, the proximal and/or the distal faces of the proximal electrode or slug 2130 can be placed in good thermal contact with adjacent heat shunting members, as desired or required.

[0319] With continued reference to FIG. 16B, according to some embodiments, at least a portion 2222 of the irrigation tube 2120 is perforated and/or has one or more openings 2123. In some embodiments, such openings 2123 can place an irrigation fluid carried within the interior of the irrigation channel 2120 in direct physical and thermal communication with an adjacent heat shunting member (e.g., diamond, Graphene, silica, etc.) to quickly and efficiently transfer heat away from the electrode and/or tissue being treated. In some embodiments, the direct physical and/or thermal communication between the irrigation fluid and the shunting member helps provide improved heat transfer to the irrigation fluid (e.g., saline) passing through the interior of the irrigation channel 2120. In the illustrated embodiment, the openings 2123 along the perforated portion 2222 are generally circular in shape and evenly distributed relative to each other (e.g., comprise a generally even distribution or spacing relative to each other). However, in other arrangements, the size, shape, spacing and/or other characteristics of the openings 2123 along the perforated or direct contact region 2122 of the channel 2120 can vary, as desired or required. For example, in some embodiments, the openings 2123 can be oval, polygonal (e.g., square or rectangular, triangular, pentagonal, hexagonal, octagonal, etc.), irregular and/or the like. In some embodiments, the openings are slotted or elongated.

[0320] Regardless of their exact shape, size, orientation, spacing and/or other details, the openings 2123 that comprise the perforated or direct contact region 2122 of the channel 2120 can provide direct contact between the irrigation fluid and the adjacent diamond (and/or another heat shunting member) 1150 for 30% to 70% (e.g., 30-35, 35-40, 40-45, 45-50, 50-55, 55-60, 60-65, 65-70%, percentages between the foregoing ranges, etc.) of the surface area of the perforated or direct contact region 2122 of the channel 2120. In other embodiments, the openings 2123 that comprise the perforated or direct contact region 2122 of the channel 2120 can provide direct contact between the irrigation fluid and the adjacent diamond (and/or another heat shunting member) 2150 for less than 30% (e.g., 1-5, 5-10, 10-15, 15-20, 20-25, 25-30%, percentages between the foregoing ranges, less than 1%, etc.) or greater than 70% (e.g., 70-75, 75-80, 80-85, 85-90, 90-95, 95-99%, percentages between the foregoing ranges, greater than 99%, etc.) of the surface area of the perforated or direct contact region 2122 of the channel 2120, as desired or required. Such a perforated or direct contact region 2122 can be incorporated into any of the embodiments disclosed herein. In addition, any of the embodiments disclosed herein, including, without limitation, the system of FIGS. 16A and 16B, can include more than one perforated or direct contact region 2122. For example, the embodiment of FIGS. 16A and 16B can include a second perforated or direct contact region along the distal end of the proximal slug or electrode 2130 and/or along any other portion adjacent a heat shunting member.

[0321] As illustrated in FIG. 16B, the distal end of an irrigation tube (e.g., a flexible polyurethane or other polymeric conduit) 2104 that is in fluid communication with the irrigation channel 2120 that extends through the distal end of the catheter or other medical instrument can be positioned at least partially within an interior of such a channel 2120. Such a configuration can be incorporated into any of the embodiments disclosed herein or variations thereof. In some embodiments, the distal portion of the irrigation tube 2104

can be sized, shaped and/or otherwise configured to press-fit within an interior of the distal channel **2120**. However, in some embodiments, one or more other attachment devices or methods, such as, for example, adhesives, heat bonding, fasteners, etc., can be used to help secure the irrigation tube **2104** to the irrigation channel **2120**, as desired or required.

[0322] Another embodiment of a distal end of a catheter or other medical instrument **2200** comprising heat shunting characteristics is illustrated in FIG. 16C. As shown, the proximal electrode or slug **2230** extends toward the interior of the catheter (e.g., to or near the irrigation channel **2220**). However, the depicted electrode **2230** is generally thinner than (e.g., does not extend as far as) the embodiment of FIGS. 16A and 16B. In the illustrated embodiment, one or more heating shunting members (e.g., diamond, Graphene, silica, etc.) with favorable thermal diffusivity characteristics are positioned between the interior of the proximal electrode or slug **2230** and the irrigation channel **2220**. Thus, in such an arrangement, not only can heat generated at or along the electrode **2230** and/or the tissue of the subject being treated be more quickly and efficiently transferred away from the electrode and/or tissue, but the diamond or other electrically-insulating heat shunting member or network **2250** provides the necessary electrical insulation between the metallic (e.g., stainless steel) irrigation channel **2220** and the proximal electrode or slug **2230**. As noted herein, such electrical isolation is helpful with a split-tip design.

[0323] A distal portion **2300** of another embodiment of an ablation system is illustrated in FIGS. 17A and 17B. As shown, the system comprises a split-tip design, with a proximal electrode or slug **2330** and a distal electrode **2310**. Further, the catheter or other medical instrument includes one or more heat transfer members **2350**, including, without limitation, a heat shunt network (e.g., comprising diamond, Graphene, silica and/or other materials with favorable thermal diffusivity properties). According to some embodiments, as depicted in the illustrated arrangement, the heat shunt network **2350** can include rings that extend to the exterior of the catheter or instrument and/or one or more interior members that are positioned within (e.g., underneath) the proximal electrode **2330**, as desired or required. In addition, as with other embodiments disclosed herein, one or more temperature sensors **2392**, **2394** can be provided along one or more portions of the system (e.g., along or near the distal electrode **2310**, along or near the proximal heat shunt member, along or near the proximal electrode **2330**, etc.) to help detect the temperature of tissue being treated. As discussed in greater detail in such temperature sensors (e.g., thermocouples) can also be used to detect the orientation of the tip, to determine whether (and/or to what extent) contact is being made between the tip and tissue and/or the like.

[0324] With continued reference to the embodiment of FIGS. 17A and 17B, the catheter or other medical instrument can include a proximal coupling or member **2340**. As shown, such a coupling or member **2340** is configured to connect to and be placed in fluid communication with an irrigation conduit (e.g., polyurethane, other polymeric or other flexible conduit, etc.) **2304**. For example, in the illustrated embodiment, the distal end of the irrigation conduit **2304** is sized, shaped and otherwise configured to be inserted within a proximal end (e.g., recess) of the coupling **2340**. In some embodiments, the irrigation conduit **2304** is press-fit within the recess of the coupling **2340**. In other arrangements, however, one or more other attachment devices or methods

can be used to secure the conduit **2304** to the coupling **2340** (e.g., adhesive, weld, fasteners, etc.), either in lieu or in addition to a press-fit connection, as desired or required. Regardless of the exact mechanism of securement between the irrigation conduit **2304** and the coupling **2340**, fluid passing through the conduit **2304** can enter into a manifold **2342** of the coupling **2340**. In some embodiments, the manifold **2342** can divide the irrigation fluid flow into two or more pathways **2344**. However, in some embodiments, the coupling **2340** does not have a manifold. For example, irrigation fluid entering the coupling **2340** can be routed only along a single fluid pathway, as desired or required.

[0325] In the embodiment of FIGS. 17A and 17B, the manifold (or other flow dividing feature, device or component) **2342** of the coupling **2340** separates the irrigation flow into three different fluid pathways. As shown, each such fluid pathway can be placed in fluid communication with a separate fluid conduit or sub-conduit **2320**. In some embodiments, such fluid conduits **2320** are equally spaced apart (e.g., radially) relative to the centerline of the catheter or other medical instrument. For example, the conduits **2320** can be spaced apart at or approximately at 120 degrees relative to each other. As shown, the conduits **2320** extend, at least partially, through the proximal heat shunt member **2350** and the proximal slug or electrode **2330**. However, in other embodiments, the orientation, spacing and/or other details of the manifold **2342**, **2344** and/or the fluid conduits **2320** can vary. In addition, the number of fluid conduits **2320** originating from the manifold system can be greater than 3 (e.g., 4, 5, 6, 7, greater than 7, etc.) or less than 3 (e.g., 1, 2), as desired or required.

[0326] In some embodiments in which the system comprises an open-irrigation system, as illustrated in the longitudinal cross-sectional view of FIG. 17B, one or more irrigation fluid outlets **2332a**, **2332b**, **2332c** can be provided along one or more of the fluid conduits **2320**. As shown, such fluid outlets **2332** can be provided within the proximal electrode **2330**. However, in other embodiments, such outlets **2332** can be included within one or more other portions of the system (e.g., a heat shunt member **2350**, the distal electrode **2310**, etc.), either in lieu of or in addition to the proximal electrode **2330**. Such a configuration (e.g., one including a manifold and/or openings through the proximal electrode) can be incorporated into any of the ablation system embodiments disclosed herein. As with other irrigation system arrangements disclosed herein, heat can be shunted (e.g., from the electrode, the tissue being treated, one or more other portions of the system, etc.) to the irrigation fluid passing through the conduits and/or fluid outlets to help quickly and efficiently dissipate (e.g., shunt) heat from the system during use. In some embodiments, as illustrated in FIGS. 17A and 17B, the relative size, shape and/or other configuration of two or more of the fluid outlets **2332** can vary. For example, in some arrangements, in order to better balance the fluid hydraulics of fluid passing through each conduit **2320** (e.g., to better balance the flow rate passing through each outlet **2332**), the proximal fluid outlets can be smaller than one or more of the distal fluid outlets. However, in other embodiments, two or more (e.g., most or all) of the fluid outlets **2332** include the identical shape, size and/or other properties.

[0327] In some embodiments, the orientation of the fluid outlets can be skewed relative to the radial direction of the catheter or other medical instrument in which they are

located. Such a skewing or offset can occur for any fluid outlets located along the distal end of the catheter or other medical instrument (e.g., fluid outlets located along the distal electrode as shown in FIGS. 13, 16A and 16B and 16C, fluid outlets located along the proximal electrode as shown in FIGS. 17A and 17B, etc.). The extent to which the outlets are skewed or offset (e.g., relative to the radial direction of the catheter or medical instrument, relative to a direction perpendicular to the longitudinal centerline of the catheter or medical instrument) can vary, as desired or required. By way of example, the fluid openings can be skewed or offset relative to the radial direction by 0 to 60 degrees (e.g., 0-5, 5-10, 10-15, 15-20, 20-25, 25-30, 30-35, 35-40, 40-45, 45-50, 50-55, 55-60 degrees, angles between the foregoing ranges, etc.). In some embodiments, the fluid openings are skewed or offset relative to the radial direction by more than 60 degrees (e.g., 60-65, 65-70, 70-75 degrees, angles between the foregoing ranges, greater than 70 degrees, etc.), as desired or required.

[0328] According to some embodiments, fluid outlets or openings located along or near the distal electrode are skewed or offset distally (e.g., in a direction distal to the location of the corresponding fluid outlet or opening). In some embodiments, fluid outlets or openings located along or near the proximal electrode are skewed or offset proximally (e.g., in a direction proximal to the location of the corresponding fluid outlet or opening). Thus, in some embodiments, irrigation fluid exiting at or near the distal electrodes is delivered in a direction distal to the corresponding fluid outlet(s), and irrigation fluid exiting at or near the proximal electrodes is delivered in a direction proximal to the corresponding fluid outlet(s). In some embodiments, such a configuration can assist with cooling hot spots that may otherwise be created along or near the electrode. Such a configuration could also help dilute the blood in those areas to help reduce the chance of thrombus and/or coagulation formation.

#### Multiple Temperature Sensors

[0329] According to some embodiments, a medical instrument (for example, ablation catheter) can include multiple temperature-measurement devices (for example, thermocouples, thermistors, other temperature sensors) spaced axially at different locations along a distal portion of the medical instrument. The axial spacing advantageously facilitates measurement of a meaningful spatial temperature gradient. Each of the temperature-measurement devices may be isolated from each of the other temperature-measurement devices to provide independent temperature measurements. The temperature-measurement devices may be thermally insulated from one or more energy delivery members (for example, radiofrequency electrodes) so as not to directly measure the temperature of the energy delivery member(s), thereby facilitating temperature measurements that are isolated from the thermal effects of the energy delivery member(s). The medical instrument may comprise a first plurality (for example, set, array, group) of temperature sensors positioned at or adjacent a distal tip, or terminus, of the medical instrument. The first plurality of temperature sensors may be spaced apart (for example, circumferentially, radially) around the medical instrument along a first cross-sectional plane of the medical instrument, in an equidistant manner or non-equidistant manner. The medical instrument may also comprise a second plurality of temperature sensors

spaced proximally from the first plurality of temperature sensors along a second cross-sectional plane of the medical instrument that is proximal of the first cross-sectional plane, thereby allowing for temperature measurements to be obtained at multiple locations. In some embodiments, the second plurality of temperature sensors is positioned adjacent to a proximal end (for example, edge) of the electrode or other energy delivery member (if the medical instrument (for example, ablation catheter) comprises a single electrode or other energy delivery member) or of the proximal-most electrode or other energy delivery member (if the medical instrument comprises multiple electrode members or other energy delivery members).

[0330] The temperature measurements obtained from the temperature sensors may advantageously be used to determine, among other things, an orientation of the distal tip of the medical instrument with respect to a tissue surface, to determine an estimated temperature of a peak temperature zone of a lesion formed by the medical instrument (for example, ablation catheter), and/or an estimated location of the peak temperature zone of the lesion. In some embodiments, the determinations made using the temperature sensors or other temperature-measurement devices can be used to adjust treatment parameters (for example, target temperature, power, duration, orientation) so as to prevent char or thrombus if used in a blood vessel and/or to control lesion parameters (for example, depth, width, location of peak temperature zone, peak temperature), thus providing more reliable and safer treatment (for example, ablation) procedures. Accordingly, upon implementation of a control scheme that regulates the delivery of power or other parameters to an energy delivery member (for example, RF electrode, microwave emitter, ultrasound transducer, cryogenic emitter, other emitter, etc.) located along the distal end of a medical apparatus (for example, catheter, probe, etc.), the target level of treatment can be accomplished without negatively impacting (for example, overheating, over-treating, etc.) the subject's tissue (for example, within and/or adjacent a treatment volume).

[0331] The term peak temperature, as used herein, can include either a peak or high temperature (for example, a positive peak temperature) or a trough or low temperature (for example, negative peak temperature). As a result, determination of the peak temperature (for example, maximum or minimum temperature or other extreme temperature) within targeted tissue can result in a safer, more efficient and more efficacious treatment procedure. In some embodiments, when, for example, cryoablation is performed, the systems, devices and/or methods disclosed herein can be used to determine the trough or lowest temperature point, within the treatment (for example, ablation) volume. In some embodiments, technologies that cool tissue face similar clinical challenges of controlling the tissue temperature within an efficacious and safe temperature range. Consequently, the various embodiments disclosed herein can be used with technologies that either cool or heat targeted tissue.

[0332] Several embodiments of the invention are particularly advantageous because they include one, several or all of the following benefits: (i) reduction in proximal edge heating, (ii) reduced likelihood of char or thrombus formation, (iii) providing feedback that may be used to adjust ablation procedures in real time, (iv) provides noninvasive temperature measurements, (v) does not require use of radiometry; (vi) provides safer and more reliable ablation

procedures; and (vii) tissue temperature monitoring and feedback during irrigated or non-irrigated ablation.

[0333] For any of the embodiments disclosed herein, a catheter or other minimally-invasive medical instrument can be delivered to the target anatomical location of a subject (for example, atrium, pulmonary veins, other cardiac location, renal artery, other vessel or lumen, etc.) using one or more imaging technologies. Accordingly, any of the ablation systems disclosed herein can be configured to be used with (for example, separately from or at least partially integrated with) an imaging device or system, such as, for example, fluoroscopy technologies, intracardiac echocardiography (“ICE”) technologies and/or the like. In some embodiments, energy delivery is substituted with fluid delivery (for example, hot fluid, cryogenic fluid, chemical agents) to accomplish treatment.

[0334] FIG. 18A illustrates a perspective view of a distal portion of an open-irrigated ablation catheter 3120A comprising multiple temperature-measurement devices 3125, according to one embodiment. As shown, the embodiment of the ablation catheter 3120A of FIG. 18A is an open-irrigated catheter comprising a split-tip electrode design. The split-tip electrode design comprises a dome- or hemispherical-shaped distal tip electrode member 3130, an insulation gap 3131 and a proximal electrode member 3135. The ablation catheter 3120A comprises multiple irrigation ports 3140 and a thermal transfer member 3145.

[0335] The temperature-measurement devices 3125 comprise a first (for example, distal) group of temperature-measurement devices 3125A positioned in recesses or apertures formed in the distal electrode member 3130 and a second (for example, proximal) group of temperature-measurement devices 3125B positioned in slots, notches or openings formed in the thermal transfer member 3145 proximate or adjacent the proximal edge of the proximal electrode member 3135. The temperature-measurement devices 3125 may comprise thermocouples, thermistors, fluoroptic sensors, resistive temperature sensors and/or other temperature sensors. In various embodiments, the thermocouples comprise nickel alloy, platinum/rhodium alloy, tungsten/rhenium alloy, gold/iron alloy, noble metal alloy, platinum/molybdenum alloy, iridium/rhodium alloy, pure noble metal, Type K, Type T, Type E, Type J, Type M, Type N, Type B, Type R, Type S, Type C, Type D, Type G, and/or Type P thermocouples. A reference thermocouple may be positioned at any location along the catheter 120A (for example, in a handle or within a shaft or elongate member of the catheter 3120A). In one embodiment, the reference thermocouple is thermally insulated and/or electrically isolated from the electrode member(s). The electrode member (s) may be substituted with other energy delivery members.

[0336] In some embodiments, the temperature-measurement devices are thermally insulated from the electrode members 3130, 3135 so as to isolate the temperature measurements from the thermal effects of the electrode members (for example, to facilitate measurement of surrounding temperature, such as tissue temperature, instead of measuring temperature of the electrode members). As shown, the temperature-measurement devices 3125 may protrude or extend outward from an outer surface of the ablation catheter 3120A. In some embodiments, the temperature-measurement devices 3125 may protrude up to about 1 mm away from the outer surface (for example, from about 0.1 mm to about 0.5 mm, from about 0.5 mm to about 1 mm, from

about 0.6 mm to about 0.8 mm, from about 0.75 mm to about 1 mm, or overlapping ranges thereof). The dome shape of the distal tip electrode member 3130 and/or the outward protrusion or extension of the temperature-measurement devices 3125 may advantageously allow the temperature-measurement devices to be buried deeper into tissue and away from effects of the open irrigation provided by irrigation ports 3140, in accordance with several embodiments. The proximal group of temperature-measurement devices and the distal group of temperature-measurement devices may protrude the same amount or different amounts (as a group and/or individually within each group). In other embodiments, the temperature-measurement devices 3125 are flush or embedded within the outer surface (for example, 0.0 mm, -0.1 mm, -0.2 mm, -0.3 mm, -0.4 mm, -0.5 mm from the outer surface).

[0337] With reference to FIG. 18D, a portion of the ablation catheter 3120C where the temperature-measurement devices 3125 are positioned may have a larger outer diameter or other outer cross-sectional dimension than adjacent portions of the ablation catheter 3120C so as to facilitate deeper burying of the temperature-measurement devices within tissue and to further isolate the temperature measurements from the thermal effects of the electrode members or fluid (for example, saline or blood). As shown in FIG. 18D, the portion of the ablation catheter 3120C comprising the proximal group of temperature-measurement devices 3125B comprises a bulge, ring or ridge 3155 having a larger outer diameter than adjacent portions.

[0338] In some embodiments, the temperature-measurement devices 3125 are adapted to be advanced outward and retracted inward. For example, the temperature-measurement devices 3125 may be in a retracted position (within the outer surface or slightly protruding outward) during insertion of the ablation catheter and movement to the treatment location to reduce the outer profile and facilitate insertion to the treatment location and may be advanced outward when at the treatment location. The features described above in connection with ablation catheter 3120C of FIG. 18D may be employed with any of the other ablation catheters described herein.

[0339] Returning to FIG. 18A, the proximal and distal groups of temperature-measurement devices 3125 may each comprise two, three, four, five, six, or more than six temperature-measurement devices. In the illustrated embodiment, the proximal and distal groups of temperature-measurement devices 3125 each consist of three temperature-measurement devices, which may provide a balance between volumetric coverage and reduced number of components, according to one embodiment. The number of temperature-measurement devices may be selected to balance accuracy, complexity, volumetric coverage, variation in tip to tissue apposition, cost, number of components, and/or size constraints. As shown in FIG. 18A, the temperature-measurement devices may be equally spaced apart around a circumference of the ablation catheter 3120A or spaced an equal number of degrees apart from each other about a central longitudinal axis extending from a proximal end to a distal end of the ablation catheter. For example, when three temperature-measurement devices are used, they may be spaced about 120 degrees apart and when four temperature-measurement devices are used, they may be spaced about 90 degrees apart. In other embodiments, the temperature-measurement devices 3125 are not spaced apart equally.

[0340] As shown in the embodiment of FIG. 18A, the temperature-measurement devices 3125 of each group may be positioned along the same cross-sectional plane of the ablation catheter 3120A. For example, the distal temperature-measurement devices 3125A may be positioned to extend the same distance outward from the dome-shaped surface and the proximal temperature-measurement devices 3125B may each be spaced the same distance from the distal tip of the ablation catheter 3120A. As shown in the embodiment of FIG. 18A, the distal temperature-measurement devices 3125A extend in axial direction that is parallel or substantially parallel with a central longitudinal axis of the distal portion of the ablation catheter 3120A and the proximal temperature-measurement devices 3125B extend radially outward from the outer surface of the ablation catheter 3120A. In other embodiments, the distal temperature-measurement devices 3125A may not be positioned on the distal surface of the distal terminus but may be positioned on a lateral surface to extend radially outward (similar to the illustrated proximal temperature-measurement devices 3125B).

[0341] As shown in the embodiment of FIG. 18A, the distal temperature-measurement devices 3125A may be positioned distal of the insulation gap 3131 and/or of the irrigation ports 3140 and the proximal temperature-measurement devices 3125B may be positioned proximal to the distal edge of the proximal electrode member 3135 within the thermal transfer member 3145. In other embodiments (for example, as shown in FIGS. 22A and 22B), the proximal temperature-measurement devices 3125B may be positioned distal to the distal edge of the proximal electrode member 3135 (for example, within recesses or apertures formed within the proximal electrode member 3135 similar to the recesses or apertures formed in the distal tip electrode member illustrated in FIG. 18A). In other embodiments, the distal temperature-measurement devices 3125A and/or the proximal temperature-measurement devices 3125B may be positioned at other locations along the length of the ablation catheter 3120A. In some embodiments, each distal temperature-measurement device 3125A is axially aligned with one of the proximal temperature-measurement devices 3125B and the spacing between the distal temperature-measurement devices 3125A and the proximal temperature-measurement devices is uniform or substantially uniform.

[0342] The irrigation ports 3140 may be spaced apart (equidistant or otherwise) around a circumference of the shaft of the ablation catheter 3120A. The irrigation ports 3140 are in communication with a fluid source, such as a fluid source provided by the irrigation fluid system 70 of FIG. 1. The irrigation ports facilitate open irrigation and provide cooling to the electrode members 3130, 3135 and any blood surrounding the electrode members 3130, 3135. In some embodiments, the ablation catheter 3120A comprises three, four, five, six, seven, eight or more than eight exit ports 3140. In various embodiments, the exit ports 3140 are spaced between 0.005 and 0.015 inches from the proximal edge of the distal electrode member 3130 so as to provide improved cooling of the thermal transfer member 3145 at the tissue interface; however, other spacing can be used as desired and/or required. In other embodiments, the exit ports 3140 are spaced apart linearly and/or circumferentially along the proximal electrode member 3135 (as shown, for example, in FIG. 18E).

[0343] FIGS. 18B and 18C illustrate a perspective view and a cross-sectional view, respectively, of a distal portion of an open-irrigated ablation catheter 3120B having multiple temperature-measurement devices, according to another embodiment. The ablation catheter 3120B may include all of the structural components, elements and features of the ablation catheter 3120A described above and ablation catheter 3120A may include all of the structural components, elements and features described in connection with FIGS. 18B and 18C. The ablation catheter 3120B comprises a flat tip electrode member 3130 instead of a dome-shaped tip electrode member as shown in FIG. 18A.

[0344] As best shown in FIG. 18C, the thermal transfer member 3145 is in thermal contact with one or both of the electrode members 3130, 3135. The thermal transfer member 3145 can extend to, near or beyond the proximal end of the proximal electrode member 3135. In some embodiments, the thermal transfer member 3145 terminates at or near the proximal end of the proximal electrode member 3135. However, in other arrangements (as shown in FIG. 18C), the thermal transfer member 3145 extends beyond the proximal end of the proximal electrode member 3135. In yet other embodiments, the thermal transfer member 3145 terminates distal of the proximal end (for example, edge) of the proximal electrode member 3135. The thermal transfer member 3145 may extend from the proximal surface of the tip electrode member 3130 to location beyond the proximal end of the proximal electrode member 3135. Embodiments wherein the thermal transfer member 3145 extends beyond the proximal end of the proximal electrode member 3135 may provide increased shunting of proximal edge heating effects caused by the increased amount of current concentration at the proximal edge by reducing the heat at the proximal edge through conductive cooling. In some embodiments, at least a portion of the thermal transfer member 3145 is in direct contact with the tissue (for example, within insulation gap 3131) and can remove or dissipate heat directly from the targeted tissue being heated.

[0345] The thermal transfer member 3145 can comprise one or more materials that include favorable heat transfer properties. For example, in some embodiments, the thermal conductivity of the material(s) included in the thermal transfer member is greater than 300 W/m<sup>o</sup> C. (for example, 300-350, 350-400, 400-450, 450-500, 500-600, 600-700 W/m<sup>o</sup> C., ranges between the foregoing, greater than 700 W/m<sup>o</sup> C., etc.).

[0346] Possible materials with favorable thermal conductivity properties include, but are not limited to, copper, brass, beryllium, other metals and/or alloys, alumina ceramics, other ceramics, industrial diamond and/or other metallic and/or non-metallic materials.

[0347] According to certain embodiments where the heat transfer members comprise heat shunting members, the thermal diffusivity of the material(s) included in the heat shunt members and/or of the overall heat shunt assembly (for example, when viewed as a unitary member or structure) is greater than 1.5 cm<sup>2</sup>/sec (for example, 1.5-2, 2-2.5, 2.5-3, 3-4, 4-5, 5-6, 6-7, 7-8, 8-9, 9-10, 10-11, 11-12, 12-13, 13-14, 14-15, 15-20 cm<sup>2</sup>/sec, values between the foregoing ranges, greater than 20 cm<sup>2</sup>/sec). Thermal diffusivity measures the ability of a material to conduct thermal energy relative to its ability to store thermal energy. Thus, even though a material can be efficient as transferring heat (for example, can have a relatively high thermal conductivity), it

may not have favorable thermal diffusivity properties, because of its heat storage properties. Heat shunting, unlike heat transferring, requires the use of materials that possess high thermal conductance properties (for example, to quickly transfer heat through a mass or volume) and a low heat capacity (for example, to not store heat). Possible materials with favorable thermal diffusivity, and thus favorable heat shunting properties, include, but are not limited to, industrial diamond, graphene, silica alloys, ceramics, other carbon-based materials and/or other metallic and/or non-metallic materials. In various embodiments, the material used for the heat transfer (for example, diamond) provides increased visibility of the catheter tip using ICE imaging or other imaging techniques.

**[0348]** The use of materials with favorable thermal diffusivity properties can help ensure that heat can be efficiently transferred away from the electrode and/or the adjacent tissue during a treatment procedure. In contrast, materials that have favorable thermal conductivity properties, but not favorable thermal diffusivity properties, such as, for example, copper, other metals or alloys, thermally conductive polypropylene or other polymers, etc., will tend to retain heat. As a result, the use of such materials that store heat may cause the temperature along the electrode and/or the tissue being treated to be maintained at an undesirably elevated level (for example, over 75 degrees C.) especially over the course of a relatively long ablation procedure, which may result in charring, thrombus formation and/or other heat-related problems.

**[0349]** Industrial diamond and other materials with the requisite thermal diffusivity properties for use in a thermal shunting network, as disclosed in the various embodiments herein, comprise favorable thermal conduction characteristics. Such favorable thermal conduction aspects emanate from a relatively high thermal conductance value and the manner in which the heat shunt members of a network are arranged with respect to each other within the tip and with respect to the tissue. For example, in some embodiments, as radiofrequency energy is emitted from the tip and the ohmic heating within the tissue generates heat, the exposed distal most shunt member (for example, located 0.5 mm from the distal most end of the tip) can actively extract heat from the lesion site. The thermal energy can advantageously transfer through the shunting network in a relatively rapid manner and dissipate through the shunt residing beneath the radiofrequency electrode surface the heat shunt network, through a proximal shunt member and/or into the ambient surroundings. Heat that is shunting through an interior shunt member can be quickly transferred to an irrigation conduit extending through an interior of the catheter or other medical instrument. In other embodiments, heat generated by an ablation procedure can be shunted through both proximal and distal shunt members (for example, shunt members that are exposed to an exterior of the catheter or other medical instrument, such as shown in many of the embodiments herein).

**[0350]** Further, as noted above, the materials with favorable thermal diffusivity properties for use in a heat shunt network not only have the requisite thermal conductivity properties but also have sufficiently low heat capacity values. This helps ensure that the thermal energy is dissipated very quickly from the tip to tissue interface as well as the hot spots on the electrode, without heat retention in the heat shunting network. The thermal conduction constitutes the

primary heat dissipation mechanism that ensures quick and efficient cooling of the tissue surface and of the radiofrequency electrode surface. Conversely a heat transfer (for example, with relatively high thermal conductivity characteristics but also relatively high heat capacity characteristics) will store thermal energy. Over the course of a long ablation procedure, such stored heat may exceed 75 degrees Celsius. Under such circumstances, thrombus and/or char formation can undesirably occur.

**[0351]** The thermal convection aspects of the various embodiments disclosed herein two-fold. First, an irrigation lumen of the catheter can absorb thermal energy which is transferred to it through the shunt network. Such thermal energy can then be flushed out of the distal end of the electrode tip via the irrigation ports. In closed irrigation systems, however, such thermal energy can be transferred back to a proximal end of the catheter where it can be removed. Second, the exposed shunt surfaces along an exterior of the catheter or other medical instrument can further assist with the dissipation of heat from the electrode and/or the tissue being treated. For example, such heat dissipation can be accomplished via the inherent convective cooling aspects of the blood flowing over the surfaces of the electrode.

**[0352]** Accordingly, the use of materials in a heat shunting network with favorable thermal diffusivity properties, such as industrial diamond, can help ensure that heat is quickly and efficiently transferred away from the electrode and treated tissue, while maintaining the heat shunting network cool (for example, due to its low heat capacity properties). This can create a safer ablation catheter and related treatment method, as potentially dangerous heat will not be introduced into the procedure via the heat shunting network itself.

**[0353]** In some embodiments, the heat shunt members disclosed herein draw out heat from the tissue being ablated and shunt it into the irrigation channel. Similarly, heat is drawn away from the potential hot spots that form at the edges of electrodes and are shunted through the heat shunt network into the irrigation channel. From the irrigation channel, via convective cooling, heat can be advantageously released into the blood stream and dissipated away. In closed irrigation systems, heat can be removed from the system without expelling irrigation fluid into the subject.

**[0354]** According to some embodiments, the various heat shunting systems disclosed herein rely on heat conduction as the primary cooling mechanism. Therefore, such embodiments do not require a vast majority of the heat shunting network to extend to an external surface of the catheter or other medical instrument (for example, for direct exposure to blood flow). In fact, in some embodiments, the entire shunt network can reside within an interior of the catheter tip (i.e., with no portion of the heat shunt network extending to an exterior of the catheter or other medical instrument). Further, the various embodiments disclosed herein do not require electrical isolation of the heat shunts from the electrode member or from the irrigation channel.

**[0355]** As shown in FIG. 18C, the thermal transfer member 3145 is also in thermal contact with a heat exchange chamber (for example, irrigation conduit) 3150 extending along an interior lumen of the ablation catheter 3120B. For any of the embodiments disclosed herein, at least a portion of a thermal transfer member (for example, heat shunt member) that is in thermal communication with the heat

exchange chamber **3150** extends to an exterior surface of the catheter, adjacent to (and, in some embodiments, in physical and/or thermal contact with) one or more electrodes or other energy delivery members. Such a configuration, can further enhance the cooling of the electrode(s) or other energy delivery member(s) when the system is activated, especially at or near the proximal end of the electrode(s) or energy delivery member(s), where heat may otherwise tend to be more concentrated (for example, relative to other portions of the electrode or other energy delivery member). According to some embodiments, thermal conductive grease and/or any other thermally conductive material (for example, thermally-conductive liquid or other fluid, layer, member, coating and/or portion) can be used to place the thermal transfer member **3145** in thermal communication with the heat exchange chamber (for example, irrigation conduit) **3150**, as desired or required. In such embodiments, such a thermally conductive material places the electrode members **3130**, **3135** in thermal communication, at least partially, with the irrigation conduit **3150**.

[0356] The irrigation conduit(s) **3150** can be part of an open irrigation system, in which fluid exits through the exit ports or openings **3140** along the distal end of the catheter (for example, at or near the electrode member **3130**) to cool the electrode members and/or the adjacent targeted tissue. In various embodiments, the irrigation conduit **3150** comprises one or more metallic and/or other favorable heat transfer (for example, heat shunting) materials (for example, copper, stainless steel, other metals or alloys, ceramics, polymeric and/or other materials with relatively favorable heat transfer properties, etc.). The irrigation conduit **3150** can extend beyond the proximal end of the proximal electrode member **3135** and into the proximal portion of the thermal transfer member **3145**. The inner wall of the irrigation conduit **3150** may comprise a biocompatible material (such as stainless steel) that forms a strong weld or bond between the irrigation conduit **3150** and the material of the electrode member(s).

[0357] In some embodiments, the ablation catheters **3120** only comprise irrigation exit openings **3140** along a distal end of the catheter (for example, along a distal end of the distal electrode member **3130**). In some embodiments, the system does not comprise any irrigation openings along the thermal transfer member **3145**.

[0358] The thermal transfer member **3145** may advantageously facilitate thermal conduction away from the electrode members **3130**, **3135**, thereby further cooling the electrode members **3130**, **3135** and reducing the likelihood of char or thrombus formation if the electrode members are in contact with blood. The thermal transfer member **3145** may provide enhanced cooling of the electrode members **3130**, **3135** by facilitating convective heat transfer in connection with the irrigation conduit **3150** in addition to thermal conduction.

[0359] Heat transfer (for example, heat shunting) between the thermal transfer member **3145** and the electrode members **3130**, **3135** can be facilitated and otherwise enhanced by eliminating air gaps or other similar spaces between the electrode members and the thermal transfer member. For example, one or more layers of an electrically conductive material (for example, platinum, gold, other metals or alloys, etc.) may be positioned between the interior of the electrode member and the exterior of the thermal transfer member **3145**. Such layer(s) can be continuously or intermittently applied between the electrode member (or another type of

ablation member) and the adjacent thermal transfer member. Further, such layer(s) can be applied using one or more methods or procedures, such as, for example, sputtering, other plating techniques and/or the like. Such layer(s) can be used in any of the embodiments disclosed herein or variations thereof. In addition, the use of a heat shunting network specifically can help transfer heat away from the tissue being treated by the electrode member(s) without itself absorbing heat.

[0360] In some embodiments, the ablation catheter **3120** comprises multiple thermal transfer members **3145** (for example, heat shunt disks or members). For example, according to some embodiments, such additional heat transfer members may be positioned proximal of thermal transfer member **3145** and may comprise one or more fins, pins and/or other members that are in thermal communication with the irrigation conduit **3150** extending through an interior of the ablation catheter. Accordingly, as with the thermal transfer members **3145** positioned in contact with the electrode members **3130**, **3135** heat can be transferred and thus removed or dissipated, from other energy delivery members or electrodes, the adjacent portions of the catheter and/or the adjacent tissue of the subject via these additional heat transfer members (for example, heat shunting members). In other embodiments, ablation catheters do not comprise any thermal transfer members.

[0361] In some embodiments, for any of the ablation catheters disclosed herein or variations thereof, one or more of the thermal transfer members (for example, heat shunting members) that facilitate the heat transfer to a heat exchange chamber (for example, irrigation conduit) of the catheter are in direct contact with the electrode members and/or the heat exchange chamber. However, in other embodiments, one or more of the thermal transfer members do not contact the electrode members and/or the irrigation conduit. Thus, in such embodiments, the thermal transfer members are in thermal communication with the electrode members or single electrode and/or irrigation conduit, but not in physical contact with such components. For example, in some embodiments, one or more intermediate components, layers, coatings and/or other members are positioned between a thermal transfer member (for example, heat shunting member) and the electrode (or other ablation member) and/or the irrigation conduit. In some embodiments, irrigation is not used at all due to the efficiency of the thermal transfer members. For example, where multiple levels or stacks of thermal transfers are used, the heat may be dissipated over a larger area along the length of the ablation catheter. Additional details regarding function and features of thermal transfer members (for example, heat shunting members) are provided herein. The features of the various embodiments disclosed therein (for example, of thermal shunt systems and members) may be implemented in any of the embodiments of the medical instruments (for example, ablation catheters) disclosed herein.

[0362] As best shown in FIGS. **18C**, **18E** and **18F**, the temperature-measurement devices **3125** are thermally insulated from the electrode members **3130**, **3135** by tubing **3160** and/or air gaps. In some embodiments, the tubing **3160** extends along an entire length (and beyond in some embodiments) of the electrode members **3130**, **3135** such that no portion of the electrode member is in contact with the temperature-measurement devices **3125**, thereby isolating the temperature measurements from the thermal effects of

the electrode members. The outer tubing **3160** of the temperature-measurement devices may comprise an insulating material having low thermal conductivity (for example, polyimide, ULTEM™, polystyrene or other materials having a thermal conductivity of less than about 0.5 W/mPK). The tubing **3160** is substantially filled with air or another gas having very low thermal conductivity. The distal tip **3165** of the temperature-sensing device (for example, the portion where the temperature is sensed) may comprise an epoxy polymer covering or casing filled with a highly conductive medium (for example, nanotubes comprised of graphene, carbon or other highly thermally conductive materials or films) to increase thermal conduction at a head of the temperature-measurement device where temperature is measured. In some embodiments, the distal tip **3165** comprises an epoxy cap having a thermal conductivity that is at least 1.0 W/mPK. The epoxy may comprise metallic paste (for example, containing aluminum oxide) to provide the enhanced thermal conductivity. In some embodiments, the distal tip **3165** or cap creates an isothermal condition around the temperature-measurement device **3125** that is close to the actual temperature of tissue in contact with the temperature-measurement device. Because the distal tip **3165** of each temperature-measurement device **3125** is isolated from thermal conductive contact with the electrode member(s), it retains this isothermal condition, thereby preventing or reducing the likelihood of dissipation by the thermal mass of the electrode member(s). FIGS. **18E** and **18F** illustrate a perspective view and a cross-sectional view, respectively, of a distal portion of an ablation catheter showing isolation of the distal temperature-measurement devices from an electrode tip, according to one embodiment. As shown, the distal temperature measurement devices **3125A** may be surrounded by air gaps or pockets **3162** and/or insulation. The outer tubing **3160** may comprise an insulation sleeve that extends along the entire length, or at least a portion of the length, of the distal electrode member **3130**. The sleeve may extend beyond the distal electrode member **3130** or even to or beyond the proximal electrode member **3135**.

**[0363]** The electrode member(s) (for example, the distal electrode **3130**) can be electrically coupled to an energy delivery module (for example, energy delivery module **40** of FIG. **1**). As discussed herein, the energy delivery module **40** can comprise one or more components or features, such as, for example, an energy generation device **42** that is configured to selectively energize and/or otherwise activate the energy delivery members (for example, RF electrodes), one or more input/output devices or components, a processor (for example, a processing or control unit) that is configured to regulate one or more aspects of the treatment system, a memory and/or the like. Further, such a module can be configured to be operated manually or automatically, as desired or required.

**[0364]** The temperature-measurement devices **3125** can be coupled to one or more conductors (for example, wires, cables, etc.) that extend along the length of the ablation catheter **3120** and communicate the temperature signals back to a processing device (for example, processor **46** of FIG. **1**) for determining temperature measurements for each of the temperature-measurement devices, as will be discussed in greater detail below.

**[0365]** According to some embodiments, the relative length of the different electrodes or electrode members **3130**, **3135** can vary. For example, the length of the proximal

electrode member **3135** can be between 1 to 20 times (for example, 1-2, 2-3, 3-4, 4-5, 5-6, 6-7, 7-8, 8-9, 9-10, 10-11, 11-12, 12-13, 13-14, 14-15, 15-16, 16-17, 17-18, 18-19, 19-20, values between the foregoing ranges, etc.) the length of the distal electrode member **3130**, as desired or required. In yet other embodiments, the lengths of the distal and proximal electrode members **3130**, **3135** are about equal. In some embodiments, the distal electrode member **3130** is longer than the proximal electrode member **3135** (for example, by 1 to 20 times, such as, for example, 1-2, 2-3, 3-4, 4-5, 5-6, 6-7, 7-8, 8-9, 9-10, 10-11, 11-12, 12-13, 13-14, 14-15, 15-16, 16-17, 17-18, 18-19, 19-20, values between the foregoing ranges, etc.).

**[0366]** In some embodiments, the distal electrode member **3130** is 0.5 mm long. In other embodiments, the distal electrode member **130** is between 0.1 mm and 1 mm long (for example, 0.1-0.2, 0.2-0.3, 0.3-0.4, 0.4-0.5, 0.5-0.6, 0.6-0.7, 0.7-0.8, 0.8-0.9, 0.9-1 mm, values between the foregoing ranges, etc.). In other embodiments, the distal electrode member **3130** is greater than 1 mm in length, as desired or required. In some embodiments, the proximal electrode member **3135** is 2 to 4 mm long (for example, 2-2.5, 2.5-3, 3-3.5, 3.5-4 mm, lengths between the foregoing, etc.). However, in other embodiments, the proximal electrode member **3135** is greater than 4 mm (for example, 4-5, 5-6, 6-7, 7-8, 8-9, 9-10 mm, greater than 10 mm, etc.) or smaller than 1 mm (for example, 0.1-0.5, 0.5-1, 1-1.5, 1.5-2 mm, lengths between the foregoing ranges, etc.), as desired or required. In embodiments where the split electrodes are located on catheter shafts, the length of the electrode members can be 1 to 5 mm (for example, 1-2, 2-3, 3-4, 4-5 mm, lengths between the foregoing, etc.). However, in other embodiments, the electrode members can be longer than 5 mm (for example, 5-6, 6-7, 7-8, 8-9, 9-10, 10-15, 15-20 mm, lengths between the foregoing, lengths greater than 20 mm, etc.), as desired or required.

**[0367]** The electrode member(s) may be energized using one or more conductors (for example, wires, cables, etc.). For example, in some arrangements, the exterior of the irrigation conduit **3150** comprises and/or is otherwise coated with one or more electrically conductive materials (for example, copper, other metal, etc.). Thus, the conductor can be placed in contact with such a conductive surface or portion of the irrigation conduit **3150** to electrically couple the electrode member(s) to an energy delivery module. However, one or more other devices and/or methods of placing the electrode member(s) in electrical communication with an energy delivery module can be used. For example, one or more wires, cables and/or other conductors can directly or indirectly couple to the electrode member(s), without the use of the irrigation conduit.

**[0368]** The use of a split tip design can permit a user to simultaneously ablate or otherwise thermally treat targeted tissue and map (for example, using high-resolution mapping) in a single configuration. Thus, such systems can advantageously permit precise high-resolution mapping (for example, to confirm that a desired level of treatment occurred) during a procedure. In some embodiments, the split tip design that includes two electrode members or electrode portions **3130**, **3135** can be used to record a high-resolution bipolar electrogram. For such purposes, the two electrodes or electrode portions can be connected to the inputs of an electrophysiology (EP) recorder. In some embodiments, a relatively small separation distance (for

example, gap G) between the electrode members or electrode portions 3130, 3135 enables high-resolution mapping. The features of any of the embodiments disclosed therein may be implemented in any of the embodiments disclosed herein.

[0369] In some embodiments, a medical instrument (for example, a catheter) 3120 can include three or more electrode members or electrode portions (for example, separated by gaps), as desired or required. According to some embodiments, regardless of how many electrodes or electrode portions are positioned along a catheter tip, the electrode members or electrode portions 3130, 3135 are radiofrequency electrodes and comprise one or more metals, such as, for example, stainless steel, platinum, platinum-iridium, gold, gold-plated alloys and/or the like.

[0370] According to some embodiments, the electrode members or electrode portions 3130, 3135 are spaced apart from each other (for example, longitudinally or axially) using the gap (for example, an electrically insulating gap) 3131. In some embodiments, the length of the gap 3131 (or the separation distance between adjacent electrode members or electrode portions) is 0.5 mm. In other embodiments, the gap or separation distance is greater or smaller than 0.5 mm, such as, for example, 0.1-1 mm (for example, 0.1-0.2, 0.2-0.3, 0.3-0.4, 0.4-0.5, 0.5-0.6, 0.6-0.7, 0.7-0.8, 0.8-0.9, 0.9-1.0 mm, values between the foregoing ranges, less than 0.1 mm, greater than 1 mm, etc.), as desired or required.

[0371] According to some embodiments, a separator is positioned within the gap 3131 between the adjacent electrode members or electrode portions 3130, 3135. The separator can comprise one or more electrically insulating materials, such as, for example, Teflon, polyetheretherketone (PEEK), diamond, epoxy, polyetherimide resins (for example, ULTEM™), ceramic materials, polyimide and the like. As shown in FIGS. 18A-18C and 19A-19C, the separator may comprise a portion of the thermal transfer member 3145 extending within the gap 3131.

[0372] As noted above with respect to the gap 3131 separating the adjacent electrode members or electrode portions, the insulating separator can be 0.5 mm long. In other embodiments, the length of the separator can be greater or smaller than 0.5 mm (for example, 0.1-0.2, 0.2-0.3, 0.3-0.4, 0.4-0.5, 0.5-0.6, 0.6-0.7, 0.7-0.8, 0.8-0.9, 0.9-1.0 mm, values between the foregoing ranges, less than 0.1 mm, greater than 1 mm, etc.), as desired or required.

[0373] According to some embodiments, to ablate or otherwise heat or treat targeted tissue of a subject successfully with the split tip electrode design, such as the ones depicted in FIGS. 18A-18C and 19A-19C, the two electrode members or electrode portions 3130, 3135 are electrically coupled to each other at the RF frequency. Thus, the two electrode members or electrode portions can advantageously function as a single longer electrode at the RF frequency. Additional details regarding function and features of a split-tip electrode design are provided herein.

[0374] FIGS. 19A-19C illustrate a distal portion of closed-irrigation ablation catheters 3220 having multiple temperature-measurement devices 3225, according to various embodiments. The embodiment of the ablation catheter 3220A of FIG. 19A comprises a dome-shaped tip electrode member 3230 similar to the ablation catheter 3120A of FIG. 18A. The embodiment of the ablation catheter 3220B of FIGS. 19B and 19C comprises a flat tip electrode member similar to the ablation catheter 3120B of FIGS. 18B and

18C. The ablation catheters 3220A and 3220B include similar components and features as those described above in connection with FIGS. 18A-18C. For example, temperature-measurement devices 3225 correspond to temperature-measurement devices 3125, electrode members 3230, 3235 correspond to electrode members 3130, 3135, thermal transfer member 3245 corresponds to thermal transfer member 3145 and irrigation conduit 3250 corresponds to irrigation conduit 3150. Accordingly, these features will not be described again in connection with FIGS. 19A-19C. The ablation catheter 3220 does not include irrigation ports because it operates as a closed irrigation device.

[0375] The ablation catheter 3220 comprises two lumens 3265 within the irrigation conduit 3250, an inlet lumen (for example, fluid delivery channel) 3265A and an outlet lumen (for example, return channel) 3265B. As illustrated in the cross-sectional view of FIG. 19C, the outlet of the inlet lumen 3265A and the inlet of the outlet lumen 3265B terminate at spaced-apart locations within the irrigation conduit 3250. The outlet of the inlet lumen 3265A terminates within the distal electrode member 3230 or adjacent to a proximal end surface of the distal electrode member 3230. The inlet of the outlet lumen terminates proximal to the proximal end of the proximal electrode member 3235. The offset spacing of the distal ends of the lumens 3265 advantageously induces turbulence, vortexing or other circulating fluid motions or paths within the irrigation conduit, thereby facilitating enhanced cooling by circulating the fluid to constantly refresh or exchange the fluid in contact with the thermal transfer member 3245 and/or electrode members.

[0376] In accordance with several embodiments, ablation catheters having multiple temperature-measurement devices do not require a split-tip electrode design and/or thermal transfer members. FIG. 20 illustrates a perspective view of a distal portion of an open-irrigated ablation catheter 3320 that does not include a split-tip electrode design or a thermal transfer member. The ablation catheter 3320 comprises a first (for example, distal) plurality of temperature-measurement devices 3325A and a second (for example, proximal) plurality of temperature-measurement devices 3325B. The temperature-measurement devices 3325 comprise similar features, properties, materials, elements and functions as the temperature-measurement devices 3125, 3225 (FIGS. 18A-19C). The ablation catheter 3320 may comprise or consist of a single unitary tip electrode 3330. The tip electrode 3330 may comprise apertures, slots, grooves, bores or openings for the temperature-measurement devices 3325 at their respective spaced-apart locations. As shown in FIG. 20, the proximal temperature-measurement devices 3325B are positioned distal but adjacent to the proximal edge of the tip electrode 3330. The proximal temperature-measurement devices 3325B could be positioned within 1 mm of the proximal edge (for example, within 0.9, 0.8, 0.7, 0.6, 0.5, 0.4, 0.3, 0.2, 0.1 mm, depending on the length of the tip electrode 3330). In other embodiments, the proximal temperature-measurement devices 3325B are positioned proximal of the proximal edge of the tip electrode 3330 and within the same distance as described above of distal placement. In various embodiments, the temperature-measurement devices are positioned at or near the proximal and distal edges of the electrode or split-tip electrode assembly because those locations tend to be the hottest. Based on manufacturing tolerances, these temperature measurement devices may be embedded at the proximal or distal edge of

the electrode **3330**. Accordingly, positioning of the temperature-measurement devices at or near these locations may facilitate prevention, or reduced likelihood, of overheating or char or thrombus formation. Additionally, such temperature-measurement device placement offers the ability to monitor tissue temperature during irrigated ablation.

**[0377]** In some embodiments, epoxy comprising a conductive medium (such as graphene or other carbon nanotubes) may be blended in to the distal tubing (typically formed of plastic) of the ablation catheter shaft and the distal tubing of the ablation catheter itself may function as a thermal transfer. In some embodiments, the addition of the conductive epoxy could increase the thermal conductivity of the distal tubing by 2-3 times or more. These conductive tubing features and other features described in connection with FIG. 20 may be used in connection with the ablation catheters **3120**, **3220** as well.

**[0378]** FIGS. 21A and 21B schematically illustrate a distal portion of an open-irrigated ablation catheter **3420** in perpendicular contact and parallel contact, respectively, with tissue and formation of thermal lesions by delivering energy to the tissue using the ablation catheter **3420**. In accordance with several embodiments, the ablation catheters having multiple temperature-measurement devices described herein advantageously facilitate determination of, among other things: an orientation of the distal tip of the ablation catheter with respect to the tissue, an estimated peak temperature within the thermal lesion, and/or a location of the peak temperature zone within the thermal lesion.

**[0379]** As mentioned above, the temperature-measurement devices **3425** may send or transmit signals to a processing device (for example, processor **46** of FIG. 1). The processing device may be programmed to execute instructions stored on one or more computer-readable storage media to determine temperature measurements for each of the temperature-measurement devices **3425** and to compare the determined temperature measurements with each other to determine an orientation of the distal tip of the ablation catheter with respect to the tissue based, at least in part, on the comparison. The processing device may select an orientation from one of parallel, perpendicular, or angled (for example, skewed or oblique) orientations.

**[0380]** For example, if the temperature measurements received from the distal temperature-measurement devices are all greater (for example, hotter) than the temperature measurements received from the proximal temperature-measurement devices, then the processor may determine that the orientation is perpendicular. If the temperature measurements received from at least one proximal temperature-measurement device and at least one corresponding distal temperature-measurement device are similar, then the processor may determine that the orientation is parallel.

**[0381]** As other examples, for embodiments using three temperature-measurement devices, if two of three proximal temperature-measurement devices generate much lower (and generally equal) temperature measurements than the third proximal-temperature measurement device, then the processing device may determine that the orientation is parallel. For embodiments using three temperature-measurement devices, if the temperature measurements received from a first proximal temperature-measurement device are appreciably greater than temperature measurements from a second proximal temperature-measurement device and if the temperature measurements received from the second proximal

temperature-measurement device are appreciably greater than temperature measurements received from a third proximal temperature-measurement device, then the processing device may determine that the orientation is neither parallel nor perpendicular but skewed at an angle. In some embodiments, orientation may be confirmed using fluoroscopic imaging, ICE imaging or other imaging methods or techniques.

**[0382]** In some embodiments, the determined orientation may be output on a display (for example, a graphical user interface) for visibility by a user. The output may comprise one or more graphical images indicative of an orientation or alphanumeric information indicative of the orientation (for example, a letter, word, phrase or number). The processing device may apply correction factors to the temperature measurements received from the temperature-measurement devices based on the determined orientation in order to generate more accurate estimates of a peak temperature of the thermal lesion. For example, if a perpendicular orientation is determined, then a correction factor or function corresponding to the distal temperature-measurement devices may be applied to determine the estimated peak temperature.

**[0383]** The processing device may comprise a temperature acquisition module and a temperature processing module, in some embodiments. The temperature acquisition module may be configured to receive as input temperature signals (for example, analog signals) generated by each of the temperature-measurement devices. The input signals may be continuously received at prescribed time periods. The temperature acquisition module may be configured to convert analog signals into digital signals. The temperature processing module may receive the digital signals output from the temperature acquisition module and apply correction factors or functions to them to estimate a hottest tissue temperature, a peak temperature or a peak temperature in a thermal lesion created in the vicinity of the electrode or other energy delivery member(s). The temperature processing module may compute a composite temperature from the temperature-measurement devices (for example, thermocouples) based on the following equation:

$$T_{\text{comp}}(t) = k(t) * f(TC1(t), TC2(t), \dots, TCn(t));$$

**[0384]** where  $T_{\text{comp}}$  is the composite temperature,  $k$  is the  $k$  function or correction or adjustment function,  $f$  is a function of the thermocouple readings  $TC_i$ ,  $i=1$  to  $n$ . The  $k$  function may comprise a function over time or a constant value. For example, a  $k$  function may be defined as follows:

$$k(t) = e^{-(t/\tau)} + k_{\text{final}} * (1 - e^{-(t/\tau)});$$

**[0385]** where  $\tau$  is a time constant representative of the tissue time constant and  $k_{\text{final}}$  is a final value of  $k$ , as per a correction factor or function, such as described in connection with FIG. 22A below.

**[0386]** The temperature processing module may also be configured to determine an orientation of a distal tip of a medical instrument with respect to tissue, as described above. The processing device may further comprise an output module and a feedback/monitoring module. The output module may be configured to generate output for display on a display, such as the various outputs described herein. The feedback/monitoring modules may be configured to compare measured temperature values against a predetermined setpoint temperature or maximum temperature and to initiate action (for example, an alert to cause a

user to adjust power or other ablation parameters or automatic reduction in power level or termination of energy delivery (which may be temporary until the temperature decreases below the setpoint temperature). In various embodiments, the setpoint, or maximum, temperature is between 50 and 90 degrees Celsius (for example, 50, 55, 60, 65, 70, 75, 80, 85 degrees Celsius).

**[0387]** In accordance with several embodiments, there is a proportional relationship between the temperature gradient determined by the temperature-measurement devices and the peak temperature of the lesion. From this relationship, a function or correction factor is generated or applied based on numerical modeling (for example, finite element method modeling techniques) and/or measurements stored in a look-up table to adjust or correct from the thermal gradient identified by the temperature-measurement devices to determine the peak temperature. The thermal gradient of an open-irrigated lesion is such that the lesion surface is a little bit cooled and the peak temperature zone is deeper. The further the temperature-measurement devices can be buried into tissue, the better or more accurate the proportional relationship may be between the thermal gradient determined by the temperature-measurement devices and the peak temperature. For example, the thermal gradient can be estimated as:

$$\Delta T/\Delta d = (T_{\text{distal}} - T_{\text{proximal}})/TC_{\text{separation distance}}$$

In other words, the temperature spatial gradient is estimated as the difference in temperature between the distal and proximal temperature-measurement devices divided by the distance between the distal and proximal temperature-measurement devices. The peak tissue temperature (where peak can be a hill or a valley) can then be estimated as:

$$T_{\text{peak}} = \Delta T/\Delta d * T_{\text{peak\_dist}} + T_{\text{distal}}$$

**[0388]** The processing device may also determine an estimated location of the peak temperature zone of the thermal lesion based, at least in part, on the determined orientation and/or the temperature measurements. For example, for a perpendicular orientation, the peak temperature location may be determined to be horizontally centered in the thermal lesion. In some embodiments, the processor may be configured to output information indicative of the peak temperature location on a display (for example, a graphical user interface). The information may include textual information and/or one or more graphical images.

**[0389]** FIG. 22A is a graph illustrating that temperature measurements obtained from the temperature-measurement devices may be used to determine a peak temperature by applying one or more analytical correction factors or functions to the temperature measurements (for example, using numerical modeling approximations or look-up tables). As shown in FIG. 6A, a single correction factor or function (k) may be applied to each of the distal temperature-measurement devices to determine the peak temperature. In some embodiments, different correction factors or functions may be applied to each individual temperature-measurement device or to subsets of the groups of temperature-measurement devices depending on a determined orientation or on a comparison of the temperature measurements obtained by the temperature-measurement devices, thereby providing increased accuracy of peak temperature and peak temperature zone location. The increased accuracy of peak temperature and peak temperature zone location may advantageously result in safer and more reliable ablation procedures

because the ablation parameters may be adjusted based on feedback received by the processing unit from the temperature-measurement devices. In accordance with several embodiments, peak temperatures at a depth beneath the tissue surface are accurately estimated without requiring microwave radiometry. With reference to FIG. 22A, the peak tissue temperature can be estimated as follows:

$$T_{\text{peak}}(t) = e^{(-t^i)} + k * (1 - e^{(-t^i)}) * \max(TC_i(t));$$

**[0390]** where i spans the range of temperature-measurement devices, with  $\max(TC_i(t))$  representing the maximum temperature reading of the temperature-measurement devices at time t. For example, FIG. 22B shows an implementation of the above formula. Trace 1 shows the estimated peak tissue temperature ( $T_{\text{peak}}$ ) at a constant k value of 1.8 and a t value of 1, whereas Traces 2, 3 and 4 show the actual tissue temperatures measured at 1 mm, 3 mm and 5 mm, respectively, from the tissue surface using tissue-embedded infrared probes. As seen, the estimated peak tissue temperature ( $T_{\text{peak}}$ ) of Trace 1 tracks well the actual peak tissue temperature measured at 1 mm depth (Trace 2).

**[0391]** In another embodiment, a predictive model-based approach utilizing the bioheat equation may be utilized to estimate peak tissue temperature. A recursive algorithm for determining the temperature T at a time point n, at a single point in a volume during treatment (for example, RF ablation) may be defined as follows:

$$T_n = \frac{\frac{\rho \cdot C}{dt} \cdot T_{n-1} + W_e \cdot C \cdot T_a + P \cdot N}{\frac{\rho \cdot C}{dt} + W_e \cdot C}$$

where  $T_n$  is the current temperature,  $T_{n-1}$  is the previous temperature, t is time,  $\rho$  is the tissue density, C is the specific heat of tissue,  $T_a$  is the core arterial temperature,  $W_e$  is an effective perfusion rate, and P·N provides an estimate of the volumetric power deposited in tissue. The above equation can be formulated at various spatial locations, including the temperature-measurement device location(s) as well as the location of peak temperature (for example, hot spot). By utilizing this model at different locations, along with calibration to determine the model parameters, mapping techniques can be utilized to predict the temperature at one spatial location using measurement data from the other spatial location.

**[0392]** In some embodiments, the processing device is configured to output the peak temperature or other output indicative of the peak temperature on a display (for example, a graphical user interface). The output may comprise alphanumeric information (for example, the temperature in degrees), one or more graphical images, and/or a color indication. In some embodiments, the processor may generate an output configured to terminate energy delivery if the determined peak temperature is above a threshold or maximum temperature. The output may comprise a signal configured to cause automatic termination of energy delivery or may comprise an alert (audible and/or visual) to cause a user to manually terminate energy delivery.

**[0393]** In various embodiments, ablation parameters may be adjusted based on temperature measurements received from the temperature-measurement devices. The ablation parameters may comprise, among other things, duration of

ablation, power modulation, contact force, target or setpoint temperature, a maximum temperature. The processor 46 (FIG. 1) may be configured to send control signals to the energy delivery module 40 based on the temperature measurements (and other measurements or estimations derived or otherwise determined therefrom) received from the temperature-measurement devices.

[0394] In one embodiment, the energy delivery module 40 (FIG. 1) may be set to run in a temperature control mode, wherein radiofrequency energy of a certain power level is delivered and a maximum temperature is identified which cannot be exceeded. Each of the temperature-measurement devices may be monitored (either simultaneously or via toggled queries) on a periodic or continuous basis. If the maximum temperature is reached or exceeded, as determined by temperature measurements received from any of the temperature-measurement devices of the ablation catheters described herein, control signals may be sent to the energy delivery module to adjust ablation parameters (for example, reduction in power level) to reduce the temperature or to terminate energy delivery (temporarily or otherwise) until the temperature is reduced below the maximum temperature. The adjustments may be effected for example by a proportional-integral-derivative controller (PID controller) of the energy delivery module 40. In another embodiment, the energy delivery module 40 may be set to run in a power control mode, in which a certain level of power is applied continuously and the temperature measurements received from each of the temperature-measurement devices are monitored to make sure a maximum temperature is not exceeded. In some embodiments, a temperature-controlled mode comprises specifying a setpoint temperature (for example, 70 degrees Celsius, 75 degrees Celsius, 80 degrees Celsius, and then adjusting power or other parameters to maintain temperature at, below or near the setpoint temperature, as determined from the temperature measurements received from each of the temperature-measurement devices.

[0395] Table 1 below shows examples of ablation parameters used in various test ablation procedures using an embodiment of an ablation catheter described herein.

TABLE 1

Orientation	Blood flow (cm/s)	Irrigation (ml/min)	Power (W)	Max Tissue			
				Temp (° C.)	Lesion width (mm)	Lesion depth (mm)	Impedance (Ohms)
Parallel	0.5	15	13.3	91.7	9.8	5.2	85
Parallel	25	15	15.8	94.9	9.2	5.4	85
Parallel	0.5	0	8.6	98.8	11.2	4.7	85
Parallel	25	0	14.9	94.8	10.0	5.3	85
Perpend.	0.5	15	16.8	99.4	11	5.6	83
Perpend.	25	15	18.1	99.9	10.3	5.8	83
Perpend.	0.5	0	10.4	97.9	10.3	4.8	83
Perpend.	25	0	16.9	95.7	9.3	5.3	83

[0396] As can be seen from the data in Table 1, the maximum tissue temperature and lesion sizes remained relatively constant with or without irrigation and/or with or without significant blood flow by modulating the power. The multi-variant or multiple temperature-measurement device system according to embodiments of this invention ensures appropriate tissue ablation under different electrode-tissue orientations. As explained above, the electrode-tissue orientation can be determined based on readings from the mul-

multiple temperature-measurement devices. If both proximal and distal temperatures become dominant, then the electrode orientation is estimated or indicated to be parallel to tissue. Similarly, when the distal temperatures are dominant, then the electrode orientation is inferred, estimated and/or indicated to be perpendicular to tissue. Combinations of proximal and distal dominant temperatures may provide indications for oblique electrode orientations. FIG. 23A illustrates a plot of temperature data from the multiple temperature-measurement devices (for example, thermocouples) that are indicative of a perpendicular orientation and FIG. 23B illustrates a plot of temperature data from the multiple temperature-measurement devices (for example, thermocouples) that are indicative of an oblique orientation.

#### Contact Sensing

[0397] According to some embodiments, various implementations of electrodes (for example, radiofrequency or RF electrodes) that can be used for high-resolution mapping and radiofrequency ablation are disclosed herein. For example, as discussed in greater detail herein, an ablation or other energy delivery system can comprise a high-resolution, or combination electrode, design, wherein the energy delivery member (for example, radiofrequency electrode, laser electrode, microwave transmitting electrode) comprises two or more separate electrodes or electrode members or portions. As also discussed herein, in some embodiments, such separate electrodes or electrode portions can be advantageously electrically coupled to each other (for example, to collectively create the desired heating or ablation of targeted tissue). In various embodiments, the combination electrode, or split-tip, design may be leveraged to determine whether or not one or more portions of the electrodes or other energy delivery members are in contact with tissue (for example, endocardial tissue) and/or whether or not contacted tissue has been ablated (for example, to determine whether the tissue is viable or not).

[0398] Several embodiments of the invention are particularly advantageous because they include one, several or all

of the following benefits: (i) confirmation of actual tissue contact that is easily ascertainable; (ii) confirmation of contact with ablated vs. unablated (viable) tissue that is easily ascertainable; (iii) low cost, as the invention does not require any specialized sensor; (iv) does not require use of radiometry; (v) provides multiple forms of output or feedback to a user; (vi) provides output to a user without requiring the user to be watching a display; and/or (vii) provides safer and more reliable ablation procedures.

[0399] With reference to FIG. 1, according to some embodiments, the delivery module 40 includes a processor 46 (for example, a processing or control device) that is configured to regulate one or more aspects of the treatment system 10. The delivery module 40 can also comprise a memory unit or other storage device 48 (for example, non-transitory computer readable medium) that can be used to store operational parameters and/or other data related to the operation of the system 10. In some embodiments, the processor 46 comprises or is in communication with a contact sensing and/or a tissue type detection module or subsystem. The contact sensing subsystem or module may be configured to determine whether or not the energy delivery member(s) 30 of the medical instrument 20 are in contact with tissue (for example, contact sufficient to provide effective energy delivery). The tissue type detection module or subsystem may be configured to determine whether the tissue in contact with the one or more energy delivery member(s) 30 has been ablated or otherwise treated. In some embodiments, the system 10 comprises a contact sensing subsystem 50. The contact sensing subsystem 50 may be communicatively coupled to the processor 46 and/or comprises a separate controller or processor and memory or other storage media. The contact sensing subsystem 50 may perform both contact sensing and tissue type determination functions. The contact sensing subsystem 50 may be a discrete, standalone sub-component of the system (as shown schematically in FIG. 1) or may be integrated into the energy delivery module 40 or the medical instrument 20. Additional details regarding a contact sensing subsystem are provided below.

[0400] In some embodiments, the processor 46 is configured to automatically regulate the delivery of energy from the energy generation device 42 to the energy delivery member 30 of the medical instrument 20 based on one or more operational schemes. For example, energy provided to the energy delivery member 30 (and thus, the amount of heat transferred to or from the targeted tissue) can be regulated based on, among other things, the detected temperature of the tissue being treated, whether the tissue is determined to have been ablated, or whether the energy delivery member 30 is determined to be in contact (for example, "sufficient" contact, or contact above a threshold level) with the tissue to be treated.

[0401] With reference to FIG. 24, the distal electrode 30A may be energized using one or more conductors (for example, wires, cables, etc.). For example, in some arrangements, the exterior of an irrigation tube comprises and/or is otherwise coated with one or more electrically conductive materials (for example, copper, other metal, etc.). Thus, the one or more conductors can be placed in contact with such a conductive surface or portion of the irrigation tube to electrically couple the electrode or electrode portion 30A to an energy delivery module (for example, energy delivery module 40 of FIG. 1). However, one or more other devices and/or methods of placing the electrode or electrode portion 30A in electrical communication with an energy delivery module can be used. For example, one or more wires, cables and/or other conductors can directly or indirectly couple to the electrodes, without the use of the irrigation tube. The energy delivery module may be configured to deliver electromagnetic energy at frequencies useful for determining contact (for example, between 5 kHz and 1000 kHz).

[0402] FIG. 24 schematically illustrates one embodiment of a combination, or split-tip, electrode assembly that can be used to perform contact sensing or determination by measuring the bipolar impedance between the separated electrodes or electrode portions 30A, 30B at different frequencies. Resistance values may be determined from voltage and current based on Ohm's Law:  $Voltage = Current * Resistance$ , or  $V = IR$ . Accordingly, resistance equals voltage divided by current. Similarly, if the impedance between the electrodes is complex, the complex voltage and current may be measured and impedance ( $Z$ ) determined by  $V_{complex} = I_{complex} * Z_{complex}$ . In this case, both magnitude and phase information for the impedance can be determined as a function of frequencies. The different frequencies may be applied to the split-tip electrode assembly by an energy delivery module (for example, by energy generation device 42 of energy delivery module 40 of FIG. 1) or a contact sensing subsystem (such as contact sensing subsystem 50 of system 10 of FIG. 1). Because the voltage and current values may be known or measured, the resistance and/or complex impedance values can be determined from the voltage and current values using Ohm's Law. Thus, the impedance values may be calculated based on measured voltage and/or current values in accordance with several embodiments rather than directly obtaining impedance measurements.

[0403] FIG. 25A is a plot showing resistance, or magnitude impedance, values of blood (or a blood/saline combination) and of cardiac tissue across a range of frequencies (5 kHz to 1000 kHz). The impedance values are normalized by dividing the measured impedance magnitude by the maximum impedance magnitude value. As can be seen, the normalized impedance of blood (or a blood/saline combination) does not vary significantly across the entire range of frequencies. However, the normalized impedance of cardiac tissue does vary significantly over the range of frequencies, forming a roughly "s-shaped" curve.

[0404] In one embodiment, resistance or impedance measurements can be obtained at two, three, four, five, six or more than six different discrete frequencies within a certain range of frequencies. In several embodiments, the range of frequencies may span the range of frequencies used to ablate or otherwise heat targeted tissue. For example, resistance or impedance measurements may be obtained at two different frequencies  $f_1$  and  $f_2$  within the range of frequencies, where  $f_2$  is greater than  $f_1$ . Frequency  $f_1$  may also be below the ablation frequency range and  $f_2$  may be above the ablation frequency range. In other embodiments,  $f_1$  and/or  $f_2$  can be in the range of ablation frequencies. In one embodiment,  $f_1$  is 20 kHz and  $f_2$  is 800 kHz. In various embodiments,  $f_1$  is between 10 kHz and 100 kHz and  $f_2$  is between 400 kHz and 1000 kHz. By comparing the impedance magnitude values obtained at the different frequencies, a processing device (for example, a contact sensing subsystem or module coupled to or executable by processor 46 of FIG. 1) can determine whether or not the electrode portion 30A is in contact with tissue (for example, cardiac tissue) upon execution of specific program instructions stored on a non-transitory computer-readable storage medium.

[0405] For example, if the ratio  $r$  of an impedance magnitude value obtained at the higher frequency  $f_2$  to the impedance magnitude value obtained at the lower frequency  $f_1$  is smaller than a predetermined threshold, the processing device may determine that the electrode portion 30A is in contact with cardiac tissue or other target region (for

example, upon execution of specific program instructions stored on a non-transitory computer-readable storage medium). However, if the ratio  $r$  of an impedance magnitude value obtained at the higher frequency  $f_2$  to the impedance magnitude value obtained at the lower frequency  $f_1$  is greater than a predetermined threshold, the processing device may determine that the electrode portion 30A is not in contact with cardiac tissue but instead is in contact with blood or a blood/saline combination. The contact determinations may be represented as follows:

$$\frac{r_{f_2}}{r_{f_1}} < \text{threshold} = \text{CONTACT}$$

$$\frac{r_{f_2}}{r_{f_1}} > \text{threshold} = \text{NO\_CONTACT}$$

**[0406]** In various embodiments, the predetermined threshold has a value between 0.2 and less than 1 (for example, between 0.2 and 0.99, between 0.3 and 0.95, between 0.4 and 0.9, between 0.5 and 0.9 or overlapping ranges thereof).

**[0407]** In various embodiments, resistance or impedance measurements are periodically or continuously obtained at the different frequencies (for example, two, three, four or more different frequencies) by utilizing a source voltage or current waveform that is a multi-tone signal including the frequencies of interest, as shown in FIG. 25B. The multi-tone signal or waveform may be sampled in the time-domain and then transformed to the frequency domain to extract the resistance or impedance at the frequencies of interest, as shown in FIG. 25C. In some embodiments, measurements or determinations indicative of contact may be obtained in the time domain instead of the frequency domain. Signals or waveforms having different frequencies may be used. In accordance with several embodiments, performing the contact sensing operations is designed to have little or no effect on the electrogram (EGM) functionality of the combination, or split-tip, electrode assembly. For example, common mode chokes and DC blocking circuits may be utilized in the path of the impedance measurement circuitry as shown in FIG. 25D. The circuitry may also include a reference resistor  $R$  to limit the maximum current flow to the patient, as well as dual voltage sampling points  $V1$  and  $V2$  to enhance the accuracy of the impedance measurements. Additionally, a low-pass filter circuit (with, for example, a cut-off frequency of 7 kHz) may be utilized in the path of the EGM recording system, as shown in FIG. 4D. In several embodiments, all or portions of the circuitry shown in FIG. 25D are used in a contact sensing subsystem, such as contact sensing subsystem 50 of FIG. 1 or contact sensing subsystem 4650 of FIG. 27. The frequencies used for contact sensing may be at least greater than five times, at least greater than six times, at least greater than seven times, at least greater than eight times, at least greater than nine times, at least greater than ten times the EGM recording or mapping frequencies. The contact sensing subsystem may be controlled by a processing device including, for example, an analog-to-digital converter (ADC) and a microcontroller (MCU). The processing device may be integral with the processing device 46 of FIG. 1 or may be a separate, stand-alone processing device. If a separate processing device is used, the separate processing device may be communicatively coupled to the processing device 46 of FIG. 1.

**[0408]** In various embodiments, resistance or impedance measurements (for example, total impedance or component parts of complex impedance) are periodically or continuously obtained at the different frequencies (for example, two or three different frequencies) by switching between the different frequencies. In accordance with several embodiments, performing the contact sensing operations may be designed to have little or no effect on the electrogram (EGM) functionality of the combination electrode, or split-tip, assembly. Accordingly, switching between the different frequencies may advantageously be synched to zero crossings of an AC signal waveform, as illustrated in FIG. 26A. In some embodiments, if the frequency switching does not occur at zero crossings, artifacts may be induced in the electrograms, thereby degrading the quality of the electrograms. In some embodiments, impedance measurements (for example, bipolar impedance measurements) are obtained at multiple frequencies simultaneously. In other embodiments, impedance measurements are obtained at multiple frequencies sequentially.

**[0409]** In another embodiment, contact sensing or determination is performed by obtaining resistance or impedance measurements across a full range of frequencies from an  $f_{min}$  to an  $f_{max}$  (for example, 5 kHz to 1 MHz, 10 kHz to 100 kHz, 10 kHz to 1 MHz). In such embodiments, the variation in the frequency response, or the impedance measurements over the range of frequencies, is indicative of whether the electrode portion 30A is in contact with tissue (for example, cardiac tissue) or not.

**[0410]** The impedance measurements may be applied to a model. For example, a frequency response function  $r(f)$  may be created and fit to a polynomial or other fitting function. The function may take the form, for example, of:

$$r(f) = a \cdot f^3 + b \cdot f^2 + c \cdot f + d$$

where  $a$ ,  $b$ ,  $c$  and  $d$  are the terms for the polynomial function that match the response of  $r(f)$  to measured data. Thresholds may then be set on the polynomial terms to determine whether or not the electrode is in contact with tissue. For example, a large  $d$  term may indicate a large impedance indicative of tissue contact. Similarly, a large  $c$  term may indicate a large slope in the impedance which is also indicative of tissue contact. The higher-order terms may be utilized to reveal other subtle differences in the impedance response that indicate tissue contact.

**[0411]** In some embodiments, a circuit model such as that shown in FIG. 26B is used to determine the frequency response function  $r(f)$ . The model may comprise resistors and capacitors that predict the response of tissue and the tissue to electrode interfaces. In this approach, the  $R$  and  $C$  values may be determined that best fit the measured data and thresholds may be utilized based on the  $R$  and  $C$  values to determine whether or not the electrode is in contact with tissue. For example a small value of capacitance ( $C2$ ) may indicate a condition of tissue contact, while a large value may indicate no contact. Other circuit configurations are also possible to model the behavior of the electrode impedance as desired and/or required.

**[0412]** In some embodiments, the contact sensing or contact determination assessments are performed prior to initiation of ablative energy delivery and not performed during energy delivery. In this case, switching may be utilized to separate the contact impedance measurement circuitry from the ablative energy, as shown in FIG. 26C. In this imple-

mentation, a switch SW1 is opened to disconnect the split-tip capacitor ( $C_{ST}$ ) and allow measurement of impedance in the higher frequency ranges where  $C_{ST}$  might present a short circuit (or low impedance in parallel with the measurement). At the same time, switches SW2 and SW3 are set to connect to the impedance measurement circuitry, or contact sensing subsystem. As shown in FIG. 26C, the impedance measurement circuit, or contact sensing subsystem, is the same as that shown in FIG. 25D. When ablations are to be performed, SW2 and SW3 connect the tip electrodes to the ablative energy source (for example, RF generator labeled as RF in FIG. 26C) and disconnect the impedance measurement circuit. SW1 is also switched in order to connect the split tip capacitor  $C_{ST}$ , thereby allowing the pair of electrodes to be electrically connected via a low impedance path. In one embodiment, the split-tip capacitor  $C_{ST}$  comprises a 100 nF capacitor that introduces a series impedance lower than about 4 $\Omega$  at 460 kHz, which, according to some arrangements, is a target frequency for radiofrequency ablation. As FIG. 26C also shows, the ablation current path is from both electrodes to a common ground pad. The impedance measurement path is between the two electrodes, although other current paths for the impedance measurement are also possible. In one embodiment, the switch is a relay such as an electromechanical relay. In other embodiments, other types of switches (for example, solid-state, MEMS, etc.) are utilized.

[0413] In some embodiments, the contact sensing or contact determination assessments described above may be performed while ablative energy or power (for example, ablative radiofrequency energy or power) is being delivered because the frequencies being used for contact sensing are outside of the range (either above or below, or both) of the ablation frequency(ies).

[0414] FIG. 27 schematically illustrates a system 4600 comprising a high-resolution, combination electrode, or split-tip, electrode catheter, the system being configured to perform ablation procedures and contact sensing or determination procedures simultaneously. The high resolution (e.g., split-tip) electrode assembly 4615 may comprise two electrodes or two electrode members or portions 4630A, 4630B separated by a gap. A separator is positioned within the gap G, between the electrodes or electrode portions 4630A, 4630B. The split-tip electrode assembly 4615 may comprise any of the features of the split-tip electrode assemblies described above in connection with FIG. 2 and and/or as otherwise disclosed herein. An energy delivery module (not shown, such as energy delivery module 40 of FIG. 1) or other signal source 4605 may be configured to generate, deliver and/or apply signals in an ablative range (for example, radiofrequency energy 200 kHz-800 kHz, and nominally 460 kHz) while a contact sensing subsystem 4650 (such as the contact sensing subsystem shown in FIG. 25D) delivers low-power signal(s) 4607 (such as excitation signals) in a different frequency range (for example, between 5 kHz and 1000 kHz) to be used to perform the contact sensing or determination assessments to a split-tip electrode assembly 4615. The low-power signal(s) 4607 may comprise a multi-tone signal or waveform or separate signals having different frequencies. The contact sensing subsystem 4650 may comprise the elements shown in FIG. 25D, as well as notch filter circuits to block the ablation frequency (for example, a 460 kHz notch filter if a 460 kHz ablation

frequency is used). In this configuration, a filter 4684 is utilized to separate the contact sensing frequencies and the ablation frequency(ies).

[0415] The filter 4684 may comprise, for example, an LC circuit element, or one or more capacitors without an inductor. The elements and values of the components of the filter 4684 may be selected to center the minimum impedance at the center frequency of the ablative frequencies delivered by the energy delivery module to effect ablation of targeted tissue. In some embodiments, the filtering element 4684 comprises a single capacitor that electrically couples the two electrodes or electrode portions 4630A, 4630B when radiofrequency current is applied to the system. In one embodiment, the capacitor comprises a 100 nF capacitor that introduces a series impedance lower than about 4 $\Omega$  at 460 kHz, which, according to some arrangements, is a target frequency for ablation (for example, RF ablation). However, in other embodiments, the capacitance of the capacitor(s) or other band-pass filtering elements that are incorporated into the system can be greater or less than 100 nF, for example, 5 nF to 300 nF, according to the operating ablation frequency, as desired or required. In this case, the contact sensing impedance frequencies would all be below the ablation frequency range; however, in other implementations, at least some of the contact sensing impedance frequencies are within or above the ablation frequency range.

[0416] FIG. 28 illustrates a plot of impedance of an LC circuit element comprising the filter 4684, for example. As shown, the minimum impedance is centered at the center frequency of the ablative RF frequencies (460 kHz as one example) and the impedance is high at the frequencies in the EGM spectrum so as not to affect EGM signals or the contact sensing measurements. Additionally, the contact impedance measurements are performed at frequencies that exist above and/or below the RF frequency (and above the EGM spectrum). For example, two frequencies  $f_1$  and  $f_2$  may be utilized where  $f_1=20$  kHz and  $f_2=800$  kHz. At these frequencies, the LC circuit would have a large impedance in parallel with the electrodes, thereby allowing the impedance to be measured. In one embodiment, the inductor L has an inductance value of 240  $\mu$ H and the capacitor C has a capacitance value of 5 nF. However, in other embodiments, the inductor L can range from 30  $\mu$ H to 1000  $\mu$ H (for example, 30 to 200  $\mu$ H, 200 to 300  $\mu$ H, 250 to 500  $\mu$ H, 300 to 600  $\mu$ H, 400 to 800  $\mu$ H, 500 to 1000  $\mu$ H, or overlapping ranges thereof) and the capacitor C can range from 0.12 nF to 3.3  $\mu$ F (for example, 0.12 to 0.90 nF, 0.50 to 1.50 nF, 1 nF to 3 nF, 3 nF to 10 nF, 5 nF to 100 nF, 100 nF to 1  $\mu$ F, 500 nF to 2  $\mu$ F, 1  $\mu$ F to 3.3  $\mu$ F, or overlapping ranges thereof). In various embodiments,  $f_1$  is between 10 kHz and 100 kHz and  $f_2$  is between 400 kHz and 1000 kHz.

[0417] In accordance with several embodiments, the same hardware and implementation as used for contact sensing may be used to determine tissue type (for example, viable tissue vs. ablated tissue), so as to confirm whether ablation has been successful or not. FIG. 29 is a plot illustrating resistance, or impedance magnitude, values for ablated tissue, viable tissue and blood across a range of frequencies. As can be seen, the resistance of ablated tissue starts at a high resistance value (200 $\Omega$ ) and remains substantially flat or stable, decreasing slightly over the range of frequencies. The resistance of blood starts at a lower resistance (125 $\Omega$ ) and also remains substantially flat or stable, decreasing slightly over the range of frequencies. The resistance of

viable tissue, however, starts at a high resistance value (250 $\Omega$ ) and significantly decreases across the range of frequencies, roughly forming an “s-shaped” curve. The reason for the different resistance responses between ablated and viable tissue is due, at least partially, to the fact that the viable cells (for example, cardiac cells) are surrounded by a membrane that acts as a high-pass capacitor, blocking low-frequency signals and allowing the higher-frequency signals to pass, whereas the cells of the ablated tissue no longer have such membranes as a result of being ablated. The reason for the substantially flat response for blood resistance is that most of the blood is comprised of plasma, which is more or less just electrolytes having low impedance. The red blood cells do provide some variance, because they have similar membranes acting as capacitors as the viable cardiac cells. However, because the red blood cells constitute such a small percentage of the blood composition, the effect of the red blood cells is not substantial.

[0418] Similar to the contact sensing assessments described above, resistance, or impedance magnitude, values may be obtained at two or more frequencies (for example, 20 kHz and 800 kHz) and the values may be compared to each other to determine a ratio. In some embodiments, if the ratio of the impedance magnitude value at the higher frequency  $f_2$  to the impedance magnitude value at the lower frequency  $f_1$  is less than a threshold, then the processing device (for example, processing device 4624, which may execute a tissue type determination module stored in memory) determines that the contacted tissue is viable tissue and if the ratio of the impedance magnitude value at the higher frequency  $f_2$  to the impedance magnitude value at the lower frequency  $f_1$  is greater than a threshold, then the processing device 4624 determines that the contacted tissue is ablated tissue. In various embodiments, the predetermined threshold has a value between 0.5 and 0.8 (for example, 0.50, 0.55, 0.60, 0.65, 0.70, 0.75, 0.80).

[0419] In some embodiments, a combination of impedance magnitude differences and differences in the ratio of impedance magnitudes at frequencies  $f_2$  and  $f_1$  are utilized to determine both contact state (for example, contact vs. in blood) as well as tissue type (for example, viable tissue vs. ablated tissue). In some embodiments, contact state and tissue type determinations are not performed during energy delivery or other treatment procedures. In other embodiments, contact state and/or tissue type determinations are performed during energy delivery or other treatment procedures using filters and/or other signal processing techniques and mechanisms to separate out the different frequency signals.

[0420] In addition to the impedance magnitude, the same hardware and implementation used for contact sensing (for example, contact sensing subsystem 50, 4650) may be utilized to compute the phase of the impedance (for example, complex impedance) across electrode portions. In one embodiment, the phase of the impedance may be added to algorithms for determining different contact states (for example, contact vs. in blood) as well as different tissue states (for example, viable tissue vs. ablated tissue). FIG. 30 shows an example of the phase of the impedance across electrode portions versus frequency for viable tissue, ablated tissue and blood. The phase tends to be larger (closer to 0 degrees) for blood and smaller for viable (unablated) tissue. For ablated tissue the phase may be in between blood and viable tissue. In one embodiment, a negative phase shift at

a single frequency indicates contact with tissue (either viable or ablated). A larger negative phase shift may indicate contact with viable tissue. In one embodiment, a phase of less than  $-10$  degrees at 800 kHz indicates contact with tissue (either viable or ablated). In one embodiment, a phase of less than  $-20.5$  degrees at 800 kHz indicates contact with viable tissue. In other embodiments, the phase at other frequencies or combinations of frequencies are utilized to determine contact state and tissue type. In some embodiments, the impedance magnitude and phase are utilized together as vector quantities, and differences in the vectors for different frequencies are utilized to determine contact state and tissue type.

[0421] In some embodiments, a combination of impedance magnitude differences, differences in the ratio of impedance magnitude values at frequencies  $f_2$  and  $f_1$ , and differences in the phase of the impedance are utilized together to determine both contact state (for example, contact vs. in blood) as well as tissue type (for example, viable tissue vs. ablated tissue). In one embodiment, the determination process 5000 illustrated in FIG. 31 is utilized to determine both contact state as well as tissue type. In this embodiment, an impedance magnitude threshold of 150 $\Omega$  at 20 kHz is utilized to delineate between no contact and tissue contact (with a larger value indicating contact) at block 5005. Once contact is determined at block 5005, the ratio of the impedance magnitude at  $f_2=800$  kHz and  $f_1=20$  kHz is computed at block 5010, with a value of less than 0.6 indicating contact with unablated, or viable, tissue. If the aforementioned ratio is greater than 0.6, then the impedance phase at 800 kHz is utilized at block 5015, and an (absolute) value greater than 20.5 degrees indicates contact with ablated tissue. An (absolute) value of less than 20.5 degrees indicates contact with unablated, or viable, tissue.

[0422] In some embodiments, the contact sensing subsystem 50 or system 10 (for example, a processing device thereof) analyzes the time-domain response to the waveform described in FIG. 25B, or to an equivalent waveform. In accordance with several embodiments, contact sensing or tissue type determinations are based on processing the response to a signal applied to a pair of electrodes or electrode portions (for example electrode pair 4630A, 4630B), the signal either including multiple frequencies or several frequencies applied sequentially. In some embodiments, processing device 4624 may process the response in time domain or frequency domain. For example, given that blood is mostly resistive, with little capacitive characteristics, it is expected that time-domain features such as rise or fall times, lag or lead times, or delays between applied signal 4402 (for example, I in FIG. 25D) and processed response 4404 (for example, V2 in FIG. 25D) will exhibit low values. Conversely, if the electrode pair 4630A, 4630B of FIG. 27 is in contact with tissue, given that tissue exhibits increased capacitive characteristics, it is expected that time-domain features such as rise or fall times, lag or lead times, or delays between applied signal 4402 (for example, I in FIG. 25D) and processed response 4404 (for example, V2 in FIG. 25D) will exhibit higher values. An algorithm that processes parameters such as, but not limited to, rise or fall times, lag or lead times, or delays between applied signal 4402 and processed response 4404 may indicate or declare contact with tissue when the parameters exceed a threshold, or, conversely, it may indicate or declare no contact with tissue when the parameters have values below a threshold. For

example, assuming the signal **4402** is represented by a sinusoidal current of 800 kHz frequency, the algorithm could declare contact with tissue if the response **4404** lags by more than 0.035  $\mu$ s. Conversely, the algorithm could declare lack of tissue contact if the response **4404** lags by less than 0.035  $\mu$ s. Similarly, if the frequency of signal **4402** were 400 kHz, the algorithm may decide:

**[0423]** no tissue contact, when the lag time is less than 0.07  $\mu$ s;

**[0424]** contact with ablated tissue, when the lag time is between 0.07  $\mu$ s and 0.13  $\mu$ s;

**[0425]** contact with viable or unablated tissue, when the lag time is greater than 0.13  $\mu$ s.

The decision thresholds or criteria depend on the waveform of signal **4402**. Thresholds or decision criteria for other types of waveforms may also be derived or determined.

**[0426]** In some embodiments, multiple inputs may be combined by a contact sensing or contact indication module or subsystem executable by a processor (for example, processor of the contact sensing subsystems **50**, **4650**) to create a contact function that may be used to provide an indication of contact vs. no contact, an indication of the amount of contact (for example, qualitative or quantitative indication of the level of contact, contact state or contact force), and/or an indication of tissue type (for example, ablated vs. viable (non-ablated) tissue). For example, a combination of (i) impedance magnitude at a first frequency  $f_1$ , (ii) the ratio of impedance magnitudes at two frequencies  $f_2$  and  $f_1$  (defined as the slope) or the delta, or change, in impedance magnitudes at the two frequencies, and/or (iii) the phase of the complex impedance at the second frequency  $f_2$  are utilized together to create a contact function that is indicative of contact state (for example, tissue contact vs. in blood). Alternatively, instead of slope, a derivative of impedance with respect to frequency may be used.

**[0427]** In one embodiment, a minimum threshold  $|Z|_{min}$  is defined for the impedance magnitude at  $f_1$ , and a maximum threshold  $|Z|_{max}$  is defined for the impedance at  $f_1$ . The impedance magnitude measured by the contact sensing subsystem **50**, **650** at  $f_1$  can be normalized such that the impedance magnitude is 0 if the measured result is equal to  $|Z|_{min}$  or below, and the impedance magnitude is 1 if the measured result is equal to  $|Z|_{max}$  or above. Results in-between  $|Z|_{min}$  and  $|Z|_{max}$  may be linearly mapped to a value between 0 and 1. Similarly, a minimum threshold  $S_{min}$  and a maximum threshold  $S_{max}$  may be defined for the slope (ratio of impedance magnitude between  $f_2$  and  $f_1$ ). If a derivative of impedance with respect to frequency is used, then similar minimum and maximum thresholds may be defined. The slope measured by the contact sensing subsystem **50** may be normalized such that the slope is 0 if the measured result is equal to or above  $S_{min}$  and the slope is 1 if the measured result is equal to or below  $S_{max}$ . Results in-between  $S_{min}$  and  $S_{max}$  may be linearly mapped to a value between 0 and 1. A minimum threshold  $P_{min}$  and a maximum threshold  $P_{max}$  may also be defined for the phase of the complex impedance at  $f_2$ . The phase measured by the contact sensing subsystem **50** at  $f_2$  may be normalized such that the phase is 0 if the measured result is equal to or greater than  $P_{min}$  and 1 if the measured result is equal to or less than  $P_{max}$ .

**[0428]** In accordance with several embodiments, the resulting three normalized terms for magnitude, slope and phase are combined utilizing a weighting factor for each.

The sum of the weighting factors may be equal to 1 such that the resulting addition of the three terms is a contact indicator that goes from a zero to 1 scale. The weighted contact function (CF) can thus be described by the below equation:

$$CF = WF1 \frac{|Z|_{f1} - |Z|_{min}}{|Z|_{max} - |Z|_{min}} + WF2 \frac{S - S_{min}}{S_{max} - S_{min}} + WF3 \frac{P_{f2} - P_{min}}{P_{max} - P_{min}}$$

**[0429]** where  $|Z|_{f1}$  is the measured impedance magnitude at a first frequency  $f_1$ , clipped to a minimum value of  $|Z|_{min}$  and a maximum value of  $|Z|_{max}$  as described above; S is the ratio of the impedance magnitude at a second frequency  $f_2$  to the magnitude at  $f_1$ , clipped to a minimum value of  $S_{min}$  and a maximum value of  $S_{max}$  as described above; and  $P_{f2}$  is the phase of the impedance at frequency  $f_2$ , clipped to a minimum value of  $P_{min}$  and a maximum value of  $P_{max}$  as described above. The weighting factors WF1, WF2 and WF3 may be applied to the magnitude, slope and phase measurements, respectively. As previously stated, the weighting factors WF1+WF2+WF3 may sum to 1, such that the output of the contact function always provides a value ranging from 0 to 1. Alternatively, values greater than 1 may be allowed to facilitate generation of alerts to a user about circumstances when more tissue-electrode contact may become unsafe for patients. Such alerts may be helpful in preventing application of unsafe levels of contact force. For example, CF values in the range of 1 to 1.25 may be flagged as a "contact alert" and may cause the contact sensing subsystem to generate an alert for display or other output to a user. The alert may be visual, tactile, and/or audible. The weighting factors may vary based on catheter design, connection cables, physical patient parameters, and/or the like. The weighting factors may be stored in memory and may be adjusted or modified (for example, offset) depending on various parameters. In some embodiments, the weighting factors may be adjusted based on initial impedance measurements and/or patient parameter measurements.

**[0430]** The contact function described above can be optimized (for example, enhanced or improved) to provide a reliable indicator of the amount of contact with tissue (for example, cardiac tissue, such as atrial tissue or ventricular tissue). The optimization may be achieved by defining minimum thresholds  $Z_{min}$ ,  $S_{min}$  and  $P_{min}$  that correspond with no to minimal tissue contact, as well as thresholds  $Z_{max}$ ,  $S_{max}$  and  $P_{max}$  that correspond with maximal tissue contact. Weighting terms may also be optimized (for example, enhanced or improved) for robust responsiveness to contact. In some embodiments, windowed averaging or other smoothing techniques may be applied to the contact function to reduce measurement noise.

**[0431]** As one example, at a frequency  $f_1=46$  kHz and  $f_2=800$  kHz, the values  $Z_{min}=115$  ohms,  $Z_{max}=175$  ohms,  $S_{min}=0.9$ ,  $S_{max}=0.8$ ,  $P_{min}=-5.1$  degrees,  $P_{max}=-9$  degrees, WF1=0.75, WF2=0.15, and WF3=0.1 are desirable (for example, optimal) for representing the amount of tissue contact (for example, for cardiac tissue of the atria or ventricles). In other embodiments,  $Z_{min}$  may range from 90 ohms to 140 ohms (for example, 90 ohms to 100 ohms, 95 ohms to 115 ohms, 100 ohms to 120 ohms, 110 ohms to 130 ohms, 115 ohms to 130 ohms, 130 ohms to 140 ohms, overlapping ranges thereof, or any value between 90 ohms and 140 ohms),  $Z_{max}$  may range from 150 ohms up to 320 ohms (for example, 150 ohms to 180 ohms, 160 ohms to 195

ohms, 180 ohms to 240 ohms, 200 ohms to 250 ohms, 225 ohms to 260 ohms, 240 ohms to 300 ohms, 250 ohms to 280 ohms, 270 ohms to 320 ohms, overlapping ranges thereof, or any value between 150 ohms and 320 ohms),  $S_{min}$  may range from 0.95 to 0.80 (for example, 0.95 to 0.90, 0.90 to 0.85, 0.85 to 0.80, overlapping ranges thereof, or any value between 0.95 and 0.80),  $S_{max}$  may range from 0.85 to 0.45 (for example, 0.85 to 0.75, 0.80 to 0.70, 0.75 to 0.65, 0.70 to 0.60, 0.65 to 0.55, 0.60 to 0.50, 0.55 to 0.45, overlapping ranges thereof, or any value between 0.85 and 0.45),  $P_{min}$  may range from 0 to -10 degrees (for example, 0, -1, -2, -3, -4, -5, -6, -7, -8, -9, -10 or any combinations of ranges between, such as 0 to -5, -2 to -6, -4 to -8, -5 to -10), and  $P_{max}$  may range from -5 to -25 degrees (for example, -5 to -10, -7.5 to -15, -10 to -20, -15 to -25, overlapping ranges thereof or any value between -5 and -25 degrees). The weighting factors WF1, WF2 and WF3 may cover the range from 0 to 1. In some embodiments, values above or below the ranges provided may be used as desired and/or required. Appropriate values for these parameters may be dependent on the electrode geometry and frequencies  $f_1$  and  $f_2$  used for the measurements. Changes in the electrode geometry, physical patient parameters, connection cables, and frequencies may require different ranges for the above values.

**[0432]** In some embodiments, a contact function, or contact criterion, can be determined based, at least in part, on an if-then case conditional criterion. One example if-then case criterion is reproduced here:

CC=IF( $|Z_{MAG}| > Z_{THR1}$ , Best, IF(AND( $Z_{THR1} > |Z_{MAG}|$ ,  $|Z_{MAG}| > Z_{THR2}$ ), Good, IF(AND( $Z_{THR2} > |Z_{MAG}|$ ,  $|Z_{MAG}| \geq Z_{THR3}$ ), Medium, IF(AND( $Z_{THR3} > |Z_{MAG}|$ ,  $|Z_{MAG}| \geq Z_{THR4}$ ), Low, No\_Contact))))+IF( $|Z_{MAG}| > Z_{THR1}$ , 0, IF(AND(SLOPE  $\leq S_{THR1}$ ), Good, IF(AND( $S_{THR1} < SLOPE$ ,  $SLOPE \leq S_{THR2}$ ), Medium, IF(AND( $S_{THR2} < SLOPE$ ,  $SLOPE \leq S_{THR3}$ ), Low, No\_Contact))))+IF( $|Z_{MAG}| > Z_{THR1}$ , 0, IF(AND(PHASE  $\leq P_{THR1}$ ), Good, IF(AND( $P_{THR1} < PHASE$ ,  $PHASE \leq P_{THR2}$ ), Medium, IF(AND( $P_{THR2} < PHASE$ ,  $PHASE \leq P_{THR3}$ ), Low, No\_Contact))))

**[0433]** FIG. 32 illustrates an embodiment of a contact criterion process 5100 corresponding to the above if-then case conditional criterion. The contact criterion process 5100 may be executed by a processor upon execution of instructions stored in memory or a non-transitory computer-readable storage medium. At decision block 5105, a measured or calculated impedance magnitude value (for example, based on direct impedance measurements or based on voltage and/or current measurements obtained by a combination electrode assembly comprising two electrode portions) is compared to a predetermined threshold impedance. If the measured or calculated impedance magnitude value  $|Z_{MAG}|$  is greater than a first threshold  $Z_{THR1}$  (for example, 350Ω), then the Contact Criterion (CC) is assigned a “best” or highest value. If, however, the measured or calculated impedance magnitude value  $|Z_{MAG}|$  is less than the threshold  $Z_{THR1}$ , then the process 5100 proceeds to block 5110, where individual subvalues for impedance magnitude, slope and phase are determined. At block 5115, the individual subvalues are combined (for example summed) into an overall value indicative of contact state. In some embodiments, the combination is a sum of a weighted combination, as described above.

**[0434]** The process 5100 may optionally generate output at block 5120. For example, if at decision block 5105, the

measured or calculated impedance magnitude value  $|Z_{MAG}|$  is greater than the first threshold  $Z_{THR1}$ , the process can generate an alert to a user that further manipulation of the catheter or other medical instrument may not further improve tissue contact, but may instead compromise patient safety. For example, if the user pushes too hard on the catheter or other medical instrument, the additional pressure may achieve little improvement in tissue contact but may increase the risk of tissue perforation (for example, heart wall perforation). The output may comprise a qualitative or quantitative output as described in further detail herein (for example in connection with FIG. 33).

**[0435]** FIG. 32A illustrates an embodiment of the individual subvalue subprocess 5110 of process 5100 performed when the measured or calculated impedance magnitude value  $|Z_{MAG}|$  is less than the first threshold  $Z_{THR1}$ . The Contact Criterion (CC) overall value may be calculated by bracketing the impedance magnitude ( $|Z_{MAG}|$ ), the slope (S) and the phase (P) into intervals corresponding to good, medium, low and no contact levels. Subvalues corresponding to either good, medium, low or not contact are determined for each of the impedance magnitude, slope and phase components depending on comparisons to various predetermined threshold values. The subvalues may be combined to determine an overall contact state value. In the example case conditional criterion above, the CC is a sum of the individual values received by each of the three parameters ( $|Z_{MAG}|$ , S, P) according to their corresponding level of contact (for example, good, medium, low or no contact). For example, if Good=3, Medium=2, Low=1 and No\_Contact=0 then the overall CC could be between 0-2 for no or low contact, between 3-4 for poor contact, between 5-6 for medium contact and 7-9 for good contact. In one embodiment, when  $|Z_{MAG}|$  exceeds the first threshold  $Z_{THR1}$ , then CC=10, as an indication that a “best,” or “optimal” level of tissue contact was achieved.

**[0436]** In some embodiments, more than two frequencies are used (for example, three or four frequencies) for tissue contact or tissue type detection. Although the computations described above were presented using impedance magnitude, slope and phase, other characteristics of the complex impedance may be used in other embodiments. For example, analyses of the real and imaginary components of impedance may be used. Analyses of admittance parameters or scattering parameters may also be used. In some embodiments, direct analyses of the voltages and currents described in FIGS. 25A-27 (for example, processing of voltage or current magnitudes, frequency changes or relative phase) may be used. Analyses of voltages or currents may be performed in time domain or frequency domain. Impedance measurements, or values, may be calculated based on voltage and current measurements or may be directly measured. For example, phase measurements may comprise a difference in phase between measured voltage and measured current or may be actual impedance phase measurements.

**[0437]** In some embodiments, the contact indicator or contact function is associated with output via an input/output interface or device. The output may be presented for display on a graphical user interface or display device communicatively coupled to the contact sensing subsystem 50 (FIG. 1). The output may be qualitative (for example, comparative level of contact as represented by a color, scale or gauge)

and/or quantitative (for example, represented by graphs, scrolling waveforms or numerical values) as shown in FIG. 33.

[0438] FIG. 33 illustrates an embodiment of a screen display 5200 of a graphical user interface of a display device communicatively coupled to the contact sensing subsystem 50 (FIG. 1). The screen display 5200 includes a graph or waveform 5210 illustrating impedance magnitude at frequency  $f_1$  over time, as well as a box 5211 indicating the real-time numerical value of the impedance magnitude. The screen display 5200 also includes a graph or waveform 5220 of slope (from  $f_2$  to  $f_1$ ) over time, as well as a box 5221 indicating the real-time numerical value of the slope. The screen display 5200 further includes a graph or waveform 5230 illustrating phase at frequency  $f_2$  over time, as well as a box 5231 indicating the real-time numerical value of the phase. The three measurements (magnitude, slope and phase) are combined into a contact function as described above and may be represented as a contact function or indicator over time, as displayed on graph or waveform 5240. The real-time or instantaneous numerical value of the contact function may also be displayed (Box 5241).

[0439] In some embodiments, as shown in FIG. 33, the contact function or indicator may be represented as a virtual gauge 5250 that provides a qualitative assessment (either alone or in addition to a quantitative assessment) of contact state or level of contact in a manner that is easily discernable by a clinician. The gauge 5250 may be segmented into, for example, four segments, or regions, that represent different classifications or characterizations of contact quality or contact state. For example, a first segment (for example, from contact function values of 0 to 0.25) may be red in color and represent no contact, a second segment (for example, from contact function values of 0.25 to 0.5) may be orange in color and represent “light” contact, a third segment (for example, from contact function values of 0.5 to 0.75) may be yellow in color and represent “medium” or “moderate” contact, and a fourth segment (for example, from contact function values of 0.75 to 1) may be green in color and represent “good”, or “firm”, contact. In other embodiments, fewer than four segments or more than four segments may be used (for example, two segments, three segments, five segments, six segments). In one embodiment, three segments are provided, one segment for no contact or poor contact, one segment for moderate contact and one segment for good, or firm, contact. The segments may be divided equally or otherwise as desired and/or required. Other colors, patterns, graduations and/or other visual indicators may be used as desired. Additionally, a “contact alert” color or gauge graduation may be provided to alert the user about engaging the catheter or other medical instrument with too much force (for example, contact function values greater than 1). The gauge 5250 may include a pointer member that is used to indicate the real-time or instantaneous value of the contact function on the gauge 5250.

[0440] In some embodiments, a qualitative indicator 5260 indicates whether or not contact is sufficient to begin a treatment (for example, ablation) procedure, the level of contact, tissue type, and/or whether contact is greater than desired for safety. The qualitative indicator 5260 may provide a binary indication (for example, sufficient contact vs. insufficient contact, contact or no contact, ablated tissue or viable tissue) or a multi-level qualitative indication, such as that provided by the gauge 5250. In one embodiment, the

qualitative indicator 5260 displays the color on the gauge 5250 corresponding to the current contact function value. Other types of indicators, such as horizontal or vertical bars, other meters, beacons, color-shifting indicators or other types of indicators may also be utilized with the contact function to convey contact quality to the user. Indicators may include one or more light-emitting diodes (LEDs) adapted to be activated upon contact (or a sufficient level of contact) or loss of contact. The LEDs may be different colors, with each color representing a different level of contact (for example, red for no contact, orange for poor contact, yellow for medium contact and green for good contact). The LED(s) may be positioned on the catheter handle, on a display or patient monitor, or any other separate device communicatively coupled to the system.

[0441] In one embodiment involving delivery of radiofrequency energy using a radiofrequency ablation catheter having a plurality of temperature-measurement devices (such as the ablation catheters and temperature-measurement devices described herein), the criterion for detecting a loss of tissue contact during delivery of radiofrequency energy may be implemented as:

$$\Delta T_i / \Delta t < -\text{Threshold1} \quad (\text{Condition 1})$$

or

$$\Delta T_{comp} / \Delta P < \text{Threshold2} \quad (\text{Condition 2})$$

where  $\Delta T_i$  is the change in the temperature of any of the plurality of temperature-measurement devices (for example, sensors, thermocouples, thermistors) positioned along the catheter or other medical instrument;  $\Delta t$  is the interval of time over which the temperature change is measured;  $\Delta T_{comp}$  is the change in the maximum of the temperatures of the temperature-measurement devices and  $\Delta P$  is the change in applied power.

[0442] Condition 1 may signal that the temperature measurements obtained by the temperature-measurement devices have dropped rapidly in a short period of time, which may be indicative of a loss of contact or an insufficient or inadequate level of contact. For example, if  $\Delta T_i$  is  $-10$  degrees Celsius over a  $\Delta t$  of 1 second and Threshold1 is  $-5$  degrees Celsius/second, then the contact loss condition is met (because  $-10$  degrees Celsius/second  $< -5$  degrees Celsius/second).

[0443] Condition 2 may signal that the temperature of the temperature-measurement devices is not increasing even though sufficient power is being applied, which may be indicative of a loss of contact or an insufficient or inadequate level of contact. For example, if  $\Delta T_{comp} = 5$  degrees Celsius and  $\Delta P = 30$  Watts and if Threshold2 is 1 degree Celsius/Watt, then the contact loss condition is met (because  $5$  degrees Celsius/30 Watts  $< 1$  degree Celsius/Watt).

[0444] In accordance with several embodiments, systems and methods for de-embedding, removing, or compensating for the effects caused by variations in cables, generators, wires and/or any other component of an ablation system (and/or components operatively coupled to an ablation system) or by the presence or absence of a catheter interface unit or other hardware component in an energy delivery and mapping system are provided. In some embodiments, the systems and methods disclosed herein advantageously result in contact indication values that are based on network parameter values (for example, impedance values) that more closely represent the actual network parameter value (for

example, impedance) across the electrodes of the high resolution electrode assembly. Accordingly, as a result of the compensation or calibration systems and methods described herein, a clinician may be more confident that the contact indication values are accurate and are not affected by variations in the hardware or equipment being used in or connected to the system or network parameter circuit. In some arrangements, the network parameter values (for example, impedance measurements) obtained by the system using the compensation or calibration embodiments disclosed herein can be within  $\pm 10\%$  (for example, within  $\pm 10\%$ ,  $9\%$ ,  $8\%$ ,  $7\%$ ,  $6\%$ ,  $5\%$ ,  $4\%$ ,  $3\%$ ,  $2\%$ ) of the actual network parameter values (for example, impedance values) across the electrode members of the combination electrode assembly. For example, the impedance magnitude, the impedance slope (ratio of impedance magnitudes at two frequencies) and phase of the impedance may each individually be measured to within  $\pm 10\%$  or better using this approach. As a result, the contact function or contact indicator can advantageously provide an accurate representation of tissue contact, with an accuracy of  $\pm 10\%$  or greater.

[0445] FIG. 34A illustrates a schematic block diagram of an embodiment of a network parameter measurement circuit 5400 (for example, tissue contact impedance measurement circuit). The network parameter measurement circuit 5400 includes a contact sensing signal source 5405, a load 5410 between two electrodes D1, D2 of a high-resolution electrode assembly at a distal end portion of an ablation catheter, and a chain of multiple two-port networks representative of a generator 5415, catheter interface unit cables 5420A, 5420B, a catheter interface unit 5425, a generator cable 5430 and catheter wires 5435. Because in some arrangements the network parameter values (for example, scattering parameter or electrical measurement such as voltage, current or impedance measurements) are obtained at the beginning of the chain at the level of the generator 5415, the measured network parameter values (for example, impedance values obtained directly or from voltage and/or current values) may differ significantly from the actual network parameter values (for example, impedance values) between the two spaced-apart electrode members D1, D2 due to effects of the components of the network parameter circuit between the signal source 5405 and the electrode members D1, D2. The impedance values may comprise impedance magnitude, slope between impedance magnitude at different frequencies, and/or impedance phase values. For example, detected impedance magnitude at a frequency  $f_1$  can be as much as  $\pm 25\%$  different than the actual impedance magnitude at a frequency  $f_1$ . Similarly, a detected slope (ratio of impedance magnitudes at frequencies  $f_2$  and  $f_1$ ) can be as much as  $\pm 50\%$  different than the actual slope. Additionally, the detected phase may be as much as  $\pm 30$  degrees different than the actual phase. As a result of these combined inaccuracies, a contact function (CF) or contact indication values may be as much as  $-100\%$  or  $+150\%$  different than the intended contact function or contact indication values, thereby rendering the contact function ineffective in determining tissue contact. In accordance with several embodiments, the compensation or calibration embodiments disclosed herein can advantageously improve the accuracy of the contact function or contact indication values.

[0446] The network parameters of each of the multi-port (for example, two-port) networks in the network parameter measurement circuit 5400 can be obtained (for example,

measured) and utilized to convert the measured network parameter value (for example, scattering parameter or electrical parameter such as impedance) to a corrected (actual) value (for example, impedance value). In some embodiments, a two-port network analyzer is used to directly measure the scattering parameters (S-parameters) at the input and output of each of the two-port networks. In other embodiments, multiple components of the network parameter measurement circuit 5400 can be combined into groups of components and measured together. The network parameters of the individual components or groups of components can be combined to determine an aggregate effect of the chain of two-port networks on the network parameter value (s). In some implementations, the scattering parameters of at least some of the components may be hard-coded into a software program (for example, using an average value based on a few measurement samples) so as to reduce the number of measurements to be taken or obtained.

[0447] According to one implementation, S-parameter matrices for each of the two-port networks or groups of two-port networks can be transformed to an overall transmission matrix. The overall transmission matrix may then be transformed back into S-parameters (or some other parameters) to generate an S-parameter (or another type of) matrix for the total network. The S-parameters from the total S-parameter matrix can then be used to de-embed, calibrate or compensate for the S-parameters from the measured input reflection coefficient to result in a corrected (actual) reflection coefficient. The actual reflection coefficient may then be converted into a corrected impedance value that is more closely indicative of the actual impedance between the two electrode portions D1, D2 of a high-resolution electrode assembly. In several embodiments, the corrected impedance values are used as the inputs for the Contact Function (CF) or other contact indication or level of contact assessment algorithm or function, as described above. For example, the corrected impedance values can be used to determine the Z, S and P values in the weighted contact function (CF) described above.

[0448] The effects of the hardware components of the network parameter measurement circuit (for example, impedance measurement circuit) 5400 can be compensated for, de-embedded from, or calibrated so as to reduce or remove the effects of the hardware components or differences in the hardware components of a particular system (for example, impedance measurement circuit) setup prior to first use; however, the components of the network parameter circuit may differ across different procedures as different hardware components (for example, generators, cables, catheters and/or the like) are used or as a catheter interface unit or other hardware component to facilitate electroanatomical mapping is plugged in or removed, thereby resulting in inconsistency if not compensated for. In some embodiments, the total system S-parameter matrix may only be updated when the connections within the network parameter measurement circuit 5400 change (for example, when a catheter interface is plugged in or removed from the electrical path, when a cable is switched, etc.).

[0449] In some embodiments, instead of requiring a manual de-embedding of the effects on impedance of certain circuit components when connections change (which can be time-consuming and result in increased likelihood of user error), the network parameters of a subset of the various components (for example, the generator 5415, the catheter

interface unit cables 5420A, 5420B and the catheter interface unit 5425) are automatically measured to enable the effects of these elements to be de-embedded from the network parameters (for example, scattering parameters or impedance measurements) or otherwise compensated for or calibrated. FIG. 34B illustrates an embodiment of a circuit 5450 that can be used to automatically de-embed or compensate for the effects of certain hardware components in the network parameter circuit 5400. In one embodiment, the auto-calibration circuit 5450 is positioned at a distal end of the catheter interface unit cable before the generator cable 5430 and catheter wires 5435. The circuit 5450 may advantageously provide the ability to disconnect the electrode members D1, D2 of the high-resolution electrode assembly from the generator cable 5430 and catheter 5435 and to connect a known load between D1 and D2.

[0450] In this embodiment, the auto-calibration circuit 5450 can assume that the network parameters of the generator cable 5430 and catheter wire 5435 components are known and can be assumed to be constant. However, if the generator cable 5430 and/or catheter wires 5435 are determined to vary significantly from part to part, the circuit 5450 could be implemented at the distal end of the generator cable 5430, in the catheter tip or at any other location, as desired or required. In some embodiments, the known load of the auto-calibration circuit 5450 includes a calibration resistor  $R_{cal}$  and a calibration capacitor  $C_{cal}$ . Switches may be used to connect  $R_{cal}$  as the load,  $C_{cal}$  as the load and both  $R_{cal}$  and  $C_{cal}$  in parallel as the load. Other elements (such as inductors, combinations of resistors, inductors and/or capacitors, or shorts or open circuits can be utilized as the known load). As shown in FIG. 34B, the combined network parameters of the generator 5415, catheter interface unit cables 5420A, 5420B and the catheter interface unit 5425 are represented as a single combined network (Network 1).

[0451] In this embodiment, the network parameters (for example S-parameters) of Network 1 are measured directly using the network parameter circuit and an S-parameter matrix is created from the network parameters. Each of the elements in the S-parameter matrix is a complex number and is frequency dependent. The S-parameters may be measured at multiple different frequencies (for example, 3 different frequencies in the kHz range, such as a first frequency from 5-20 kHz a second frequency from 25-100 kHz and a third frequency from 500-1000 kHz). In one embodiment, the complex impedance is measured with the resistor  $R_{cal}$  connected and the capacitor  $C_{cal}$  disconnected, with the capacitor  $C_{cal}$  connected and the resistor  $R_{cal}$  disconnected and with both the resistor  $R_{cal}$  and the capacitor  $C_{cal}$  connected in parallel. The relationship between the measured complex impedance, the S-parameters of Network 1 and the known load can be expressed as three equations, which can then be used to solve for the S-parameters of Network 1. Once the S-parameters are characterized, they can be combined (for example, using a transmission matrix approach) with the known network parameters of the generator cable 5430 and catheter wires 5435 to provide corrected (actual) impedance measurements at the distal end portion of the catheter (for example, across two spaced-apart electrode portions of a combination electrode assembly).

[0452] The automatic calibration techniques and systems described herein advantageously allow for increased confidence in the contact indication values regardless of the generator, cables, catheter or other equipment being used

and regardless of whether a hardware component to facilitate simultaneous electroanatomical mapping (for example, a catheter interface unit) is connected. The various measurements may be performed automatically upon execution of instructions stored on a computer-readable storage medium executed by a processor or may be performed manually.

[0453] The automatic calibration systems and methods described herein may also be implemented using an equivalent circuit model for one or more hardware components of the system (for example, the generator circuitry, cable and catheter wiring). In such implementations, the equivalent circuit model comprises one or more resistors, one or more capacitors and/or one or more inductors that approximate an actual response of the one or more hardware components being represented. As one example, a generator cable component 5430 can be represented by a transmission-line equivalent RLC model as shown in FIG. 34C, where the measurement of the impedance  $Z_{meas}$  would be performed at Port 1 with the actual (corrected) impedance  $Z_{act}$  desired being at Port 2. In this example, if the impedance measurement circuit is measuring an impedance  $Z_{meas}$ , the actual impedance measurement  $Z_{act}$  can be extracted by using circuit analysis techniques. The equation relating the two impedances is given by:

$$Z_{meas} = R + j\omega L + \frac{Z_{act}}{1 + j\omega C \cdot Z_{act}}$$

[0454] The actual values for R, L and C may be extracted from network parameter measurements. For example if we measure the impedance (Z) parameters of this network, we can derive the following relationships:

$$\begin{aligned} Z_{11} &= \frac{V_1}{I_1} \Big|_{I_2=0} = R + j\omega L + \frac{1}{j\omega C} \\ Z_{21} &= \frac{V_2}{I_1} \Big|_{I_2=0} = \frac{1}{j\omega C} \\ Z_{11} - Z_{21} &= R + j\omega L \end{aligned}$$

[0455] where 1 and 2 denote the port numbers of the circuit, and  $V_1$ ,  $I_1$ ,  $V_2$  and  $I_2$  represent the voltages and currents at each of the respective ports. The values for R, L and C may also be measured utilizing measurement tools (for example, a multimeter). The equivalent circuit model approach described above is an example of this concept. In other implementations, more complex circuit models may be utilized to represent the various elements of the system.

[0456] In some embodiments, the system comprises one or more of the following: means for tissue modulation (for example, an ablation or other type of modulation catheter or delivery device), means for generating energy (for example, a generator or other energy delivery module), means for connecting the means for generating energy to the means for tissue modulation (for example, an interface or input/output connector or other coupling member), means for performing tissue contact sensing and/or tissue type determination, means for displaying output generated by the means for performing tissue contact sensing and/or tissue type determination, means for determining a level of contact with

tissue, means for calibrating network parameter measurements in connection with contact sensing means, etc.

**[0457]** In some embodiments, the system comprises various features that are present as single features (as opposed to multiple features). For example, in one embodiment, the system includes a single ablation catheter with a single high-resolution (e.g., split-tip) electrode and one or more temperature sensors (e.g., thermocouples) to help determine the temperature of tissue at a depth. The system may comprise an impedance transformation network. In some embodiments, the system includes a single ablation catheter with a heat shunt network for the transfer of heat away from the electrode and/or tissue being treated. In some embodiments, the system includes a single contact sensing subsystem for determining whether there is and to what extent there is contact between the electrode and targeted tissue of a subject. Multiple features or components are provided in alternate embodiments.

**[0458]** In one embodiment, the system comprises one or more of the following: means for tissue modulation (e.g., an ablation or other type of modulation catheter or delivery device), means for generating energy (e.g., a generator or other energy delivery module), means for connecting the means for generating energy to the means for tissue modulation (e.g., an interface or input/output connector or other coupling member), etc.

**[0459]** In some embodiments, the system comprises one or more of the following: means for tissue modulation (e.g., an ablation or other type of modulation catheter or delivery device), means for measuring tissue temperature at a depth (e.g., using multiple temperature sensors (e.g., thermocouples) that are thermally insulated from the electrode and that are located along two different longitudinal portions of the catheter), means for effectively transferring heat away from the electrode and/or the tissue being treated (e.g., using heat shunting materials and components) and means for determining whether and to what extent there is contact between the electrode and adjacent tissue (e.g., using impedance measurements obtained from a high-resolution electrode that is also configured to ablate the tissue).

**[0460]** In some embodiments, the system comprises one or more of the following: an ablation system consists essentially of a catheter, an ablation member (e.g., a RF electrode, a split-tip electrode, another type of high-resolution electrode, etc.), an irrigation conduit extending through an interior of the catheter to or near the ablation member, at least one electrical conductor (e.g., wire, cable, etc.) to selectively activate the ablation member and at least one heat transfer member that places at least a portion of the ablation member (e.g., a proximal portion of the ablation member) in thermal communication with the irrigation conduit, at least one heat shunt member configured to effectively transfer heat away from the electrode and/or tissue being treated, a plurality of temperature sensors (e.g., thermocouples) located along two different longitudinal locations of the catheter, wherein the temperature sensors are thermally isolated from the electrode and configured to detect temperature of tissue at a depth, contact detection subsystem for determining whether and to what extent there is contact between the electrode and adjacent tissue (e.g., using impedance measurements obtained from a high-resolution electrode that is also configured to ablate the tissue), etc.

**[0461]** In the embodiments disclosed above, a heat transfer member is disclosed. Alternatively, a heat retention sink is used instead of or in addition to the heat transfer member in some embodiments.

**[0462]** According to some embodiments, an ablation system consists essentially of a catheter, an ablation member (e.g., a RF electrode, a split-tip electrode, another type of high-resolution electrode, etc.), an irrigation conduit extending through an interior of the catheter to or near the ablation member, at least one electrical conductor (e.g., wire, cable, etc.) to selectively activate the ablation member and at least one heat transfer member that places at least a portion of the ablation member (e.g., a proximal portion of the ablation member) in thermal communication with the irrigation conduit, at least one heat shunt member configured to effectively transfer heat away from the electrode and/or tissue being treated and a plurality of temperature sensors (e.g., thermocouples) located along two different longitudinal locations of the catheter, wherein the temperature sensors are thermally isolated from the electrode and configured to detect temperature of tissue at a depth.

**[0463]** Any methods described herein may be embodied in, and partially or fully automated via, software code modules executed by one or more processors or other computing devices. The methods may be executed on the computing devices in response to execution of software instructions or other executable code read from a tangible computer readable medium. A tangible computer readable medium is a data storage device that can store data that is readable by a computer system. Examples of computer readable mediums include read-only memory, random-access memory, other volatile or non-volatile memory devices, CD-ROMs, magnetic tape, flash drives, and optical data storage devices.

**[0464]** In addition, embodiments may be implemented as computer-executable instructions stored in one or more tangible computer storage media. As will be appreciated by a person of ordinary skill in the art, such computer-executable instructions stored in tangible computer storage media define specific functions to be performed by computer hardware such as computer processors. In general, in such an implementation, the computer-executable instructions are loaded into memory accessible by at least one computer processor. The at least one computer processor then executes the instructions, causing computer hardware to perform the specific functions defined by the computer-executable instructions. As will be appreciated by a person of ordinary skill in the art, computer execution of computer-executable instructions is equivalent to the performance of the same functions by electronic hardware that includes hardware circuits that are hardwired to perform the specific functions. As such, while embodiments illustrated herein are typically implemented as some combination of computer hardware and computer-executable instructions, the embodiments illustrated herein could also be implemented as one or more electronic circuits hardwired to perform the specific functions illustrated herein.

**[0465]** The various systems, devices and/or related methods disclosed herein can be used to at least partially ablate and/or otherwise ablate, heat or otherwise thermally treat one or more portions of a subject's anatomy, including without limitation, cardiac tissue (e.g., myocardium, atrial tissue, ventricular tissue, valves, etc.), a bodily lumen (e.g., vein, artery, airway, esophagus or other digestive tract

lumen, urethra and/or other urinary tract vessels or lumens, other lumens, etc.), sphincters, other organs, tumors and/or other growths, nerve tissue and/or any other portion of the anatomy. The selective ablation and/or other heating of such anatomical locations can be used to treat one or more diseases or conditions, including, for example, atrial fibrillation, mitral valve regurgitation, other cardiac diseases, asthma, chronic obstructive pulmonary disease (COPD), other pulmonary or respiratory diseases, including benign or cancerous lung nodules, hypertension, heart failure, denervation, renal failure, obesity, diabetes, gastroesophageal reflux disease (GERD), other gastroenterological disorders, other nerve-related disease, tumors or other growths, pain and/or any other disease, condition or ailment.

**[0466]** In any of the embodiments disclosed herein, one or more components, including a processor, computer-readable medium or other memory, controllers (for example, dials, switches, knobs, etc.), displays (for example, temperature displays, timers, etc.) and/or the like are incorporated into and/or coupled with (for example, reversibly or irreversibly) one or more modules of the generator, the irrigation system (for example, irrigant pump, reservoir, etc.) and/or any other portion of an ablation or other modulation system.

**[0467]** Although several embodiments and examples are disclosed herein, the present application extends beyond the specifically disclosed embodiments to other alternative embodiments and/or uses of the inventions and modifications and equivalents thereof. It is also contemplated that various combinations or subcombinations of the specific features and aspects of the embodiments may be made and still fall within the scope of the inventions. Accordingly, it should be understood that various features and aspects of the disclosed embodiments can be combine with or substituted for one another in order to form varying modes of the disclosed inventions. Thus, it is intended that the scope of the present inventions herein disclosed should not be limited by the particular disclosed embodiments described above, but should be determined only by a fair reading of the claims that follow.

**[0468]** While the embodiments disclosed herein are susceptible to various modifications, and alternative forms, specific examples thereof have been shown in the drawings and are herein described in detail. It should be understood, however, that the inventions are not to be limited to the particular forms or methods disclosed, but, to the contrary, the inventions are to cover all modifications, equivalents, and alternatives falling within the spirit and scope of the various embodiments described and the appended claims. Any methods disclosed herein need not be performed in the order recited. The methods disclosed herein include certain actions taken by a practitioner; however, they can also include any third-party instruction of those actions, either expressly or by implication. For example, actions such as “advancing a catheter” or “delivering energy to an ablation member” include “instructing advancing a catheter” or “instructing delivering energy to an ablation member,” respectively. The ranges disclosed herein also encompass any and all overlap, sub-ranges, and combinations thereof. Language such as “up to,” “at least,” “greater than,” “less than,” “between,” and the like includes the number recited. Numbers preceded by a term such as “about” or “approximately” include the recited numbers. For example, “about 10 mm” includes “10 mm.” Terms or phrases preceded by a

term such as “substantially” include the recited term or phrase. For example, “substantially parallel” includes “parallel.”

1. (canceled)
2. A method of heat removal from an electrode assembly during a tissue treatment procedure, the method comprising: delivering energy to an electrode assembly of an ablation system, the ablation system comprising a catheter comprising a distal end, the electrode assembly positioned along the distal end of the catheter; wherein the catheter of the ablation system comprises at least one thermal shunt member along its distal end, wherein the at least one thermal shunt member extends at least partially through an interior of the electrode assembly; and wherein the catheter further comprises at least one fluid passage extending at least partially through the interior of the electrode assembly and an interior of the at least one thermal shunt member; delivering a fluid through the at least one fluid passage; and transferring heat from the electrode assembly to the fluid via the at least one thermal shunt member to reduce the likelihood of localized hot spots along the distal end of the catheter.
3. The method of claim 2, wherein the at least one thermal shunt member is configured to transfer heat while not retaining heat, and wherein the at least one thermal shunt member comprises a thermal diffusivity greater than 1.5 cm<sup>2</sup>/sec; wherein the electrode assembly comprises at least one radiofrequency electrode; and wherein the at least one fluid passage is configured to place the electrode assembly in fluid communication with a fluid source to selectively remove heat from the electrode assembly and/or tissue of a subject located adjacent the electrode assembly.
4. The method of claim 2, wherein the at least one thermal shunt member is configured to transfer heat while not retaining heat, and wherein the at least one thermal shunt member comprises a thermal diffusivity greater than 1.5 cm<sup>2</sup>/sec.
5. The method of claim 2, wherein the at least one thermal shunt member comprises a diamond or other carbon-based material.
6. The method of claim 2, wherein the electrode assembly comprises a composite electrode, the composite electrode comprising a first electrode portion and at least a second electrode portion, wherein an electrically insulating gap is located between the first electrode portion and the at least a second electrode portion to facilitate high-resolution mapping along a targeted anatomical area
7. The method of claim 2, wherein the at least one fluid passage is configured to place the electrode assembly in fluid communication with a fluid source to selectively remove heat from the electrode assembly and/or tissue of a subject located adjacent the electrode assembly.
8. The method of claim 2, wherein the at least one fluid passage is in direct thermal communication with the at least one thermal shunt member.
9. The method of claim 2, wherein the at least one fluid passage is in indirect thermal communication with the at least one thermal shunt member.

**10.** The method of claim 2, wherein the at least one fluid passage comprises at least one opening, wherein the at least one opening allows fluid flowing through the at least one fluid passage to exit the catheter.

**11.** A method of heat removal from an electrode assembly during a tissue treatment procedure, comprising:

delivering energy to an electrode assembly of an ablation system, the electrode assembly positioned along a distal end of an elongate body;

wherein at least one thermal shunt member extends at least partially through an interior of the electrode assembly; and

wherein the elongate body further comprises at least one fluid passage extending at least partially through the interior of the at least one thermal shunt member;

delivering a fluid through the at least one fluid passage; and

transferring heat from the electrode assembly to the fluid via the at least one thermal shunt member to reduce the likelihood of localized hot spots along the distal end of the elongate body.

**12.** The method of claim 11,

wherein the at least one thermal shunt member is configured to transfer heat while not retaining heat, and wherein the at least one thermal shunt member comprises a thermal diffusivity greater than  $1.5 \text{ cm}^2/\text{sec}$ ; and

wherein the at least one fluid passage is configured to place the electrode assembly in fluid communication with a fluid source to selectively remove heat from the electrode assembly and/or tissue of a subject located adjacent the electrode assembly.

**13.** The method of claim 11, wherein the at least one thermal shunt member is configured to transfer heat while not retaining heat, and wherein the at least one thermal shunt member comprises a thermal diffusivity greater than  $1.5 \text{ cm}^2/\text{sec}$ .

**14.** The method of claim 11, wherein the at least one thermal shunt member comprises a diamond or other carbon-based material.

**15.** The method of claim 11, wherein the electrode assembly comprises a composite electrode, the composite electrode comprising a first electrode portion and at least a second electrode portion, wherein an electrically insulating gap is located between the first electrode portion and the at least a second electrode portion to facilitate high-resolution mapping along a targeted anatomical area.

**16.** The method of claim 11, wherein the at least one fluid passage is in direct thermal communication with the at least one thermal shunt member.

**17.** A method of heat removal from an ablation member during a tissue treatment procedure, comprising:

delivering energy to an ablation member of an ablation system, the ablation member positioned along a distal end of an elongate body;

wherein at least one thermal shunt member extends at least partially through an interior of the ablation member; and

wherein at least one fluid passage extends at least partially through an interior of the at least one thermal shunt member;

delivering a fluid through the at least one fluid passage; and

transferring heat from the electrode assembly to the fluid via the at least one thermal shunt member.

**18.** The method of claim 17,

wherein the at least one thermal shunt member is configured to transfer heat while not retaining heat, and wherein the at least one thermal shunt member comprises a thermal diffusivity greater than  $1.5 \text{ cm}^2/\text{sec}$ ; and

wherein the at least one fluid passage is configured to place the ablation member in fluid communication with a fluid source to selectively remove heat from the ablation member and/or tissue of a subject located adjacent the ablation member.

**19.** The method of claim 17, wherein the at least one thermal shunt member is configured to transfer heat while not retaining heat, and wherein the at least one thermal shunt member comprises a thermal diffusivity greater than  $1.5 \text{ cm}^2/\text{sec}$ .

**20.** The method of claim 17, wherein the at least one thermal shunt member comprises a diamond or other carbon-based material.

**21.** The method of claim 17, wherein the ablation member comprises a composite electrode, the composite electrode comprising a first electrode portion and at least a second electrode portion, wherein an electrically insulating gap is located between the first electrode portion and the at least a second electrode portion to facilitate high-resolution mapping along a targeted anatomical area.

\* \* \* \* \*

专利名称(译)	使用热分流从电极移除热量的方法		
公开(公告)号	<a href="#">US20190029753A1</a>	公开(公告)日	2019-01-31
申请号	US16/147403	申请日	2018-09-28
[标]发明人	SCHULTHEIS ERIC ANDREW KOBlish JOSEF VINCENT PANESCU DORIN		
发明人	SCHULTHEIS, ERIC ANDREW KOBlish, JOSEF VINCENT PANESCU, DORIN		
IPC分类号	A61B18/14 A61B5/042 A61B5/06 A61B5/15 A61B5/00 A61B18/12 A61B5/01 A61B18/00		
CPC分类号	A61B2018/00023 A61B2562/046 A61B2018/128 A61B2018/00577 A61B2018/00357 A61B2218/002 A61B18/1206 A61B5/068 A61B2018/00797 A61B2018/00875 A61B5/6852 A61B2018/00101 A61B2018 /00672 A61B18/1492 A61B2018/00083 A61B2018/00815 A61B2018/0016 A61B2018/00839 A61B2018 /1467 A61B5/0422 A61B5/01 A61B2018/00029 A61B2018/00678 A61B2018/00821 A61B2018/00714 A61B2018/00761 A61B2018/00702 A61B2018/00351 A61B2217/007 A61B5/150954 A61B2018/00642		
优先权	62/081710 2014-11-19 US 62/094892 2014-12-19 US 62/135046 2015-03-18 US 62/135025 2015-03-18 US 62/138338 2015-03-25 US 62/211539 2015-08-28 US		
其他公开文献	US10660701		
外部链接	<a href="#">Espacenet</a> <a href="#">USPTO</a>		

摘要(译)

根据一些实施例，医疗器械（例如，消融装置）包括具有近端和远端的细长主体，定位在细长主体的远端处的能量递送构件，第一多个温度测量由能量输送构件承载或定位在能量输送构件内的装置，第一多个温度测量装置与能量输送构件热绝缘，并且第二多个温度测量装置定位在能量输送构件的近端附近，第二多个温度测量装置与能量输送构件热绝缘。

