



(19) **United States**

(12) **Patent Application Publication**  
**Bahney et al.**

(10) **Pub. No.: US 2018/0289274 A1**

(43) **Pub. Date: Oct. 11, 2018**

(54) **PHYSIOLOGICAL MONITORING DEVICE**

(60) Provisional application No. 61/756,326, filed on Jan. 24, 2013.

(71) Applicant: **iRhythm Technologies, Inc.**, San Francisco, CA (US)

**Publication Classification**

(72) Inventors: **Timothy J. Bahney**, San Francisco, CA (US); **Hung H. Ho**, San Francisco, CA (US); **Shena H. Park**, San Francisco, CA (US); **Genaro S. Sepulveda**, San Francisco, CA (US); **Mark J. Day**, San Francisco, CA (US); **Yuriko Tamura**, Belmont, CA (US)

(51) **Int. Cl.**  
**A61B 5/0408** (2006.01)  
**A61B 5/00** (2006.01)  
(52) **U.S. Cl.**  
CPC ..... **A61B 5/0408** (2013.01); **A61B 2562/164** (2013.01); **A61B 2562/125** (2013.01); **A61B 2562/0219** (2013.01); **A61B 5/721** (2013.01); **A61B 5/6833** (2013.01)

(21) Appl. No.: **16/006,719**

(57) **ABSTRACT**

(22) Filed: **Jun. 12, 2018**

The present invention relates to a physiological monitoring device. Some embodiments of the invention allow for long-term monitoring of physiological signals. Further embodiments may also allow for the monitoring of secondary signals such as motion.

**Related U.S. Application Data**

(63) Continuation of application No. 14/162,656, filed on Jan. 23, 2014, now abandoned.

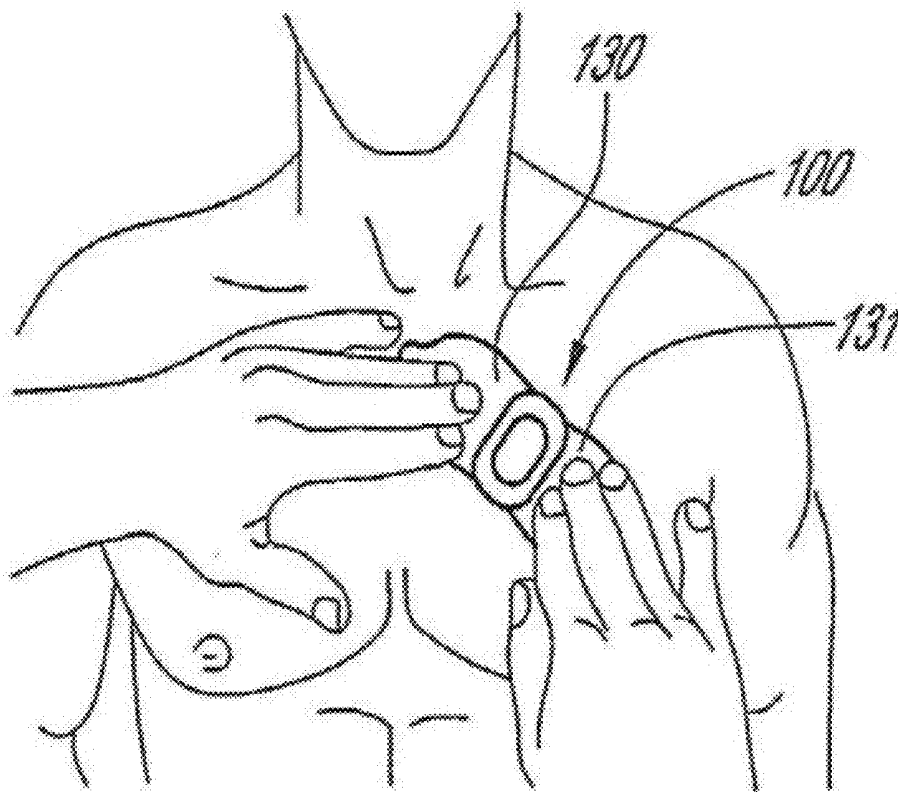

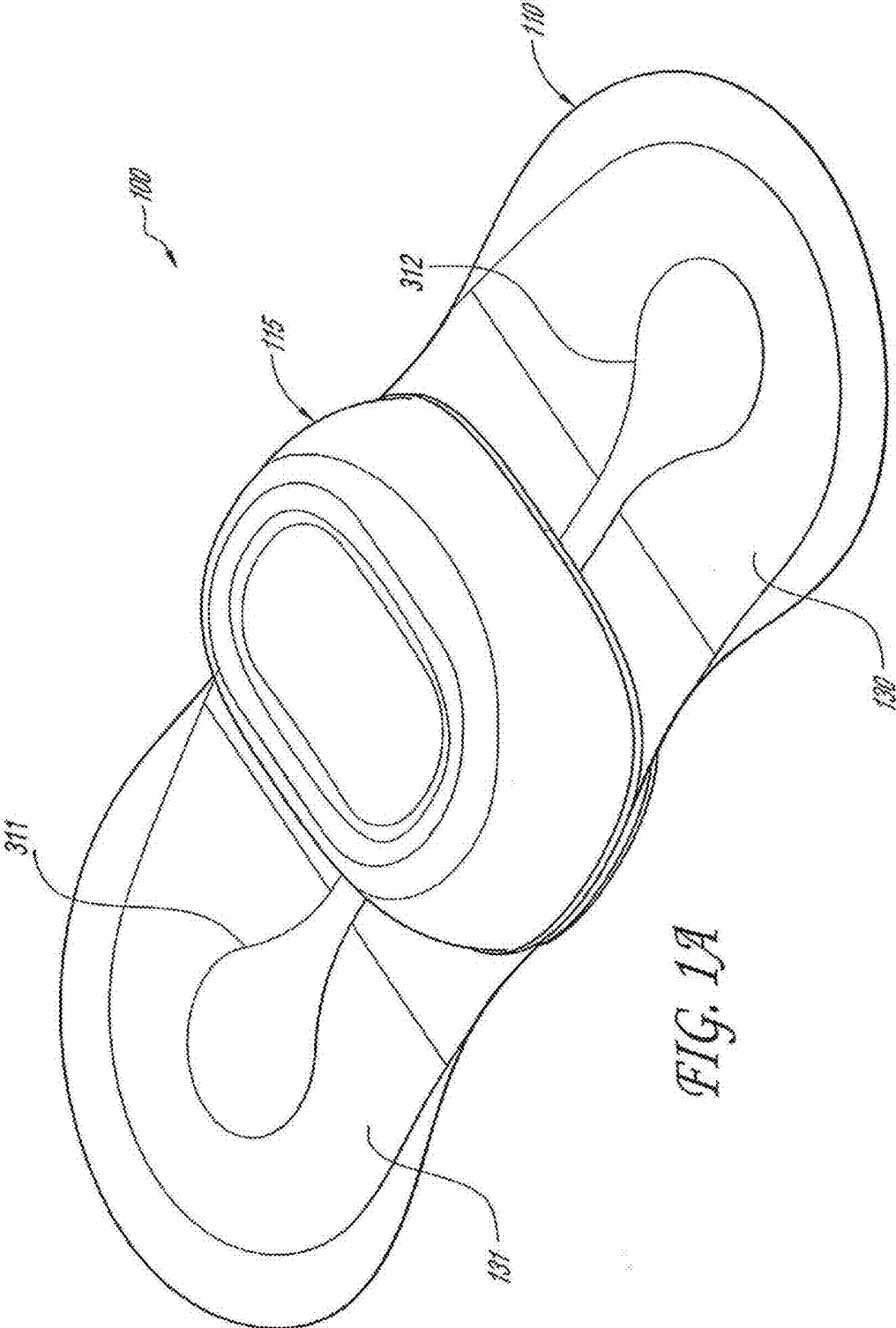

FIG. 1A

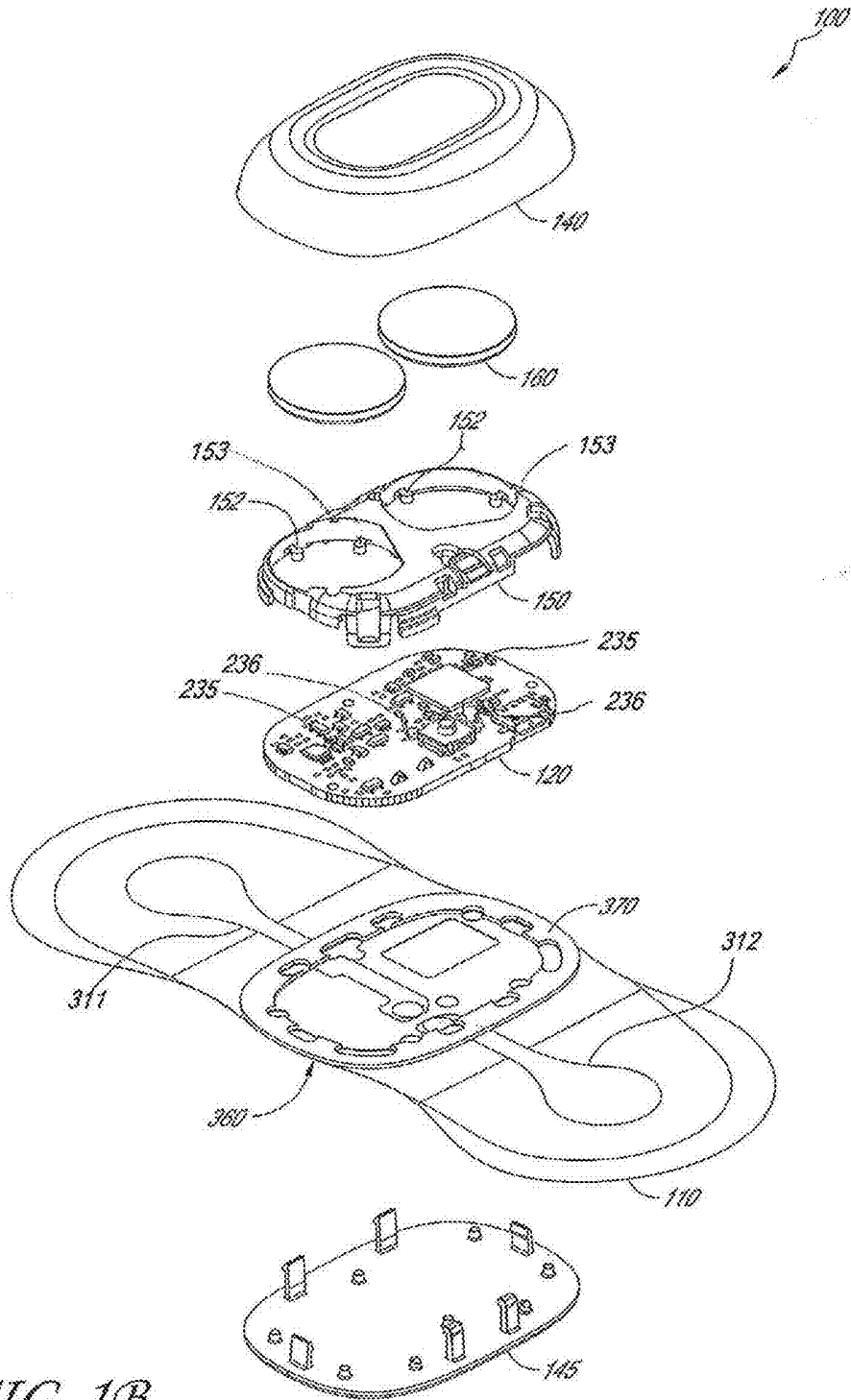

FIG. 1B

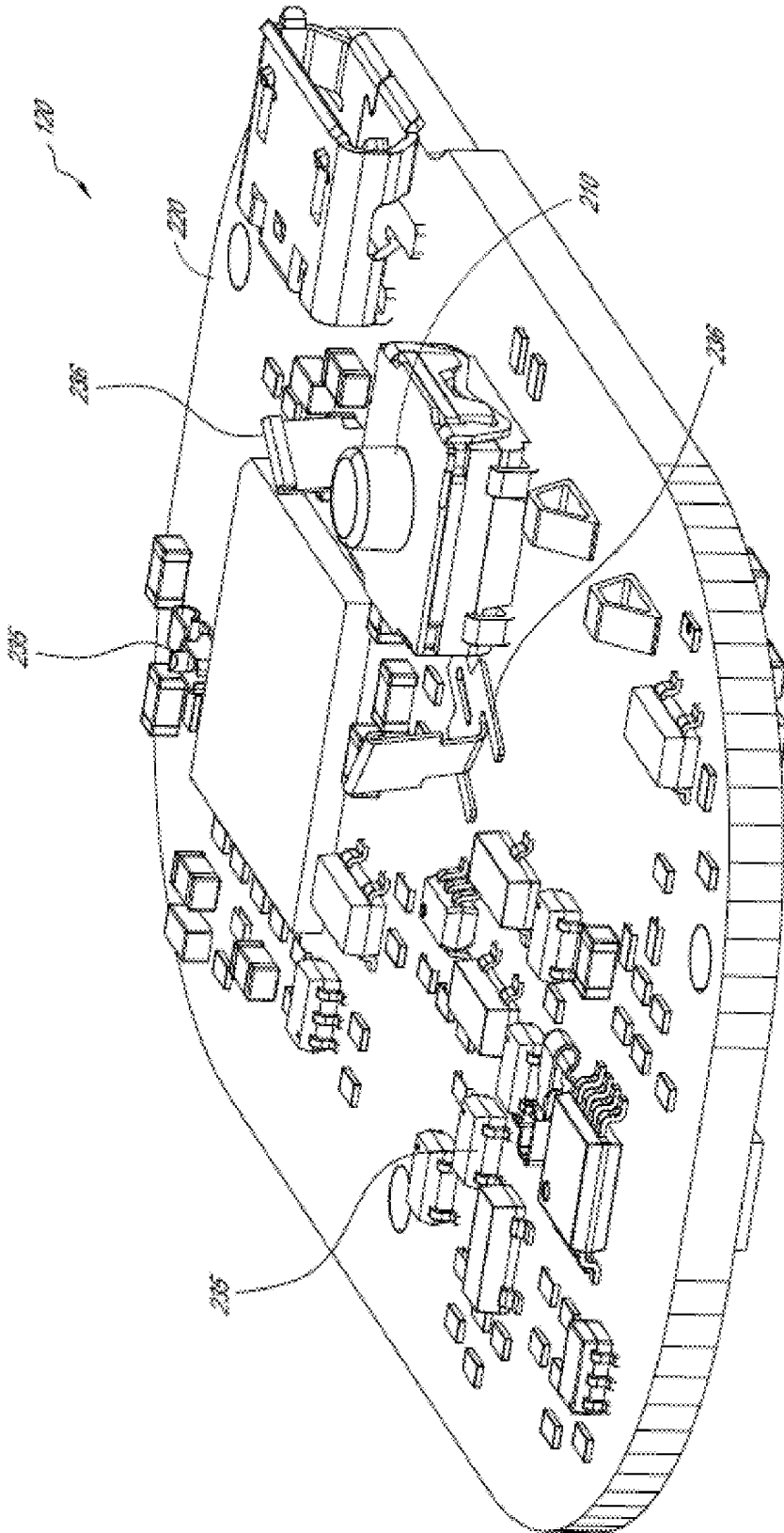

FIG. 2A

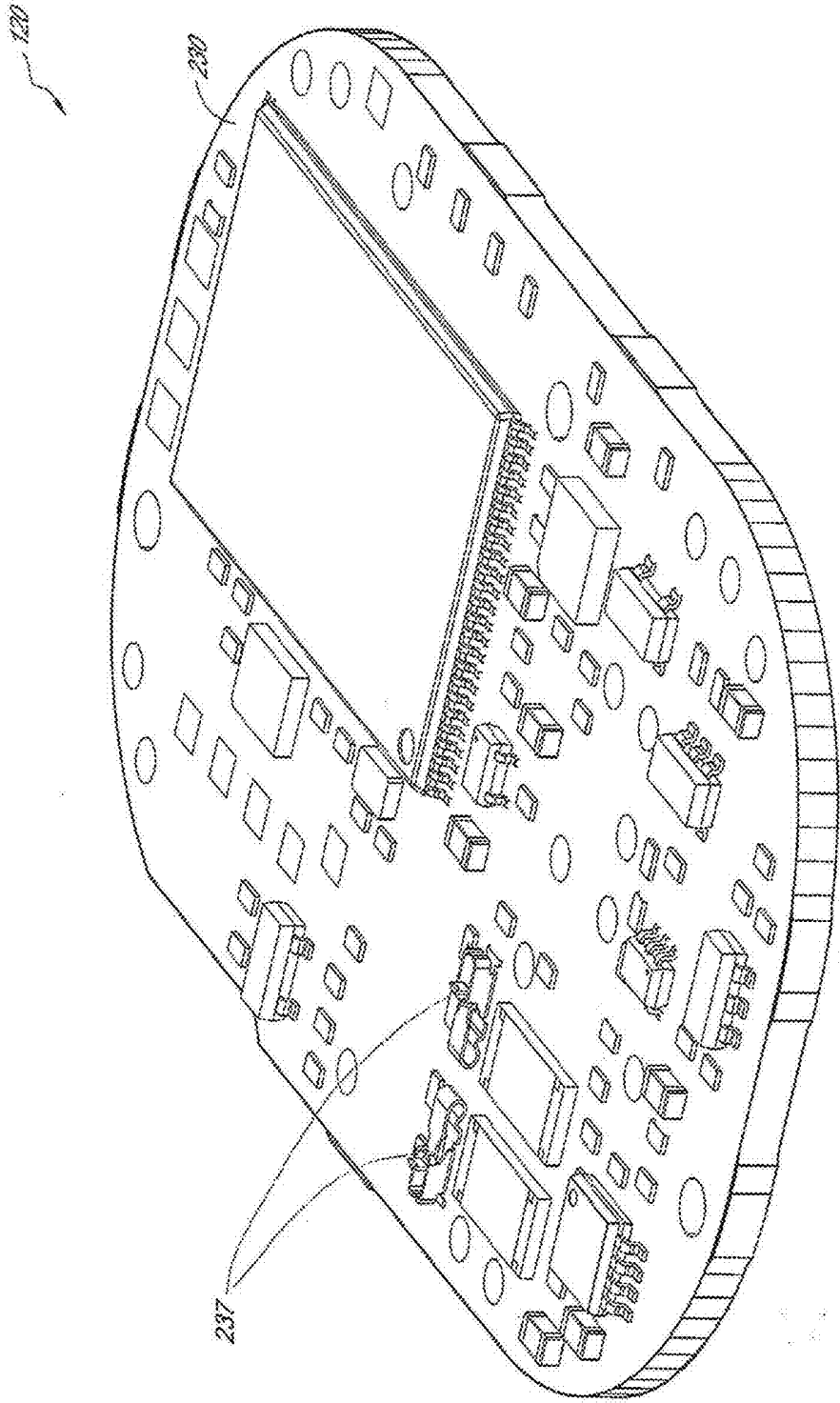

FIG. 2B



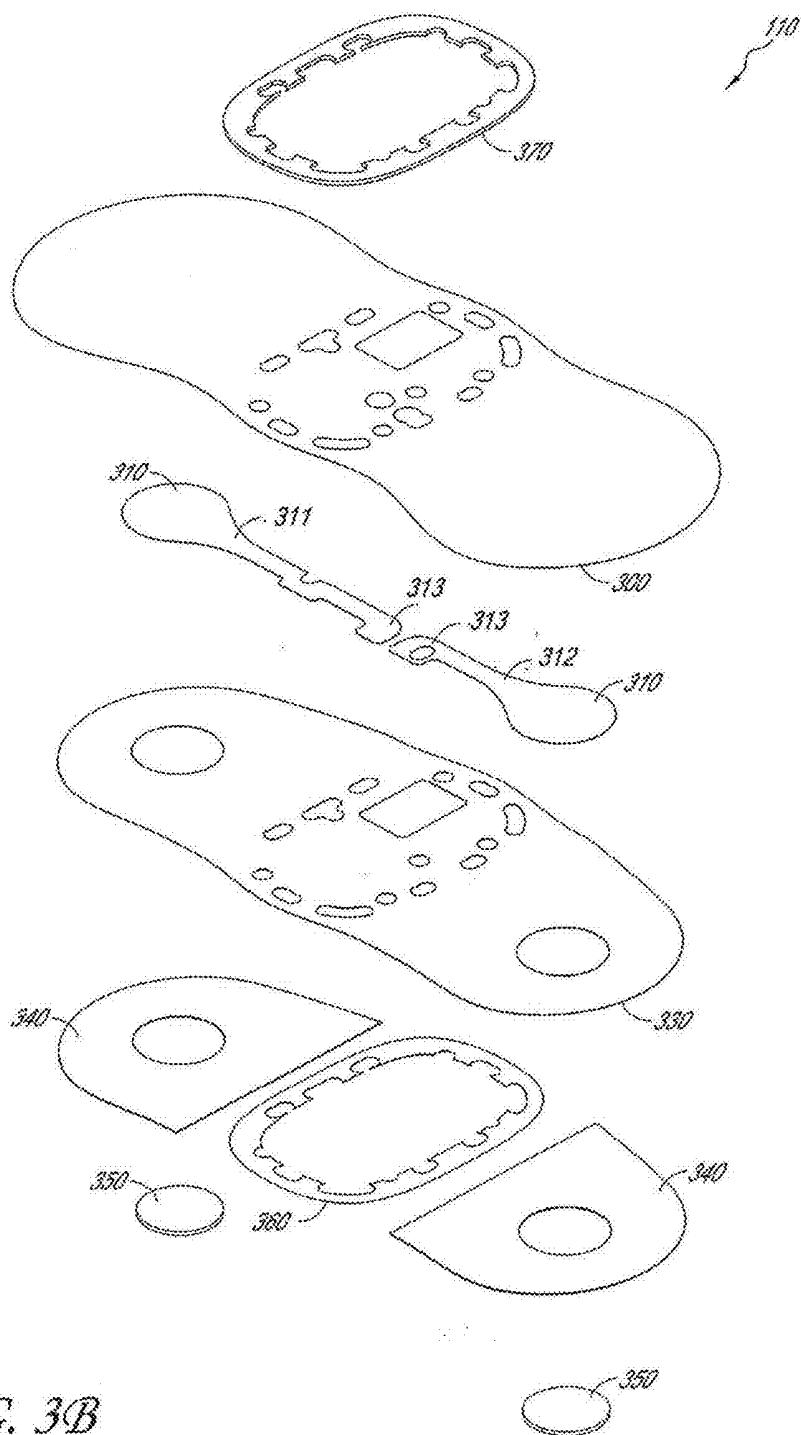

FIG. 3B

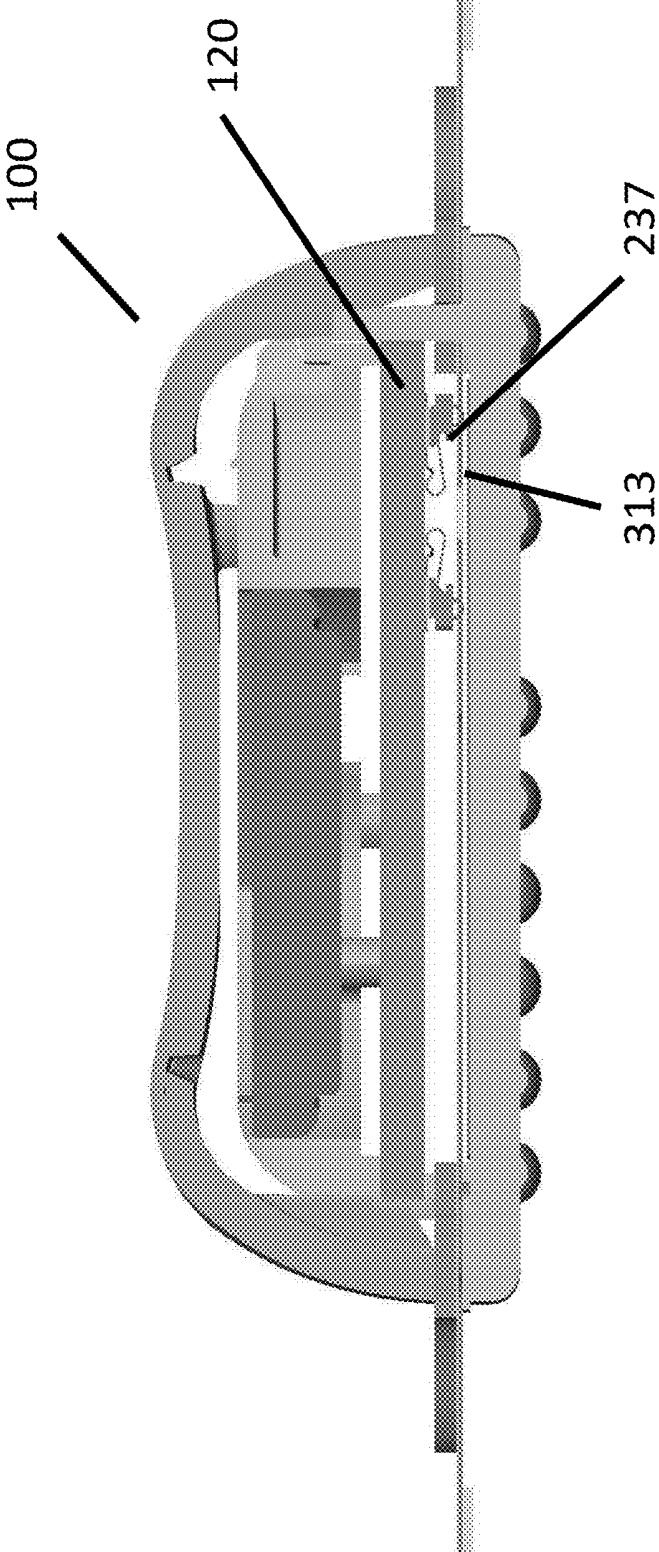

FIG. 3C

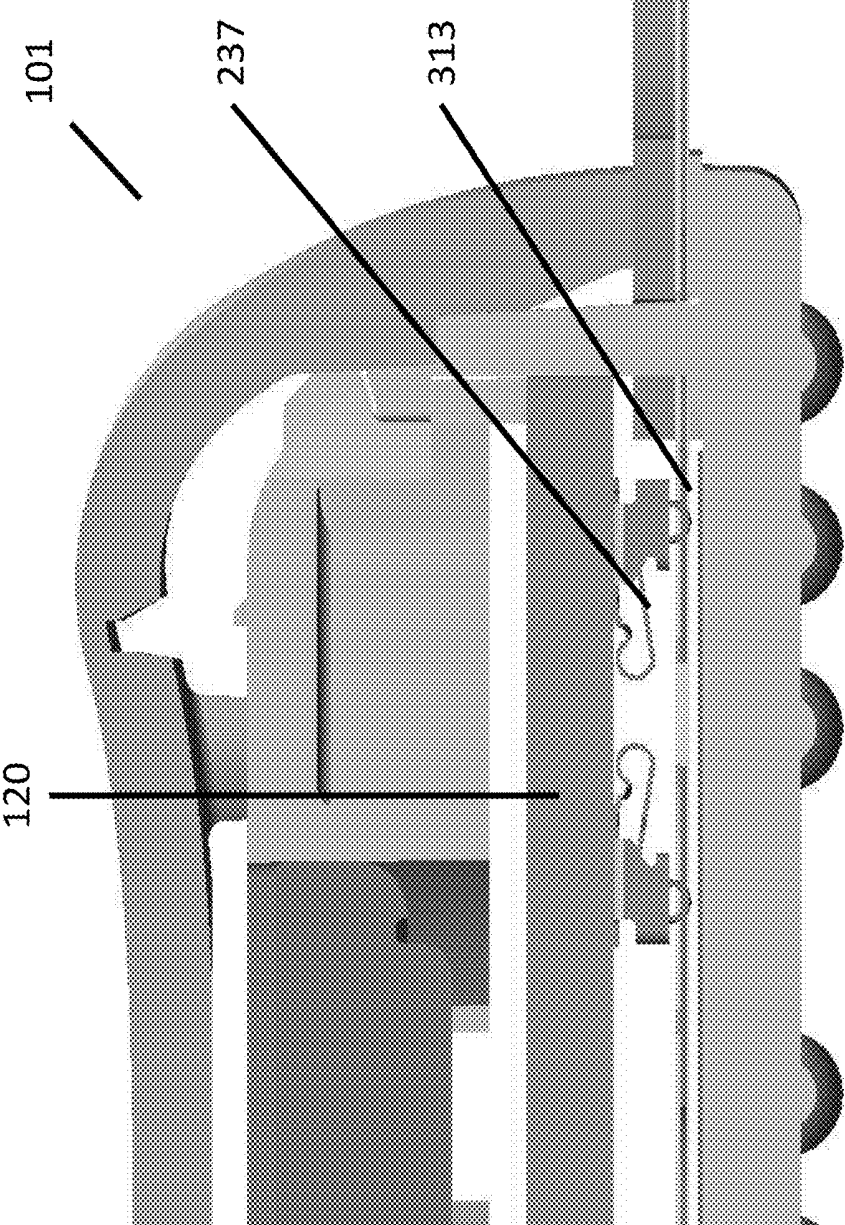

FIG. 3D

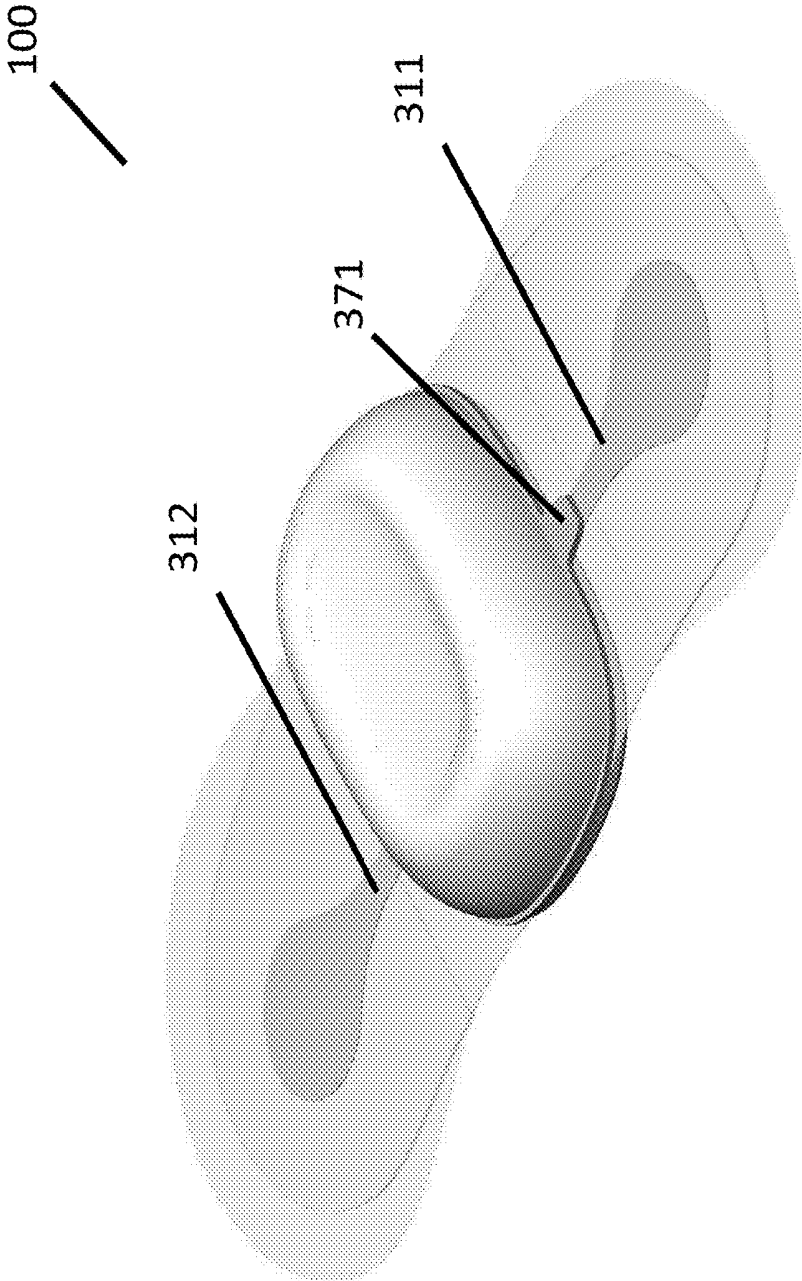

FIG. 3E

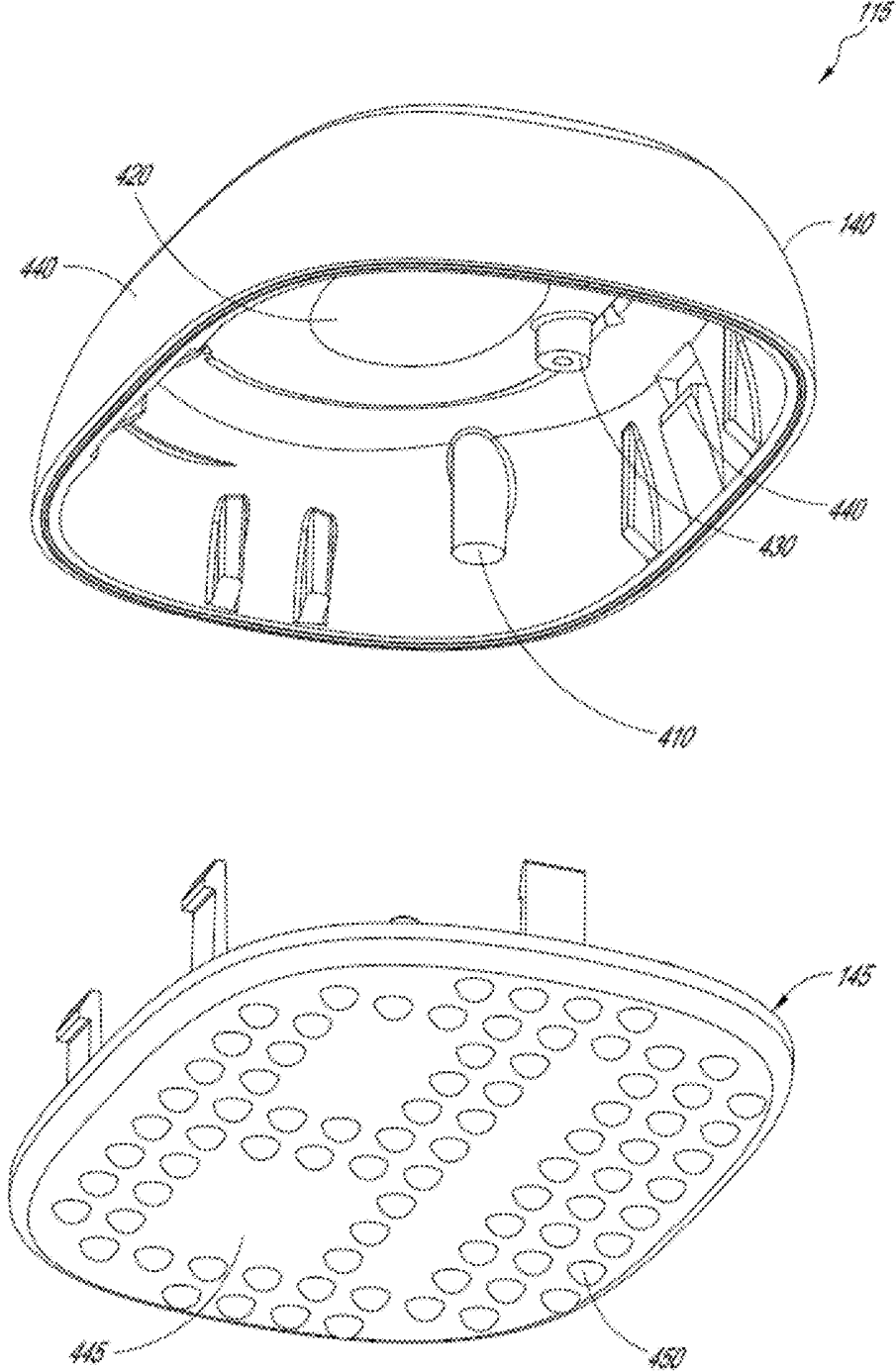
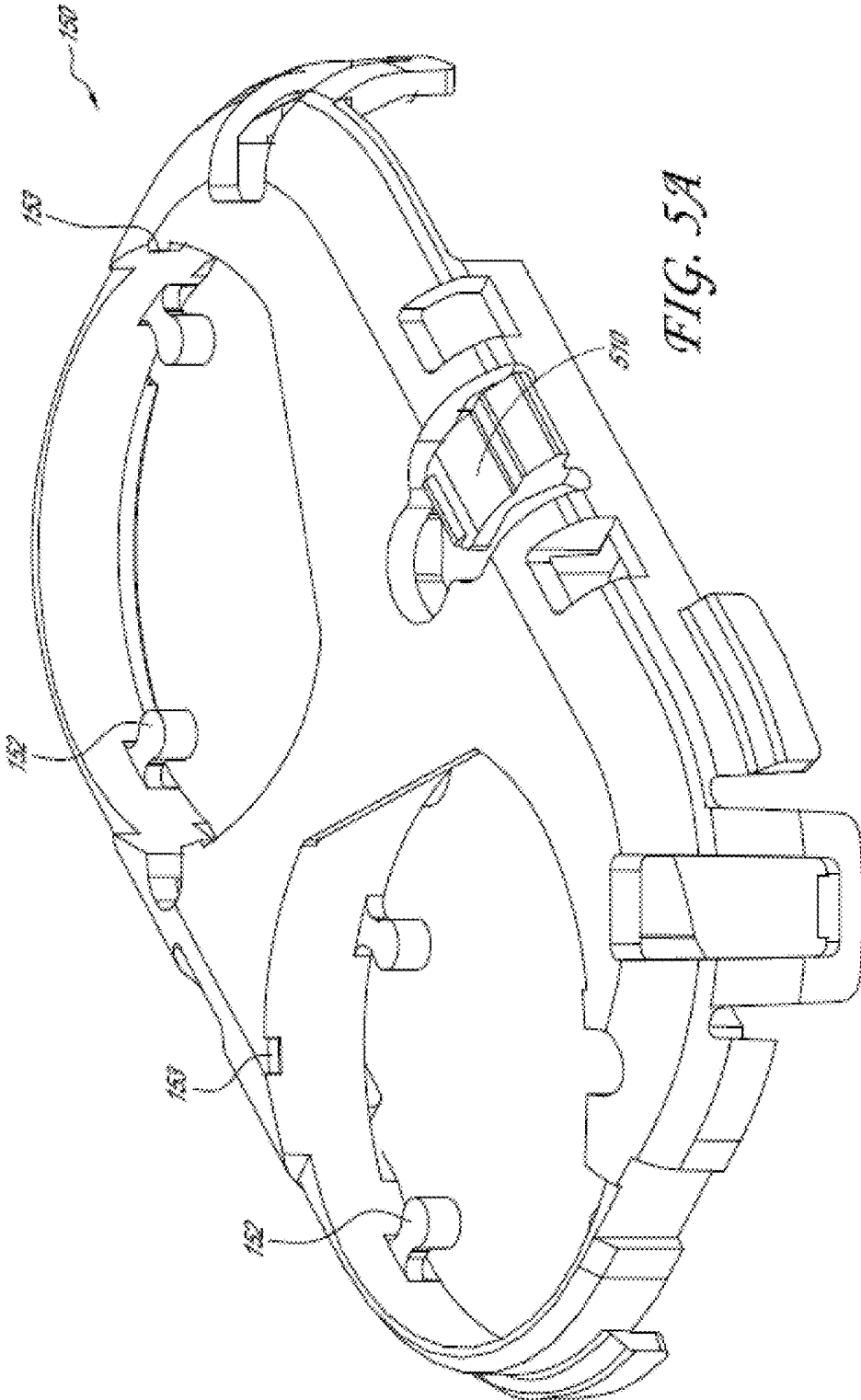

FIG. 4



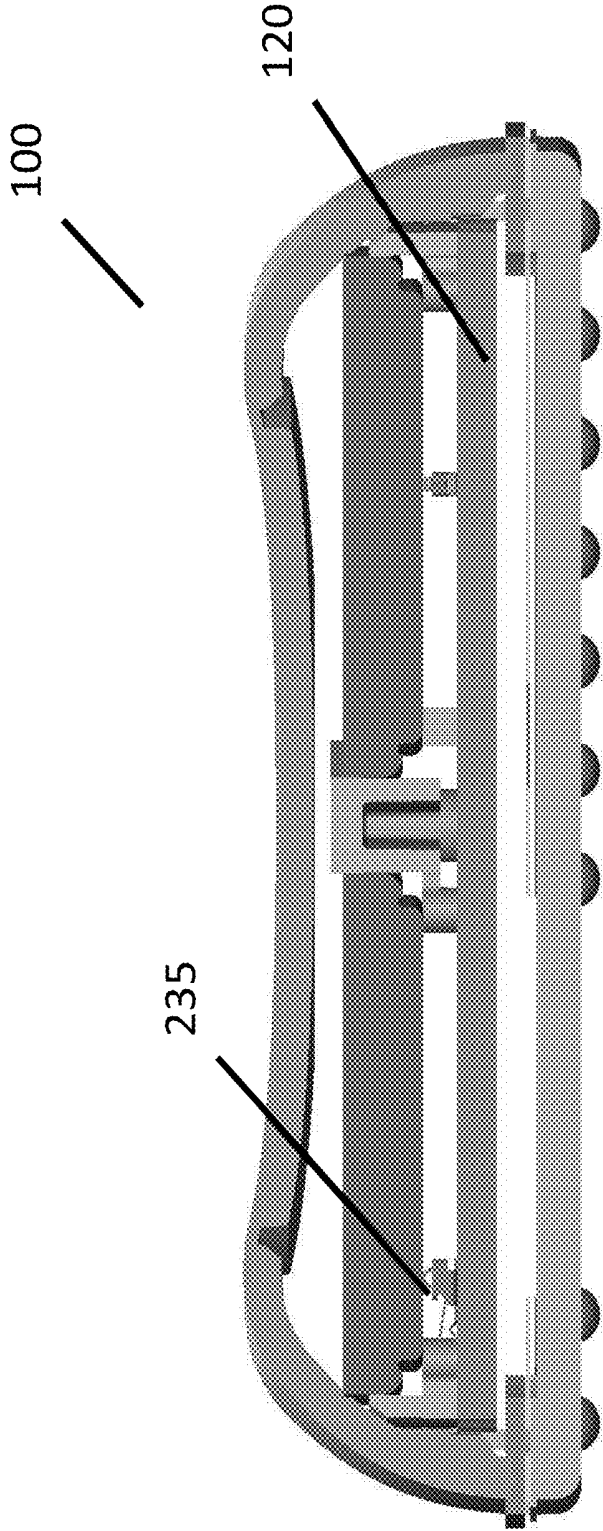

FIG. 5B

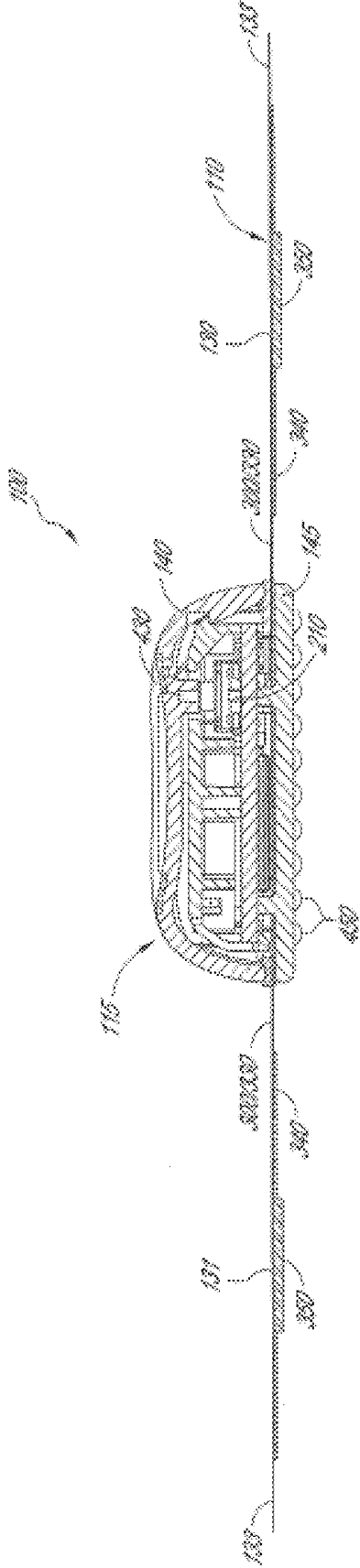
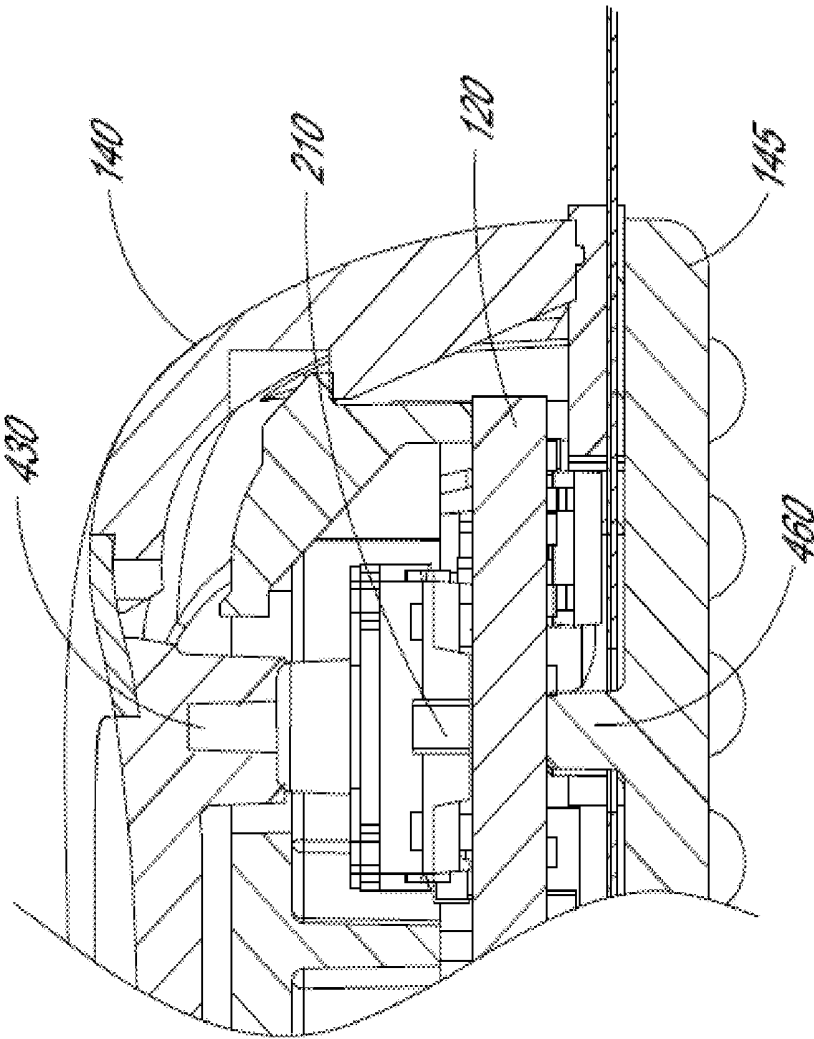

FIG. 6A



*FIG. 6B*

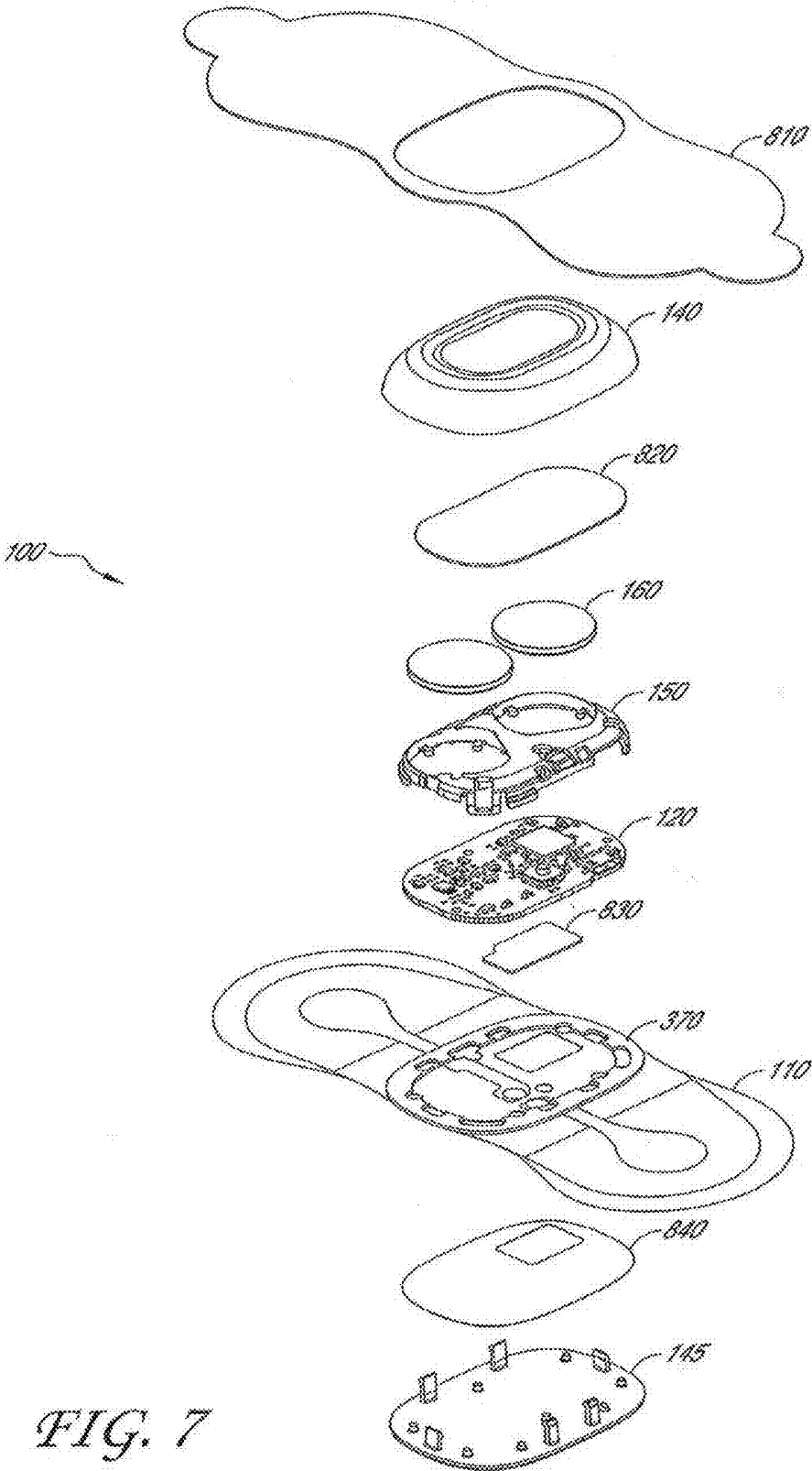
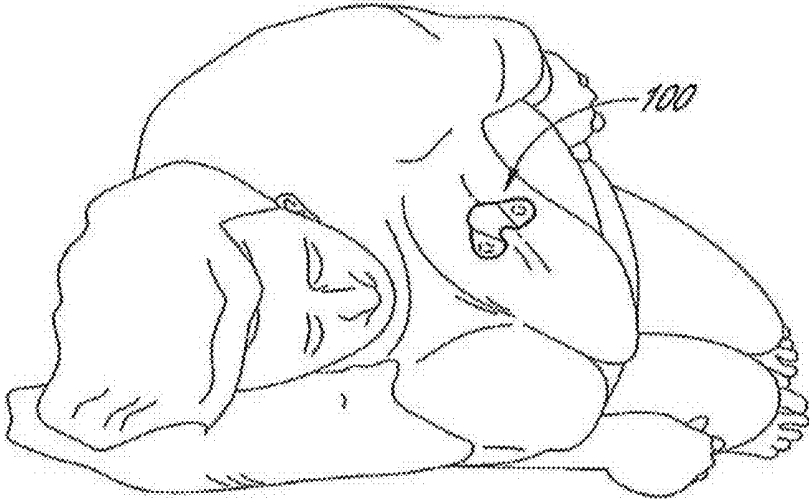
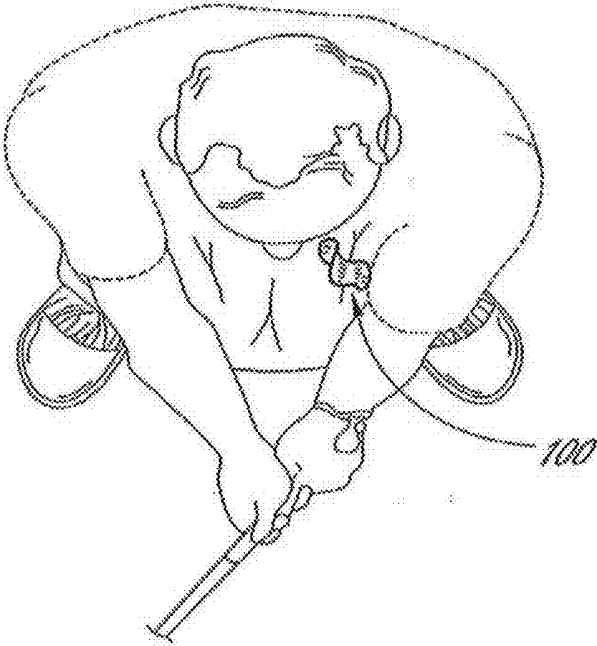

FIG. 7



*FIG. 8A*



*FIG. 8B*

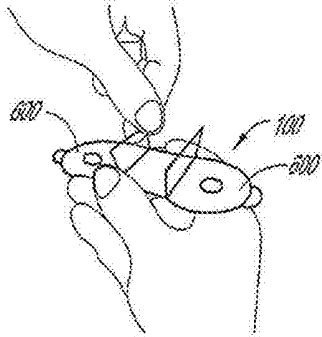

FIG. 9A

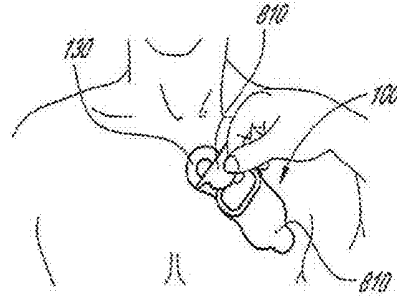

FIG. 9D

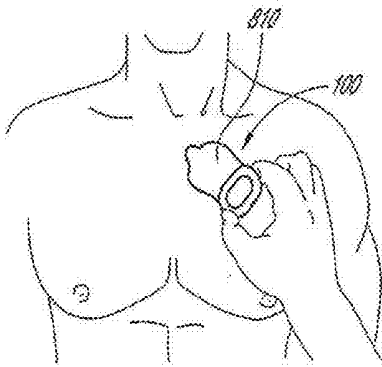

FIG. 9B

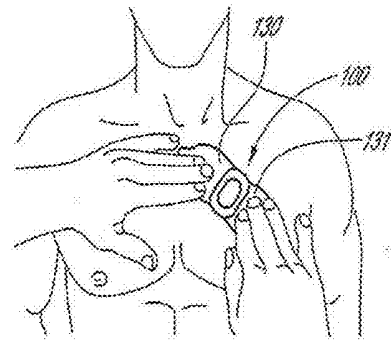

FIG. 9E

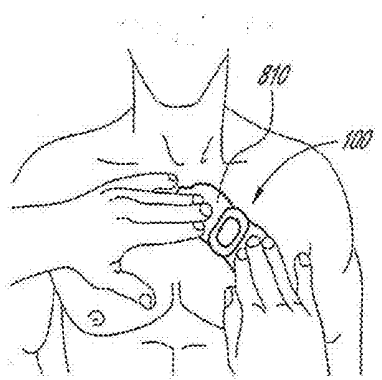

FIG. 9C

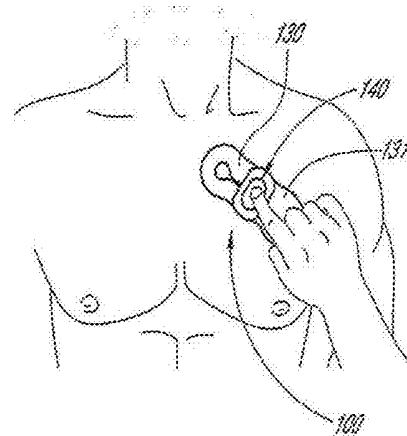

FIG. 9F

## PHYSIOLOGICAL MONITORING DEVICE

### CROSS-REFERENCE TO RELATED APPLICATIONS

[0001] This application is a continuation of U.S. patent application Ser. No. 14/162,656, filed, Jan. 23, 2014, which claims the benefit of U.S. Provisional Application No. 61/756,326, filed Jan. 24, 2013, entitled PHYSIOLOGICAL MONITORING DEVICE. The contents of the aforementioned applications are hereby incorporated by reference in their entirety as if fully set forth herein. The benefit of priority to the foregoing application is claimed under the appropriate legal basis, including, without limitation, under 35 U.S.C. § 119(e).

### BACKGROUND

#### Field of the Invention

[0002] The invention relates generally to medical devices. More specifically, the invention relates to a physiological monitoring device and method for use.

#### Description of the Related Art

[0003] Abnormal heart rhythms, or arrhythmias, may cause various types of symptoms, such as loss of consciousness, palpitations, dizziness, or even death. An arrhythmia that causes such symptoms is often an indicator of significant underlying heart disease. It is important to identify when such symptoms are due to an abnormal heart rhythm, since treatment with various procedures, such as pacemaker implantation or percutaneous catheter ablation, can successfully ameliorate these problems and prevent significant symptoms and death.

[0004] Since the symptoms listed above can often be due to other, less serious causes, a key challenge is to determine when any of these symptoms are due to an arrhythmia. Oftentimes, arrhythmias occur infrequently and/or episodically, making rapid and reliable diagnosis difficult. Currently, cardiac rhythm monitoring is primarily accomplished through the use of devices, such as Holter monitors, that use short-duration (<1 day) electrodes affixed to the chest. Wires connect the electrodes to a recording device, usually worn on a belt. The electrodes need daily changing and the wires are cumbersome. The devices also have limited memory and recording time. Wearing the device interferes with patient movement and often precludes performing certain activities while being monitored, such as bathing. All of these limitations severely hinder the diagnostic usefulness of the device, the compliance of patients using the device and the likelihood of capturing all important information. Lack of compliance and the shortcomings of the devices often lead to the need for additional devices, follow-on monitoring or other tests to make a correct diagnosis.

[0005] Current methods to correlate symptoms with the occurrence of arrhythmias, including the use of cardiac rhythm monitoring devices, such as Holter monitors and cardiac event recorders, are often not sufficient to allow an accurate diagnosis to be made. In fact, Holter monitors have been shown to not lead to a diagnosis up to 90% of the time (“Assessment of the Diagnostic Value of 24-Hour Ambulatory Electrocardiographic Monitoring”, by D E Ward et al. Biotelemetry Patient Monitoring, vol. 7, published in 1980).

[0006] Additionally, the medical treatment process to actually obtain a cardiac rhythm monitoring device and initiate monitoring is typically very complicated. There are usually numerous steps involved in ordering, tracking, monitoring, retrieving, and analyzing the data from such a monitoring device. In most cases, cardiac monitoring devices used today are ordered by a cardiologist or a cardiac electrophysiologist (EP), rather than the patient's primary care physician (PCP). This is of significance since the PCP is often the first physician to see the patient and determine that the patient's symptoms could be due to an arrhythmia. After the patient sees the PCP, the PCP will make an appointment for the patient to see a cardiologist or an EP. This appointment is usually several weeks from the initial visit with the PCP, which in itself leads to a delay in making a potential diagnosis as well as increases the likelihood that an arrhythmia episode will occur and go undiagnosed. When the patient finally sees the cardiologist or EP, a cardiac rhythm monitoring device will usually be ordered. The monitoring period can last 24-48 hours (Holter monitor) or up to a month (cardiac event monitor or mobile telemetry device). Once the monitoring has been completed, the patient typically must return the device to the clinic, which itself can be an inconvenience. After the data has been processed by the monitoring company or by a technician on-site at a hospital or office, a report will finally be sent to the cardiologist or EP for analysis. This complex process results in fewer patients receiving cardiac rhythm monitoring than would ideally receive it.

[0007] To address some of these issues with cardiac monitoring, the assignee of the present application developed various embodiments of a small, long-term, wearable, physiological monitoring device. One embodiment of the device is the Zio® Patch ([www.irhythmtech.com](http://www.irhythmtech.com)). Various embodiments are also described, for example, in U.S. Pat. Nos. 8,150,502, 8,160,682, 8,244,335, 8,560,046, and 8,538,503, the full disclosures of which are hereby incorporated by reference. Generally, the physiological monitors described in the above references fit comfortably on a patient's chest and are designed to be worn for at least one week and typically two to three weeks. The monitors detect and record cardiac rhythm signal data continuously while the device is worn, and this cardiac rhythm data is then available for processing and analysis.

[0008] These smaller, long-term physiological monitoring devices provided many advantages over prior art devices. At the same time, further improvements are desired. One of the most meaningful areas for improvement exists around increasing fidelity of the recorded ECG signal. This is particularly important for single-channel embodiments where a second vector of ECG is not available to clarify whether aberrances in signal are due to arrhythmia or signal artifact. Increases in signal to noise ratio as well as reduction of motion artifact improve efficiency in both algorithmic and human analysis of the recorded ECG signal.

[0009] Signal quality is important throughout the duration of wear, but it is particularly critical where the patient marks the record, indicating an area of symptomatic clinical significance. Marking the record is most easily enabled through a trigger located on the external surface of the device. However, since the trigger is part of a skin-contacting platform with integrated electrodes, the patient can introduce significant motion artifacts when feeling for the trigger.

A desirable device improvement would be a symptom trigger that can be activated with minimal addition of motion artifact.

[0010] Secondly, patient compliance and device adhesion performance are two factors that govern the duration of the ECG record and consequently the diagnostic yield. Compliance can be increased by improving the patient's wear experience, which is affected by wear comfort, device appearance and the extent to which the device impedes the normal activities of daily living. Given that longer ECG records provide greater diagnostic yield and hence value, improvements to device adhesion and patient compliance are desirable.

[0011] Finally, it is desirable for the device to be simple and cost effective to manufacture, enabling scalability at manufacturing as well as higher quality due to repeatability in process. Simplicity of manufacture can also lead to ease of disassembly, which enables the efficient recovery of the printed circuit board for quality-controlled reuse in another device. Efficient reuse of this expensive component is critical for decreasing the cost of the diagnostic monitor. At least some of the objectives will be met by the embodiments described below.

#### BRIEF SUMMARY

[0012] Embodiments described herein are directed to a physiological monitoring device that may be worn continuously and comfortably by a human or animal subject for at least one week or more and more typically two to three weeks or more. In one embodiment, the device is specifically designed to sense and record cardiac rhythm (i.e., electrocardiogram, ECG) data, although in various alternative embodiments one or more additional physiological parameters may be sensed and recorded. The physiological monitoring device includes a number of features to facilitate and/or enhance the patient experience, to make diagnosis of cardiac arrhythmias more accurate, and to make manufacture of the device more simple and cost effective.

[0013] In some embodiments, an electronic device for monitoring physiological signals in a mammal comprises:

[0014] at least two flexible wings extending laterally from a rigid housing, wherein the flexible wings comprise a first set of materials which enable the wings to conform to a surface of the mammal and the rigid housing comprises a second set of materials;

[0015] a printed circuit board assembly housed within the rigid housing, wherein the rigid housing is configured to prevent deformation of the printed circuit board in response to movement of the mammal;

[0016] at least two electrodes embedded within the flexible wings, the electrodes configured to provide conformal contact with the surface of the mammal and to detect the physiological signals of the mammal;

[0017] at least two electrode traces embedded within the wings and mechanically decoupled from the rigid housing, the electrode traces configured to provide conformal contact with the surface of the mammal and transmit electrical signals from the electrodes to the printed circuit board assembly; and,

[0018] at least one hinge portion connecting the wings to the rigid housing, the hinge portions configured to flex freely at the area where it is joined to the rigid housing.

[0019] In certain embodiments, each wing may comprise an adhesive. In embodiments, the electrodes can be in the same plane as the adhesive. In certain embodiments, each wing comprises at least one rim, wherein the rim is thinner than an adjacent portion of each wing. The rigid housing may further comprise dimples configured to allow for air-flow between the rigid housing and the surface of the mammal. In certain embodiments, the rim is configured to prevent the release of a portion of the wing from the surface of the mammal. In some embodiments, an electronic device for monitoring physiological systems may comprise a measuring instrument configured to detect motion signals in at least one axis. This measuring instrument may be an accelerometer that can be configured to detect motion signals in three axes.

[0020] In embodiments, the motion signals can be collected in time with the physiological signals. In certain embodiments, a motion artifact is identified when the physiological signals and the motion signals match. Further embodiments may call for an event trigger coupled to the printed circuit board assembly. In some embodiments, the event trigger input is supported by the rigid housing so as to prevent mechanical stress on the printed circuit board when the trigger is activated. The event trigger may be concave and larger than a human finger such that the event trigger is easily located. In certain embodiments, the electrode traces are configured to minimize signal distortion during movement of the mammal. In particular embodiments, gaskets may be used as a means for sealable attachment to the rigid housing.

[0021] In certain embodiments, a method for monitoring physiological signals in a mammal may comprise:

[0022] attaching an electronic device to the mammal, wherein the device comprises:

[0023] at least two electrodes configured to detect physiological signals from the mammal,

[0024] at least one measuring instrument configured to detect secondary signals, and

[0025] at least two electrode traces connected to the electrodes and a rigid housing; and,

[0026] comparing the physiological signals to the secondary signals to identify an artifact.

[0027] In certain embodiments, identification of an artifact comprises a comparison between the frequency spectrum of the physiological signals and the frequency spectrum of the secondary signals. In embodiments, the secondary signals comprise motion signals that may be used to derive the activity and position of the mammal. In certain embodiments, the secondary signals are collected in three axes. In some embodiments, a tertiary signal may also be collected. In certain embodiments, the secondary signals comprise information about the connection between the electronic device and the mammal. In some embodiments, the secondary signals may be used to detect when the mammal is sleeping.

[0028] In some embodiments, a method of removing and replacing portions of a modular physiological monitoring device may comprise

[0029] applying the device of claim 1 to a mammal for a period of time greater than 7 days and collecting physiological data;

[0030] using the device of claim 1 to detect a first set of physiological signals;

[0031] removing the device of claim 1 from the surface of the mammal;

[0032] removing a first component from the device of claim 1; and,

[0033] incorporating the first component into a second physiological monitoring device, the second physiological monitoring device configured to detect a second set of physiological signals.

[0034] In some embodiments, the first component is electrically connected to other device components without the use of a permanent connection. In some embodiments, the device may further comprise spring connections. In certain embodiments, the first component may be preserved for a second use by a rigid housing to prevent damage. In particular embodiments, the first component is secured within a device by a mechanism that is capable of re-securing a second component once the first component is removed.

[0035] These and other aspects and embodiments of the invention are described in greater detail below, with reference to the drawing figures.

#### BRIEF DESCRIPTION OF THE DRAWINGS

[0036] FIGS. 1A and 1B are perspective and exploded views, respectively, of a physiological monitoring device, according to one embodiment;

[0037] FIGS. 2A and 2B are top perspective and bottom perspective views, respectively, of a printed circuit board assembly of the physiological monitoring device;

[0038] FIGS. 3A-E are perspective and exploded views of a flexible body and gasket of the physiological monitoring device;

[0039] FIG. 4 is an exploded view of a rigid housing of the physiological monitoring device;

[0040] FIG. 5A-B is a perspective view of a battery holder of the physiological monitoring device;

[0041] FIG. 6A and 6B are cross sectional views of the physiological monitoring device;

[0042] FIG. 7 is an exploded view of the physiological monitoring device including a number of optional items, according to one embodiment;

[0043] FIGS. 8A and 8B are perspective views of two people wearing the physiological monitoring device, illustrating how the device bends to conform to body movement and position; and

[0044] FIGS. 9A-9F illustrate various steps for applying the physiological monitor to a patient's body, according to one embodiment.

#### DETAILED DESCRIPTION

[0045] The following description is directed to a number of various embodiments. The described embodiments, however, may be implemented and/or varied in many different ways without departing from the scope of the invention. For example, the described embodiments may be implemented in any suitable device, apparatus, or system to monitor any of a number of physiological parameters. For example, the following discussion focuses primarily on long-term, patch-based cardiac rhythm monitoring devices. In one alternative embodiment, a physiological monitoring device may be used, for example, for pulse oximetry and diagnosis of obstructive sleep apnea. In various alternative embodiments, one size of physiological monitor may be used for adult patients and another size may be used for pediatric patients.

The method of using a physiological monitoring device may also vary. In some cases, a device may be worn for one week or less, while in other cases, a device may be worn for at least seven days and/or for more than seven days, for example between fourteen days and twenty-one days or even longer. Many other alternative embodiments and applications of the described technology are possible. Thus, the following description is provided for exemplary purposes only. Throughout the specification, reference may be made to the term "conformal." It will be understood by one of skill in the art that the term "conformal" as used herein refers to a relationship between surfaces or structures where a first surface or structure fully adapts to the contours of a second surface or structure.

[0046] Referring to FIGS. 1A and 1B, perspective and exploded views of one embodiment of a physiological monitoring device 100 are provided. As seen in FIG. 1A, physiological monitoring device 100 may include a flexible body 110 coupled with a watertight, rigid housing 115. Flexible body 110 (which may be referred to as "flexible substrate" or "flexible construct") typically includes two wings 130, 131, which extend laterally from rigid housing 115, and two flexible electrode traces 311, 312, each of which is embedded in one of wings 130, 131. Each electrode trace 311, 312 is coupled, on the bottom surface of flexible body 110, with a flexible electrode (not visible in FIG. 1A). The electrodes are configured to sense heart rhythm signals from a patient to which monitoring device 100 is attached. Electrode traces 311, 312 then transmit those signals to electronics (not visible in FIG. 1A) housed in rigid housing 115. Rigid housing 115 also typically contains a power source, such as one or more batteries.

[0047] As will be explained in further detail below, the combination of a highly flexible body 110, including flexible electrodes and electrode traces 311, 312, with a very rigid housing 115 may provide a number of advantages. For example, flexible body 110 includes a configuration and various features that facilitate comfortable wearing of device 100 by a patient for fourteen (14) days or more without removal. Rigid housing 115, which typically does not adhere to the patient in the embodiments described herein, includes features that lend to the comfort of device 100. Rigid housing 115 also protects the electronics and power source contained in housing 120, enhances the ability of a patient to provide an input related to a perceived cardiac event, and allows for simple manufacturing and reusability of at least some of the contents of housing 115. These and other features of physiological monitoring device 100 are described in greater detail below.

[0048] Referring now to FIG. 1B, a partially exploded view of physiological monitoring device 100 illustrates component parts that make up, and that are contained within, rigid housing 115 in greater detail. In this embodiment, rigid housing 115 includes an upper housing member 140, which detachably couples with a lower housing member 145. Sandwiched between upper housing member 140 and lower housing member 145 are an upper gasket 370, and a lower gasket 360 (not visible on FIG. 1B but just below upper gasket 370). Gaskets 370, 360 help make rigid housing member 115 watertight when assembled. A number of components of monitoring device 100 may be housed between upper housing member 140 and lower housing member 145. For example, in one embodiment, housing 115 may contain a portion of flexible body 110, a printed circuit

board assembly (PCBA) **120**, a battery holder **150**, and two batteries **160**. Printed circuit board assembly **120** is positioned within housing **115** to contact electrode traces **311**, **312** and batteries **160**. In various embodiments, one or more additional components may be contained within or attached to rigid housing **115**. Some of these optional components are described further below, in reference to additional drawing figures.

[0049] Battery holder **150**, according to various alternative embodiments, may hold two batteries (as in the illustrated embodiment), one battery, or more than two batteries. In other alternative embodiments, other power sources may be used. In the embodiment shown, battery holder **150** includes multiple retain tabs **153** for holding batteries **160** in holder **150**. Additionally, battery holder **150** includes multiple feet **152** to establish correct spacing of batteries **160** from the surface of PCBA **120** and ensure proper contact with spring fingers **235** and **236**. Spring fingers **235** and **236** are used in this embodiment rather than soldering batteries **160** to PCBA **120**. Although soldering may be used in alternative embodiments, one advantage of spring fingers **235** and **236** is that they allow batteries **160** to be removed from PCBA **120** and holder **150** without damaging either of those components, thus allowing for multiple reuses of both. Eliminating solder connections also simplifies and speeds up assembly and disassembly of monitoring device **100**.

[0050] In some embodiments, upper housing member **140** may act as a patient event trigger. When a patient is wearing physiological monitoring device **100** for cardiac rhythm monitoring, it is typically advantageous for the patient to be able to register with device **100** (i.e., log into the device's memory) any cardiac events perceived by the patient. If the patient feels what he/she believes to be an episode of heart arrhythmia, for example, the patient may somehow trigger device **100** and thus provide a record of the perceived event. At some later time, the patient's recorded perceived event could be compared with the patient's actual heart rhythm, recorded by device **100**, and this may help determine whether the patient's perceived events correlate with actual cardiac events. One problem with patient event triggers in currently available wearable cardiac rhythm monitoring devices, however, is that a small trigger may be hard to find and/or activate, especially since the monitoring device is typically worn under clothing. Additionally, pressing a trigger button may affect the electronics and/or the electrodes on the device in such a way that the recorded heart rhythm signal at that moment is altered simply by the motion caused to the device by the patient triggering. For example, pressing a trigger may jar one or both of the electrodes in such a way that the recorded heart rhythm signal at that moment appears like an arrhythmia, even if no actual arrhythmia event occurred. Additionally, there is a chance that the trigger may be inadvertently activated, for instance while sleeping or laying on the monitoring device.

[0051] In the embodiment shown in FIGS. 1A and 1B, however, rigid housing **115** is sufficiently rigid, and flexible body **110** is sufficiently flexible, that motion applied to housing **115** by a patient may rarely or ever cause an aberrant signal to be sensed by the electrodes. In this embodiment, the central portion of upper housing member **140** is slightly concave and, when pressed by a patient who is wearing device **100**, this central portion depresses slightly to trigger a trigger input on PCBA **120**. Because the entire upper surface of rigid housing **115** acts as the patient event

trigger, combined with the fact that it is slightly concave, it will generally be quite easy for a patient to find and push down the trigger, even under clothing. Additionally, the concave nature of the button allows it to be recessed which protects it from inadvertent activations. Thus, the present embodiment may alleviate some of the problems encountered with patient event triggers on currently available heart rhythm monitors. These and other aspects of the features shown in FIGS. 1A and 1B will be described in further detail below.

[0052] Referring now to FIGS. 2A and 2B, printed circuit board assembly **120** (or "PCBA") may include a top surface **220**, a bottom surface **230**, a patient trigger input **210** and spring contacts **235**, **236**, and **237**. Printed circuit board assembly **120** may be used to mechanically support and electrically connect electronic components using conductive pathways, tracks or electrode traces **311**, **312**. Furthermore, because of the sensitive nature of PCBA **120** and the requirement to mechanically interface with rigid body **115**, it is beneficial to have PCBA **120** be substantially rigid enough to prevent unwanted deflections which may introduce noise or artifact into the ECG signal. This is especially possible during patient trigger activations when a force is transmitted through rigid body **115** and into PCBA **120**. One way to ensure rigidity of the PCBA is to ensure that the thickness of the PCBA is relatively above a certain value. For example, a thickness of at least about 0.08 cm is desirable and, more preferably, a thickness of at least about 0.17 cm is desirable. In this application, PCBA **120** may also be referred to as, or substituted with, a printed circuit board (PCB), printed wiring board (PWB), etched wiring board, or printed circuit assembly (PCA). In some embodiments, a wire wrap or point-to-point construction may be used in addition to, or in place of, PCBA **120**. PCBA **120** may include analog circuits and digital circuits.

[0053] Patient trigger input **210** may be configured to relay a signal from a patient trigger, such as upper housing member **140** described above, to PCBA **120**. For example, patient trigger input **210** may be a PCB switch or button that is responsive to pressure from the patient trigger (i.e., the upper surface of upper housing portion **140**). In various embodiments, patient trigger input **210** may be a surface mounted switch, a tactile switch, an LED illuminated tactile switch, or the like. In some embodiments, patient trigger input **210** may also activate an indicator, such as an LED.

[0054] One important challenge in collecting heart rhythm signals from a human or animal subject with a small, two-electrode physiological monitoring device such as device **100** described herein, is that having only two electrodes can sometimes provide a limited perspective when trying to discriminate between artifact and clinically significant signals. For example, when a left-handed patient brushes her teeth while wearing a small, two-electrode physiological monitoring device on her left chest, the tooth brushing may often introduce motion artifact that causes a recorded signal to appear very similar to Ventricular Tachycardia, a serious heart arrhythmia. Adding additional leads (and, hence, vectors) is the traditional approach toward mitigating this concern, but this is typically done by adding extra wires adhered to the patient's chest in various locations, such as with a Holter monitor. This approach is not consistent with a small, wearable, long term monitor such as physiological monitoring device **100**.

[0055] An alternate approach to the problem described above is to provide one or more additional data channels to aid signal discrimination. In some embodiments, for example, device 100 may include a data channel for detecting patch motion. In certain embodiments, an accelerometer may provide patch motion by simply analyzing the change in magnitude of a single axis measurement, or alternatively of the combination of all three axes. The accelerometer may record device motion at a sufficient sampling rate to allow algorithmic comparison of its frequency spectrum with that of the recorded ECG signal. If there is a match between the motion and recorded signal, it is clear that the device recording in that time period is not from a clinical (e.g., cardiac) source, and thus that portion of the signal can be confidently marked as artifact. This technique may be particularly useful in the tooth brushing motion example aforementioned, where the rapid frequency of motion as well as the high amplitude artifact is similar to the heart rate and morphology, respectively, of a potentially life-threatening arrhythmia like Ventricular Tachycardia.

[0056] In some embodiments, using the magnitude of all three axes for such an analysis would smooth out any sudden changes in values due to a shift in position rather than a change in activity. In other embodiments, there may be some advantage in using a specific axis of measurement such as along the longitudinal axis of the body to focus on a specific type of artifact introduced by upward and downward movements associated with walking or running. In a similar vein, the use of a gyroscope in conjunction with the accelerometer may provide further resolution as to the nature of the motion experienced. While whole body movements may be sufficiently analyzed with an accelerometer on its own, specific motion of interest such as rotational motion due to arm movement is sufficiently complex that an accelerometer alone might not be able to distinguish.

[0057] In addition to detecting motion artifact, an accelerometer tuned to the dynamic range of human physical activities may provide activity levels of the patient during the recording, which can also enhance accuracy of algorithmic true arrhythmia detection. Given the single-lead limitation of device 100, arrhythmias that require observation of less prominent waves (e.g. P-wave) in addition to rate changes such as Supraventricular Tachycardia pose challenges to both computerized algorithms as well as the trained human eye. This particular arrhythmia is also characterized by the sudden nature of its onset, which may be more confidently discriminated from a non-pathological Sinus Tachycardia if a sudden surge in the patient's activity level is detected at the same time as the increase in heart rate. Broadly speaking, the provision of activity information to clinical professionals may help them discriminate between exercise-induced arrhythmia versus not. As with motion artifact detection, a single-axis accelerometer measurement optimized to a particular orientation may aid in more specifically determining the activity type such as walking or running. This additional information may help explain symptoms more specifically and thereby affect the subsequent course of therapeutic action.

[0058] In certain embodiments, an accelerometer with 3 axes may confer advantages beyond what magnitude of motions can provide. When the subject is not rapidly moving, 3-dimensional accelerometer readings may approximate the tilt of PCBA 120, and therefore body orientation relative to its original orientation. The original body orientation can

be assumed to be in either an upright or supine position which is required for appropriate positioning and application of the device to the body. This information may aid in ruling out certain cardiac conditions that manifest as beat-to-beat morphology changes, such as cardiac alternans where periodic amplitude changes are observed, often in heart failure cases. Similar beat-to-beat morphology changes are observable in healthy subjects upon shift in body position due to the shift in heart position relative to the electrode vector, for example from an upright to a slouching position. By design, the single-channel device 100 does not have an alternate ECG channel to easily rule out potential pathological shifts in morphology, however, correlation with shifts in body orientation will help explain these normal changes and avoid unnecessary treatment due to false diagnosis.

[0059] In other embodiments, the accelerometer may also be used as a sleep indicator, based on body orientation and movement. When presenting clinical events (e.g., pauses), it is diagnostically helpful to be able to present information in a manner that clearly separates events that occurred during sleep from those during waking hours. In fact, certain algorithms such as for ECG-derived respiratory rate only make sense to run when the patient is in a relatively motionless state and therefore subtle signal modulation introduced by chest movement due to breathing is observable. Respiratory rate information is useful as one channel of information necessary to detect sleep apnea in certain patient populations.

[0060] In certain embodiments, the accelerometer may also be used to detect free-falls, such as fainting. With an accelerometer, device 100 may be able to mark fainting (syncope) and other free-fall events without relying on patient trigger. In order to allow timely detection of such critical events, yet considering the battery and memory limitations of a small, wearable device such as device 100, acquisition of accelerometer readings may be done in bursts, where only interesting information such as a potential free fall is written to memory at a high sampling rate. An expansion of this event-trigger concept is to use specific tapping motions on device 100 as a patient trigger instead of or in conjunction with the button previously described. The use and detection of multiple types of tapping sequences may provide better resolution and accuracy into what exactly the patient was feeling, instead of relying on the patient to manually record their symptom and duration in a trigger log after the fact. An example of such added resolution is to indicate the severity of the symptom by the number of sequential taps.

[0061] Alternatively, in other embodiments, an optical sensors may be used to distinguish between device motion and patient body motion. Further, in additional embodiments, the device may not require a button or trigger.

[0062] Another optional data channel that may be added to physiological monitoring device 100 is a channel for detecting flex and/or bend of device 100. In various embodiments, for example, device 100 may include a strain gauge, piezoelectric sensor or optical sensor to detect motion artifact in device 100 itself and thus help to distinguish between motion artifact and cardiac rhythm data. Yet another optional data channel for device 100 may be a channel for detecting heart rate. For example, a pulse oximeter, microphone or stethoscope may provide heart rate information. Redundant heart rate data may facilitate discrimination of ECG signals from artifact. This is particularly useful in cases where

arrhythmia such as Supraventricular Tachycardia is interrupted by artifact, and decisions must be made whether the episode was actually multiple shorter episodes or one sustained episode. Another data channel may be included for detecting ambient electrical noise. For example, device 100 may include an antenna for picking up electromagnetic interference. Detection of electromagnetic interference may facilitate discrimination of electrical noise from real ECG signals. Any of the above-described data channels may be stored to support future noise discrimination or applied for immediate determination of clinical validity in real-time.

[0063] With reference now to FIGS. 3A and 3B, flexible body 110 is shown in greater detail. As illustrated in FIG. 3A, flexible body 110 may include wings 130, 131, a thin border 133 (or “rim” or “edge”) around at least part of each wing 130, 131, electrode traces 311, 312, and a hinge portion 132 (or “shoulder”) at or near a junction of each wing 130, 131 with rigid housing 115. Also shown in FIG. 3A is upper gasket 370, which is not considered part of flexible body 110 for this description, but which facilitates attachment of flexible body 110 to rigid housing 115.

[0064] Hinge portions 132 are relatively thin, even more flexible portions of flexible body 110. They allow flexible body 110 to flex freely at the area where it is joined to rigid housing 115. This enhances comfort, since when the patient moves, housing 115 can freely lift off of the patient’s skin. Electrode traces 311, 312 are also very thin and flexible, to allow for patient movement without signal distortion. Borders 133 are portions of flexible body 110 that is thinner than immediately adjacent portions and that provide for a smooth transition from flexible body 110 to a patient’s skin, thus preventing edge-lift and penetration of dirt or debris below flexible body 110.

[0065] As shown in greater detail in FIG. 3B, flexible body 110 may include multiple layers. As mentioned previously, upper gasket 370 and lower gasket 360 are not considered part of flexible body 110 for the purposes of this description but are shown for completeness of description. This distinction is for ease of description only, however, and should not be interpreted to limit the scope of the claimed invention. Flexible body 110 may include a top substrate layer 300, a bottom substrate layer 330, an adhesive layer 340, and flexible electrodes 350. Top and bottom substrate layers 300, 330 may be made of any suitable, flexible material, such as one or more flexible polymers. Suitable flexible polymers can include, but are not limited to, polyurethane, polyethylene, polyester, polypropylene, nylon, teflon and carbon impregnated vinyl. The material of substrate layers 300, 330 may be selected based on desired characteristics. For example, the material of substrate layers 300, 330 may be selected for flexibility, resilience, durability, breathability, moisture transpiration, adhesion and/or the like. In one embodiment, for example, top substrate layer 300 may be made of polyurethane, and bottom substrate layer 330 may be made of polyethylene or alternatively polyester. In other embodiments, substrate layers 300, 330 may be made of the same material. In yet another embodiment, substrate layer 330 may contain a plurality of perforations in the area over adhesive layer 340 to provide for even more breathability and moisture transpiration. In various embodiments, physiological monitoring device 100 may be worn continuously by a patient for as many as 14-21 days or more, without removal during the time of wear and with device 100 being worn during showering, exercising and the

like. Thus, the material(s) used and the thickness and configuration of substrate layers 300, 330 may be essential to the function of physiological monitoring device 100. In some embodiments, the material of substrate layers 300, 330 acts as an electric static discharge (ESD) barrier to prevent arcing.

[0066] Typically, top and bottom substrate layers 300, 330 are attached to one another via adhesive placed on one or both layers 300, 330. For example, the adhesive or bonding substance between substrate layers 300, 330 may be an acrylic-based, rubber-based, or silicone-based adhesive. In other alternative embodiments, flexible body 110 may include more than two layers of flexible material.

[0067] In addition to the choice of material(s), the dimensions—thickness, length and width—of substrate layers 300, 330 may be selected based on desired characteristics of flexible body 110. For example, in various embodiments, the thickness of substrate layers 300, 330 may be selected to give flexible body 110 an overall thickness of between about 0.1 mm to about 1.0 mm. According to various embodiments, flexible body 110 may also have a length of between about 7 cm and 15 cm and a width of about 3 cm and about 6 cm. Generally, flexible body 110 will have a length sufficient to provide a necessary amount of separation between electrodes 350. For example, a distance from the center of one electrode 350 to the center of the other electrode 350 should be at least about 6.0 cm and more preferably at least about 8.5 cm. This separation distance may vary, depending on the application. In some embodiments, substrate layers 300, 330 may all have the same thickness. Alternatively, the two substrate layers 300, 330 may have different thicknesses.

[0068] As mentioned above, hinge portions 132 allow the rigid body 115 to lift away from the patient while flexible body 110 remains adhered to the skin. The functionality of hinge portions 132 is critical in allowing the device to remain adhered to the patient throughout various activities that may stretch and compress the skin. Furthermore, hinge portions 132 allow for significantly improved comfort while wearing the device. Generally, hinge portions 132 will be sufficiently wide enough to provide adequate lift of rigid body 115 without creating too large of a peel force on flexible body 110. For example, in various embodiments, the width of hinge portion 132 should be at least about 0.25 cm and more preferably at least about 0.75 cm.

[0069] Additionally, the shape or footprint of flexible body 110 may be selected based on desired characteristics. As seen in FIG. 3A, wings 130, 131 and borders 133 may have rounded edges that give flexible body 110 an overall “peanut” shape. However, wings 130, 131 can be formed in any number of different shapes such as rectangles, ovals, loops, or strips. In the embodiment shown in FIGS. 3A and 3B, the footprint top substrate layer 300 is larger than the footprint of bottom substrate layer 330, with the extension of top substrate layer 300 forming borders 133. Thus, borders 133 are made of the same polyurethane material that top layer 300 is made of. Borders 133 are thinner than an adjacent portion of each wing 130, 131, since they includes only top layer 300. The thinner, highly compliant rim 133 will likely enhance adherence of physiologic monitoring device 100 to a patient, as it provides a transition from an adjacent, slightly thicker portion of wings 130, 131 to the patient’s skin and thus helps prevent the edge of device 110 from peeling up off the skin. Border 133 may also help prevent the collection of

dirt and other debris under flexible body 110, which may help promote adherence to the skin and also enhance the aesthetics of device 100. In alternative embodiments, the footprint of substrate layers 300, 330 may be the same, thus eliminating borders 133.

[0070] While the illustrated embodiments of FIGS. 1A-3B include only two wings 130, 131, which extend from rigid housing 115 in approximately opposite directions (i.e., at a 180-degree angle relative to each other), other configurations are possible in alternative embodiments. For example, in some embodiments, wings 130, 131 may be arranged in an asymmetrical orientation relative to one another and/or one or more additional wings may be included. As long as sufficient electrode spacing is provided to permit physiological signal monitoring, and as long as wings 130, 131 are configured to provide extended attachment to the skin, any suitable configuration and number of wings 130, 131 and electrode traces 311, 312 may be used. The embodiments described above have proven to be advantageous for adherence, patient comfort and accuracy of collected heart rhythm data, but in alternative embodiments it may be possible to implement alternative configurations.

[0071] Adhesive layer 340 is an adhesive that is applied to two portions of the bottom surface of bottom substrate layer 330, each portion corresponding to one of wings 130, 131. Adhesive layer 340 thus does not extend along the portion of bottom substrate layer 330 upon which rigid housing 115 is mounted. Adhesive layer 340 may be made of any suitable adhesive, although certain adhesives have been found to be advantageous for providing long term adhesion to patient skin with relative comfort and lack of skin irritation. For example, in one embodiment, adhesive layer 340 is a hydrocolloid adhesive. In another embodiment, the adhesive layer 340 is comprised of a hydrocolloid adhesive that contains naturally-derived or synthetic absorbent materials which take up moisture from the skin during perspiration.

[0072] Each of the two portions of adhesive layer 340 includes a hole, into which one of electrodes 350 fits. Electrodes 350 made of flexible material to further provide for overall conformability of flexible body 110. In one embodiment, for example, flexible electrodes 350 may be made of a hydrogel 350. Electrodes 350 generally provide conformal, non-irritating contact with the skin to provide enhanced electrical connection with the skin and reduce motion artifact. In some embodiments, hydrogel electrodes 350 may be punched into adhesive layer 340, thus forming the holes and filling them with hydrogel electrodes 350. In one alternative embodiment, electrodes 350 and adhesive 340 may be replaced with an adhesive layer made of a conductive material, such that the entire adhesive layer on the underside of each wing 130, 131 acts as an electrode. Such an adhesive layer may include a hybrid adhesive/conductive substance or adhesive substance mixed with conductive elements or particles. For example, in one embodiment, such an adhesive layer may be a hybrid of a hydrogel and a hydrocolloid adhesive.

[0073] As discussed above, in some embodiments, adhesive layer 340 may cover a portion of the underside of lower substrate layer 330, such that at least a portion of the bottom side of flexible body 110 does not include adhesive layer 340. As seen in FIG. 3A, hinges 132 may be formed in the flexible body 110 as portions of each wing 130, 131 on which adhesive layer 340 is not applied. Hinge portions 132 are generally located at or near the junction of flexible body

110 with rigid housing 115, and thus provide for flexing of device 100 to accommodate patient movement. In some embodiments, hinge portions 132 may have a width that is less than that of adjacent portions of wings 130, 131, thus giving device 100 its “peanut” shape mentioned above. As shown in FIG. 8, as a subject moves, device 100 flexes along with patient movement. Device flexion may be severe and is likely to occur many times during long term monitoring. Hinge portions 132 may allow for dynamic conformability to the subject, while the rigidity of rigid housing 115 may allow housing 115 to pop up off the patient’s skin during device flexion, thus preventing peeling of the device 100 off of the skin at its edge.

[0074] Flexible body 110 further includes two electrode traces 311, 312 sandwiched between upper substrate layer 300 and lower substrate layer 330. Each electrode trace 311, 312 may include an electrode interface portion 310 and an electrocardiogram circuit interface portion 313. As illustrated in FIGS. 3C and 3D, ECG circuit interface portions 313 are in physical contact with spring fingers 237 and provide electrical communication with PCBA 120 when device 100 or zoomed-in device portion 101 is assembled. Electrode interface portions 310 contact hydrogel electrodes 350. Thus, electrode traces 311, 312 transmit cardiac rhythm signals (and/or other physiological data in various embodiments) from electrodes 350 to PCBA 120.

[0075] The material and thickness of electrode traces 311, 312 are important for providing a desired combination of flexibility, durability and signal transmission. For example, in one embodiment, electrode traces 311, 312 may include a combination of silver (Ag) and silver chloride (AgCl). The silver and silver chloride may be disposed in layers. For example, one embodiment of electrode traces 311, 312 may include a top layer of silver, a middle layer of carbon impregnated vinyl, and a bottom (patient-facing) layer of silver chloride. In another embodiment, both top and bottom layers of electrode traces 311, 312 may be made of silver chloride. In one embodiment, the top and bottom layers may be applied to the middle layer in the form of silver ink and silver chloride ink, respectively. In an alternative embodiment, each electrode trace may include only two layers, such as a top layer of silver and a bottom layer of silver chloride. In various embodiments, the material of a bottom layer of each electrode trace 311, 312, such as AgCl, may be selected to match the chemistry of the hydrogel electrodes 350 and create a half-cell with the body of the subject.

[0076] The thickness of the electrode traces 311, 312 may be selected to optimize any of a number of desirable properties. For example, in some embodiments, at least one of the layers of electrode traces 311, 312 can be of a sufficient thickness to minimize or slow depletion of the material from an anode/cathode effect over time. Additionally, the thickness may be selected for a desired flexibility, durability and/or signal transmission quality. Flexible electrode traces 311, 312 generally may help provide conformal contact with the subject’s skin and may help prevent electrodes 350 from peeling or lifting off of the skin, thereby providing strong motion artifact rejection and better signal quality by minimizing transfer of stress to electrodes 350.

[0077] As mentioned above, in some embodiments, top gasket 370 and bottom gasket 360 may be attached upper substrate 300 and lower substrate 330 of flexible body 110. Gaskets 360, 370 may be made of any suitable material, such as urethane, which provides a water tight seal between the

upper housing member **140** and lower housing member **145** of rigid housing **115**. In one embodiment, top gasket **370** and/or bottom gasket **360** may include an adhesive surface. FIG. 3E depicts yet another embodiment where top gasket **370** includes tabs **371** that protrude away from the profile of top housing **140** while still being adhered to upper substrate **300**. The tabs **371** cover a portion of electrode traces **311**, **312** and provide a strain relief for the traces at the point of highest stress where the flexible body meets the rigid housing.

[0078] With reference now to FIG. 4, upper housing member **140** and lower housing member **145** of rigid housing **115** are shown in greater detail. Upper and lower housing members **140**, **145** may be configured, when coupled together with gaskets **360**, **370** in between, to form a watertight enclosure for containing PCBA **120**, battery holder **150**, batteries **160** and any other components contained within rigid housing **115**. Housing members **140**, **145** may be made of any suitable material to protect internal components, such as water resistant plastic. In one embodiment, upper housing member **140** may include a rigid sidewall **440**, a light pipe **410** to transmit visual information from the LEDs on the PCBA through the housing member, a slightly flexible top surface **420**, and an inner trigger member **430** extending inward from top surface **420**. Top surface **420** is configured to be depressed by a patient when the patient perceives what he or she believes to be an arrhythmia or other cardiac event. When depressed, top surface **420** depresses inner trigger member **430**, which contacts and activates trigger input **210** of PCBA **120**. Additionally, as discussed previously, top surface **420** may have a concave shape (concavity facing the inside of housing **115**) to accommodate the shape of a finger. It is believed that the design of upper housing member **140** isolates activation of the trigger input **210** from electrodes **350**, thereby minimizing artifact in the data recording.

[0079] With continued reference to FIG. 4, lower housing member **145** may be configured to detachably connect with upper housing member **140** in such a way that housing members **140**, **145** may be easily attached and detached for reusability of at least some of the component parts of monitoring device **100**. In some embodiments, a bottom surface **445** (patient facing surface) of lower housing member **145** may include multiple dimples **450** (or “bumps,” “protrusions” or the like), which will contact the patient’s skin during use. Dimples **450** may allow for air flow between bottom surface **445** and the patient’s skin, thus preventing a seal from forming between bottom surface **445** and the skin. It is believed that dimples **450** improve comfort and help prevent a perception in currently available devices in which the patient feels as if monitoring device **100** is falling off when it housing **115** lifts off the skin and breaks a seal with the skin. In yet another embodiment the bottom surface **445** of lower housing member **145** may include multiple divots (recesses instead of protrusions) to prevent a seal from forming.

[0080] Referring now to FIG. 5A, battery holder **150** is shown in greater detail. Battery holder **150** may be made of plastic or other suitable material, is configured to be mounted to PCBA **120** and subsequently attached to rigid housing **115**, and is capable of holding two batteries **160** (FIG. 1B). In alternative embodiments, battery holder **150** may be configured to hold one battery or more than two batteries. A plurality of protrusions **152** provide a stable

platform for batteries **160** to be positioned a fixed distance above the surface of PCBA **120**, avoiding unwanted contact with sensitive electronic components yet providing for adequate compression of spring contacts **235** (FIG. 5B). Protrusions **153** lock batteries **160** into position and resist the upward force on the batteries from spring contacts **235**. Battery holder **150** also positions batteries appropriately **160** to provide for adequate compression of spring contacts **236**. Use of battery holder **150** in conjunction with spring contacts **235** and **236** allows for batteries **160** to be electrically connected to PCBA **120** while still having additional electronic components between batteries **160** and PCBA **120** and maintain a very compact assembly. Battery holder **150** may include a flexible hook **510** which engages a corresponding rigid hook **440** of upper housing member **140**. Under normal assembly conditions the flexible hook **510** remains securely mated with rigid hook **440**. For disassembly, flexible hook **510** can be pushed and bent using an appropriate tool passed through top housing **140** causing it to disengage from rigid hook **440** and subsequently allow top housing **140** to be removed.

[0081] With reference now to FIG. 6A and 6B, physiological monitoring device **100** is shown in side view cross-section. As shown in 6A, physiological monitoring device **100** may include flexible body **110** coupled with rigid housing **115**. Flexible body **110** may include top substrate layer **300**, bottom substrate layer **330**, adhesive layer **340** and electrodes **350**. Electrode traces **311**, **312** are also typically part of flexible body **110** and are embedded between top substrate layer **300** and bottom substrate layer **330**, but they are not shown in FIG. 6. Flexible body **110** forms two wings **130**, **131**, extending to either side of housing **115**, and a border **133** surrounding at least part of each wing **130**, **131**. Rigid housing **115** may include an upper housing member **140** coupled with a lower housing member **145** such that it sandwiches a portion of flexible body **110** in between and provides a watertight, sealed compartment for PCBA **120**. Upper housing member **140** may include inner trigger member **430**, and PCBA may include patient trigger member **210**. As discussed previously, lower housing member **145** may include multiple dimples **450** or divots to enhance the comfort of the monitoring device **100**.

[0082] It is desirable that PCBA **120** is sufficiently rigid to prevent bending and introducing unwanted artifact into the signal. In certain embodiments, an additional mechanism to reduce and prevent unwanted bending of PCBA **120** may be used. This mechanism is shown in FIG. 6B. Support post **460** is integral to lower housing **145** and is positioned directly under patient trigger input **210**. During patient symptom triggering, upper housing member **140** is depressed, engaging inner trigger mechanism **430** and transmitting a force through patient trigger input **210** into PCBA **120**. The force is further transmitted through PCBA **120** and into support post **460** without creating a bending moment, thus avoiding unwanted artifact.

[0083] Referring to FIG. 7, in some embodiments, physiological monitoring device **100** may include one or more additional, optional features. For example, in one embodiment, monitoring device **100** may include a removable liner **810**, a top label **820**, a device identifier **830** and a bottom label **840**. Liner **810** may be applied over a top surface of flexible member **110** to aid in the application of device **100** to the subject. As is described in further detail below, liner

**810** may help support borders **133** of flexible body **110**, as well as wings **130**, **131**, during removal of one or more adhesive covers (not shown) that cover adhesive surface **340** before use. Liner **810** may be relative rigid and/or firm, to help support flexible body **110** during removal of adhesive covers. In various embodiments, for example, liner **810** may be made of cardboard, thick paper, plastic or the like. Liner **810** typically includes an adhesive on one side for adhering to the top surface of wings **130**, **131** of flexible body **110**.

[0084] Labels **820**, **840** may be any suitable labels and may include produce name(s), manufacturer name(s), logo (s), design(s) and/or the like. They may be removably or permanently attached upper housing member **140** and/or lower housing member **145**, although typically they will be permanently attached, to avoid unregulated reuse and/or resale of the device by an unregistered user. Device identifier **830** may be a barcode sticker, computer readable chip, RFID, or the like. Device identifier **830** may be permanently or removably attached to PCBA **120**, flexible body **110** or the like. In some embodiments, it may be beneficial to have device identifier **830** stay with PCBA **120**.

[0085] Referring now to FIGS. **8A** and **8B**, physiological monitoring device **100** generally includes hinge portions **132** at or near the juncture of each wing **130**, **131** with rigid housing **115**. Additionally, each wing **130**, **131** is typically adhered to the patient via adhesive layers **340**, while rigid body **115** is not adhered to the patient and is thus free to “float” (i.e., move up and down) over the patient’s skin during movement and change of patient position. In other words, when the patient’s chest contracts, rigid housing pops up or floats over the skin, thus minimizing stress on device **100**, enhancing comfort, and reducing the tendency of wings **130**, **131** to peel off of the skin. The advantage provided by the combination of the floating rigid body **115** and the adhered wings **130**, **131** is illustrated in FIGS. **8A** and **8B**. In FIG. **8A**, a patient is sleeping, and in FIG. **8B**, a patient is playing golf. In both examples, monitoring device **100** is squeezed together by the patient’s body, causing rigid housing **115** to float above the skin as wings **130**, **131** move closer together. This advantage of a floating, non-attached portion of a physiological monitoring device is described in further detail in U.S. Pat. No. 8,560,046, which was previously incorporated by reference.

[0086] Referring now to FIGS. **9A-9F**, one embodiment of a method for applying physiological monitoring device **100** to the skin of a human subject is described. In this embodiment, before the first step shown in FIG. **9A**, the patient’s skin may be prepared, typically by shaving a small portion of the skin on the left chest where device **100** will be placed and then abrading and/or cleaning the shaved portion. As shown in FIG. **9A**, once the patient’s skin is prepared, a first step of applying device **100** may include removing one or both of two adhesive covers **600** from adhesive layers **340** on the bottom surface of device **100**, thus exposing adhesive layers **340**. As illustrated in FIG. **9B**, the next step may be to apply device **100** to the skin, such that adhesive layer **340** adheres to the skin in a desired location. In some embodiments, one adhesive cover **600** may be removed, the uncovered adhesive layer **340** may be applied to the skin, and then the second adhesive cover **600** may be removed, and the second adhesive layer **340** may be applied to the skin. Alternatively, both adhesive covers **600** may be removed before applying device **100** to the skin. While adhesive covers **600** are being removed, liner **810** acts as a support for

flexible body **110**, provides the physician or other user with something to hold onto, and prevents flexible body **110** and borders **133** of flexible body **110** from folding in on themselves, forming wrinkles, etc. As described above, liner **810** may be made of a relatively stiff, firm material to provide support for flexible body **110** during application of device **100** to the skin. Referring to FIG. **9C**, after device **100** has been applied to the skin, pressure may be applied to flexible body **110** to press it down onto the chest to help ensure adherence of device **100** to the skin.

[0087] In a next step, referring to FIG. **9D**, liner **810** is removed from (peeled off of) the top surface of flexible body **110**. As shown in FIG. **9E**, once liner **810** is removed, pressure may again be applied to flexible body **110** to help ensure it is adhered to the skin. Finally, as shown in FIG. **9F**, upper housing member **140** may be pressed to turn on physiological monitoring device **140**. This described method is only one embodiment. In alternative embodiments, one or more steps may be skipped and/or one or more additional steps may be added.

[0088] When a desired monitoring period has ended, such as about 14-21 days in some cases, a patient (or physician, nurse or the like) may remove physiological monitoring device **100** from the patient’s skin, place device **100** in a prepaid mailing pouch, and mail device **100** to a data processing facility. At this facility, device **100** may be partially or completely disassembled, PCBA **120** may be removed, and stored physiological data, such as continuous heart rhythm information, may be downloaded from PCBA **120**. The data may then be analyzed by any suitable method and then provided to a physician in the form of a report. The physician may then discuss the report with the patient. PCBA **120** and/or other portions of device **100**, such as rigid housing **115**, may be reused in the manufacture of subsequent devices for the same or other patients. Because device **100** is built up as a combination of several removably coupled parts, various parts may be reused for the same embodiment or different embodiments of device **100**. For example, PCBA **120** may be used first in an adult cardiac rhythm monitor and then may be used a second time to construct a monitor for sleep apnea. The same PCBA **120** may additionally or alternatively be used with a differently sized flexible body **110** to construct a pediatric cardiac monitor. Thus, at least some of the component parts of device **100** may be interchangeable and reusable.

[0089] Advantageously, physiological monitoring device **100** may provide long term adhesion to the skin. The combination of the configuration of flexible and conformal body **110**, the watertight, low profile configuration of rigid housing **115**, and the interface between the two allows device **100** to compensate for stress caused as the skin of the subject stretches and bends. As a result, device **100** may be worn continuously, without removal, on a patient for as many as 14-21 days or more. In some cases, device **100** may be worn for greater or less time, but 14-21 days may often be a desirable amount of time for collecting heart rhythm data and/or other physiological signal data from a patient.

[0090] In various alternative embodiments, the shape of a particular physiological monitoring device may vary. The shape, footprint, perimeter or boundary of the device may be circular, an oval, triangular, a compound curve or the like, for example. In some embodiments, the compound curve may include one or more concave curves and one or more convex curves. The convex shapes may be separated by a

concave portion. The concave portion may be between the convex portion on the rigid housing and the convex portion on the electrodes. In some embodiments, the concave portion may correspond at least partially with a hinge, hinge region or area of reduced thickness between the body and a wing.

**[0091]** While described in the context of a heart monitor, the device improvements described herein are not so limited. The improvements described in this application may be applied to any of a wide variety of physiological data monitoring, recording and/or transmitting devices. The improved adhesion design features may also be applied to devices useful in the electronically controlled and/or time released delivery of pharmacological agents or blood testing, such as glucose monitors or other blood testing devices. As such, the description, characteristics and functionality of the components described herein may be modified as needed to include the specific components of a particular application such as electronics, antenna, power supplies or charging connections, data ports or connections for down loading or off loading information from the device, adding or offloading fluids from the device, monitoring or sensing elements such as electrodes, probes or sensors or any other component or components needed in the device specific function. In addition or alternatively, devices described herein may be used to detect, record, or transmit signals or information related to signals generated by a body including but not limited to one or more of ECG, EEG and/or EMG.

**[0092]** While the above embodiments disclose the invention with respect to a data channel for collecting a single physiological signal, it is contemplated that additional data channels can be include to collect additional data, for example, device motion, device flex or bed, heart rate and/or ambient electrical noise.

**[0093]** Various embodiments of a physiological monitoring device and methods for using it have been disclosed above. These various embodiments may be used alone or in combination, and various changes to individual features of the embodiments may be altered, without departing from the scope of the invention. For example, the order of various method steps may in some instances be changed, and/or one or more optional features may be added to or eliminated from a described device. Therefore, the description of the embodiments provided above should not be interpreted as unduly limiting the scope of the invention as it is set forth in the claims.

**[0094]** Various modifications to the implementations described in this disclosure may be made, and the generic principles defined herein may be applied to other implementations without departing from the spirit or scope of this disclosure. Thus, the claims are not intended to be limited to the implementations shown herein, but are to be accorded the widest scope consistent with this disclosure, the principles and the novel features disclosed herein.

**[0095]** Certain features that are described in this specification in the context of separate embodiments also can be implemented in combination in a single embodiment. Conversely, various features that are described in the context of a single embodiment also can be implemented in multiple embodiments separately or in any suitable subcombination. Moreover, although features may be described above as acting in certain combinations and even initially claimed as such, one or more features from a claimed combination can in some cases be excised from the combination, and the

claimed combination may be directed to a subcombination or variation of a subcombination.

**[0096]** Similarly, while operations are depicted in the drawings in a particular order, such operations need not be performed in the particular order shown or in sequential order, or that all illustrated operations be performed, to achieve desirable results. Further, the drawings may schematically depict one more example processes in the form of a flow diagram. However, other operations that are not depicted can be incorporated in the example processes that are schematically illustrated. For example, one or more additional operations can be performed before, after, simultaneously, or between any of the illustrated operations. Moreover, the separation of various system components in the embodiments described above should not be interpreted as requiring such separation in all embodiments. Additionally, other embodiments are within the scope of the following claims. In some cases, the actions recited in the claims can be performed in a different order and still achieve desirable results.

**1-20.** (canceled)

**21.** An electronic device for monitoring physiological signals in a mammal, the device comprising:

- a plurality of flexible wings extending laterally from a rigid housing, each flexible wing configured to conform to a surface of the mammal and comprising a bottom surface comprising a long-term adhesive, the long-term adhesive configured to adhere to the skin of the mammal;

- wherein the plurality of flexible wings comprise a first material and the rigid housing comprises a second material, the second material more rigid than the first material;

- a hardware processor housed within the rigid housing, the rigid housing configured to prevent deformation of the hardware processor in response to movement of the mammal;

- a flexible electrode embedded within each flexible wing, each electrode configured to provide conformal contact with a non-planar surface of the skin of the mammal during movement of the mammal; and

- a plurality of electrode traces extending outward from the rigid housing, each electrode trace conforming to an upper surface of a flexible electrode, the electrode traces and the flexible electrodes configured to remain conformal with the skin of the mammal during bending of the skin.

**22.** The electronic device of claim **21**, wherein each electrode trace conforms to the entire upper surface of a flexible electrode.

**23.** The electronic device of claim **21**, wherein the electrode traces comprise a third material and the flexible electrodes comprise a fourth material, the third material different from the fourth material.

**24.** The electronic device of claim **21**, further comprising a plurality of tabs, each tab extending from the housing and positioned over an electrode trace, wherein each tab is configured to provide strain relief to an electrode trace.

**25.** The electronic device of claim **21**, wherein the plurality of electrode traces are not relied upon for mechanical support.

**26.** The electronic device of claim **21**, wherein the rigid housing comprises a first hook, the first hook configured to

engage a second hook, the second hook attached to a battery holder, the first hook more rigid than the second hook.

27. The electronic device of claim 21, wherein the rigid housing comprises a patient trigger configured to depress and record an instance of a perceived cardiac event, the patient trigger covering a majority of the top surface of the rigid housing.

28. The electronic device of claim 27, further comprising a support post positioned beneath the patient trigger, the support post configured to remain rigid during depression of the patient trigger.

29. The electronic device of claim 21, wherein the long-term adhesive comprises a pressure-sensitive adhesive.

30. The electronic device of claim 21, wherein each electrode trace is positioned between an upper substrate layer and a lower substrate layer.

31. The electronic device of claim 30, wherein the upper substrate layer extends outward beyond the lower substrate layer.

32. The electronic device of claim 21, wherein each wing comprises a rim, the rim thinner than an adjacent portion of the wing and configured to prevent edge-lift of the flexible wing.

33. An electronic device for monitoring physiological signals in a mammal, the device comprising:

a plurality of flexible wings extending laterally from a rigid housing, each flexible wing configured to conform to a surface of the mammal and comprising a bottom surface comprising a long-term adhesive, the long-term adhesive configured to adhere to the skin of the mammal;

wherein each wing comprises an upper substrate layer and a lower substrate layer, the upper substrate layer extending outward from the wing beyond the lower substrate layer, the lower substrate layer and the upper

substrate layer adhered together by a substrate adhesive positioned between the upper substrate layer and the lower substrate layer;

a hardware processor positioned within the housing;

a flexible electrode embedded within each flexible wing, each electrode configured to provide conformal contact with a non-planar surface of the skin of the mammal during movement of the mammal; and

a plurality of electrode traces extending outward from the rigid housing, the electrode traces and the flexible electrodes configured to remain conformal with the skin of the mammal during bending of the skin.

34. The electronic device of claim 33, wherein the housing comprises an upper housing member and a lower housing member, the upper housing member configured to detachably connect to the lower housing member.

35. The electronic device of claim 33, wherein an underside of the housing comprises a plurality of dimples configured to allow airflow between the surface of the mammal and the housing.

36. The electronic device of claim 34, further comprising an upper gasket and a lower gasket positioned between the upper housing member and the lower housing member.

37. The electronic device of claim 33, wherein the hardware processor further comprises spring fingers, the spring fingers configured to provide a reusable electrical connection with a detachable power unit.

38. The electronic device of claim 33, wherein the long-term adhesive is a hydrocolloid.

39. The electronic device of claim 33, wherein the electrode traces extend into the housing.

40. The electronic device of claim 33, wherein the rigid housing comprises a patient trigger configured to depress and record an instance of a perceived cardiac event, the patient trigger covering a majority of the top surface of the rigid housing.

\* \* \* \* \*

专利名称(译)	生理监测装置		
公开(公告)号	<a href="#">US20180289274A1</a>	公开(公告)日	2018-10-11
申请号	US16/006719	申请日	2018-06-12
申请(专利权)人(译)	IRHYTHM TECHNOLOGIES , INC.		
当前申请(专利权)人(译)	IRHYTHM TECHNOLOGIES , INC.		
[标]发明人	BAHNEY TIMOTHY J HO HUNG H PARK SHENA H SEPULVEDA GENARO S DAY MARK J TAMURA YURIKO		
发明人	BAHNEY, TIMOTHY J. HO, HUNG H. PARK, SHENA H. SEPULVEDA, GENARO S. DAY, MARK J. TAMURA, YURIKO		
IPC分类号	A61B5/0408 A61B5/00		
CPC分类号	A61B5/6833 A61B5/0408 A61B5/721 A61B2562/125 A61B2562/0219 A61B2562/164		
优先权	61/756326 2013-01-24 US		
其他公开文献	US10271754		
外部链接	<a href="#">Espacenet</a> <a href="#">USPTO</a>		

摘要(译)

生理监测装置本发明涉及一种生理监测装置。本发明的一些实施例允许长期监测生理信号。进一步的实施例还可以允许监视诸如运动的辅助信号。

