



US 20180213583A1

(19) **United States**

(12) **Patent Application Publication**
Al-Ali

(10) **Pub. No.: US 2018/0213583 A1**

(43) **Pub. Date: Jul. 26, 2018**

(54) **PATIENT-WORN WIRELESS
PHYSIOLOGICAL SENSOR WITH PAIRING
FUNCTIONALITY**

(71) Applicant: **Masimo Corporation**, Irvine, CA (US)

(72) Inventor: **Ammar Al-Ali**, San Juan Capistrano,
CA (US)

(21) Appl. No.: **15/874,652**

(22) Filed: **Jan. 18, 2018**

Related U.S. Application Data

(60) Provisional application No. 62/505,762, filed on May 12, 2017, provisional application No. 62/447,836, filed on Jan. 18, 2017.

Publication Classification

(51) **Int. Cl.**
H04W 76/14 (2006.01)
H04W 8/00 (2006.01)
A61B 5/00 (2006.01)
(52) **U.S. Cl.**
CPC *H04W 76/14* (2018.02); *H04W 4/80*
(2018.02); *A61B 5/0015* (2013.01); *H04W*
8/005 (2013.01)

(57) **ABSTRACT**

Systems and methods described herein use pairing to associate a wireless sensor with a patient monitoring device such as a bedside patient monitor or a mobile device. A signal emitted by a patient monitoring device can be detected by a wireless sensor. The wireless sensor can be associated with the detected signal and pair the wireless sensor with the patient monitoring device. The wireless sensor can be configured to enter into a patient parameter sensing mode of operation after the association of the wireless sensor with the patient monitoring device.

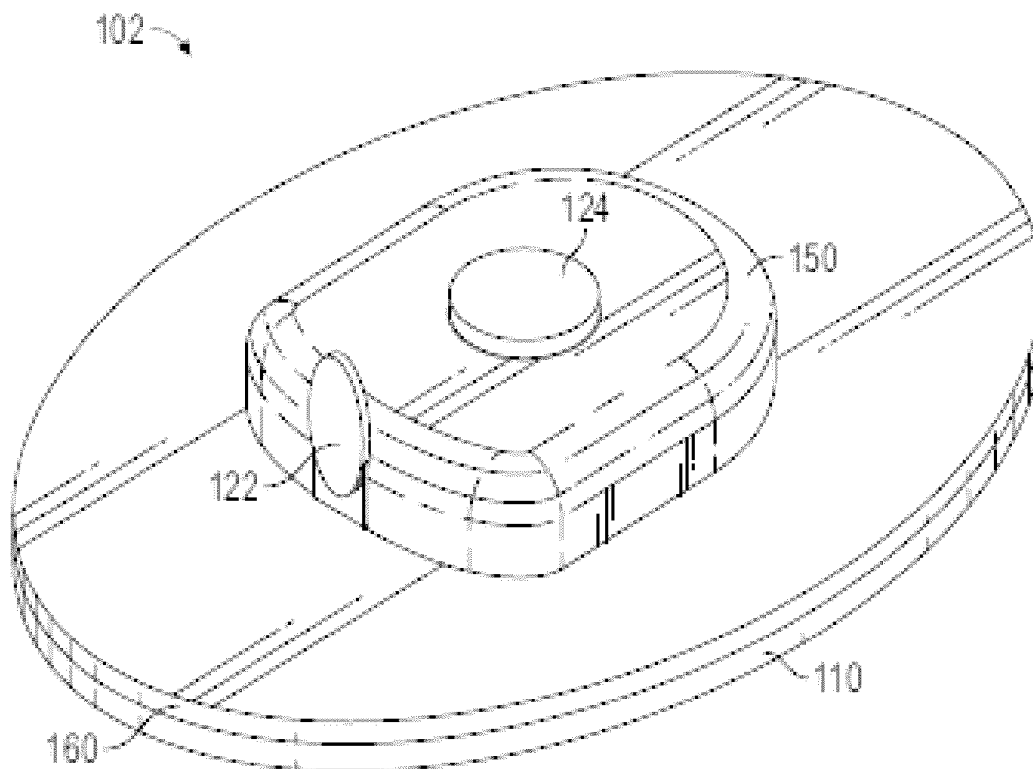

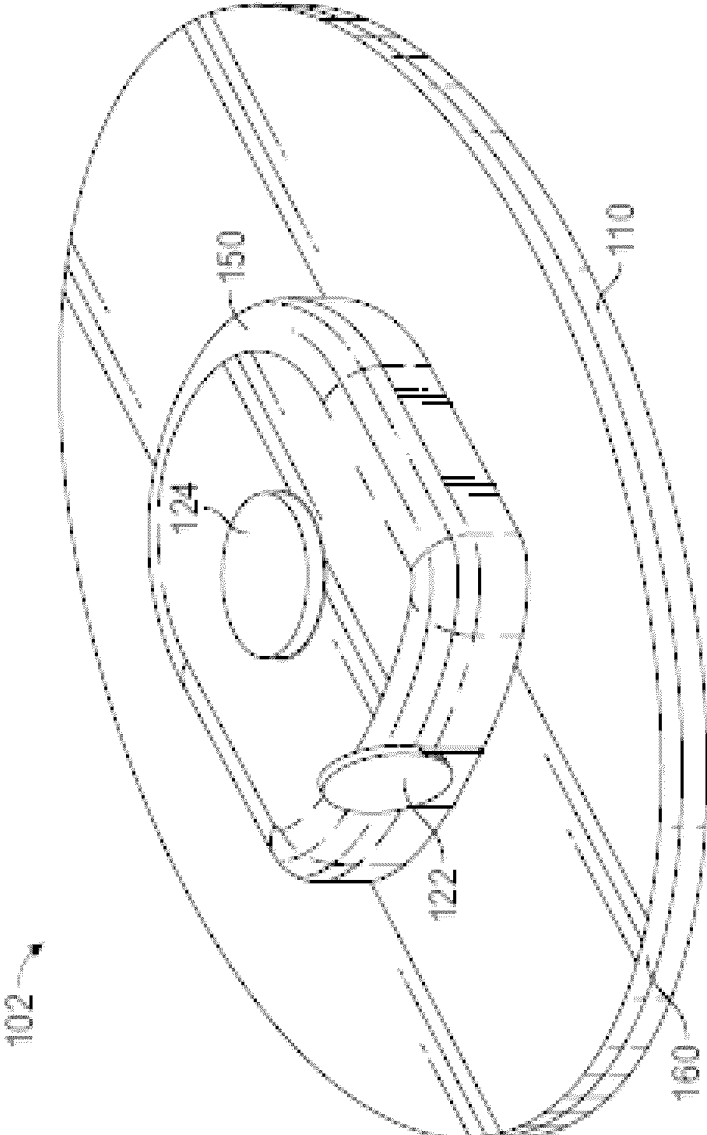

FIG. 1A

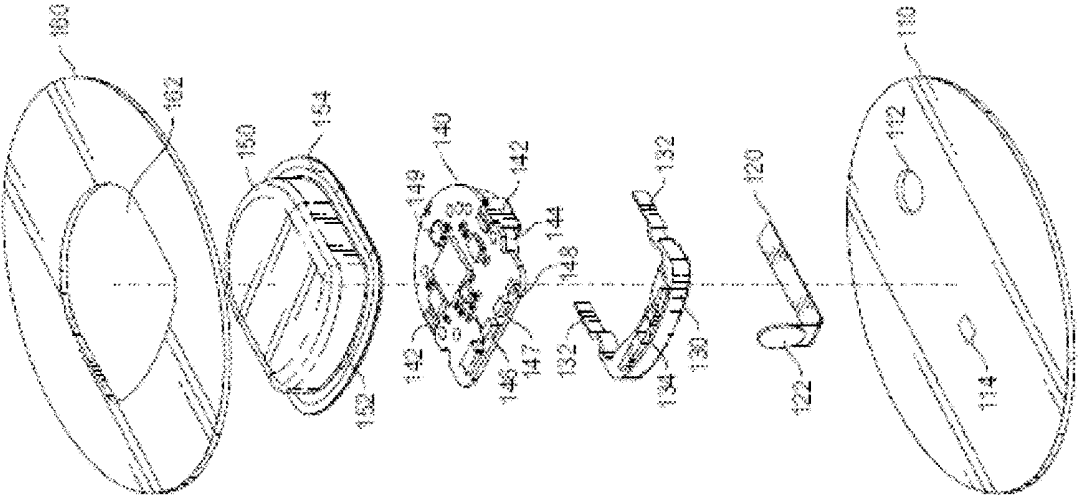

FIG. 1B

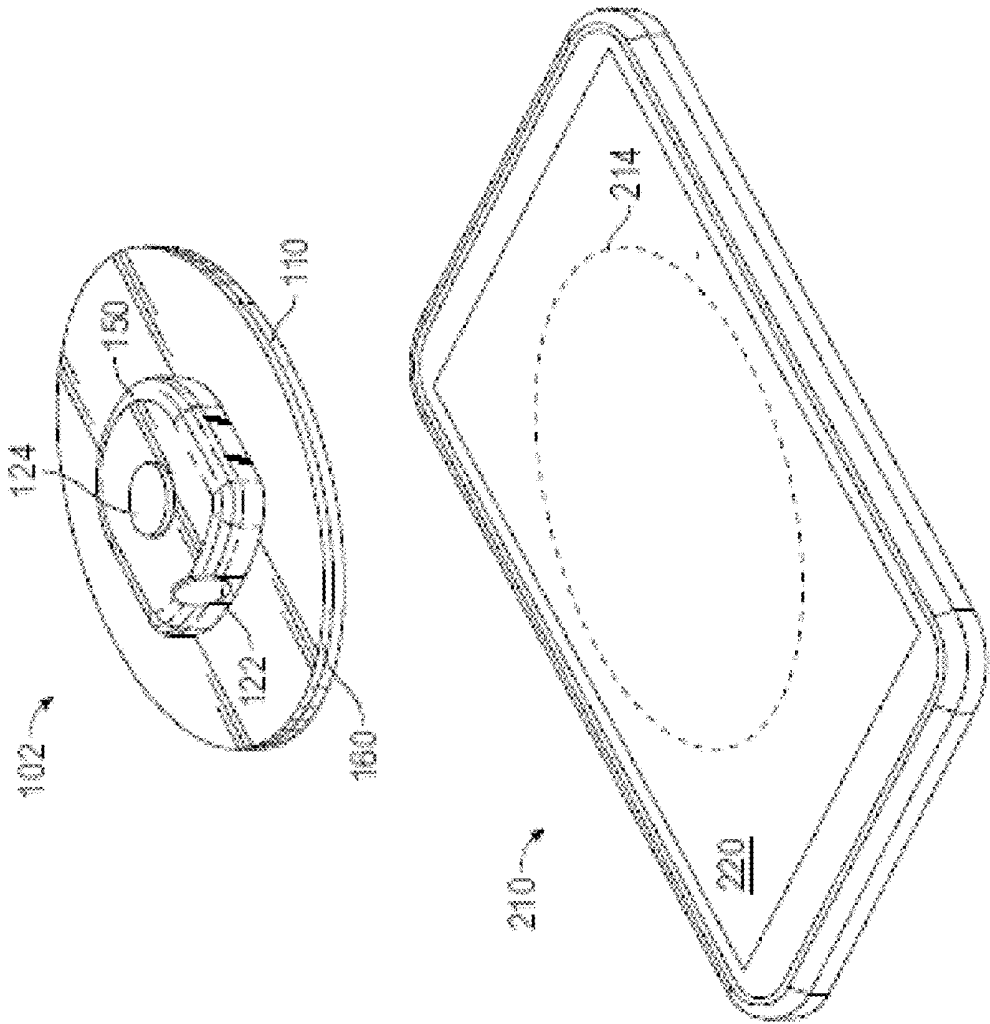

FIG. 2A

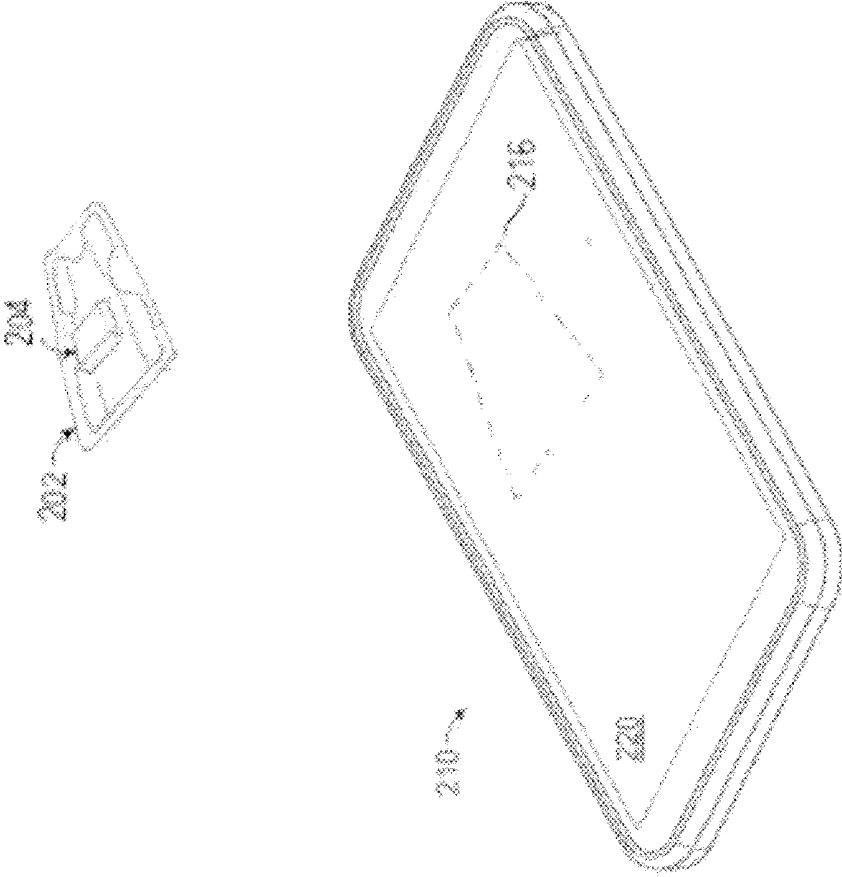

FIG. 2B

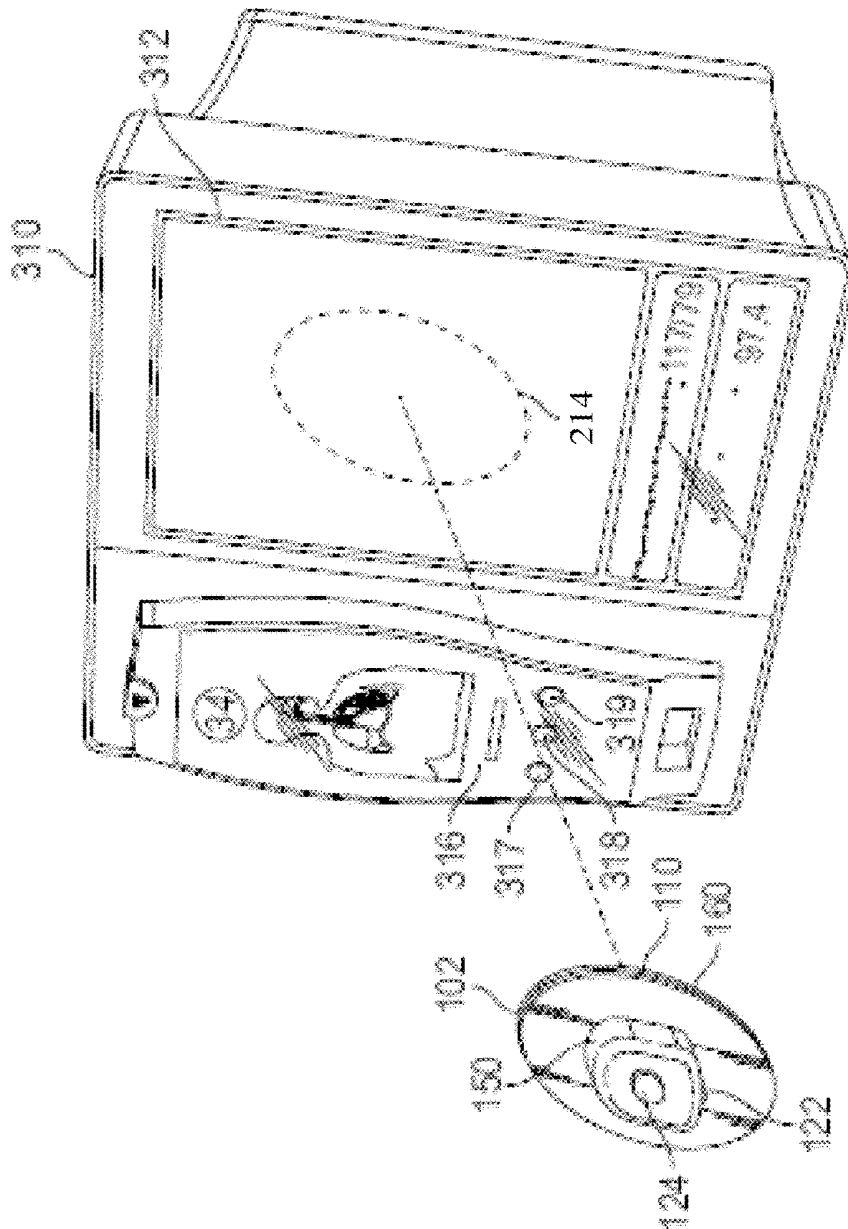

FIG. 3A

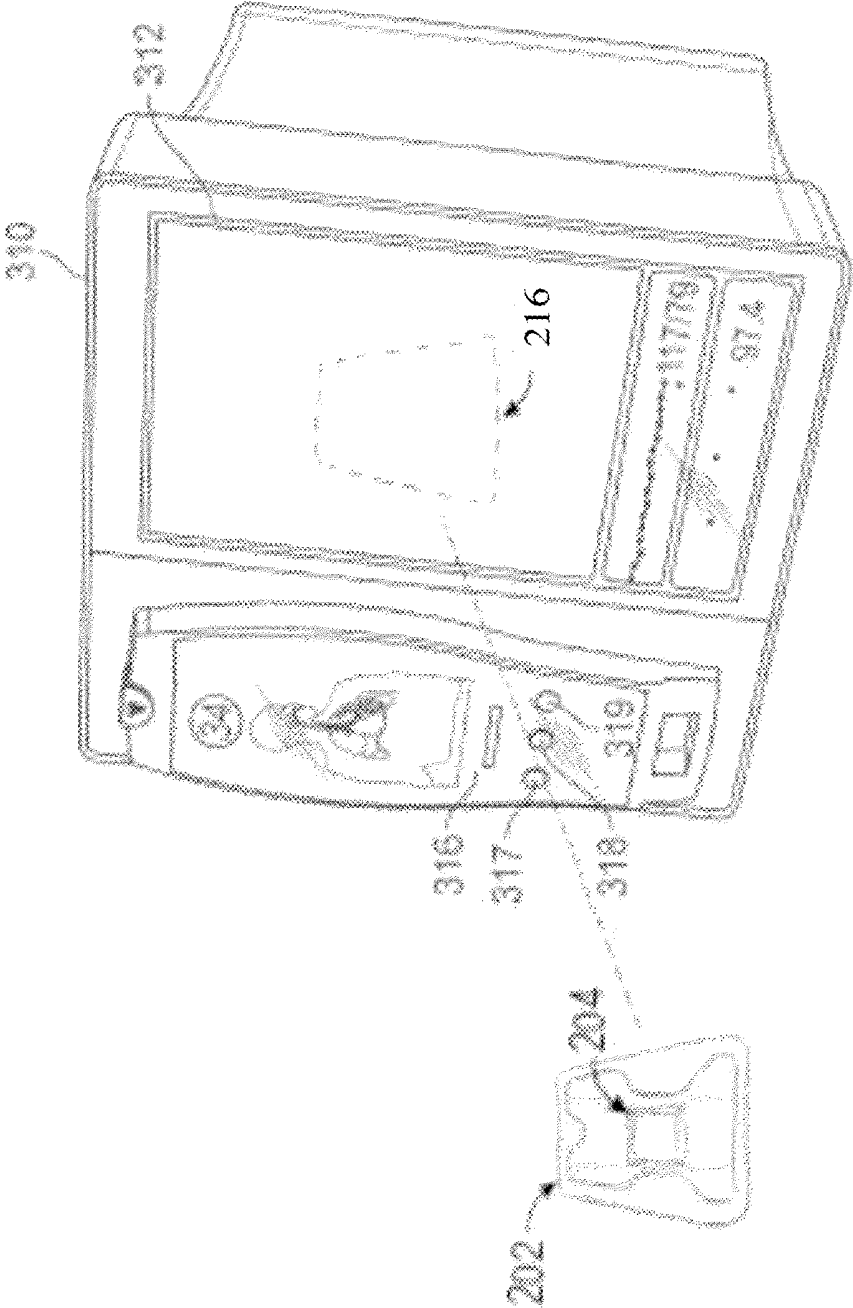

FIG. 3B

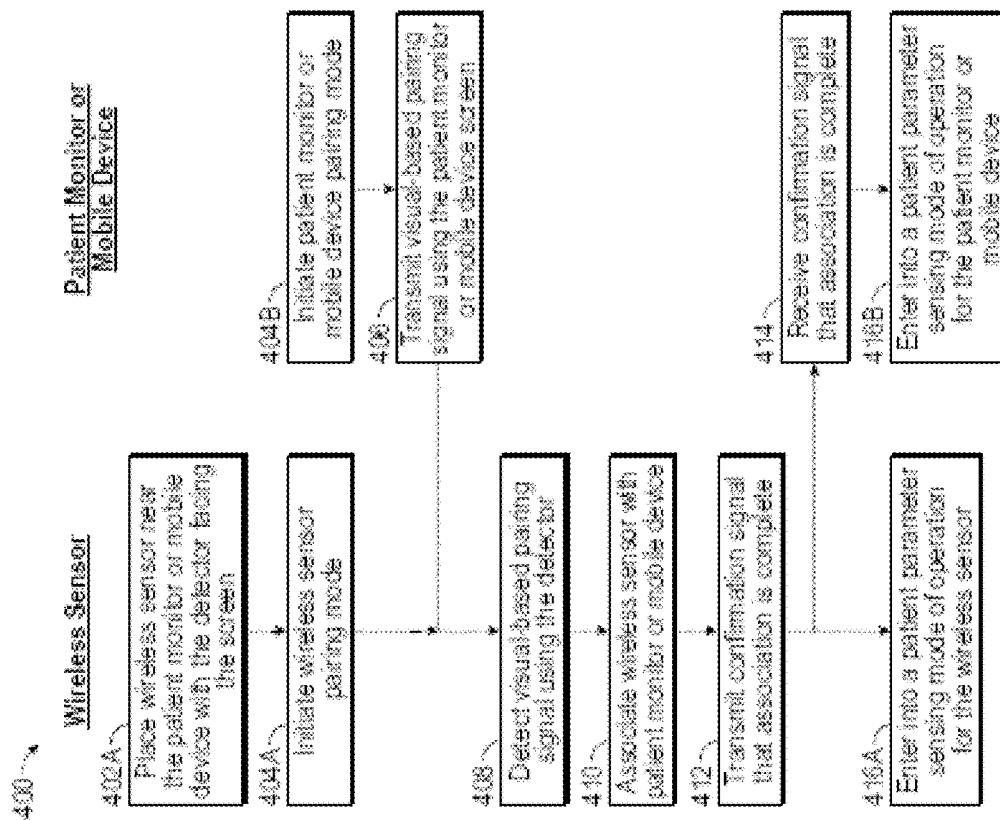

FIG. 4

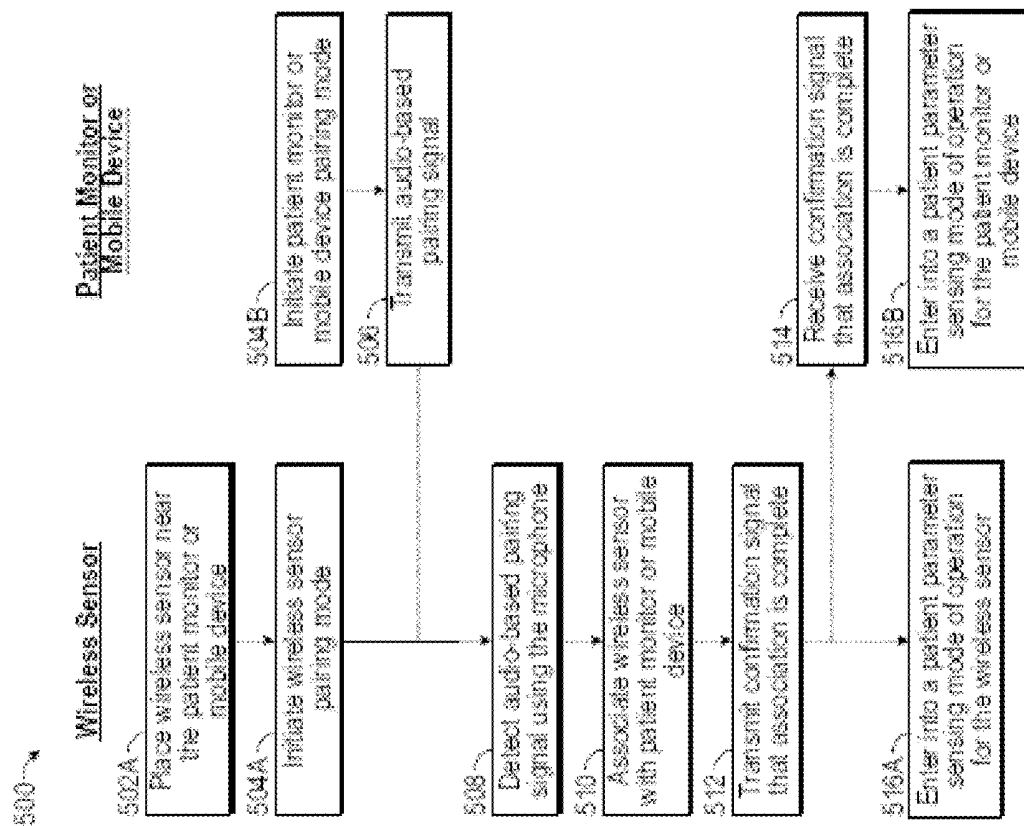

FIG. 5

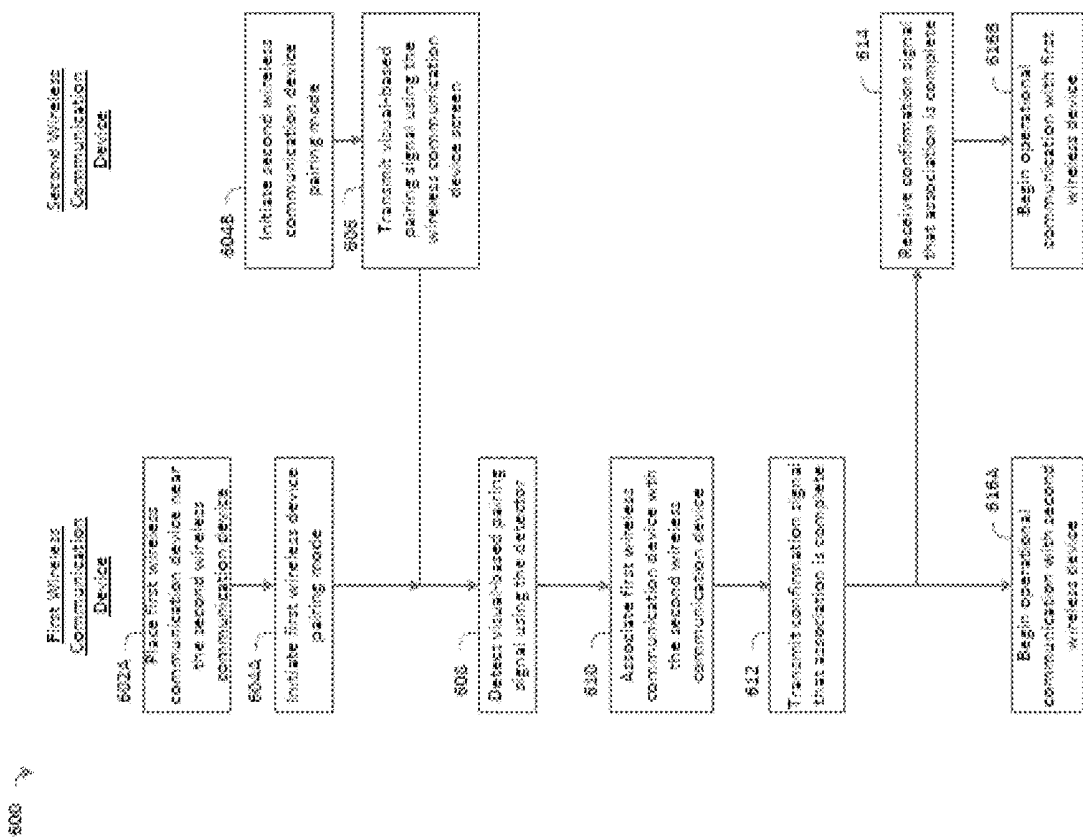

FIG. 6

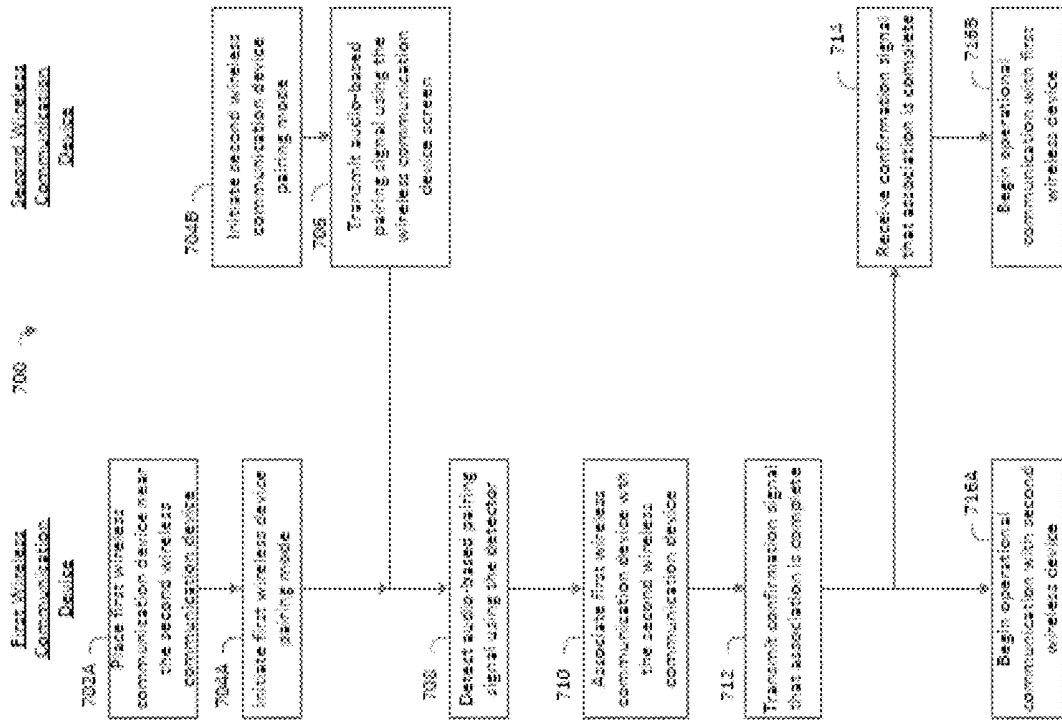

FIG. 7

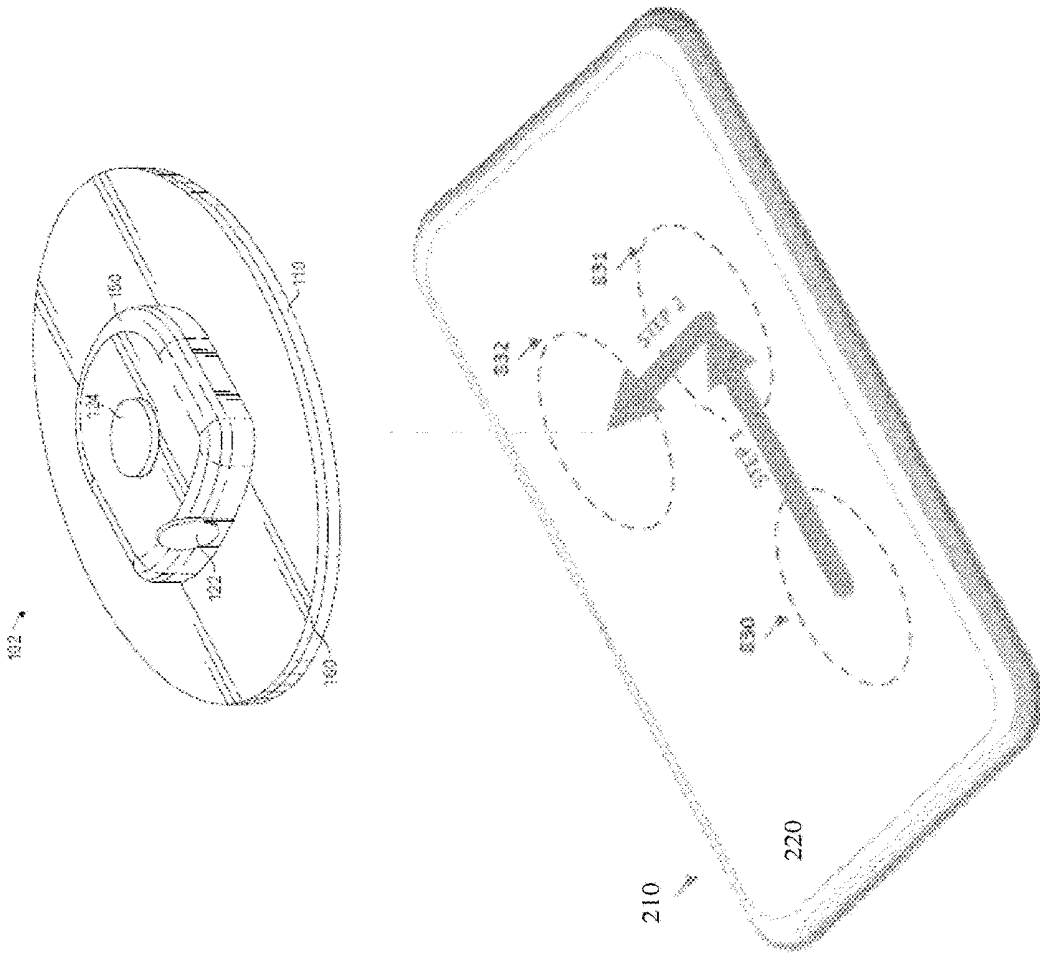

FIG. 8

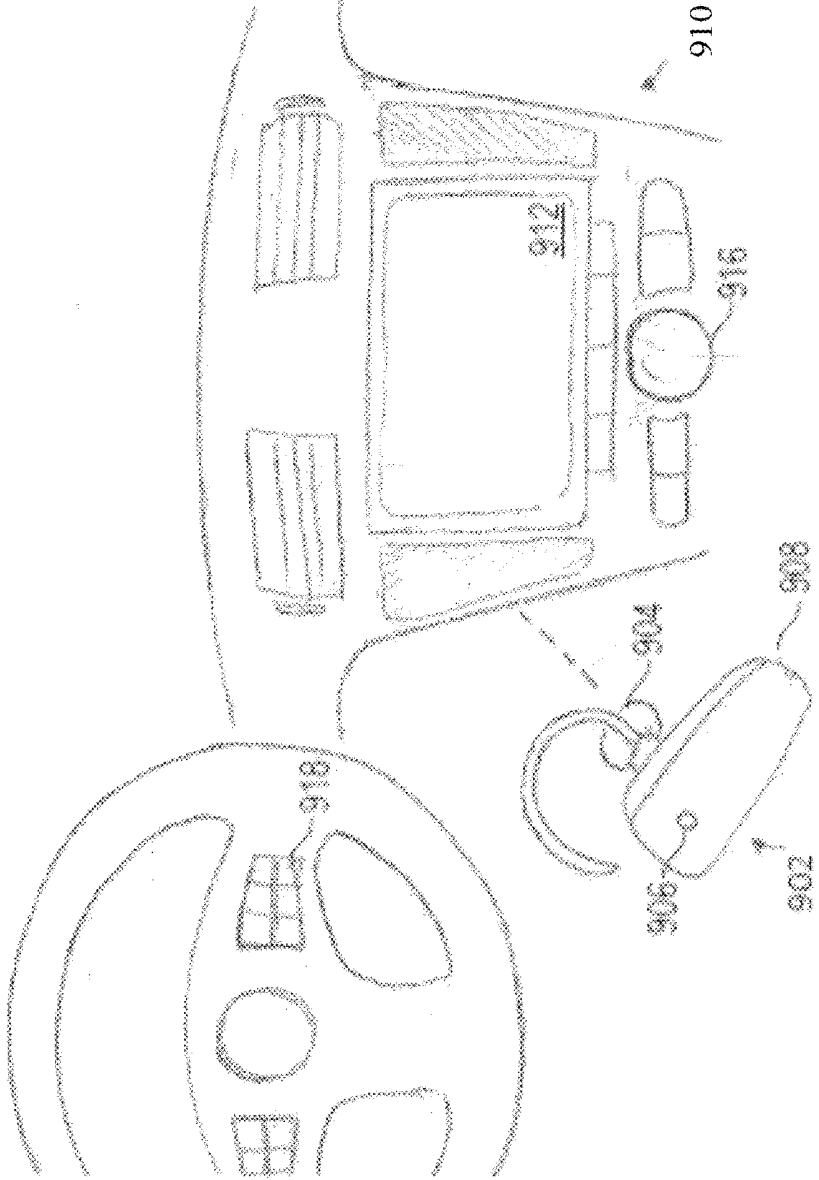

FIG. 9

**PATIENT-WORN WIRELESS
PHYSIOLOGICAL SENSOR WITH PAIRING
FUNCTIONALITY**

RELATED APPLICATIONS

[0001] This application claims priority benefit under 35 U.S.C. § 119(e) from U.S. Provisional Patent Application Ser. No. 62/505,762, filed May 12, 2017, and also claims priority benefit under 35 U.S.C. § 119(e) from U.S. Provisional Patent Application Ser. No. 62/447,836, filed Jan. 18, 2017, titled “PATIENT-WORN WIRELESS PHYSIOLOGICAL SENSOR WITH PAIRING FUNCTIONALITY”, the disclosure of which is hereby incorporated by reference in its entirety.

FIELD OF THE DISCLOSURE

[0002] The present disclosure relates to the field of pairing of wireless communication devices. More specifically, the disclosure describes among other things a portable wireless device that communicates with a second device capable of wireless communication with paired electronic devices.

BACKGROUND

[0003] In clinical settings, such as hospitals, nursing homes, convalescent homes, skilled nursing facilities, post-surgical recovery centers, and the like, patients are frequently monitored using one more different types of physiological sensors. Various types of sensors include a magnetometer that detects patient movement or orientation to track and prevent patient ulcers, a temperature sensor, an acoustic respiration sensor, an electrocardiogram (ECG) sensor, an electroencephalography (EEG) sensor, one or more pulse oximetry sensors, a moisture sensor, a blood pressure sensor, and an impedance sensor, among other sensors.

[0004] Wires leading to and from traditional physiological sensors inhibit patient movement and make it difficult to provide care to a patient. Often sensors are accidentally removed by patient movement. At other times, sensors must be moved or replaced when a patient is moved to a different location or when certain types of care are provided to the patient. Wireless sensors provide a solution to the patient movement and access. However, in busy hospital environments with non-technical staff operating these wireless devices, it can be difficult to correctly configure wireless sensors for communication with the correct monitors.

[0005] Similarly, other wireless devices including consumer devices such as, but not limited to, speakers, phones, headphones, watches, keyboards, mice, and so forth, capable of being paired have similar issues. These devices are often used by non-technically oriented users that encounter cumbersome pairing requirements.

SUMMARY

[0006] For purposes of summarizing the disclosure, certain aspects, advantages and novel features have been described herein. It is to be understood that not necessarily all such advantages can be achieved in accordance with any particular embodiment disclosed herein. Thus, the embodiments disclosed herein can be embodied or carried out in a manner that achieves or optimizes one advantage or group of advantages as taught or suggested herein without necessarily achieving others.

[0007] In certain embodiments, a system for electronically pairing a wireless sensor with a patient monitoring device can include a patient monitoring device, a wireless sensor, and at least one hardware processor. The patient monitoring device can include a first display. The wireless sensor can include a button configured to activate a pairing mode that enables the wireless sensor to electronically pair with the patient monitoring device. The wireless sensor can further comprise an optical detector configured to detect light based signals. The hardware processor can further generate a visual signal from the first display. In some embodiments, the hardware processor can detect the visual signal with the optical detector of the wireless sensor. The hardware processor can associate the wireless sensor with the patient monitoring device based on the detected visual signal, thereby pairing the wireless sensor with the patient monitoring device. The hardware processor can further transmit a confirmation signal from the wireless sensor to indicate that association is complete. The hardware processor can configure the wireless sensor to enter into a patient parameter sensing mode of operation after the association of the wireless sensor with the patient monitoring device.

[0008] The system of the preceding paragraph can have any sub-combination of the following features: where the first display is of a first size and the wireless sensor is of a second size, where the second size of the wireless sensor is smaller than the first size of the first display; where the size of the wireless sensor corresponds to a shape of a base of the wireless sensor; where the wireless sensor does not require a separate antenna or any additional components for the pairing with the patient monitoring device; where the wireless sensor does not use a wireless communication protocol for the pairing with the patient monitoring device; where the wireless sensor does not use a wireless communication protocol including a Bluetooth protocol, wifi protocol, or a zigbee protocol; where the one or more hardware processors are configured to detect a shape of the wireless sensor when the wireless sensor is placed directly on the first display and in response to the detected shape, associate the wireless sensor with the patient monitoring device; and where the one or more hardware processors are configured to generate a pattern on the first display and associate the wireless sensor with the patient monitoring device based on a successful placement of the wireless sensor on the first display in relation to the generated pattern.

[0009] Additionally, in certain embodiments, a system for electronically pairing a wireless sensor with a patient monitoring device can include a patient monitoring device. The system can include a wireless sensor. The wireless sensor can include a button configured to activate a pairing mode that enables the wireless sensor to electronically pair with the patient monitoring device. The system can include one or more hardware processors. The hardware processor can further generate a signal from the patient monitoring device. The hardware processor can also detect the signal with a detector of the wireless sensor. In some embodiments, the hardware processor can associate the wireless sensor with the patient monitoring device based on the detected signal, thereby pairing the wireless sensor with the patient monitoring device. The hardware processor can also transmit a confirmation signal from the wireless sensor to indicate that association is complete. Moreover, the hardware processor can configure the wireless sensor to enter into a patient

parameter sensing mode of operation after the association of the wireless sensor with the patient monitoring device.

[0010] The system of the preceding paragraph can have any sub-combination of the following features: where the wireless sensor does not require a separate antenna or any additional components for the pairing with the patient monitoring device; where the wireless sensor does not use a wireless communication protocol for the pairing with the patient monitoring device; where the detector comprises a piezoelectric element; where the signal comprises an acoustic signal and where the wireless sensor is configured to detect the acoustic signal with the piezoelectric element; and where the detector comprises an optical detector and where the signal comprises a visual signal and the wireless sensor is configured to detect the visual signal with the optical detector.

[0011] In certain embodiments, a method for electronically pairing a wireless sensor with a patient monitoring device can include generating a signal from the patient monitoring device. The method can also include detecting the signal with a detector of the wireless sensor. In some embodiments, the method can include associating the wireless sensor with the patient monitoring device based on the detected signal, thereby pairing the wireless sensor with the patient monitoring device. Furthermore, the method can include transmitting a confirmation signal from the wireless sensor to indicate that association is complete. The method can also include configuring the wireless sensor to enter into a patient parameter sensing mode of operation after the association of the wireless sensor with the patient monitoring device.

[0012] The method of the preceding paragraph can have any sub-combination of the following features: where the wireless sensor does not require a separate antenna or any additional components for the pairing with the patient monitoring device; where the wireless sensor does not use a wireless communication protocol for the pairing with the patient monitoring device; where the detector comprises a piezoelectric element; where the detector comprises an optical detector; further generating a pattern on a first display of the patient monitoring device, where the association is further based on a successful placement of the wireless sensor on the first display in relation to the generated pattern.

BRIEF DESCRIPTION OF THE DRAWINGS

[0013] FIG. 1A is a schematic assembled perspective view of a wireless sensor.

[0014] FIG. 1B is a schematic exploded perspective view of a wireless sensor.

[0015] FIG. 2A is a schematic perspective view of a wireless sensor.

[0016] FIG. 2B is a schematic perspective view of a wireless sensor and a mobile device for pairing.

[0017] FIGS. 3A-3B are perspective views of a wireless sensor and a patient monitor pairing.

[0018] FIG. 4 is a flow diagram describing a process to pair a wireless sensor with a patient monitor.

[0019] FIG. 5 is a flow diagram describing a process to pair a wireless sensor with a patient monitor.

[0020] FIG. 6 is a flow diagram describing a process to pair a first wireless device with a second wireless device.

[0021] FIG. 7 is a flow diagram describing a process to pair a first wireless device with a second wireless device.

[0022] FIG. 8 is a schematic perspective view of the disclosed wireless sensor and a mobile device for pairing.

[0023] FIG. 9 is a schematic perspective view of the disclosed wireless sensor and a car console for pairing.

DETAILED DESCRIPTION

[0024] FIG. 1A is a schematic assembled perspective view of wireless sensor 102. The wireless sensor 102 may also be referred to herein as “a wireless physiological sensor 102,” “a patient-worn sensor 102,” “a movement sensor 102,” and “a wearable wireless sensor 102.” The wireless sensor 102 includes one or more sensors configured to measure the patient’s position, orientation, and motion. Also illustrated in FIG. 1A is a button or switch 124 located on a top portion of the housing 150. The button or switch 124 can be used to change modes of the wireless sensor 102. For example, pressing and holding the button or switch 124 can cause the wireless sensor 102 to switch into a pairing mode of operation. The pairing mode is used to associate the wireless sensor 102 with a mobile device 210 as shown in FIGS. 2A-B or a bedside patient monitor 310 as shown in FIGS. 3A-B. Wireless sensor 102 may include one or more detecting elements such as: a magnetometer which may also be referred to as a compass, a temperature sensor, an acoustic respiration sensor, an electrocardiogram (ECG) sensor, an electroencephalography (EEG) sensor, one or more pulse oximetry sensors, a moisture sensor, a blood pressure sensor, and an impedance sensor.

[0025] The magnetometer may be a three-dimensional magnetometer that provides information indicative of magnetic fields, including the Earth’s magnetic field. A skilled artisan will understand that the accelerometer, gyroscope, and magnetometer can be integrated into a single hardware component such as an inertial measurement unit. The wireless sensor 102 may be configured to calculate the three-dimensional position and orientation of an object derived from inputs from three sensors attached to the object: an accelerometer configured to measure linear acceleration along three axes; a gyroscope configured to measure angular velocity around three axes; and a magnetometer configured to measure the strength of a magnetic field (such as the Earth’s magnetic field) along three axes. The three sensors may attach to the wireless sensor 102 which is affixed to the patient. The sensors may be sampled at a rate between approximately 10 Hz and approximately 100 Hz. One skilled in the art will appreciate that the sensors can be sampled at different rates without deviating from the scope of the present disclosure. The sampled data from the three sensors, which provide nine sensor inputs, are processed to describe the patient’s position and orientation in three-dimensional space. The patient’s position and orientation are described in terms of Euler angles as a set of rotations around a set of X-Y-Z axes of the patient.

[0026] An acoustic respiration sensor can be used to sense acoustic and/or vibrational motion from the patient’s body (e.g., the patient’s chest) that are indicative of various physiologic parameters and/or conditions, including without limitation, heart rate, respiration rate, snoring, coughing, choking, wheezing, and respiratory obstruction (e.g., apneic events). The ECG sensor can be used to measure the patient’s cardiac activity. The ECG sensor may include two electrodes and a single lead. The pulse oximetry sensor(s) can be used to monitor the patient’s pulse oximetry, a widely accepted noninvasive procedure for measuring the oxygen

saturation level of arterial blood, an indicator of a person's oxygen supply. A typical pulse oximetry system utilizes an optical sensor clipped onto a portion of the patient's body (such as, for example, a fingertip, an ear lobe, a nostril, and the like) to measure the relative volume of oxygenated hemoglobin in pulsatile arterial blood flowing within the portion of the body being sensed. Oxygen saturation (SpO₂), pulse rate, a plethysmograph waveform, perfusion index (PI), pleth variability index (PVI), methemoglobin (MetHb), carboxyhemoglobin (CoHb), total hemoglobin (tHb), glucose, and/or otherwise can be measured and monitored using the pulse oximetry sensor(s). The moisture sensor can be used to determine a moisture content of the patient's skin which is a relevant clinical factor in assessing the patient's risk of forming a pressure ulcer. The impedance sensor can be used to track fluid levels of the patient. For example, the impedance sensor can monitor and detect edema, heart failure progression, and sepsis in the patient.

[0027] FIG. 1B is a schematic exploded perspective view of wireless sensor 102 including a bottom base 110, a removable battery isolator 120, a mounting frame 130, a circuit board 140, a housing 150, and a top base 160. The bottom base 110 is a substrate having a top surface on which various components of the wireless sensor 102 are positioned, and a bottom surface that is used to affix the wireless sensor 102 to the patient's body. The bottom base 110 and top base 160 can be made of medical-grade foam material such as white polyethylene, polyurethane, or reticulated polyurethane foams, to name a few. As illustrated in FIG. 1A, the bottom base 110 and the top base 160 are each in a substantially oval shape, with a thickness of approximately 1 mm. The top base 160 includes a cut-out 162 through which the housing 150 fits during assembly. A skilled artisan will understand that there are numerous sizes and shapes suitable for the top and bottom bases 110 and 160 that can be employed without departing from the scope of the present disclosure. The bottom surface of the bottom base 110 is coated with a high tack, medical-grade adhesive, which when applied to the patient's skin, is suitable for long-term monitoring, such as, for example two days or longer. Portions of the top surface of the bottom base 110 are also coated with a medical-grade adhesive, as the bottom base 110 and the top base 160 are adhered together during assembly of the wireless sensor 102. The bottom base 110 may have apertures 112 and 114. These apertures 112 and 114 may permit transmission of thermal energy, electrical energy, light, sound, or any other input to the wireless sensor 102.

[0028] The removable battery isolator 120 is a flexible strip made of an electrically insulating material that serves to block electrical communication between the battery 144 and an electrical contact (not shown) on the circuit board 140. The battery isolator 120 is used to preserve battery power until the wireless sensor 102 is ready for use. The battery isolator 120 blocks electrical connection between the battery 144 and the circuit board 140 until the battery isolator 120 is removed from the wireless sensor 102. The battery isolator 120 can be made of any material that possesses adequate flexibility to be slidably removed from its initial position and adequate dielectric properties so as to electrically isolate the battery 144 from the circuit board 140. For example, the battery isolator 120 can be made of plastic, polymer film, paper, foam, combinations of such materials, or the like. The battery isolator 120 includes a pull

tab 122 that extends through a slot 152 of the housing 150 when the wireless sensor 102 is assembled. The pull tab 122 can be textured to provide a frictional surface to aid in gripping and sliding the pull tab 122 out of its original assembled position. Once the battery isolator 120 is removed the battery 144 makes an electrical connection with the electrical contact to energize the electronic components of the wireless sensor 102.

[0029] The mounting frame 130 is a structural support element that helps secure the battery 144 to the circuit board 140. The mounting frame 130 has wings 132 that, when assembled are slid between battery holder 142 and the battery 144. Additionally, the mounting frame 130 serves to provide rigid structure between the circuit board 140 and the bottom base 110. The rigid structure, which may include an acoustic respiratory sensor, may transmit vibrational motion (vibrations) emanating from the patient (such as, for example, vibrational motions related to respiration, heart-beat, snoring, coughing, choking, wheezing, respiratory obstruction, and the like) to the accelerometer 149 positioned on the circuit board 140. The mounting frame 130 may have an aperture 134 that extends through the mounting frame 130. The aperture 134 may be aligned with the aperture 114 in the bottom base 110 as described above. The aperture 134 may permit transmission of thermal energy, electrical energy, light, sound, or any other input to the wireless sensor 102. The aperture 134 may be filled with a thermally conductive material.

[0030] A battery holder 142 is attached to two sides of the top portion circuit board 140 and extends (forming a support structure) under the bottom side of the circuit board 140 to hold the battery 144 in position relative to the circuit board 140. An electrical connection between the anode of the battery 144 and the circuit board 140 is made by way of the battery holder which is in electrical contact with the anode of the battery 144 and the circuit board 140. The cathode of the battery 144 is positioned to touch a battery contact (not shown) on the bottom side of the circuit board 140.

[0031] The housing 150 is a structural component that serves to contain and protect the components of the wireless sensor 102. The housing 150 can be made of any material that is capable of adequately protecting the electronic components of the wireless sensor 102 such as thermoplastics and thermosetting polymers. The housing 150 includes a slot 152 through which the battery isolator 120 is inserted during assembly. The housing 150 also includes a rim 154 that extends around the outer surface of the housing 150. The rim 154 is used to secure the housing 150 in position relative to the bottom base 110 and the top base 160 when the wireless sensor 102 is assembled.

[0032] Assembly of the wireless sensor 102 is as follows: the circuit board 140 and battery holder 142 holding the battery 144 are placed into the housing 150. The wings 132 of the mounting frame 130 are inserted in between the battery 144 and the battery holder 142, so as to align the mounting frame 130 with the circuit board 140. The battery isolator 120 is positioned between the electrical contact and the battery 144. The pull tab 122 of the battery isolator 120 is then fed through the slot 152 in the housing 150. The top base 160 is then positioned over the housing 150. The rim 154 of the housing 150 adheres to the bottom surface of the top base 160, which is coated with high tack, medical-grade adhesive. The resulting partial assembly is positioned centrally onto the top surface of the bottom base 110, aligning

the edges of the base top 160 with the edges of the base bottom 110. The bottom surface of the bottom base 110 is then coated with a high tack, medical-grade adhesive, and a release liner (not shown) is placed on the bottom surface of the bottom base 110 to protect the adhesive until it is time for use.

[0033] FIG. 2A is a perspective illustration of the patient monitoring system in a clinical setting. The patient monitoring system includes a wireless sensor 102 worn by a patient in proximity to mobile device 210. The mobile device 210 includes screen 220 that may be configured to transmit and receive a visual, optical, and/or light-based pairing signal. The pairing signal may contain a pattern containing a shape, color, or a combination of patterns. The pairing signal may involve displaying instructions on a screen 220 for a user to follow. The instructions may include the user placing a wireless sensor 102 of a particular shape and size in a certain position relative to the screen 220. The instructions may be displayed using an object 214 on the screen 220 to represent the silhouette of the wireless sensor 102. To follow the instructions, the user may hold the wireless sensor 102 and position the wireless sensor 102 according to the instructions. The user may place the wireless sensor 102 to resemble the relative position of the object 214 displayed on the screen 220 of the mobile device 210.

[0034] The pairing signal may contain a series of visual, optical, and/or light based signals. The series of signals may utilize variations in color, shade, shape, or visual patterns. The pairing signal may contain a series of flashes, wherein the flashes may vary in intensity or duration. The pairing signal may comprise a combination of visual and audio signals.

[0035] For example, the wireless sensor 102 and the mobile device 210 may include a detector that detects visual, optical, or light-based signals and another detector for detecting audio sound or a series of audio sounds. A detector may be configured to detect both visual and audio signals. The pairing signal may include a sequence of visual signals that is synchronized with a sequence of audio signals.

[0036] Additionally, the screen 220 may be configured to display motion instructions for a care provider to perform in order to generate motion signals representing a pairing signal. Mobile device 210 may also generate audio-based pairing signals using a speaker (not shown). The sounds may be tuned to a frequency within or outside of the range of human hearing and may comprise various rings or tones. Additionally, the mobile device 210 may have a port for connecting peripheral devices that may generate various signals such as current or voltage based signals. The pairing signal may take the form of an electrical signal.

[0037] FIG. 2B is a perspective illustration of the patient monitoring system in a clinical setting. The patient monitoring system includes a wireless sensor 202 worn by a patient in proximity to mobile device 210. The mobile device 210 includes screen 220 that may be configured to transmit a visual, optical, and/or light-based pairing signal. The pairing signal may contain a pattern containing a shape, color, or a combination of patterns. The pairing signal may involve displaying instructions on a screen 220 for a user to follow. The instructions may include the user placing a wireless sensor 202 of a particular shape and size in a certain position relative to the screen 220. The shape and size of the wireless sensor 202 may differ from the shape and size of the wireless sensor 102. The instructions may be displayed

using an object 216 on the screen 220 to represent the silhouette of the wireless sensor 202. To follow the instructions, the user may hold the wireless sensor 202 and position the wireless sensor 202 according to the instructions. The user may place the wireless sensor 202 to resemble the relative position of the object 216 displayed on the screen 220 of the mobile device 210.

[0038] The pairing signal may contain a series of visual, optical, and/or light based signals. The series of signals may utilize variations in color, shade, shape, or visual patterns. The pairing signal may contain a series of flashes, wherein the flashes may vary in intensity or duration. Mobile device 210 may also generate audio-based pairing signals using a speaker (not shown). The sounds may be tuned to a frequency within or outside of the range of human hearing and may comprise various rings or tones. The pairing signal may comprise a combination of visual and audio signals. For example, the wireless sensor 102 and the mobile device 210 may include a detector that detects visual, optical, or light-based signals and another detector for detecting audio sound or a series of audio sounds. A detector may be configured to detect both visual and audio signals. The pairing signal may include a sequence of visual signals that is synchronized with a sequence of audio signals.

[0039] Additionally, the screen 220 may be configured to display motion instructions for a care provider to perform in order to generate motion signals representing a pairing signal. Additionally, the mobile device 210 may have a port for connecting peripheral devices that may generate various signals such as current or voltage based signals. The pair signal may take the form of an electrical signal.

[0040] Wireless sensor 202 may include a probe for taking non-invasive optical measurements. The probe may have an emitter for transmitting an optical signal and a detector for detecting the optical signal transmitted by the emitter. The probe may have a flexible circuit assembly with circuit paths to connect the emitter and the detector. The detector may be further configured to detect the pairing signal emitted by mobile device 210.

[0041] The wireless sensor 202 may also include a button or switch 204. The button or switch 204 can be used to change modes of the wireless sensor 202. For example, pressing and holding the button or switch 204 can cause the wireless sensor 202 to switch into a pairing mode of operation. The pairing mode is used to associate the wireless sensor 102 with a mobile device 210 or a bedside patient monitor 310.

[0042] FIG. 3A is a perspective illustration of the patient monitoring system in a clinical setting. The patient monitoring system includes a wireless sensor 102 worn by a patient in proximity to a bedside patient monitor 310 located at the side of a patient's bed. The bedside patient monitor 310 may include screen 312 that may be configured to transmit a visual, optical, and/or light-based pairing signal. The pairing signal may contain a pattern containing a shape, color, or a combination of patterns. The pairing signal may involve displaying instructions on a screen 312 for a user to follow.

[0043] The instructions may include the user placing a wireless sensor 102 of a particular shape and size in a certain position relative to the screen 312. The instructions may be displayed using an object 214 on the screen 312 to represent the silhouette of the wireless sensor 102. To follow the instructions, the user may hold the wireless sensor 102 and

position the wireless sensor 102 according to the instructions. The user may place the wireless sensor 102 to resemble the relative position of the object 214 displayed on the screen 312 of the bedside patient monitor 310.

[0044] The pairing signal may contain a series of visual, optical, and/or light based signals. The series of signals may utilize variations in color, shade, shape, or visual patterns. Additionally, the pairing signal may contain a series of flashes, wherein the flashes may vary in intensity or duration. Additionally, the screen 312 may be configured to display motion instructions for a care provider to perform in order to generate motion signals representing a pairing signal. Bedside patient monitor 310 may also generate audio-based pairing signals using a speaker (not shown). The sounds may be tuned to a frequency within or outside of the range of human hearing and may comprise various rings or tones. Additionally, the bedside patient monitor 310 may have a port 316 for connecting peripheral devices that may generate various signals such as current or voltage based signals. The pairing signal may take the form of an electrical signal.

[0045] The patient monitor 310 may have a button or switch 317 can be used to activate the patient monitor 310 and place it in the pairing mode of operation. Similarly the buttons or switches 318, 319 can also be used to activate the patient monitor 310 and place it in the pairing mode of operation. This process is discussed more below. When the button/switch 317 is depressed and/or continuously held down, the patient monitor 310 may enter into the pairing mode of operation.

[0046] FIG. 3B is a perspective illustration of the patient monitoring system in a clinical setting. The patient monitoring system includes a wireless sensor 202 worn by a patient in proximity to a bedside patient monitor 310 located at the side of a patient's bed. The bedside patient monitor 310 may include screen 312 that may be configured to transmit a visual, optical, and/or light-based pairing signal. The pairing signal may contain a pattern containing a shape, color, or a combination of patterns. The pairing signal may involve displaying instructions on a screen 312 for a user to follow.

[0047] Similar to FIG. 3A, the instructions may include the user placing a wireless sensor 202 of a particular shape and size in a certain position relative to the screen 312. The instructions may be displayed using an object 216 on the screen 312 to represent the silhouette of the wireless sensor 202. To follow the instructions, the user may hold the wireless sensor 202 and position the wireless sensor 202 according to the instructions. The user may place the wireless sensor 202 to resemble the relative position of the object 216 displayed on the screen 312 of the bedside patient monitor 310.

[0048] Although described with respect to a bedside patient monitor 310, it is to be understood that mobile device 210 may also perform some or all of the functionality described in relation to bedside patient monitor 310. For example, wireless sensor 102 may pair with either the mobile device 210 or bedside patient monitor 310. Additionally, one skilled in the art will appreciate that numerous types of patient-specific information may be collected and analyzed by either the mobile device 210 or bedside patient monitor 310. Therefore, it is to be understood that patient monitoring system may be implemented with a mobile device 210 or a bedside patient monitor 310.

[0049] In some scenarios, it may be desirable to pair, or associate, the wireless sensor 102 with the bedside patient monitor 310 or mobile device 210 to avoid interference from other wireless devices and/or to associate patient-specific information (stored, for example, on the patient monitor 310) with the sensor data that is being collected and transmitted by the wireless sensor 102. Illustratively, such patient-specific information can include, by way of non-limiting example, the patient's name, age, gender, weight, identification number (e.g., social security number, insurance number, hospital identification number, or the like), admission date, length of stay, physician's name and contact information, diagnoses, type of treatment, perfusion rate, hydration, nutrition, pressure ulcer formation risk assessments, patient turn protocol instructions, treatment plans, lab results, health score assessments, and the like. One skilled in the art will appreciate that numerous types of patient-specific information can be associated with the described patient-worn sensor without departing from the scope of the present disclosure. Additionally, pairing the wireless sensor 102 with the mobile device 210 or bedside patient monitor 310 can be performed to provide data security and to protect patient confidentiality. Some wireless systems require the care provider to program the wireless sensor 102 to communicate with the correct mobile device 210 or bedside patient monitor 310. Other wireless systems require a separate token or encryption key and several steps to pair the wireless device 102 with the correct bedside patient monitors 310. Some systems require the token to be connected to the mobile device 210 or the bedside patient monitor 310, then connected to the wireless device 102, and then reconnected to the mobile device 210 or bedside patient monitor 310. In certain scenarios, it may be desirable to share wireless communication information between a wireless sensor 102 and a mobile device 210 or bedside patient monitor 310 without a separate token or encryption key. For security purposes, it may be desirable to use security tokens to ensure that the correct patient monitor 310 receives the correct wirelessly transmitted data. Security tokens prevent the mobile device 210 or bedside patient monitor 310 from accessing the transmitted data unless the wireless sensor 102 and mobile device 210 or patient monitor 310 share the same password. The password may be a word, passphrase, or an array of randomly chosen bytes.

[0050] FIG. 4 illustrates a method of associating a wireless sensor 102 with a mobile device 210 or a bedside patient monitor 310, which may be referred to as "pairing." At block 402A, the wireless sensor 102 may be placed near the mobile device 210 or the bedside patient monitor 310 in preparation for receiving a pairing signal. A visual, optical, and/or light-based detector 146 of the wireless sensor 102 may be physically oriented and configured to receive a pairing signal in the form of a visual, optical, and/or light-based pairing signal. The pairing signal may contain a pattern containing a shape, color, or a combination of patterns. The pairing signal may contain a series of visual, optical, and/or light based signals. The series of signals may utilize variations in color, shade, shape, or visual patterns. Additionally, the pairing signal may contain a series of flashes, wherein the flashes may vary in intensity or duration. The signal may be unique to the wireless sensor 102 and the mobile device 210 or the bedside patient monitor 310. By using a pairing signal that uniquely identifies the wireless sensor 102 and the mobile device 210 or the bedside

patient monitor **310**, a secure connection may be established between the two paired devices.

[0051] Various types of sensors can be used with the pairing process of the present disclosure. For example, a pulse oximeter sensor can be paired by facing its light detector toward a bedside patient monitor screen **312** or mobile device screen **220** to receive a visual, optical, and/or light based signal. In another example, an ulcer sensor can be paired by receiving a pairing signal in the form of detected motion. Similarly, other types of wireless sensors can be paired using the included detectors. For example, an acoustic sensor can be paired based on audio signals emitted from the patient monitor **310**. EEG and ECG wireless sensors can be paired using small electrical impulses from a special conductor included as part of the patient monitor **310**. Other sensors can be paired in a similar fashion depending on the specific detectors included on the wireless sensors.

[0052] Returning to block **402A**, the wireless sensor **102** may be placed in proximity to the mobile device **210** or the bedside patient monitor **310** such that the visual, optical, and/or light-based detector **146** may receive the visual, optical, and/or light-based pairing signal. The visual, optical, and/or light-based pairing signal may have a pairing signal transmission range of up to approximately three inches. The visual, optical, and/or light-based pairing signal may have a pairing signal transmission range of up to approximately six inches. The visual, optical, and/or light-based pairing signal may have a pairing signal transmission range of up to approximately one foot (i.e., twelve inches) or farther. A skilled artisan will recognize that other ranges can be used for the pairing signal transmission range.

[0053] At block **404A** the wireless sensor **102** is set to operate in a pairing mode. A user may begin by initiating the pairing mode of operation for the wireless sensor **102**. This may include powering on the wireless sensor **102**, switching the wireless sensor **102** to a special pairing state, and/or the like. For example, the wireless sensor **102** may include a battery isolator **120** which, when removed, activates the wireless sensor **102**. Upon activation, the default mode of operation is the pairing mode. The wireless sensor **102** may have a button or switch **124** that can be used to activate the wireless sensor **102** and place it in the pairing mode of operation. For example, a depressible button or switch **124** can be located on the top portion of the housing **150**. When the button or switch **124** is depressed and continuously held down, the wireless sensor **102** enters into the pairing mode of operation and remains in the pairing mode of operation for as long as the button or switch **124** is depressed. The wireless sensor **102** enters into the pairing mode by activating the visual, optical, and/or light-based sensor **146**. Once activated, the optical sensor **146** may be configured to receive the visual, optical, and/or light-based pairing signal. Similarly, the wireless sensor **202** may have a button or switch **204** that can be used to activate the wireless sensor **202** and place it in the pairing mode of operation.

[0054] At block **404B**, the mobile device **210** or bedside patient monitor **310** is set to operate in pairing mode. A user may begin by initiating the pairing mode of operation for the mobile device **210** or the bedside patient monitor **310**. This may include powering on the mobile device **210** or the bedside patient monitor **310**, switching the mobile device **210** or the bedside patient monitor **310** to a special pairing state, and/or the like. The bedside patient monitor **310** may

have a button or switch **317** that can be used to activate the patient monitor **310** and place it in the pairing mode of operation. When the button or switch **317** is depressed and/or continuously held down, the patient monitor **310** enters into the pairing mode of operation. Similarly, the mobile device **210** may have a button or switch that can be used to activate the mobile device **210** and place it in the pairing mode of operation. When the button or switch is depressed and/or continuously held down, the mobile device **210** enters into the pairing mode of operation.

[0055] As reflected at block **406**, the mobile device **210** or the bedside patient monitor **310** transmits a pairing signal to pair, or associate, with wireless sensor **102**. The patient monitor screen **312** or mobile device screen **220** may be configured to emit a pairing signal. The mobile device screen **220** or patient monitor screen **312** may be configured to emit a visual, optical, and/or light-based pairing signal. The pairing signal transmission is received by orienting the visual, optical, and/or light-based detector **146** of the wireless sensor **102** toward the mobile device screen **220** or the patient monitor screen **312**. The limited range of the visual, optical, and/or light-based pairing signal helps to prevent unintended or incidental association of the wireless sensor **102** with a mobile device **210** or bedside patient monitor **310** that might be nearby but which is not intended to be paired with the wireless sensor **102**. Such circumstances can occur in hospitals, healthcare facilities, nursing homes, and the like where wireless sensors **102** mobile devices **210**, and bedside patient monitors **310** are located in close physical proximity to one another.

[0056] At block **408**, the wireless sensor **102** detects the pairing signal from bedside patient monitor **310** or mobile device **210**. Upon detection of the pairing signal, at block **410**, the wireless sensor **102** associates with the bedside patient monitor **310** thereby configuring the wireless sensor **102** and mobile device **210** or the patient monitor **310** to communicate with each other. Once the pairing is completed, the wireless sensor **102** transmits a confirmation signal confirming that the patient-worn sensor **102** is associated with the mobile device **210** or the bedside patient monitor **310**, thereby indicating that the pairing process has been successfully completed, as reflected in block **412**. At block **414**, the mobile device **210** or the bedside patient monitor **310** receives the confirmation signal. And at block **416A**, the wireless sensor **102** exits the pairing mode of operation and enters into a patient parameter sensing mode of operation. Similarly, at block **416B**, the mobile device **210** or the bedside patient monitor **310** enters a patient parameter sensing mode of operation.

[0057] FIG. 5 illustrates a method of associating a wireless sensor **102** with a mobile device **210** or the bedside patient monitor **310**, which may be referred to as "pairing." At block **502A**, the wireless sensor **102** may be placed near the mobile device **210** or the bedside patient monitor **310** in preparation for receiving a pairing signal. For sensors that utilize an audio sensor, such as respirator sensor, the pairing signal may be an audio sound or a series of audio sounds. A sound or audio-based detector **147** of the wireless sensor **102** may be configured to receive a pairing signal in the form of a sound or audio-based pairing signal. The sounds may be tuned to a frequency within or outside of the range of human hearing and may comprise various rings, chimes, or tones. The series of audio sounds may utilize variations in volume or tone to transmit pairing information. The signal may be

unique to the wireless sensor **102** and the mobile device **210** or the patient monitor **310**. By using a pairing signal that uniquely identifies the wireless sensor **102** and the mobile device **210** or the patient monitor **310**, a secure connection may be established between the two paired devices.

[0058] Various types of sensors can be used with the pairing process of the present disclosure. For example, a pulse oximeter sensor can be paired by facing its light detector toward a patient monitor display **312** or mobile device display **220** to receive a visual, optical, and/or light based signal. In another example, an ulcer sensor can be paired by receiving a pairing signal in the form of detected motion. Similarly, other types of wireless sensors can be paired using the included detectors. For example, an acoustic sensor can be paired based on audio signals emitted from the mobile device **210** or the bedside patient monitor **310**. EEG and ECG wireless sensors can be paired using small electrical impulses from a special conductor included as part of the patient monitor **310**. Other sensors can be paired in a similar fashion depending on the specific detectors included on the wireless sensors.

[0059] Returning to block **502A**, the wireless sensor **102** may be placed in proximity to the mobile device **210** or the bedside patient monitor **310** such that the sound or audio detector **147** may receive the sound or audio-based pairing signal. The sound or audio-based pairing signal has a pairing signal transmission range of up to approximately three inches. The sound or audio-based pairing signal may have a pairing signal transmission range of up to approximately six inches. The sound or audio-based pairing signal may have a pairing signal transmission range of up to approximately one foot (i.e., twelve inches) or farther. A skilled artisan will recognize that other ranges can be used for the pairing signal transmission range.

[0060] At block **504A** the wireless sensor **102** is set to operate in a pairing mode. A user may begin by initiating the pairing mode of operation for the wireless sensor **102**. This may include powering on the wireless sensor **102**, switching the wireless sensor **102** to a special pairing state, and/or the like. For example, the wireless sensor **102** may include a battery isolator **120** which, when removed, activates the wireless sensor **102**. Upon activation, the default mode of operation is the pairing mode. The wireless sensor **102** may have a button or switch **124** that can be used to activate the wireless sensor **102** and place it in the pairing mode of operation. For example, a depressible button or switch **124** can be located on the top portion of the housing **150**. When the button or switch **124** is depressed and continuously held down, the wireless sensor **102** enters into the pairing mode of operation and remains in the pairing mode of operation for as long as the button or switch **124** is depressed. The wireless sensor **102** enters into the pairing mode by activating the sound or audio-based sensor **147**. Once activated, the sound or audio-based sensor **147** may be configured to receive the audio or sound-based pairing signal.

[0061] At block **504B**, the mobile device **210** or the bedside patient monitor **310** is set to operate in pairing mode. A user may begin by initiating the pairing mode of operation for the mobile device **210** or the bedside patient monitor **310**. This may include powering on the device, switching the device to a special pairing state, and/or the like. The bedside patient monitor **310** may have a button or switch **317** that can be used to activate the bedside patient monitor **310** and place it in the pairing mode of operation.

When the button or switch **317** is depressed and/or continuously held down, the patient monitor **310** enters into the pairing mode of operation.

[0062] As reflected at block **506**, the mobile device **210** or the bedside patient monitor **310** transmits a pairing signal to pair, or associate, with wireless sensor **102**. The mobile device **210** or the bedside patient monitor **310** is configured to emit a pairing signal. The speaker of the mobile device **210** or the bedside patient monitor **310** may be configured to emit an audio signal or a series of audio sounds as the pairing signal. The pairing signal transmission is received by orienting the audio or sound-based detector **147** of the wireless sensor **102** toward the bedside patient monitor **310** or mobile device **210**. The limited range of the audio or sound-based pairing signal helps to prevent unintended or incidental association of the wireless sensor **102** with a mobile device or bedside patient monitor **310** that might be nearby but which is not intended to be paired with the wireless sensor **102**. Such circumstances can occur in hospitals, healthcare facilities, nursing homes, and the like where wireless sensors **102** and the mobile device **210** or the bedside patient monitor **310** are located in close physical proximity to one another.

[0063] At block **508**, the wireless sensor **102** detects the pairing signal from the mobile device **210** or the patient monitor **310**. Upon detection of the pairing signal, the wireless sensor **102**, at block **510**, associates with the mobile device **210** or the bedside patient monitor **310** thereby configuring the wireless sensor **102** and patient monitor **310** to communicate with each other. Once the pairing is completed, the wireless sensor **102** transmits a confirmation signal confirming that the patient-worn sensor **102** is associated with the mobile device **210** or the bedside patient monitor **310**, thereby indicating that the pairing process has been successfully completed, as reflected in block **512**. At block **514**, the mobile device **210** or the bedside patient monitor **310** receives the confirmation signal. And at block **516A**, the wireless sensor **102** exits the pairing mode of operation and enters into a patient parameter sensing mode of operation. Similarly, at block **516B**, the mobile device **210** or the bedside patient monitor **310** enters a patient parameter sensing mode of operation. In the patient parameter sensing mode of operation, the patient-worn sensor **102** transmits a patient parameter sensing signal having a patient parameter sensing signal transmission range. The wireless sensor **102** increases the power of the patient parameter sensing signal transmission range to a standard operating range, such as for example, approximately three meters. The patient parameter sensing signal transmission range may be approximately ten feet. Alternatively, the patient parameter sensing signal transmission range may be approximately thirty feet. The pairing signal transmission range may be between approximately three and twelve inches, while the patient parameter sensing signal transmission range may be approximately ten feet. There may be at least an order of magnitude difference between the pairing signal transmission range and the patient parameter sensing signal transmission range. Thus, the pairing signal transmission range is substantially less than the patient parameter sensing transmission range. Once the wireless sensor **102** enters into the patient parameter sensing mode of operation, the wireless sensor **102** is then in condition to be placed on the patient to perform sensing and monitoring functions.

[0064] The patient monitor **310** may access the patient's health records and clinician input via a data network. Illustratively, the patients' positional history data, analyzed in view of the patient's health records, may reveal or suggest a treatment protocol) that will likely yield favorable clinical outcomes for the particular patient. Accordingly, the mobile device **210** or the bedside patient monitor **310** analyzes the accessed information in conjunction with the received information from the wireless sensor **102** to determine a recommended treatment protocol for the patient.

[0065] In another aspect of the present disclosure, the mobile device **210** or the bedside patient monitor **310** can determine a score that describes the patient's wellness/sickness state, which may also be referred to as a "Halo Index." Illustratively, the patient monitor **310** accesses and analyzes the patient's health records, clinician input, positional history data provided by the wireless sensor, surface structure pressure data, and other physiological parameter data collected and provided by the wireless sensor (such as, by way of non-limiting example, the patient's temperature, respiration rate, heart rate, ECG signal, and the like) to assess the patient's overall health condition.

[0066] An extender/repeater may be used to communicate with the wireless sensor **102** instead of the mobile device **210** or the bedside patient monitor **310**. Pairing with the extender/repeater may be performed in the same manner described above with respect to FIG. **4** or FIG. **5**.

[0067] In another aspect of the present disclosure, the pairing procedures may be applicable to user products including phones, tablets, headphones, watches, speakers, computer mice, computer keyboards, wearable devices, audio headsets, virtual reality headsets, augmented reality headsets, vehicle consoles, infotainment systems, and any other wireless communication devices known to those of skill in the art.

[0068] The wireless communication device may be a mobile phone. The mobile phone may allow voice calls to establish a data connection using a cellular network or Wi-Fi network. The mobile phone may also include features in the operating system or mobile applications that offer various functionalities for the user. The wireless communication device may be configured to collect various data such as the GPS location of the mobile phone. The mobile applications may be configured to receive collected data from wireless devices that are paired with the mobile phone.

[0069] The wireless communication device may be a wireless headphone that emits audio signals from an audio source. The audio signal may be transmitted through a wireless data connection established using the disclosed pairing procedures. The wireless communication device may be a watch, headset, or other wear device. The device may provide functionality such as detecting the location, movement, physical activity, or physiological condition of the user. The detected data may be transmitted to another wireless device for display, storage, analysis, or other uses. The transmission of the detected data may be facilitated by a wireless data connection established using the disclosed pairing procedures. A wireless data connection may be established to facilitate the use of wireless communication device such as a wireless keyboard or wireless computer mouse. The wireless communication device may be connected to another wireless communication device such as a desktop computer or mobile device such as a laptop or tablet. The transmission of data associated with the func-

tionality of the wireless communication device may be facilitated by a wireless data connection established using the disclosed pairing procedures.

[0070] The wireless communication device may be a vehicle console or infotainment system. The vehicle console or infotainment system may include a screen for displaying the operation of the vehicle. The screen may be a touch screen that functions as a control interface for the vehicle. The console or infotainment system may receive data such as an audio signal, video signal, GPS location, driving directions, or fare calculations from a paired wireless communication device. A skilled artisan would recognize that other data may be exchanged between the vehicle console or infotainment system and a paired wireless communication device. The transmission of data associated with the functionality of the wireless communication device and vehicle console or infotainment system may be facilitated by a wireless data connection established using the disclosed pairing procedures.

[0071] FIG. **6** illustrates a method of associating a first wireless device with a second wireless device, which may be referred to as "pairing." The first wireless device may be a wireless sensor **102** or **202** as described above. The second wireless device may be a mobile device **210** or bedside patient monitor **310** as described above. At block **602A**, the first wireless device may be placed near the second wireless device in preparation for receiving a pairing signal. A visual, optical, and/or light-based detector **146** of the first wireless communication device may be physically oriented and configured to receive a pairing signal in the form of a visual, optical, and/or light-based pairing signal. The pairing signal may contain a pattern containing a shape, color, or a combination of patterns. The pairing signal may contain a series of visual, optical, and/or light based signals. The series of signals may utilize variations in color, shade, shape, or visual patterns. The pairing signal may contain a series of flashes, wherein the flashes may vary in intensity or duration. The signal may be unique to the first wireless device and/or the second wireless device. By using a pairing signal that uniquely identifies the first wireless device and/or the second wireless device, a secure connection may be established between the two paired devices.

[0072] Various types of sensors can be used with the pairing process of the present disclosure. For example, a pulse oximeter sensor can be paired by facing its light detector toward the display or screen of second wireless communication device to receive a visual, optical, and/or light based signal. In another example, an ulcer sensor can be paired by receiving a pairing signal in the form of detected motion. Similarly, other types of wireless sensors can be paired using the already included detectors that are used for physiological detection or other detection of the surrounding environment during normal use. For example, an acoustic sensor can be paired based on audio signals emitted from the second wireless communications device. EEG and ECG wireless sensors can be paired using small electrical impulses from a special conductor included as part of the second wireless communications device. Other sensors can be paired in a similar fashion depending on the specific detectors included on the first wireless communication device.

[0073] Returning to block **602A**, the first wireless device may be placed in proximity to the second wireless device such that the visual, optical, and/or light-based detector **146**

may receive the visual, optical, and/or light-based pairing signal. The visual, optical, and/or light-based pairing signal has a pairing signal transmission range of up to approximately three inches. The visual, optical, and/or light-based pairing signal has a pairing signal transmission range of up to approximately six inches. The visual, optical, and/or light-based pairing signal has a pairing signal transmission range of up to approximately one foot (i.e., twelve inches) or farther. A skilled artisan will recognize that other ranges can be used for the pairing signal transmission range.

[0074] At block 604A the first wireless device is set to operate in a pairing mode. A user may begin by initiating the pairing mode of operation for the first wireless device. This may include powering on the first wireless device, switching the first wireless device to a special pairing state, and/or the like. For example, the first wireless device may include a battery isolator 120 which, when removed, activates the first wireless device. Upon activation, the default mode of operation is the pairing mode. The first wireless device may have a button/switch 124 that can be used to activate the first wireless device and place it in the pairing mode of operation. For example, a depressible button/switch 124 can be located on the top portion of the housing 150. When the button/switch 124 is depressed and continuously held down, the first wireless device enters into the pairing mode of operation and remains in the pairing mode of operation for as long as the button/switch 124 is depressed. The first wireless device may enter into the pairing mode by activating the sound or audio-based sensor 147. Once activated, the sound or audio-based sensor 147 may be configured to receive the audio or sound-based pairing signal.

[0075] At block 604B, the second wireless device is set to operate in pairing mode. A user may begin by initiating the pairing mode of operation for the second wireless device. This may include powering on the device, switching the device to a special pairing state, and/or the like. The second wireless device may have a button or switch that can be used to activate the second wireless device and place it in the pairing mode of operation. When the button or switch is depressed or continuously held down, the second wireless device enters into the pairing mode of operation.

[0076] As reflected at block 606, the second wireless device transmits a pairing signal to pair, or associate, with first wireless device. The second wireless communications device may be configured to emit a pairing signal. The display or screen of the second wireless communication device may be configured to emit a visual, optical, and/or light-based pairing signal. The pairing signal transmission is received by orienting the visual, optical, and/or light-based detector 146 of the first wireless communication device toward the display or screen. The limited range of the visual, optical, and/or light-based pairing signal helps to prevent unintended or incidental association of the first wireless communication device with a second wireless communication device that might be nearby but which is not intended to be paired with the first wireless communication device. Such circumstances can occur in residential buildings, office buildings, commercial facilities, airports, public transportation facilities, hospitals, healthcare facilities, nursing homes, and the like where the first wireless communications device and second communications device are located in close physical proximity to one another.

[0077] At block 608, the first wireless device detects the pairing signal from second wireless device. Upon detection

of the pairing signal, the first wireless device, at block 610, associates with the second wireless device thereby configuring the first wireless device and second wireless device to communicate with each other. Once the pairing is completed, the first wireless device transmits a confirmation signal confirming that the first wireless communication device is associated with the second wireless device, thereby indicating that the pairing process has been successfully completed, as reflected in block 612. At block 614, the second wireless device receives the confirmation signal. And at block 616A, the first wireless device exits the pairing mode of operation and enters into a patient parameter sensing mode of operation. Similarly, at block 616B, the second wireless device enters a patient parameter sensing mode of operation.

[0078] FIG. 7 illustrates another method of associating a first wireless device with a second wireless device, which may be referred to as "pairing." The first wireless device may be a wireless sensor 102 or 202 as described above. The second wireless device may be a mobile device 210 or a bedside patient monitor 310 as described above.

[0079] At block 702A, the first wireless device may be placed near the second wireless device in preparation for receiving a pairing signal. For sensors that utilize an audio sensor, such as respirator sensor, the pairing signal may be an audio sound or a series of audio sounds. A sound or audio-based detector 147 of the first wireless device may be configured to receive a pairing signal in the form of a sound or audio-based pairing signal. The sounds may be tuned to a frequency within or outside of the range of human hearing and may comprise various rings, chimes, or tones. The series of audio sounds may utilize variations in volume or tone to transmit pairing information. The signal may be unique to the first wireless device and/or the second wireless device. By using a pairing signal that uniquely identifies the first wireless device and/or the second wireless device, a secure connection may be established between the two paired devices.

[0080] Various types of sensors can be used with the pairing process of the present disclosure. For example, a pulse oximeter sensor can be paired by facing its light detector toward the display or screen of a second wireless communication device to receive a visual, optical, and/or light based signal. In another example, an ulcer sensor can be paired by receiving a pairing signal in the form of detected motion. Similarly, other types of wireless sensors can be paired using the included detectors. For example, an acoustic sensor can be paired based on audio signals emitted from the second wireless communications device. EEG and ECG wireless sensors can be paired using small electrical impulses from a special conductor included as part of the second wireless communications device. Other sensors can be paired in a similar fashion depending on the specific detectors included on the first wireless communication device.

[0081] Returning to block 702A, the first wireless device may be placed in proximity to the second wireless communications device such that the sound or audio detector may receive the sound or audio-based pairing signal. The sound or audio-based pairing signal may have a pairing signal transmission range of up to approximately three inches. The sound or audio-based pairing signal has a pairing signal transmission range of up to approximately six inches. The sound or audio-based pairing signal may have a pairing

signal transmission range of up to approximately one foot (i.e., twelve inches) or farther. A skilled artisan will recognize that other ranges can be used for the pairing signal transmission range.

[0082] At block 704A the first wireless device is set to operate in a pairing mode. A user may begin by initiating the pairing mode of operation for the first wireless device. This may include powering on the first wireless device, switching the first wireless device to a special pairing state, and/or the like. For example, the first wireless device may include a battery isolator 120 which, when removed, activates the first wireless device. Upon activation, the default mode of operation is the pairing mode. The first wireless device may have a button/switch 124 that can be used to activate the first wireless device and place it in the pairing mode of operation. For example, a depressible button/switch 124 can be located on the top portion of the housing 150. When the button/switch 124 is depressed and continuously held down, the first wireless device enters into the pairing mode of operation and remains in the pairing mode of operation for as long as the button or switch 124 is depressed. The wireless sensor can be placed in pairing mode by being shaken, bounced, or by shining a bright light at the detector. The first wireless device enters into the pairing mode by activating the sound or audio-based sensor 147. Once activated, the sound or audio-based sensor 147 may be configured to receive the audio or sound-based pairing signal.

[0083] At block 704B, the second wireless device is set to operate in pairing mode. A user may begin by initiating the pairing mode of operation for the second wireless device. This may include powering on the device, switching the device to a special pairing state, and/or the like. The second wireless device may have a button/switch that can be used to activate the second wireless device and place it in the pairing mode of operation. When the button/switch is depressed and/or continuously held down, the second wireless device enters into the pairing mode of operation.

[0084] As reflected at block 706, the second wireless device transmits a pairing signal to pair, or associate, with first wireless device. The second wireless communications device may be configured to emit a pairing signal. The speaker of the second wireless communications device may be configured to emit an audio signal or a series of audio sounds as the pairing signal. The pairing signal transmission is received by orienting the audio or sound-based detector 147 of the first wireless device toward the second wireless communications device. The limited range of the audio or sound-based pairing signal helps to prevent unintended or incidental association of the first wireless device with a second wireless device that might be nearby but which is not intended to be paired with the first wireless device. Such circumstances can occur in residential buildings, office buildings, commercial facilities, airports, public transportation facilities, hospitals, healthcare facilities, nursing homes, and the like where the first wireless communications device and second communications device are located in close physical proximity to one another.

[0085] At block 708, the first wireless device detects the pairing signal from second wireless device. Upon detection of the pairing signal, the first wireless device, at block 710, associates with the second wireless device thereby configuring the first wireless device and second wireless device to communicate with each other. Once the pairing is completed, the first wireless device transmits a confirmation

signal confirming that the first wireless communication device is associated with the second wireless device, thereby indicating that the pairing process has been successfully completed, as reflected in block 712. At block 714, the second wireless device receives the confirmation signal. And at block 716A, the first wireless device exits the pairing mode of operation and enters into a patient parameter sensing mode of operation. Similarly, at block 716B, the second wireless device enters a patient parameter sensing mode of operation.

[0086] FIG. 8 illustrates a method of associating a wireless sensor 102 with a wireless communication device 810, which may be referred to as "pairing." A wireless sensor 102 may include a motion sensor. The wireless communication device 810 may include a device screen 820. Here, the pairing signal may involve displaying instructions on device screen 820 for a user to follow. The instructions may indicate steps that a user must follow in order to complete the pairing process. In one example, the instructions may be a sequence of motions that the user must perform on the wireless sensor 802. The instructions may be displayed using objects 830, 831, 832 on device screen 820 representing the silhouette of the wireless sensor 102. The objects 830, 831, 832 are displayed on the device screen 820 in sequence, one at a time, along with an arrow representing the direction the wireless sensor 102 should move. To follow the instructions, the user may hold the wireless sensor 102 and move the position of the wireless sensor 102 according to the instructions. For example, to complete STEP 1 of the pairing instruction, the user will move the wireless sensor 102 in an upward motion relative to the device screen 820. The change in position of first wireless communication device 820 will resemble the relative change in position from object 830 to object 831 on the device screen 820. To complete STEP 2 of the pairing instruction, the user will move the wireless sensor 102 in a leftward motion relative to the device screen 820. The change in position of the wireless communication device 820 will resemble the relative change in position from object 831 to object 832 on the device screen 820. The motion detector of the wireless communication device 810 detects each step of the motion. The detected motion is then used as the pairing signal to associate the wireless sensor 102 with wireless communication device 810. One skilled in the art will appreciate that other types and sequences of motion may be used as the pairing signal.

[0087] FIG. 9 illustrates a method of associating a first wireless communication device with a second wireless communication device. The first wireless communication device may be a bluetooth headset 902. The wireless communication device may be a vehicle console or infotainment system 910. The vehicle console or infotainment system 910 may include a screen 912 for displaying information related to the operation of the vehicle and control interface. The console or infotainment system 910 may receive data such as an audio signal, video signal, GPS location, driving directions, or fare calculations from a paired wireless communication device from a first wireless communication device 902. A skilled artisan would recognize that other data may be exchanged between the vehicle console or infotainment system and a paired wireless communication device.

[0088] The transmission of data associated with the functionality of the wireless communication device 902 and vehicle console or infotainment system 910 may be facilitated by a wireless data connection established using a

pairing procedure. The pairing procedure may include using a pairing signal to associate the first wireless communication device 902 with vehicle console or infotainment system 910. The pairing signal may contain a pattern containing a shape, color, or a combination of patterns. The pairing signal may contain a series of visual, optical, and/or light based signals. The series of signals may utilize variations in color, shade, shape, or visual patterns. The pairing signal may contain a series of flashes, wherein the flashes may vary in intensity or duration. The wireless communication device 902 may have a light 906 that emits various visual or light based signals. Similarly, the wireless communication device 902 may include a speaker 908 that may generate audio-based pairing signals. The sounds may be tuned to a frequency within or outside of the range of human hearing and may comprise various rings or tones. The pairing signal may comprise a combination of visual signals emitted from wireless communication device light 906 and audio signals emitted from wireless communication device speaker 908. The pairing signal may include a sequence of visual signals emitted from console screen 912 that is synchronized with a sequence of audio signals emitted from console speaker. Additionally, the wireless communication device 902 may have a speaker 904 configured to be placed in the user's ear. The speaker 904 or the speaker 908 may transmit a confirmatory signal that the device has been successfully paired.

[0089] The pairing process may be similar to the methods described above. The screen 912 of the vehicle console or infotainment system 910. The pairing signal may involve displaying instructions on the screen 912 for a user to follow. The instructions may include placing a wireless communication device 902 of a particular shape and size in a certain position relative to the screen 912. The user may follow the instructions and hold the wireless communication device 902 in a certain position relative to the screen 912 to pair the wireless communication device 902 to the vehicle console or infotainment system 910.

[0090] Additionally, the console screen 912 may be configured to display motion instructions for a user to perform in order to generate motion signals representing a pairing signal. Additionally, the console or infotainment system 910 may have a port for connecting peripheral devices that may generate various signals such as current or voltage based signals. The pair signal may take the form of an electrical signal.

[0091] The vehicle console or infotainment system 910 can have a switch or button 916 which, when depressed, places the wireless communication device 902 in a pairing mode of operation, causing the wireless communication device 902 to wait for a pairing signal. Similarly, the vehicle console or infotainment system 910 can have a switch or button 918 on the steering wheel which, when depressed, places the wireless communication device 902 in a pairing mode of operation, causing the wireless communication device 902 to wait for a pairing signal.

[0092] Many other variations than those described herein will be apparent from this disclosure. For example, certain acts, events, or functions of any of the algorithms described herein can be performed in a different sequence, can be added, merged, or left out altogether (e.g., not all described acts or events are necessary for the practice of the algorithms). Moreover, acts or events can be performed concurrently, e.g., through multi-threaded processing, interrupt processing, or multiple processors or processor cores or on

other parallel architectures, rather than sequentially. In addition, different tasks or processes can be performed by different machines and/or computing systems that can function together.

[0093] The first wireless communication device and second wireless communication device may be paired without additional components. The first wireless communication may be a wireless sensor. The wireless sensor may be a variety of sensors as described herein, such as a magnetometer which may also be referred to as a compass, a temperature sensor, an acoustic respiration sensor, an electrocardiogram (ECG) sensor, an electroencephalography (EEG) sensor, one or more pulse oximetry sensors, a moisture sensor, a blood pressure sensor, and an impedance sensor. The second wireless communication device may be a mobile device 210 or a bedside patient monitor 310. Similarly, a variety of wireless sensors described herein may be paired to a wireless communication device such as a mobile device or a patient monitoring system. Further, the wireless communication device may also other devices such as phones, tablets, headphones, watches, speakers, computer mice, computer keyboards, wearable devices, audio headsets, virtual reality headsets, augmented reality headsets, vehicle consoles, infotainment systems, and any other wireless communication devices known to those of skill in the art.

[0094] The methods and systems described herein can be implemented without any additional hardware components. There is no installation of additional components required. This can provide ease of use and implementation such that users can use devices they are familiar with without additional components. For example, as described above, the shape of the device may be used as a pairing signal. In another example, the vibration of an acoustic sensor may be used as a pairing signal. The properties of the sensors or wireless communication devices can be utilized in the pairing process by the system and methods described herein.

[0095] The methods and systems for pairing described herein can also be implemented without the use of wireless communication protocols. For example, the pairing methods and systems can be implemented without the use of protocols such as a Bluetooth protocol, a wifi protocol, or a zigbee protocol.

[0096] The various illustrative logical blocks, modules, and algorithm steps described in connection with the disclosure herein can be implemented as electronic hardware, computer software, or combinations of both. To clearly illustrate this interchangeability of hardware and software, various illustrative components, blocks, modules, and steps have been described above generally in terms of their functionality. Whether such functionality is implemented as hardware or software depends upon the particular application and design constraints imposed on the overall system. The described functionality can be implemented in varying ways for each particular application, but such implementation decisions should not be interpreted as causing a departure from the scope of the disclosure.

[0097] The various illustrative logical blocks and modules described in connection with the disclosure herein can be implemented or performed by a machine, such as a general purpose processor, a digital signal processor (DSP), an application specific integrated circuit (ASIC), a field programmable gate array (FPGA) or other programmable logic device, discrete gate or transistor logic, discrete hardware components, or any combination thereof designed to per-

form the functions described herein. A general purpose processor can be a microprocessor, but in the alternative, the processor can be a controller, microcontroller, or state machine, combinations of the same, or the like. A processor can include electrical circuitry configured to process computer-executable instructions. A processor may include an FPGA or other programmable device that performs logic operations without processing computer-executable instructions. A processor can also be implemented as a combination of computing devices, e.g., a combination of a DSP and a microprocessor, a plurality of microprocessors, one or more microprocessors in conjunction with a DSP core, or any other such configuration. A computing environment can include any type of computer system, including, but not limited to, a computer system based on a microprocessor, a mainframe computer, a digital signal processor, a portable computing device, a device controller, or a computational engine within an appliance, to name a few.

[0098] The steps of a method, process, or algorithm described in connection with the disclosure herein can be embodied directly in hardware, in a software module stored in one or more memory devices and executed by one or more processors, or in a combination of the two. A software module can reside in RAM memory, flash memory, ROM memory, EPROM memory, EEPROM memory, registers, hard disk, a removable disk, a CD-ROM, or any other form of non-transitory computer-readable storage medium, media, or physical computer storage known in the art. An example storage medium can be coupled to the processor such that the processor can read information from, and write information to, the storage medium. In the alternative, the storage medium can be integral to the processor. The storage medium can be volatile or nonvolatile. The processor and the storage medium can reside in an ASIC.

[0099] Conditional language used herein, such as, among others, “can,” “might,” “may,” “e.g.,” and the like, unless specifically stated otherwise, or otherwise understood within the context as used, is generally intended to convey that certain examples include, while other examples do not include, certain features, elements and/or states. Thus, such conditional language is not generally intended to imply that features, elements and/or states are in any way required for one or more examples or that one or more examples necessarily include logic for deciding, with or without author input or prompting, whether these features, elements and/or states are included or are to be performed in any particular example. The terms “comprising,” “including,” “having,” and the like are synonymous and are used inclusively, in an open-ended fashion, and do not exclude additional elements, features, acts, operations, and so forth. Also, the term “or” is used in its inclusive sense (and not in its exclusive sense) so that when used, for example, to connect a list of elements, the term “or” means one, some, or all of the elements in the list. Further, the term “each,” as used herein, in addition to having its ordinary meaning, can mean any subset of a set of elements to which the term “each” is applied.

[0100] While the above detailed description has shown, described, and pointed out novel features as applied to various examples, it will be understood that various omissions, substitutions, and changes in the form and details of the systems, devices or methods illustrated can be made without departing from the spirit of the disclosure. As will be recognized, certain examples described herein can be embodied within a form that does not provide all of the

features and benefits set forth herein, as some features can be used or practiced separately from others.

[0101] The term “and/or” herein has its broadest, least limiting meaning which is the disclosure includes A alone, B alone, both A and B together, or A or B alternatively, but does not require both A and B or require one of A or one of B. As used herein, the phrase “at least one of” A, B, “and” C should be construed to mean a logical A or B or C, using a non-exclusive logical or.

[0102] The apparatuses and methods described herein may be implemented by one or more computer programs executed by one or more processors. The computer programs include processor-executable instructions that are stored on a non-transitory tangible computer readable medium. The computer programs may also include stored data. Non-limiting examples of the non-transitory tangible computer readable medium are nonvolatile memory, magnetic storage, and optical storage.

[0103] Although the foregoing disclosure has been described in terms of certain preferred examples, other examples will be apparent to those of ordinary skill in the art from the disclosure herein. Additionally, other combinations, omissions, substitutions and modifications will be apparent to the skilled artisan in view of the disclosure herein. Accordingly, the present invention is not intended to be limited by the description of the preferred examples, but is to be defined by reference to claims.

What is claimed is:

1. A system for electronically pairing a wireless sensor with a patient monitoring device, the system comprising:
 - a patient monitoring device comprising a first display;
 - a wireless sensor, the wireless sensor comprising a button configured to activate a pairing mode that enables the wireless sensor to electronically pair with the patient monitoring device, the wireless sensor further comprising an optical detector configured to detect light based signals; and
 one or more hardware processors configured to:
 - generate a visual signal from the first display;
 - detect the visual signal with the optical detector of the wireless sensor;
 - associate the wireless sensor with the patient monitoring device based on the detected visual signal, thereby pairing the wireless sensor with the patient monitoring device;
 - transmit a confirmation signal from the wireless sensor to indicate that association is complete; and
 - configure the wireless sensor to enter into a patient parameter sensing mode of operation after the association of the wireless sensor with the patient monitoring device.
2. The system of claim 1, wherein the first display is of a first size and the wireless sensor is of a second size, wherein the second size of the wireless sensor is smaller than the first size of the first display.
3. The system of claim 2, wherein the size of the wireless sensor corresponds to a shape of a base of the wireless sensor.
4. The system of claim 1, wherein the wireless sensor does not require a separate antenna or any additional components for the pairing with the patient monitoring device.
5. The system of claim 1, wherein the wireless sensor does not use a wireless communication protocol for the pairing with the patient monitoring device.

6. The system of claim 5, wherein the wireless communication protocol comprises at least one of: a Bluetooth protocol, wifi protocol, or a zigbee protocol.

7. The system of claim 1, wherein the one or more hardware processors are configured to detect a shape of the wireless sensor when the wireless sensor is placed directly on the first display and in response to the detected shape, associate the wireless sensor with the patient monitoring device.

8. The system of claim 1, wherein the one or more hardware processors are configured to generate a pattern on the first display and associate the wireless sensor with the patient monitoring device based on a successful placement of the wireless sensor on the first display in relation to the generated pattern.

9. A system for electronically pairing a wireless sensor with a patient monitoring device, the system comprising:
a patient monitoring device comprising a first display;
a wireless sensor, the wireless sensor comprising a button configured to activate a pairing mode that enables the wireless sensor to electronically pair with the patient monitoring device; and
one or more hardware processors configured to:
generate a signal from the patient monitoring device;
detect the signal with a detector of the wireless sensor;
associate the wireless sensor with the patient monitoring device based on the detected signal, thereby pairing the wireless sensor with the patient monitoring device;
transmit a confirmation signal from the wireless sensor to indicate that association is complete; and
configure the wireless sensor to enter into a patient parameter sensing mode of operation after the association of the wireless sensor with the patient monitoring device.

10. The system of claim 9, wherein the wireless sensor does not require a separate antenna or any additional components for the pairing with the patient monitoring device.

11. The system of claim 9, wherein the wireless sensor does not use a wireless communication protocol for the pairing with the patient monitoring device.

12. The system of claim 9, wherein the detector comprises a piezoelectric element.

13. The system of claim 12, wherein the signal comprises an acoustic signal and wherein the wireless sensor is configured to detect the acoustic signal with the piezoelectric element.

14. The system of claim 9, wherein the detector comprises an optical detector and wherein the signal comprises a visual signal and the wireless sensor is configured to detect the visual signal with the optical detector.

15. A method for electronically pairing a wireless sensor with a patient monitoring device, the method comprising:
generating a signal from the patient monitoring device;
detecting the signal with a detector of the wireless sensor;
associating the wireless sensor with the patient monitoring device based on the detected signal, thereby pairing the wireless sensor with the patient monitoring device;
transmitting a confirmation signal from the wireless sensor to indicate that association is complete; and
configuring the wireless sensor to enter into a patient parameter sensing mode of operation after the association of the wireless sensor with the patient monitoring device.

16. The method of claim 15, wherein the wireless sensor does not require a separate antenna or any additional components for the pairing with the patient monitoring device.

17. The method of claim 15, wherein the wireless sensor does not use a wireless communication protocol for the pairing with the patient monitoring device.

18. The method of claim 15, wherein the detector comprises a piezoelectric element.

19. The method of claim 15, wherein the detector comprises an optical detector.

20. The method of claim 15, further comprising generating a pattern on a first display of the patient monitoring device, wherein the association is further based on a successful placement of the wireless sensor on the first display in relation to the generated pattern.

* * * * *

专利名称(译)	患者佩戴的无线生理传感器具有配对功能		
公开(公告)号	US20180213583A1	公开(公告)日	2018-07-26
申请号	US15/874652	申请日	2018-01-18
[标]申请(专利权)人(译)	梅西莫股份有限公司		
申请(专利权)人(译)	Masimo公司		
当前申请(专利权)人(译)	Masimo公司		
[标]发明人	AL ALI AMMAR		
发明人	AL-ALI, AMMAR		
IPC分类号	H04W76/14 H04W8/00 A61B5/00		
CPC分类号	H04W76/14 H04W8/005 A61B5/0015 H04W4/80 H04W84/20 A61B2562/08		
优先权	62/505762 2017-05-12 US 62/447836 2017-01-18 US		
外部链接	Espacenet USPTO		

摘要(译)

本文描述的系统和方法使用配对来将无线传感器与患者监测设备（例如床边患者监测器或移动设备）相关联。由患者监测设备发出的信号可以由无线传感器检测。无线传感器可以与检测到的信号相关联，并将无线传感器与患者监测设备配对。无线传感器可以被配置为在无线传感器与患者监测设备相关联之后进入患者参数感测操作模式。

