



US 20170273576A1

(19) **United States**

(12) **Patent Application Publication**  
**OZAWA et al.**

(10) **Pub. No.: US 2017/0273576 A1**

(43) **Pub. Date: Sep. 28, 2017**

(54) **LIVING-BODY INFORMATION MEASURING DEVICE**

*A61B 5/0205* (2006.01)

*A61B 5/00* (2006.01)

(71) Applicant: **FUJI XEROX CO., LTD.**, Tokyo (JP)

(52) **U.S. Cl.**

CPC ..... *A61B 5/0261* (2013.01); *A61B 5/7278* (2013.01); *A61B 5/1455* (2013.01); *A61B 5/0205* (2013.01); *A61B 5/7257* (2013.01); *A61B 5/7225* (2013.01); *A61B 2562/0233* (2013.01); *A61B 5/02416* (2013.01)

(72) Inventors: **Hideaki OZAWA**, Kanagawa (JP);  
**Hideyuki UMEKAWA**, Kanagawa (JP);  
**Tomoaki KOJIMA**, Kanagawa (JP);  
**Kazuhiro SAKAI**, Kanagawa (JP);  
**Manabu AKAMATSU**, Kanagawa (JP)

(73) Assignee: **FUJI XEROX CO., LTD.**, Tokyo (JP)

(57)

**ABSTRACT**

(21) Appl. No.: **15/229,206**

A living-body information measuring device includes plural light-emitting elements, a light-receiving element that is disposed at a position at different distances from the light-emitting elements and that receives reflected light beams that are reflected from a living body when the light-emitting elements emit light beams toward the living body, a control unit that controls the light-emitting elements so that the light-emitting elements successively emit the light beams, and a measurement unit that measures living-body information at plural depths in the living body by using the reflected light beams that are successively received by the light-receiving element.

(22) Filed: **Aug. 5, 2016**

(30) **Foreign Application Priority Data**

Mar. 28, 2016 (JP) ..... 2016-064461

**Publication Classification**

(51) **Int. Cl.**

*A61B 5/026* (2006.01)

*A61B 5/1455* (2006.01)

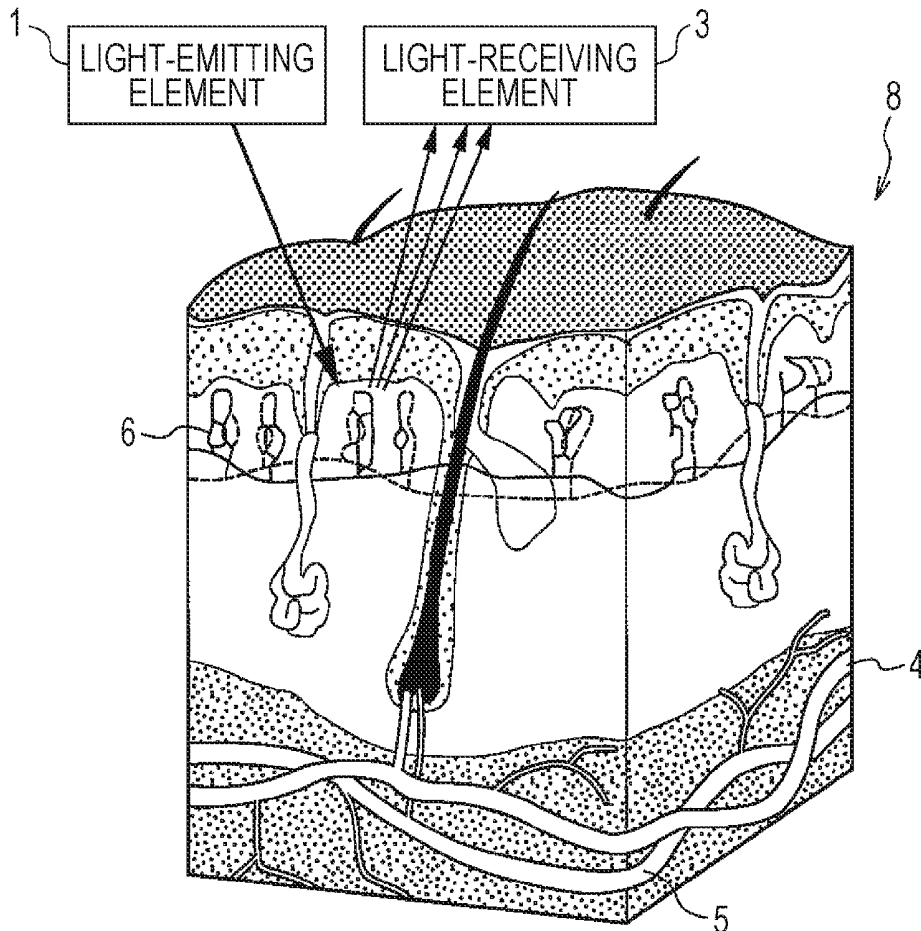

FIG. 1

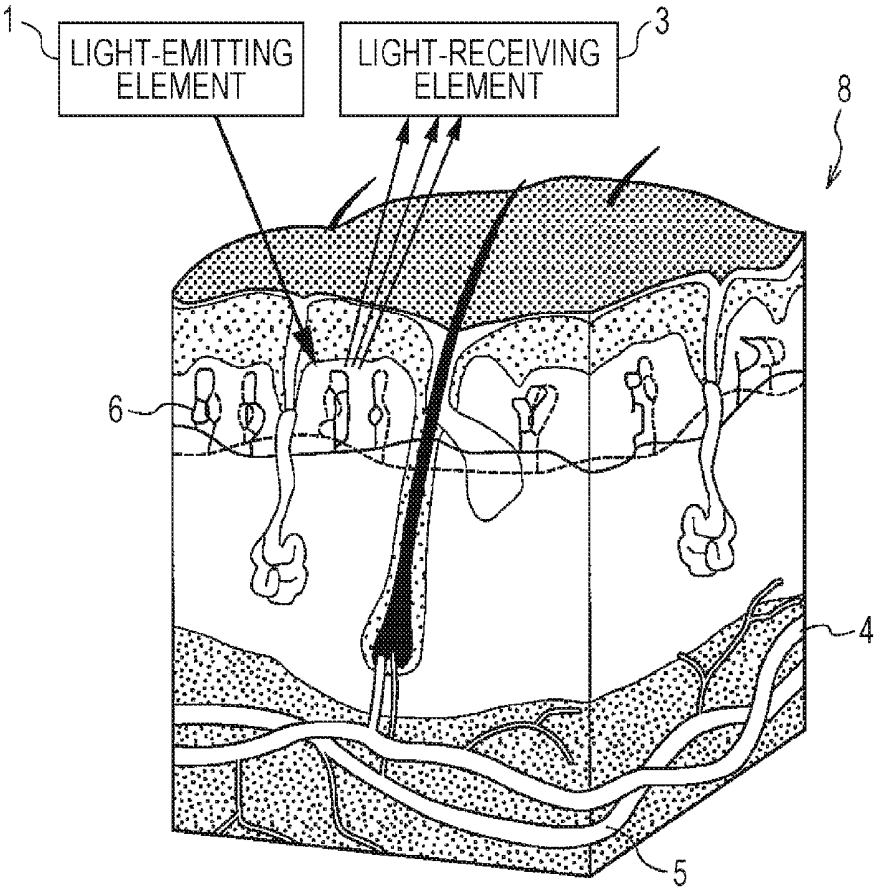

FIG. 2

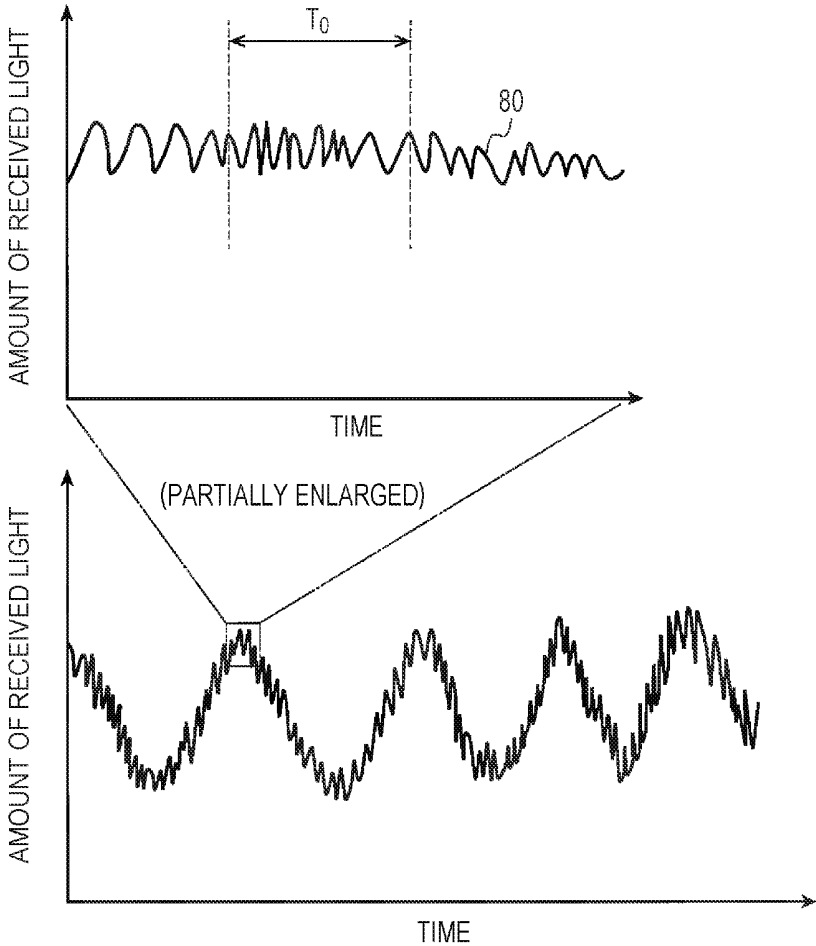

FIG. 3

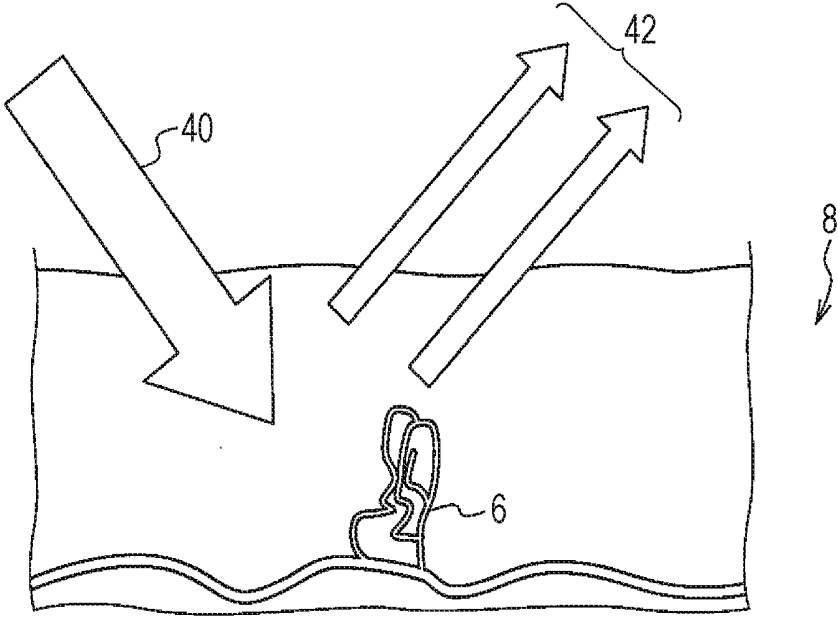

FIG. 4

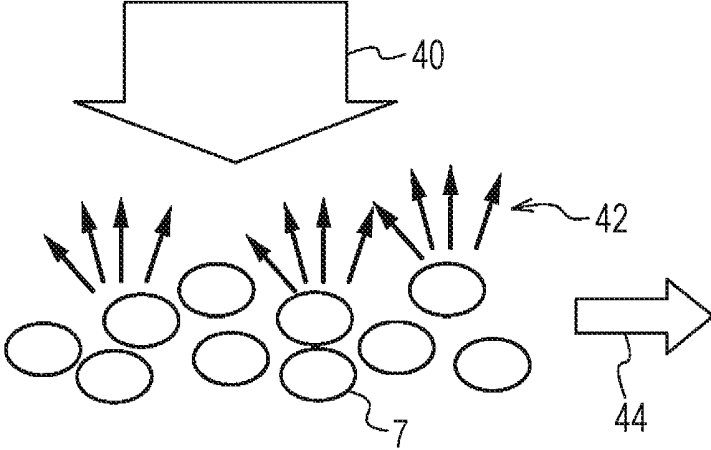

FIG. 5

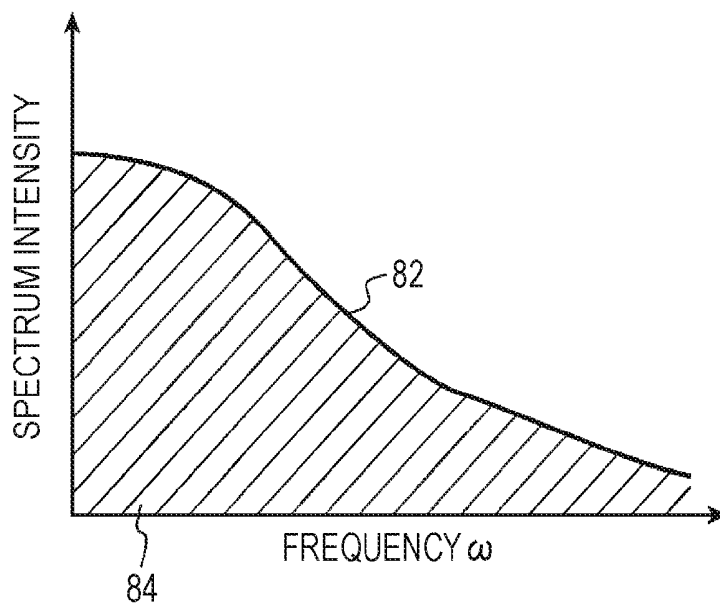

FIG. 6

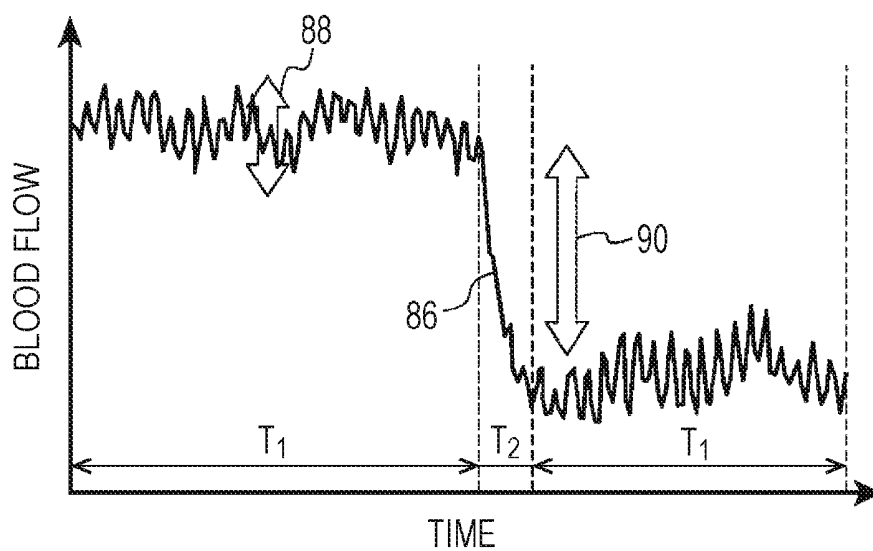

FIG. 7

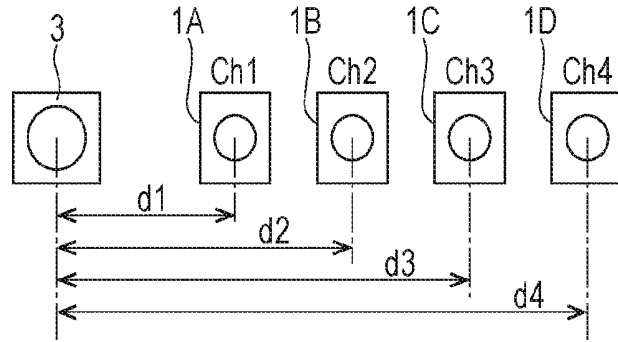

FIG. 8

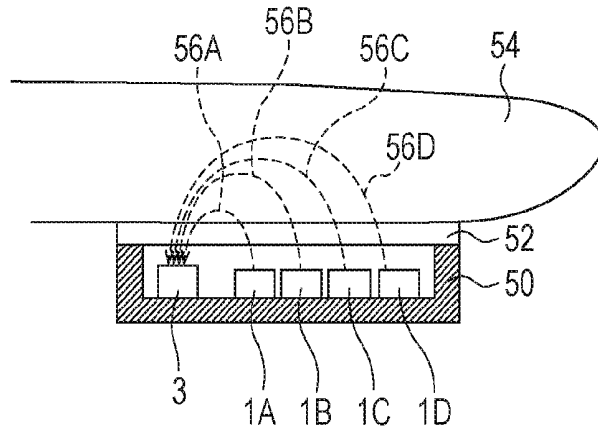

FIG. 9

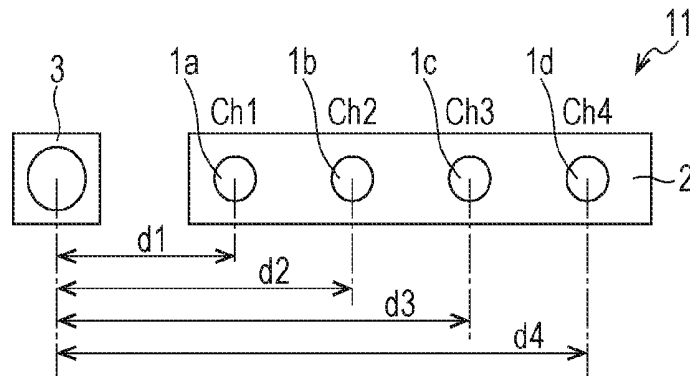

FIG. 10

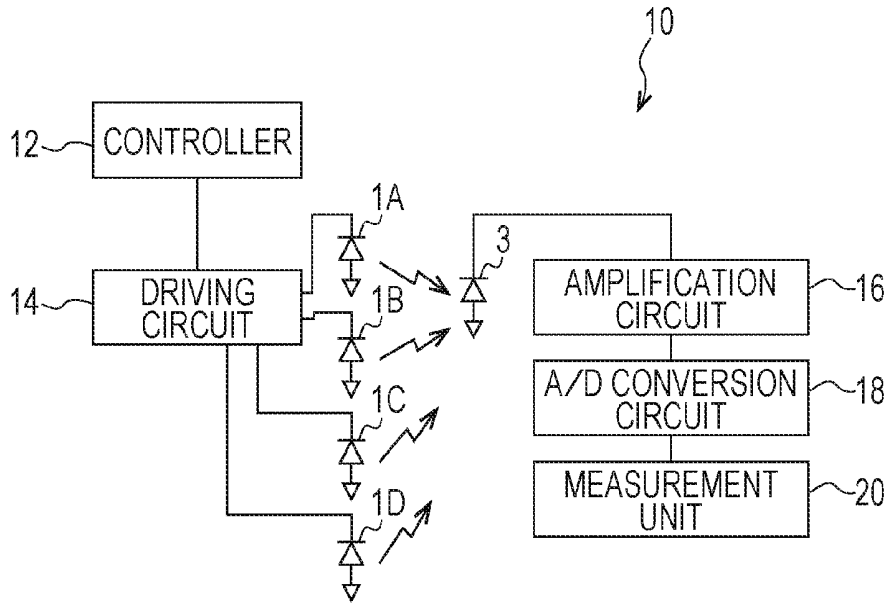

FIG. 11

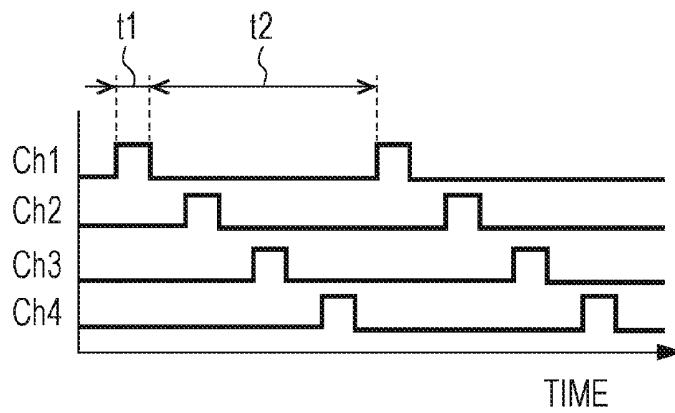

FIG. 12

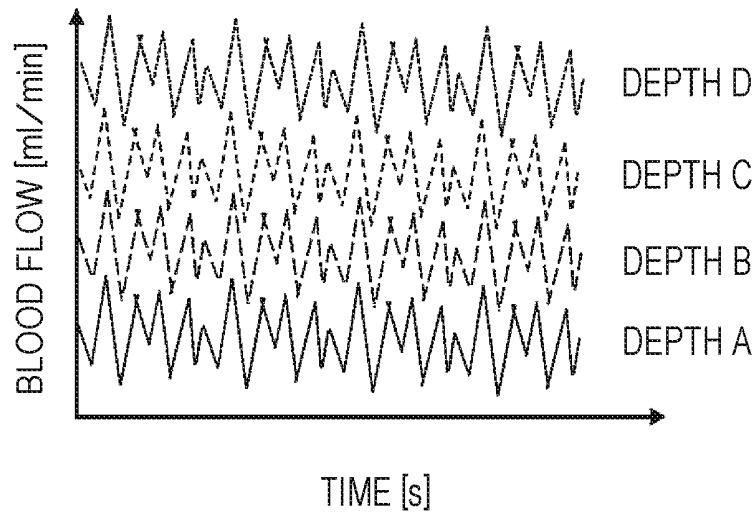

FIG. 13

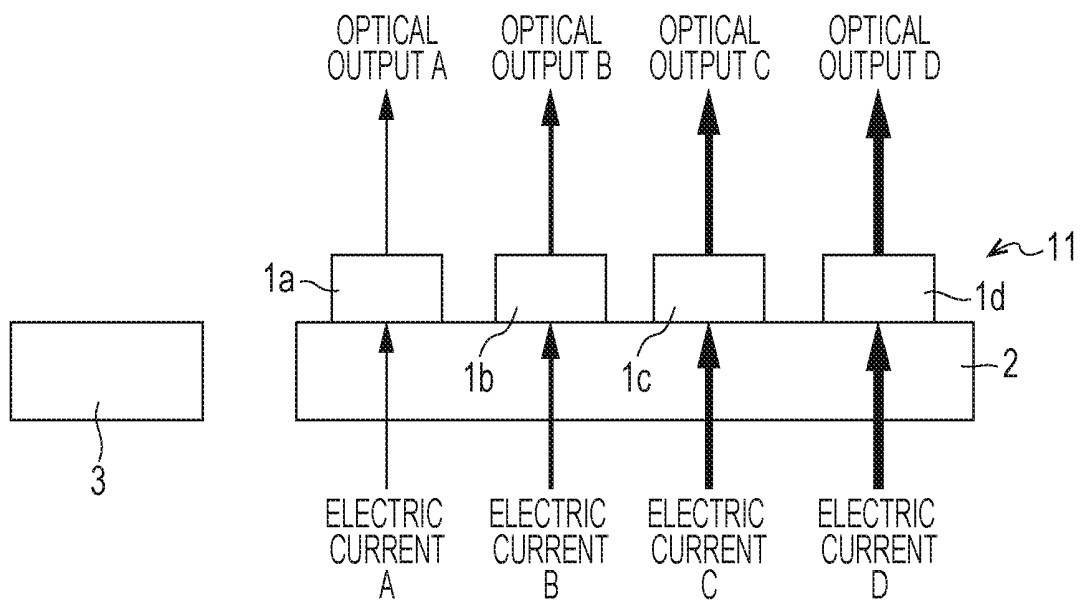

FIG. 14

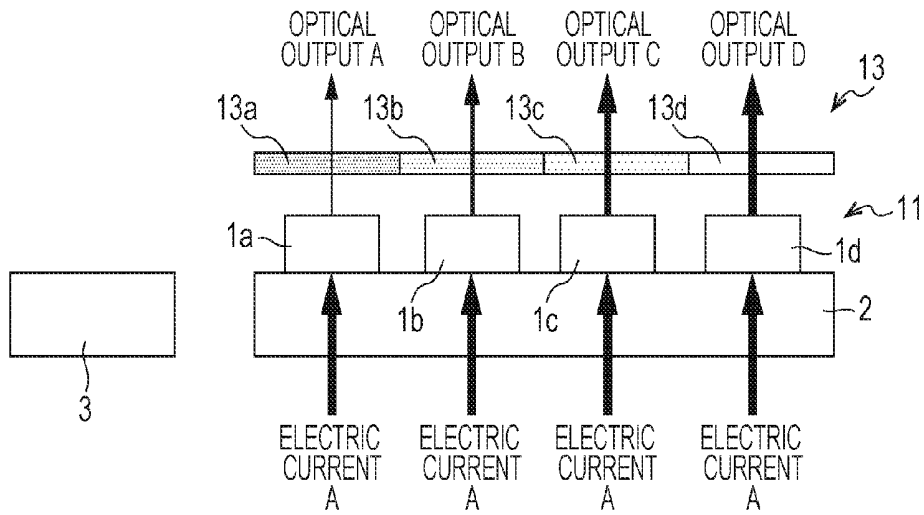

FIG. 15

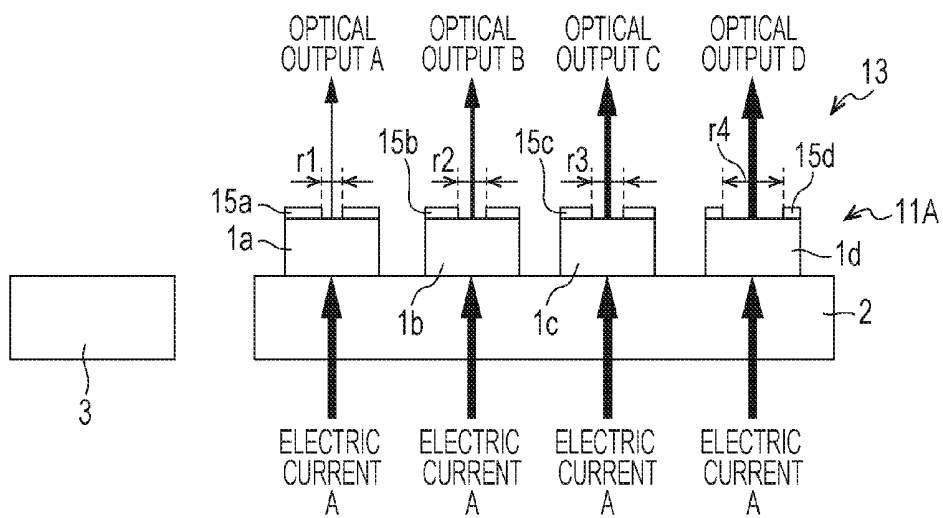

FIG. 16

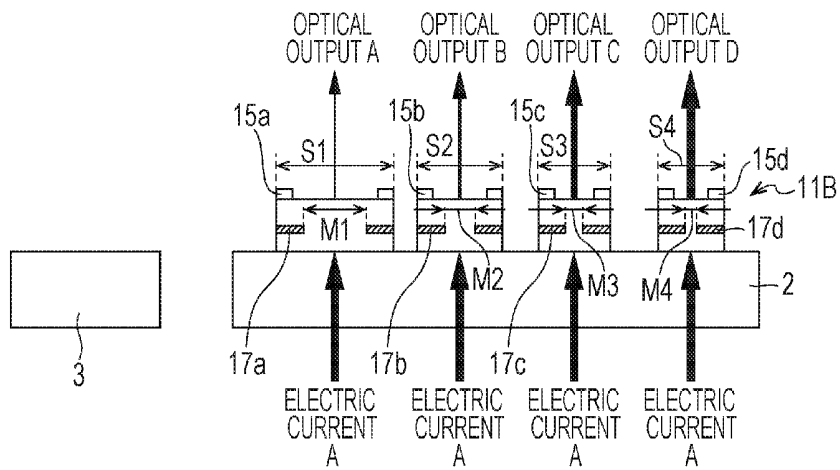
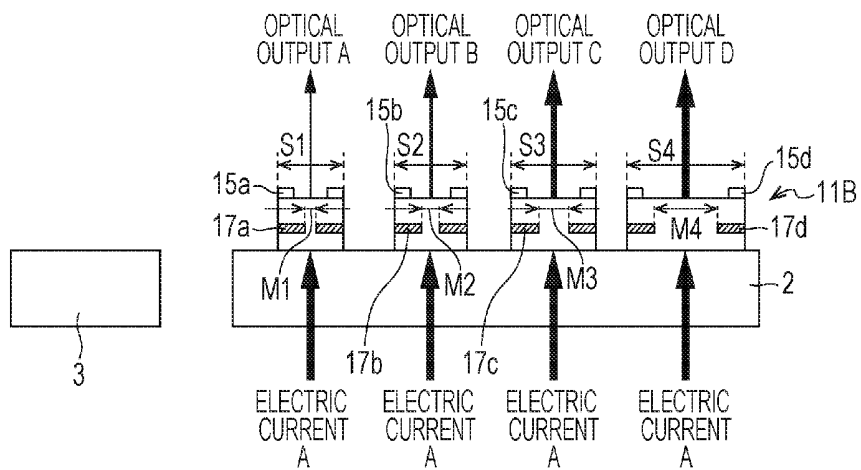

FIG. 17



## LIVING-BODY INFORMATION MEASURING DEVICE

### CROSS-REFERENCE TO RELATED APPLICATIONS

[0001] This application is based on and claims priority under 35 USC 119 from Japanese Patent Application No. 2016-064461 filed Mar. 28, 2016.

### BACKGROUND

[0002] (i) Technical Field

[0003] The present invention relates to a living-body information measuring device.

[0004] (ii) Related Art

[0005] Some blood flow sensors, which are examples of living body sensors, measure the blood flow, the amount of a blood component, or the like of a subcutaneous blood vessel, such as a capillary vessel, by emitting a laser beam toward a living body and by receiving a reflected light beam reflected from the living body. It is known that the depth, beneath a skin, of a region that a blood flow sensor measures depends on the distance between a light-emitting element and a light-receiving element. To be specific, it is known that the depth, beneath a skin, of a region that a blood flow sensor measures increases as the distance between the light-emitting element and the light-receiving element increases. In order to increase the amount of information necessary for diagnosis and health care, it is preferable to obtain living-body information at more than one depth.

### SUMMARY

[0006] According to an aspect of the invention, a living-body information measuring device includes plural light-emitting elements; a light-receiving element that is disposed at a position at different distances from the light-emitting elements and that receives reflected light beams that are reflected from a living body when the light-emitting elements emit light beams toward the living body; a control unit that controls the light-emitting elements so that the light-emitting elements successively emit the light beams; and a measurement unit that measures living-body information at plural depths in the living body by using the reflected light beams that are successively received by the light-receiving element.

### BRIEF DESCRIPTION OF THE DRAWINGS

[0007] Exemplary embodiments of the present invention will be described in detail based on the following figures, wherein:

[0008] FIG. 1 is a schematic view illustrating an example of measurement of a blood flow;

[0009] FIG. 2 is a graph illustrating one example of a change in an amount of received light due to reflected light from a living body;

[0010] FIG. 3 is a schematic diagram used to explain a Doppler shift that occurs when a blood vessel is irradiated with a laser beam;

[0011] FIG. 4 is a schematic diagram used to explain speckles that occur when a blood vessel is irradiated with a laser beam;

[0012] FIG. 5 is a graph illustrating one example of a spectrum distribution with respect to change in an amount of received light;

[0013] FIG. 6 is a graph illustrating one example of a change in the blood flow;

[0014] FIG. 7 is a plan view illustrating plural light-emitting elements and a light-receiving element according to a first exemplary embodiment;

[0015] FIG. 8 illustrates a living-body information measuring device on which a fingertip is placed;

[0016] FIG. 9 is a plan view of a surface-emitting laser array;

[0017] FIG. 10 is an exemplary block diagram of the living-body information measuring device;

[0018] FIG. 11 is a timing chart of light-emission timings;

[0019] FIG. 12 is a graph representing blood flows at plural depths;

[0020] FIG. 13 is a side view of a surface-emitting laser array according to a second exemplary embodiment;

[0021] FIG. 14 is a side view of a surface-emitting laser array according to a third exemplary embodiment;

[0022] FIG. 15 is a side view of a surface-emitting laser array according to a fourth exemplary embodiment;

[0023] FIG. 16 is a side view of a surface-emitting laser array according to a fifth exemplary embodiment; and

[0024] FIG. 17 is a side view of a surface-emitting laser array according to a modification of the fifth exemplary embodiment.

### DETAILED DESCRIPTION

[0025] Hereinafter, exemplary embodiments of the present invention will be described with reference to the drawings. In all of the drawings, elements that perform the same operations or have the same functions will be denoted by the same numerals, and redundant descriptions of such elements will be omitted.

#### First Exemplary Embodiment

[0026] Referring to FIG. 1, a method of measuring blood flow information, which is an example of living-body information related to blood, will be described.

[0027] As illustrated in FIG. 1, blood flow information is measured by emitting light from a light-emitting element 1 toward a patient's body (living body 8); receiving light that is reflected or transmitted by an artery 4, a vein 5, a capillary vessel 6, or the like in the patient's body by using a light-receiving element 3; and by measuring the intensity of the received light, that is, the amount of reflected light or transmitted light received by the light-receiving element 3.

#### Measurement of Blood Flow Information

[0028] FIG. 2 illustrates graphs showing a curve 80 that represents an example the amount of reflected light received by the light-receiving element 3. In the graph of FIG. 2, the horizontal axis represents the time and the vertical axis represents the output of the light-receiving element 3, that is, the amount of light received by the light-receiving element 3.

[0029] As illustrated in FIG. 2, the amount of light received by the light-receiving element 3 changes with time. It is considered that this change occurs due to the following first to third optical phenomena that occur when the living body 8, including blood vessels, is irradiated with light.

[0030] The first optical phenomenon is a change in absorption of light that occurs due to a change in the volume of blood existing in a blood vessel that is being measured by

pulsation. The blood includes blood cells, such as red blood cells, and the blood moves in a blood vessel, such as the capillary vessel 6. Therefore, when the blood volume changes, the number of blood cells that move in the blood vessel also changes. This change may influence the amount of light received by the light-receiving element 3.

[0031] The second optical phenomenon is an influence of a Doppler shift.

[0032] FIG. 3 illustrates a case where, for example, the light-emitting element 1 emits a coherent light beam 40, such as a laser beam, having a frequency  $\omega_0$  toward a region including the capillary vessel 6, which is an example of a blood vessel. In this case, a Doppler shift, having a frequency difference  $\Delta\omega_0$ , occurs in a part of a scattered light beam 42 that is generated due to scattering of the coherent light beam 40 by blood cells moving in the capillary vessel 6. The frequency difference  $\Delta\omega_0$  is determined by the moving speed of the blood cells. In contrast, another part of the scattered light beam 42 that is generated due to scattering of the coherent light beam 40 by an organ (stationary tissues) that does not include moving components, such as blood cells, has a frequency that is the same as the frequency  $\omega_0$  of the emitted light beam. Accordingly, the part of the scattered light 42 having a frequency  $(\omega_0 + \Delta\omega_0)$ , which is scattered by a blood vessel, such as the capillary vessel 6, and the other part of the scattered light 42 having the frequency  $\omega_0$ , which is scattered by a stationary tissues, interfere with each other. As a result, a beat signal having the frequency difference  $\Delta\omega_0$  is observed by the light-receiving element 3, and the amount of light received by the light-receiving element 3 changes with time. The frequency difference  $\Delta\omega_0$  of the beat signal observed by the light-receiving element 3, which depends on the moving speed of blood cells, is within a range having an upper limit of several tens of kilohertz.

[0033] The third optical phenomenon is an influence of speckles.

[0034] FIG. 4 illustrates a case where the light-emitting element 1 emits the coherent light beam 40, such as a laser beam, toward blood cells 7, such as red blood cells, that move in the direction of an arrow 44. In this case, the laser beam is scattered by the blood cells 7 in various directions. The scattered light, which have different phases, interfere with each other randomly. Thus, a light intensity distribution having a random spotted pattern occurs. A light intensity distribution pattern formed in this way is referred to as a "speckle pattern".

[0035] As described above, because the blood cells 7 move in the blood vessel, the way in which light is scattered by the blood cells 7 changes, and the speckle pattern varies with time. Accordingly, the amount of light received by the light-receiving element 3 changes with time.

[0036] Next, an example of a method of obtaining blood flow information will be described. Referring to FIG. 2, when the time-series data of the amount of light received by the light-receiving element 3 is obtained, a part of the data in a predetermined unit time  $T_0$  is cut out. By performing, for example, fast Fourier transform (FFT) on the data, a spectrum distribution for the frequency  $\omega$  is obtained. FIG. 5 is a graph showing a curve 82 representing an example of the spectrum distribution for the frequency  $\omega$  in the unit time  $T_0$ . In the graph of FIG. 5, the horizontal axis represents the frequency  $\omega$ , and the vertical axis represents the spectrum intensity.

[0037] The blood volume is proportional to a value obtained by normalizing, with respect to the total light amount, the area of power spectrum, which is represented by a hatched region 84 surrounded by the curve 82, the horizontal axis, and the vertical axis of the graph of FIG. 5. The blood velocity is proportional to the average frequency of the power spectrum represented by the curve 82. Therefore, the blood velocity is proportional to a value obtained by dividing the integral of the product of the frequency  $w$  and the power spectrum at the frequency  $\omega$  with respect to the frequency  $\omega$  by the area of the hatched region 84.

[0038] The blood flow, which is the product of the blood volume and the blood velocity, is obtained by using the aforementioned formulas for calculating the blood volume and the blood velocity. The blood flow, the blood velocity, and the blood volume are examples of blood flow information. However, blood flow information is not limited to these.

[0039] FIG. 6 is a graph showing a curve 86 representing an example of the calculated change in the blood flow per unit time  $T_0$ . In the graph of FIG. 6, the horizontal axis represents the time and the vertical axis represents the blood flow.

[0040] As illustrated in FIG. 6, the blood flow varies with time, and the trend of the variation is divided into two types. For example, a variation range 90 of the blood flow in an interval  $T_2$  of FIG. 6 is larger than a variation range 88 of the blood flow in an interval  $T_1$  of FIG. 6. Presumably this is because the change in the blood flow in the interval  $T_1$  is mainly due to pulsation and the change in the blood flow in the interval  $T_2$  is due to, for example, congestion.

[0041] As described above, it is known that the depth, beneath a skin, of a region that a blood flow sensor measures increases as the distance between the light-emitting element and the light-receiving element increases. In order to increase the amount of information necessary for diagnosis and health care, it is preferable to obtain living-body information at more than one depth.

[0042] Therefore, in the present exemplary embodiment, a light-receiving element is disposed at a position at different distances from plural light-emitting elements, and the light-emitting elements are controlled so that the light-emitting elements successively emit light beams. The blood flows at different depths in the living body are measured by using reflected light beams that are successively received by the light-receiving element.

[0043] FIG. 7 is a plan view illustrating an example of the arrangement of the plural light-emitting elements and the light-receiving element according to the present exemplary embodiment. FIG. 7 illustrates a case where four light-emitting elements 1A to 1D are used. The light-emitting elements 1A to 1D have the same characteristics. The number of light-emitting elements is not limited to four and may be appropriately determined in accordance with the number of depths at which living-body information is to be obtained. In the present exemplary embodiment, for example, surface-emitting lasers are used as the light-emitting elements 1A to 1D. Alternatively, edge-emitting lasers may be used. As described above, when measuring the blood flow, the spectrum distribution of light-receiving amount due to a beat signal is used. Therefore, preferably, laser devices that are capable of emitting light beams that easily generate beat signals are used as the light-emitting elements 1A to 1D.

[0044] As illustrated in FIG. 7, the light-emitting elements 1A to 1D and the light-receiving element 3 are arranged along a straight line. The distances  $d1$  to  $d4$  between the light-emitting elements 1A to 1D and the light-receiving element 3 differ from each other. To be specific,  $d1 < d2 < d3 < d4$ . Although the light-emitting elements 1A to 1D and the light-receiving element 3 are arranged along a straight line in FIG. 7, it is not necessary that the light-emitting elements 1A to 1D be arranged along a straight line, provided that the distances  $d1$  to  $d4$  between the light-emitting elements 1A to 1D and the light-receiving element 3 differ from each other.

[0045] As illustrated in FIG. 8, the light-emitting elements 1A to 1D and the light-receiving element 3 are arranged in a row in a housing 50. A transparent plate 52 is disposed so as to face the light-emitting surfaces of the light-emitting elements 1A to 1D. A user places his/her fingertip 54 on the transparent plate 52 and performs measurement. As illustrated in FIG. 8, the light-emitting element 1A emits a light beam 56A, the light-emitting element 1B emits a light beam 56B, the light-emitting element 1C emits a light beam 56C, and the light-emitting element 1D emits a light beam 56D. When the paths of the light beams 56A to 56D in the fingertip 54 are compared, the depth that each of the light beams 56A to 56D reaches increases as the distance from the light-receiving element 3 to a corresponding one of the light-emitting elements 1A to 1D increases.

[0046] As illustrated in FIG. 9, a surface-emitting laser array 11, in which plural light-emitting spots 1a to 1d are disposed on a single substrate 2, may be used.

[0047] FIG. 10 is an exemplary block diagram of a living-body information measuring device 10 according to the present exemplary embodiment.

[0048] As illustrated in FIG. 10, the living-body information measuring device 10 includes a controller 12, a driving circuit 14, an amplification circuit 16, an analog/digital (A/D) conversion circuit 18, a measurement unit 20, the light-emitting elements 1A to 1D, and the light-receiving element 3.

[0049] The driving circuit 14 includes a power supply circuit that supplies electric power to the light-emitting elements 1A to 1D. To the driving circuit 14, the controller 12 outputs a control signal for controlling the light-emission cycles and the light-emission periods of the light-emitting elements 1A to 1D.

[0050] When receiving the control signal from the controller 12, the driving circuit 14 supplies electric power to the light-emitting elements 1A to 1D to drive the light-emitting elements 1A to 1D in accordance with the light-emission cycles and the light-emission periods indicated by the control signal.

[0051] For example, as illustrated in FIG. 11, the driving circuit 14 repeatedly causes the light-emitting elements 1A (Ch1), 1B (Ch2), 1C (Ch3), and 1D (Ch4) to successively emit light beams each for a period  $t1$  and to stop emitting a light beam for a period  $t2$  while shifting the time at which the light-emitting elements 1A to 1D emit light beams.

[0052] The amplification circuit 16 amplifies a voltage, which corresponds to the intensity of light received by the light-receiving element, to a level within a specified input voltage range of the A/D conversion circuit 18. Here, for example, the light-receiving element 3 outputs a voltage corresponding to the intensity of received light. Alternatively, the light-receiving element 3 may output an electric

current corresponding to the intensity of received light. In this case, the amplification circuit 16 amplifies the electric current, output from the light-receiving element 3, to a level within a specified input current range of the A/D conversion circuit 18.

[0053] The voltage amplified by the amplification circuit 16 is input to the A/D conversion circuit 18. The A/D conversion circuit 18 digitizes the amount of light received by the light-receiving element 3, which is represented by the voltage, and outputs the digitized amount of received light.

[0054] The amount of received light, which has been digitized by the A/D conversion circuit 18, is input to the measurement unit 20. The measurement unit 20 performs FFT on each of the amounts of light emitted from the light-emitting elements 1A to 1D and received by the light-receiving element 3 to calculate the spectrum distribution for the frequency  $\omega$ . Then, the measurement unit 20 measures the blood flow of the living body by integrating the spectrum distribution with respect to the entire frequency  $\omega$ . When the light-emitting elements 1A to 1D successively emit light beams at timings shown in FIG. 11, the amounts of the light beams emitted from the light-emitting elements 1A to 1D and received by the light-receiving element 3 are successively input to the measurement unit 20. The measurement unit 20 measures the blood flow by performing the aforementioned operation every time the amounts of received light are input. Thus, blood flows at plural depths are obtained as illustrated in FIG. 12.

[0055] As describe above, according to the present exemplary embodiment, the light-receiving element 3 is disposed at a position at different distances from the light-emitting elements 1A to 1D, and blood flows at plural depths of a living body are measured by using reflected light beams from the living body that are successively received by the light-receiving element 3. Therefore, blood flows at plural depths of the living body are obtained and living-body information useful for diagnosis and health care is obtained, in contrast to a case where a blood flow is obtained by emitting a light beam from a single light-emitting element and receiving a reflected light beam from the living body.

#### Second Exemplary Embodiment

[0056] Next, a second exemplary embodiment of the present invention will be described.

[0057] FIG. 13 is a side view of the surface-emitting laser array 11 according to the present exemplary embodiment. As described above, the surface-emitting laser array 11 includes plural luminous points 1a to 1d on the single substrate 2. Descriptions of the other components of the second exemplary embodiment, which are the same as those of the first exemplary embodiment, will be omitted.

[0058] In the present exemplary embodiment, the luminous points 1a to 1d are controlled so that a driving current for driving each luminous point decreases as the distance from the light-receiving element 3 to the luminous point decreases and the electric current for driving each luminous point increases as the distance from the light-receiving element 3 to the luminous point increases.

[0059] As illustrated in FIG. 13, the driving circuit 14 supplies electric currents A to D, for driving the luminous points 1a to 1d, to the luminous points 1a to 1d. The electric current A supplied to the luminous point 1a, which is at the shortest distance from the light-receiving element 3, is the smallest. The electric current D supplied to the luminous

point  $1d$ , which is at the longest distance from the light-receiving element  $3$ , is the largest.

[0060] Thus, among optical outputs A to D from the luminous points  $1a$  to  $1d$ , the optical output A from the luminous point  $1a$ , which is at the shortest distance from the light-receiving element  $3$ , is the smallest; and the optical output D from the luminous point  $1d$ , which is at the longest distance from the light-receiving element  $3$ , is the largest. As the distance from the light-receiving element  $3$  to the luminous point increases, the distance that light propagates in the living body increases and the attenuation of the light increases. Therefore, by increasing the electric current supplied to each luminous point with increasing distance from the light-receiving element  $3$ , variation in the amount of light emitted from the luminous points  $1a$  to  $1d$  and received by the light-receiving element  $3$  is suppressed.

[0061] Preferably, the values of the electric currents supplied to the luminous points  $1a$  to  $1d$  are set so that the amount of light emitted from each of the luminous points  $1a$  to  $1d$  and received by the light-receiving element  $3$  is within the dynamic range of the light-receiving element  $3$ . In this case, living-body information at plural depths is obtained with high precision.

[0062] The magnitudes of the electric currents A to D may be changed in accordance with the type of living-body information to be measured. In this case, optical outputs suitable for the type of the measured living-body information are realized.

#### Third Exemplary Embodiment

[0063] Next, a third exemplary embodiment of the present invention will be described.

[0064] In the present exemplary embodiment, as illustrated in FIG. 14, an attenuating filter  $13$  is disposed on the optical output side of the surface-emitting laser array  $11$ . Descriptions of the other components of the third exemplary embodiment, which are the same as those of the second exemplary embodiment, will be omitted.

[0065] The attenuating filter  $13$  attenuates light beams emitted from the luminous points  $1a$  to  $1d$  so that the attenuation ratio of a light beam emitted from each luminous point increases as the distance from the light-receiving element  $3$  to the luminous point decreases and the attenuation ratio of the light beam emitted from each luminous point decreases as the distance from the luminous point  $3$  to the luminous point increases. To be specific, the attenuating filter  $13$  includes a region  $13a$ , through which a light beam emitted from the luminous point  $1a$  passes; a region  $13b$ , through which a light beam emitted from the luminous point  $1b$  passes; a region  $13c$ , through which a light beam emitted from the luminous point  $1c$  passes; and a region  $13d$ , through which a light beam emitted from the luminous point  $1d$  passes. The attenuation ratios in the regions  $13a$ ,  $13b$ ,  $13c$ , and  $13d$  decrease in this order.

[0066] The driving circuit  $14$  supplies the same electric current A to the luminous points  $1a$  to  $1d$ . Thus, among the optical outputs A to D from the luminous points  $1a$  to  $1d$ , the optical output A from the luminous point  $1a$ , which is at the shortest distance from the light-receiving element  $3$ , is the smallest; and the optical output D from the luminous point  $1d$ , which is at the longest distance from the light-receiving element  $3$ , is the largest. As the distance from the light-receiving element  $3$  to the luminous point increases, the distance that light propagates in the living body increases

and the attenuation of the light increases. Therefore, by disposing the attenuating filter  $13$ , in which the attenuation ratio of light decreases with increasing distance from the light-receiving element  $3$ , on the optical output side of the surface-emitting laser array  $11$ , variation in the amount of light emitted from the luminous points  $1a$  to  $1d$  and received by the light-receiving element  $3$  is suppressed.

[0067] Preferably, the attenuation ratios of the regions of the attenuating filter  $13$  are set so that the amount of light emitted from each of the luminous points  $1a$  to  $1d$  and received by the light-receiving element  $3$  is within the dynamic range of the light-receiving element  $3$ . In this case, living-body information at plural depths is obtained with high precision.

#### Fourth Exemplary Embodiment

[0068] Next, a fourth exemplary embodiment of the present invention will be described.

[0069] FIG. 15 illustrates a surface-emitting laser array  $11A$  according to the present exemplary embodiment. Descriptions of the other components of the fourth exemplary embodiment, which are the same as those of the second exemplary embodiment, will be omitted.

[0070] As illustrated in FIG. 15, the luminous points  $1a$  to  $1d$  respectively include upper electrodes  $15a$  to  $15d$ . In the surface-emitting laser array  $11A$ , the area of an opening in the upper electrode of each luminous point decreases as the distance from the light-receiving element  $3$  to the luminous point decreases, and the area of the opening in the upper electrode of each luminous point increases as the distance from the light-receiving element  $3$  to the luminous point increases. In the present exemplary embodiment, the luminous points  $1a$  to  $1d$  each have a circular shape in plan view as illustrated in FIG. 9. Likewise, the upper electrodes  $15a$  to  $15d$  and the openings of the upper electrodes  $15a$  to  $15d$  each have a circular shape in plan view. Accordingly, the diameter of the opening in the upper electrode of each luminous point of the light-receiving element  $3$  decreases as the distance from the light-receiving element  $3$  to the luminous point decreases, and the diameter of the opening in the upper electrode of the luminous point of the light-receiving element  $3$  increases as the distance from the light-receiving element  $3$  to the luminous point increases.

[0071] That is, as illustrated in FIG. 15, the diameter  $r1$  of the opening in the upper electrode  $15a$  of the luminous point  $1a$ , which is at the shortest distance from the light-receiving element  $3$ , is the smallest; and the diameter  $r4$  of the opening in the upper electrode  $15d$  of the luminous point  $1d$ , which is at the longest distance from the light-receiving element  $3$ , is the largest.

[0072] The driving circuit  $14$  supplies the same electric current A to the luminous points  $1a$  to  $1d$ . Thus, among the optical outputs A to D from the luminous points  $1a$  to  $1d$ , the optical output A from the luminous point  $1a$ , which is at the shortest distance from the light-receiving element  $3$ , is the smallest, and the optical output D from the luminous point  $1d$ , which is at the longest distance from the light-receiving element  $3$ , is the largest. As the distance from the light-receiving element  $3$  to each luminous point increases, the distance that light propagates in the living body increases and the attenuation of the light increases. Therefore, by increasing the diameter of the opening in the upper electrode with increasing distance from the light-receiving element  $3$ ,

variation in the amount of light emitted from the luminous points **1a** to **1d** and received by the light-receiving element **3** is suppressed.

**[0073]** Preferably, the areas of the openings (the diameters of the openings) in the upper electrodes are set so that the amount of light emitted from each of the luminous points **1a** to **1d** and received by the light-receiving element **3** is within the dynamic range of the light-receiving element **3**. In this case, living-body information at plural depths is obtained with high precision.

#### Fifth Exemplary Embodiment

**[0074]** Next, a fifth exemplary embodiment of the present invention will be described.

**[0075]** FIG. 16 illustrates a surface-emitting laser array **11B** according to the present exemplary embodiment. Descriptions of the other components of the fifth exemplary embodiment, which are the same as those of the second exemplary embodiment, will be omitted.

**[0076]** The luminous points **1a** to **1d** of the surface-emitting laser array **11B** according to the present exemplary embodiment each have a circular shape in plan view. Oxidized regions **17a** to **17d** each have an annular shape that surrounds a non-oxidized region in plan view. The diameter of each luminous point increases as the distance from the light-receiving element **3** to the luminous point decreases, and the diameter of each luminous point decreases as the distance from the light-receiving element **3** to the luminous point increases. That is, as illustrated in FIG. 16, the diameter **S1** of the luminous point **1a**, which is at the shortest distance from the light-receiving element **3**, is the largest; and the diameter **S4** of the luminous point **1d**, which is at the longest distance from the light-receiving element **3**, is the smallest.

**[0077]** Oxidization times required to form the oxidized regions **17a** to **17d** of the luminous points **1a** to **1d** are the same for all the luminous points **1a** to **1d**. Therefore, oxidation distances of the oxidized regions **17a** to **17d** are substantially the same. Accordingly, as the diameters of the luminous points **1a** to **1d** differ from each other, the diameters of the non-oxidized regions surrounded by the oxidized regions **17a** to **17d**, that is, the mesa sizes differ from each other.

**[0078]** That is, as illustrated in FIG. 16, the mesa size **M1** of the luminous point **1a**, which is at the shortest distance from the light-receiving element **3**, is the largest; and the mesa size **M4** of the luminous point **1d**, which is at the longest distance from the light-receiving element **3**, is the smallest.

**[0079]** The driving circuit **14** supplies the same electric current **A** to the luminous points **1a** to **1d**. Thus, among the optical outputs **A** to **D** from the luminous points **1a** to **1d**, the optical output **A** from the luminous point **1a**, which is at the shortest distance from the light-receiving element **3**, is the smallest, and the optical output **D** from the luminous point **1d**, which is at the longest distance from the light-receiving element **3**, is the largest. As the distance from the light-receiving element **3** to the luminous point increases, the distance that light propagates in the living body increases and the attenuation of the light increases. Therefore, by increasing the mesa size with increasing distance from the light-receiving element **3**, variation in the amount of light emitted from the luminous points **1a** to **1d** and received by the light-receiving element **3** is suppressed.

**[0080]** Typically, the light-emitting amount decreases as the mesa size increases. However, when the driving electric current is increased, the light-emitting amount may increase as the mesa size increases. Therefore, as illustrated in FIG. 17, depending on the driving conditions, the relationship among the mesa sizes of the luminous points may become opposite to the aforementioned relationship. Preferably, the mesa sizes (the diameters of the non-oxidized regions) of the luminous points are set so that the amount of light emitted from each of the luminous points **1a** to **1d** and received by the light-receiving element **3** is within the dynamic range of the light-receiving element **3**. In this case, living-body information at plural depths is obtained with high precision.

**[0081]** In each of the exemplary embodiments described above, the living-body information measuring device **10** is used to measure the blood flow as living-body information. However, as described above, the living-body information measuring device **10** may be used to measure the blood velocity, instead of the blood flow. The pulse rate is measured by using the amount of light received by the light-receiving element **3**, because the amount of light received by the light-receiving element **3** changes due to pulsation of an artery. The photoplethysmogram is measured by calculating the second derivative of a waveform obtained by measuring the change in the pulse rate in chronological order. The photoplethysmogram is used, for example, to estimate a vascular age or to diagnose arteriosclerosis. The living-body information measuring device **10** may be used to measure a blood component (blood sugar level or the like), the blood pressure, and the like.

**[0082]** The foregoing description of the exemplary embodiments of the present invention has been provided for the purposes of illustration and description. It is not intended to be exhaustive or to limit the invention to the precise forms disclosed. Obviously, many modifications and variations will be apparent to practitioners skilled in the art. The embodiments were chosen and described in order to best explain the principles of the invention and its practical applications, thereby enabling others skilled in the art to understand the invention for various embodiments and with the various modifications as are suited to the particular use contemplated. It is intended that the scope of the invention be defined by the following claims and their equivalents.

What is claimed is:

1. A living-body information measuring device comprising:

- a plurality of light-emitting elements;
- a light-receiving element that is disposed at a position at different distances from the light-emitting elements and that receives reflected light beams that are reflected from a living body when the light-emitting elements emit light beams toward the living body;
- a control unit that controls the light-emitting elements so that the light-emitting elements successively emit the light beams; and
- a measurement unit that measures living-body information at a plurality of depths in the living body by using the reflected light beams that are successively received by the light-receiving element.

2. The living-body information measuring device according to claim 1,

wherein the control unit controls the plurality of light-emitting elements so that an electric current for driving each light-emitting element decreases as the distance

from the light-receiving element to the light-emitting element decreases and the electric current for driving each light-emitting element increases as the distance from the light-receiving element to the light-emitting element increases.

3. The living-body information measuring device according to claim 1, further comprising:

an attenuating filter that attenuates the light beams emitted from the plurality of light-emitting elements so that an attenuation ratio of the light beam emitted from each light-emitting element increases as the distance from the light-receiving element to the light-emitting element decreases and the attenuation ratio of the light beam emitted from each light-emitting element decreases as the distance from the light-receiving element to the light-emitting element increases.

4. The living-body information measuring device according to claim 1,

wherein an area of an opening in an upper electrode of each light-emitting element decreases as the distance from the light-receiving element to the light-emitting element decreases and the area of the opening in the upper electrode of each light-emitting element increases as the distance from the light-receiving element to the light-emitting element increases.

5. The living-body information measuring device according to claim 1,

wherein a mesa size of each light-emitting element increases as the distance from the light-receiving element to the light-emitting element decreases and the mesa size of each light-emitting element decreases as the distance from the light-receiving element to the light-emitting element increases.

6. The living-body information measuring device according to claim 1,

wherein a mesa size of each light-emitting element decreases as the distance from the light-receiving element to the light-emitting element decreases and the mesa size of each light-emitting element increases as the distance from the light-receiving element to the light-emitting element increases.

7. The living-body information measuring device according to claim 1,

wherein the plurality of light-emitting elements are a plurality of surface-emitting lasers or are a plurality of light-emitting spots disposed on a single substrate of a surface-emitting laser array.

8. The living-body information measuring device according to claim 1,

wherein the living-body information includes at least one of a blood flow, a blood velocity, a blood volume, a pulse rate, a photoplethysmogram, a blood component, and a blood pressure of the living body.

\* \* \* \* \*

专利名称(译)	生物体信息测量装置		
公开(公告)号	<a href="#">US20170273576A1</a>	公开(公告)日	2017-09-28
申请号	US15/229206	申请日	2016-08-05
[标]申请(专利权)人(译)	富士施乐株式会社		
申请(专利权)人(译)	富士施乐CO., LTD.		
当前申请(专利权)人(译)	富士施乐CO., LTD.		
[标]发明人	OZAWA HIDEAKI UMEKAWA HIDEYUKI KOJIMA TOMOAKI SAKAI KAZUHIRO AKAMATSU MANABU		
发明人	OZAWA, HIDEAKI UMEKAWA, HIDEYUKI KOJIMA, TOMOAKI SAKAI, KAZUHIRO AKAMATSU, MANABU		
IPC分类号	A61B5/026 A61B5/1455 A61B5/0205 A61B5/00		
CPC分类号	A61B5/0261 A61B5/7278 A61B5/1455 A61B5/0205 A61B5/021 A61B5/7225 A61B2562/0233 A61B5/02416 A61B5/7257 A61B5/0075 A61B5/02007 A61B5/02427 A61B5/0285 A61B5/14532 A61B5/6826 A61B2560/0204 A61B2562/043		
优先权	2016064461 2016-03-28 JP		
其他公开文献	US10271747		
外部链接	<a href="#">Espacenet</a> <a href="#">USPTO</a>		

摘要(译)

一种生物体信息测量装置，包括多个发光元件，光接收元件，所述光接收元件设置在距所述发光元件不同距离的位置处，并且接收当所述光从所述生物体反射的反射光束时 - 发光元件向生物体发射光束，控制发光元件使得发光元件连续发射光束的控制单元，以及测量生活中多个深度的生物体信息的测量单元通过使用由光接收元件连续接收的反射光束。

